

---

# **GOLDILOCKS 21c.1 User Manual (en)**

**SUNJESOFT Inc.**

Copyright [2019-2025] SUNJESOFT Inc. Licensed under the Apache License, Version 2.0 (the "License");

you may not use this file except in compliance with the License.

You may obtain a copy of the License at <http://www.apache.org/licenses/LICENSE-2.0>

Unless required by applicable law or agreed to in writing,

software distributed under the License is distributed on an "AS IS" BASIS, WITHOUT WARRANTIES OR CONDITIONS OF ANY KIND, either express or implied. See the License for the specific language governing permissions and limitations under the License.

# Table of Contents

---

Table of Contents .....	iii
<b>Part I. Getting Started .....</b>	<b>1</b>
<b>1. Preface .....</b>	<b>5</b>
1.1 Overview .....	6
1.2 Summary .....	7
1.3 Characteristics of GOLDILOCKS Cluster .....	11
<b>2. Tutorial .....</b>	<b>15</b>
2.1 Managing GOLDILOCKS Instance .....	16
2.2 Installing GOLDILOCKS and Creating Database .....	22
2.3 Managing Database Memory Structure .....	40
2.4 Managing Schema Object .....	48
2.5 Managing User .....	51
2.6 GOLDILOCKS Property .....	55
2.7 GOLDILOCKS Utility .....	57
<b>3. Cluster Tutorial .....</b>	<b>61</b>
3.1 Managing GOLDILOCKS Cluster System .....	62
3.2 Installing GOLDILOCKS and Creating Database .....	70
3.3 Managing Schema Object .....	74
3.4 GOLDILOCKS Property .....	85
<b>4. What's New .....</b>	<b>89</b>
4.1 Feature Matrix .....	90
4.2 What's New in GOLDILOCKS 21c.1 .....	156
4.3 Patch Notes .....	165
<b>Part II. Administration Manual .....</b>	<b>281</b>
<b>5. Basic Management of GOLDILOCKS Database .....</b>	<b>307</b>

5.1	Creating and Configuring GOLDILOCKS Database	308
5.2	Starting up and Shutting down GOLDILOCKS Instance	311
5.3	Managing Process	318
5.4	Managing Memory	325
5.5	Monitoring	327
<b>6.</b>	<b>Structure and Storage Structure of GOLDILOCKS Database</b>	<b>341</b>
6.1	Managing Control File	342
6.2	Managing Redo Log File	346
6.3	Managing Archive Redo Log File	350
6.4	Managing Tablespace	352
6.5	Managing Data File	358
6.6	Buffer Cache	360
<b>7.</b>	<b>Backup and Recovery of GOLDILOCKS Database</b>	<b>363</b>
7.1	ARCHIVELOG Mode	364
7.2	Backup and Recovery	366
<b>8.</b>	<b>GOLDILOCKS Database Replication</b>	<b>387</b>
8.1	Overview	388
8.2	Operating Method	389
8.3	Trace Log	397
<b>9.</b>	<b>Database Information</b>	<b>401</b>
9.1	DICTIONARY_SCHEMA	402
9.2	INFORMATION_SCHEMA	608
9.3	PERFORMANCE_VIEW_SCHEMA	658
<b>10.</b>	<b>Server Property</b>	<b>729</b>
10.1	Server Property Information	730
10.2	AGING_INTERVAL	731
10.3	AGING_PLAN_INTERVAL	732
10.4	ARCHIVELOG_DIR_1 ~ ARCHIVELOG_DIR_10	733
10.5	ARCHIVELOG_FILE	734
10.6	ARCHIVELOG_MODE	735
10.7	BACKUP_DIR_1 ~ BACKUP_DIR_10	736
10.8	BLOCK_READ_COUNT	737
10.9	BROADCAST_INDEX_REBUILD_PROTOCOL	738
10.10	BROADCAST_REBALANCE_PROTOCOL	739
10.11	BUFFER_CACHE_SIZE	740
10.12	BUFFER_CHECKPOINT_LIST_COUNT	741
10.13	BUFFER_FLUSH_THREADS	742
10.14	BUFFER_FLUSHING_INTERVAL	743

10.15	BUFFER_FREE_LIST_COUNT	744
10.16	BUFFER_HASH_BUCKETS	745
10.17	BUFFER_HOT_REGION_CRITERIA	746
10.18	BUFFER_HOT_REGION_PERCENT	747
10.19	BUFFER_LRU_LIST_COUNT	748
10.20	BUFFER_MULTIPAGE_READ_COUNT	749
10.21	BUFFER_PREFETCH_PAGE_COUNT	750
10.22	BULK_IO_PAGE_COUNT	751
10.23	CDISPATCHER_HOT_POLICY_INTERVAL	752
10.24	CDISPATCHER_LOCKLESS_THREADS	753
10.25	CDISPATCHER_SOCKET_BUFFER_SIZE	754
10.26	CDISPATCHER_SYNC_THREADS	755
10.27	CDISPATCHER_THREADS	756
10.28	CHANGE_TRACKING	757
10.29	CHANGE_TRACKING_EXTENT_SIZE	758
10.30	CHANGE_TRACKING_FILE	759
10.31	CHAR_LENGTH_UNITS	760
10.32	CHARACTER_SET	762
10.33	CHECK_DEDICATE_CONNECTION_INTERVAL	763
10.34	CLIENT_MAX_COUNT	764
10.35	CLIENT_NUMA_POLICY	765
10.36	CLOSE_PSM_CHILD_STMTS	766
10.37	CLUSTER_ASYNC_COMMIT	767
10.38	CLUSTER_ASYNC_REPLICATION	768
10.39	CLUSTER_CM_BUFFER_COUNT	769
10.40	CLUSTER_CM_BUFFER_SIZE	770
10.41	CLUSTER_CM_READ_BUFFER_SIZE	771
10.42	CLUSTER_COMMIT_SLAVES	772
10.43	CLUSTER_COMMIT_STREAM_ISOLATION	773
10.44	CLUSTER_CONNECTION	774
10.45	CLUSTER_CONNECTION_TIMEOUT_SEC	775
10.46	CLUSTER_DATA_SYNC_SERVERS	776
10.47	CLUSTER_DEADLOCK_TIMEOUT	777
10.48	CLUSTER_DISPATCHER_IN_QUEUE_SIZE	778
10.49	CLUSTER_DISPATCHER_NUMA_STREAM_MAP	779
10.50	CLUSTER_DISPATCHER_OUT_QUEUE_SIZE	780
10.51	CLUSTER_HEARTBEAT_INTERVAL	781
10.52	CLUSTER_HEARTBEAT_RETRY_COUNT	782
10.53	CLUSTER_IGNORE_INACTIVE_MEMBER	783

10.54	CLUSTER_MAX_PACKET_SIZE	784
10.55	CLUSTER_MAX_PAYLOAD_SIZE	785
10.56	CLUSTER_PACKET_ALLOCATION_TIMEOUT	786
10.57	CLUSTER_PROTOCOL_FAILOVER_POLICY_TIMEOUT	787
10.58	CLUSTER_PROTOCOL_SESSION_FATAL_POLICY_TIMEOUT	788
10.59	CLUSTER_SERVER_RESPONSE_QUEUE_SIZE	789
10.60	CLUSTER_SESSION_HASH_BUCKETS	790
10.61	CLUSTER_SPLIT_BRAIN_RESOLUTION_POLICY	791
10.62	CLUSTER_SPLIT_BRAIN_RETRY_COUNT	792
10.63	COMMITTER_HOT_POLICY_INTERVAL	793
10.64	CONTROL_FILE_0 ~ CONTROL_FILE_7	794
10.65	CONTROL_FILE_COUNT	795
10.66	CONTROL_FILE_TEMP_NAME	796
10.67	COORDINATOR_COMMIT_WRITE_MODE	797
10.68	CSERVERS	798
10.69	DA_CLIENT_NUMA_NODE	799
10.70	DATA_STORE_MODE	800
10.71	DATABASE_ACCESS_MODE	801
10.72	DATABASE_INSTANCE_NAME	802
10.73	DDL_AUTOCOMMIT	803
10.74	DDL_LOCK_TIMEOUT	804
10.75	DEADLOCK_PRIORITY	805
10.76	DEFAULT_GLOBAL_SECONDARY_INDEX_CREATION	806
10.77	DEFAULT_INDEX_LOGGING	807
10.78	DEFAULT_INDEX_PCTFREE	808
10.79	DEFAULT_INITRANS	809
10.80	DEFAULT_MAXTRANS	810
10.81	DEFAULT_PCTFREE	811
10.82	DEFAULT_PCTUSED	812
10.83	DEFAULT_REMOVAL_BACKUP_FILE	813
10.84	DEFAULT_REMOVAL_OBSOLETE_BACKUP_LIST	814
10.85	DEFAULT_SHARDING	815
10.86	DISABLE_DDL	818
10.87	DISABLE_DDL_CDC_GIVEUP	822
10.88	DISABLE_SERIAL_DDL	823
10.89	DISABLE_UPDATE_PK_CDC_GIVEUP	828
10.90	DISALLOWED_PROTOCOL_TARGETTYPE	829
10.91	DISALLOWED_PROTOCOL_TARGETTYPE_WITH_ALL	830
10.92	DISALLOWED_PROTOCOL_TARGETTYPE_WITH_NAME	831

10.93	DISPATCHER_CM_BUFFER_SIZE	832
10.94	DISPATCHER_CM_UNIT_SIZE	833
10.95	DISPATCHER_CONNECTIONS	834
10.96	DISPATCHER_HOT_POLICY_INTERVAL	835
10.97	DISPATCHER_LOAD_BALANCING	836
10.98	DISPATCHER_NUMA_STREAM_MAP	837
10.99	DISPATCHER_QUEUE_SIZE	838
10.100	DISPATCHER_REQUEST_MINI_QUEUE_COUNT	839
10.101	DISPATCHER_RESPONSE_MINI_QUEUE_COUNT	840
10.102	DISPATCHERS	841
10.103	EXECUTE_INST_HASH_TABLE_USING_AVAILABLE_MEMORY	842
10.104	FETCH_FAILOVER	843
10.105	GLOBAL_CONNECTION_ALLOW_SESSION_DEPENDENCY	844
10.106	GLOBAL_JOURNAL_BUFFER_SIZE	845
10.107	GLOBAL_JOURNAL_BUFFER_TOTAL_MAX_SIZE	846
10.108	GLOBAL_PROPERTY_LOCK_TIMEOUT	847
10.109	GLOBAL_TRANSACTION_COMMIT_WRITE_MODE	848
10.110	GLOBAL_TRANSACTION_ISOLATION_SCOPE	849
10.111	GLOBAL_TRANSACTION_LOG_DIR	850
10.112	GLOBAL_TRANSACTION_LOG_FILE_SIZE	851
10.113	GMASTER_NUMA_NODE	852
10.114	GMON_AUTOSTART	853
10.115	HINT_ERROR	854
10.116	IDLE_TIMEOUT	855
10.117	IN_DOUBT_DECISION	856
10.118	IN_KEY_RANGE_ARRAY_COUNT	857
10.119	INCREMENTAL_BACKUP_SCAN_BUFFER_SIZE	858
10.120	INDEX_BUILD_PARALLEL_FACTOR	859
10.121	INDEX_LOGGING_THROTTLING	860
10.122	INDEX_REBUILD_BLOCK_READ_COUNT	861
10.123	INDEX_TREE_MERGE_PARALLEL_FACTOR	862
10.124	INST_ALLOCATOR_COUNT	863
10.125	INST_HASH_TABLE_BUCKET_MAX_COUNT	864
10.126	INST_TABLE_BLOCK_SIZE	865
10.127	IPC_CHANNEL_COUNT	866
10.128	JOURNAL_TEMP_DIR	867
10.129	KEEPALIVE_IDLE_TIME	868
10.130	LOCAL_CLUSTER_MEMBER	869
10.131	LOCAL_CLUSTER_MEMBER_HOST	870

10.132	LOCAL_CLUSTER_MEMBER_PORT	871
10.133	LOCAL_JOURNAL_BUFFER_SIZE	872
10.134	LOCATION_FILE	873
10.135	LOCATOR_QUERY_TIMEOUT	874
10.136	LOCK_HASH_TABLE_SIZE	875
10.137	LOCKLESS_CSERVICES	876
10.138	LOG_BLOCK_SIZE	877
10.139	LOG_BUFFER_SIZE	878
10.140	LOG_DIR	879
10.141	LOG_FILE_SIZE	880
10.142	LOG_GROUP_COUNT	881
10.143	LOG_MIRROR_MODE	882
10.144	LOG_MIRROR_SHARED_MEMORY_STATIC_SIZE	883
10.145	LOG_MIRROR_TIMEOUT	884
10.146	LOG_SYNC_INTERVAL	885
10.147	LOG_SYNC_INTERVAL_MSEC	886
10.148	MAX_GROUP_COUNT	887
10.149	MAX_JOURNAL_FILE_SIZE	888
10.150	MAX_NODE_COUNT	889
10.151	MAXIMUM_CONCURRENT_ACTIVITIES	890
10.152	MAXIMUM_FILE_CACHE_SIZE	891
10.153	MAXIMUM_FLANGE_COUNT	892
10.154	MAXIMUM_FLUSH_BUFFER_PAGE_COUNT	893
10.155	MAXIMUM_FLUSH_LOG_BLOCK_COUNT	894
10.156	MAXIMUM_FLUSH_PAGE_COUNT	895
10.157	MAXIMUM_INDEX_REBUILD_JOURNAL_REPLAY_COUNT	896
10.158	MAXIMUM_JOURNAL_REPLAY_COUNT	897
10.159	MAXIMUM_NAMED_CURSOR_COUNT	898
10.160	MAXIMUM_PACKAGE_INSTANCE_COUNT	900
10.161	MAXIMUM_SESSION_CM_BUFFER_SIZE	901
10.162	MEASURE_CLUSTER_LATENCY	902
10.163	MEMORY_MERGE_RUN_COUNT	903
10.164	MEMORY_SORT_RUN_SIZE	904
10.165	MIN_SAMPLE_ROW_COUNT	905
10.166	MINIMUM_UNDO_PAGE_COUNT	906
10.167	NET_BUFFER_SIZE	907
10.168	NLS_DATE_FORMAT	908
10.169	NLS_TIME_FORMAT	909
10.170	NLS_TIME_WITH_TIME_ZONE_FORMAT	910



10.171	NLS_TIMESTAMP_FORMAT	911
10.172	NLS_TIMESTAMP_WITH_TIME_ZONE_FORMAT	912
10.173	NUMA	913
10.174	NUMA_MAP	914
10.175	OFFLINE_MEMBER_AFTER_FAILOVER	915
10.176	ONLINE_INDEX_REBUILD_JOURNAL_REPLAY_THRESHOLD	916
10.177	ONLINE_JOURNAL_REPLAY_THRESHOLD	917
10.178	OS_GROUP_ACCESS	918
10.179	PACKET_COMPRESSION_THRESHOLD	919
10.180	PAGE_CHECKSUM_TYPE	920
10.181	PARALLEL_IO_FACTOR	921
10.182	PARALLEL_IO_GROUP_1 ~ PARALLEL_IO_GROUP_16	922
10.183	PARALLEL_LOAD_FACTOR	923
10.184	PENDING_LOG_BUFFER_COUNT	924
10.185	PLAN_CACHE	925
10.186	PLAN_CACHE_SIZE	926
10.187	PLAN_HISTORY	927
10.188	PLAN_HISTORY_SIZE	928
10.189	PRIVATE_STATIC_AREA_INIT_SIZE	929
10.190	PRIVATE_STATIC_AREA_NEXT_SIZE	930
10.191	PRIVATE_STATIC_AREA_SHRINK_THRESHOLD	931
10.192	PRIVATE_STATIC_AREA_SIZE	932
10.193	PROCESS_MAX_COUNT	933
10.194	QUERY_TIMEOUT	934
10.195	READABLE_ARCHIVELOG_DIR_COUNT	935
10.196	READABLE_BACKUP_DIR_COUNT	936
10.197	REBALANCE_BLOCK_READ_COUNT	937
10.198	RECOMPILE_CHECK_MINIMUM_PAGE_COUNT	938
10.199	RECOMPILE_PAGE_PERCENT	939
10.200	RECOVERY_LOG_BUFFER_SIZE	940
10.201	RECYCLEBIN	941
10.202	REDO_LOG_COMPRESSION_THRESHOLD	942
10.203	REFINE_RELATION	943
10.204	SESSION_FATAL_BEHAVIOR	944
10.205	SESSION_MEMORY_INIT_SIZE	945
10.206	SESSION_MEMORY_SHRINK_THRESHOLD	946
10.207	SHARED_MEMORY_ADDRESS	947
10.208	SHARED_MEMORY_STATIC_KEY	948
10.209	SHARED_MEMORY_STATIC_NAME	949

10.210	SHARED_MEMORY_STATIC_SIZE	950
10.211	SHARED_REQUEST_QUEUE_COUNT	951
10.212	SHARED_SERVERS	952
10.213	SHARED_SESSION	953
10.214	SNAPSHOT_STATEMENT_TIMEOUT	954
10.215	SQL_HISTORY_SIZE	955
10.216	SQL_HISTORY_TYPE	956
10.217	SUPPLEMENTAL_LOG_DATA_PRIMARY_KEY	957
10.218	SYSTEM_DISK_DATA_TABLESPACE_SIZE	958
10.219	SYSTEM_FILE_IO	959
10.220	SYSTEM_LOGGER_DIR	960
10.221	SYSTEM_MEMORY_AUX_TABLESPACE_SIZE	961
10.222	SYSTEM_MEMORY_DATA_TABLESPACE_SIZE	962
10.223	SYSTEM_MEMORY_DICT_TABLESPACE_SIZE	963
10.224	SYSTEM_MEMORY_TEMP_TABLESPACE_SIZE	964
10.225	SYSTEM_MEMORY_UNDO_TABLESPACE_SIZE	965
10.226	SYSTEM_TABLESPACE_DIR	966
10.227	SYSTEM_UDS_DIR	967
10.228	TCP_CLIENT_NUMA_NODE	968
10.229	TCP_NODELAY	969
10.230	TEMP_SEGMENT_CACHE_SIZE	970
10.231	TEMP_UNDO_ENABLED	971
10.232	TIMED_STATISTICS	972
10.233	TIMER_INTERVAL	973
10.234	TIMEZONE	974
10.235	TRACE_ALTER_SYSTEM	975
10.236	TRACE_DDL	976
10.237	TRACE_LOG_ID	977
10.238	TRACE_LOG_MSGBUF_SIZE	978
10.239	TRACE_LOG_TIME_DETAIL	979
10.240	TRACE_LOGGER	980
10.241	TRACE_LOGGER_REMOTE_HOST	981
10.242	TRACE_LOGGER_REMOTE_PORT	982
10.243	TRACE_LOGIN	983
10.244	TRACE_LONG_RUN_CURSOR	984
10.245	TRACE_LONG_RUN_SQL	986
10.246	TRACE_LONG_RUN_TIMER	988
10.247	TRACE_XA	989
10.248	TRANSACTION_ALLOCATION_TIMEOUT	990

10.249	TRANSACTION_COMMIT_WRITE_MODE	991
10.250	TRANSACTION_MAXIMUM_UNDO_PAGE_COUNT	992
10.251	TRANSACTION_TABLE_SIZE	993
10.252	TRANSACTION_TIMEOUT	995
10.253	UNDO_RELATION_ALLOCATION_TIMEOUT	996
10.254	UNDO_RELATION_COUNT	997
10.255	UNDO_SHRINK_THRESHOLD	999
10.256	USE_LARGE_PAGES	1,000
10.257	USER_DATA_TABLESPACE_MEDIA_TYPE	1,001
10.258	USER_DATA_TABLESPACE_SIZE	1,002
10.259	USER_DISK_DATA_TABLESPACE_NEXTSIZE	1,003
10.260	USER_TEMP_TABLESPACE_SIZE	1,004
10.261	XA_TRANSACTION_IDLE_TIMEOUT	1,005

**Part III. SQL Manual ..... 1,007**

<b>11.</b>	<b>SQL Elements</b>	<b>1,069</b>
11.1	Syntax Elements	1,070
11.2	Data Type	1,092
11.3	Format String	1,118
11.4	Expressions	1,132
11.5	Pseudo Columns	1,139
11.6	Operators	1,144
11.7	Functions	1,147
11.8	Conditions	1,155
<b>12.</b>	<b>SQL Languages</b>	<b>1,167</b>
12.1	Data Definition Language	1,168
12.2	Data Manipulation Language	1,178
12.3	Data Query Language	1,186
12.4	Control Language	1,209
12.5	Processing SQL in Cluster	1,214
<b>13.</b>	<b>SQL Objects</b>	<b>1,331</b>
13.1	Database	1,332
13.2	Profile	1,339
13.3	Audit Policy	1,345
13.4	Authorization	1,373
13.5	Schema	1,384
13.6	Tablespace	1,395
13.7	Table	1,398

13.8	Index	1,408
13.9	View	1,412
13.10	Sequence	1,415
13.11	Synonym	1,419
13.12	Stored Procedure	1,422
13.13	Stored Function	1,424
13.14	Package	1,426
<b>14.</b>	<b>Cluster Objects</b>	<b>1,429</b>
14.1	Cluster System	1,430
14.2	Cluster Group	1,437
14.3	Cluster Member	1,439
14.4	Cluster Location	1,441
14.5	Cluster Table and Shard	1,442
14.6	Global Secondary Index	1,461
<b>15.</b>	<b>SQL Tuning</b>	<b>1,463</b>
15.1	SQL Tuning	1,464
15.2	Rewriter	1,472
15.3	Enumerator	1,492
15.4	Cluster	1,527
15.5	Statistics Information	1,562
15.6	SQL Hint	1,563
15.7	SQL Trace Log	1,735
<b>16.</b>	<b>Built-in Data Type References</b>	<b>1,741</b>
16.1	Aliases of Built-in Data Types	1,742
16.2	BINARY	1,745
16.3	BINARY VARYING	1,746
16.4	BINARY LONG VARYING	1,747
16.5	BOOLEAN	1,748
16.6	CHARACTER	1,749
16.7	CHARACTER VARYING	1,751
16.8	CHARACTER LONG VARYING	1,752
16.9	DATE	1,753
16.10	FLOAT	1,754
16.11	INTERVAL	1,755
16.12	NATIVE_BIGINT	1,759
16.13	NATIVE_DOUBLE	1,760
16.14	NATIVE_INTEGER	1,761
16.15	NATIVE_REAL	1,762

16.16	NATIVE_SMALLINT	1,763
16.17	NUMBER	1,764
16.18	NUMERIC	1,766
16.19	ROWID	1,768
16.20	TIME	1,769
16.21	TIMESTAMP	1,770
<b>17.</b>	<b>Built-in Function References</b>	<b>1,771</b>
17.1	* (MULTIPLICATION)	1,772
17.2	+ (ADDITION)	1,774
17.3	+ (POSITIVE)	1,776
17.4	- (NEGATIVE)	1,777
17.5	- (SUBTRACTION)	1,778
17.6	/ (DIVISION)	1,781
17.7	(CONCATENATE)	1,783
17.8	ABS	1,785
17.9	ACOS	1,786
17.10	ADDDATE	1,787
17.11	ADDTIME	1,788
17.12	ADD_MONTHS	1,789
17.13	ASCII	1,790
17.14	ASIN	1,791
17.15	ATAN	1,792
17.16	ATAN2	1,793
17.17	AVG	1,794
17.18	BITAND	1,795
17.19	BITNOT	1,796
17.20	BITOR	1,797
17.21	BITXOR	1,798
17.22	BIT_LENGTH	1,799
17.23	BYTE_LENGTH	1,800
17.24	CASE2	1,801
17.25	CBRT	1,803
17.26	CEIL	1,804
17.27	CHAR_LENGTH	1,805
17.28	CHR	1,806
17.29	CLOCK_DATE	1,807
17.30	CLOCK_LOCALTIME	1,808
17.31	CLOCK_LOCALTIMESTAMP	1,809
17.32	CLOCK_TIME	1,810

17.33	CLOCK_TIMESTAMP	1,811
17.34	COALESCE	1,812
17.35	CONCAT	1,814
17.36	CONCATENATE	1,815
17.37	COS	1,816
17.38	COT	1,817
17.39	COUNT	1,818
17.40	COUNT(*)	1,819
17.41	CURRENT_CATALOG	1,820
17.42	CURRENT_DATE	1,821
17.43	CURRENT_SCHEMA	1,822
17.44	CURRENT_TIME	1,823
17.45	CURRENT_TIMESTAMP	1,824
17.46	CURRENT_USER	1,825
17.47	CURRVAL	1,826
17.48	DATEADD	1,827
17.49	DATEDIFF	1,829
17.50	DATE_ADD	1,831
17.51	DATE_PART	1,832
17.52	DECODE	1,834
17.53	DEGREES	1,836
17.54	DIGEST	1,837
17.55	DUMP	1,838
17.56	EXP	1,839
17.57	EXTRACT	1,840
17.58	FACTORIAL	1,842
17.59	FLOOR	1,843
17.60	FROM_BASE64	1,844
17.61	FROM_TZ	1,845
17.62	GREATEST	1,846
17.63	HEX	1,847
17.64	INITCAP	1,848
17.65	INSTR	1,849
17.66	LAST_DAY	1,851
17.67	LAST_IDENTITY_VALUE	1,852
17.68	LEAST	1,855
17.69	LENGTH	1,856
17.70	LENGTHB	1,857
17.71	LN	1,858

17.72	LNNVL	1,859
17.73	LOCALTIME	1,860
17.74	LOCALTIMESTAMP	1,861
17.75	LOCAL_GROUP_ID	1,862
17.76	LOCAL_GROUP_NAME	1,863
17.77	LOCAL_MEMBER_ID	1,864
17.78	LOCAL_MEMBER_NAME	1,865
17.79	LOG	1,866
17.80	LOGON_USER	1,867
17.81	LOWER	1,868
17.82	LPAD	1,869
17.83	LTRIM	1,871
17.84	MAX	1,872
17.85	MIN	1,873
17.86	MOD	1,874
17.87	MONTHS_BETWEEN	1,875
17.88	NEXT_DAY	1,877
17.89	NEXTVAL	1,879
17.90	NULLIF	1,880
17.91	NUMTODSINTERVAL	1,881
17.92	NUMTOYMINTERVAL	1,883
17.93	NVL	1,884
17.94	NVL2	1,885
17.95	OCTET_LENGTH	1,886
17.96	OVERLAY	1,888
17.97	PHYSICAL_LENGTH	1,890
17.98	PI	1,892
17.99	POSITION	1,893
17.100	POWER	1,894
17.101	RADIANS	1,895
17.102	RANDOM	1,896
17.103	REPEAT	1,897
17.104	REPLACE	1,898
17.105	REVERSE	1,899
17.106	ROUND( number )	1,901
17.107	ROUND( date )	1,902
17.108	ROWID_GRID_BLOCK_ID	1,904
17.109	ROWID_GRID_BLOCK_SEQ	1,905
17.110	ROWID_MEMBER_ID	1,906

17.111	ROWID_OBJECT_ID	1,907
17.112	ROWID_PAGE_ID	1,908
17.113	ROWID_ROW_NUMBER	1,909
17.114	ROWID_SHARD_ID	1,910
17.115	ROWID_TABLESPACE_ID	1,911
17.116	ROWNUM	1,912
17.117	RPAD	1,916
17.118	RTRIM	1,918
17.119	SESSION_ID	1,920
17.120	SESSION_SERIAL	1,921
17.121	SESSION_USER	1,922
17.122	SHARD_GROUP_ID	1,923
17.123	SHARD_GROUP_NAME	1,925
17.124	SHARD_ID	1,927
17.125	SHARD_NAME	1,929
17.126	SHIFT_LEFT	1,931
17.127	SHIFT_RIGHT	1,932
17.128	SIGN	1,933
17.129	SIN	1,934
17.130	SPLIT_PART	1,935
17.131	SQRT	1,936
17.132	STATEMENT_DATE	1,937
17.133	STATEMENT_LOCALTIME	1,938
17.134	STATEMENT_LOCALTIMESTAMP	1,939
17.135	STATEMENT_TIME	1,940
17.136	STATEMENT_TIMESTAMP	1,941
17.137	STATEMENT_VIEW_SCN	1,942
17.138	STATEMENT_VIEW_SCN_DCN	1,943
17.139	STATEMENT_VIEW_SCN_GCN	1,944
17.140	STATEMENT_VIEW_SCN_LCN	1,945
17.141	STDDEV	1,946
17.142	STDDEV_POP	1,948
17.143	STDDEV_SAMP	1,950
17.144	SUBSTR	1,952
17.145	SUBSTRB	1,953
17.146	SUBSTRING	1,954
17.147	SUM	1,956
17.148	SYSDATE	1,957
17.149	SYS_EXTRACT_UTC	1,958



17.150	SYSTIME	1,959
17.151	SYSTIMESTAMP	1,960
17.152	TAN	1,961
17.153	TO_BASE64	1,962
17.154	TO_CHAR( datetime )	1,963
17.155	TO_CHAR( number )	1,965
17.156	TO_DATE	1,966
17.157	TO_NATIVE_BIGINT	1,968
17.158	TO_NATIVE_DOUBLE	1,969
17.159	TO_NATIVE_INTEGER	1,970
17.160	TO_NATIVE_REAL	1,971
17.161	TO_NATIVE_SMALLINT	1,972
17.162	TO_NUMBER	1,973
17.163	TO_TIME	1,974
17.164	TO_TIME_TZ	1,976
17.165	TO_TIME_WITH_TIME_ZONE	1,977
17.166	TO_TIMESTAMP	1,979
17.167	TO_TIMESTAMP_TZ	1,981
17.168	TO_TIMESTAMP_WITH_TIME_ZONE	1,982
17.169	TRANSACTION_DATE	1,984
17.170	TRANSACTION_LOCALTIME	1,985
17.171	TRANSACTION_LOCALTIMESTAMP	1,986
17.172	TRANSACTION_TIME	1,987
17.173	TRANSACTION_TIMESTAMP	1,988
17.174	TRANSLATE	1,989
17.175	TRIM	1,991
17.176	TRUNC( number )	1,993
17.177	TRUNC( date )	1,994
17.178	UPPER	1,996
17.179	UNHEX	1,997
17.180	UNHEX_TO_CHARSTR	1,998
17.181	USER_ID	1,999
17.182	UUID	2,000
17.183	VAR_POP	2,001
17.184	VAR_SAMP	2,003
17.185	VARIANCE	2,005
17.186	VERSION	2,007
17.187	WIDTH_BUCKET	2,008
<b>18.</b>	<b>SQL References (A~B)</b>	<b>2,009</b>

18.1	ALTER AUDIT POLICY	2,010
18.2	ALTER CLUSTER GROUP name ADD MEMBER	2,013
18.3	ALTER CLUSTER GROUP name OFFLINE MEMBER	2,017
18.4	ALTER CLUSTER LOCATION	2,019
18.5	ALTER DATABASE ADD LOGFILE	2,021
18.6	ALTER DATABASE ARCHIVELOG	2,024
18.7	ALTER DATABASE BACKUP	2,026
18.8	ALTER DATABASE CLEAR AUDIT TRAIL	2,030
18.9	ALTER DATABASE CLEAR PASSWORD HISTORY	2,032
18.10	ALTER DATABASE DATAFILE AUTOEXTEND	2,034
18.11	ALTER DATABASE DELETE BACKUP	2,037
18.12	ALTER DATABASE DROP INACTIVE CLUSTER MEMBERS	2,040
18.13	ALTER DATABASE DROP LOGFILE	2,043
18.14	ALTER DATABASE MOVE SHARD	2,046
18.15	ALTER DATABASE OFFLINE INACTIVE CLUSTER MEMBERS	2,049
18.16	ALTER DATABASE REBALANCE	2,051
18.17	ALTER DATABASE REBALANCE EXCLUDE CLUSTER GROUP	2,054
18.18	ALTER DATABASE RECOVER	2,057
18.19	ALTER DATABASE REGISTER	2,062
18.20	ALTER DATABASE RENAME LOGFILE	2,064
18.21	ALTER DATABASE RESET LOCAL CLUSTER MEMBER	2,066
18.22	ALTER DATABASE RESTORE	2,068
18.23	ALTER INDEX	2,071
18.24	ALTER INDEX name AGING	2,073
18.25	ALTER INDEX name REBUILD	2,075
18.26	ALTER INDEX name RENAME TO	2,081
18.27	ALTER INDEX name STORAGE	2,083
18.28	ALTER PROFILE	2,087
18.29	ALTER SEQUENCE	2,091
18.30	ALTER SESSION CLEANUP GLOBAL TEMPORARY SEGMENT POOL;	2,097
18.31	ALTER SESSION SET property_name	2,099
18.32	ALTER SYSTEM CHECKPOINT	2,101
18.33	ALTER SYSTEM CLEANUP BUFFER_CACHE	2,103
18.34	ALTER SYSTEM CLEANUP PLAN	2,105
18.35	ALTER SYSTEM IRRECOVERABLE CLUSTER MEMBER	2,107
18.36	ALTER SYSTEM JOIN DATABASE	2,109
18.37	ALTER SYSTEM [KILL   DISCONNECT] SESSION	2,112
18.38	ALTER SYSTEM {MOUNT   OPEN} DATABASE	2,115
18.39	ALTER SYSTEM RECONNECT GLOBAL CONNECTION	2,118

18.40	ALTER SYSTEM RESET property_name	2,120
18.41	ALTER SYSTEM SET property_name	2,123
18.42	ALTER SYSTEM SWITCH LOGFILE	2,127
18.43	ALTER TABLE	2,129
18.44	ALTER TABLE name ADD COLUMN	2,134
18.45	ALTER TABLE name ADD CONSTRAINT	2,138
18.46	ALTER TABLE name ADD GLOBAL SECONDARY INDEX	2,141
18.47	ALTER TABLE name ADD SUPPLEMENTAL LOG	2,147
18.48	ALTER TABLE name ALTER COLUMN	2,149
18.49	ALTER TABLE name ALTER CONSTRAINT	2,161
18.50	ALTER TABLE name ALTER GLOBAL SECONDARY INDEX	2,164
18.51	ALTER TABLE name DROP CONSTRAINT	2,169
18.52	ALTER TABLE name DROP GLOBAL SECONDARY INDEX	2,172
18.53	ALTER TABLE name DROP SUPPLEMENTAL LOG	2,174
18.54	ALTER TABLE name MERGE SHARDS	2,176
18.55	ALTER TABLE name MOVE SHARD	2,180
18.56	ALTER TABLE name READ { ONLY   WRITE }	2,183
18.57	ALTER TABLE name REBALANCE	2,186
18.58	ALTER TABLE name REBALANCE EXCLUDE CLUSTER GROUP cluster_group_list	2,188
18.59	ALTER TABLE name REBUILD GLOBAL SECONDARY INDEX	2,191
18.60	ALTER TABLE name RENAME COLUMN	2,197
18.61	ALTER TABLE name RENAME CONSTRAINT	2,199
18.62	ALTER TABLE name RENAME SHARD	2,202
18.63	ALTER TABLE name RENAME TO	2,205
18.64	ALTER TABLE name SET UNUSED COLUMN	2,207
18.65	ALTER TABLE name SPLIT SHARD	2,210
18.66	ALTER TABLE name STORAGE	2,214
18.67	ALTER TABLESPACE	2,217
18.68	ALTER TABLESPACE name ADD [DATAFILE MEMORY]	2,220
18.69	ALTER TABLESPACE name BACKUP	2,224
18.70	ALTER TABLESPACE name DROP [DATAFILE MEMORY]	2,227
18.71	ALTER TABLESPACE name [ONLINE OFFLINE]	2,229
18.72	ALTER TABLESPACE name RENAME DATAFILE	2,232
18.73	ALTER TABLESPACE name RENAME TO	2,234
18.74	ALTER USER	2,236
18.75	ALTER VIEW	2,243
18.76	ANALYZE SYSTEM	2,246
18.77	ANALYZE TABLE	2,249
18.78	AUDIT POLICY	2,256

<b>19. SQL References (C~G)</b>	<b>2,263</b>
19.1 CLOSE cursor_name	2,264
19.2 COMMENT ON name IS	2,266
19.3 COMMIT	2,272
19.4 CREATE AUDIT POLICY	2,275
19.5 CREATE CLUSTER GROUP	2,282
19.6 CREATE CLUSTER LOCATION	2,286
19.7 CREATE DISK DATA TABLESPACE	2,288
19.8 CREATE GLOBAL TEMPORARY TABLE	2,292
19.9 CREATE IMMUTABLE TABLE	2,297
19.10 CREATE INDEX	2,301
19.11 CREATE MEMORY DATA TABLESPACE	2,309
19.12 CREATE MEMORY TEMPORARY TABLESPACE	2,313
19.13 CREATE PROFILE	2,317
19.14 CREATE SCHEMA	2,328
19.15 CREATE SEQUENCE	2,333
19.16 CREATE SYNONYM	2,339
19.17 CREATE TABLE	2,343
19.18 CREATE TABLE AS SELECT	2,378
19.19 CREATE TABLESPACE	2,385
19.20 CREATE USER	2,387
19.21 CREATE VIEW	2,394
19.22 DECLARE cursor_name	2,399
19.23 DELETE FROM	2,412
19.24 DELETE FROM name RETURNING	2,416
19.25 DELETE FROM name RETURNING .. INTO	2,420
19.26 DELETE FROM name WHERE CURRENT OF cursor_name	2,424
19.27 DROP AUDIT POLICY	2,428
19.28 DROP CLUSTER GROUP	2,430
19.29 DROP CLUSTER LOCATION	2,432
19.30 DROP INDEX	2,434
19.31 DROP PROFILE	2,436
19.32 DROP SCHEMA	2,438
19.33 DROP SEQUENCE	2,441
19.34 DROP SYNONYM	2,444
19.35 DROP TABLE	2,447
19.36 DROP TABLESPACE	2,451
19.37 DROP USER	2,454
19.38 DROP VIEW	2,458

19.39	EXECUTE IMMEDIATE 'sql_string'	2,460
19.40	EXECUTE statement_name	2,463
19.41	FETCH cursor_name	2,468
19.42	FLASHBACK TABLE	2,474
19.43	GRANT privileges TO	2,477
<b>20.</b>	<b>SQL References (H~Z)</b>	<b>2,491</b>
20.1	INSERT INTO	2,492
20.2	INSERT INTO name RETURNING	2,497
20.3	INSERT INTO name RETURNING .. INTO	2,501
20.4	INSERT INTO name ... UPDATE	2,505
20.5	INSERT INTO name ... UPDATE RETURNING	2,512
20.6	INSERT INTO name ... UPDATE RETURNING ... INTO	2,517
20.7	LOCK TABLE	2,522
20.8	NOAUDIT POLICY	2,526
20.9	OPEN cursor_name	2,532
20.10	PREPARE statement_name	2,536
20.11	PURGE	2,541
20.12	RELEASE SAVEPOINT savepoint_specifier	2,546
20.13	REVOKE privileges FROM	2,548
20.14	ROLLBACK	2,552
20.15	SAVEPOINT savepoint_specifier	2,556
20.16	SELECT	2,559
20.17	SELECT .. FOR UPDATE	2,653
20.18	SELECT .. INTO	2,658
20.19	SELECT .. INTO .. FOR UPDATE	2,661
20.20	SET CONSTRAINTS	2,667
20.21	SET SCHEMA schema_name	2,676
20.22	SET SESSION AUTHORIZATION user_identifier	2,679
20.23	SET SESSION CHARACTERISTICS AS transaction_mode	2,681
20.24	SET TIME ZONE	2,683
20.25	SET TRANSACTION transaction_mode	2,685
20.26	TRUNCATE TABLE	2,687
20.27	UPDATE	2,690
20.28	UPDATE name RETURNING	2,695
20.29	UPDATE name RETURNING .. INTO	2,699
20.30	UPDATE name WHERE CURRENT OF cursor_name	2,703
<b>Part IV.</b>	<b>PSM Manual</b>	<b>2,707</b>

<b>21. Overview of PSM</b>	<b>2,723</b>
21.1 Features of PSM	2,724
21.2 Language Elements	2,726
21.3 Processing Transaction in PSM	2,727
<b>22. PSM DataTypes</b>	<b>2,729</b>
22.1 Built-in Data Types	2,730
22.2 Attribute Data Types	2,733
22.3 User-defined Record Type	2,735
22.4 User-defined Collection Type	2,737
22.5 SYS_REFCURSOR	2,745
<b>23. PSM Control Statements</b>	<b>2,747</b>
23.1 Assignment	2,748
23.2 PL Block	2,752
23.3 NULL Statement	2,755
23.4 Testing Conditions	2,756
23.5 Iterative Control	2,759
23.6 Sequential Control	2,763
23.7 Error Handling	2,769
<b>24. PSM Cursor Statements</b>	<b>2,783</b>
24.1 Declaration	2,784
24.2 OPEN	2,788
24.3 FETCH	2,789
24.4 CLOSE	2,791
24.5 EXPLICIT CURSOR ATTRIBUTES	2,792
24.6 IMPLICIT_CURSOR_ATTRIBUTES	2,794
24.7 CURSOR VARIABLES	2,796
<b>25. Using PSM Subprograms</b>	<b>2,803</b>
25.1 Anonymous PL Block	2,804
25.2 Nested Procedure	2,805
25.3 Nested Function	2,807
25.4 Schema-level Procedure	2,808
25.5 Schema-level Function	2,813
25.6 Built-in Procedures	2,816
<b>26. Using SQLs in PSM</b>	<b>2,819</b>
26.1 Static SQLs	2,820
26.2 Dynamic SQL	2,837
<b>27. PSM Packages</b>	<b>2,843</b>
27.1 Definition	2,844

27.2	Features	2,844
27.3	Specification	2,845
<b>28.</b>	<b>PSM Language Element References</b>	<b>2,849</b>
28.1	Assignment Statement	2,850
28.2	Basic LOOP Statement	2,854
28.3	Block (BEGIN .. END)	2,856
28.4	CASE Statement	2,860
28.5	CLOSE Statement	2,863
28.6	Collection Method Invocation	2,865
28.7	COLLECTION Variable Declaration	2,869
28.8	CONTINUE Statement	2,873
28.9	Cursor FOR LOOP Statement	2,876
28.10	Cursor Variable Declaration	2,880
28.11	DELETE Statement Extension	2,882
28.12	EXCEPTION_INIT Pragma	2,885
28.13	Exception Declaration	2,887
28.14	Exception Handler	2,889
28.15	EXECUTE IMMEDIATE Statement	2,892
28.16	EXIT Statement	2,896
28.17	Explicit Cursor Attribute	2,898
28.18	Explicit Cursor Declaration and Definition	2,901
28.19	FETCH Statement	2,905
28.20	FOR LOOP Statement	2,908
28.21	Function Declaration and Definition	2,911
28.22	GOTO Statement	2,914
28.23	IF Statement	2,916
28.24	Implicit Cursor Attribute	2,918
28.25	INSERT Statement Extension	2,920
28.26	INSERT INTO ... UPDATE Statement Extension	2,923
28.27	NULL Statement	2,928
28.28	OPEN Statement	2,930
28.29	OPEN FOR Statement	2,933
28.30	Procedure Call	2,936
28.31	Procedure Declaration and Definition	2,939
28.32	RAISE Statement	2,941
28.33	Record Variable Declaration	2,944
28.34	RETURN Statement	2,946
28.35	RETURNING INTO clause	2,948
28.36	%ROWTYPE Attribute	2,950

28.37	Scalar Variable Declaration	2,952
28.38	SELECT INTO Statement	2,955
28.39	SQLCODE Function	2,957
28.40	SQLERRM Function	2,959
28.41	%TYPE Attribute	2,961
28.42	UPDATE Statement Extension	2,963
28.43	WHILE LOOP Statement	2,966
<b>29.</b>	<b>PSM SQL References</b>	<b>2,969</b>
29.1	ALTER FUNCTION	2,970
29.2	ALTER PACKAGE	2,972
29.3	ALTER PROCEDURE	2,974
29.4	CALL Statement	2,977
29.5	CREATE FUNCTION	2,980
29.6	CREATE PACKAGE	2,985
29.7	CREATE PACKAGE BODY	2,989
29.8	CREATE PROCEDURE	2,993
29.9	DROP FUNCTION	2,998
29.10	DROP PACKAGE	3,001
29.11	DROP PROCEDURE	3,003
<b>Part V.</b>	<b>Developer Manual</b>	<b>3,007</b>
<b>30.</b>	<b>Database Connection</b>	<b>3,015</b>
30.1	Features	3,016
30.2	Selecting Execution Member	3,017
30.3	Global Session	3,019
30.4	Constraints	3,020
30.5	Settings	3,022
<b>31.</b>	<b>ODBC</b>	<b>3,023</b>
31.1	Overview of GOLDILOCKS ODBC Driver	3,024
31.2	Data Source Configuration	3,027
31.3	GLOBAL CONNECTION	3,038
31.4	Catalog Function	3,046
31.5	ODBC API References	3,051
31.6	XA API References	3,394
<b>32.</b>	<b>JDBC</b>	<b>3,411</b>
32.1	Overview of GOLDILOCKS JDBC Driver	3,412
32.2	Feature Specification	3,417
32.3	JDBC API References	3,449



<b>33. Embedded SQL</b>	<b>3,643</b>
33.1 Precompiler	3,644
33.2 Embedded SQL	3,655
33.3 Advanced Topic	3,770
33.4 Embedded SQL Reference	3,812
<b>34. PDO</b>	<b>3,841</b>
34.1 Overview of PDO	3,842
34.2 Installation /Configuration	3,842
34.3 Usage	3,844
34.4 Examples	3,845
<b>35. PyDBC</b>	<b>3,855</b>
35.1 GOLDBLOCKS PyDBC	3,856
35.2 API Reference	3,859
35.3 Exception	3,874
35.4 Data Type	3,875
<b>36. Hibernate</b>	<b>3,879</b>
36.1 Overview	3,880
36.2 Interworking with Hibernate	3,880
36.3 Examples	3,882
<b>Part VI. Utility Manual</b>	<b>3,889</b>
<b>37. gcreatedb</b>	<b>3,897</b>
37.1 Overview of gcreatedb	3,898
37.2 Command Option	3,900
<b>38. glsnr</b>	<b>3,905</b>
38.1 Overview of glsnr	3,906
38.2 Command Options	3,907
38.3 Listener Configuration	3,910
<b>39. gsql/gsqlnet (Interactive SQL Tool)</b>	<b>3,915</b>
39.1 Overview of gsql	3,916
39.2 Executing gsql	3,920
39.3 Using Interactive Command	3,926
39.4 Command Option Reference	3,964
39.5 Interactive Command References	3,972
<b>40. gloder/gloadernet(Upload/download Tool)</b>	<b>4,053</b>
40.1 Overview of gloder and gloadernet	4,054
40.2 Using gloder	4,058

- 40.3 Control File Syntax ..... 4,081
- 40.4 gloder Argument References ..... 4,088
- 41. gdump ..... 4,103**
  - 41.1 Overview of gdump ..... 4,104
  - 41.2 Examples of Using gdump ..... 4,107
- 42. tablediff ..... 4,121**
  - 42.1 Overview of tablediff ..... 4,122
  - 42.2 Usage ..... 4,124
- 43. gsyncher ..... 4,131**
  - 43.1 Overview of gsyncher ..... 4,132
  - 43.2 Examples ..... 4,133
- 44. gmon ..... 4,137**
  - 44.1 Overview of gmon ..... 4,138
  - 44.2 Examples ..... 4,140
- 45. gtrclogger ..... 4,141**
  - 45.1 Overview of gtrclogger ..... 4,142
  - 45.2 Examples ..... 4,144
- 46. glocator ..... 4,145**
  - 46.1 Overview of glocator ..... 4,146
  - 46.2 Using glocator ..... 4,150
  - 46.3 Features of glocator ..... 4,153
  - 46.4 glocator Configuration ..... 4,155
- 47. gagent ..... 4,163**
  - 47.1 Overview of gagent ..... 4,164
  - 47.2 gagent Configuration ..... 4,168
- 48. gloctl ..... 4,173**
  - 48.1 Overview of gloctl ..... 4,174
  - 48.2 Interactive Command References ..... 4,178
  - 48.3 Location File ..... 4,184
  - 48.4 Configuration ..... 4,186
- Part VII. Replication ..... 4,189**
- 49. Overview ..... 4,193**
  - 49.1 Overview of GOLDILOCKS Replication ..... 4,194
  - 49.2 Characteristics ..... 4,195
- 50. CYCLONE ..... 4,197**
  - 50.1 CYCLONE ..... 4,198

50.2	Requirements	4,206
50.3	Configuration	4,210
50.4	Operating	4,230
50.5	Operating Examples	4,236
50.6	Operating CYCLONE in Cluster	4,243
50.7	Monitoring (CYMON)	4,248
<b>51.</b>	<b>LOGMIRROR</b>	<b>4,253</b>
51.1	LOGMIRROR	4,254
51.2	Requirements	4,256
51.3	Configuration	4,258
51.4	Operating	4,262
51.5	Examples of Interworking with CYCLONE	4,264
<b>52.</b>	<b>CYFILE</b>	<b>4,271</b>
52.1	CYFILE	4,272
52.2	Requirements	4,274
52.3	Configuration	4,277
52.4	Operating	4,287
52.5	Files	4,290
<b>Appendix A.</b>	<b>Error Codes</b>	<b>4,297</b>
A.1	OS Related Error	4,298
A.2	Datatype and Operation Related Error	4,302
A.3	Resource Management Related Error	4,308
A.4	Storage Management Related Error	4,310
A.5	Dictionary Cash Related Error	4,315
A.6	SQL Handling Related Error	4,316
A.7	PSM Related Error	4,332
A.8	Session Related Error	4,335
A.9	ODBC Related Error	4,336
A.10	JDBC Related Error	4,338
A.11	Embedded SQL Related Error	4,340
A.12	Communication Related Error	4,343
A.13	ServerLibrary Related Error	4,344
A.14	gsq/ gsqlnet Related Error	4,345
A.15	gloader/ gloadernet Related Error	4,347
A.16	gmaster Related Error	4,348
A.17	glsnr Related Error	4,349
A.18	cyclone Related Error	4,350
A.19	LogMirror Related Error	4,352

A.20	cymon Related Error	4,353
A.21	gdispatcher Related Error	4,354
A.22	gbalancer Related Error	4,355
A.23	gsyncher Related Error	4,356
A.24	Cluster Related Error	4,357
A.25	cserver Related Error	4,359
A.26	cdispatcher Related Error	4,360
A.27	gtrclogger Related Error	4,361
A.28	glocator Related Error	4,362
A.29	gloctl Related Error	4,363
A.30	gmon Related Error	4,364
A.31	gagent Related Error	4,365
<b>Appendix B.</b>	<b>Wait Event</b>	<b>4,367</b>
B.1	Wait Event	4,368
B.2	Class of Wait Event	4,368
B.3	Item of Wait Event	4,369
<b>Appendix C.</b>	<b>Open Source License</b>	<b>4,387</b>

# Part I.

---

## Getting Started

## 2 | Getting Started

<b>1. Preface</b>	<b>5</b>
1.1 Overview	6
Target Reader	6
1.2 Summary	7
GOLDILOCKS Database Management System	7
GOLDILOCKS Architecture	7
GOLDILOCKS Cluster System Architecture	9
1.3 Characteristics of GOLDILOCKS Cluster	11
Features of Cluster	11
Constraint of Cluster	12
<b>2. Tutorial</b>	<b>15</b>
2.1 Managing GOLDILOCKS Instance	16
Overview	16
Property Setting	16
Background Process	17
Client Process	18
Memory Architecture of Instance	19
Startup and Shutdown Instance	19
Start and End of Listener	21
2.2 Installing GOLDILOCKS and Creating Database	22
Overview	22
Release Platform	22
System Requirements	23
GOLDILOCKS Package Configuration	24
Installing GOLDILOCKS Software	30
Creating Database	36
Building Dictionary Schema Information	39
2.3 Managing Database Memory Structure	40
Database Memory Structure	40
Checking Information of Database Storage Structure	42
General Operation of Data Storage	43
Store Mode	46
2.4 Managing Schema Object	48
Schema Object	48
Schema Object Management Privileges	48
Managing Table	48
Managing Index	49
Sequence	50
2.5 Managing User	51

Creating User .....	51
Dropping User .....	52
Altering User .....	52
2.6 GOLDILOCKS Property .....	55
Properties When Creating Database .....	55
Properties When Driving Database .....	55
2.7 GOLDILOCKS Utility .....	57
gcreatedb .....	57
gsql (GOLDILOCKS Interactive SQL Tool) .....	58
gloader (GOLDILOCKS Data Upload/download Tool) .....	59
<b>3. Cluster Tutorial .....</b>	<b>61</b>
3.1 Managing GOLDILOCKS Cluster System .....	62
Overview .....	62
Property Setting .....	62
Background Process .....	63
Client Process .....	64
Memory Structure of Instance .....	64
Start and End of Cluster System .....	65
3.2 Installing GOLDILOCKS and Creating Database .....	70
Configuring GOLDILOCKS Package .....	70
Installing GOLDILOCKS Software .....	70
Creating Database .....	71
Building Dictionary Schema Information .....	72
3.3 Managing Schema Object .....	74
Managing Table .....	74
Managing Index .....	80
Global Sequence .....	81
3.4 GOLDILOCKS Property .....	85
<b>4. What's New .....</b>	<b>89</b>
4.1 Feature Matrix .....	90
Architecture .....	90
SQL .....	110
API .....	126
Utility .....	136
Replication .....	150
4.2 What's New in GOLDILOCKS 21c.1 .....	156
Architecture .....	156
SQL .....	158
API .....	160

## 4 | Getting Started

Utility .....	162
Replication .....	164
4.3 Patch Notes .....	165
21c.1.30 Patch Notes .....	165
21c.1.29 Patch Notes .....	173
21c.1.28 Patch Notes .....	176
21c.1.27 Patch Notes .....	177
21c.1.26 Patch Notes .....	183
21c.1.25 Patch Notes .....	184
21c.1.24 Patch Notes .....	189
21c.1.23 Patch Notes .....	194
21c.1.22 Patch Notes .....	200
21c.1.21 Patch Notes .....	201
21c.1.20 Patch Notes .....	204
21c.1.19 Patch Notes .....	206
21c.1.18 Patch Notes .....	211
21c.1.17 Patch Notes .....	216
21c.1.16 Patch Notes .....	229
21c.1.15 Patch Notes .....	230
21c.1.14 Patch Notes .....	237
21c.1.13 Patch Notes .....	237
21c.1.12 Patch Notes .....	239
21c.1.11 Patch Notes .....	243
21c.1.10 Patch Notes .....	244
21c.1.9 Patch Notes .....	247
21c.1.8 Patch Notes .....	249
21c.1.7 Patch Notes .....	250
21c.1.6 Patch Notes .....	250
21c.1.5 Patch Notes .....	264
21c.1.4 Patch Notes .....	267
21c.1.3 Patch Notes .....	268
21c.1.2 Patch Notes .....	272
21c.1.1 Patch Notes .....	276



**1.**

---

# **Preface**

## 1.1 Overview

This user manual is intended for the user who is configuring, managing and operating GOLDILOCKS. The purpose of this manual is to convey the basic concepts required for installation and management of GOLDILOCKS. This manual also describes cautions when using GOLDILOCKS system.

- The description which is presented in this document can be changed according to the installation environment and specific usage.
- This document is based on GOLDILOCKS 21c.1 version.
- This document is based on RedHat linux - based platform.

### Target Reader

The target readers are as follows.

- Programmers who need basic knowledge about how to manage GOLDILOCKS database
- Administrators and performance managers of GOLDILOCKS database
- Administrators and performance managers of GOLDILOCKS cluster system

## 1.2 Summary

This chapter describes the basic structure and characteristics of GOLDILOCKS for the novice user. A user can select either a standalone or a cluster system architecture to use GOLDILOCKS. Differences of each architecture and their usages are described.

### GOLDILOCKS Database Management System

GOLDILOCKS is an in-memory relational DBMS. GOLDILOCKS stores all user data in in-memory as a table form so that it performs search and update operations of all such data effectively.

GOLDILOCKS database system consists of the following parts.

- User-installed GOLDILOCKS software binaries
- Database which is a set of tablespaces, implemented with one or more shared memory on in-memory
- Various files for persistence support of database
  - The data files created with the same size as shared memory per shared memory
  - Redo log files which support the recovery of the database in the event of a failure
  - Configuration files for database settings
  - Trace log files which record information such as events during database operations
- gmater processes which manage in-memory database, and many system threads within it

### GOLDILOCKS Architecture

To prevent spreading the application process failure over the entire database system, GOLDILOCKS database is a multi-process architecture based on shared memory, instead of a multi-thread architecture. The overall architecture of GOLDILOCKS database is as shown in figure 1. Data are loaded onto a shared memory and gmater process is a management daemon which manages database such as boot-up, log flush, aging. Also, it stores redo log files and data files on a disk file to ensure the permanence of data. Applications using GOLDILOCKS database will use one of the following two accessing models.

Figure 1 GOLDILOCKS architecture

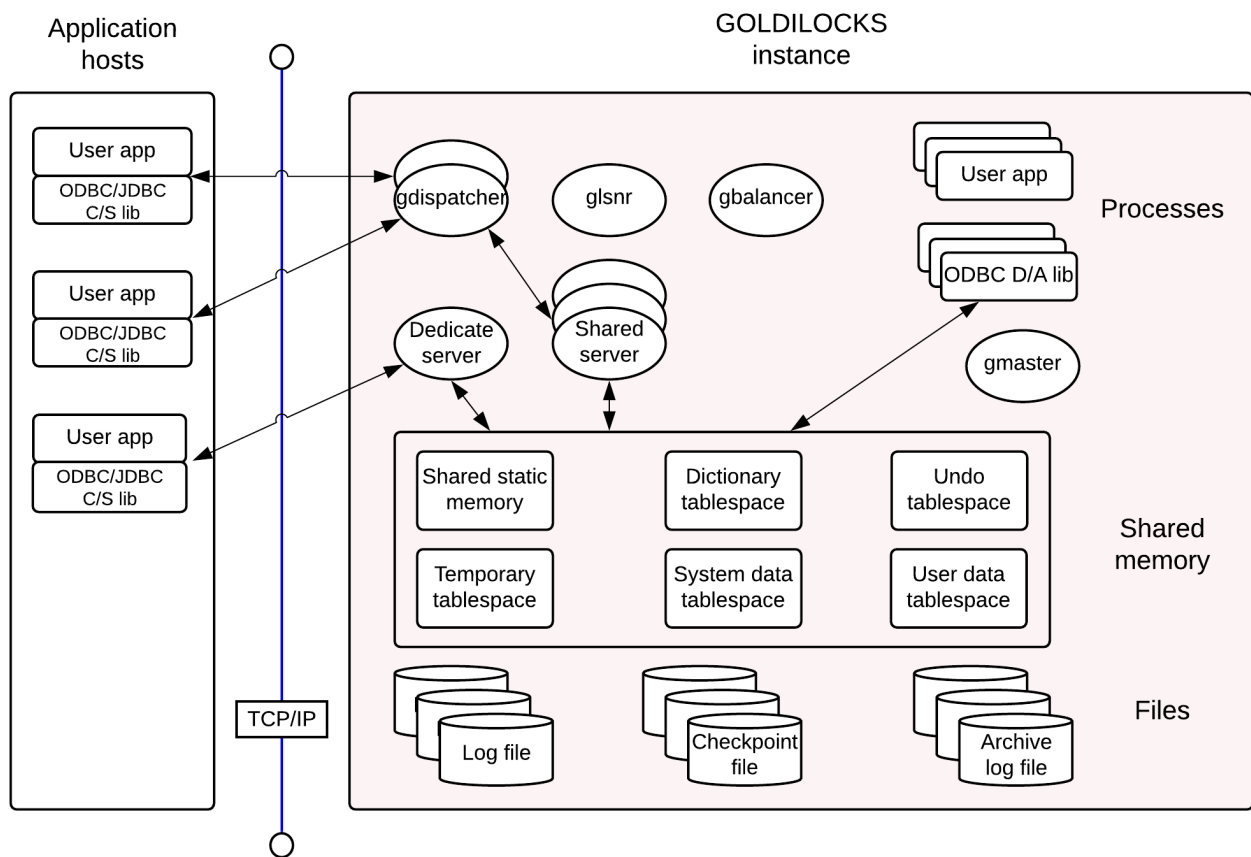

- Direct access (D/A) model
  - A user may use D/A model when user application is operated on the same equipment as GOLDILOCKS database.
  - User applications should be used by linking with GOLDILOCKS ODBC/JDBC libraries for D/A.
  - GOLDILOCKS ODBC/JDBC libraries for D/A include query processing module and storage management module inside and they process user request by directly attaching shared memory configuring that database.
  - It is suitable to implement a few works which require low-latency because the communication load between application process and database process module is removed.
- Client/ Server (C/S) model
  - A user may use C/S model when user application is operated on the same equipment as GOLDILOCKS database or on a different equipment.
  - User applications should be used by linking with GOLDILOCKS ODBC/JDBC libraries for C/S.
  - The GOLDILOCKS development library for C/S processes user's requests through TCP communication with the server (gserver) which serves the database specified in the connect string.
  - The response speed of single application of C/S is inferior to that of D/A. However, C/S does not depend on the location of the application, and the relatively stable operation is possible even when an error occurs in the application.
  - C/S model may be operated in shared mode or dedicated mode. In dedicated mode, a single server (gserver) process is performed on a single client. In shared mode, it responds to multiple client

- s because dispatcher (gdispatcher) and shared-server (gserver) are always running.
- Dedicated mode is suitable for large amount of data, and shared mode is suitable for many clients, small amount of data.
- For more information about setting dedicated mode or shared mode, refer to **odbc.ini File** and **Listener Configuration**.



In D/A model, an application directly accesses to database and manipulates it, and thus the database instance becomes unstable because many errors occur at an early development stages. Therefore, it would be efficient to develop it in C/S model at an early development stage, and then, to switch it to D/A model at the final development stage.

## GOLDILOCKS Cluster System Architecture

GOLDILOCKS can be used by configuring a standalone database, or binding multiple databases into a single cluster and managing the database in cluster unit. In other words, a user can distribute and store table data into multiple nodes according to the desired sharding strategy. This guarantees high availability and improves the throughput due to the parallel processing.

GOLDILOCKS cluster system guarantees ACID of transaction which is cluster-widely performed. Therefore, it provides the data reliability as same as that of the transaction performed on a standalone server when any node belonging to the cluster system is connected to perform the transaction.

Each database belonging to GOLDILOCKS cluster system has a structure for multi-process structure and data loading method, which is as same as the structure of the standalone database. However, cdispatcher process and cluster server (cserver) process are added. cdispatcher is a process for efficient communication between member nodes in a cluster, and cluster server (cserver) process is for the data storage and management on the cluster member node. Also, tablespaces and management areas for transaction management of cluster system are added to the shared memory.

Figure 2 GOLDILOCKS cluster system architecture

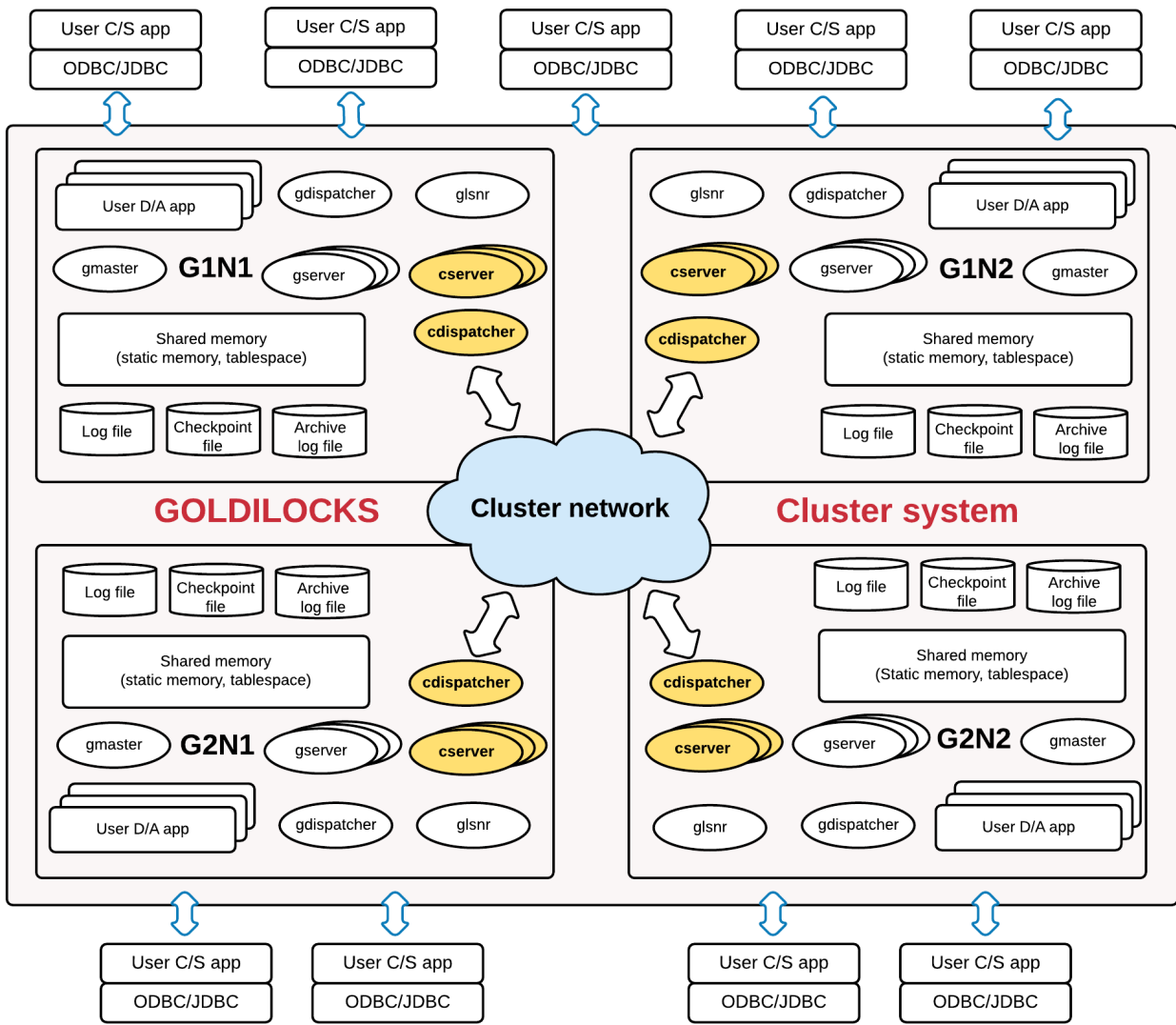

## 1.3 Characteristics of GOLDDILOCKS Cluster

### Features of Cluster

GOLDDILOCKS cluster is a cluster system of shared nothing structure and it overcomes limitations for transaction performance and storage of an existing standalone system.

- High throughput
  - GOLDDILOCKS cluster does not limit creating groups, and the linear performance can be improved by creating groups.
  - It overcomes the limitation for the storage space of the existing memory-based standalone system.
- High availability
  - If a group consists of multiple members and at least one member is running in a group, it does not affect the availability.
  - Even when not every member in a group is available, other groups except for that group normally provides service.
- Online expansion and online recovery
  - creating groups or members are possible even when the service is in progress, and it does not affect the service in progress.
  - Even the member of the suspended service due to an error can participate in a cluster online.
- Providing the perfect transaction
  - It perfectly provides the following properties of which a transaction should comply with.
    - Atomicity
    - Consistency
    - Isolation
    - Durability
- Providing the perfect MVCC (multi-version concurrency control)
  - GOLDDILOCKS cluster provides a global statement level consistency as standalone system does.
  - The SQL starting at a specific point can access a desired version among the various versions when accessing to any node.
- Providing the standard SQL and the standard DBC
  - It provides SQL which is equivalent to SQL 92.
  - It provides standard DBCs such as JDBC, ODBC.
- Application compatibility
  - The application source or SQL developed in the existing standalone system can be used in GOLDDILOCKS cluster without modifying it.

## Constraint of Cluster

All SQL statements in GOLDBLOCKS cluster can be used same as those in standalone system except for the following constraints.



PRIMARY KEY for the sharded table, UNIQUE constraint and the UNIQUE INDEX should include a sharding key.

The following is an example of a failure because the constraint of UNIQUE (name) does not include an id column which is a sharding key.

```
gSQL>
CREATE TABLE t1
(
  id  INTEGER PRIMARY KEY,
  name VARCHAR(128),
  UNIQUE (name)
)
SHARDING BY HASH(id);
ERR-HYC00(16380): UNIQUE or PRIMARY KEY must include all sharding key columns for cluster
system
```

The constraint should be generated including sharding key as like UNIQUE ( id, name ) or UNIQUE ( name, id ) in the following example.

```
gSQL>
CREATE TABLE t1
(
  id  INTEGER PRIMARY KEY,
  name VARCHAR(128),
  UNIQUE( id, name )
)
SHARDING BY HASH (id);
Table created.
```



Non-deterministic statements should have the global secondary index to distinguish the same rows among the cluster members.

The following is an example of error which occurs when creating a table omitting the global secondary in



dex by force.

```
gSQL> CREATE TABLE t1 ( c1 INTEGER ) WITHOUT GLOBAL SECONDARY INDEX;
Table created.
gSQL> INSERT INTO t1 VALUES (1), (2), (3), (4), (5);
5 rows created.
gSQL> COMMIT;
Commit complete.
```

The following is an example of deleting three rows and it does not guarantee that the cluster members delete the same rows.

```
gSQL> DELETE FROM t1 FETCH 3;
ERR-42000(16423): does not support non-deterministic DML in the cluster system : global
secondary index expected
```

The following example does not guarantee that the cluster members update the same rows to the same value by using RANDOM(1, 100).

```
gSQL> UPDATE t1 SET c1 = RANDOM(1, 100);
ERR-42000(16423): does not support non-deterministic DML in the cluster system : global
secondary index expected
```

The following is an example of updating the row at the current position by using updatable cursor, and it requires the global secondary index to distinguish the same rows among cluster members.

```
gSQL> \var v1 INTEGER
gSQL> DECLARE cur1 CURSOR FOR SELECT c1 FROM t1 FOR UPDATE;
Cursor declared.
gSQL> OPEN cur1;
Cursor is open.
gSQL> FETCH cur1 INTO :v1;
V1
--
1
1 row fetched.
gSQL> UPDATE t1 SET c1 = 1 WHERE CURRENT OF cur1;
ERR-42000(16423): does not support non-deterministic DML in the cluster system : global
secondary index expected
```



It does not support the deferrable constraint.

```
gSQL> ALTER TABLE t1 ADD CONSTRAINT t1_uk UNIQUE(id) DEFERRABLE;
ERR-HYC00(16388): does not support deferrable constraints in the cluster system :
ALTER TABLE t1 ADD CONSTRAINT t1_uk UNIQUE(id) DEFERRABLE
                                *
ERROR at line 1:
```



It does not guarantee the sequence when using the same sequence in different servers.

- It is executed in g1n1 server.

```
gSQL> SELECT seq1.NEXTVAL FROM dual;
NEXTVAL
-----
      1
1 row selected.
gSQL> SELECT seq1.NEXTVAL FROM dual;
NEXTVAL
-----
      2
1 row selected.
```

- It is executed in g2n1 server.

```
gSQL> SELECT seq1.NEXTVAL FROM dual;
NEXTVAL
-----
     21
1 row selected.
```

- It is executed again in g1n1 server.

```
gSQL> SELECT seq1.NEXTVAL FROM dual;
NEXTVAL
-----
      3
1 row selected.
```

2.

---

## Tutorial

## 2.1 Managing GOLDDILOCKS Instance

This chapter describes the basic knowledge of managing the GOLDDILOCKS instance.

### Overview

GOLDDILOCKS database system consists of database and instance. Database is a collection of various files which are necessary for driving database such as dictionary data on memory, user data, data file for dictionary data and user data, online redo files.

Database instance consists of two parts. One is the memory portions containing the run-time information for operating GOLDDILOCKS database, and the other is the background process which is used to operate and manage it. Each database instance is identified as shared memory key value and "GOLDDILOCKS\_DATA" environment variable value, both are used to configure shared memory.

### Property Setting

GOLDDILOCKS properties are listed in `$GOLDDILOCKS_DATA/conf/golddilocks.properties.conf` file. A user may install GOLDDILOCKS using the basic properties. This chapter describes the main properties such as TBS (Tablespace), LOG, CONTROL FILE.

The followings describe main property items of when installing GOLDDILOCKS.

**Table 2-1** Main property items

Property	Description	Default value
SYSTEM_TABLESPACE_DIR	It is the directory path of installing the following system TBS. <ul style="list-style-type: none"> <li>• DICTIONARY_TBS</li> <li>• MEM_DATA_TBS</li> <li>• MEM_UNDO_TBS</li> <li>• MEM_TEMP_TBS</li> <li>• MEM_TRANS_TBS</li> </ul>	'<GOLDDILOCKS_DATA>/db'
SYSTEM_MEMORY_DICT_TABLESPACE_SIZE	It is the dictionary tablespace size.	128M
SYSTEM_MEMORY_DATA_TABLESPACE_SIZE	It is the memory data tablespace size.	200M
SYSTEM_DISK_DATA_TABLESPACE_SIZE	It is the disk data tablespace size.	200M
SYSTEM_MEMORY_UNDO	It is the undo tablespace size.	32M

Property	Description	Default value
DO_TABLESPACE_SIZE		
LOG_DIR	It is the default log directory path.	'<GOLDDILOCKS_DATA>/wal'
SYSTEM_LOGGER_DIR	It is the system log directory path.	'<GOLDDILOCKS_DATA>/trc'
CONTROL_FILE_COUNT	It is the number of control files.	2
CONTROL_FILE_0	It is the first control file path.	'<GOLDDILOCKS_DATA>/wal/control_0.ctl'
CONTROL_FILE_1	It is the second control file path.	'<GOLDDILOCKS_DATA>/wal/control_1.ctl'
BUFFER_CACHE_SIZE	It is the size of the buffer cache which is used to cache the table and the index page created in the disk tablespace.	64M



- **DICTIONARY\_TBS:** It is the tablespace which stores dictionary tables of GOLDDILOCKS.
- **MEM\_DATA\_TBS:** It is the memory tablespace in which the user table/index is generated.
- **DISK\_DATA\_TBS:** It is the disk tablespace in which the user table/index is generated.
- **MEM\_UNDO\_TBS:** It is the tablespace which contains the undo (rollback) information of the transaction.
- **MEM\_TRANS\_TBS (Cluster only):** It is the tablespace used for the global transaction recovery in cluster system. The size is automatically calculated based on the transaction table size and the number of cluster node.

A user can change the text property file (\$GOLDDILOCKS\_DATA/conf/golddilocks.properties.conf), or define a new variable in the form of GOLDDILOCKS\_<property\_name> to change the database settings or instance settings. In the priority, the property file takes precedence over the environment variable.

## Background Process

GOLDDILOCKS has a background process (gmaster) for managing instance. gmaster consists of multiple system thread internally, and the contents are as follows.

**Table 2-2** System threads

Thread	Description
Main thread	It starts or ends gmater process.
Log archiving thread	It copies the previous redo log file to a specified location when switching online redo file, and stores it.
Ager thread	It cleans up the resources being used by dropped schema objects.
Page flusher thread	It distributes the task to the IO slave and controls them in order to store the dirty pages of in-memory into the disk at checkpoint.
Log flusher thread	It periodically collects the log records accumulated in the redo log buffer, and then stores them into online redo log file at run-time.
Checkpoint thread	It downloads the in-memory's changes to the data file on the disk and the online redo log file when switching redo log file.
Cleanup thread	It cleans up resources used by abnormally terminated clients, and then rolls back the transactions.
IO slave thread	It performs all disk IO related to data file such as checkpoint and data file loading.
Process monitor thread	It monitors after executing the processes such as balancer (gbalancer), dispatcher (gdispatcher), shared-server (gserver), then reexecutes when abnormal termination is detected.
Cluster Recover Thread (Cluster only)	It recovers a global transaction in cluster system.
Failover Thread (Cluster only)	It deals with the failover through reselecting offline and coordinator for the members when an error occurs on a specific node or in a network in cluster system.

## Client Process

### Client/ Server Model

The Client/ Server (C/S) model application is connected to listener (glsnr) which is waiting for access request. Then it creates a new database service process (gserver), in dedicated mode, and it handles user's request by using TCP communication. All these operations are carried out through inter process communication, so any signal generated in the application process does not affect on the state of the database. Moreover, cleanup thread regularly checks and returns all the resources used by abnormally terminated application.

### Direct Access Model

GOLDILOCKS supports a direct access (D/A) model as well as Client/ Server (C/S) model. All applications using D/A model are linked to the server library supported by GOLDILOCKS, and then directly access database and instance. Therefore, no other special service process exists but only the application processes exist.

When D/A model application process is interrupted abnormally by the signal generated during operation, all resources in use will be cleaned up by the signal handler function which the library set during connection. The function cleans up the resources according to the two following steps.

1. The signal handler marks an abnormal termination on the session object and terminates the process.
2. The cleanup thread of gmaster return resources to the database in the same way as C/S model after a certain period of time.

Application processes directly access the database area in D/A model. Therefore, comply with the following precautions.

- When the D/A model application process is terminated by a fatal signal such as SEGV, the signal handler which was registered by the library at connection to the database should stop using shared resources. If a specific signal handler should be installed in the application it should be declared before connecting to the database.
- When forcibly shut down the application process, do not use SIGKILL (kill-9) because the process can not detect the generation of the signal. A user should use SIGTERM, SIGQUIT or SIGUSR2.

## Memory Architecture of Instance

The memory size used by the database instance is determined by the relevant properties in the property file. Shared memory used by instance can be divided into static area and tablespace area. Static area includes basic information about public instance, each session, statement, transaction, redo log buffer, dictionary cache and several other operation. Tablespace area includes page frame of each tablespace and Page Control Header (PCH) for controlling them.

The application process memory includes instance memory attached at connection. Additionally, it includes process basis sharing ODBC environment, several ODBC handles, heap memory area with bind information.

## Startup and Shutdown Instance

To startup the GOLDILOCKS instance, set the SHARED\_MEMORY\_STATIC\_KEY property differently from other instances. After that, a user can startup the GOLDILOCKS instance by using gsql. Execute it to take sysdba role as follows.

A user should run **listener** before startup or shutdown the GOLDILOCKS instance in dedicated mode of C/S model.

A user can not startup or shutdown the GOLDILOCKS instance in shared mode of C/S model.

```
% gsql sys gliese --as sysdba
Connected to GOLDILOCKS Database.
gSQL>
```

Startup phrase in the GOLDILOCKS instance has several phases as follows.

- NOMOUNT
  - It starts up gmaster process which is a managing daemon of the GOLDILOCKS instance.
- MOUNT
  - It loads properties and recovery control file by using \$GOLDILOCKS \_DATA environment variable.
- OPEN
  - After loading the tablespace contents from data file, it recovers by using redo log, rebuilds no-logging indexes, creates dictionary cache, and then waits for the user's service connection.

A user can start up the GOLDILOCKS instance by using gsql as follows.

```
gSQL> \startup nomount
Startup success
gSQL> alter system mount database;
System altered.
gSQL> alter system open database;
System altered.
```

To directly enter into OPEN phase, do as follows.

```
gSQL> \startup open
Startup success
```

If GOLDILOCKS instance is shut down, gmaster (the daemon process for management) would be terminated. Then, connection and database operation is no longer possible.

There are four ways to shutdown the GOLDILOCKS instance as follows.

- NORMAL
  - After blocking the access of a new session and waiting until the end of all connected sessions, a user perform a checkpoint and shuts down the instance.
- TRANSACTIONAL
  - After blocking the start of a new transaction and waiting until the end of all running transactions, a user performs a checkpoint and shuts down the instance.
- IMMEDIATE
  - After blocking the execution of a new unit operation (Connection unit with GOLDILOCKS database. e.g. FETCH or EXECUTE, etc.) and waiting until the end of all unit operations, a user rolls back all transactions, performs a checkpoint and shuts down the instance.



- ABORT
  - Regardless of any connected session's status, a user terminates gmaster and shuts down the instance.

To shutdown an instance, use gsql with sysdba role and perform \shutdown, as follows.

```
% gsql sys gliese --as sysdba
Connected to GOLDILOCKS Database.
gSQL> \shutdown normal
Shutdown success
gSQL>
```

## Start and End of Listener

A user should run the listener to provide the service in the client/ server environment.

A user can start the listener as follows.

```
% glsnr --start

Listener is started successfully.
%
```

A user can end the listener as follows.

```
% glsnr --stop

Listener is stopped.
%
```

For more information about listener control, refer to **glsnr**.

For more information about how to start or end cluster system refer to **Start and End of Cluster System**.

## 2.2 Installing GOLDBLOCKS and Creating Database

This chapter describes how to install the GOLDBLOCKS software and create a database.

### Overview

GOLDBLOCKS software is a compressed file with the name such as *goldilocks-⟨version\_no⟩-⟨os\_type⟩-⟨cpu\_type⟩.tar.gz*. After decompressing the file, software binaries, various samples, fundamental database directory structures are created at the corresponding location, and then installation is completed. After the installation, the directory is created, and the directory is named after the package. Then directories whose names are *goldilocks\_home* and *goldilocks\_data* are created under it.

- *goldilocks\_home* directory
  - Binary home of GOLDBLOCKS product
  - Defined as GOLDBLOCKS\_HOME environment variable
  - Operation binaries, libraries for the client, header files, licenses, etc. are located.
- *goldilocks\_data* directory
  - Home of the user database (instance) which GOLDBLOCKS creates.
  - Defined as GOLDBLOCKS\_DATA environment variable
  - A default location which has data files, log files, property files

After that, use a utility called *gcreatedb* in *\$GOLDBLOCKS\_HOME/bin* directory to create a database in *\$GOLDBLOCKS\_DATA* directory.

### Release Platform

GOLDBLOCKS is available in the following release platform.

**Table 2-3** Release platform

Platform	Platform name	OS	CPU	Remarks
Server platform	linux-x86_64	linux	x86_64	>= linux kernel 2.6 >= glibc 2.1[1] >= gcc 4.1.2 >= java 1.6 <= java 1.8
				>= linux kernel 2.6 >= glibc 2.1[1]

Platform	Platform name	OS	CPU	Remarks
	linux-powerpc-64	linux	powerpc	>= gcc 4.1.2 >= java 1.6 <= java 1.8
	hpux11.31-itanium-64	HP-UX 11.31	itanium	>= java 1.6 <= java 1.8
	aix7-powerpc-64	AIX 6.1	powerpc	>= java 1.6 <= java 1.8
Client platform	linux-x86_64	linux	x86_64	>= linux kernel 2.6 >= glibc 2.1[1] >= gcc 4.1.2 >= java 1.6 <= java 1.8
	linux-x86_32	linux	x86_32	>= Linux kernel 2.6 >= glibc 2.1[1] >= gcc 4.1.2 >= java 1.6 <= java 1.8
	hpux11.31-itanium-64	HP-UX 11.31	itanium	>= java 1.6 <= java 1.8
	hpux11.31-itanium-32	HP-UX 11.31	itanium	>= java 1.6 <= java 1.8
	aix7-powerpc-64	AIX 7.2	powerpc	>= java 1.6 <= java 1.8
	linux-powerpc-64	linux	powerpc	>= Linux kernel 2.6 >= glibc 2.1[1] >= gcc 4.1.2 >= java 1.6 <= java 1.8
	windows-x86-64	Windows	PENTINUM x86	>= java 1.6 <= java 1.8
	windows-x86-32	Windows	PENTINUM x86	>= java 1.6 <= java 1.8

[1]The user should install libnsl separately in CentOS 8, RHEL 8 or higher.

## System Requirements

Check the following requirements before installing GOLDILOCKS.

- At least 2 G should be secured at the physical memory and disk space.

- A sufficient amount of paging (swap) area is required.
- The correct package version which fits into the platform to be installed is required.

## GOLDILOCKS Package Configuration

This chapter describes the directory configuration when installing GOLDILOCKS.

### Package Directory Configuration

**Table 2-4** Parent directory configuration

Directory	Server	Client	Description
GOLDILOCKS_HOME	O	O	Binaries and libraries are installed, overwriting-enabled group when updating
GOLDILOCKS_DATA	O	X	The data storing path, overwriting-unabled group

**Table 2-5** Package directory configuration

Parent directory	Package directory	Description
GOLDILOCKS_HOME	admin	Required schema script to create database
	bin	Execution files
	lib	Library files
	include	Header files such as ODBC, XA, Embedded SQL, etc.
	license	License files
	sample	Sample files
	msg	Error message files
	script	Script file for ease of use (It will be supported in future)
	app_dev	Application development
GOLDILOCKS_DATA	conf	Configuration files
	db	Database files
	wal	Log files, control files
	archive_log	Archive log files
	backup	Back up files
	trc	Trace log files, warning message files
	journal	Journal file used at cluster rebalance

## Package File List

The followings are description of files in a directory, and whether it is included in server package or client package.

**Table 2-6** admin directory

File name	Server	Client	Description
README	O	X	Read me
DictionarySchema.sql	O	X	Dictionary schema creating script
InformationSchema.sql	O	X	Information schema creating script
PerformanceViewSchema.sql	O	X	Performanceview schema creating script

**Table 2-7** admin/ cluster directory

File name	Server	Client	Description
README	O	X	read me
DictionarySchema.sql	O	X	Dictionary schema creating script
InformationSchema.sql	O	X	Information schema creating script
PerformanceViewSchema.sql	O	X	Performanceview schema creating script

The script created in admin/standalone directory is used when using GOLDILOCKS in standalone. On the other hand, the script created in admin/cluster directory is used when using GOLDILOCKS by configuring cluster system.

**Table 2-8** bin directory (Unix)

File name	Server	Client	Description
README	O	O	Read me
gmaster	O	X	GOLDILOCKS master
gcreatedb	O	X	Database creating tool
glsnr	O	X	Listener control tool
gbalancer	O	X	Loads balancer for C/S shared
gdispatcher	O	X	Manages multiple connections for C/S shared
gserver	O	X	Instance manager for C/S
gsql	O	X	Interactive SQL tool
gsqlnet	O	O	Interactive SQL tool for C/S
gpec	O	O	Embedded SQL precompiler
logmirror	O	X	Redo log replication tool
cyclone	O	X	CDC replication tool
gloader	O	X	Import/ export tool
gloadernet	O	O	Import/ export tool for C/S
cymon	O	X	CDC monitoring Tool
gdump	O	X	Control/ log/ data/ binary property file viewer

File name	Server	Client	Description
gsyncher	O	X	Synchronization utility for shared memory log and disk log files
tablediff.jar	O	X	Table comparison tool
cdispatcher	O	X	Manages cluster connections and distributes protocols in cluster system
cserver	O	X	Instance manager for cluster system
gtrclogger	O	X	Trace log manager for cluster system
gmon	O	X	Process monitoring tool
galocator	O	X	Location management tool
gagent	O	X	Location provider tool
gloctl	O	O	Interactive location editing tool
cyfile	O	X	CDC exporting file tool

Table 2-9 bin directory (Windows client)

File name	Server	Client	Description
README	X	O	read me
gloadernet.exe	X	O	Import/export tool for C/S
gpec.exe	X	O	Embedded SQL precompiler
gsqlnet.exe	X	O	Interactive SQL tool for C/S
gloctl.exe	X	O	-

Table 2-10 lib directory (Unix)

File name	Server	Client (64 bit)	Client (32 bit)	Description
README	O	O	O	Read me
libstib.so	O	X	X	Shared library for infiniband
libgoldilocks.a	O	X	X	D/A and C/S-inclusive static library for ODBC
libgoldilocks.a	O	X	X	D/A-only static library for ODBC
libgoldilocksas.so	O	X	X	D/A-only shared library for ODBC
libgoldilocksc.a	O	O	O	C/S-only static library for ODBC
libgoldilockscs-ul32.so	O	O	X	64 bit-C/S-only shared library for ODBC (SQLLEN = 4 byte)
libgoldilockscs-ul64.so	O	O	X	64 bit-C/S-only shared library for ODBC (SQLLEN = 8 byte)
libgoldilockscs.so	X	X	O	32 bit-C/S-only shared library for ODBC
libgoldilockscvtGB18030_32.so	X	X	O	32 bit GB18030 character set conversion library
libgoldilockscvtGB18030_64.so	O	O	X	64 bit GB18030 character set conversion library
libgoldilockscvtUHC_32.so	X	X	O	32 bit UHC character set conversion library
libgoldilockscvtUHC_64.so				

File name	Server	Client (64 bit)	Client (32 bit)	Description
o	O	O	X	64 bit UHC character set conversion library
libgoldilocksesql.a	O	O	O	Static library for embedded SQL
libgoldilocksesqls.so	O	O	O	Shared library for embedded SQL
libgoldilockss.so	O	X	X	D/A and C/S-inclusive shared library for ODBC
goldilocks6.jar	O	O	O	C/S-only JDBC library (java 1.6)
goldilocks7.jar	O	O	O	C/S-only JDBC library (java 1.7)
goldilocks8.jar	O	O	O	C/S-only JDBC library (java 1.8)
libgoldilocksjni.so	O	X	X	D/A-only JDBC shared library
libgoldilocksjnigc.so	O	O	O	JDBC shared library for global connection
libgdlc.a	O	O	O	C/S-only static library for ODBC
libgdlcs.so	O	O	O	C/S-only shared library for ODBC

Table 2-11 lib directory (Windows client)

File name	Server	Client (64 bit)	Client (32 bit)	Description
goldilocksc.lib	X	O	O	C/S-only static library for ODBC
goldilockscs.dll	X	X	O	32 bit-C/S-only shared library for ODBC
goldilockscs-ul64.dll	X	O	X	64 bit-C/S-only shared library for ODBC (SQLLEN = 8byte)
goldilockssetup32.dll	X	X	O	32 bit setup library for ODBC
goldilockssetup64.dll	X	O	X	64 bit setup library for ODBC
goldilocksesql.lib	X	O	O	Static library for embedded SQL
goldilocksesqls.dll	X	O	O	Shared library for embedded SQL
goldilockscvtGB18030_32.dll	X	X	O	32 bit GB18030 character set conversion library
goldilockscvtGB18030_64.dll	X	O	X	64 bit GB18030 character set conversion library
goldilockscvtUHC_32.dll	X	X	O	32 bit UHC character set conversion library
goldilockscvtUHC_64.dll	X	O	X	64 bit UHC18030 character set conversion library
goldilocks6.jar	X	O	O	C/S-only JDBC library (for java 1.6)
goldilocks7.jar	X	O	O	C/S-only JDBC library (for java 1.7)
goldilocks8.jar	X	O	O	C/S-only JDBC library (for java 1.8)
gdlc.lib	X	O	O	C/S-only static library for ODBC
gdlcs.lib	X	O	O	C/S-only shared library for ODBC
gdlcs.dll	X	O	O	C/S-only shared library for ODBC
README	X	O	O	read me
goldilocksjnigc.dll	X	O	O	GOLDILOCKS application development library (JDBC D/

File name	Server	Client (64 bit)	Client (32 bit)	Description
				A mode)

**Table 2-12** include directory (Unix)

File name	Server	Client	Description
README	O	O	Read me
sql.h	O	O	ODBC header file
sqlca.h	O	O	ODBC header file
sqlext.h	O	O	ODBC header file
sqltypes.h	O	O	ODBC header file
sqlucode.h	O	O	ODBC header file
goldilocks.h	O	O	Header file for GOLDILOCKS ODBC application development
goldilockstypes.h	O	O	GOLDILOCKS ODBC data type specification file
xa.h	O	O	Standard XA header file
goldilocksxa.h	O	O	GOLDILOCKS XA header file
goldilocksesql.h	O	O	Embedded SQL header file

**Table 2-13** include directory (Windows client)

File name	Server	Client	Description
README	X	O	Read me
goldilocks.h	X	O	Header file for GOLDILOCKS ODBC application development
goldilockstypes.h	X	O	GOLDILOCKS ODBC data type specification file
goldilocksxa.h	X	O	GOLDILOCKS XA header file
goldilocksesql.h	X	O	Embedded SQL header file
sqlca.h	X	O	ODBC header file

**Table 2-14** license directory

File name	Server	Client	Description
README	O	X	Read me

**Table 2-15** msg directory

File name	Server	Client	Description
README	O	O	Read me
goldilocks_error.msg	O	O	Error message file

**Table 2-16** conf directory

File name	Description
README	Read me



File name	Description
goldilocks.property.conf	Database operation property text file
goldilocks.listener.conf	Listener property file
goldilocks.invited.conf	Client management file for database connection invited
goldilocks.excluded.conf	Client management file for database connection excluded
goldilocks.gagent.conf	gagent-only configuration file
tablediff.conf	Tablediff configuration file
cyclone.master.conf	Cyclone master only file
cyclone.slave.conf	Cyclone slave only file
logmirror.master.conf	LogMirror master only file
logmirror.slave.conf	LogMirror slave only File
odbc.ini	Template for ODBC configuration
gsqI.ini	Template for gsql configuration
glogin.sql	Execution statement list when driving gsql
goldilocks.glocator.conf	gLocator-only configuration file
cyfile.conf	cyfile-only configuration file

**Table 2-17** db directory

File name	Description
README	Read me

**Table 2-18** wal directory

File name	Description
README	Read me

**Table 2-19** archive\_log directory

File name	Description
README	Read me

**Table 2-20** backup directory

File name	Description
README	Read me

**Table 2-21** trc directory

File name	Description
README	Read me

# Installing GOLDILOCKS Software

This chapter describes the operating system and the environment setting before installing GOLDILOCKS.

## Kernel Parameters

### Shared Memory

Shared memory is a type of Inter Process Communication (IPC). It is a memory which is used for sharing data in multiple programs. GOLDILOCKS uses shared memory with user programs using gsql, gloder, ODBC for Client/ Server (C/S) environment. Because all tablespaces for operation are created in shared memory, the precise parameter setting is required.

The followings are parameters and the recommended values required for the shared memory which is used to install GOLDILOCKS.

**Table 2-22** Kernal properties for shared memory

Parameter name	Description	Recommended value	Remarks
shmmax	The maximum size of single shared memory segment	The value should be bigger than the size of the biggest datafile.	The value should be set bigger than the size of the biggest datafile belonging to the desired tablespace.
shmmni	The maximum number of shared memory segment available in system	The value should be bigger than the value of which the number of all datafile + 1.	The value should be set bigger than the value of which the number of all datafile + 1 (shared memory segment for SSA).
shmall	The total sum of all shared memory segment (The number of pages)	The value should be bigger than the total sum of tablespace configuration.	It is the total sum of pages in shared memory available in system. Generally, it is used for 8 GB or bigger shared memory. If the total sum of tablespaces in GOLDILOCKS is 32 GB, shmall should be set bigger than it.

The following is an example to set shmall when the total size of tablespaces is 32 GB.

```
kernel.shmmax = 34359738368
kernel.shmmni=4096
kernel.shmall = 8388609
```

- It is assumed that the shmmax is 32 GB and PAGE\_SIZE is 4096 bytes.

```
8388609 = (34359738368 / 4096) + 1
```

- In this case, the value of `shmmax` should be bigger than 8388609.

## Semaphore

Semaphore is a kind of IPC, like as shared memory, and it is a technology to control multiple processes' behavior using the resources from the operating system. Depending on semaphore setting, multiple processes can simultaneously refer to a relevant resource, and when any process is in use, the other process may wait until it stops using the resource.

GOLDBLOCKS uses semaphore to control the access sequence to the shared memory. For example, if multiple GOLDBLOCKS client programs request a change to the same data, it should be controlled properly. The semaphore parameter value should be set to an appropriate value according to semaphore operation of GOLDBLOCKS. A general Linux value is recommended.

The followings are recommended semaphore values to install GOLDBLOCKS.

**Table 2-23** Recommended kernel parameter value for semaphore

Kernel parameter	Description	Recommended value
<code>semmsl</code>	The number of semaphores per single semaphore set	250
<code>semmni</code>	The number of semaphore sets	128
<code>semmns</code>	The total sum of semaphore sets ( <code>semmni * semmsl</code> )	32000
<code>semopm</code>	The maximum number of semaphores per system call	100

In Linux based system such as Redhat, Ubuntu, if a user creating IPC resource logs out the session list managed by `systemd`, then the corresponding IPC resource is automatically deleted. Therefore, the system should be set as follows to prevent deleting the semaphore. (kernel 3.0.0 and higher)

```
# cp -i /etc/systemd/logind.conf /etc/systemd/logind.conf_prev
# cat /etc/systemd/logind.conf
[Login]
#NAutoVTs=6
#ReserveVT=6
...
RemoveIPC=no
```

- Modify it, then execute it.

```
# systemctl restart systemd-logind
```

## Network

The backlog means the sockets' queue length waiting to be accepted during the TCP socket listen. Set `gl_snr's backlog` in `GOLDILOCKS` as `gl_snr config file's BACKLOG`. If the backlog's maximum value in system is bigger than `somaxconn`, then it sets to `somaxconn`. In this case, `somaxconn` should be extended.

`GOLDILOCKS` uses Unix Domain Socket (UDS) queue when it operates in C/S shared mode. The queue length is set to `max_dgram_qlen`. If the value is small when clients access the network simultaneously, then it leads to bottleneck state of communication among `gl_snr`, `gbalancer` and `gdispatcher`.

The followings are recommended network values to install `GOLDILOCKS`.

**Table 2-24** Recommended kernel parameter value for network

Kernel parameter	Description	Recommended value
<code>somaxconn</code>	The maximum value of listen backlog	1024
<code>max_dgram_qlen</code>	Unix domain socket queue size	256

## Applying Parameters

For a one-time execution, a user can do as follows. (It is required to reapply when the user restarts the system).

```
[SHELL]> echo 34359738368 > /proc/sys/kernel/shmmax
[SHELL]> echo 8388608 > /proc/sys/kernel/shmall
[SHELL]> echo 4096 > /proc/sys/kernel/shmmni
[SHELL]> echo 250 32000 100 128 /proc/sys/kernel/sem
[SHELL]> echo 1024 > /proc/sys/net/core/somaxconn
[SHELL]> echo 256 > /proc/sys/net/unix/max_dgram_qlen
```

If a user wants to apply it automatically even when the user restarts the system, the user can do as follows in `/etc/sysctl.conf`.

```
# shared memory
kernel.shmmax = 34359738368
kernel.shmall = 8388608
kernel.shmmni = 4096
# semaphore
kernel.sem = 250 32000 100 128
# network
net.core.somaxconn = 1024
net.unix.max_dgram_qlen = 256
```

Use the following command to apply the changes given above.

```
[SHELL]> sysctl -p
```

## Checking Parameters

The described parameters can be checked by using the following commands.

```
[SHELL]> ipcs -l
----- Shared Memory Limits -----
max number of segments = 4096
max seg size (kbytes) = 33554432
max total shared memory (kbytes) = 33554432
min seg size (bytes) = 1
----- Semaphore Limits -----
max number of arrays = 128
max semaphores per array = 250
max semaphores system wide = 32000
max ops per semop call = 100
semaphore max value = 32767
```

## Decompressing GOLDILOCKS

GOLDILOCKS package is supplied in a compressed form. The basic installation completes by decompressing on.

The followings are simple examples of how to install the GOLDILOCKS package.

```
## $GOLDILOCKS_HOME=/home/GOLDILOCKS/goldilocks-mercury.2.1.0-linux-x86_64/
[SHELL]> gzip -d goldilocks-mercury.2.1.0-linux-x86_64.tar.gz
[SHELL]> tar -xvf goldilocks-server-mercury.2.1.0-linux-x86_64.tar
goldilocks-server-mercury.2.1.0-linux-x86_64/goldilocks_home/include/sqllex.h
goldilocks-server-mercury.2.1.0-linux-x86_64/goldilocks_home/include/goldilocks.h
goldilocks-server-mercury.2.1.0-linux-x86_64/goldilocks_home/include/sqlca.h
...
```

When the decompression completes, a user can change the directory name <package\_file\_name> on the user's taste, and accordingly the user should change the environment variables of \$GOLDILOCKS\_HOME and \$GOLDILOCKS\_DATA.

For more information about directory created by decompression, refer to **GOLDILOCKS Package Configuration**

## Setting Environment Variables

After decompression of GOLDILOCKS package, bin and lib path will be created under \$GOLDILOCKS\_HOME directory. Then as given below, a user should add bin and lib path under PATH and LD\_LIBRARY\_PATH to execute GOLDILOCKS software and develop applications. (When developing GOLDILOCKS client application, a user should always insert \$GOLDILOCKS\_HOME/include to include file directory of compile option.)

```
export PATH=$GOLDILOCKS_HOME/bin:$PATH
export LD_LIBRARY_PATH=$GOLDILOCKS_HOME/lib:$LD_LIBRARY_PATH
```

Environment variables are required to use GOLDILOCKS. A user should set them prior to installation because some variables are referenced to even during installation.

**Table 2-25** OS environment variables for GOLDILOCKS installation

Environment variables	Description	Remarks
GOLDILOCKS_HOME	Directory path to install GOLDILOCKS binaries	This variable is referenced during GOLDILOCKS operation, and the directory to install GOLDILOCKS should be set as an environment variable in advance.
GOLDILOCKS_DATA	The location to create GOLDILOCKS database instance	This variable is referenced during GOLDILOCKS database creation and operation.
PATH	Directory path of GOLDILOCKS executable file	This variable should be set to execute various GOLDILOCKS binaries without an absolute path.
LANG	Character set of terminal	<ul style="list-style-type: none"> <li>If the character set is different from the original character set which is created during GOLDILOCKS database creation, characters (Except alphabets, numbers and special characters) may not be displayed properly. Or the string related functions may not be executed correctly.</li> <li>A user should set locale corresponding to GB18030, SQL_ASCII, UHC, UTF8.</li> <li>e.g. export LANG=ko_KR.utf8</li> </ul>

```
## $GOLDILOCKS_HOME=/home/GOLDILOCKS/goldilocks-mercury.2.1.0-linux-x86_64/
[HELL]> gzip -d goldilocks-mercury.2.1.0-linux-x86_64.tar.gz
[HELL]> tar -xvf goldilocks-server-mercury.2.1.0-linux-x86_64.tar
goldilocks-server-mercury.2.1.0-linux-x86_64/goldilocks_home/include/sqlext.h
goldilocks-server-mercury.2.1.0-linux-x86_64/goldilocks_home/include/goldilocks.h
goldilocks-server-mercury.2.1.0-linux-x86_64/goldilocks_home/include/sqlca.h
...
```

## Deleting Database

Delete datafile, control file, redo log file and archive log file (when using the archive log file) should be deleted when deleting the existing database to recreate the GOLDBLOCKS DATABASE.

The following is an example of deleting GOLDBLOCKS DATABASE.

```
## $GOLDBLOCKS_BASE=/home/GOLDBLOCKS/goldilocks-mercury.2.1.0-linux-x86_64/
## $GOLDBLOCKS_DATA=/home/GOLDBLOCKS/goldilocks-mercury.2.1.0-linux-x86_64/
    goldilocks_data/
## $GOLDBLOCKS_HOME=/home/GOLDBLOCKS/goldilocks-mercury.2.1.0-linux-x86_64/
    goldilocks_home/
[HELL]> rm -rf $GOLDBLOCKS_DATA/db/*.dbf
[HELL]> rm -rf $GOLDBLOCKS_DATA/wal/*.ctl
[HELL]> rm -rf $GOLDBLOCKS_DATA/wal/*.log
[HELL]> rm -rf $GOLDBLOCKS_DATA/archive_log/*.log
```

The location of the data file and archive file may vary depending on the settings by a user.

## Deletion

GOLDBLOCKS package is not provided in compressed file format, so a specific deletion rule is not required. Delete the installed directory after terminating DATABASE.

The following is an example of deleting GOLDBLOCKS package.

```
## $GOLDBLOCKS_BASE=/home/GOLDBLOCKS/goldilocks-mercury.2.1.0-linux-x86_64/
## $GOLDBLOCKS_DATA=/home/GOLDBLOCKS/goldilocks-mercury.2.1.0-linux-x86_64/
    goldilocks_data/
## $GOLDBLOCKS_HOME=/home/GOLDBLOCKS/goldilocks-mercury.2.1.0-linux-x86_64/
    goldilocks_home/
[HELL]> rm -rf $GOLDBLOCKS_DATA
[HELL]> rm -rf $GOLDBLOCKS_HOME
[HELL]> rm -rf $GOLDBLOCKS_BASE
## ~/.bash_profile
$GOLDBLOCKS_BASE=/home/GOLDBLOCKS/goldilocks-mercury.2.1.0-linux-x86_64/ ① Delete
$GOLDBLOCKS_DATA=/home/GOLDBLOCKS/goldilocks-mercury.2.1.0-linux-x86_64/
    goldilocks_data/ ② Delete
$GOLDBLOCKS_HOME=/home/GOLDBLOCKS/goldilocks-mercury.2.1.0-linux-x86_64/
    goldilocks_home/ ③ Delete
```

## Creating Database

Create database after the completion of property creation. A user can create database by using `$GOLDILOCKS_HOME/bin/gcreatedb`. The followings are how to use the `gcreatedb` commands.

```
[SHELL]> gcreatedb --help
```

Usage

```
gcreatedb [options]
```

Options:

```
--cluster      cluster system (if not specified, stand-alone system)
--db_name      database name
--db_comment   database comment
--timezone     timezone ( {+/-}{TZH:TZM} )
--character_set character set
                SQL_ASCII
                UTF8
                UHC
                GB18030
--char_length_units char length units
                OCTETS
                CHARACTERS
--home         home directory
--member       local member name
--host         host address
--port         host port
--silent       suppresses the display of the result message
--help         print help message
```

examples:

```
gcreatedb --db_name="goldilocks" --db_comment="goldilocks database" --timezone="+09:00"
--character_set="UTF8" --char_length_units="OCTETS" --silent
```

`$GOLDILOCKS_HOME/conf/goldilocks.properties.conf` is referenced when creating database. Then, table space files are created in `SYSTEM_TABLESPACE_DIR` path in `goldilocks.properties.conf` with the value of `***_TABLESPACE_SIZE`.

--cluster option should be specified when creating the database which is to participate in cluster system.

The followings are execution arguments of `gcreatedb`.



**Table 2-26** Execution arguments of gcreatedb

Argument	Description
--cluster	It is the database to be used in cluster system. If it is omitted, standalone database is created.
--db_name	It is the database name. If it is omitted, it is set as goldilocks.
--db_comment	It is the database description. If it is omitted, it is set as goldilocks database.
--timezone	It is the timezone. If it is omitted, it is set as TIMEZONE property.
--character_set	It is the database character set. GOLDBLOCKS supports four types of character sets. <ul style="list-style-type: none"> <li>• GB18030: Simplified Chinese</li> <li>• SQL_ASCII: Character set supporting ASCII</li> <li>• UHC: Unified Hangul Code</li> <li>• UTF8: Unicode Transformation Format - 8</li> </ul> If it is omitted, it is set as CHARACTER_SET property.
--char_length_units	It is the unit of character length. <ul style="list-style-type: none"> <li>• OCTETS: It identifies 1 byte as 1 character</li> <li>• CHARACTERS: It identifies 1 character (n byte) as 1 character.</li> </ul> If it is omitted, it is set as CHAR_LENGTH_UNITS property.
--home	It is the database home directory. It searches for a property file, and is referenced to as a location of creating and storing various DB files. If it is omitted, it uses the value set in GOLDBLOCKS_DATA environment variable.
--member	It is the member name local database to be used in cluster system. If it is omitted, it uses the value set in LOCAL_CLUSTER_MEMBER property.
--host	It is the IP address of local member to be used for communication between cluster system members. If it is omitted, it uses the value set in LOCAL_CLUSTER_MEMBER_HOST property.
--port	It is the TCP listen port of local member to be used for communication between cluster system members. If it is omitted, it uses the value set in LOCAL_CLUSTER_MEMBER_PORT property.
--silent	It hides display messages.
--help	It displays help messages.

A user should consider the followings when creating database.

- Setting kernel parameter shared memory
  - If the size specified in shared memory setting is smaller than the size described in \$GOLDBLOCKS\_HOME/conf/goldilocks.properties.conf, a user can not create the database.
- Tablespace size
  - Tablespace files are created when the database is created, and the tablespace is used after being

allocated to the memory as big as the tablespace size when driving GOLDILOCKS. Therefore, it uses memory even when the actual user data does not exist in the data tablespace. Therefore, a user should create database with the sufficient memory considering the actually available memory as well as shared memory on GOLDILOCKS startup machine when writing goldilocks.properties.conf.

- Whether to use cluster system
  - It should be specified that whether the database will participate as a member of cluster system when creating the database. In other words, --cluster option should be omitted when executing gcreatedb using the database as standalone, but --cluster option should be specified when using the database as cluster system.

When database is created successfully, a user can check the following tablespace file in the path described in SYSTEM\_TABLESPACE\_DIR of goldilocks.properties.conf.

```
[SHELL]> gcreatedb
Database created
[SHELL]> gcreatedb --db_name="TEST_DB" \
                --db_comment="test database comment" \
                --timezone="+09:00" \
                --character_set="UHC" \
                --char_length_units="OCTETS"
Database created
[SHELL]> ls $GOLDILOCKS_DATA/db
system_data.dbf system_dict.dbf system_undo.dbf
```

The following is an example of creating database to be used in cluster system.

```
[SHELL]> gcreatedb --cluster
Database created
[SHELL]> gcreatedb --cluster --member=G1N1
Database created
[SHELL]> gcreatedb --cluster --member=G1N1 --host=127.0.0.1 --port 10101
Database created
[SHELL]> gcreatedb --cluster \
                --db_name="TEST_DB" \
                --home=$GOLDILOCKS_DATA \
                --host=127.0.0.1 \
                --port=10101 \
                --db_comment="g1n1 db comment" \
                --timezone="+09:00" \
                --character_set="UHC" \
                --char_length_units="OCTETS"
Database created
```

```
[SHELL]> ls $GOLDILOCKS_DATA/db
system_data.dbf  system_dict.dbf  system_trans.dbf  system_undo.dbf
```

## Building Dictionary Schema Information

Create the following schema to get the system and object information.



A user should build the following schema after database creation. Otherwise, there is a possibility of malfunction in Catalog API of ODBC, JDBC for obtaining the object's structure information (for example, SQLTables() function). If so, it will not interlock with third party tools.

- **DICTIONARY\_SCHEMA**: It consists of views and tables to get object information such as DBA\_\*, ALL\_\*, USER\_\* .
- **INFORMATION\_SCHEMA**: It consists of views and tables included in the SQL standard INFORMATION\_SCHEMA.
- **PERFORMANCE\_VIEW\_SCHEMA**: It consists of views to get system information by combining the fixed tables' information.

Views and tables included in each schemas provides convenience to get system information.

After driving GOLDILOCKS instance on OPEN phase, a user should execute the sql files as follows. It should be done at least once after the first database creation.



The scripts to build dictionary schema information are divided into the script for standalone system and the script for cluster system. Therefore, a user should use the appropriate script for the purpose to build the information.

The following describes how to build the information by using the script for standalone database.

```
% gsql --as sysdba --import $GOLDILOCKS_HOME/admin/standalone/DictionarySchema.sql
% gsql --as sysdba --import $GOLDILOCKS_HOME/admin/standalone/InformationSchema.sql
% gsql --as sysdba --import $GOLDILOCKS_HOME/admin/standalone/PerformanceViewSchema.sql
```

The following describes how to build the information by using the script for cluster system.

```
% gsql --as sysdba --import $GOLDILOCKS_HOME/admin/cluster/DictionarySchema.sql
% gsql --as sysdba --import $GOLDILOCKS_HOME/admin/cluster/InformationSchema.sql
% gsql --as sysdba --import $GOLDILOCKS_HOME/admin/cluster/PerformanceViewSchema.sql
```

## 2.3 Managing Database Memory Structure

This chapter describes the database components which compose GOLDILOCKS instance.

### Database Memory Structure

GOLDILOCKS database is divided into memory area and disk area. Memory area is a collection of tablespaces consisting of one or more shared memories. Owing to its in-memory database, GOLDILOCKS database never goes down to the disk by replace operation.

Disk area consists of data files, control file, property file, online redo log files. Data file exists one per shared memory of each tablespace, and control file contains instance configuration information, property file stores instance environment settings, and online redo log file is used to recover database.

### Control File

Control file records the physically stored information on the disk of database, and determines the status of database by firstly reading at the beginning of Instance startup. The control file records the following information.

- Instance state at the time of the previous checkpoint
- Transaction durability mode (CDS/TDS) at the time of the previous startup
- Online redo log file information
- Data file information of each tablespace

### Online Redo Log File

Online redo log files store all changes made to the database by transactions in instances. It is used to recover unwritten changes on the data file when restarting instance after database's abnormal termination. Four online redo log files are generated by default in the size specified in LOG\_FILE\_SIZE property when creating database. A user can add more if the user need. The redo log files are reused in circulation manner.

Checkpoint are generated when online redo log file switches to the next file, and then some dirty pages move down to an appropriate data file. If the checkpoint operation is delayed and the updated page does not move down (ACTIVE state), all transactions will be suspended until checkpoint completion. Therefore, creating a suitable size online redo log file according to the application's characteristic is helpful to improve the database system performance.

## Undo Segment

Undo segments records images in advance of changing operation to use when transactions partially or to tally rollback. A single undo segment is assigned to a single transaction during update operation. Undo segments are stored in MEM\_UNDO\_TBS tablespace. It is recommended to secure enough undo tablespace, in preparation for multiple update transactions or a single transaction with large amount of update operation (bulk delete).

## Data File

Data file includes the contents of tables/indexes stored in tablespace.

Data file consists of the followings.

- Page
  - The minimum unit of database I/O. The current size is 8 Kbytes.
- Extent
  - A certain number of continuous pages' collection. The minimum unit of which the segment is allocated space from the tablespace.
  - Extent size of each tablespace could be different.
- Segment
  - A specific type of data structure's collection. A segment consists of extent sets.

Exceptionally, a temporary tablespace, such as MEM\_TEMP\_TBS tablespace, does not execute redo logging, nor does data file create.

## Tablespace

Database is divided into tablespaces which is a logical structure containing tables and indexes. GOLDILOCKS tablespace is classified into the memory tablespace and the disk tablespace. In the memory tablespace, a separate disk I/O does not occur when the shared memory is created per each data file in the tablespace and accesses to the page. However, in the disk tablespace, the buffer cache of the system is used to access the page. The information about the tablespace existing in the current database can be output by retrieving V\$TABLESPACE table.

GOLDILOCKS supports the following tablespaces by default.

**Table 2-27** Tablespaces of GOLDILOCKS

Owner	Name	Description
	DICTIONARY_TBS	Default dictionary tables are stored in this tablespace to operate database.
	MEM_UNDO_TBS	Undo segments and transaction information are stored in this table space.
	MEM_DATA_TBS	If a user does not specify a tablespace when creating schema object, the data table is stored in this tablespace by default.

Owner	Name	Description
SYSTEM	DISK_DATA_TBS	It is the disk tablespace which the user uses by default.
	MEM_TEMP_TBS	Indexes which does not specified tablespace name, and temporary tables which are used by queries are created in the tablespace. Indexes are rebuilt when restarting instance because logging does not occur.
	MEM_TRANS_TBS	It is used to recover global transaction in cluster system. It is created only when it is configured as cluster system.
USER	User-defined	User defines this tablespace to collect specific tables to a specific tablespace and manage them.

## Tablespace Types

There are five types of tablespace as follows.

- DICT
  - Tablespace type for storing dictionary tables and indexes.
- DATA
  - Tablespace type for storing general schema objects such as tables and indexes.
  - It becomes the subject of redo logging and page flushing.
- UNDO
  - Tablespace type for storing undo segments.
  - It becomes the subject of redo logging and page flushing.
- TEMPORARY
  - Tablespace type for storing the temporary tables and no-logging indexes which are created during SELECT query.
  - It is not the subject of redo logging and page flushing.
- TRANSACTION (Cluster only)
  - Tablespace type which is used to recover global transaction in cluster system

## Checking Information of Database Storage Structure

This chapter describes a method to check the information about multiple database storage structure which are mentioned above.

### Control File Information

Use `gdump` utility to check the contents because control file is stored in binary format.

```
[SHELL]> gdump CONTROL control_0.ctl
```

## Online Redo Log File Information

Retrieve the control file by using gdump tool, then the name and current state of each online redo file will be displayed.

## Data File Information

Retrieve the control file by using gdump tool, then the data files in each tablespaces and its states will be displayed. Also, viewing the V\$DATAFILE table, their current states will be displayed.

## Tablespace Information

Retrieve the control file by using gdump tool, then the name and state of each tablespace in the current database will be displayed. Also, a user can enquire the V\$TABLESPACE table by using SQL.

## Property Information

Open the text file \$GOLDILOCKS\_Data/conf/goldilocks.properties.conf, then the property information will be displayed. When working online, retrieve V\$PROPERTY table, then the information about currently applied property values will be displayed.

## General Operation of Data Storage

A tablespace stores data, and its operation is as follows.

### Creating Tablespace

The memory and the disk USER DATA tablespaces are created as follows.

```
gSQL> CREATE TABLESPACE TEST_TBS DATAFILE 'TEST_TBS.dbf' SIZE 10M;
Tablespace created.
gSQL> CREATE MEMORY TABLESPACE TEST_TBS DATAFILE 'TEST_MEM_TBS.dbf' SIZE 10M;
Tablespace created.
gSQL> CREATE DISK TABLESPACE TEST_TBS DATAFILE 'TEST_DISK_TBS.dbf' SIZE 10M;
Tablespace altered.
gSQL> CREATE DISK TABLESPACE DISK_TBS DATAFILE 'TEST_DISK_TBS.dbf' SIZE 10M AUTOEXTEND OFF;
Tablespace altered.
```

TEMPORARY tablespace does not include data file, so it is created as follows.

```
gSQL> CREATE TEMPORARY TABLESPACE TEST_TEMP_TBS MEMORY 'TEST_TEMP_TBS' SIZE 10M;
Tablespace created.
```

## Retrieving Tablespace Usage State

A tablespace's space is allocated or deallocated in the unit of one extent consisting of one or more consecutive pages. A user can retrieve the size of one extent (BYTE) in a specific tablespace as follows.

```
gSQL> SELECT EXTENT_SIZE FROM V$TABLESPACE WHERE TBS_NAME = 'TEST_TBS';
EXTENT_SIZE
-----
          262144
1 row selected.
```

A user can view the state of all extents in tablespaces by using D\$TABLESPACE\_EXTENT table. When an extent is in use, the STATE column is 'U'. When an extent is in free state, the STATE column is 'F'. Therefore, the remaining size of space in the current tablespace (the number of extents) can be calculated as follows.

```
gSQL> SELECT COUNT(*) FROM D$TABLESPACE_EXTENT('TEST_TBS') WHERE STATE = 'F';
COUNT(*)
-----
          38
1 row selected.
```

Seeing the result above, the empty space in TEST\_TBS is  $38 * 262144 = 9437184$  Byte.

## Altering Tablespace

A user can alter the tablespaces by using Add/Remove Data File (Memory in case of temporary tablespaces), and Online/Offline.

### Add/ Drop Data File (or Memory)

If a user wants to add spaces to tablespaces while operating the database, the DATA tablespaces allocate the additional space by using the following syntax.

```
gSQL> ALTER TABLESPACE TEST_TBS ADD DATAFILE 'TEST_TBS2.dbf' SIZE 10M;
Tablespace altered.
```

TEMPORARY tablespace adds spaces as follows. Unlike DATA tablespace, a name should be given, and the name should be a unique memory name in database.



```
gSQL> ALTER TABLESPACE TEST_TEMP_TBS ADD MEMORY 'TEST_TEMP_TBS2' SIZE 10M;  
Tablespace altered.
```

A user can drop the space in DATA tablespace by using the following syntax. However, if any part of the area is used, the user can not drop it.

```
gSQL> ALTER TABLESPACE TEST_TBS DROP DATAFILE 'TEST_TBS2.dbf';  
Tablespace altered.
```

Similarly, a user can withdraw the space in TEMPORARY tablespace by using the following syntax.

```
gSQL> ALTER TABLESPACE TEST_TEMP_TBS DROP MEMORY 'TEST_TEMP_TBS2';  
Tablespace altered.
```

## Offline Tablespace

Switch the tablespace to offline mode if a user wants to move the location of data file in the tablespace. Use the following syntax.

```
gSQL> ALTER TABLESPACE TEST_TBS OFFLINE;  
Tablespace altered.
```

A user can switch the tablespace to online mode again by using the following syntax.

```
gSQL> ALTER TABLESPACE TEST_TBS ONLINE;  
Tablespace altered.
```

## Altering Automatic Data File Expand Property in Disk Tablespace

The data file in the disk tablespace is created in the initial size, and it is automatically extended to the maximum size when it is needed. The automatic expand property can be on or off as follows. The automatic expand size and the maximum size of the data file can be altered when altering the automatic expand property.

```
gSQL> ALTER DATABASE DATAFILE 'TEST_DISK_TBS.dbf' AUTOEXTEND ON;  
Database altered.  
gSQL> ALTER DATABASE DATAFILE 'TEST_DISK_TBS.dbf' AUTOEXTEND OFF;  
Database altered.  
gSQL> ALTER DATABASE DATAFILE 'TEST_DISK_TBS.dbf' AUTOEXTEND ON NEXT 10M MAXSIZE 20M;  
Database altered.
```

## Rename

Rename the tablespace by using the following syntax.

```
gSQL> ALTER TABLESPACE TEST_TBS RENAME TO TEST_TBS2;
Tablespace altered.
```

Switch the tablespace to offline mode, if a user wants to change the location of data file in the tablespace. Then, move the data file by using OS command, rename it by using ALTER TABLESPACE statement, then switch the tablespace to online state.

```
gSQL> ALTER TABLESPACE TEST_TBS OFFLINE;
Tablespace altered.
gSQL> ALTER TABLESPACE TEST_TBS RENAME DATAFILE 'TEST_TBS.dbf' TO 'TEST_TBS_1.dbf';
ERR-42000(16164): file does not exist :
ALTER TABLESPACE TEST_TBS RENAME DATAFILE 'TEST_TBS.dbf' TO 'TEST_TBS_1.dbf'
*
ERROR at line 1:
```

- The following procedure describes how to rename the file by using OS command.

```
gSQL> ALTER TABLESPACE TEST_TBS RENAME DATAFILE 'TEST_TBS.dbf' TO 'TEST_TBS_1.dbf';
Tablespace altered.
gSQL> ALTER TABLESPACE TEST_TBS ONLINE;
Tablespace altered.
```

## Dropping Tablespace

Drop an unnecessary tablespace by using the following syntax. The statement after INCLUDING is optional, but if the statement is given then it will delete all the content (schema object) and data file in the tablespaces.

```
gSQL> DROP TABLESPACE TEST_TBS INCLUDING CONTENTS AND DATAFILES;
Tablespace dropped.
```

## Store Mode

GOLDILOCKS uses the store mode as an instance unit to maximize performance under certain circumstance. Store mode defines which part of ACID property to give up to improve the operation performance in the transaction.

GOLDILOCKS supports two types of store modes.

- Transactional Data Store (TDS) mode
  - TDS mode is default store mode of GOLDILOCKS database.
  - Transactional Data Store (TDS) mode is general DBMS store mode. In this mode, all transactions in the instance write both undo log and redo log. Therefore, a user can rollback the transactions and recover using data file and online redo log file even when an instance is terminated abnormally, because periodical checkpoint are performed.
- Concurrent Data Store (CDS) mode
  - All running transactions in the instance write undo logs, but do not write redo logs. Therefore, the transactions can deal with all run-time errors, and can rollback. But if an instance is terminated abnormally or terminated using shutdown abort statement, all updated data would be lost. (It does not provide recover facility). It is because checkpoint action does not occur. CDS Mode controls concurrency among transactions, so it ensures normal operations of transactions even when different transactions access the same object at the same time.
  - CDC Mode is mainly used in run-time information oriented database in which query/update operations are frequently performed but does not require durability such as cache server.

Store mode is set through the property setting when a user starts up the instance. Transactions can not be executed in different store modes. The user should carefully set the store mode when the user starts up the instance because the user can not change the instance in online mode.

## 2.4 Managing Schema Object

### Schema Object

Schema object is a set of logical structure created by a user. GOLDILOCKS supports the following schema objects, which are table, index, synonym, view, sequence, constraint and stored procedure.

### Schema Object Management Privileges

Currently, GOLDILOCKS supports user and his privilege. Therefore, not all the users share all the created objects, so the privilege should be given to a user.

### Managing Table

This chapter describes table overview, methods of retrieving the table information, creating/ altering table and loading/ dropping data.

#### Table

A table is the most basic unit of storage containing user data. A table consists of columns and rows.

#### Table Type

Currently, GOLDILOCKS supports general heap table whose data saving order is irrelevant to sort order of a particular column. However, GOLDILOCKS does not support clustered table, partitioned table.

- It supports basic heap table only.
- It supports primary key/unique/not null constraint.
- It supports the datatypes as follows.
  - BOOLEAN
  - SMALLINT, INTEGER, BIGINT, REAL, DOUBLE, NUMERIC, FLOAT
  - CHAR (MAX 2000), VARCHAR (MAX 4000), BINARY, VARBINARY, LONG VARCHAR, LONG VARBINARY
  - DATE, TIME, TIMESTAMP, INTERVAL (It supports WITH/WITHOUT TIMEZONE of TIME/TIMESTAMP.)
  - It does not support BLOB type.

- The number of columns, indexes and constraints are not limited.
- A user can retrieve the entire table information using a query *SELECT \* FROM TABLES;*

If a huge number of rows are stored in a particular table, and then the table size becomes big, even bulk delete operation does not return the table's empty space to the tablespace. But TRUNCATE operation can return all existing space to the tablespace.

Table data can be stored and retrieved being distributed to multiple nodes according to the user's desiring distribution policy when using GOLDILOCKS configuring it as cluster system. For more information, refer to **Managing Table**

## Managing Index

This chapter describes index overview and creating/deleting index.

### Overview

Index is a subsidiary schema object which is linked to tables. A user can easily find the location of specifically conditioned row using the index. A user can also retrieve the row's column value if the column is the key column of the index.

GOLDILOCKS can create as many indexes in need to tables. However, too many indexes burden the execution of inserting/ changing/ deleting operation of the table, then it may lower the performance.

Primary key or unique constraint automatically creates an index on that column.

### Index Property

- It supports B-link tree form index.
  - GOLDILOCKS provides B-link tree form index by default.
- The size of a single index node is 8 Kbytes.
- The maximum number of key columns is 32, and the maximum key length is 2000 bytes.
- It supports unique index.
- It supports Ascending/Descending, NULLS FIRST and NULLS LAST.
  - A user can define whether to sort index key columns in ascending order (ASC) or in descending (DESC) order.
  - A user can define whether to list NULL value of the index key column at first (NULLS FIRST) or at last (NULLS LAST).
- A user can retrieve the whole index information by using the query *SELECT \* FROM INDEXES;*
- A user can calculate the index size in the similar way of calculating table because index is implemented by segment in the same way of implementing table.

## Sequence

Sequence is a schema object which generates a unique number.

A user can generate the sequence as follows.

```
gSQL> CREATE SEQUENCE customers_seq START WITH 1000 INCREMENT BY 1 NOCACHE NOCYCLE;  
Sequence created.
```

A user can use the sequence by using NEXTVAL.

```
gSQL> SELECT customers_seq.NEXTVAL FROM dual;
```

A user can drop the sequence as follows.

```
gSQL> DROP SEQUENCE customers_seq;
```

Global sequence object is automatically created when user creates sequence by using GOLDLOCKS configuring cluster system. This object manages the global pool of the sequence value which is used being shared by all member nodes in cluster system. Each member node is allocated the sequence value as many as specified from the global object when calling NEXTVAL and uses them.

For more information, refer to **Global Sequence**.

## 2.5 Managing User

### Creating User

Only the SYS user and the user with the CREATE USER ON DATABASE privilege can create a user for GOL DILOCKS database. The CREATE SESSION ON DATABASE privilege is required to connect to the newly created user.

The followings are the syntax to create a user.

```
<user definition> ::=
    CREATE USER user_identifier IDENTIFIED BY password
    [ DEFAULT TABLESPACE tablespace_name ]
    [ TEMPORARY TABLESPACE tablespace_name ]
```

The followings are the syntax rules and parameters to create a user.

- user\_identifier
  - It is a username to be created.
  - The username and the role name should be unique.
  - The length of a user\_identifier should be smaller than 128 bytes.
- password
  - The password is stored encrypted.
  - The length of a password should be smaller than 128 bytes.
  - Password is case-sensitive.
- DEFAULT TABLESPACE tablespace\_name
  - It specifies the default tablespace which stores the objects such as tables, indexes (LOGGING) created by a user which is to be created.
  - If DEFAULT TABLESPACE clause is omitted, it specifies as the default data tablespace (MEM\_DATA\_TBS) which is defined when creating DATABASE (<database definition>).
- TEMPORARY TABLESPACE tablespace\_name
  - It specifies the TABLESPACE to store user-created temporary tables, index (NO LOGGING), and query processing-generated intermediate results.
  - If TEMPORARY TABLESPACE clause is omitted, it is specified as the default temporary tablespace (MEM\_TEMP\_TBS) which is defined when creating DATABASE (<database definition>).
- INDEX TABLESPACE tablespace\_name
  - It specifies the default tablespaces to store an index object created by a user to be created.
  - If INDEX TABLESPACE clause is omitted, the default value is INDEX TABLESPACE NULL.

## Dropping User

It drops the created user of GOLDILOCKS database. An access privilege and user range for dropping user are as same as those for creating user.

The following is the syntax to drop a user.

```

<drop user statement> ::=
    DROP USER [ IF EXISTS ] user_identifier [ <drop behavior> ]
    ;
<drop behavior> ::=
    RESTRICT
    | CASCADE
  
```

The followings are the syntax rules and parameters for dropping a user.

- IF EXISTS
  - Even when the user does not exist, an error does not occur.
- user\_identifier
  - It is a database username to be dropped.
  - A user can not drop a user, such as SYS, which is automatically generated when the database is created.
  - It does not drop objects, such as tablespace, which is not the owner but created by user\_identifier.
- drop behavior
  - If drop behavior is omitted, the default value is RESTRICT.

## Altering User

It alters the definition of the GOLDILOCKS database user. ALTER USER privilege is required for an ordinary user. However, if a user is the user\_identifier user, then the user can alter the definition without the privilege.

The followings are the syntax to alter the user definition.

```

<alter user statement> ::=
    ALTER USER user_identifier <alter user action>
    | ALTER USER PUBLIC <alter schema path>
    ;
<alter user action> ::=
  
```



```

    <alter password>
  | <alter profile>
  | <alter default tablespace>
  | <alter temporary tablespace>
  | <alter index tablespace>
  | <alter schema path>
<alter password> ::=
    IDENTIFIED BY new_password [ REPLACE old_password ]
<alter profile> ::=
    PROFILE { profile_name | DEFAULT | NULL }
<password expire> ::=
    PASSWORD EXPIRE
<account lock> ::=
    ACCOUNT { LOCK | UNLOCK }
<alter default tablespace> ::=
    DEFAULT TABLESPACE tablespace_name
<alter temporary tablespace> ::=
    TEMPORARY TABLESPACE tablespace_name
<alter index tablespace> ::=
    INDEX TABLESPACE { tablespace_name | NULL }
<alter schema path> ::=
    SCHEMA PATH ( { schema_name | CURRENT PATH } [, ...] )

```

The followings are the syntax rule and parameters for altering user.

- user\_identifier
  - It is a username to be altered.
- <alter password>
  - It alters user password.
  - IDENTIFIED BY new\_password
    - It changes the current password, and the new password is stored encrypted.
    - The length of a password should be smaller than 128 bytes.
    - Password is case-sensitive.
  - REPLACE old\_password
    - If a user have ALTER USER ON DATABASE privilege, the user can omit it.
    - If a user do not have ALTER USER ON DATABASE privilege, the user can not omit it.
    - The user and user\_identifier should be same.
- <alter profile>
  - It alters the profile for password management policies.
  - PROFILE profile\_name
    - It allocates profile\_name created by a user.

- PROFILE DEFAULT
  - It allocates "DEFAULT" which is the default profile.
- PROFILE NULL
  - It does not allocate the profile.
- <password expire>
  - It expires the user password.
- <account lock>
  - ACCOUNT LOCK
    - It locks the user account.
  - ACCOUNT UNLOCK
    - It unlocks the account lock.
- <alter default tablespace>
  - It alters user's default tablespace.
  - tablespace\_name should be data tablespace.
- <alter temporary tablespace>
  - It alters user's temporary tablespace.
  - tablespace\_name should be temporary tablespace.
- <alter index tablespace>
  - It alters the index tablespace of a user.
  - It assigns INDEX TABLESPACE tablespace\_name
    - When assigning the data tablespace, it becomes the LOGGING index.
    - When assigning the temporary tablespace, it becomes the NOLOGGING index.
  - INDEX TABLESPACE NULL
    - It does not assign the index tablespace.

## 2.6 GOLDILOCKS Property

GOLDILOCKS property is classified as the property which is applied when creating database and the property which can be updated at online/offline. A user can change the tablespace path and the redo log file only at MOUNT phase of startup.

### Properties When Creating Database

**Table 2-28** Properties when creating database

Name	Description
SYSTEM_MEMORY_DICT_TABLESPACE_SIZE	Initial size of dictionary tablespace
SYSTEM_MEMORY_DATA_TABLESPACE_SIZE	Initial size of system data tablespace
SYSTEM_MEMORY_UNDO_TABLESPACE_SIZE	Initial size of system undo tablespace
SYSTEM_MEMORY_TEMP_TABLESPACE_SIZE	Initial size of system temporary tablespace
LOG_BLOCK_SIZE	Block size of redo log file
LOG_FILE_SIZE	Initial size of redo log file
LOG_GROUP_COUNT	The number of redo log files
CHARACTER_SET	Character set
TIMEZONE	Time zone
CHAR_LENGTH_UNITS	Character length unit

### Properties When Driving Database

There are more than 100 properties in GOLDILOCKS database. The followings are frequently used properties among them.

**Table 2-29** Frequently used properties when driving database

Name	Description
SHARED_MEMORY_STATIC_KEY	Key value to create the shared memory
SHARED_MEMORY_STATIC_SIZE	Size of the shared memory
DATA_STORE_MODE	Storage mode of GOLDILOCKS instance
LOG_BUFFER_SIZE	Log buffer size
LOG_DIR	Directory path of redo log
PRIVATE_STATIC_AREA_SIZE	Static area size per session
CLIENT_MAX_COUNT	The maximum number of accessible session
PROCESS_MAX_COUNT	The maximum number of process

Name	Description
NET_BUFFER_SIZE	Network buffer size per session

## 2.7 GOLDILOCKS Utility

### gcreatedb

The gcreatedb utility initializes GOLDILOCKS database and gets ready for the service. The gcreatedb generates data files and log files in the GOLDILOCKS\_DATA environment variable location according to given properties. The following is a syntax.

```
[SHELL]> gcreatedb --help
```

Usage

```
gcreatedb [options]
```

Options:

```
--cluster      cluster system (if not specified, stand-alone system)
--db_name      database name
--db_comment   database comment
--timezone     timezone ( {+/-}{TZH:TZM} )
--character_set character set
                SQL_ASCII
                UTF8
                UHC
                GB18030
--char_length_units char length units
                OCTETS
                CHARACTERS
--home         home directory
--member      local member name
--host        host address
--port        host port
--silent      suppresses the display of the result message
--help       print help message
```

examples:

```
gcreatedb --db_name="goldilocks" --db_comment="goldilocks database" --timezone="+09:00"
--character_set="UTF8" --char_length_units="OCTETS" --silent
```

Tablespace files are created in *SYSTEM\_TABLESPACE\_DIR* of goldilocks.properties.conf as each value of *\*\*\_TABLESPACE\_SIZE* by referring to *\$GOLDILOCKS\_HOME/conf/goldilocks.properties.conf* when creating the database.

The followings are execution arguments of gcreatedb command.

**Table 2-30** Execution arguments of `gcreatedb`

Argument	Description
<code>--cluster</code>	It is the database to be used in cluster system. If it is omitted, standalone database is created.
<code>--db_name</code>	It is the database name. If it is omitted, it is set as <i>goldilocks</i> .
<code>--db_comment</code>	It is the database description. If it is omitted, it is set as <i>goldilocks database</i> .
<code>--timezone</code>	It is the timezone. If it is omitted, it is set as TIMEZONE property.
<code>--character_set</code>	It is the database character set. GOLDILOCKS supports four types of character sets. <ul style="list-style-type: none"> <li>• GB18030: Simplified Chinese</li> <li>• SQL_ASCII: Character set supporting ASCII</li> <li>• UHC: Unified Hangul Code</li> <li>• UTF8: Unicode Transformation Format - 8</li> </ul> If it is omitted, it is set as CHARACTER_SET property.
<code>--char_length_units</code>	It is the unit of character length. <ul style="list-style-type: none"> <li>• OCTETS: It identifies 1 byte as 1 character.</li> <li>• CHARACTERS: It identifies 1 character (n byte) as 1 character.</li> </ul> If it is omitted, it is set as CHAR_LENGTH_UNITS property.
<code>--home</code>	It is the database home directory. It searches for a property file, and is referenced to as a location of creating and storing various DB files. If it is omitted, it uses the value set in GOLDILOCKS_DATA environment variable.
<code>--member</code>	It is the member name of local database to be used in cluster system. If it is omitted, it uses the value set in LOCAL_CLUSTER_MEMBER property.
<code>--host</code>	It is the IP address of local member to be used for communication between cluster system members. If it is omitted, it uses the value set in LOCAL_CLUSTER_MEMBER_HOST property.
<code>--port</code>	It is the TCP listen port of local member to be used for communication between cluster system members. If it is omitted, it uses the value set in LOCAL_CLUSTER_MEMBER_PORT property.
<code>--silent</code>	It hides display messages.
<code>--help</code>	It displays help messages.

## gsqL (GOLDILOCKS Interactive SQL Tool)

gsqL is an interactive command line utility to execute SQL statements for managing GOLDILOCKS database. DBA creates initial table schema by using gsqL, or checks the current database state.

The following is the gsql syntax.

```
[SHELL]> gsql <userid> <passwd>
gSQL> CREATE TABLE T1 ( COL1 INTEGER );
create success
gSQL> \q
[SHELL]>
```

## gloader (GOLDILOCKS Data Upload/download Tool)

The gloader utility downloads existing data in database to a file in text format, or it uploads an existing data in text format to a new database. The text data file format of gloader is Comma-Separated Value (CSV).

The following is how to use gloader.

```
gloader [export|import] userid/passwd control='control_file_name' \
data='data_file_name' log='log_file_name' bad='bad_file_name'
```

**Table 2-31** Arguments of gloader

Argument	Description
export   import	It declares whether to download the contents of existing table to data_file_name, or to upload existing data in data_file_name to a specified table in control_file_name.
userid	It specifies user ID.
passwd	It specifies the password of the userid.
control	It specifies the file path in which detailed settings are written during export/import operation.
data	It specifies target data file to export, or data file to import.
log	It specifies log file path in which the progress and the elapsed time of import/export operation.
bad	It specifies bad file path which records data records failed in insertion at importing due to various errors.

The following is an example of a control file.

```
TABLE TEST_TBL
FIELDS TERMINATED BY ','
OPTIONALLY ENCLOSED BY ''''
```





**3.**

---

## **Cluster Tutorial**

## 3.1 Managing GOLDBLOCKS Cluster System

This chapter describes the basic information for configuring and managing the cluster system by using multiple GOLDBLOCKS databases. Only the parts added to the cluster system or distinguishing the cluster system comparing to the standalone database are described in this chapter, so it is prerequisite to read the standalone database tutorial before read this chapter.

### Overview

GOLDBLOCKS can be used by configuring a standalone database as described in the previous chapter. Or, a user can also bind multiple databases into a single cluster, then select an appropriate solution for data distribution. In other words, a user can customize how to distribute massive data to multiple servers when using GOLDBLOCKS cluster system. This guarantees high availability and improves the throughput due to the parallel processing.

GOLDBLOCKS cluster system consists of one or more cluster groups, and a cluster group consists of one or more cluster members. It does not require an extra application server or a meta server. Applications are operated accessing to cluster members corresponding to the data server. Cluster members belonging to the same cluster group keeps the same data replication.

A user should determine whether to use GOLDBLOCKS database as standalone system or as cluster system, when creating database of each node. To use it as cluster system, a user should add options related to cluster when creating database of each node.

### Property Setting

Properties to build cluster system are described in `$GOLDBLOCKS_DATA/conf/goldlocks.property.conf` file of each server as like when using standalone database. Main properties for TBS (tablespace), LOG, CONTROL FILE can be set as same as setting in standalone system even when using cluster system. However, there should not be the same path or port of files among cluster members when creating multiple databases to configure cluster system in a single server.

The followings describe main property items of when configuring cluster system.

**Table 3-1** Main property items

Property	Description	Default value
	It is the directory path of installing the following system TBS.	

Property	Description	Default value
SYSTEM_TABLESPACE_DIR	<ul style="list-style-type: none"> <li>• DICTIONARY_TBS</li> <li>• MEM_DATA_TBS</li> <li>• MEM_UNDO_TBS</li> <li>• MEM_TEMP_TBS</li> <li>• MEM_TRANS_TBS</li> </ul>	'<GOLDDILOCKS_DATA>/db'
SYSTEM_MEMORY_DICT_TABLESPACE_SIZE	It is the dictionary tablespace size.	256M
SYSTEM_MEMORY_DATA_TABLESPACE_SIZE	It is the data tablespace size.	200M
SYSTEM_MEMORY_UNDO_TABLESPACE_SIZE	It is the undo tablespace size.	32M
LOG_DIR	It is the default log directory path.	'<GOLDDILOCKS_DATA>/wal'
SYSTEM_LOGGER_DIR	It is the system log directory path.	'<GOLDDILOCKS_DATA>/trc'
CONTROL_FILE_COUNT	It is the number of control files.	2
CONTROL_FILE_0	It is the first control file path.	'<GOLDDILOCKS_DATA>/wal/control_0.ctl'
CONTROL_FILE_1	It is the second control file path.	'<GOLDDILOCKS_DATA>/wal/control_1.ctl'
LOCAL_CLUSTER_MEMBER	It is the name of cluster member of which local server uses in cluster system.	'G1N1'
LOCAL_CLUSTER_MEMBER_HOST	It is the host name of local server.	'127.0.0.1'
LOCAL_CLUSTER_MEMBER_PORT	It is TCP listen port of which local server uses for the communication in cluster system.	10101

The name of cluster member and host-port combination should be unique in cluster system. To omit the property setting above, provide information by using `--member`, `--host`, `--port` options when creating data base using `gcreatedb`. The member information provided by property or `gcreatedb` option is stored and managed in `$GOLDDILOCKS_DATA/wal/location.ctl` file.

To modify the properties, update the text property file (`$GOLDDILOCKS_DATA/conf/golddilocks.properties.conf`), or define a new variable in a form of `GOLDDILOCKS_<property_name>` in an environment variable. The property file is prior to the environment variable.

## Background Process

GOLDDILOCKS cluster system has the background process (`gmaster`) to manage instances per each member node. `gmaster` of each node consists of multiple system threads internally. Most of them are as same as those in standalone system, but the following system threads are added to manage cluster system.

The following threads are performed only when starting the database created as cluster mode.

- Cluster recover thread: It recovers global transaction in cluster system.
- Failover thread: It deals with the failover through reselecting offline and coordinator for the members when an error occurs on a specific node or in a network in cluster system.

Two following processes are additionally driven when using GOLDILOCKS as cluster system.

- cdispatcher: It transmit/receive cluster packet and manages sessions.
- cserver: It performs operation of modifying and querying for the database to which the member node belongs.

GOLDILOCKS cluster system requires complex cluster protocol communication among member nodes, and cluster dispatcher (cdispatcher) is a process to efficiently perform the management of network communication context and packet distribution mechanism. In addition, it performs monitoring continuously the validity of cluster session through heartbeat.

In cluster system, SQL performing in a specific node (driver node) needs to store data on the remote member node by referring to the sharding strategy of the target table or enquires the data stored in the corresponding node. In this case, a process is required to process this request and return the result in each member node, and that process is cserver.

## Client Process

A user can use both client server (C/S) model and direct access (D/A) model in cluster system as like standalone system. However, each member node of cluster system has its own listener, so the client programs should know the listen port of the cluster member to access beforehand (in C/S mode). A user can process various transactions when accessing to any node of cluster system as like standalone database.

Signal handling, cleanup for connection, releasing shared resources in cluster system are processes as same as those in standalone system.

## Memory Structure of Instance

GOLDILOCKS cluster system is used to bind multiple shared-nothing databases to a management unit which is a single cluster system. Therefore, a method of using memory of cluster member nodes is similar to that of standalone. The memory size of which each member node uses are determined by properties set in its own property. Static area contains instance basic information for database management, information for each session, statement, transaction, redo log buffer, dictionary cache, and other operational information as like standalone system. Additionally, information for management of cluster session such as inf

ormation for location and cluster session are also stored.

Tablespace area consists of page frames and page control header (PCH). The page frame contains the contents of each tablespace and PCH controls those page frames.

The application process memory contains instance memories attached when connecting, ODBC environment shared in process unit, various ODBC handles and heap memory area containing other information such as bind information.

## Start and End of Cluster System

To start GOLDILOCKS system, create instance on each member node beforehand (gcreatedb), and then register cluster group and cluster member. Later, a user can start or end the system by using sysdba role through gsql and gsqlnet.

**listener** should be in operation if a user wants to start or end GOLDILOCKS cluster system in dedicated mode of C/S model(to use gsqlnet).

GOLDILOCKS cluster system can not be started or ended in the shared mode of C/S model.

```
% gsql --as sysdba
Enter user-name: sys
Enter password:
Connected to an idle instance.
gSQL>
```

GOLDILOCKS cluster system has the following startup phases. OPEN phase is subdivided into LOCAL OPEN and GLOBAL OPEN unlike the standalone system.

- NOMOUNT
  - It launches gmaster which is a demon to manage GOLDILOCKS instance.
- MOUNT
  - It reads properties, and the control file for the recovery by using \$GOLDILOCKS\_DATA environment variable.
- LOCAL OPEN
  - It loads tablespace content from data files, then performs recovery by using the redo log files, and recovers in-doubt global transaction, newly build no-logging indexes, and creates dictionary caches.
- OPEN (GLOBAL OPEN)
  - It connects cluster sessions of each cluster member, arranges shard map, selects a global manager ( global coordinator) and a group manager (group coordinator), then waits for the user to access the service.

To start or end the GOLDILOCKS cluster system the cluster system environment should be configured performing the following preliminary works. If the member name, host address, port number are uniquely given when creating each member database by using `gcreatedb`, the property setting process for each node can be omitted.

- Setting property: Update property files to be used on each member node.
- Creating database: Create the database through `gcreatedb` on each member node.
- Creating cluster group and adding a member: Create a group and a member configuring cluster system.
- Driving listener: The listener on each node should be driven beforehand to use `gsqlnet`.

Use the following syntaxes to create a cluster group or a member.

- **ALTER CLUSTER GROUP name ADD MEMBER**
- **CREATE CLUSTER GROUP**

- Creating database: It is performed on each node.

```
% gcreatedb --cluster --db_name='goldilocks' --member='g1n1' \
  --host='192.168.0.11' --port 10110
% gcreatedb --cluster --db_name='goldilocks' --member='g1n2' \
  --host='192.168.0.12' --port 10120
```

- Creating a cluster group and a member: It is performed on a single node. The startup phase of the cluster member to be created or added should be GLOBAL OPEN.

```
gSQL> create cluster group g1 cluster member g1n1
      host '192.168.0.11' port 10110;
gSQL> alter cluster group g1 add cluster member g1n2
      host '192.168.0.12' port 10120;
```

If the configuration of GOLDILOCKS cluster system is completed as above, the entire cluster system can be started or ended by using the following two methods.

- Accessing to each member node to start or end nodes one by one
  - Use `\startup` and `\shutdown` commands.
- Start or end the entire member node at once in a single member node
  - Connect through `gsqlnet`, and then use `\cstartup` and `\cshutdown` commands.

The following describes the first method above which is how to access each member node then drive cluster system. `\startup` command is used to directly enter into LOCAL OPEN phase without the intermediate phase. This can be operated being subdividing into three phases, which are `\startup nomount`, `alter system mount database`, and `alter system open local database`.

Drive up to LOCAL OPEN phase on each node through \startup, and then access a single node and drive up to GLOBAL OPEN phase.

- Startup up to LOCAL OPEN: It is performed on each member node.

```
% gsql sys gliese --as sysdba
gSQL> \startup
Startup success.
```

- Startup up to OPEN: It is performed on a single node.

```
% gsql sys gliese --as sysdba
gSQL> alter system open global database;
System altered.
```

Starting up with the first method can be a burden to an operator if many nodes are included in cluster system. It is because the entire process from end of cluster system to LOCAL OPEN should be performed everytime on every member node. The following is a simple method to startup the entire member for the ease of operation.

- Startup to GLOBAL OPEN: It is performed on a single node.

```
% gsqlnet sys gliese --as sysdba
gSQL> \cstartup
Startup success.
```



- \cstartup and \cshutdown commands can be performed only in gsqlnet, and it is not supported in gsql. Also, listener should be driven beforehand on every member node to be driven.
- To build GOLDDILOCKS cluster system containing multiple members on a single physical node, home directory name, member name and the cluster port information should not be duplicated when creating each database.

When GOLDDILOCKS system ends, gmaster, the management daemon process, ends on each member node, so it does not allow any more connection or other database operations.

The followings are two ending modes of GOLDDILOCKS cluster system.

- NORMAL: It blocks an access of a new session, waits for the termination of all sessions, performs checkpoint, then unloads the instance.
- ABORT: It immediately terminates gmaster regardless of the state of connected sessions, and unloads the instance.

If \shutdown command is performed by using gsql as follows, only the connected member node is terminated.

```
% gsql sys gliese --as sysdba
Connected to GOLDILOCKS Database.
gSQL> \shutdown normal
Shutdown success
gSQL>
```

To terminate the entire member belonging to cluster system at once, use \cshutdown command of gsqlnet as follows. The normal option can be omitted.

```
% gsqlnet sys gliese --as sysdba
Connected to GOLDILOCKS Database.
gSQL> \cshutdown normal
Shutdown success
gSQL>
```



Using abort option when performing \cshutdown, it terminates the entire member node by force. Therefore, some member nodes may fail to join cluster system when restarting it by using \cstartup. Although the failed nodes can join through the following join commands and rebalance process, it is recommended to terminate it by using \cshutdown normal which is a safe method.

To terminate and start a member node or some member nodes belonging to cluster system, follow the process below. The following describes how to restart only the G1N2 node among cluster member nodes then make it join cluster system.

```
% gsql sys gliese --as sysdba --dsn=g1n2
Connected to GOLDILOCKS Database.
gSQL> \shutdown normal
Shutdown success
gSQL> \startup
Startup success
gSQL> alter system join database;
System altered.
```

To restart a member node and make it rejoin cluster system, rebalancing operation for the altered table may be required if the corresponding node is terminated when a transaction occurs. If the rebalancing operation is not performed, the transaction performing on a driver node may fail to alter the table on which the rebalancing is not performed.



A rebalancing operation is a process which synchronizes data distribution policy and property information of table among member nodes, and dividedly stores table data again in each member nodes according to the data distribution policy.

```
% gsql sys gliese --as sysdba
Connected to GOLDILOCKS Database.
gSQL> \shutdown normal
Shutdown success
gSQL> \startup
Startup success
gSQL> alter system join database;
ERR-42000(16405): some tables in the database need to be rebalanced
System altered.
gSQL> alter database rebalance;
Database altered.
```

## 3.2 Installing GOLDBLOCKS and Creating Database

Installing and creating member database which is to be included in GOLDBLOCKS cluster system is almost as same as those in standalone system. This chapter describes only the unique feature and method used for installing and creating database of cluster system comparing to standalone system.

### Configuring GOLDBLOCKS Package

The package used to configure GOLDBLOCKS cluster system is as same as those of standalone database. However, the scripts to build dictionary and performance view are divided into the script for standalone system and the script for cluster system. Therefore, a user should use the appropriate script for the purpose to build the information after creating the database.

The script for standalone database is located below the `$GOLDBLOCKS_HOME/admin/standalone` directory and the script for cluster system is located below the `$GOLDBLOCKS_HOME/admin/cluster` directory.

**Table 3-2** admin/ standalone directory

File name	Description
README	Read me
DictionarySchema.sql	It is the dictionary schema creation script.
InformationSchema.sql	It is the information schema creation script.
PerformanceViewSchema.sql	It is the PerformanceView schema creation script.

**Table 3-3** admin/ cluster directory

File name	Description
README	Read me
DictionarySchema.sql	It is the dictionary schema creation script.
InformationSchema.sql	It is the information schema creation script.
PerformanceViewSchema.sql	It is the PerformanceView schema creation script.

### Installing GOLDBLOCKS Software

GOLDBLOCKS software should be installed on every member node belonging to cluster system, and the installing method is as same as that of standalone system. The method for setting and checking kernel parameter, setting environment variable are as same as those of standalone system, so refer to the corresponding tutorial.

In this case, be cautious that setting properties for each cluster member node, database name, database version, character set, time zone should be same for the normal operation of cluster system.

## Creating Database

Use gcreatedb utility to create database on each member node configuring cluster system as like standalone system.

The following options of gcreatedb are used only when creating cluster database. Other options are same as standalone system.

**Table 3-4** Execution arguments of gcreatedb

Argument	Description
--cluster	It represents that it is cluster database. When it is omitted, standalone database is created.
--member	The member name of local database to be used in cluster system. When it is omitted, it uses the value set in LOCAL_CLUSTER_MEMBER property.
--host	IP address of local member to be used for communication between cluster system members. If it is omitted, it uses the value set in LOCAL_CLUSTER_MEMBER_HOST property.
--port	TCP listen port of local member to be used for communication between cluster system members If it is omitted, it uses the value set in LOCAL_CLUSTER_MEMBER_PORT property.

The following is an example of creating database to be used in cluster system.

```
[SHELL]> gcreatedb --cluster
Database created
[SHELL]> gcreatedb --cluster --member=G1N1
Database created
[SHELL]> gcreatedb --cluster --member=G1N1 --host=127.0.0.1 --port 10101
Database created
[SHELL]> gcreatedb --cluster \
--db_name="TEST_DB" \
--home=$GOLDILOCKS_DATA \
--host=127.0.0.1 \
--port=10101 \
--db_comment="g1n1 db comment" \
--timezone="+09:00" \
--character_set="UHC" \
--char_length_units="OCTETS"
```

```
Database created
```

```
[SHELL]> ls $GOLDILOCKS_DATA/db
system_data.dbf  system_dict.dbf  system_trans.dbf  system_undo.dbf
```

## Building Dictionary Schema Information

To normally use cluster system, the dictionary schema information should be built as like standalone system. If the following schema is not built, the catalog API (e.g. SQLTables() function) of ODBC, JDBC obtaining object's structure information malfunctions, then it can not interwork with the third party tools. In conclusion, it should be built after creating database.

It is recommended to build schema in cluster system after completing the operation of creating a cluster group and a member. It is because GOLDILOCKS automatically creates schema on every member node when performing creation script by connecting to a member node after completing cluster system configuration.

- **DICTIONARY\_SCHEMA**: It consists of tables and views inquiring object information such as DBA\_\*, ALL\_\*, USER\_\*.
- **INFORMATION\_SCHEMA**: It consists of tables and views included in the SQL standard INFORMATION\_SCHEMA.
- **PERFORMANCE\_VIEW\_SCHEMA**: It consists of views inquiring system information combining information of fixed tables.

The followings describe how to build schema by using the script for cluster system. Perform the operation by accessing to a single member node in GLOBAL OPEN phase as described above.

```
% gsql sys gliese --as sysdba --import $GOLDILOCKS_HOME/admin/cluster/DictionarySchema.sql
% gsql sys gliese --as sysdba --import $GOLDILOCKS_HOME/admin/cluster/InformationSchema.sql
% gsql sys gliese --as sysdba --import
$GOLDILOCKS_HOME/admin/cluster/PerformanceViewSchema.sql
```

Various structure information can be viewed by using the schema information built above. What is different from standalone system is that a user can extract only the desired node information by giving group name and member node after the object when inquiring the information.

```
% gsql test test
Connected to GOLDILOCKS Database.
gSQL> select origin_member_name, stat_name, stat_value
2   from gv$system_mem_stat
3  where stat_name = 'PLAN_CACHE_TOTAL_SIZE';
ORIGIN_MEMBER_NAME  STAT_NAME          STAT_VALUE
```

```

-----
G1N1          PLAN_CACHE_TOTAL_SIZE  17844952
G2N2          PLAN_CACHE_TOTAL_SIZE  16796288
G2N1          PLAN_CACHE_TOTAL_SIZE  16796288
G1N2          PLAN_CACHE_TOTAL_SIZE  16796288
G3N1          PLAN_CACHE_TOTAL_SIZE  16796288
G3N2          PLAN_CACHE_TOTAL_SIZE  16796288

```

6 rows selected.

```

gSQL> select origin_member_name, stat_name, stat_value
      2   from gv$system_mem_stat@g1n2
      3   where stat_name = 'PLAN_CACHE_TOTAL_SIZE';

```

```

ORIGIN_MEMBER_NAME  STAT_NAME          STAT_VALUE
-----
G1N2                PLAN_CACHE_TOTAL_SIZE  16796288

```

1 row selected.

```

gSQL> select origin_member_name, stat_name, stat_value
      2   from gv$system_mem_stat@g1
      3   where stat_name = 'PLAN_CACHE_TOTAL_SIZE';

```

```

ORIGIN_MEMBER_NAME  STAT_NAME          STAT_VALUE
-----
G1N1                PLAN_CACHE_TOTAL_SIZE  17844952
G1N2                PLAN_CACHE_TOTAL_SIZE  16796288

```

2 row selected.

## 3.3 Managing Schema Object

The schema object is a logical structure created by a user. GOLDDILOCKS cluster system supports the schema objects such as table, index and global sequence. This chapter describes features of each schema object in cluster system comparing to standalone system. How to efficiently manage them is also described.

### Managing Table

A user can specify one of four following sharding strategies as an option when creating a table in GOLDDILOCKS cluster system. Sharding strategy is how to distribute and store table data to each cluster group in cluster system. This option can be specified only in cluster system, and it can not be used when database is created as standalone.

- Cloned strategy
  - It equally copies entire table data.
- Hash sharding strategy
  - It distributes table data based on the hash value of sharding key.
- Range sharding strategy
  - It distributes table data based on the range value of sharding key.
- List sharding strategy
  - It distributes table data based on the list value of sharding key.

For more information about creating table, refer to **CREATE TABLE** and **Cluster Table and Shard**.

When omitting the sharding strategy option, it is defined by **DEFAULT\_SHARDING** property. The default value of **DEFAULT\_SHARDING** is 0, and it creates cloned table.

```
CREATE TABLE t1
(
  id    INTEGER,
  name  VARCHAR(128)
);
```

If a table is created without giving the sharding strategy by as user as above, then GOLDDILOCKS cluster system internally creates a table by using the following syntax.

```
CREATE TABLE t1
(
  id    INTEGER,
```

```

name VARCHAR(128)
)
CLONED
AT CLUSTER WIDE
;

```



Hash/Range/List sharded table should comply with the followings when creating constraints.  
 - PRIMARY KEY, UNIQUE constraint should include the sharding key.

## Cloned Strategy

It does not distribute the table data based on a specific condition, but it copies all data. The target of copying data can be all nodes in cluster system, or it can be a specific cluster group. In other words, it arranges clones in cluster members of a defined cluster group.

- AT CLUSTER WIDE
  - It arranges clones in all cluster members of all cluster group in cluster system.
  - When adding a cluster group or cluster member, a user can rearranges clones by using **ALTER TABLE name REBALANCE** statement.
- AT CLUSTER GROUP group\_list
  - It arranges clones in all cluster members of a defines cluster group.
  - When adding a cluster member to a defined cluster group, a user can rearranges clones by using **ALTER TABLE name REBALANCE** statement.
  - Adding cluster group does not affect the rearrangement of clones.

When the option is omitted, the default value is automatically set to *AT CLUSTER WIDE*.

```

CREATE TABLE t1
(
  id  INTEGER,
  name VARCHAR(128)
)
CLONED
AT CLUSTER WIDE;

```

```

CREATE TABLE t1
(
  id  INTEGER,
  name VARCHAR(128)
)
CLONED

```

```
AT CLUSTER GROUP G1, G2;
```

## Hash Sharding Strategy

It distributes the table data based on the hash value of a column defined as a sharding key.

To use hash sharding strategy, sharding key should be defined complying with the following conditions.

- Up to 32 columns can be listed.
- The duplicated column can not be used.
- The column of LONG VARCHAR or LONG VARBINARY type can not be used.

```
CREATE TABLE t1 ( id INTEGER, name VARCHAR(128) )
    SHARDING BY HASH(id);
```

When hash sharding related options are omitted as above, GOLDDILOCKS system interprets it as follows.

```
CREATE TABLE t1 ( id INTEGER, name VARCHAR(128) )
    SHARDING BY HASH(id)
    SHARD COUNT 24
    AT CLUSTER WIDE;
```

Table rows are distributed to one of 24 shards based on hash value of id column, and 24 shards are equally arranged over the entire cluster system. For more information, refer to **Cluster Table and Shard**.

## Range Sharding Strategy

It distributes the table data based on the range value of the column defined as a sharding key. The shards are classified based on each range value, and they can be arranged by defining a specific group, or arranged as CLUSTER WIDE.

The following is a syntax of defining six range shards based on the range value of the sharding key column, and creating a table to distribute them as CLUSTER WIDE. If a cluster group is created after creating a table, the rearrangement of shard containing the created group can be performed by using REBALANCE feature.

- Create a range sharded table.
- Arrange six shards in existing cluster groups (g1, g2, g3).

```
CREATE TABLE t1
(
    id    INTEGER,
    name  VARCHAR(32)
```



```

)
SHARDING BY RANGE (id)
  AT CLUSTER WIDE
  SHARD s1 VALUES LESS THAN ( 200000 ),
  SHARD s2 VALUES LESS THAN ( 400000 ),
  SHARD s3 VALUES LESS THAN ( 500000 ),
  SHARD s4 VALUES LESS THAN ( 600000 ),
  SHARD s5 VALUES LESS THAN ( 800000 ),
  SHARD s6 VALUES LESS THAN ( MAXVALUE )
;

```

- Add a cluster group.

```

CREATE CLUSTER GROUP g4
  CLUSTER MEMBER g4n1 HOST '192.168.0.41' PORT 10401
;

```

- Rearrange the range shard.
- Rearrange six shards in cluster groups (g1, g2, g3, g4) in which the added group is included.

```

ALTER TABLE t1 REBALANCE;

```

The following is a syntax of defining range shards, which are defined based on the range of sharding key column value, only to be arranged in a specific cluster group. In other words, the shard s1 whose range value is smaller than 200000 is allocated in cluster group g1, s2 is allocated in cluster group g2, and shard s3 is allocated in g3. Like as shards can not be rearranged by using REBALANCE feature even when a cluster group is added later in a table created by defining cluster group.

- Create a range sharded table.
- Allocate each range shards to defined cluster groups.

```

CREATE TABLE t1
(
  id INTEGER,
  name VARCHAR(32)
)
SHARDING BY RANGE (id)
  SHARD s1 VALUES LESS THAN ( 200000 ) AT CLUSTER GROUP g1,
  SHARD s2 VALUES LESS THAN ( 400000 ) AT CLUSTER GROUP g2,
  SHARD s3 VALUES LESS THAN ( 500000 ) AT CLUSTER GROUP g3,
  SHARD s4 VALUES LESS THAN ( 600000 ) AT CLUSTER GROUP g2,
  SHARD s5 VALUES LESS THAN ( 800000 ) AT CLUSTER GROUP g3,

```

```
SHARD s6 VALUES LESS THAN ( MAXVALUE ) AT CLUSTER GROUP g1
;
```

- Add a cluster group.

```
CREATE CLUSTER GROUP g4
    CLUSTER MEMBER g4n1 HOST '192.168.0.41' PORT 10401
;
```

- Rearrange the range shard.
- A shard is not allocated to the newly created cluster group (g4).

```
ALTER TABLE t1 REBALANCE;
```

The following conditions should be considered to specify the range sharding key.

- Up to 32 columns can be listed.
- The duplicated column can not be used.
- The column of LONG VARCHAR or LONG VARBINARY type can not be used.

## List Sharding Strategy

It distributes the table data based on the list value of the column defined as a sharding key. Like as the range sharding strategy, each shard can be arranged by defining a specific group, or arranged as CLUSTER WIDE.

The followings are conditions to define the shard key in list sharding strategy.

- Only a single column can be used.
- The column of LONG VARCHAR or LONG VARBINARY type can not be used.

The following is a syntax of creating a table of which created list shards are arranged as CLUSTER WIDE. Use REBALANCE feature to rearrange shards including a cluster group created after creating a table.

- Create a list sharded table.
- Arrange five shards in existing cluster groups (g1, g2, g3).

```
CREATE TABLE city
(
    id INTEGER,
    name VARCHAR(32)
)
SHARDING BY LIST (name)
```

```

AT CLUSTER WIDE
SHARD s1 VALUES IN ( 'SEOUL' ),
SHARD s2 VALUES IN ( 'PUSAN', 'ULSAN', 'DAEGU' ),
SHARD s3 VALUES IN ( 'DAEJEON', 'GWANGJU' ),
SHARD s4 VALUES IN ( 'ANSAN', 'GOYANG' ),
SHARD s5 VALUES IN ( DEFAULT )
;

```

- Add a cluster group.

```

CREATE CLUSTER GROUP g4
    CLUSTER MEMBER g4n1 HOST '192.168.0.41' PORT 10401
;

```

- Rearrange the list shard.
- Rearrange five shards in cluster groups (g1, g2, g3, g4) in which the created group is included.

```

ALTER TABLE city REBALANCE;

```

The following is a syntax of defining list shards, which are defined based on the list value of sharding key column value, only to be arranged in a specific cluster group. Shards can not be rearranged by using REBALANCE feature even when a cluster group is created.

- Create a list sharded table.
- Allocate each range shards to defined cluster groups.

```

CREATE TABLE city
(
    id INTEGER,
    name VARCHAR(32)
)
SHARDING BY LIST (name)
    SHARD s1 VALUES IN ( 'SEOUL' ) AT CLUSTER GROUP g1,
    SHARD s2 VALUES IN ( 'PUSAN', 'ULSAN', 'DAEGU' ) AT CLUSTER GROUP g2,
    SHARD s3 VALUES IN ( 'DAEJEON', 'GWANGJU' ) AT CLUSTER GROUP g3,
    SHARD s4 VALUES IN ( 'ANSAN', 'GOYANG' ) AT CLUSTER GROUP g2,
    SHARD s5 VALUES IN ( DEFAULT ) AT CLUSTER GROUP g1
;

```

- Create a cluster group.

```
CREATE CLUSTER GROUP g4
    CLUSTER MEMBER g4n1 HOST '192.168.0.41' PORT 10401
;
```

- Rearrange the list shard.
- A shard is not allocated to the newly created cluster group (g4).

```
ALTER TABLE city REBALANCE;
```

## Managing Index

### Global Secondary Index

In cluster system, multiple member nodes exist, and table records are dividedly stored or duplicated based on the shard strategy. Standalone system guarantees the uniqueness of a record by storing unique value (Row Identifier: RID) in the database when the record is stored. However, in cluster system, each node can have the duplicated value, so the uniqueness can not be guaranteed.

Therefore, it is required to guarantee the uniqueness of a record in cluster system. This is a reason why global RID (GRID) is added. The GRID value of a record is not updated even when the record is updated, then it guarantees the uniqueness of a specific record in cluster system.

Global secondary index is a B-tree index which consists of keys to search the GRID value of the records quickly in cluster system.

A user can select whether to create global secondary index through the following properties when creating a table. The user also can delete or recreate the global secondary index after table creation is completed. Only one global secondary index can be created per table.

For more information, refer to **DEFAULT\_GLOBAL\_SECONDARY\_INDEX\_CREATION**.

A global secondary index is necessary to perform the non-deterministic query for a table. If a global secondary index does not exist in a table, then a non-deterministic query fails as follows.

```
gSQL> DELETE FROM T1 LIMIT 1;
ERR-42000(16423): does not support non-deterministic DML in the cluster system : global
secondary index expected
```

Enquire **USER\_GSI\_PLACE** DICTIONARY, or use **ALL\_GSI\_PLACE** and **DBA\_GSI\_PLACE** dictionary to check if the global secondary index of a table is created.

```

gSQL> CREATE TABLE T1( I1 INTEGER );
Table created.
gSQL> COMMIT;
Commit complete.
gSQL> SELECT *
      2 FROM USER_GSI_PLACE@LOCAL
      3 WHERE TABLE_NAME = 'T1';
TABLE_SCHEMA TABLE_NAME GROUP_ID GROUP_NAME MEMBER_ID MEMBER_NAME MEMBER_OFFLINE
-----
BLOCKS
-----
PUBLIC      T1              1 G1              1 G1N1          FALSE
      64
PUBLIC      T1              1 G1              2 G1N2          FALSE
      null
2 rows selected.
gSQL> DROP TABLE T1;
Table dropped.
gSQL> COMMIT;
Commit complete.
gSQL> SELECT *
      2 FROM USER_GSI_PLACE@LOCAL
      3 WHERE TABLE_NAME = 'T1';
no rows selected.

```

## Global Sequence

GOLDILOCKS cluster system provides global sequence object which are an expansion of the existing sequence for multiple member nodes to share and use the set of sequence value fitting into user defined conditions. In other words, the global sequence object is internally and automatically created when a user creates a sequence in cluster system, then the sequence values in a specific range are allocated and used when calling NEXTVAL on each member node. The following is a syntax of creating and using the global sequence, which are as same as those of sequence in standalone.

```

gSQL> CREATE SEQUENCE global_user_seq START WITH 1000 INCREMENT BY 1 NOCACHE NOCYCLE;
Sequence created.
gSQL> SELECT global_user_seq.NEXTVAL FROM dual;
NEXTVAL
-----

```

1

1 row selected.

gSQL&gt; DROP SEQUENCE global\_user\_seq;

Sequence dropped.

Like as the sequence used in standalone, the global sequence object can define a cache size as a creating option, and this means acquiring several sequence value from the global sequence object and loading at local cache. The followings are local cache status of each member node and return values of when calling NEXTVAL, this is when creating the global sequence object by setting cache size to 5.

gSQL&gt; CREATE SEQUENCE seq START WITH 1 CACHE 5;

Sequence created.

Member name	NEXTVAL result	The number of remaining local cache sequence		Description
		G1N1	G1N2	
G1N1	1	4	0	From Global Object (Alloc 1 ~ 5)
G1N1	2	3	0	From Local Cache
G1N1	3	2	0	From Local Cache
G1N2	6	3	4	From Global Object (Alloc 6 ~ 10)
G1N2	7	3	3	From Local Cache
G1N2	8	3	2	From Local Cache
G1N2	9	3	1	From Local Cache
G1N2	10	3	0	From Local Cache
G1N2	11	3	4	From Global Object (Alloc 11 ~ 15)
G1N2	12	3	3	From Local Cache
G1N1	4	1	3	From Local Cache
G1N1	5	0	3	From Local Cache
G1N1	16	4	3	From Global Object (Alloc 16 ~ 20)

In the table above, the sequence values are allocated to G1N1 and G1N2 two times each (four times in total) from the global sequence object. The cache option value is set to 5 when creating a sequence, so five sequence values are allocated each from the global object. Those five sequences allocated to a member node is stored in its own local cache, then it is returned one by one whenever calling NEXTVAL.

- G1N1
  - The values of five sequences (1~5) are allocated from the global sequence object when calling the first NEXTVAL.

- A single sequence is returned as a result of NEXTVAL and the values of other four sequences are loaded in its own local cache.
- NEXTVAL called later returns in turn the values of the sequences loaded in the local cache.
- G1N2
  - The values of sequences (6~10) which are after the sequences allocated on G1N1 are allocated when calling the first NEXTVAL.
  - 6 is returned as a result of NEXTVAL, and the values of other four sequences (7~10) are loaded in its own local cache.
  - NEXTVAL called later returns the sequence values loaded in the local cache.
  - Local cache is run out, so values of other five sequences (11~15) are allocated again from the global sequence object.
- G1N1
  - Local cache is run out, so the values of five sequences (16~20) after the sequences allocated last on G1N2 are allocated.

The sequence as big as the CACHE size are allocated to all member nodes when NEXTVAL has never been called on its own node or when all allocated nodes are run out. Therefore, if a system needs to acquire the sequence value quickly, it is required to set the appropriate cache size when creating a sequence to prevent too much frequent allocation. It is because, unlike standalone database, allocating sequence from the global sequence object is accompanied by the network communication cost.

The sequence values loaded in local cache can not be reused when database restarts due to a system error or operational work. The sequence values are allocated again from the global sequence object when calling NEXTVAL for the first time since the restart. Therefore, the CACHE size allocated when creating the sequence also means the range value of sequence which is possible to be lost when an error occurs, so the size should be set appropriately considering not only the corresponding feature but also loss range.

The result value of calling NEXTVAL from a specific node may not be sequential in cluster system. In the example above, the return value is not sequential when G1N1 node calls NEXTVAL. After the first allocated value(1~5) is run out, 16~20 is allocated second, so 16 is returned to a user as the next sequence value of 5. It is because a single global sequence pool is allocated competitively to multiple nodes.

The followings are features and constraints of global sequence object, comparing to the sequence for existing standalone database.

- The sign can not be modified by using INCREMENT BY option in ALTER SEQUENCE statement. (The size can be modified.)
- The duplicated value among member nodes can be returned depending on the pool size of entire sequence when using CYCLE option. Therefore, create the sequence pool big enough, considering INCREMENT BY, CACHE SIZE, and the number of cluster member nodes when CYCLE option is in need.
- The return value from a specific node may not be sequential even when an error does not occur. Of course, if only one member node calls NEXTVAL, then sequential sequence value is obtained.
- The CACHE SIZE is 1 for NOCACHE, so the additional sequence values are not loaded in local cache. In this case, only one sequence is allocated from the global sequence object whenever calling NEXTV

AL, and it increases the network cost and degrades the performance.

- Creating, updating and deleting sequences are operated as AUTO COMMIT.
- All sequence values loaded in local cache of all nodes are reset when the size of CACHE and INCREMENT are updated by ALTER statement. In other words, a new sequence set should be allocated from the global sequence object when calling NEXTVAL afterwards.



## 3.4 GOLDILOCKS Property

The followings are main properties used in GOLDILOCKS cluster system.

**Table 3-5** Main properties of GOLDILOCKS

Name	Description
LOCAL_CLUSTER_MEMBER	Member name
LOCAL_CLUSTER_MEMBER_HOST	Host address for connecting to cluster session
LOCAL_CLUSTER_MEMBER_PORT	Port for connecting to cluster session
CDISPATCHER_THREADS	The number of cluster dispatcher threads
CSERVERS	The number of cluster server process
CLUSTER_DATA_SYNC_SERVERS	The number of cluster server process to synchronize replica data

Each property has the following two alterable scopes in GOLDILOCKS cluster system.

- LOCAL: It can alter property values not only for entire member but also for a specific member only.
- GLOBAL: It can not alter the property value only for a specific member, but it should alter the property value for all members.

For example, PRIVATE\_STATIC\_AREA\_SIZE properties can be altered up to the LOCAL range (IS\_GLOBAL column = FALSE) as follows, so the property value can be altered by using *alter system set* statement not only for entire member but also for a specific member only. If AT clause is not added to after *alter system set* statement, the altered properties are applied to all members of cluster system.

```
% gsql test test
Connected to GOLDILOCKS Database.
gSQL> select origin_member_name, property_name, property_value, is_global
  2   from gv$property
  3   where property_name = 'PRIVATE_STATIC_AREA_SIZE';
ORIGIN_MEMBER_NAME  PROPERTY_NAME                PROPERTY_VALUE  IS_GLOBAL
-----
G1N1                PRIVATE_STATIC_AREA_SIZE    104857600      FALSE
G1N2                PRIVATE_STATIC_AREA_SIZE    104857600      FALSE
2 rows selected.
gSQL> alter system set private_static_area_size = 2000000000 at g1n2;
System altered.
gSQL> select origin_member_name, property_name, property_value, is_global
  2   from gv$property
  3   where property_name = 'PRIVATE_STATIC_AREA_SIZE';
ORIGIN_MEMBER_NAME  PROPERTY_NAME                PROPERTY_VALUE  IS_GLOBAL
```

```

-----
G1N1          PRIVATE_STATIC_AREA_SIZE 104857600      FALSE
G1N2          PRIVATE_STATIC_AREA_SIZE 200000000      FALSE
2 rows selected.
gSQL> alter system set private_static_area_size = 300000000;
System altered.
gSQL> select origin_member_name, property_name, property_value, is_global
       2   from gv$property
       3   where property_name = 'PRIVATE_STATIC_AREA_SIZE';
ORIGIN_MEMBER_NAME  PROPERTY_NAME          PROPERTY_VALUE  IS_GLOBAL
-----
G1N1                PRIVATE_STATIC_AREA_SIZE 300000000      FALSE
G1N2                PRIVATE_STATIC_AREA_SIZE 300000000      FALSE
2 rows selected.

```

However, `DDL_AUTOCOMMIT` can be altered up to `GLOBAL` as follows. Therefore, an error occurs when specifying a member by using `AT` clause in `alter system set` statement.

```

% gsql test test
Connected to GOLDILOCKS Database.
gSQL> select origin_member_name, property_name, property_value, is_global
       2   from gv$property
       3   where property_name = 'DDL_AUTOCOMMIT';
ORIGIN_MEMBER_NAME  PROPERTY_NAME  PROPERTY_VALUE  IS_GLOBAL
-----
G1N1                DDL_AUTOCOMMIT NO          TRUE
G1N2                DDL_AUTOCOMMIT NO          TRUE
2 rows selected.
gSQL> alter system set ddl_autocommit = false at g1n2;
ERR-42000(16398): the domain of property does not match with domain 'G1N2' :
alter system set ddl_autocommit = false at g1n2
                                *
ERROR at line 1:
gSQL> alter system set ddl_autocommit = false;
System altered.
gSQL> select origin_member_name, property_name, property_value, is_global
       2   from gv$property
       3   where property_name = 'DDL_AUTOCOMMIT';
ORIGIN_MEMBER_NAME  PROPERTY_NAME  PROPERTY_VALUE  IS_GLOBAL
-----
G1N1                DDL_AUTOCOMMIT NO          TRUE

```

G1N2	DDL_AUTOCOMMIT NO	TRUE
------	-------------------	------

2 rows selected.



**4.**

---

## **What's New**

## 4.1 Feature Matrix

This chapter briefly describes the features added to each major version.

### Architecture

#### System Architecture

The following is a feature matrix for system architecture.

**Table 4-1** Feature matrix for system architecture

Feature	2.x	3.x	20c.1	21c.1
Shared Nothing Cluster	X	O	O	O
DA (Direct Attach)	O	O	O	O
JDBC DA (Direct Attach)	X	O	O	O
C/S (Client/Server) Dedicated	O	O	O	O
C/S (Client/Server) Shared	O	O	O	O
multi-process applications	O	O	O	O
multi-threaded applications	O	O	O	O
Linux platform	O	O	O	O
HP platform	O	O	O	O
AIX platform	O	O	O	O
Windows Client Platform	O	O	O	O
CDC(Change Data Capture) replication	O	O	O	O
CDC replication with log mirror	O	O	O	O
multi-level start up	O	O	O	O
parallel database loading	O	O	O	O
parallel index build	O	O	O	O
SQL plan cache	O	O	O	O
IPC	X	X	X	O

## Storage Internal

The following is a feature matrix for storage internal.

**Table 4-2** Feature matrix for storage internal

Feature	2.x	3.x	20c.1	21c.1
memory dictionary tablespace	O	O	O	O
memory data tablespace	O	O	O	O
memory undo tablespace	O	O	O	O
memory temporary tablespace	O	O	O	O
memory bitmap data segment	O	O	O	O
memory bitmap undo segment	O	O	O	O
memory bitmap instant segment	O	O	O	O
memory heap table	O	O	O	O
memory instant table	O	O	O	O
memory B-tree index	O	O	O	O
memory instant B-tree	O	O	O	O
memory instant hash	O	O	O	O
global secondary index	X	O	O	O
disk data tablespace	X	X	O	O
disk bitmap data segment	X	X	O	O
disk B-tree index	X	X	O	O
disk global secondary index	X	X	O	O

## Transaction Control

The following is a feature matrix for transaction control.

**Table 4-3** Feature matrix for transaction control

Feature	2.x	3.x	20c.1	21c.1
CDS(Concurrency Data Store) database mode	0	0	0	0
TDS(Transactional Data Store) database mode	0	0	0	0
read-only database	0	0	0	0
read/write database	0	0	0	0
flat transaction	0	0	0	0
distributed transaction	0	0	0	0
read-only transaction	0	0	0	0
read/write transaction	0	0	0	0
READ COMMITTED isolation level	0	0	0	0
SERIALIZABLE isolation level with SELECT FOR UPDATE	0	0	0	0
MVCC(Multi Version Concurrency Control)	0	0	0	0
multi-version read consistency	0	0	0	0
multi-statement consistent read	0	0	0	0
implicit lock for DML	0	0	0	0
writer don't blocks readers	0	0	0	0
row-level locking	0	0	0	0
deadlock detection	0	0	0	0
deadlock resolution	0	0	0	0
lock granularity	0	0	0	0
read lock	0	0	0	0
write lock	0	0	0	0
intention lock	0	0	0	0
WAL(Write Ahead Logging)	0	0	0	0
repeat history	0	0	0	0
restart recovery	0	0	0	0
circular logging	0	0	0	0
buffered logging	0	0	0	0
logging group	0	0	0	0
supplemental logging	0	0	0	0
mirrored logging	0	0	0	0
synchronous commit	0	0	0	0
asynchronous commit	0	0	0	0
grouped commit	0	0	0	0
total rollback	0	0	0	0
implicit statement rollback	0	0	0	0



Feature	2.x	3.x	20c.1	21c.1
savepoint management	0	0	0	0

## Backup & Recovery

The following is a feature matrix for backup & recovery.

**Table 4-4** Feature matrix for backup & recovery

Feature	2.x	3.x	20c.1	21c.1
off-line backup	O	O	O	O
on-line backup	O	O	O	O
full backup	O	O	O	O
incremental backup	O	O	O	O
complete recovery	O	O	O	O
incomplete recovery	O	O	O	O
auto instance recovery	O	O	O	O
tablespace recovery	O	O	O	O
file recovery	O	O	O	O
change tracking	X	X	O	O

## Database Information

### DICTIONARY\_SCHEMA Schema

The following is a feature matrix for DICTIONARY\_SCHEMA schema.

**Table 4-5** Feature matrix for DICTIONARY\_SCHEMA schema

Family	Feature	2.x	3.x	20c.1	21c.1
Views of ALL_family	ALL_ALL_TABLES	O	O	O	O
	ALL_ARGUMENTS	X	O	O	O
	ALL_CATALOG	O	O	O	O
	ALL_CLUSTER_TABLES	X	O	O	O
	ALL_COL_COMMENTS	O	O	O	O
	ALL_COL_PLACE	X	X	X	X
	ALL_COL_PRIVS	O	O	O	O
	ALL_COL_PRIVS_MADE	O	O	O	O
	ALL_COL_PRIVS_RECD	O	O	O	O
	ALL_CONSTRAINTS	O	O	O	O
	ALL_CONS_COLUMNS	O	O	O	O
	ALL_DB_PRIVS	O	O	O	O
	ALL_DB_PRIVS_MADE	O	O	O	O
	ALL_DB_PRIVS_RECD	O	O	O	O
	ALL_DEPENDENCIES	X	O	O	O
	ALL_GLOBAL_SECONDARY_INDEXES	X	O	O	O
	ALL_GSI_PLACE	X	O	O	O
	ALL_INDEXES	O	O	O	O
	ALL_IND_COLUMNS	O	O	O	O
	ALL_IND_PLACE	X	O	O	O
	ALL_NONSCHEMA_COMMENTS	O	O	O	O
	ALL_OBJECTS	O	O	O	O
	ALL_PACKAGE_PRIVS	X	X	O	O
	ALL_PACKAGE_PRIV_MADE	X	X	O	O
	ALL_PACKAGE_PRIV_RECD	X	X	O	O
	ALL_PROCEDURES	X	O	O	O
	ALL_PROC_PRIVS	X	O	O	O
	ALL_PROC_PRIV_MADE	X	O	O	O
	ALL_PROC_PRIV_RECD	X	O	O	O
	ALL_SCHEMAS	O	O	O	O
	ALL_SCHEMA_PATH	O	O	O	O
	ALL_SCHEMA_PRIVS	O	O	O	O
	ALL_SCHEMA_PRIVS_MADE	O	O	O	O

Family	Feature	2.x	3.x	20c.1	21c.1
	ALL_SCHEMA_PRIVS_RECD	O	O	O	O
	ALL_SEQUENCES	O	O	O	O
	ALL_SEQ_PRIVS	O	O	O	O
	ALL_SEQ_PRIVS_MADE	O	O	O	O
	ALL_SEQ_PRIVS_RECD	O	O	O	O
	ALL_SHARD_KEY_COLUMNS	X	O	O	O
	ALL_SOURCE	X	O	O	O
	ALL_SYNONYMS	O	O	O	O
	ALL_TABLES	O	O	O	O
	ALL_TAB_COLS	O	O	O	O
	ALL_TAB_COLUMNS	O	O	O	O
	ALL_TAB_COMMENTS	O	O	O	O
	ALL_TAB_IDENTITY_COLS	O	O	O	O
	ALL_TAB_PLACE	X	O	O	O
	ALL_TAB_SHARDS	X	O	O	O
	ALL_TAB_PRIVS	O	O	O	O
	ALL_TAB_PRIVS_MADE	O	O	O	O
	ALL_TAB_PRIVS_RECD	O	O	O	O
	ALL_TBS_PRIVS	O	O	O	O
	ALL_TBS_PRIVS_MADE	O	O	O	O
	ALL_TBS_PRIVS_RECD	O	O	O	O
	ALL_USERS	O	O	O	O
	ALL_VIEWS	O	O	O	O
	DBA_ALL_TABLES	O	O	O	O
	DBA_ARGUMENTS	X	O	O	O
	DBA_CATALOG	O	O	O	O
	DBA_CLUSTER	X	O	O	O
	DBA_CLUSTER_COMMENTS	X	O	O	O
	DBA_CLUSTER_TABLES	X	O	O	O
	DBA_COL_COMMENTS	O	O	O	O
	DBA_COL_PLACE	X	X	X	X
	DBA_COL_PRIVS	O	O	O	O
	DBA_CONSTRAINTS	O	O	O	O
	DBA_CONS_COLUMNS	O	O	O	O
	DBA_DB_PRIVS	O	O	O	O
	DBA_DEPENDENCIES	X	O	O	O
	DBA_EXTENTS	O	O	O	O
	DBA_GLOBAL_SECONDARY_INDEXES	X	O	O	O
	DBA_GSI_PLACE	X	O	O	O
	DBA_INDEXES	O	O	O	O

Family	Feature	2.x	3.x	20c.1	21c.1	
Views of DBA_family	DBA_IND_COLUMNS	O	O	O	O	
	DBA_IND_PLACE	X	O	O	O	
	DBA_NONSCHEMA_COMMENTS	O	O	O	O	
	DBA_OBJECTS	O	O	O	O	
	DBA_PACKAGE_PRIVS	X	X	O	O	
	DBA_PROCEDURES	X	O	O	O	
	DBA_PROC_PRIVS	X	O	O	O	
	DBA_PROFILES	O	O	O	O	
	DBA_RECYCLEBIN	X	X	O	O	
	DBA_SCHEMAS	O	O	O	O	
	DBA_SCHEMA_PATH	O	O	O	O	
	DBA_SCHEMA_PRIVS	O	O	O	O	
	DBA_SEQUENCES	O	O	O	O	
	DBA_SEQ_PRIVS	O	O	O	O	
	DBA_SHARD_KEY_COLUMNS	X	O	O	O	
	DBA_SOURCE	X	O	O	O	
	DBA_STAT_SYSTEM	X	O	O	O	
	DBA_SYNONYMS	O	O	O	O	
	DBA_SYS_PRIVS	O	O	O	O	
	DBA_TABLES	O	O	O	O	
	DBA_TABLESPACES	O	O	O	O	
	DBA_TAB_COLS	O	O	O	O	
	DBA_TAB_COLUMNS	O	O	O	O	
	DBA_TAB_COMMENTS	O	O	O	O	
	DBA_TAB_IDENTITY_COLS	O	O	O	O	
	DBA_TAB_PLACE	X	O	O	O	
	DBA_TAB_PRIVS	O	O	O	O	
	DBA_TAB_SHARDS	X	O	O	O	
	DBA_TBS_PRIVS	O	O	O	O	
	DBA_USERS	O	O	O	O	
	DBA_VIEWS	O	O	O	O	
		USER_ALL_TABLES	O	O	O	O
		USER_ARGUMENTS	X	O	O	O
USER_CATALOG		O	O	O	O	
USER_CLUSTER_TABLES		X	O	O	O	
USER_COL_COMMENTS		O	O	O	O	
USER_COL_PLACE		X	X	X	X	
USER_COL_PRIVS		O	O	O	O	
USER_COL_PRIVS_MADE		O	O	O	O	
USER_COL_PRIVS_REC'D	O	O	O	O		

Family	Feature	2.x	3.x	20c.1	21c.1
Views of USER_family	USER_CONSTRAINTS	O	O	O	O
	USER_CONS_COLUMNS	O	O	O	O
	USER_DEPENDENCIES	X	O	O	O
	USER_EXTENTS	O	O	O	O
	USER_GLOBAL_SECONDARY_INDEXES	X	O	O	O
	USER_GSI_PLACE	X	O	O	O
	USER_INDEXES	O	O	O	O
	USER_IND_COLUMNS	O	O	O	O
	USER_IND_PLACE	X	O	O	O
	USER_OBJECTS	O	O	O	O
	USER_PACKAGE_PRIVS	X	X	O	O
	USER_PACKAGE_PRIVS_MADE	X	X	O	O
	USER_PACKAGE_PRIVS_RECD	X	X	O	O
	USER_PROCEDURES	X	O	O	O
	USER_PROC_PRIVS	X	O	O	O
	USER_PROC_PRIVS_MADE	X	O	O	O
	USER_PROC_PRIVS_RECD	X	O	O	O
	USER_RECYCLEBIN	X	X	O	O
	USER_SCHEMAS	O	O	O	O
	USER_SCHEMA_PATH	O	O	O	O
	USER_SCHEMA_PRIVS	O	O	O	O
	USER_SCHEMA_PRIVS_MADE	O	O	O	O
	USER_SCHEMA_PRIVS_RECD	O	O	O	O
	USER_SEQUENCES	O	O	O	O
	USER_SEQ_PRIVS	O	O	O	O
	USER_SEQ_PRIVS_MADE	O	O	O	O
	USER_SEQ_PRIVS_RECD	O	O	O	O
	USER_SHARD_KEY_COLUMNS	X	O	O	O
	USER_SOURCE	X	O	O	O
	USER_SYNONYMS	O	O	O	O
	USER_SYS_PRIVS	O	O	O	O
	USER_TABLES	O	O	O	O
	USER_TABLESPACES	O	O	O	O
	USER_TAB_COLS	O	O	O	O
	USER_TAB_COLUMNS	O	O	O	O
	USER_TAB_COMMENTS	O	O	O	O
USER_TAB_IDENTITY_COLS	O	O	O	O	
USER_TAB_PLACE	X	O	O	O	
USER_TAB_PRIVS	O	O	O	O	
USER_TAB_PRIVS_MADE	O	O	O	O	

Family	Feature	2.x	3.x	20c.1	21c.1
	USER_TAB_PRIVS_RECD	O	O	O	O
	USER_TAB_SHARDS	X	O	O	O
	USER_USERS	O	O	O	O
	USER_VIEWS	O	O	O	O
Other views	AUDIT_POLICIES	X	O	O	O
	AUDIT_POLICY_ENABLED	X	O	O	O
	AUDIT_POLICY_OPTIONS	X	O	O	O
	AUDIT_TRAIL	X	O	O	O
	DATABASE_PROPERTIES	O	O	O	O
	DBC_TABLE_TYPE_INFO	O	O	O	O
	DICTIONARY	O	O	O	O
	DICT_COLUMNS	O	O	O	O
	IMPLEMENTATION_INFO	O	O	O	O
	IMPLEMENTATION_INFO_BASE	O	O	O	O
	JDBC_CLIENT_PROPS	O	O	O	O
	PRODUCT	O	O	O	O
	SESSION_PRIVS	O	O	O	O
SUPPLEMENTAL_LOG_TABLE_INFO	O	O	O	O	
Aliased synonym	COLS	O	O	O	O
	DICT	O	O	O	O
	IND	O	O	O	O
	OBJ	O	O	O	O
	RECYCLEBIN	X	X	O	O
	SEQ	O	O	O	O
	TABS	O	O	O	O

## INFORMATION\_SCHEMA Schema

The following is a feature matrix for INFORMATION\_SCHEMA schema.

**Table 4-6** Feature matrix for INFORMATION\_SCHEMA schema

Feature	2.x	3.x	20c.1	21c.1
COLUMNS	O	O	O	O
COLUMN_PRIVILEGES	O	O	O	O
CONSTRAINT_COLUMN_USAGE	O	O	O	O
CONSTRAINT_TABLE_USAGE	O	O	O	O
INFORMATION_SCHEMA_CATALOG_NAME	O	O	O	O
KEY_COLUMN_USAGE	O	O	O	O
MODULES	X	X	O	O
MODULE_BODY	X	X	O	O

Feature	2.x	3.x	20c.1	21c.1
MODULE_BODY_MODULE_USAGE	X	X	O	O
MODULE_BODY_ROUTINE_USAGE	X	X	O	O
MODULE_BODY_SEQUENCE_USAGE	X	X	O	O
MODULEBODY_TABLE_USAGE	X	X	O	O
MODULE_MODULE_USAGE	X	X	O	O
MODULE_PRIVILEGES	X	X	O	O
MODULE_ROUTINE_USAGE	X	X	O	O
MODULE_SEQUENCE_USAGE	X	X	O	O
MODULE_TABLE_USAGE	X	X	O	O
PARAMETERS	X	O	O	O
REFERENTIAL_CONSTRAINTS	O	O	O	O
ROUTINES	X	O	O	O
ROUTINE_MODULE_USAGE	X	X	O	O
ROUTINE_PRIVILEGES	X	O	O	O
ROUTINE_ROUTINE_USAGE	X	O	O	O
ROUTINE_SEQUENCE_USAGE	X	O	O	O
ROUTINE_TABLE_USAGE	X	O	O	O
SCHEMATA	O	O	O	O
SEQUENCES	O	O	O	O
SQL_FEATURES	O	O	O	O
SQL_IMPLEMENTATION_INFO	O	O	O	O
SQL_PACKAGES	O	O	O	O
SQL_PARTS	O	O	O	O
SQL_SIZING	O	O	O	O
STATISTICS	O	O	O	O
TABLES	O	O	O	O
TABLE_CONSTRAINTS	O	O	O	O
TABLE_PRIVILEGES	O	O	O	O
USAGE_PRIVILEGES	O	O	O	O
VIEWS	O	O	O	O
VIEW_MODULE_USAGE	X	X	O	O
VIEW_ROUTINE_USAGE	X	O	O	O
VIEW_TABLE_USAGE	O	O	O	O

## PERFORMANCE\_VIEW\_SCHEMA Schema

The following is a feature matrix for PERFORMANCE\_VIEW\_SCHEMA schema.



**Table 4-7** Feature matrix for PERFORMANCE\_VIEW\_SCHEMA schema

Feature	2.x	3.x	20c.1	21c.1
GV\$____	X	O	O	O
V\$AGABLE_INFO	X	O	O	O
V\$ARCHIVELOG	O	O	O	O
V\$AUDITABLE_DB_PRIVILEGES	X	O	O	O
V\$AUDITABLE_SYSTEM_ACTIONS	X	O	O	O
V\$BACKUP	O	O	O	O
V\$BALANCER	O	O	O	O
V\$BCH	X	X	O	O
V\$BUFFER_STAT	X	X	O	O
V\$CLUSTER_DISPATCHER	X	O	O	O
V\$CLUSTER_LOCATION	X	O	O	O
V\$CLUSTER_MEMBER	X	O	O	O
V\$COLUMNS	O	O	O	O
V\$CONTROLFILE	O	O	O	O
V\$DATAFILE	O	O	O	O
V\$DB_CHANGE_TRACKING	X	X	O	O
V\$DB_FILE	O	O	O	O
V\$DISPATCHER	O	O	O	O
V\$ERROR_CODE	O	O	O	O
V\$GLOBAL_TRANSACTION	O	O	O	O
V\$JOURNALING	X	O	O	O
V\$INCREMENTAL_BACKUP	O	O	O	O
V\$INSTANCE	O	O	O	O
V\$KEYWORDS	O	O	O	O
V\$LATCH	O	O	O	O
V\$LOCK_WAIT	O	O	O	O
V\$LOCKED_OBJECT	X	X	O	O
V\$LOGFILE	O	O	O	O
V\$PLAN_HISTORY	X	X	X	O
V\$PLAN_HISTORY_LATEST	X	X	X	O
V\$PROCESS_MEM_STAT	O	O	O	O
V\$PROCESS_SQL_STAT	O	O	O	O
V\$PROCESS_STAT	O	O	O	O
V\$PROPERTY	O	O	O	O
V\$PSM_RESERVED_WORDS	X	O	O	O
V\$QUEUE	O	O	O	O
V\$RESERVED_WORDS	O	O	O	O
V\$SESSION	O	O	O	O
V\$SESSION_AUDIT	X	O	O	O

Feature	2.x	3.x	20c.1	21c.1
V\$SESSION_CONNECT_INFO	O	O	O	O
V\$SESSION_EVENT	X	O	O	O
V\$SESSION_MEM_STAT	O	O	O	O
V\$SESSION_MEM_USAGE	X	X	X	O
V\$SESSION_SQL_STAT	O	O	O	O
V\$SESSION_STAT	O	O	O	O
V\$SESSION_WAIT	X	O	O	O
V\$SHARED_MODE	O	O	O	O
V\$SHARED_SERVER	O	O	O	O
V\$SHM_SEGMENT	O	O	O	O
V\$SPROPERTY	O	O	O	O
V\$SQLFN_METADATA	O	O	O	O
V\$SQL_CACHE	O	O	O	O
V\$SQL_COMMAND	X	O	O	O
V\$SQL_HISTORY	X	O	O	O
V\$STATEMENT	O	O	O	O
V\$SYSTEM_EVENT	X	O	O	O
V\$SYSTEM_MEM_STAT	O	O	O	O
V\$SYSTEM_SQL_STAT	O	O	O	O
V\$SYSTEM_STAT	O	O	O	O
V\$TABLES	O	O	O	O
V\$TABLESPACE	O	O	O	O
V\$TABLESPACE_STAT	X	O	O	O
V\$TRANSACTION	O	O	O	O
V\$WAIT_EVENT_CLASS_NAME	X	O	O	O
V\$WAIT_EVENT_NAME	X	O	O	O
V\$XA_TRANSATION	X	O	O	O

## Server Property

The following is a feature matrix for server property.

**Table 4-8** Feature matrix for server property

Feature	2.x	3.x	20c.1	21c.1
AGING_INTERVAL	O	O	O	O
AGING_PLAN_INTERVAL	O	O	O	O
ARCHIVELOG_DIR	O	X	X	X
ARCHIVELOG_DIR_1 ~ DIR_10	O	O	O	O
ARCHIVELOG_FILE	O	O	O	O
ARCHIVELOG_MODE	O	O	O	O
BACKUP_DIR_1 ~ DIR_10	O	O	O	O
BLOCK_READ_COUNT	O	O	O	O
BROADCAST_INDEX_REBUILD_PROTOCOL	X	X	X	O
BROADCAST_REBALANCE_PROTOCOL	X	X	O	O
BUFFER_CACHE_SIZE	X	X	O	O
BUFFER_CHECKPOINT_LIST_COUNT	X	X	O	X
BUFFER_FLUSH_THREADS	X	X	O	X
BUFFER_FLUSHING_INTERVAL	X	X	O	X
BUFFER_FREE_LIST_COUNT	X	X	O	O
BUFFER_HASH_BUCKETS	X	X	O	O
BUFFER_HOT_REGION_CRITERIA	X	X	O	O
BUFFER_HOT_REGION_PERCENT	X	X	O	O
BUFFER_LRU_LIST_COUNT	X	X	O	O
BUFFER_MULTIPAGE_READ_COUNT	X	X	O	O
BUFFER_PREFETCH_PAGE_COUNT	X	X	X	O
BULK_IO_PAGE_COUNT	O	O	O	O
CDISPATCHER_HOT_POLICY_INTERVAL	X	O	O	O
CDISPATCHER_LOCKLESS_THREADS	X	X	O	O
CDISPATCHER_SOCKET_BUFFER_SIZE	X	O	O	O
CDISPATCHER_THREADS	X	O	O	O
CHANGE_TRACKING	X	X	O	O
CHANGE_TRACKING_EXTENT_SIZE	X	X	O	O
CHANGE_TRACKING_FILE	X	X	O	O
CHAR_LENGTH_UNITS	O	O	O	O
CHARACTER_SET	O	O	O	O
CHECK_DEDICATE_CONNECTION_INTERVAL	X	O	O	O
CHECK_DEDICATE_SOCKET	X	X	X	X
CLIENT_MAX_COUNT	O	O	O	O
CLIENT_NUMA_POLICY	X	O	O	O

Feature	2.x	3.x	20c.1	21c.1
CLOSE_PSM_CHILD_STMTS	X	O	O	O
CLUSTER_ASYNC_COMMIT	X	O	O	O
CLUSTER_ASYNC_REPLICATION	X	O	O	O
CLUSTER_CM_BUFFER_COUNT	X	O	O	O
CLUSTER_CM_BUFFER_SIZE	X	O	O	O
CLUSTER_CM_READ_BUFFER_SIZE	X	O	O	O
CLUSTER_COMMIT_SLAVES	X	O	O	O
CLUSTER_COMMIT_STREAM_ISOLATION	X	O	O	O
CLUSTER_CONNECTION	X	O	O	O
CLUSTER_CONNECTION_TIMEOUT_SEC	X	O	O	O
CLUSTER_DATA_SYNC_SERVERS	X	O	O	O
CLUSTER_DEADLOCK_TIMEOUT	X	X	O	O
CLUSTER_DISPATCHER_IN_QUEUE_SIZE	X	O	O	O
CLUSTER_DISPATCHER_NUMA_STREAM_MAP	X	O	O	O
CLUSTER_DISPATCHER_OUT_QUEUE_SIZE	X	O	O	O
CLUSTER_HEARTBEAT_INTERVAL	X	O	O	O
CLUSTER_HEARTBEAT_RETRY_COUNT	X	O	O	O
CLUSTER_IGNORE_INACTIVE_MEMBER	X	O	O	O
CLUSTER_MAX_PACKET_SIZE	X	O	O	O
CLUSTER_MAX_PAYLOAD_SIZE	X	O	O	O
CLUSTER_PACKET_ALLOCATION_TIMEOUT	X	O	O	O
CLUSTER_SERVER_RESPONSE_QUEUE_SIZE	X	O	O	O
CLUSTER_SESSION_HASH_BUCKETS	X	X	O	O
CLUSTER_SPLIT_BRAIN_RESOLUTION_POLICY	X	O	O	O
CLUSTER_SPLIT_BRAIN_RETRY_COUNT	X	O	O	O
COMMITTER_HOT_POLICY_INTERVAL	X	O	O	O
CONTROL_FILE_0 ~ FILE_7	O	O	O	O
CONTROL_FILE_COUNT	O	O	O	O
CONTROL_FILE_TEMP_NAME	O	O	O	O
COORDINATOR_COMMIT_WRITE_MODE	X	O	O	O
CSERVERS	X	O	O	O
DA_CLIENT_NUMA_MODE	X	O	O	O
DATA_STORE_MODE	O	O	O	O
DATABASE_ACCESS_MODE	O	O	O	O
DATABASE_INSTANCE_NAME	X	O	O	O
DDL_AUTOCOMMIT	O	O	O	O
DDL_LOCK_TIMEOUT	O	O	O	O
DEADLOCK_PRIORITY	X	X	O	O
DEFAULT_GLOBAL_SECONDARY_INDEX_CREATION	X	O	O	O
DEFAULT_INDEX_LOGGING	O	O	X	X

Feature	2.x	3.x	20c.1	21c.1
DEFAULT_INDEX_PCTFREE	X	O	O	O
DEFAULT_INITRANS	O	O	O	O
DEFAULT_MAXTRANS	O	O	O	O
DEFAULT_PCTFREE	O	O	O	O
DEFAULT_PCTUSED	O	O	O	O
DEFAULT_REMOVAL_BACKUP_FILE	O	O	O	O
DEFAULT_REMOVAL_OBSOLETE_BACKUP_LIST	O	O	O	O
DEFAULT_SHARDING	X	O	O	O
DISABLE_DDL	X	X	X	O
DISABLE_DDL_CDC_GIVEUP	O	O	O	O
DISABLE_SERIAL_DDL	X	X	X	O
DISABLE_UPDATE_PK_CDC_GIVEUP	O	O	O	O
DISALLOWED_PROTOCOL_TARGETTYPE	X	O	O	O
DISALLOWED_PROTOCOL_TARGETTYPE_WITH_ALL	X	O	O	O
DISALLOWED_PROTOCOL_TARGETTYPE_WITH_NAME	X	O	O	O
DISPATCHERS	O	O	O	O
DISPATCHER_CM_BUFFER_SIZE	O	O	O	O
DISPATCHER_CM_UNIT_SIZE	O	O	O	O
DISPATCHER_CONNECTIONS	O	O	O	O
DISPATCHER_HOT_POLICY_INTERVAL	X	O	O	O
DISPATCHER_LOAD_BALANCING	X	O	O	O
DISPATCHER_NUMA_STREAM_MAP	X	O	O	O
DISPATCHER_QUEUE_SIZE	O	O	O	O
DISPATCHER_REQUEST_MINI_QUEUE_COUNT	X	O	O	O
DISPATCHER_RESPONSE_MINI_QUEUE_COUNT	X	O	O	O
EXECUTE_INST_HASH_TABLE_USING_AVAILABLE_MEMORY	X	X	X	O
FETCH_FAILOVER	X	O	O	O
GLOBAL_CONNECTION_ALLOW_SESSION_DEPENDENCY	X	O	O	O
GLOBAL_JOURNAL_BUFFER_SIZE	X	O	O	O
GLOBAL_JOURNAL_BUFFER_TOTAL_MAX_SIZE	X	O	O	O
GLOBAL_PROPERTY_LOCK_TIMEOUT	X	O	O	O
GLOBAL_TRANSACTION_COMMIT_WRITE_MODE	X	O	O	O
GLOBAL_TRANSACTION_ISOLATION_SCOPE	X	O	O	O
GLOBAL_TRANSACTION_LOG_DIR	X	O	O	O
GLOBAL_TRANSACTION_LOG_FILE_SIZE	X	O	O	O
GMASTER_NUMA_NODE	X	O	O	O
GMON_AUTOSTART	X	O	O	O
HINT_ERROR	O	O	O	O
IDLE_TIMEOUT	O	O	O	O
IN_DOUBT_DECISION	O	O	O	O

Feature	2.x	3.x	20c.1	21c.1
IN_KEY_RANGE_ARRAY_COUNT	X	X	O	O
INCREMENTAL_BACKUP_SCAN_BUFFER_SIZE	X	X	O	O
INDEX_BUILD_PARALLEL_FACTOR	O	O	O	O
INDEX_LOGGING_THROTTLING	X	X	X	O
INDEX_REBUILD_BLOCK_READ_COUNT	X	X	O	O
INDEX_TREE_MERGE_PARALLEL_FACTOR	X	O	O	O
INST_ALLOCATOR_COUNT	X	O	O	O
INST_HASH_TABLE_BUCKET_MAX_COUNT	X	X	X	O
INST_TABLE_BLOCK_SIZE	X	O	O	O
IPC_CHANNEL_COUNT	X	X	X	O
JOURNAL_TEMP_DIR	X	O	O	O
KEEPALIVE_IDLE_TIME	O	O	O	O
LOCAL_CLUSTER_MEMBER	X	O	O	O
LOCAL_CLUSTER_MEMBER_HOST	X	O	O	O
LOCAL_CLUSTER_MEMBER_PORT	X	O	O	O
LOCAL_JOURNAL_BUFFER_SIZE	X	O	O	O
LOCATION_FILE	X	O	O	O
LOCATOR_QUERY_TIMEOUT	X	O	O	O
LOCK_HASH_TABLE_SIZE	O	O	O	O
LOCKLESS_CSERVERS	X	X	O	O
LOG_BLOCK_SIZE	O	O	O	O
LOG_BUFFER_SIZE	O	O	O	O
LOG_DIR	O	O	O	O
LOG_FILE_SIZE	O	O	O	O
LOG_GROUP_COUNT	O	O	O	O
LOG_MIRROR_MODE	O	O	O	O
LOG_MIRROR_SHARED_MEMORY_STATIC_SIZE	O	O	O	O
LOG_MIRROR_TIMEOUT	O	O	O	O
LOG_SYNC_INTERVAL	O	O	O	O
LOG_SYNC_INTERVAL_MSEC	X	O	O	O
MAX_GROUP_COUNT	X	O	O	O
MAX_JOURNAL_FILE_SIZE	X	O	O	O
MAX_NODE_COUNT	X	O	O	O
MAXIMUM_CONCURRENT_ACTIVITIES	O	O	O	O
MAXIMUM_FILE_CACHE_SIZE	X	X	X	O
MAXIMUM_FLANGE_COUNT	X	O	O	O
MAXIMUM_FLUSH_BUFFER_PAGE_COUNT	X	X	X	O
MAXIMUM_FLUSH_LOG_BLOCK_COUNT	O	O	O	O
MAXIMUM_FLUSH_PAGE_COUNT	O	O	O	O
MAXIMUM_INDEX_REBUILD_JOURNAL_REPLAY_COUNT	X	X	O	O

Feature	2.x	3.x	20c.1	21c.1
MAXIMUM_JOURNAL_REPLAY_COUNT	X	O	O	O
MAXIMUM_NAMED_CURSOR_COUNT	O	O	O	O
MAXIMUM_PACKAGE_INSTANCE_COUNT	X	X	X	O
MAXIMUM_SESSION_CM_BUFFER_SIZE	O	O	O	O
MEASURE_CLUSTER_LATENCY	X	O	O	O
MEDIA_RECOVERY_LOG_BUFFER_SIZE	O	X	X	X
MEMORY_MERGE_RUN_COUNT	O	O	O	O
MEMORY_SORT_RUN_SIZE	O	O	O	O
MIN_SAMPLE_ROW_COUNT	X	O	O	O
MINIMUM_UNDO_PAGE_COUNT	O	O	O	O
NET_BUFFER_SIZE	O	O	O	O
NLS_DATE_FORMAT	O	O	O	O
NLS_TIME_FORMAT	O	O	O	O
NLS_TIME_WITH_TIME_ZONE_FORMAT	O	O	O	O
NLS_TIMESTAMP_FORMAT	O	O	O	O
NLS_TIMESTAMP_WITH_TIME_ZONE_FORMAT	O	O	O	O
NUMA	X	O	O	O
NUMA_MAP	X	O	O	O
OFFLINE_MEMBER_AFTER_FAILOVER	X	O	O	O
ONLINE_INDEX_REBUILD_JOURNAL_REPLAY_THRESHOLD	X	X	O	O
ONLINE_JOURNAL_REPLAY_THRESHOLD	X	O	O	O
OS_GROUP_ACCESS	X	O	O	O
PACKET_COMPRESSION_THRESHOLD	X	X	O	O
PAGE_CHECKSUM_TYPE	O	O	O	O
PARALLEL_IO_FACTOR	O	O	O	O
PARALLEL_IO_GROUP_1 ~ GROUP_16	O	O	O	O
PARALLEL_LOAD_FACTOR	O	O	O	O
PENDING_LOG_BUFFER_COUNT	O	O	O	O
PLAN_CACHE	O	O	O	O
PLAN_CACHE_SIZE	O	O	O	O
PLAN_HISTORY	X	X	X	O
PLAN_HISTORY_SIZE	X	X	X	O
PRIVATE_STATIC_AREA_INIT_SIZE	X	X	O	O
PRIVATE_STATIC_AREA_NEXT_SIZE	X	X	O	O
PRIVATE_STATIC_AREA_SHRINK_THRESHOLD	X	X	O	O
PRIVATE_STATIC_AREA_SIZE	O	O	O	O
PROCESS_MAX_COUNT	O	O	O	O
QUERY_TIMEOUT	O	O	O	O
READABLE_ARCHIVELOG_DIR_COUNT	O	O	O	O
READABLE_BACKUP_DIR_COUNT	O	O	O	O

Feature	2.x	3.x	20c.1	21c.1
REBALANCE_BLOCK_READ_COUNT	X	O	O	O
RECOMPILE_CHECK_MINIMUM_PAGE_COUNT	O	X	X	X
RECOMPILE_PAGE_PERCENT	O	X	X	X
RECOVERY_LOG_BUFFER_SIZE	X	O	O	O
RECYCLEBIN	X	X	O	O
REDO_LOG_COMPRESSION_THRESHOLD	X	O	O	O
REFINE_RELATION	O	O	O	O
SESSION_FATAL_BEHAVIOR	O	O	O	O
SESSION_MEMORY_INIT_SIZE	X	O	O	O
SESSION_MEMORY_SHRINK_THRESHOLD	X	O	O	O
SHARED_MEMORY_ADDRESS	O	O	O	O
SHARED_MEMORY_STATIC_KEY	O	O	O	O
SHARED_MEMORY_STATIC_NAME	O	O	O	O
SHARED_MEMORY_STATIC_SIZE	O	O	O	O
SHARED_REQUEST_QUEUE_COUNT	O	O	O	O
SHARED_SERVERS	O	O	O	O
SHARED_SESSION	O	O	O	O
SNAPSHOT_STATEMENT_TIMEOUT	O	O	O	O
SQL_HISTORY_SIZE	X	O	O	O
SUPPLEMENTAL_LOG_DATA_PRIMARY_KEY	O	O	O	O
SYSTEM_DISK_DATA_TABLESPACE_SIZE	X	X	O	O
SYSTEM_FILE_IO	O	O	O	O
SYSTEM_LOGGER_DIR	O	O	O	O
SYSTEM_MEMORY_AUX_TABLESPACE_SIZE	X	O	O	O
SYSTEM_MEMORY_DATA_TABLESPACE_SIZE	O	O	O	O
SYSTEM_MEMORY_DICT_TABLESPACE_SIZE	O	O	O	O
SYSTEM_MEMORY_TEMP_TABLESPACE_SIZE	O	O	O	O
SYSTEM_MEMORY_UNDO_TABLESPACE_SIZE	O	O	O	O
SYSTEM_TABLESPACE_DIR	O	O	O	O
SYSTEM_UDS_DIR	X	O	O	O
TCP_NODELAY	X	O	O	O
TEMP_SEGMENT_CACHE_SIZE	X	O	O	O
TEMP_UNDO_ENABLED	X	O	O	O
TIMED_STATISTICS	X	O	O	O
TIMER_INTERVAL	O	X	X	O
TIMEZONE	O	O	O	O
TRACE_ALTER_SYSTEM	O	O	O	O
TRACE_DDL	O	O	O	O
TRACE_LOG_ID	O	O	O	O
TRACE_LOG_MSGBUG_SIZE	X	O	O	O



Feature	2.x	3.x	20c.1	21c.1
TRACE_LOG_TIME_DETAIL	O	O	O	O
TRACE_LOGGER	X	O	O	O
TRACE_LOGGER_REMOTE_HOST	X	O	O	O
TRACE_LOGGER_REMOTE_PORT	X	O	O	O
TRACE_LOGIN	O	O	O	O
TRACE_LONG_RUN_CURSOR	O	O	O	O
TRACE_LONG_RUN_SQL	O	O	O	O
TRACE_LONG_RUN_TIMER	X	X	O	O
TRACE_XA	O	O	O	O
TRANSACTION_ALLOCATION_TIMEOUT	X	O	O	O
TRANSACTION_COMMIT_WRITE_MODE	O	O	O	O
TRANSACTION_MAXIMUM_UNDO_PAGE_COUNT	O	O	O	O
TRANSACTION_TABLE_SIZE	O	O	O	O
TRANSACTION_TIMEOUT	X	O	O	O
UNDO_RELATION_ALLOCATION_TIMEOUT	X	O	O	O
UNDO_RELATION_COUNT	O	O	O	O
UNDO_SHRINK_THRESHOLD	O	O	O	O
USE_LARGE_PAGES	X	X	O	O
USER_DATA_TABLESPACE_MEDIA_TYPE	X	X	O	O
USER_DATA_TABLESPACE_SIZE	X	X	O	O
USER_DISK_DATA_TABLESPACE_NEXTSIZE	X	X	O	O
USER_TEMP_TABLESPACE_SIZE	O	O	O	O
XA_TRANSACTION_IDLE_TIMEOUT	X	X	O	O

# SQL

## SQL Element

### Data Type

The following is a feature matrix for data type.

**Table 4-9** Feature matrix for data type

Type	Feature	2.x	3.x	20c.1	21c.1
Character string type	CHAR	O	O	O	O
	VARCHAR	O	O	O	O
	LONG VARCHAR	O	O	O	O
Binary string type	BINARY	O	O	O	O
	VARBINARY	O	O	O	O
	LONG VARBINARY	O	O	O	O
Decimal number type	SMALLINT	O	O	O	O
	INTEGER	O	O	O	O
	BIGINT	O	O	O	O
	NUMERIC	O	O	O	O
	DECIMAL	X	O	O	O
	NUMBER	O	O	O	O
	REAL	O	O	O	O
	DOUBLE PRECISION	O	O	O	O
Binary number type	FLOAT	O	O	O	O
	NATIVE_SMALLINT	O	O	O	O
	NATIVE_INTEGER	O	O	O	O
	NATIVE_BIGINT	O	O	O	O
	NATIVE_REAL	O	O	O	O
BOOLEAN type	NATIVE_DOUBLE	O	O	O	O
BOOLEAN	O	O	O	O	
Date/ time type	DATE	O	O	O	O
	TIME	O	O	O	O
	TIME WITH TIME ZONE	O	O	O	O
	TIMESTAMP	O	O	O	O
	TIMESTAMP WITH TIME ZONE	O	O	O	O
	INTERVAL YEAR TO MONTH	O	O	O	O
	INTERVAL YEAR	O	O	O	O
	INTERVAL MONTH	O	O	O	O
	INTERVAL DAY TO SECOND	O	O	O	O

Type	Feature	2.x	3.x	20c.1	21c.1
INTERVAL type	INTERVAL DAY	0	0	0	0
	INTERVAL HOUR	0	0	0	0
	INTERVAL MINUTE	0	0	0	0
	INTERVAL SECOND	0	0	0	0
	INTERVAL DAY TO HOUR	0	0	0	0
	INTERVAL DAY TO MINUTE	0	0	0	0
	INTERVAL HOUR TO MINUTE	0	0	0	0
	INTERVAL HOUR TO SECOND	0	0	0	0
	INTERVAL MINUTE TO SECOND	0	0	0	0
ROWID type	ROWID	0	0	0	0

## Function

The following is a feature matrix for function.

**Table 4-10** Feature matrix for function

Feature	2.x	3.x	20c.1	21c.1
expr1 * expr2	0	0	0	0
expr1 + expr2	0	0	0	0
datetime + interval	0	0	0	0
+ expr	0	0	0	0
expr1 - expr2	0	0	0	0
datetime - interval	0	0	0	0
- expr	0	0	0	0
expr1 / expr2	0	0	0	0
str1    str2	0	0	0	0
expr <comp> expr	0	0	0	0
expr <comp> ( subquery )	0	0	0	0
( subquery ) <comp> expr	0	0	0	0
( subquery ) <comp> ( subquery )	0	0	0	0
( expr, ... ) <comp> ( expr, ... )	0	0	0	0
( expr, ... ) <comp> ( subquery )	0	0	0	0
( subquery ) <comp> ( expr, ... )	0	0	0	0
expr <comp> {ALL ANY SOME} ( expr, ... )	0	0	0	0
expr <comp> {ALL ANY SOME} ( subquery )	0	0	0	0
( subquery ) <comp> {ALL ANY SOME} ( expr, ... )	0	0	0	0
( subquery ) <comp> {ALL ANY SOME} ( subquery )	0	0	0	0
( expr, ... ) <comp> {ALL ANY SOME} ( expr_list, ... )	0	0	0	0
( expr, ... ) <comp> {ALL ANY SOME} ( subquery )	0	0	0	0
( subquery ) <comp> {ALL ANY SOME} ( expr_list, ... )	0	0	0	0

Feature	2.x	3.x	20c.1	21c.1
ABS( num )	O	O	O	O
ACOS( num )	O	O	O	O
ADDDATE( date, interval )	O	O	O	O
ADDDATE( expr, days )	O	O	O	O
ADDTIME( expr1, expr2 )	O	O	O	O
ADD_MONTHS( date, number )	O	O	O	O
AND	O	O	O	O
ASCII( char )	X	O	O	O
ASIN( num )	O	O	O	O
ATAN( num )	O	O	O	O
ATAN2( num1, num2 )	O	O	O	O
AVG( num )	O	O	O	O
expr1 [NOT] BETWEEN [ASYMMETRIC SYMMETRIC] expr2 AND expr3	O	O	O	O
BITAND( num1, num2 )	O	O	O	O
BITNOT( num )	O	O	O	O
BITOR( num1, num2 )	O	O	O	O
BITXOR( num1, num2 )	O	O	O	O
BIT_LENGTH( str )	O	O	O	O
BYTE_LENGTH( str )	O	O	O	O
CASE .. WHEN .. THEN .. ELSE .. END	O	O	O	O
CASE2( condition, result, ... )	O	O	O	O
CAST( expr AS datatype )	O	O	O	O
CBRT( num )	O	O	O	O
CEIL( num )	O	O	O	O
CEILING( num )	O	O	O	O
CHAR_LENGTH( str )	O	O	O	O
CHARACTER_LENGTH( str )	O	O	O	O
CHR( num )	X	O	O	O
CLOCK_DATE()	O	O	O	O
CLOCK_LOCALTIME()	O	O	O	O
CLOCK_LOCALTIMESTAMP()	O	O	O	O
CLOCK_TIME()	O	O	O	O
CLOCK_TIMESTAMP()	O	O	O	O
COALESCE( expr1, ..., exprN )	O	O	O	O
CONCAT( str1, str2 )	O	O	O	O
CONCATENATE( str1, str2 )	O	O	O	O
CONNECT_BY_ISCYCLE	X	X	X	O
CONNECT_BY_ISLEAF	X	X	X	O
CONNECT_BY_ROOT expr	X	X	X	O

Feature	2.x	3.x	20c.1	21c.1
COS( num )	0	0	0	0
COT( num )	0	0	0	0
COUNT( expr )	0	0	0	0
COUNT(*)	0	0	0	0
CURRENT_CATALOG	0	0	0	0
CURRENT_DATE	0	0	0	0
CURRENT_SCHEMA	0	0	0	0
CURRENT_TIME	0	0	0	0
CURRENT_TIMESTAMP	0	0	0	0
CURRENT_USER	0	0	0	0
seq.CURRVAL	0	0	0	0
CURRVAL( seq )	0	0	0	0
DATEADD( datepart, number, date )	0	0	0	0
DATEDIFF( datepart, startdate, enddate )	0	0	0	0
DATE_ADD( date, interval )	0	0	0	0
DATE_PART( field, datetime )	0	0	0	0
DECODE( expr, comparison, result, ... )	0	0	0	0
DEGREES( radians )	0	0	0	0
DIGEST ( data, type )	X	0	0	0
DUMP( expr )	0	0	0	0
EXISTS( subquery )	0	0	0	0
EXP( num )	0	0	0	0
EXTRACT( field FROM datetime )	0	0	0	0
FACTORIAL( num )	0	0	0	0
FLOOR( num )	0	0	0	0
FROM_BASE64( str )	X	0	0	0
FROM_TZ( timestamp, timezone )	X	X	X	0
GREATEST( expr, ... )	0	0	0	0
HEX( str )	X	0	0	0
expr1 [NOT] IN ( expr, ... )	0	0	0	0
expr1 [NOT] IN ( subquery )	0	0	0	0
subquery [NOT] IN ( <expr_list> )	0	0	0	0
subquery [NOT] IN ( subquery )	0	0	0	0
<expr_list> [NOT] IN ( <expr_list>, ... )	0	0	0	0
<expr_list> [NOT] IN ( subquery )	0	0	0	0
subquery [NOT] IN ( <expr_list>, ... )	0	0	0	0
INITCAP( str )	0	0	0	0
INSTR( str, substr, ... )	0	0	0	0
IS NOT NULL	0	0	0	0
IS NULL	0	0	0	0

Feature	2.x	3.x	20c.1	21c.1
LAST_DAY( date )	O	O	O	O
LAST_IDENTITY_VALUE()	X	O	O	O
LEAST( expr, ... )	O	O	O	O
LENGTH( str )	O	O	O	O
LENGTHB( str )	O	O	O	O
LEVEL	X	X	X	O
string [NOT] LIKE pattern ESCAPE escape_char	O	O	O	O
LN( num )	O	O	O	O
LNNVL( expr )	X	X	O	O
LOCALTIME	O	O	O	O
LOCALTIMESTAMP	O	O	O	O
LOCAL_GROUP_ID()	X	O	O	O
LOCAL_GROUP_NAME()	X	O	O	O
LOCAL_MEMBER_ID()	X	O	O	O
LOCAL_MEMBER_NAME()	X	O	O	O
LOG( num2 )	O	O	O	O
LOG( num1, num2 )	O	O	O	O
LOGON_USER()	O	O	O	O
LOWER( str )	O	O	O	O
LPAD( str, length, fill )	O	O	O	O
LTRIM( str, [ str ] )	O	O	O	O
MAX( expr )	O	O	O	O
MIN( expr )	O	O	O	O
MOD( num1, num2 )	O	O	O	O
MONTHS_BETWEEN( date1, date2 )	X	O	O	O
NEXT_DAY( date, day )	X	O	O	O
seq.NEXTVAL	O	O	O	O
NEXTVAL( seq )	O	O	O	O
NEXT VALUE FOR seq	O	O	O	O
NOT	O	O	O	O
NULLIF( expr1, expr2 )	O	O	O	O
NUMTODSINTERVAL( num, interval_indicator )	X	X	O	O
NUMTODSINTERVAL( num, interval_indicator )	X	X	O	O
NVL( expr1, expr2 )	O	O	O	O
NVL2( expr1, expr2, expr3 )	O	O	O	O
OCTET_LENGTH( str )	O	O	O	O
OVERLAY( str1 PLACING str2 FROM start FOR length )	O	O	O	O
OR	O	O	O	O
PHYSICAL_LENGTH( expr )	X	X	O	O
PI()	O	O	O	O

Feature	2.x	3.x	20c.1	21c.1
POSITION( str1 IN str2 )	O	O	O	O
POWER( num1, num2 )	O	O	O	O
PRIOR expr	X	X	X	O
RADIANS( degrees )	O	O	O	O
RANDOM( min, max )	O	O	O	O
REPEAT( str, num )	O	O	O	O
REPLACE( str, from, to )	O	O	O	O
REVERSE( str )	X	O	O	O
ROUND( num )	O	O	O	O
ROUND( date, fmt )	O	O	O	O
ROWID_GRID_BLOCK_ID( rowid )	X	O	O	O
ROWID_GRID_BLOCK_SEQ( rowid )	X	O	O	O
ROWID_MEMBER_ID( rowid )	X	O	O	O
ROWID_OBJECT_ID( rowid )	O	O	O	O
ROWID_PAGE_ID( rowid )	O	O	O	O
ROWID_ROW_NUMBER( rowid )	O	O	O	O
ROWID_SHARD_ID( rowid )	X	O	O	O
ROWID_TABLESPACE_ID( rowid )	O	O	O	O
ROWNUM	X	O	O	O
RPAD( str, length, fill )	O	O	O	O
RTRIM( str, [ str ] )	O	O	O	O
SESSION_ID()	O	O	O	O
SESSION_SERIAL()	O	O	O	O
SESSION_USER	O	O	O	O
SHARD_GROUP_ID( table, expr )	X	O	O	O
SHARD_GROUP_NAME( table_name, shard_key_value [, ...] )	X	O	O	O
SHARD_ID( table, expr )	X	O	O	O
SHARD_NAME( table_name, shard_key_value [, ...] )	X	O	O	O
SHIFT_LEFT( num, cnt )	O	O	O	O
SHIFT_RIGHT( num, cnt )	O	O	O	O
SIGN( num )	O	O	O	O
SIN( num )	O	O	O	O
SPLIT_PART( str, delimiter, field )	O	O	O	O
SQRT( num )	O	O	O	O
STATEMENT_DATE()	O	O	O	O
STATEMENT_LOCALTIME()	O	O	O	O
STATEMENT_LOCALTIMESTAMP()	O	O	O	O
STATEMENT_TIME()	O	O	O	O
STATEMENT_TIMESTAMP()	O	O	O	O
STATEMENT_VIEW_SCN()	O	O	O	O

Feature	2.x	3.x	20c.1	21c.1
STATEMENT_VIEW_SCN_DCN()	X	O	O	O
STATEMENT_VIEW_SCN_GCN()	X	O	O	O
STATEMENT_VIEW_SCN_LCN()	X	O	O	O
STDDEV( [ ALL   DISTINCT ] expr )	X	O	O	O
STDDEV_POP( expr )	X	O	O	O
STDDEV_SAMP( expr )	X	O	O	O
SUBSTR( str FROM start FOR length )	O	O	O	O
SUBSTR( str, start, length )	O	O	O	O
SUBSTRB( str, start, length )	O	O	O	O
SUBSTRING( str FROM start FOR length )	O	O	O	O
SUBSTRING( str, start, length )	O	O	O	O
SUM( expr )	O	O	O	O
SYSDATE	O	O	O	O
SYS_CONNECT_BY_PATH( expr, 'string' )	X	X	X	O
SYS_EXTRACT_UTC( datetime_with_timezone )	X	O	O	O
SYSTIME	O	O	O	O
SYSTIMESTAMP	O	O	O	O
TAN( num )	O	O	O	O
TO_CHAR( datetime, fmt )	O	O	O	O
TO_CHAR( number, fmt )	O	O	O	O
TO_BASE64( str )	X	O	O	O
TO_DATE( str, fmt )	O	O	O	O
TO_NATIVE_BIGNIT( str, fmt )	X	X	O	O
TO_NATIVE_DOUBLE( str, fmt )	O	O	O	O
TO_NATIVE_INTEGER( str, fmt )	X	X	O	O
TO_NATIVE_REAL( str, fmt )	O	O	O	O
TO_NATIVE_SMALLINT( str, fmt )	X	X	O	O
TO_NUMBER( num, fmt )	O	O	O	O
TO_TIME( str, fmt )	O	O	O	O
TO_TIME_TZ( str, fmt )	O	O	O	O
TO_TIME_WITH_TIME_ZONE( str, fmt )	O	O	O	O
TO_TIMESTAMP( str, fmt )	O	O	O	O
TO_TIMESTAMP_TZ( str, fmt )	O	O	O	O
TO_TIMESTAMP_WITH_TIME_ZONE( str, fmt )	O	O	O	O
TRANSACTION_DATE()	O	O	O	O
TRANSACTION_LOCALTIME()	O	O	O	O
TRANSACTION_LOCALTIMESTAMP()	O	O	O	O
TRANSACTION_TIME()	O	O	O	O
TRANSACTION_TIMESTAMP()	O	O	O	O
TRANSLATE( str, from, to )	O	O	O	O



Feature	2.x	3.x	20c.1	21c.1
TRIM( LEADING TRAILING BOTH trim_char FROM source )	O	O	O	O
TRUNC( num, scale )	O	O	O	O
TRUNC( date, fmt )	O	O	O	O
UPPER( str )	O	O	O	O
UNHEX( str )	X	O	O	O
UNHEX_TO_CHARSTR( str )	X	O	O	O
USER_ID()	O	O	O	O
UUID()	X	O	O	O
VAR_POP( expr )	X	O	O	O
VAR_SAMP( expr )	X	O	O	O
VARIANCE( [ ALL   DISTINCT ] expr )	X	O	O	O
VERSION()	O	O	O	O
WIDTH_BUCKET( num, min, max, cnt )	O	O	O	O

## Object

### SQL Object

The following is a feature matrix for DDL which creates/ drops/ alters an SQL object.

**Table 4-11** Feature matrix for SQL object DDL

Object	Feature	2.x	3.x	20c.1	21c.1
Database object	ALTER DATABASE ARCHIVELOG	O	O	O	O
	ALTER DATABASE ADD LOGFILE	O	O	O	O
	ALTER DATABASE DROP LOGFILE	O	O	O	O
	ALTER DATABASE RENAME LOGFILE	O	O	O	O
	ALTER DATABASE BEGIN/END BACKUP	O	O	O	O
	ALTER DATABASE RECOVER	O	O	O	O
	ALTER DATABASE RECOVER TABLESPACE	O	O	O	O
	ALTER DATABASE REGISTER	O	O	O	O
	ALTER DATABASE RESTORE	O	O	O	O
	ANALYZE SYSTEM	X	O	O	O
COMMENT ON object IS ..	O	O	O	O	
Profile object	CREATE PROFILE	O	O	O	O
	DROP PROFILE	O	O	O	O
	ALTER PROFILE	O	O	O	O
Audit policy object	CREATE AUDIT POLICY	X	O	O	O
	DROP AUDIT POLICY	X	O	O	O
	ALTER AUDIT POLICY	X	O	O	O
	AUDIT POLICY	X	O	O	O
	NOAUDIT POLICY	X	O	O	O
Authorization object	CREATE USER	O	O	O	O
	DROP USER	O	O	O	O
	ALTER USER	O	O	O	O
	GRANT privileges TO	O	O	O	O
	REVOKE privileges FROM	O	O	O	O
Schema object	CREATE SCHEMA	O	O	O	O
	DROP SCHEMA	O	O	O	O
Tablespace object	CREATE MEMORY DATA TABLESPACE	O	O	O	O
	CREATE MEMORY TEMPORARY TABLESPACE	O	O	O	O
	DROP TABLESPACE	O	O	O	O
	ALTER TABLESPACE .. RENAME TO	O	O	O	O
	ALTER TABLESPACE .. BEGIN/END BACKUP	O	O	O	O
	ALTER TABLESPACE .. ADD [DATAFILE MEMORY]	O	O	O	O
	ALTER TABLESPACE .. DROP [DATAFILE MEMORY]	O	O	O	O

Object	Feature	2.x	3.x	20c.1	21c.1
	ALTER TABLESPACE .. RENAME DATAFILE	O	O	O	O
	ALTER TABLESPACE .. { ONLINE   OFFLINE }	O	O	O	O
Table object	CREATE TABLE	O	O	O	O
	CREATE TABLE AS SELECT	O	O	O	O
	CREATE GLOBAL TEMPORARY TABLE	X	O	O	O
	CREATE GLOBAL TEMPORARY TABLE AS SELECT	X	O	O	O
	CREATE IMMUTABLE TABLE	X	X	O	O
	CREATE IMMUTABLE TABLE AS SELECT	X	X	O	O
	DROP TABLE	O	O	O	O
	TRUNCATE TABLE	O	O	O	O
	ALTER TABLE .. STORAGE	O	O	O	O
	ALTER TABLE .. RENAME TO	O	O	O	O
	ALTER TABLE .. ADD COLUMN	O	O	O	O
	ALTER TABLE .. SET UNUSED COLUMN	O	O	O	O
	ALTER TABLE .. ALTER COLUMN	O	O	O	O
	ALTER TABLE .. RENAME COLUMN	O	O	O	O
	ALTER TABLE .. RENAME CONSTRAINT	X	O	O	O
	ALTER TABLE .. ADD CONSTRAINT	O	O	O	O
	ALTER TABLE .. DROP CONSTRAINT	O	O	O	O
	ALTER TABLE .. ALTER CONSTRAINT	O	O	O	O
	ALTER TABLE .. ADD SUPPLEMENTAL LOG	O	O	O	O
	ALTER TABLE .. DROP SUPPLEMENTAL LOG	O	O	O	O
	ALTER TABLE .. READ { ONLY   WRITE }	X	O	O	O
	ANALYZE TABLE	X	O	O	O
	FLASHBACK TABLE	X	X	O	O
PURGE	X	X	O	O	
View object	CREATE VIEW	O	O	O	O
	DROP VIEW	O	O	O	O
	ALTER VIEW	O	O	O	O
Index object	CREATE INDEX	O	O	O	O
	DROP INDEX	O	O	O	O
	ALTER INDEX .. AGING	X	O	O	O
	ALTER INDEX .. STORAGE	O	O	O	O
	ALTER INDEX .. RENAME	X	O	O	O
	ALTER INDEX .. REBUILD	X	X	O	O
Sequence object	CREATE SEQUENCE	O	O	O	O
	DROP SEQUENCE	O	O	O	O
	ALTER SEQUENCE	O	O	O	O
Synonym	CREATE SYNONYM	O	O	O	O
	DROP SYNONYM	O	O	O	O

Object	Feature	2.x	3.x	20c.1	21c.1
object	CREATE PUBLIC SYNONYM	O	O	O	O
	DROP PUBLIC SYNONYM	O	O	O	O
Stored procedure object	CREATE PROCEDURE	X	O	O	O
	DROP PROCEDURE	X	O	O	O
	ALTER PROCEDURE	X	O	O	O
Stored function object	CREATE FUNCTION	X	O	O	O
	DROP FUNCTION	X	O	O	O
	ALTER FUNCTION	X	O	O	O
Package object	CREATE PACKAGE	X	X	O	O
	CREATE PACKAGE BODY	X	X	O	O
	ALTER PACKAGE	X	X	O	O
	DROP PACKAGE	X	X	O	O

## Cluster Object

The following is a feature matrix for DDL which creates/ drops/ alters a cluster object.

**Table 4-12** Feature matrix for cluster object DDL

Object	Feature	2.x	3.x	20c.1	21c.1
Cluster system object	ALTER DATABASE REBALANCE	X	O	O	O
	ALTER DATABASE DROP INACTIVE CLUSTER MEMBERS	X	O	O	O
Cluster group object	CREATE CLUSTER GROUP	X	O	O	O
	DROP CLUSTER GROUP	X	O	O	O
Cluster member object	ALTER CLUSTER GROUP name ADD MEMBER	X	O	O	O
	ALTER CLUSTER GROUP name OFFLINE MEMBER	X	O	O	O
	ALTER DATABASE RESET LOCAL CLUSTER MEMBER	X	O	O	O
	ALTER SYSTEM IRRECOVERABLE CLUSTER MEMBER	X	O	O	O
	ALTER SYSTEM JOIN DATABASE	X	O	O	O
Cluster location object	CREATE CLUSTER LOCATION	X	O	O	O
	DROP CLUSTER LOCATION	X	O	O	O
	ALTER CLUSTER LOCATION	X	O	O	O
Cluster table and shard object	ALTER TABLE name REBALANCE	X	O	O	O
	ALTER TABLE name MERGE SHARDS	X	X	O	O
	ALTER TABLE name MOVE SHARD	X	O	O	O
	ALTER TABLE name SPLIT SHARD	X	O	O	O
	ALTER TABLE name RENAME SHARD	X	O	O	O
Global secondary index object	ALTER TABLE name ADD GLOBAL SECONDARY INDEX	X	O	O	O
	ALTER TABLE name DROP GLOBAL SECONDARY INDEX	X	O	O	O
	ALTER TABLE name ALTER GLOBAL SECONDARY INDEX	X	O	O	O
	ALTER TABLE name REBUILD GLOBAL SECONDARY INDEX	X	X	O	O

## SQL Language

### DML

The following is a feature matrix for DML which manipulates data.

**Table 4-13** Feature matrix for DML

Feature	2.x	3.x	20c.1	21c.1
INSERT INTO ..	O	O	O	O
INSERT INTO .. RETURNING query	O	O	O	O
INSERT INTO .. RETURNING .. INTO ..	O	O	O	O
INSERT INTO .. UPDATE	X	X	X	O
INSERT INTO .. UPDATE .. RETURNING ..	X	X	X	O
INSERT INTO .. UPDATE .. RETURNING .. INTO ..	X	X	X	O
DELETE FROM ..	O	O	O	O
DELETE FROM .. RETURNING query	O	O	O	O
DELETE FROM .. RETURNING .. INTO ..	O	O	O	O
DELETE FROM .. WHERE CURRENT OF cursor	O	O	O	O
UPDATE ..	O	O	O	O
UPDATE .. RETURNING query	O	O	O	O
UPDATE .. RETURNING .. INTO ..	O	O	O	O
UPDATE .. WHERE CURRENT OF cursor	O	O	O	O
CALL proc_name	X	O	O	O

### Query

The following is a feature matrix for SELECT statement which enquires data.

**Table 4-14** Feature matrix for SELECT

Feature	2.x	3.x	20c.1	21c.1
<query expression>	O	O	O	O
<query specification>	O	O	O	O
<select list>	O	O	O	O
<from clause>	O	O	O	O
<joined table>	O	O	O	O
<where clause>	O	O	O	O
<group by clause>	O	O	O	O
<order by clause>	O	O	O	O
<offset limit clause>	O	O	O	O
<set operator>	O	O	O	O
<subquery>	O	O	O	O
<hint clause>	O	O	O	O

Feature	2.x	3.x	20c.1	21c.1
<with clause>	X	X	X	O
<search clause>	X	X	X	O
<cycle clause>	X	X	X	O
<start with clause>	X	X	X	O
<connect by clause>	X	X	X	O
<order siblings by clause>	X	X	X	O

## Control Language

The following is a feature matrix for control statement.

**Table 4-15** Feature matrix for control statement

Control statement	Feature	2.x	3.x	20c.1	21c.1
Transaction	COMMIT	O	O	O	O
	ROLLBACK	O	O	O	O
	SAVEPOINT	O	O	O	O
	RELEASE SAVEPOINT	O	O	O	O
	LOCK TABLE	O	O	O	O
	SET CONSTRAINTS	O	O	O	O
	SET TRANSACTION	O	O	O	O
Session	SET SESSION CHARACTERISTICS AS	O	O	O	O
	SET SESSION AUTHORIZATION	O	O	O	O
	SET SCHEMA	X	X	X	O
	SET TIME ZONE	O	O	O	O
	ALTER SESSION SET property	O	O	O	O
System	ALTER SYSTEM {OPEN MOUNT} DATABASE	O	O	O	O
	ALTER SYSTEM CHECKPOINT	O	O	O	O
	ALTER SYSTEM KILL SESSION	O	O	O	O
	ALTER SYSTEM RECONNECT GLOBAL CONNECTION	X	O	O	O
	ALTER SYSTEM SWITCH LOGFILE	O	O	O	O
	ALTER SYSTEM SET property	O	O	O	O
	ALTER SYSTEM RESET property	O	O	O	O

## PSM Language

The following is a feature matrix for Persistent Stored Module (PSM) language element.

**Table 4-16** Feature matrix for Persistent Stored Module (PSM) language element

Feature	2.x	3.x	20c.1	21c.1
Assignment Statement	X	O	O	O
Basic LOOP Statement	X	O	O	O
Block (BEGIN .. END)	X	O	O	O
CASE Statement	X	O	O	O
CLOSE Statement	X	O	O	O
Collection Method Invocation	X	O	O	O
Collection Variable Declaration	X	O	O	O
CONTINUE Statement	X	O	O	O
Cursor FOR LOOP Statement	X	O	O	O
Cursor Variable Declaration	X	O	O	O
DELETE Statement Extension	X	O	O	O
EXCEPTION_INIT Pragma	X	O	O	O
Exception Declaration	X	O	O	O
Exception Handler	X	O	O	O
EXECUTE IMMEDIATE Statement	X	O	O	O
EXIT Statement	X	O	O	O
Explicit Cursor Declaration and Definition	X	O	O	O
FETCH Statement	X	O	O	O
FOR LOOP Statement	X	O	O	O
GOTO Statement	X	O	O	O
IF Statement	X	O	O	O
Implicit Cursor Attribute	X	O	O	O
INSERT Statement Extension	X	O	O	O
Named Cursor Attribute	X	O	O	O
NULL Statement	X	O	O	O
OPEN Statement	X	O	O	O
OPEN FOR Statement	X	O	O	O
Procedure Call	X	O	O	O
Procedure Declaration and Definition	X	O	O	O
RAISE Statement	X	O	O	O
Record Variable Declaration	X	O	O	O
RETURN Statement	X	O	O	O
RETURNING INTO clause	X	O	O	O
%ROWTYPE Attribute	X	O	O	O
Scalar Variable Declaration	X	O	O	O



Feature	2.x	3.x	20c.1	21c.1
SELECT INTO Statement	X	O	O	O
SQLCODE Function	X	O	O	O
SQLERRM Function	X	O	O	O
%TYPE Attribute	X	O	O	O
UPDATE Statement Extension	X	O	O	O
WHILE LOOP Statement	X	O	O	O

# API

## ODBC

The following is a feature matrix for the ODBC standard API.

**Table 4-17** Feature matrix for the ODBC standard API

Feature	2.x	3.x	20c.1	21c.1
SQLAllocHandle()	O	O	O	O
SQLBindCol()	O	O	O	O
SQLBindParameter()	O	O	O	O
SQLCloseCursor()	O	O	O	O
SQLColAttribute()	O	O	O	O
SQLColumnPrivileges()	O	O	O	O
SQLColumns()	O	O	O	O
SQLConnect()	O	O	O	O
SQLDescribeCol()	O	O	O	O
SQLDescribeParam()	O	O	O	O
SQLDisconnect()	O	O	O	O
SQLDriverConnect()	O	O	O	O
SQLEndTran()	O	O	O	O
SQLExecDirect()	O	O	O	O
SQLExecute()	O	O	O	O
SQLExtendedFetch()	O	O	O	O
SQLFetch()	O	O	O	O
SQLFetchScroll()	O	O	O	O
SQLForeignKeys()	O	O	O	O
SQLFreeHandle()	O	O	O	O
SQLFreeStmt()	O	O	O	O
SQLGetConnectAttr()	O	O	O	O
SQLGetCursorName()	O	O	O	O
SQLGetData()	O	O	O	O
SQLGetDescField()	O	O	O	O
SQLGetDescRec()	O	O	O	O
SQLGetDiagField()	O	O	O	O
SQLGetDiagRec()	O	O	O	O
SQLGetEnvAttr()	O	O	O	O
SQLGetFunctions()	O	O	O	O
SQLGetInfo()	O	O	O	O
SQLGetStmtAttr()	O	O	O	O

Feature	2.x	3.x	20c.1	21c.1
SQLGetTypeInfo()	O	O	O	O
SQLMoreResults()	O	O	O	O
SQLNumParams()	O	O	O	O
SQLNumResultCols()	O	O	O	O
SQLParamData()	O	O	O	O
SQLPrepare()	O	O	O	O
SQLPrimaryKeys()	O	O	O	O
SQLProcedureColumns()	O	O	O	O
SQLProcedures()	O	O	O	O
SQLPutData()	O	O	O	O
SQLRowCount()	O	O	O	O
SQLSetConnectAttr()	O	O	O	O
SQLSetCursorName()	O	O	O	O
SQLSetDescField()	O	O	O	O
SQLSetDescRec()	O	O	O	O
SQLSetEnvAttr()	O	O	O	O
SQLSetPos()	O	O	O	O
SQLSetStmtAttr()	O	O	O	O
SQLSpecialColumns()	O	O	O	O
SQLStatistics()	O	O	O	O
SQLTablePrivileges()	O	O	O	O
SQLTables()	O	O	O	O

The following is a feature matrix for API other than the ODBC standard API.

**Table 4-18** Feature matrix for API other than the ODBC standard

Feature	2.x	3.x	20c.1	21c.1
xa_open	O	O	O	O
xa_close	O	O	O	O
xa_start	O	O	O	O
xa_end	O	O	O	O
xa_rollback	O	O	O	O
xa_prepare	O	O	O	O
xa_commit	O	O	O	O
xa_recover	O	O	O	O
xa_forget	O	O	O	O
SQLGetXaSwitch	O	O	O	O
SQLGetXaConnectionHandle	O	O	O	O
SQLGetGroupCount	X	O	O	O
SQLGetGroupIDs	X	O	O	O

Feature	2.x	3.x	20c.1	21c.1
SQLGetGroupName	X	O	O	O
SQLGetSuitableGroupID	X	O	O	O

## JDBC

The following is a class feature matrix for JDBC.

**Table 4-19** Class feature matrix for JDBC

Feature	2.x	3.x	20c.1	21c.1
CallableStatement	X	O	O	O
CommonDataSource	O	O	O	O
Connection	O	O	O	O
ConnectionPoolDataSource	O	O	O	O
DatabaseMetaData	O	O	O	O
DataSource	O	O	O	O
Driver	O	O	O	O
ParameterMetaData	O	O	O	O
PooledConnection	O	O	O	O
PreparedStatement	O	O	O	O
ResultSet	O	O	O	O
ResultSetMetaData	O	O	O	O
RowId	O	O	O	O
Savepoint	O	O	O	O
Statement	O	O	O	O
XAConnection	O	O	O	O
XADataSource	O	O	O	O
XAResource	O	O	O	O
GoldilocksInterval	O	O	O	O
GoldilocksTypes	O	O	O	O

## Embedded SQL

### Precompiler Option

The following is a feature matrix for precompiler option.

**Table 4-20** Feature matrix for precompiler option

Feature	2.x	3.x	20c.1	21c.1
--help	O	O	O	O
--include-path	O	O	O	O
--no-prompt	O	O	O	O
--output	O	O	O	O
--unsafe-null	O	O	O	O
--version	O	O	O	O
--no-lineinfo	X	O	O	O
--char_map	X	O	O	O
--cumulative	X	X	O	O
--autocommit	X	X	X	O

### Embedded SQL-only Syntax

The following is a feature matrix of embedded SQL-only syntax.

**Table 4-21** Feature matrix for embedded SQL-only syntax

Feature	2.x	3.x	20c.1	21c.1
EXEC SQL AT	O	O	O	O
EXEC SQL ATOMIC INSERT	O	O	O	O
EXEC SQL AUTOCOMMIT	O	O	O	O
EXEC SQL BEGIN DECLARE SECTION	O	O	O	O
EXEC SQL COMMIT RELEASE	O	O	O	O
EXEC SQL CONNECT	O	O	O	O
EXEC SQL CONTEXT ALLOCATE	O	O	O	O
EXEC SQL CONTEXT FREE	O	O	O	O
EXEC SQL CONTEXT USE	O	O	O	O
EXEC SQL DISCONNECT	O	O	O	O
EXEC SQL END DECLARE SECTION	O	O	O	O
EXEC SQL FOR	O	O	O	O
EXEC SQL GET GROUPID	X	O	O	O
EXEC SQL INCLUDE	O	O	O	O
EXEC SQL INCLUDE SQLCA	O	O	O	O
EXEC SQL OPTION	O	O	O	O
EXEC SQL ROLLBACK RELEASE	O	O	O	O

Feature	2.x	3.x	20c.1	21c.1
EXEC SQL WHENEVER	0	0	0	0

## Host Variable Data Type

The following is a feature matrix for embedded SQL data type which can be used for HOST variables.

**Table 4-22** Feature matrix for host variable data type

Feature	2.x	3.x	20c.1	21c.1
C native type	0	0	0	0
struct, union	0	0	0	0
typedef	0	0	0	0
VARCHAR	0	0	0	0
LONG VARCHAR	0	0	0	0
BINARY	0	0	0	0
LONG VARBINARY	0	0	0	0
BOOLEAN	0	0	0	0
NUMBER	0	0	0	0
DATE	0	0	0	0
TIME	0	0	0	0
TIME WITH TIMEZONE	0	0	0	0
TIMESTAMP	0	0	0	0
TIMESTAMP WITH TIMEZONE	0	0	0	0
INTERVAL YEAR	0	0	0	0
INTERVAL MONTH	0	0	0	0
INTERVAL DAY	0	0	0	0
INTERVAL HOUR	0	0	0	0
INTERVAL MINUTE	0	0	0	0
INTERVAL SECOND	0	0	0	0
INTERVAL YEAR TO MONTH	0	0	0	0
INTERVAL DAY TO HOUR	0	0	0	0
INTERVAL DAY TO MINUTE	0	0	0	0
INTERVAL DAY TO SECOND	0	0	0	0
INTERVAL HOUR TO MINUTE	0	0	0	0
INTERVAL HOUR TO SECOND	0	0	0	0
INTERVAL MINUTE TO SECOND	0	0	0	0

## Dynamic SQL

The following is a feature matrix for dynamic SQL.

**Table 4-23** Feature matrix for dynamic SQL

Feature	2.x	3.x	20c.1	21c.1
SELECT .. INTO	O	O	O	O
EXECUTE IMMEDIATE sql	O	O	O	O
PREPARE stmt	O	O	O	O
EXECUTE stmt	O	O	O	O
DECLARE cursor FOR sql	O	O	O	O
DECLARE cursor FOR stmt	O	O	O	O
OPEN cursor	O	O	O	O
OPEN cursor USING	O	O	O	O
FETCH cursor INTO	O	O	O	O
CLOSE cursor	O	O	O	O
DELETE .. WHERE CURRENT OF cursor	O	O	O	O
UPDATE .. WHERE CURRENT OF cursor	O	O	O	O



## PyDBC

### Module

The following is a method feature matrix for pygoldilocks provided by PyDBC.

**Table 4-24** Feature matrix for pygoldilock method

Feature	2.x	3.x	20c.1	21c.1
connect	X	O	O	O
Date	X	O	O	O
Time	X	O	O	O
Timestamp	X	O	O	O
DateFromTicks	X	O	O	O
TimeFromTicks	X	O	O	O
TimestampFromTicks	X	O	O	O
Binary	X	O	O	O
STRING	X	O	O	O
BINARY	X	O	O	O
NUMBER	X	O	O	O
DATETIME	X	O	O	O
ROWID	X	O	O	O
getDecimalSeparator	X	O	O	O
setDecimalSeparator	X	O	O	O

The following is an attribute feature matrix for pygoldilocks module.

**Table 4-25** Feature matrix for pygoldilock attribute

Feature	2.x	3.x	20c.1	21c.1
apilevel	X	O	O	O
threadsafety	X	O	O	O
paramstyle	X	O	O	O
version	X	O	O	O
lowercase	X	O	O	O

### Connection

The following is a method feature matrix for connection object.

**Table 4-26** Feature matrix for connection method

Feature	2.x	3.x	20c.1	21c.1
cursor	X	O	O	O
commit	X	O	O	O

Feature	2.x	3.x	20c.1	21c.1
rollback	X	O	O	O
close	X	O	O	O
getinfo	X	O	O	O
execute	X	O	O	O
set_attr	X	O	O	O

The following is an attribute feature matrix for connection object.

**Table 4-27** Feature matrix for connection attribute

Feature	2.x	3.x	20c.1	21c.1
autocommit	X	O	O	O
searchescape	X	O	O	O
timeout	X	O	O	O

## Cursor

The following is a method feature matrix for cursor object.

**Table 4-28** Feature matrix for cursor method

Feature	2.x	3.x	20c.1	21c.1
excute	X	O	O	O
executemany	X	O	O	O
fetchone	X	O	O	O
fetchall	X	O	O	O
fetchmany	X	O	O	O
commit	X	O	O	O
rollback	X	O	O	O
skip	X	O	O	O
nextset	X	O	O	O
close	X	O	O	O
setinputsizes	X	O	O	O
setoutputsize	X	O	O	O
callproc	X	O	O	O
callfunc	X	O	O	O
tables	X	O	O	O
columns	X	O	O	O
statistics	X	O	O	O
rowIdColumns	X	O	O	O
rowVerColumns	X	O	O	O
primaryKeys	X	O	O	O

Feature	2.x	3.x	20c.1	21c.1
foreignKeys	X	O	O	O
procedures	X	O	O	O
getTypeInfo	X	O	O	O

The following is an attribute feature matrix for cursor object.

**Table 4-29** Feature matrix for cursor attribute

Feature	2.x	3.x	20c.1	21c.1
Description	X	O	O	O
rowcount	X	O	O	O
arraysize	X	O	O	O
connection	X	O	O	O
fast_executemany	X	O	O	O

## Row

The following is an attribute feature matrix for row object.

**Table 4-30** Feature matrix for row attribute

Feature	2.x	3.x	20c.1	21c.1
cursor_description	X	O	O	O

## Utility

### gcreatedb

#### Command Usage

The following is a feature matrix for command usage of gcreatedb.

**Table 4-31** Feature matrix for command usage of gcreatedb

Feature	2.x	3.x	20c.1	21c.1
--character_set	O	O	O	O
--char_length_units	O	O	O	O
--cluster	X	O	O	O
--db_comment	O	O	O	O
--help	O	O	O	O
--host	X	O	O	O
--member	X	O	O	O
--port	X	O	O	O
--silent	O	O	O	O
--timezone	O	O	O	O

## glsnr

### Command Usage

The following is a feature matrix for command usage of glsnr.

**Table 4-32** Feature matrix for command usage of glsnr

Feature	2.x	3.x	20c.1	21c.1
--help	O	O	O	O
--home	X	O	O	O
--silent	O	O	O	O
--start	O	O	O	O
--status	O	O	O	O
--stop	O	O	O	O

### Configuration File

The following is a feature matrix for configuration of glsnr.

**Table 4-33** Feature matrix for configuration of glsnr

Feature	2.x	3.x	20c.1	21c.1
BACKLOG	O	O	O	O
DEFAULT_CS_MODE	O	O	O	O
LISTENER_LOG_DIR	X	O	O	O
LISTEN_PORT	O	O	O	O
TCP_EXCLUDED	O	O	O	O
TCP_INVITED	O	O	O	O
TCP_HOST	O	O	O	O
TCP_VALIDNODE_CHECKING	O	O	O	O
TIMEOUT	O	O	O	O
USR_DIR	X	O	O	O

## gsql/ gsqlnet

### Command Usage

The following is a feature matrix for command usage of gsql.

**Table 4-34** Feature matrix for command usage of gsql

Feature	2.x	3.x	20c.1	21c.1
username password	O	O	O	O
--as {SYSDBA ADMIN}	O	O	O	O
--conn-string	O	O	O	O
--dsn	O	O	O	O
--enable-color	O	O	O	O
--help	O	O	O	O
--import	O	O	O	O
--no-prompt	O	O	O	O
--prompt	O	O	O	O
--silent	O	O	O	O
--version	O	O	O	O

### Interactive gsql Command

The following is a feature matrix for interactive gsql command which is used in gsql prompt state.

**Table 4-35** Feature matrix for interactive gsql command

Feature	2.x	3.x	20c.1	21c.1
\\	O	O	O	O
\connect userid password [as sysdba]	O	O	O	O
\cshutdown	X	O	O	O
\cstartup	X	O	O	O
\ddl_cluster	X	O	O	O
\ddl_db	O	O	O	O
\ddl_tablespace	O	O	O	O
\ddl_profile	O	O	O	O
\ddl_audit_policy	X	O	O	O
\ddl_auth	O	O	O	O
\ddl_schema	O	O	O	O
\ddl_public_synonym	O	O	O	O
\ddl_table	O	O	O	O
\ddl_constraint	O	O	O	O
\ddl_index	O	O	O	O
\ddl_view	O	O	O	O

Feature	2.x	3.x	20c.1	21c.1
\ddl_sequence	O	O	O	O
\ddl_synonym	O	O	O	O
\ddl_procedure	X	O	O	O
\ddl_package	X	O	O	O
\desc	O	O	O	O
\dynamic sql :var	O	O	O	O
\exec	O	O	O	O
\exec :var := :value	O	O	O	O
\exec sql	O	O	O	O
\explain plan [on only]	O	O	O	O
\help	O	O	O	O
\history	O	O	O	O
\host {os_command}	X	O	O	O
\import	O	O	O	O
\idesc	O	O	O	O
\{n}	O	O	O	O
\prepare sql	O	O	O	O
\print	O	O	O	O
\quit	O	O	O	O
\set autocommit	O	O	O	O
\set color	O	O	O	O
\set colsize	O	O	O	O
\set ddlsize	O	O	O	O
\set error	O	O	O	O
\set history	O	O	O	O
\set linesize	O	O	O	O
\set numsize	O	O	O	O
\set pagesize	O	O	O	O
\set timing	O	O	O	O
\set vertical	O	O	O	O
\shutdown {abort immediate transactional normal}	O	O	O	O
\startup {nomount mount open}	O	O	O	O
\var	O	O	O	O

## gloader/ gloadernet

### Command Usage

The following is a feature matrix for command usage of gloader.

**Table 4-36** Feature matrix for command usage of gloader

Feature	2.x	3.x	20c.1	21c.1
username password	O	O	O	O
--array	O	O	O	O
--atomic	O	O	O	O
--bad	O	O	O	O
--buffered	O	O	O	O
--commit	O	O	O	O
--control	O	O	O	O
--data	O	O	O	O
--dsn	O	O	O	O
--errors	O	O	O	O
--export	O	O	O	O
--fieldterm	X	O	O	O
--filesize	O	O	O	O
--format	O	O	O	O
--help	O	O	O	O
--import	O	O	O	O
--lineterm	X	O	O	O
--log	O	O	O	O
--no-prompt	O	O	O	O
--parallel	O	O	O	O
--propagation	O	O	O	O
--qualifier	X	O	O	O
--silent	O	O	O	O
--AsTIMESTAMP	O	O	O	O
--where	X	O	O	O
--group-id	X	O	O	O
--directio-size	X	O	O	O

### Control File Syntax

The following is a feature matrix for control file syntax of gloader.



**Table 4-37** Feature matrix for control file syntax of gloder

Feature	2.x	3.x	20c.1	21c.1
CHARACTERSET	O	O	O	O
FIELDS TERMINATED BY	O	O	O	O
OPTIONALLY ENCLOSED BY	O	O	O	O
TABLE table_name	O	O	O	O
TABLE schema_name.table_name	O	O	O	O
LTRIM	X	O	O	O
RTRIM	X	O	O	O
LINES TERMINATED BY	X	O	O	O
WHERE	X	O	O	O

## gdump

### Command Usage

The following is a feature matrix for command usage of gdump.

**Table 4-38** Feature matrix for command usage of gdump

Item	Feature	2.x	3.x	20c.1	21c.1	
Common arguments	--silent	O	O	O	O	
File type	BACKUP	O	O	O	O	
	COMMIT_LOG	X	O	O	O	
	CONTROL	O	O	O	O	
	DATA	O	O	O	O	
	LOG	O	O	O	O	
	LOG_BUFFER	X	O	O	O	
	PEND_BUFFER	X	O	O	O	
BACKUP file arguments	PROPERTY	O	O	O	O	
	--body	O	O	O	O	
	--tbs	O	O	O	O	
	--number	O	O	O	O	
CONTROL file arguments	--fetch	O	O	O	O	
	--section	O	O	O	O	
	DATA file arguments	--header	O	O	O	O
		--number	O	O	O	O
--fetch		O	O	O	O	
LOG file arguments	--all	X	O	O	O	
	--fetch	O	O	O	O	
	--header	X	O	O	O	
	--number	O	O	O	O	
	--offset	O	O	O	O	

# tablediff

## Configuration File

The following is a feature matrix for configuration file of tablediff.

**Table 4-39** Feature matrix for configuration file of tablediff

Item	Feature	2.x	3.x	20c.1	21c.1
Source table	SOURCE_PASSWORD	○	○	○	○
	SOURCE_SCHEMA	○	○	○	○
	SOURCE_TABLE	○	○	○	○
	SOURCE_URL	○	○	○	○
	SOURCE_USER	○	○	○	○
Target table	TARGET_PASSWORD	○	○	○	○
	TARGET_SCHEMA	○	○	○	○
	TARGET_TABLE	○	○	○	○
	TARGET_URL	○	○	○	○
	TARGET_USER	○	○	○	○
Sync operation	TARGET_INSERT	○	○	○	○
	TARGET_UPDATE	○	○	○	○
	TARGET_DELETE	○	○	○	○
	SOURCE_INSERT	○	○	○	○
Operation options	DIFF_BIN_FILE	○	○	○	○
	DIFF_OUT_FILE	○	○	○	○
	DISPLAY_CALL_STACK	○	○	○	○
	DISPLAY_ROW_UNIT	○	○	○	○
	EXCLUDE_COLUMNS	○	○	○	○
	LOGGING_ON_DIFF	○	○	○	○
	LOGGING_ON_SUCCESS	○	○	○	○
	JOB_QUEUE_SIZE	○	○	○	○
	JOB_THREAD	○	○	○	○
	JOB_UNIT_SIZE	○	○	○	○
	PARTITION_RANGE	○	○	○	○
	SYNC_OUT_FILE	○	○	○	○
WHERE_CLAUSE	○	○	○	○	

## gsyncher

### Command Usage

The following is a feature matrix for command usage of gsyncher.

**Table 4-40** Feature matrix for command usage of gsyncher

Feature	2.x	3.x	20c.1	21c.1
--log	O	O	O	O
--silent	O	O	O	O
--home	X	O	O	O
--copy-right	O	O	O	O
--backup-path	O	O	O	O
--help	O	O	O	O

## gmon

### Command Usage

The following is a feature matrix for command usage of gmon.

**Table 4-41** Feature matrix for command usage of gmon

Feature	2.x	3.x	20c.1	21c.1
--start	X	O	O	O
--stop	X	O	O	O
--status	X	O	O	O
--home	X	O	O	O
--uds_dir	X	X	O	O
--silent	X	O	O	O
--no-copyright	X	O	O	O
--help	X	O	O	O

## gtrclogger

### Command Usage

The following is a feature matrix for command usage of gtrclogger.

**Table 4-42** Feature matrix for command usage of gtrclogger

Feature	2.x	3.x	20c.1	21c.1
--dir	X	O	O	O
--help	X	O	O	O
--port	X	O	O	O
--start	X	O	O	O
--stop	X	O	O	O

## glocator

### Command Usage

The following is a feature matrix for command usage of glocator.

**Table 4-43** Feature matrix for command usage of glocator

Feature	2.x	3.x	20c.1	21c.1
--create	X	O	O	O
--start	X	O	O	O
--stop	X	O	O	O
--conf	X	O	O	O
--status	X	O	O	O
--sync	X	O	O	O
--silent	X	O	O	O
--no-copyright	X	O	O	O
--help	X	O	O	O

### Configuration File

The following is a feature matrix for configuration file of glocator.

**Table 4-44** Feature matrix for configuration file of glocator

Feature	2.x	3.x	20c.1	21c.1
PORT	X	O	O	O
WORKER_COUNT	X	O	O	O
SESSION_QUEUE_SIZE	X	O	O	O
SESSION_ALLOCATOR_SIZE	X	O	O	O
PACKET_ALLOCATOR_SIZE	X	O	O	O
SYSTEM_LOGGER_DIR	X	O	O	O
SYSTEM_UDS_DIR	X	O	O	O
LOCATION_FILE_DIR	X	O	O	O
LOCATION_FILE_SIZE	X	O	O	O
LOCATION_FILE_MAX_SIZE	X	O	O	O
SESSION_TIMEOUT	X	O	O	O
FAILOVER_TIMEOUT	X	O	O	O
ALTERNATE_LOCATORS	X	O	O	O
SYNC_RETRY_COUNT	X	O	O	O
SYNC_RESPONSE_TIMEOUT	X	O	O	O

## gagent

### Command Usage

The following is a feature matrix for command usage of gagent.

**Table 4-45** Feature matrix for command usage of gagent

Feature	2.x	3.x	20c.1	21c.1
--start	X	O	O	O
--stop	X	O	O	O
--conf	X	O	O	O
--status	X	O	O	O
--home	X	O	O	O
--silent	X	O	O	O
--no-copyright	X	O	O	O
--help	X	O	O	O

### Configuration File

The following is a feature matrix for configuration file of gagent.

**Table 4-46** Feature matrix for configuration file of gagent

Feature	2.x	3.x	20c.1	21c.1
PORT	X	O	O	O
LOCATOR_HOST	X	O	O	O
LOCATOR_PORT	X	O	O	O
COMMAND_QUEUE_SIZE	X	O	O	O
COMMAND_ALLOCATOR_SIZE	X	O	O	O
PACKET_ALLOCATOR_SIZE	X	O	O	O
SYSTEM_LOGGER_DIR	X	O	O	O
SESSION_TIMEOUT	X	O	O	O
UPDATE_LOCATION_TIME	X	O	O	O
ALTERNATE_LOCATORS	X	O	O	O



# gloctl

## Command Usage

The following is a feature matrix for command usage of gloctl.

**Table 4-47** Feature matrix for command usage of gloctl

Feature	2.x	3.x	20c.1	21c.1
--dsn	X	X	X	X
--conf	X	O	O	O
--ip	X	O	O	O
--port	X	O	O	O
--import	X	O	O	O
--silent	X	O	O	O
--no-copyright	X	O	O	O
--help	X	O	O	O

## Configuration File

The following is a feature matrix for configuration file of gloctl.

**Table 4-48** Feature matrix for configuration file of gloctl

Feature	2.x	3.x	20c.1	21c.1
PORT	X	O	O	O
LOCATOR_HOST	X	O	O	O
LOCATOR_PORT	X	O	O	O

# Replication

## cyclone

### Command Usage

The following is a feature matrix for command usage of cyclone.

**Table 4-49** Feature matrix for command usage of cyclone

Feature	2.x	3.x	20c.1	21c.1
--conf	O	O	O	O
--encrypt	X	O	O	O
--group	O	O	O	O
--help	O	O	O	O
--key	X	O	O	O
--master	O	O	O	O
--reset	O	O	O	O
--silent	O	O	O	O
--slave	O	O	O	O
--start	O	O	O	O
--status	O	O	O	O
--stop	O	O	O	O
--sync	O	O	O	O
--stand-alone	X	O	O	O
--recovery	X	O	O	O
--local	X	O	O	O

### Configuration File

The following is a feature matrix for configuration file of cyclone.

**Table 4-50** Feature matrix for configuration file of cyclone

Configuration	Feature	2.x	3.x	20c.1	21c.1
Common configuration	COMM_CHUNK_COUNT	O	O	O	O
	DSN	O	O	O	O
	USER_ENCRYPT_PW	X	O	O	O
	GROUP_NAME	O	O	O	O
	HOST_IP	O	O	O	O
	HOST_EXTERNAL_IP	X	O	O	O
	HOST_PORT	O	O	O	O
	PORT	O	O	O	O

Configuration	Feature	2.x	3.x	20c.1	21c.1
	PROTOCOL	X	O	O	O
	USER_ID	O	O	O	O
	USER_PW	O	O	O	O
MASTER configuration	CAPTURE_TABLE	O	O	O	O
	LOG_PATH	O	O	O	O
	READ_LOG_BLOCK_COUNT	O	O	O	O
	TRANS_SORT_AREA_SIZE	O	O	O	O
	TRANS_FILE_PATH	O	O	O	O
	SYNCHER_COUNT	O	O	O	O
	SYNC_ARRAY_SIZE	O	O	O	O
	GIVEUP_INTERVAL	O	O	O	O
	LOG_CAPTURE_INTERVAL_1	X	O	O	O
LOG_CAPTURE_INTERVAL_2	X	O	O	O	
SLAVE configuration	APPLIER_COUNT	O	O	O	O
	APPLY_ARRAY_SIZE	O	X	X	X
	APPLY_COMMIT_SIZE	O	O	O	O
	APPLY_TABLE	O	O	O	O
	MASTER_IP	O	O	O	O
	PROPAGATE_MODE	O	O	O	O
	CLUSTER	X	O	O	O
ORACLE_DRIVER	X	O	O	O	

## logmirror

### Command Usage

The following is a feature matrix for command usage of logmirror.

**Table 4-51** Feature matrix for command usage of logmirror

Feature	2.x	3.x	20c.1	21c.1
--conf	O	O	O	O
--help	O	O	O	O
--infiniband	O	O	O	O
--master	O	O	O	O
--silent	O	O	O	O
--slave	O	O	O	O
--start	O	O	O	O
--stop	O	O	O	O

### Configuration File

The following is a feature matrix for configuration file of logmirror.

**Table 4-52** Feature matrix for configuration file of logmirror

Configuration	Feature	2.x	3.x	20c.1	21c.1
Common configuration	PORT	O	O	O	O
MASTER configuration	DSN	O	O	O	O
	HOST_IP	O	O	O	O
	HOST_PORT	O	O	O	O
	PROTOCOL	X	O	O	O
	USER_ID	O	O	O	O
SLAVE configuration	USER_PW	O	O	O	O
	LOG_PATH	O	O	O	O
	MASTER_IP	O	O	O	O

## cymon

### Command Usage

The following is a feature matrix for command usage of cymon.

**Table 4-53** Feature matrix for command usage of cymon

Feature	2.x	3.x	20c.1	21c.1
--conf	O	O	O	O
--help	O	O	O	O
--cycle	O	O	O	O
--key	X	O	O	O
--start	O	O	O	O
--stop	O	O	O	O
--status	O	O	O	O

## cyfile

### Command Usage

The following is a feature matrix for command usage of cyfile.

**Table 4-54** Feature matrix for command usage of cyfile

Feature	2.x	3.x	20c.1	21c.1
--conf	X	X	O	O
--help	X	X	O	O
--reset	X	X	O	O
--key	X	X	O	O
--silent	X	X	O	O
--info	X	X	O	O
--start	X	X	O	O
--stop	X	X	O	O
--group	X	X	O	O
--encrypt	X	X	O	O
--status	X	X	O	O

### Configuration File

The following is a feature matrix for configuration file of cyfile.

**Table 4-55** Feature matrix for configuration file of cyfile

Feature	2.x	3.x	20c.1	21c.1
DSN	X	X	O	O
HOST_IP	X	X	O	O
HOST_PORT	X	X	O	O
PROTOCOL	X	X	O	O
USER_ID	X	X	O	O
USER_PW	X	X	O	O
GROUP_NAME	X	X	O	O
USER_ENCRYPT_PW	X	X	O	O
CAPTURE_TABLE	X	X	O	O
READ_LOG_BLOCK_COUNT	X	X	O	O
TRANS_SORT_AREA_SIZE	X	X	O	O
TRANS_FILE_PATH	X	X	O	O
LOG_CAPTURE_INTERVAL_1	X	X	O	O
LOG_CAPTURE_INTERVAL_2	X	X	O	O
DATA_FILE_PATH	X	X	O	O
DATA_FILE_PREFIX	X	X	O	O

Feature	2.x	3.x	20c.1	21c.1
DATA_FILE_SIZE	X	X	O	O
UPDATE_BEFORE_VALUE	X	X	O	O

## 4.2 What's New in GOLDILOCKS 21c.1

This chapter briefly describes the features added to GOLDILOCKS 21c.1.

### Architecture

#### System Architecture

It has not been changed.

#### Storage Internal

It has not been changed.

#### Transaction Control

It has not been changed.

#### Backup & Recovery

It has not been changed.

#### Database Information

##### DICTIONARY\_SCHEMA

It has not been changed.

##### INFORMATION\_SCHEMA

It has not been changed.

##### PERFORMANCE\_VIEW\_SCHEMA

V\$PLAN\_HISTORY view has been added, and it retrieves plans managed by the plan history feature.

V\$PLAN\_HISTORY\_LATEST view has been added, and it retrieves the latest plan managed by the plan history feature.



## Server Property

**MAXIMUM\_PACKAGE\_INSTANCE\_COUNT** property has been added, and it controls the number of package instances available in the session.

**MAXIMUM\_FILE\_CACHE\_SIZE** property has been added, and it controls the maximum number of file caches available in the session.

**MAXIMUM\_FLUSH\_BUFFER\_PAGE\_COUNT** property has been added, and it controls the maximum number of pages to be written in the disk per a writing operation when IO thread records the updated pages in the buffer into the disk.

**BUFFER\_PREFETCH\_PAGE\_COUNT** property has been added, and it controls the maximum number of pages to be prefetched per a disk IO when the session accesses to the page in the disk tablespace which does not exist in the buffer.

**PLAN\_HISTORY** property has been added, and it sets whether to use the plan history.

**PLAN\_HISTORY\_SIZE** property has been added, and it controls the number of plans to be stored in the plan history.

**BROADCAST\_INDEX\_REBUILD\_PROTOCOL** property has been added, and it sets whether to simultaneously rebuild the indexes on all members when rebuilding the index in cluster environment.

**TIMER\_INTERVAL** property has been added, and it sets the time interval which is required when the timer thread sets the system time.

The default value of **DEFAULT\_INDEX\_PCTFREE** has been changed to 10.

The default value of **DEFAULT\_MAXTRANS** has been changed to 32.

**INST\_HASH\_TABLE\_BUCKET\_MAX\_COUNT** property has been added to set the maximum expected bucket counts of the hash instant table.

**INDEX\_LOGGING\_THROTTLING** property has been added to control the logging speed during index creation and rebuild operations.

# SQL

## SQL Element

### Data Type

It has not been changed.

### Function

FROM\_TZ function has been added.

The following **<hierarchy expression>**s which are used together with CONNECT BY clause have been added.

- LEVEL
- CONNECT\_BY\_ISCYCLE
- CONNECT\_BY\_ISLEAF
- PRIOR expr
- CONNECT\_BY\_ROOT expr
- SYS\_CONNECT\_BY\_PATH( expr, 'string' )

## Object

### SQL Object

It has not been changed.

### Cluster Object

It has not been changed.

## SQL Language

### DML

Upsert statements have been added.

- INSERT INTO name ... UPDATE
- INSERT INTO name ... UPDATE RETURNING
- INSERT INTO name ... UPDATE RETURNING ... INTO

## Query

### WITH Clause

Common Table Expression (CTE) feature using WITH clause has been added.

- Common Table Expression (CTE)
- with clause
- < cte query hints >

### Hierarchy Query

Hierarchy query feature has been added.

- Hierarchical Query
- hierarchical query clause

## Control Language

### SET SCHEMA

SET SCHEMA schema\_name statement which can alter the default schema of the current session has been added.

## PSM Language

It has not been changed.

## API

### ODBC

PREFER\_IPV6 has been added to **Keywords in the data source specification section**.

DOT\_NET\_FOR\_ODBC has been added to **Keywords in the data source specification section**.

### JDBC

It supports some **Blob** and **Clob**.

prefer\_ipv6 and locality\_on\_demand have been added to **Connection property**.

**Statement Pooling** feature has been added.

It supports **getNetworkTimeout**, **setNetworkTimeout** methods of **Connection** class.

## Embedded SQL

### Precompiler Option

--autocommit has been added.

### Embedded SQL-only Statement

gpec supports **Declaring Function Argument**.

### Host Variable Data Type

It has not been changed.

### Dynamic SQL

It has not been changed.

### PDO

It has not been changed.

### PyDBC

It has not been changed.

## **Ruby**

It has not been changed.

## **Hibernate**

It has not been changed.

## Utility

### **gcreatedb**

It has not been changed.

### **glsnr**

It supports IPv6.

### **gsqI/gsqInet**

It has not been changed.

### **gloader/gloadernet**

The binary file structure has been changed.

### **gdump**

It has not been changed.

### **tablediff**

It has not been changed.

### **gsyncher**

It has not been changed.

### **gmon**

It has not been changed.

### **gtrclogger**

It has not been changed.

## **glocator**

It has not been changed.

## **gagent**

It has not been changed.

## **gloctl**

It has not been changed.

## Replication

### **cyclone**

IBM DB2 database has been added as an interworking target database while operating CYCLONE.

### **logmirror**

It has not been changed.

### **cymon**

It has not been changed.

### **cyfile**

A tool which uses CDC method to store/ record the transaction of the original database in CSV format file has been added.



## 4.3 Patch Notes

### 21c.1.30 Patch Notes

**ISSUE-6358** A cache coherency issue occurred on the weak memory ordering device, and this error has been fixed.

#### Description

A memory access order discrepancy, where the order deviated from the program order, occurred on the weak memory ordering device, causing the server to terminate abnormally. This error has been fixed.

#### Symptom

Using old data from the CPU cache instead of the latest data in memory can cause the server to malfunction or terminate abnormally.

#### Workaround

The patch is required.

**ISSUE-6557** When using an outer join, if functions such as DECODE, stored functions, or CONCAT that include columns from the right table are in the WHERE clause, it can lead to incorrect results.

#### Description

When functions such as DECODE, stored functions, or CONCAT that include columns from the right table exist in the WHERE clause, the following outer join operation elimination should not be applied; however, it was actually applied, resulting in an error.

- The left outer join was transformed into an inner join.
- The full outer join was transformed into a left outer join.

#### Symptom

In cases where outer join operation elimination occurs as follows, the inclusion of DECODE, stored functions, etc., in the WHERE clause can lead to incorrect results.

Before the modification, the following incorrect results were output.

```

CREATE TABLE t1 ( c1 INTEGER, c2 INTEGER );
INSERT INTO t1 VALUES(1,1);
INSERT INTO t1 VALUES(2,2);
CREATE TABLE t2 ( c1 INTEGER, c2 INTEGER );
INSERT INTO t2 VALUES(1,1);
COMMIT;
gSQL> \EXPLAIN PLAN
SELECT t1.c1, t2.c1
   FROM t1 LEFT OUTER JOIN t2
   ON t1.c1 = t2.c1
 WHERE DECODE( t2.c2, NULL, 'A', 'B' ) = 'A'
;
no rows selected.
>>> start print plan
< Execution Plan >
=====
|  IDX  |  NODE DESCRIPTION  |
-----|-----|
|   0   |  SELECT STATEMENT  |
|   1   |    QUERY BLOCK ("SQB_IDX_2")  |
|   2   |     HASH JOIN (INNER JOIN)  |
|   3   |      TABLE ACCESS ("T1")  |
|   4   |      HASH JOIN INSTANT  |
|   5   |      TABLE ACCESS ("T2")  |
=====
1 - TARGET : T1.C1, T2.C1
2 - JOINED COLUMN : T1.C1, T2.C1
3 - READ COLUMN : T1.C1
4 - HASH KEY : T2.C1
   READ KEY COLUMN : T2.C1
   HASH FILTER : T2.C1 = T1.C1
5 - READ COLUMN : T2.C1, T2.C2
   LOGICAL FILTER : DECODE(T2.C2,NULL,'A','B') = 'A'
<<< end print plan

```

After the modification, the correct plan and results are as follows.

```

\EXPLAIN PLAN
SELECT t1.c1, t2.c1
   FROM t1 LEFT OUTER JOIN t2
   ON t1.c1 = t2.c1

```

```

WHERE DECODE( t2.c2, NULL, 'A', 'B' ) = 'A'
;
C1    C1
-- ----
      2 null
1 row selected.
>>> start print plan
< Execution Plan >

=====
|  IDX  |  NODE DESCRIPTION                               |
-----|-----|
|    0  |  SELECT STATEMENT                               |
|    1  |    QUERY BLOCK ("SQB_IDX_2")                   |
|    2  |      HASH JOIN (LEFT OUTER JOIN)              |
|    3  |        TABLE ACCESS ("T1")                   |
|    4  |          HASH JOIN INSTANT                     |
|    5  |            TABLE ACCESS ("T2")               |
=====

1 - TARGET : T1.C1, T2.C1
2 - JOINED COLUMN : T2.C2, T1.C1, T2.C1
   WHERE FILTER : DECODE(T2.C2,NULL,'A','B') = 'A'
3 - READ COLUMN : T1.C1
4 - HASH KEY : T2.C1
   RECORD COLUMN : T2.C2
   READ KEY COLUMN : T2.C1, T2.C2
   HASH FILTER : T2.C1 = T1.C1
5 - READ COLUMN : T2.C1, T2.C2
<<< end print plan

```

## Workaround

Use the NO\_QUERY\_TRANSFORMATION hint as follows.

```

\EXPLAIN PLAN
SELECT /*+ NO_QUERY_TRANSFORMATION */
      t1.c1, t2.c1
FROM t1 LEFT OUTER JOIN t2
      ON t1.c1 = t2.c1
WHERE DECODE( t2.c2, NULL, 'A', 'B' ) = 'A'
;
C1    C1
-- ----

```

```

2 null
1 row selected.
>>> start print plan
< Execution Plan >
=====
|  IDX  |  NODE DESCRIPTION          |
-----|-----|
|   0   |  SELECT STATEMENT          |
|   1   |    QUERY BLOCK ("QB_IDX_2") |
|   2   |      HASH JOIN (LEFT OUTER JOIN) |
|   3   |        TABLE ACCESS ("T1") |
|   4   |          HASH JOIN INSTANT |
|   5   |            TABLE ACCESS ("T2") |
=====
1 - TARGET : T1.C1, T2.C1
2 - JOINED COLUMN : T2.C2, T1.C1, T2.C1
   WHERE FILTER : DECODE(T2.C2,NULL,'A','B') = 'A'
3 - READ COLUMN : T1.C1
4 - HASH KEY : T2.C1
   RECORD COLUMN : T2.C2
   READ KEY COLUMN : T2.C1, T2.C2
   HASH FILTER : T2.C1 = T1.C1
5 - READ COLUMN : T2.C1, T2.C2
<<< end print plan

```

**ISSUE-6537** When performing a cast operation between string types, such as `CAST('ABCDE' AS CHAR(3))`, an error occurs if the source value exceeds the dest precision.

## Description

When performing a cast operation between string types, such as `CAST('ABCDE' AS CHAR(3))`, an error occurs if the source value exceeds the dest precision.

In this case, the cast operation is performed by truncating the source value to match the precision of the target string type.

## Symptom

Before the modification, the following error occurred.

```

DROP TABLE t1;
CREATE TABLE t1 ( c1 CHAR( 5 ) );
INSERT INTO t1 VALUES ( 'ABCDE' );
COMMIT;
gSQL> SELECT CAST( c1 AS CHAR(3) ) FROM t1;
ERR-22001(12002): byte length of data greater than column length :
SELECT CAST( c1 AS CHAR(3) ) FROM t1
      *
ERROR at line 1:

```

After the modification, the cast operation is performed by truncating the source value to match the precision of the target string type.

```

gSQL> SELECT CAST( c1 AS CHAR(3) ) FROM t1;
CAST( C1 AS CHAR(3) )
-----
ABC
1 row selected.

```

## Workaround

Specify the precision of the target string type to accommodate the source value.

## **ISSUE-6536** The DML jitter issue caused by bulk logging has been eliminated.

### Description

The issue of DML jitter caused by bulk logging during online index rebuilds has been eliminated.

### Symptom

Bulk logging can slow down the log flusher, which in turn can increase the duration for which online index rebuilds hold locks, potentially causing delays in DML operations.

**INDEX\_LOGGING\_THROTTLING** property has been newly added. It prevents bulk logging from occurring in a short period during index rebuilds.

### Workaround

The patch is required.

## **ISSUE-6543** If multiple members simultaneously raise the startup phase to global open, the server may terminate abnormally.

### Description

The issue of the server's abnormal termination when multiple members simultaneously raise the startup phase to global open has been resolved.

### Symptom

When multiple members simultaneously raise the startup phase to global open, the server may hang or terminate abnormally.

### Workaround

Only one member must raise the startup phase to global open at a time.

## **ISSUE-5544** If a transaction fails due to a disconnection with the master during replication in a cluster environment using Cyclone, the rollback logic may hang.

### Description

1. This issue occurs only in a cluster replication environment. If a previously processed transaction needs to be rolled back because the slave failed to process the transaction due to the master being terminated during replication with Cyclone, it can cause Cyclone to hang.
2. To address this, the rollback logic on the slave has been removed and replaced with a method to store all data before executing the transaction. This modification resolves the hanging issue.

### Symptom

In some cases, the slave trace log may continuously record the messages as follows, and the system may hang as a result.

```
[RECEIVER(#2)] [INFO]WAIT_WRITE_RESTART_INFO_FOR_SKIP(AnalyzeState = 1)SCN(705:10166:18)
```

### Workaround

The patch is required.

## **ISSUE-4334** It fails to join the node due to the SCN difference when ascending to Global Open.

### Description

It fails to join a cluster because the scn of a specific member is smaller than a maximum scn of the cluster, and this error has been fixed.

### Symptom

It can not ascend to Global Open with the following error.

```
gSQL> ALTER SYSTEM OPEN GLOBAL DATABASE;  
ERR-42000(16410): Startup driver node must have the latest data - a suitable startup driver  
node is 'G1N1' member
```

### Workaround

The patch is required.

## **ISSUE-6255** [CDC] PWD was exposed in the connection string recorded in the trace log, so it is replaced with '\*' when it is recorded.

### Description

PWD was exposed in the connection string recorded in the trace log of cyclone, cymon and cyfile, and this error has been fixed by replacing it with '\*' when it is recorded.

### Symptom

PWD was exposed in the connection string of cyclone, cymon and cyfile when it was recorded in the trace log.

```
connection string [PROTOCOL=DA;DSN=goldilocks_jinsil;PORT=11100;UID=test;PWD=test]
```

### Workaround

The patch is required.

## **ISSUE-6030** An error occurred in cyclone when rebalancing members in the Cluster environments, and this error has been fixed.

### Description

When rebalancing cluster members while cyclone was in operation in a cluster environment, cyclone could not process it, and this error has been fixed.

### Symptom

The followings were recorded in cyclone operated in the cluster member where rebalancing was executed, and no further operation was executed.

```
[2023-12-08 16:33:58.782398 THREAD(3292,140620625983232)]  
Ready to Rebalance-Tx commit. (Waiting for slave response)
```

### Workaround

The patch is required.

## **ISSUE-6231** An error occurs when entering GLOBAL OPEN with an invalid IP.

### Description

It failed when trying to go up to GLOBAL OPEN with an invalid remote IP, and this error has been fixed.

### Symptom

When trying to go up to GLOBAL OPEN with an invalid remote IP, it should have gone up to GLOBAL OPEN excluding the failed node, but it fails as follows.

```
gSQL> alter system open global database;  
ERR-HY000(11047): MEMBER(G1N2): invalid network address : invalid address()
```

### Workaround

Alter the IP of the failed node to the valid IP by using ALTER CLUSTER LOCATION statement.

```
gSQL> alter cluster location g1n2 host '127.0.0.1' port 12150;  
altered.
```



## 21c.1.29 Patch Notes

**ISSUE-5933** When the server performs the cluster failover, then the glocator stops.

### Description

The server property CLUSTER\_SPLIT\_BRAIN\_RESOLUTION\_POLICY is set to 1 or 2, and the glocator is waiting to receive packets during the cluster failover.

### Symptom

The glocator is waiting without receiving packets from the gagent while the glocator communicates with the gagent during the cluster failover.

### Workaround

The patch is required.

**ISSUE-5862** It supports getNetworkTimeout, setNetworkTimeout methods of JDBC connection class.

### Description

It supports getNetworkTimeout, setNetworkTimeout methods of connection class.

### Symptom

N/A

### Workaround

The patch is required.

**ISSUE-5862** If sharing JDBC connection object in multi threads and terminating the thread by the thread stop or the interrupt, then the program hangs.

## Description

If sharing the connection object in multiple threads and terminating each thread by `Thread.stop()` or `Thread.interrupt()` in the program which uses each separate statement, then the program hangs.

## Symptom

If terminating the thread by using `Thread.stop()` or `Thread.interrupt()`, then it may cause an error in the communication process. Therefore, the connection should have been closed when the thread was abnormally terminated during the communication process. The program hangs because the protocol is violated during the communication process and another thread uses the connection object while the connection object is open.

## Workaround

The patch is required.

## **ISSUE-5799** An error did not occur even though the default expression was not valid when performing CREATE TABLE/ ALTER TABLE.

## Description

If defining the default clause when performing CREATE TABLE/ ALTER TABLE, it checks whether the default expression is valid.

## Symptom

An error did not occur even though the default expression was not valid.

```
CREATE TABLE t1 ( c1 INTEGER DEFAULT 1 / 0 );
Table created.
```

It has been fixed now, so the error occurs as follows.

```
CREATE TABLE t1 ( c1 INTEGER DEFAULT 1 / 0 );
ERR-22012(12122): divisor is equal to zero
```

## Workaround

The patch is required.

## ISSUE-5828 The join query including ROWNUM should not be sent to the remote node, but sometimes it is sent.

### Description

The join query including ROWNUM should not be sent to the remote node. If each node stores data in a different order then the result may be wrong even though it is a clone table.

### Symptom

```

\explain plan
SELECT COUNT(*)
  FROM ( SELECT c1
          FROM t_clone
          WHERE ROWNUM <= 1000
        ) X
      , t_shard Y
WHERE X.c1 = Y.c1
;
COUNT(*)
-----
      1005
1 row selected.
>>> start print plan
< Execution Plan >

=====
|IDX| NODE DESCRIPTION |
-----|-----|
| 0| SELECT STATEMENT |
| 1|   QUERY BLOCK ("QB_IDX_2") |
| 2|     SINGLE CLUSTER |
| 3|       CLUSTER PUSHER ("_NI_6") |
| 4|         INLINE_VIEW ("X") |
| 5|           QUERY BLOCK ("QB_IDX_6") |
| 6|             COUNT |
| 7|               TABLE ACCESS ("T_CLONE") |
| 8|                 AGGREGATION BY HASH |
| 9|                   NESTED JOIN (INNER JOIN) |
|10|                     PUSHER TABLE ACCESS ("_NI_6") |
|11|                       INDEX ACCESS ("T_SHARD" AS Y, "T_SHARD_PRIMARY_KEY_INDEX") |
=====

```

```

1 - TARGET : COUNT(*)
2 - SQL : SELECT /*+ KEEP_JOINED_TABLE USE_HASH_IN( _A1, 7801 ) NO_MERGE( _A2 ) INDEX(
_A1, "PUBLIC"."T_SHARD_PRIMARY_KEY_INDEX" ) */ COUNT(*) FROM ( ( SELECT /*+ FULL( _A3 ) */
"_A3"."C1" FROM "PUBLIC"."T_CLONE"@LOCAL AS "_A3" WHERE ROWNUM <= :_V0 ) AS "_A2"("C1") INNER
JOIN "PUBLIC"."T_SHARD"@LOCAL AS "_A1" ON "_A1"."C1" = "_A2"."C1") ALIAS "_A4"
    TARGET DOMAIN : G1(G1N1) 1 rows, G2(G2N1) 1 rows, G3(G3N1) 1 rows
    RE-AGGREGATION
    AGGREGATION : SUM( COUNT(*) )
4 - TARGET : COUNT(*)
5 - AGGREGATION : COUNT(*)
6 - JOINED COLUMN : NOTHING
7 - COLUMN : _A3.C1 AS C1
8 - TARGET : _A3.C1
9 - STOP KEY FILTER : ROWNUM <= :_V0
10 - CLONED
    READ COLUMN : _A3.C1
11 - HASH KEY : _A1.C1
    READ KEY COLUMN : _A1.C1
    HASH FILTER : _A1.C1 = _A2.C1
    FETCH ONE ROW
12 - HASH SHARD ( # 3 )
    READ INDEX COLUMN : _A1.C1
<<< end print plan

```

The join query including ROWNUM should not be sent to the remote node, but ROWNUM filter is sent to the remote query node in the query above.

## Workaround

Use `/*+ LOCAL_JOIN(Y) */` hint.

## 21c.1.28 Patch Notes

**ISSUE-5810 [CYCLONE]** If a record does not exist in the table containing a long varchar column, then it fails to SYNC.

### Description

The error occurs because the null check for a long varchar column is incorrectly performed while checking the existence of a record in the table of the master during SYNC. It determines that there is a record even

though a record does not exist. Then, it tries to INSERT the null data to the slave, and it outputs the error message "cannot insert NULL into" and it fails to SYNC.

## Symptom

If a record does not exist in the table containing a long varchar column while transferring the data of the master to the slave by using SYNC feature during the replication using CYCLONE, then "cannot insert NULL into" error occurs, and it fails to SYNC.

## Workaround

The patch is required.

## 21c.1.27 Patch Notes

**ISSUE-5740** The property preventing DDL execution has been added.

### Description

The property preventing DDL execution has been added.

- DISABLE\_DDL
- DISABLE\_SERIAL\_DDL

### Symptom

N/A

### Workaround

The patch is required.

**ISSUE-5665** If the join including three or more tables is performed by using the instant nested loop join method, then the result may be wrong.

### Description

If the join including three or more tables is performed by using the instant nested loop join method, then the result may be wrong.

## Symptom

```
--# result : 27
\EXPLAIN PLAN
SELECT COUNT(t2.col1)
  FROM t2, t3, t4, t1
 WHERE t2.col1 + t1.col1 = t4.col1
       AND t3.col1 + t1.col1 = t4.col1;
COUNT(T2.COL1)
-----
          0
1 row selected.
>>> start print plan
< Execution Plan >
```

IDX	NODE DESCRIPTION
0	SELECT STATEMENT
1	QUERY BLOCK ("SQB_IDX_2")
2	AGGREGATION BY HASH
3	NESTED JOIN (INNER JOIN)
4	TABLE ACCESS ("T1")
5	SORT JOIN INSTANT
6	NESTED JOIN (INNER JOIN)
7	NESTED JOIN (INNER JOIN)
8	INDEX ACCESS ("T2", "T2_COL1")
9	INDEX ACCESS ("T3", "T3_COL1")
10	INDEX ACCESS ("T4", "T4_COL1")

```
-----
1 - TARGET : COUNT( T2.COL1 )
2 - AGGREGATION : COUNT( T2.COL1 )
3 - JOINED COLUMN : T2.COL1
4 - READ COLUMN : T1.COL1
5 - SORT KEY : "T4.COL1 ASC NULLS LAST"
   RECORD COLUMN : T2.COL1
   READ KEY COLUMN : T4.COL1
   READ RECORD COLUMN : T2.COL1
   MIN RANGE : T4.COL1 = T2.COL1 + {T1.COL1} AND T4.COL1 = T3.COL1 + {T1.COL1}
   MAX RANGE : T4.COL1 = T2.COL1 + {T1.COL1} AND T4.COL1 = T3.COL1 + {T1.COL1}
6 - JOINED COLUMN : T4.COL1, T2.COL1, T3.COL1
7 - JOINED COLUMN : T2.COL1, T3.COL1
```

```

8 - READ INDEX COLUMN : T2.COL1
9 - READ INDEX COLUMN : T3.COL1
10 - READ INDEX COLUMN : T4.COL1
<<< end print plan

```

The result from the query above should be '27', but actually '0' is output.

The WHERE clause condition 'T4.COL1 = T2.COL1 + T1.COL1 AND T4.COL1 = T3.COL1 + T1.COL1' can not be used as an index range condition, but actually it is used.

However, if the query is modified, then the correct result is output as follows.

```

\EXPLAIN PLAN
SELECT COUNT(t2.col1)
  FROM t2, t3, t4, t1
 WHERE t2.col1 + t1.col1 = t4.col1
       AND t3.col1 + t1.col1 = t4.col1;
COUNT(T2.COL1)
-----
                27
1 row selected.
>>> start print plan
< Execution Plan >
=====
|  IDX  |  NODE DESCRIPTION  |
-----|-----|
|   0   |  SELECT STATEMENT  |
|   1   |    QUERY BLOCK ("QB_IDX_2")  |
|   2   |      AGGREGATION BY HASH      |
|   3   |        NESTED JOIN (INNER JOIN)  |
|   4   |          NESTED JOIN (INNER JOIN)  |
|   5   |            NESTED JOIN (INNER JOIN)  |
|   6   |              INDEX ACCESS ("T2", "T2_COL1")  |
|   7   |              INDEX ACCESS ("T3", "T3_COL1")  |
|   8   |              INDEX ACCESS ("T4", "T4_COL1")  |
|   9   |        FLAT JOIN INSTANT  |
|  10   |        TABLE ACCESS ("T1")  |
=====
1 - TARGET : COUNT( T2.COL1 )
2 - AGGREGATION : COUNT( T2.COL1 )
3 - JOINED COLUMN : T3.COL1, T1.COL1, T4.COL1, T2.COL1
   ON FILTER : ( T3.COL1 + T1.COL1 ) = T4.COL1 AND ( T2.COL1 + T1.COL1 ) = T4.COL1

```

```

4 - JOINED COLUMN : T3.COL1, T4.COL1, T2.COL1
5 - JOINED COLUMN : T3.COL1, T2.COL1
6 - READ INDEX COLUMN : T2.COL1
7 - READ INDEX COLUMN : T3.COL1
8 - READ INDEX COLUMN : T4.COL1
9 - RECORD COLUMN : T1.COL1
   READ COLUMN : T1.COL1
10 - READ COLUMN : T1.COL1

```

```
<<< end print plan
```

## Workaround

Use a hint other than `USE_INL(t1)`. For example, use `USE_NL(t1)`, `USE_HASH(t1)` or `USE_MERGE(t1)`.

## **ISSUE-5447** Rolled back transaction is sometimes replicated during CYCLONE replication, and this error has been fixed.

### Description

It happens when replicating the table which has a primary key without a unique key. If the transaction performed in the database operated as CYCLONE master includes the statement which was rolled back due to the PK constraint violation, then the transaction is unintentionally replicated. In this case, the transaction replication is performed in CYCLONE slave as well, and the PK constraint violation error is recorded on CYCLONE log.

### Symptom

```

CREATE TABLE T1
(
  I1 INTEGER PRIMARY KEY,
  I2 VARCHAR(10)
)
COMMIT;
INSERT INTO T1 VALUES ( 1, 'TEST1' );
COMMIT;
INSERT INTO T1 VALUES ( 1, 'TEST1' );
ERR-23000(16057): unique constraint (PUBLIC.T1_PRIMARY_KEY) violated
COMMIT;

```



## Workaround

The patch is required.

## **ISSUE-5695** Hang occurs when expanding a disk tablespace.

### Description

Hang occurs when expanding a tablespace whose NEXT size is 128 MB or bigger.

### Symptom

```
DROP TABLESPACE TEST_TBS INCLUDING CONTENTS AND DATAFILES;
COMMIT;
CREATE DISK TABLESPACE TEST_TBS
  DATAFILE 'test.dbf' SIZE 256M AUTOEXTEND ON NEXT 128M MAXSIZE 512M;
CREATE TABLE T1
(
  I1 INTEGER,
  I2 CHAR(2000),
  I3 CHAR(2000),
  I4 CHAR(2000),
  I5 CHAR(1000)
)
TABLESPACE TEST_TBS;
COMMIT;
INSERT INTO T1 VALUES ( 1, 1, 1, 1, 1 );
INSERT INTO T1 SELECT * FROM T1 LIMIT 8192;
INSERT INTO T1 SELECT * FROM T1 LIMIT 8192;
...(Ellipsis)...
INSERT INTO T1 SELECT * FROM T1 LIMIT 8192; -- hang
```

## Workaround

Set the NEXT size of the tablespace to 128 MB or smaller.

**ISSUE-5667** When a subquery refers to the outer query, if the subquery refers to both a materialized view and an ordinary table, then the server is abnormally terminated.

## Description

If all of the following conditions are satisfied, then the server is abnormally terminated.

1. When tables are listed in <from clause>, the materialized view specified by <with clause> is listed ahead, followed by the ordinary table.
2. A subquery exists and the subquery refers to both a materialized view and an ordinary table.

## Symptom

```

DROP TABLE IF EXISTS r;
DROP TABLE IF EXISTS s;
DROP TABLE IF EXISTS t;
CREATE TABLE r ( c1 INTEGER, c2 INTEGER );
INSERT INTO r VALUES(1,1);
CREATE TABLE s ( c1 INTEGER, c2 INTEGER, c3 INTEGER );
INSERT INTO s VALUES(1,1,1);
CREATE TABLE t ( c1 INTEGER, c2 INTEGER );
INSERT INTO t VALUES(1,1);
COMMIT;
--# result : 1 row
\EXPLAIN PLAN
WITH w AS ( SELECT /*+ MATERIALIZE */
             c1
             FROM r
             WHERE c1 > 0 )
SELECT *
  FROM w, s
 WHERE s.c1 IN ( SELECT t.c1
                 FROM t
                 WHERE s.c1 = t.c1
                   AND w.c1 = t.c2
                 ) ;

```

In the query above, w and s are listed in an order of w,s in FROM clause, and the subquery refers to both s.c1 and w.c1. In this case, the server is abnormally terminated.

## Workaround

List the materialized view last in FROM clause.

## 21c.1.26 Patch Notes

**ISSUE-5442 [CYCLONE] If replicating the column with a unique attribute, then the transaction may fail.**

### Description

If a column has a unique attribute in the table to replicate, then it is normally processed in an source database, but unique violation or NO\_ROWS error may occur in a remote database. Therefore, to solve this problem, the feature to control concurrency of the column has been added when replicating the column with the unique attribute.

### Symptom

```
[APPLIER #1(SID:100)-INSERT] ERR-23000(16057) : unique constraint (PUBLIC.TEST1) violated
[APPLIER #2(SID:101)-UPDATE] Conflict.
[APPLIER #3(SID:102)-DELETE] Conflict.
```

If a column has a unique attribute in the replicating table, then logs are frequently recorded on the trace log of the slave as given above.

## Workaround

The patch is required.

**ISSUE-5568 [CYCLONE] If replicating recovery spans two redo log files, then the starting point of the recovery is incorrectly set.**

### Description

When restarting after terminating the replication, cyclone finds the starting point of the recovery by using the information applied to the existing applier, then restarts the replication.

When recovering, it finds the optimal starting point by comparing the information between multiple appliers. If the redo log file information between appliers is different, then it discards the information of the old redo log file, and determines the starting point of the recovery by using only the new redo log file information, and this error has been fixed.

## Symptom

When restarting after terminating the replication, a transaction may not be replicated.

## Workaround

The patch is required.

## 21c.1.25 Patch Notes

### **ISSUE-5511** [CYCLONE] The internal transaction ID is set incorrectly in the distributor.

#### Description

It is guaranteed that the transaction IDs are not duplicated among simultaneously performed transactions in an original database. However, the completed transaction ID can be reused later.

When transferring the transaction to the slave after extracting the original transaction for the replication, the execution time of the transaction ID may be different from the original due to the parallel apply. In this case, the slave changes the separate transaction ID into the internally distinguishable ID to prevent identity duplication by reusing the transaction ID.

This internal transaction ID is allocated by the distributor, but it uses the original value instead of the internal value while analyzing specific logs, so the problem occurs, which a single transaction has two transaction IDs.

Two transaction ID values used as a delimiter value of concurrency control in distributor are allocated to a single transaction, so self dead-lock may occur in a specific situation.

#### Symptom

```
CREATE TABLE T1 ( C1 INTEGER PRIMARY KEY, C2 LONG VARCHAR );
INSERT INTO T1 VALUES( 1, 'AAA' );
DELETE FROM T1 WHERE C1=1;
INSERT INTO T1 VALUES( 1, 'AAAAAAA .....' ); ① INSERT the data over 8K
COMMIT;
```

As above, if performing the query processing the same key value and INSERT which inserts the record over 8K in a single transaction, then the dead-lock occurs.

## Workaround

The patch is required.

**ISSUE-5505** If the access method for leftmost table in the join is the unique index access, and only part of key columns in the group by belong to the unique index, then the result may be wrong.

## Description

If the access method for leftmost table in the join is the unique index access, and only part of key columns in the group by belong to the unique index, then the result may be wrong.

## Symptom

```

DROP TABLE IF EXISTS r;
DROP TABLE IF EXISTS s;
DROP TABLE IF EXISTS t;
CREATE TABLE r( c1 INTEGER, c2 INTEGER, c3 INTEGER, c4 INTEGER, c5 INTEGER );
INSERT INTO r VALUES(1, 1, 1, 1, 1);
INSERT INTO r VALUES(1, 2, 1, 1, 1);
INSERT INTO r VALUES(1, 2, 1, 1, 1);
INSERT INTO r VALUES(2, 1, 2, 1, 1);
INSERT INTO r VALUES(2, 1, 2, 2, 1);
INSERT INTO r VALUES(3, 1, 2, 2, 1);
INSERT INTO r VALUES(3, 2, 3, 2, 1);
INSERT INTO r VALUES(4, 1, 3, 3, 1);
INSERT INTO r VALUES(5, 1, 3, 3, 1);
INSERT INTO r VALUES(1, 3, 2, 1, 1);
INSERT INTO r VALUES(1, 1, 1, 1, 1);
COMMIT;
CREATE TABLE s( c1 INTEGER PRIMARY KEY, c2 INTEGER, c3 INTEGER, c4 INTEGER, c5 INTEGER );
INSERT INTO s VALUES(1, 1, 1, 1, 1);
INSERT INTO s VALUES(2, 3, 1, 1, 1);
INSERT INTO s VALUES(3, 3, 1, 1, 1);
INSERT INTO s VALUES(4, 2, 2, 1, 1);
INSERT INTO s VALUES(5, 2, 2, 2, 1);
INSERT INTO s VALUES(6, 1, 2, 2, 1);
INSERT INTO s VALUES(7, 1, 3, 2, 1);
INSERT INTO s VALUES(8, 3, 3, 3, 1);
INSERT INTO s VALUES(9, 3, 3, 3, 1);

```

```

COMMIT;
CREATE TABLE t( c1 INTEGER, c2 INTEGER, c3 INTEGER, c4 INTEGER, c5 INTEGER );
INSERT INTO t VALUES(1, 1, 1, 1, 1);
INSERT INTO t VALUES(1, 3, 3, 1, 1);
INSERT INTO t VALUES(1, 3, 3, 1, 1);
INSERT INTO t VALUES(1, 2, 2, 1, 1);
INSERT INTO t VALUES(1, 2, 2, 1, 1);
INSERT INTO t VALUES(2, 3, 1, 1, 1);
INSERT INTO t VALUES(3, 3, 1, 1, 1);
INSERT INTO t VALUES(4, 2, 2, 1, 1);
INSERT INTO t VALUES(5, 2, 2, 2, 1);
COMMIT;
--# result : 6 rows
\EXPLAIN PLAN
SELECT s.c1, s.c2, t.c3
   FROM s, r, t
  WHERE s.c1 > 0 AND s.c1 < 5
        AND s.c1 = r.c1
        AND r.c1 = t.c1
  GROUP BY s.c1, s.c2, t.c3;
C1 C2 C3
-- -- --
 1  1  2
 1  1  3
 1  1  1
 1  1  2
 1  1  3
 1  1  1
 1  1  2
...
18 rows selected
< Execution Plan >
=====
|  IDX  |  NODE DESCRIPTION  |
-----|-----|
|    0  |  SELECT STATEMENT  |
|    1  |    QUERY BLOCK ("SQB_IDX_2")  |
|    2  |      GROUP  |
|    3  |        HASH JOIN (INNER JOIN)  |
|    4  |          MERGE JOIN (INNER JOIN)  |
|    5  |            INDEX ACCESS ("S", "S_PRIMARY_KEY_INDEX")  |

```

```

| 6 |          INDEX ACCESS ("R", "R_IDX")          |
| 7 |          HASH JOIN INSTANT                     |
| 8 |          TABLE ACCESS ("T")                  |
=====

```

The result from the query above should be 6 rows, but actually 18 rows are output. The leftmost table uses 'S\_PRIMARY\_KEY\_INDEX', so the join result is sorted for s.c1. In the plan above, group by performs the grouping by using the sorted result of the join. However, the sorted records are not sorted for all group key columns, so it may lead to the wrong result.

## Workaround

Use `/*+ USE_GROUP_HASH */` hint.

## **ISSUE-5445** Even if LOGFILE GROUP size is set sufficiently it fails to add LOGFILE GROUP when performing ADD LOGFILE GROUP.

### Description

Even if LOGFILE GROUP size is set sufficiently it fails to add LOGFILE GROUP with a error message saying the logfile is smaller than the minimum size.

It is because the minimum size of the logfile should be calculated based on the number of log buffers and pending log buffers which were revised during the startup, but actually it is calculated based on the property value when performing ADD LOGFILE GROUP.

### Symptom

If attempting to add a logfile group after starting up to mount phase with PROPERTY set as follows, then it fails.

```

LOG_BUFFER_SIZE=1G
PENDING_LOG_BUFFER_COUNT=32

```

```

gSQL> STARTUP MOUNT
Startup success
gSQL> ALTER DATABASE ADD LOGFILE GROUP 4 ('redo_4_0.log') SIZE 512M;
ERR-42000(16198): size of log file is smaller than minimum size of log file(1107296256 bytes).

```

## Workaround

Create a logfile group by revising LOG\_BUFFER\_SIZE property and PENDING\_LOG\_BUFFER\_COUNT property.

**ISSUE-5424** If executing SELECT statement of an embedded SQL without INTO clause, then an error occurs even when the data exists, and this error has been fixed.

### Description

If repeatedly executing SELECT statement of an embedded SQL without INTO clause, then an error occurs, and this error has been fixed.

### Symptom

```
EXEC SQL SELECT 1 FROM DUAL;
EXEC SQL SELECT 1 FROM DUAL;
```

If repeatedly executing the same SELECT statement as given above, then the following error occurs.

```
Invalid cursor state : A cursor was open on the StatementHandle.
```

### Workaround

Add INTO clause to the SELECT statement, then execute it.

**ISSUE-5407** Cluster peer which is waiting for the lock to be released can not recognize that driver node is killed.

### Description

If the driver member is abnormally terminated while waiting for the lock to be released on the remote, then the remotely created session remains alive.

### Symptom

The following is an example of an environment that the cluster group G1 has G1N1, G1N2 as members, and the table T1 is created.

The record of table T1 is updated on G1N1.

```
gSQL> UPDATE T1 SET A = A + 1 WHERE A = 1;
1 row updated.
```

If the same record is updated on G1N2, then it will wait.



```
gSQL> UPDATE T1 SET A = 10 WHERE A = 1;
```

When checking the session on G1N1, then it is seen that the cluster session is waiting for the update sent from G1N2.

```
gSQL> SELECT SESSION_STATUS FROM V$SESSION@G1N1
        WHERE PROGRAM_NAME = 'cluster peer';
SESSION_STATUS
-----
CONNECTED
```

Even when gsql waiting for the update sent from G1N2 is killed, the session still remains alive on G1N1 as follows.

```
gSQL> SELECT SESSION_STATUS FROM V$SESSION@G1N1
        WHERE PROGRAM_NAME = 'cluster peer';
SESSION_STATUS
-----
CONNECTED
```

## Workaround

The patch is required.

## 21c.1.24 Patch Notes

**ISSUE-5398** The data is lost when gloder uploads the data in the text mode, and this error has been fixed.

### Description

gloder uses the field delimiter and the line delimiter which start with the same character when uploading the data in the text mode. If the data includes the first character of these delimiter, then the data is truncated and uploaded in an invalid form, and this error has been fixed.

### Symptom

The following is an example of a data file.

```
data 1^^^Cc__Cc^data 2^Rr__Rr
```

The following is an example of a control file.

```
TABLE TEST
FIELD TERMINATED BY '^Cc__Cc^'
LINE TERMINATED BY '^Rr__Rr\n'
```

If uploading the data by using the control file and the data file above, then the data is truncated.

```
gloader test test -i --control test.ctl --data test.dat --array 1 --no-copyright
COMPLETED IN IMPORTING TABLE: PUBLIC.TEST, TOTAL 3 RECORDS, SUCCEEDED 3 RECORDS
gSQL> SELECT * FROM TEST;
C1      C2
-----
data 1^ null
^       null
null    data 2^Rr__Rr
```

## Workaround

Use the the field delimiter and the line delimiter which start with the different character each other.

## **ISSUE-5174** gpec supports declaring function arguments.

### Description

gpec supports declaring function arguments. For more information, refer to [Declaring Function Arguments](#).

### Symptom

N/A

### Workaround

The patch is required.

**ISSUE-5353** When connecting and disconnecting by using the window ODBC, then the number of program handles increase and this error has been fixed.

### Description

When repeatedly connecting and disconnecting by using the window ODBC, then the number of entire program handles increase and this error has been fixed.

### Symptom

When repeatedly connecting and disconnecting by using the window ODBC, then the number of entire program handles increase.

### Workaround

The patch is required.

**ISSUE-5344** When performing view projection pruning it deletes the column used in the upper block.

### Description

If the following conditions are satisfied, the server may be abnormally terminated due to improperly performed view projection pruning.

- *group by* or *order by* exists within a view.
- expr to be deleted from the view's select list is an argument of another function expression.

### Symptom

The following is a sample query which can cause an error.

```
SELECT sum_col1
FROM ( SELECT sum(col1) as sum_col1
      , DECODE( sum(col1), NULL, 0 ) as decode_sum_col1
      FROM t1
      GROUP BY col2
    ) v1;
```

decode\_sum\_col1 is not used in the upper block in v1, so it is pruned. Moreover, sum(col1) which is an argument of DECODE is also pruned. However, sum(col1) is already specified in select list and it is used in t

the view's upper block, so it should not be deleted.

## Workaround

The patch is required.

## **ISSUE-5336** When using SUBQUERY in SELECT INTO statement of gpec, then it is not processed as a SELECT INTO statement.

### Description

If gpec parses the SQL which has SUBQUERY after a SELECT INTO statement, then it is not processed as a SELECT INTO statement.

### Symptom

The following is an example of using SUBQUERY after using the host variable array in a SELECT INTO statement.

```
EXEC SQL BEGIN DECLARE SECTION;
int no[10];
int count[10];
EXEC SQL END DECLARE SECTION;
EXEC SQL SELECT empno, B.COUNT
      INTO :no, :count,
      FROM emp, (SELECT count(*) as COUNT FROM emp);
```

When performing the example above, then the following error occurs.

```
SQLCODE :-16289
SQLSTATE: 42000
ERROR MSG : into clause can have only one row
```

## Workaround

Fetch the cursor instead of using the host variable array in a SELECT INTO statement.

## **ISSUE-4945** Use SQLTables to check the existence of the table while creating a table to operate CYCLONE, CYMON.

### Description

It has been modified to create the table after checking the existence of the table required to operate CYCLONE, CYMON by using SQLTables.

### Symptom

N/A

### Workaround

Validate the table existence when preparing, then use the result to determine whether the table exist.

## **ISSUE-5245** CLUSTER\_PACKET\_ALLOCATION\_TIMEOUT should be processed in the unit of second.

### Description

The unit of CLUSTER\_PACKET\_ALLOCATION\_TIMEOUT is second, but it is internally processed in the unit of micro second.

### Symptom

If multiple load protocols occur due to the cluster pusher plan, then the following error frequently occurs.

```
SELECT /*+
      REMOTE_JOIN(s)
      PUSHER(s)
    */
COUNT(*)
FROM r, s
WHERE r.c1 = s.sk
;
ERR-40000(56008): transaction rollback: failed to synchronize replicas
ERR-HYT00(13059): Exceeded maximum packet allocation time
```

### Workaround

The patch is required.

**ISSUE-5029** Even when the master rejoins with reset all option while operating Cyclone in the cluster environment, but the existing replication information is not initialized.

### Description

When restarting the previously operated master with reset all option while Cyclone is operating in the cluster environment, then it should not use the existing replication information, and the replication should be resumed from the current time.

### Symptom

Even when restarting the master with reset all option, the recovery process uses the existing replication operating information.

### Workaround

The patch is required.

## 21c.1.23 Patch Notes

**ISSUE-5132** It supports DML execution for the single domain table without the global secondary index in the cluster environment.

### Description

If the global secondary index is not configured when executing DML for the single domain table in cluster environment, then it may fail. DML query requires the global secondary index to guarantee the data consistency between servers. Therefore, if the data is stored in a single server, and it is not required to guarantee the data consistency between server, then it supports DML without the global secondary index.

It is recommended to configure the global secondary index to manage a single table in multiple servers in cluster environment.

### Symptom

```
--# G4 group has G4N1 only.
CREATE TABLE r ( c1 INTEGER )
  CLONED
  AT CLUSTER GROUP g4
  WITHOUT GLOBAL SECONDARY INDEX;
```

```

--# result: success
INSERT INTO r VALUES (1), (2), (3);
--# Improvement
--# result: success
DELETE FROM r WHERE c1 = 2;
ERR-42000(16519): global secondary index expected in cluster DML

```

## Workaround

The patch is required.

## **ISSUE-5193** When executing a query including index backward scan in cluster environment, then the result is wrong.

### Description

When executing the user query in cluster environment, if it is required to access the remote server and the user query includes index backward scan by ORDER BY statement or by a hint, then the query result may be in an order of index forward scan.

### Symptom

If it is required to access the remote server when executing the user query in cluster environment, then the generated query is configured and transferred to the remote server. However, the remote server performs the index forward scan because the access path hint information is wrong when configuring the generated query including the index backward scan.

```

CREATE TABLE t1
(
  c1 INTEGER
)
  SHARDING BY RANGE ( c1 )
  SHARD s1 VALUES LESS THAN ( 10 )      AT CLUSTER GROUP g1,
  SHARD s2 VALUES LESS THAN ( MAXVALUE ) AT CLUSTER GROUP g2;
INSERT INTO t1 VALUES ( 12 );
INSERT INTO t1 VALUES ( 11 );
INSERT INTO t1 VALUES ( NULL );
CREATE INDEX t1_idx1 ON t1( c1 ASC NULLS LAST );
--# BUGBUG
--# result: 3 rows
--#      null
--#      12

```

```

--#          11
\EXPLAIN PLAN
SELECT c1 FROM t1@g2 ORDER BY c1 DESC NULLS FIRST;
  C1
----
  11
  12
 null
3 rows selected.

```

## Workaround

The patch is required.

## **ISSUE-5109** Cyclone malfunctions after shard rebalancing and split brain, and this error has been fixed.

### Description

When recovering after shard rebalancing and split brain, Cyclone is terminated with "internal error occurred (Not Need Rebalance)" error.

### Symptom

Even when cyclone determines rebalancing is not required, but it is rebalanced in a specific situation. This may happen in shard rebalancing and split brain situation.

### Workaround

Restart Cyclone with --reset.

## **ISSUE-5162** Even when SQL\_ATTR\_CONNECTION\_TIMEOUT is set in ODBC, it may wait longer than the settings, and this error has been fixed.

### Description

Even when SQL\_ATTR\_CONNECTION\_TIMEOUT is set in ODBC to detect the network disconnection, it may wait longer than the given timeout setting, and this error has been fixed.



## Symptom

Even when SQL\_ATTR\_CONNECTION\_TIMEOUT is set in ODBC, it can not detect the network disconnection in a specific situation, so it keeps waiting for the server's response in ODBC.

## Workaround

Add the following attributes to odbc.ini, so that it can quickly detect the network disconnection.

- KEEPALIVE\_IDLE\_TIME
- KEEPALIVE\_INTERVAL
- KEEPALIVE\_COUNT

Or, alter the following kernel attributes, so that it can quickly detect the network disconnection.

- net.ipv4.tcp\_keepalive\_intvl
- net.ipv4.tcp\_keepalive\_probes
- net.ipv4.tcp\_keepalive\_time
- net.ipv4.tcp\_retries2

**ISSUE-5160** When LONGVARCHAR, LONGVARBINARY parameters exist in ODBC global connection environment, the client's memory increases, and this error has been fixed.

## Description

When repeatedly performing the statement including LONGVARCHAR, LONGVARBINARY parameters in ODBC global connection environment, the client's memory increases, and this error has been fixed.

## Symptom

When repeatedly performing the SQL including LONGVARCHAR, LONGVARBINARY parameters with the same statement in ODBC global connection environment, the client's memory increased.

## Workaround

The patch is required.

**ISSUE-5156** SQLSTATEs of some errors have been changed.

## Description

SQLSTATEs of some errors have been changed.

## Symptom

SQLSTATEs of some errors have been changed as follows.

Error number	Old SQLSTATE	Modified SQLSTATE	Message
13034	RD000	08S01	Service is not available
16351	08000	HY000	failed to connect to the cluster member '%s'
16523	HY000	08S01	the database system is shutting down
25001	HY000	08001	Server is not running

## Workaround

The patch is required.

**ISSUE-5147** Even when it was set as `PROTOCOL=TCP` in the configuration of CYMON, it was connected by using DA, and this error has been fixed.

## Description

Even when it was set as `PROTOCOL=TCP` in the configuration of CYMON, it was connected by using DA. However, this error has been fixed, so it is connected by using TCP now.

## Symptom

If it is set as `PROTOCOL=TCP` in the configuration of CYMON, it should be connected by using TCP, but, in reality, it is connected by using DA.

## Workaround

The patch is required.

**ISSUE-5124** If it fails to allocating dynamic memory, then it may kill the server due to the simultaneity issue.

## Description

If it fails to allocating dynamic memory, then it may kill the server due to the simultaneity issue.

## Symptom

If it fails while multiple threads allocate a single dynamic memory, then it may kill the server due to the simultaneity issue.

## Workaround

The patch is required.

## **ISSUE-4985** The progressing information in slave has been added to the CYCLONE's monitoring information.

### Description

The information being processed in slave (Apply\_FileSeq, Apply\_BlockSeq, Apply\_Commit\_Lsn) has been added to the CYCLONE's monitoring information.

### Symptom

N/A

### Workaround

The patch is required.

## **ISSUE-4882** It is modified to report the detatiled error message when a n error occurs while processing CYCLONE SYNC.

### 개요

It is modified to record the detailed error message together with *ERROR OCCURRED* on the trace log when an error occurs while processing CYCLONE SYNC.

### Symptom

N/A

## Workaround

The patch is required.

## 21c.1.22 Patch Notes

**ISSUE-5030** When performing ALTER SYSTEM JOIN DATABASE, the SN IPED session is not cleared.

### Description

When performing ALTER SYSTEM JOIN DATABASE, topology information among cluster members temporarily do not match. And if COMMIT occurs at this moment, then it infinitely waits for invalid COMMIT result due to the wrong topology information.

### Symptom

When performing ALTER SYSTEM JOIN DATABASE after restarting a member in cluster environment, if COMMIT occurs for the member, then intermittently it is not normally processed but it infinitely waits for the result.

### Workaround

Restart the server.

**ISSUE-5004** A deadlock occurs on the slave's pre-process phase during the replication with cyclone in the cluster environment.

### Description

A deadlock intermittently occurs during the replication with cyclone in the cluster environment.

### Symptom

The replication is not proceeding and it seems to be stop. It is because a deadlock occurs during the pre-process for the replication in the cluster environment. The replication is not proceeding any more even when monitoring with cymon.

### Workaround

Reset the master and the slave of cyclone.

## 21c.1.21 Patch Notes

**ISSUE-4933** If the server becomes unavailable while using JDBC XA, then it should transfer XA error to the client.

### Description

If the server becomes unavailable while using JDBC XA, then it should transfer XA error to the client.

### Symptom

If the server becomes unavailable while using JDBC XA, then it should transfer XA error to the client. However, in reality, it does not transfer XA error and it is operated as if it succeeds.

### Workaround

The patch is required.

**ISSUE-4882** When performing cyclone sync, string data right truncated error occurs for the long variable datatype.

### Description

While performing cyclone sync, string data right truncated error occurs.

### Symptom

An error may occur when syncing the table including a long varchar/ varbinary type column. This error occurs because the null padding of the buffer used for the sync is lost, and it occurs when the column data size is 8 Kb.

### Workaround

The patch is required.

**ISSUE-4873** It supports XA rollback feature for XA transaction which is not dissociated from the session.

## Description

XA transaction is associated with the session until performing `xa end`, and to commit or rollback the XA transaction, it should be dissociated from the session. However, other DBMS support the rollback feature even when the transaction is not dissociated from the session. Therefore, it has been improved to support the same feature.

## Symptom

If performing `xa rollback` without performing `xa end` for the XA transaction in progress in the session, then an error occurs. However, it is normally operated if performing `xa rollback` after performing `xa end`.

```
gSQL> XA START 10
XA transaction started
gSQL> INSERT INTO T1 VALUES ( 1 );
1 row created.
gSQL> XA ROLLBACK 10
ERR-HY000(40035): resource manager unavailable
gSQL> XA END 10 SUCCESS
XA transaction ended
gSQL> XA ROLLBACK 10
Rollback completed
```

## Workaround

The patch is required.

## **ISSUE-4864** The shard is not refined when restarting after dropping the shard.

### Description

If the shard is moved in `ALTER TABLE REBALANCE` statement, then the shard may be dropped. If restarting the server before the server refines the dropped shards, then the dropped shard may not be refined.

### Symptom

If performing `SHUTDOWN` right after `REBALANCE` as follows, then the moved shard may not be dropped.

```
gSQL> ALTER TABLE T1 REBALANCE;
Table altered.
gSQL> \SHUTDOWN ABORT
Shutdown success
```

## Workaround

The patch is required.

### **ISSUE-4863** Lock is not converted to optimistic mode after REBALANCE.

#### Description

The lock which was converted to the pessimistic mode during ALTER TABLE REBALANCE is not converted to optimistic mode, so the performance may be degraded.

#### Symptom

If performing ALTER TABLE REBALANCE ONLINE when DML occurs, then the performance may be degraded.

## Workaround

The patch is required.

### **ISSUE-4850** When using async commit, the sequence of the journal record may be reversed.

#### Description

If DML occurs while performing ONLINE REBALANCE in the environment where asynchronous commit is set then the sequence of the journal record may be reversed. If so, the process performing REBALANCE may be abnormally terminated during the journal replay.

#### Symptom

If performing REBALANCE in the environment where asynchronous commit is set, and insert and delete occur in the same record of each different transaction as follows, then the process performing REBALANCE may be abnormally terminated.

```
gSQL> ALTER SYSTEM SET CLUSTER_ASYNC_COMMIT = TRUE;
```

```
System altered.
```

```
gSQL> ALTER TABLE T1 REBALANCE;
```

```
gSQL> INSERT INTO T1 VALUES (1);
```

```
1 row created.
```

```
gSQL> COMMIT;
```

```
Commit complete.
```

```
gSQL> DELETE FROM T1 WHERE I1 = 1;
1 row deleted.
gSQL> COMMIT;
Commit complete.
```

## Workaround

Set *asynchronous commit* to FALSE.

## 21c.1.20 Patch Notes

**ISSUE-4753** When enquiring USER\_TABLES, the global temporary table is not viewed.

### Description

When enquiring the dictionary view such as USER\_TABLES, ALL\_TABLES and DBA\_TABLES, the global temporary table is not viewed.

### Symptom

Even though enquiring the global temporary table through USER\_TABLES after the global temporary table has been created as follows, but the global temporary table is not viewed.

```
gSQL> CREATE GLOBAL TEMPORARY TABLE gt1 ( c1 INTEGER ) ON COMMIT DELETE ROWS;
Table created.
gSQL> CREATE GLOBAL TEMPORARY TABLE gt2 ( c1 INTEGER ) ON COMMIT PRESERVE ROWS;
Table created.
gSQL> COMMIT;
Commit complete.
gSQL>
SELECT table_schema
       , table_name
       , temporary
       , duration
FROM USER_TABLES
WHERE table_name IN ( 'GT1', 'GT2' )
ORDER BY 2
;
no rows selected.
```



The correct result is viewed as follows after patching.

```
gSQL>
SELECT table_schema
       , table_name
       , table_type
       , commit_action
FROM TABLES
WHERE table_name IN ( 'GT1', 'GT2' )
ORDER BY 2
;
TABLE_SCHEMA TABLE_NAME TABLE_TYPE      COMMIT_ACTION
-----
PUBLIC      GT1          GLOBAL TEMPORARY DELETE
PUBLIC      GT2          GLOBAL TEMPORARY PRESERVE
2 rows selected.
```

Execute DictionarySchema.sql to apply the patch as follows.

- Standalone

```
% gsql sys gliese --as sysdba --import $GOLDILOCKS_HOME/admin/standalone/DictionarySchema.sql
```

- Cluster

```
% gsql sys gliese --as sysdba --import $GOLDILOCKS_HOME/admin/cluster/DictionarySchema.sql
```

## Workaround

Enquire the SQL standard INFORMATION\_SCHEMA.TABLES.

```
gSQL>
SELECT table_schema
       , table_name
       , table_type
       , commit_action
FROM TABLES
WHERE table_name IN ( 'GT1', 'GT2' )
ORDER BY 2
;
TABLE_SCHEMA TABLE_NAME TABLE_TYPE      COMMIT_ACTION
-----
PUBLIC      GT1          GLOBAL TEMPORARY DELETE
```

PUBLIC GT2 GLOBAL TEMPORARY PRESERVE

2 rows selected.

## **ISSUE-4720** When the file system storage space is full, then the system thread is abnormally terminated.

### **Description**

Previously, gmaster archive thread was abnormally terminated, when the file system storage space for the archive log was full. However, it is modified not to terminate the thread but to perform the failed archive again when the file system space becomes sufficient.

### **Symptom**

If the file system was full during creating the archive log, then the archive failed, and gmaster archive thread was abnormally terminated.

### **Workaround**

The patch is required.

## **21c.1.19 Patch Notes**

### **ISSUE-4713** Conflict error occurs in slave when replicating cyclone.

#### **Description**

If CLUSTER\_ASYNC\_COMMIT property for slave is set to YES, then update conflict error occurs.

#### **Symptom**

When CLUSTER\_ASYNC\_COMMIT property is set to YES, if the value applied by an applier is not completely committed and another applier accesses to the record which was just applied, then conflict error may occur.

Therefore, it is modified to set CLUSTER\_ASYNC\_COMMIT to NO when starting cyclone slave.

#### **Workaround**

Set CLUSTER\_ASYNC\_COMMIT of GOLDLOCKS where slave is operated to NO.

```
gSQL> ALTER SYSTEM SET CLUSTER_ASYNC_COMMIT=NO;
System altered.
```

## **ISSUE-4709** Query execution for the local node may fail on local open phase.

### Description

If enquiring the table by connecting to the node on local open phase in cluster environment, then an error occurs.

### Symptom

If the connected node is on local open phase, then it can not access the remote node but it can access the local node. However, if it determines that the node on local open phase can not access the local node, then the query fails.

The following is an example of an error occurred when executing the query on G1N1 on local open phase.

```
gSQL> SELECT * FROM v$datafile;
ERR-HY000(16354): connection of member 'G1N1' is broken
```

It determines whether the current node can access a specific node based on the connection information. However, if it can not refer to the connection information in case when it is on local open phase, then it may determine that it can not access the current node either.

It is modified to determine that it can access the current node even when it can not refer to the connection information.

### Workaround

The patch is required.

## **ISSUE-4693** If the inner query of the view is left outer join which has both *on filter* and *where filter*, and this view is merged, then the result may be wrong.

### Description

If the inner query of the view is left outer join which has both *on filter* and *where filter*, and this view is merged, then the result may be wrong.

## Symptom

The result of the query below is 1, but the actual output result is 2.

```

CREATE TABLE r ( r_c1 INTEGER NOT NULL, r_c2 INTEGER );
CREATE TABLE s ( s_c1 INTEGER NOT NULL, s_c2 INTEGER );
CREATE TABLE t ( t_c1 INTEGER NOT NULL, t_c2 INTEGER );
CREATE UNIQUE INDEX idx_r_c1 ON r( r_c1 );
CREATE UNIQUE INDEX idx_s_c1 ON s( s_c1 );
CREATE UNIQUE INDEX idx_t_c1 ON t( t_c1 );
INSERT INTO r VALUES ( 1, 1 );
INSERT INTO r VALUES ( 2, 2 );
INSERT INTO s VALUES ( 1, 1 );
INSERT INTO s VALUES ( 2, 2 );
INSERT INTO t VALUES ( 1, 1 );
INSERT INTO t VALUES ( 2, 2 );
COMMIT;
SELECT
    COUNT(*)
FROM ( SELECT r_c1
        , s_c1
        FROM r
        LEFT JOIN
        s
        ON r_c1 = s_c1
        WHERE
        r_c2 = 1
        ) v1
, t
WHERE v1.r_c1 = t_c2
;
COUNT(*)
-----
2
1 row selected.
```

In the query above, `s_c1` column of `v1`'s inner query is not used out of view. Therefore, it is dropped on query transform phase, then it is simple view merged.

```

SELECT
    COUNT(*)
FROM r LEFT JOIN s ON r_c1 = s_c1
```

```

    , t
WHERE v1.r_c1 = t_c2
      AND r_c2 = 1
;

```

After that, left outer join whole may be dropped as follows because `s_c1` is a unique key column and it is not used except for left outer join.

```

SELECT
    COUNT(*)
FROM r
    , t
WHERE v1.r_c1 = t_c2
      AND r_c2 = 1
;

```

`r_c2 = 1` was lost on query transform phase as given above, and it was an error. However, the error is fixed now, so the result is correct as follows.

```

\EXPLAIN PLAN
SELECT
    COUNT(*)
FROM ( SELECT r_c1
        , s_c1
      FROM r
        LEFT JOIN
          s
        ON r_c1 = s_c1
      WHERE
        r_c2 = 1
    ) v1
    , t
WHERE v1.r_c1 = t_c2
;

```

```

COUNT(*)
-----

```

```

1

```

```

1 row selected.

```

```

>>> start print plan

```

```

< Execution Plan >

```

```

=====
|  IDX  |  NODE DESCRIPTION  |

```

```

-----
|  0 | SELECT STATEMENT |
|  1 |   QUERY BLOCK ("QB_IDX_2") |
|  2 |     AGGREGATION BY HASH |
|  3 |       HASH JOIN (INNER JOIN) |
|  4 |         TABLE ACCESS ("T") |
|  5 |           HASH JOIN INSTANT |
|  6 |             TABLE ACCESS ("R") |
=====
1 - TARGET : COUNT(*)
2 - AGGREGATION : COUNT(*)
3 - JOINED COLUMN : NOTHING
4 - READ COLUMN : T.T_C2
5 - HASH KEY : R.R_C1
   READ KEY COLUMN : R.R_C1
   HASH FILTER : R.R_C1 = T.T_C2
   FETCH ONE ROW
6 - READ COLUMN : R.R_C1, R.R_C2
   PHYSICAL FILTER : R.R_C2 = 1
<<< end print plan

```

## Workaround

Use `/*+ NO_MERGE(v1) */` hint.

## **ISSUE-4696** View columns have been added to view the update master information of the cluster table.

### Description

The update master in the cluster table is a member node where DML is first performed when DML occurs in the table.

The followings affect determining the update master of each cluster table.

- Positioning cluster table
- Position of members in the cluster group
- Whether it is online/ offline
- Whether to perform rebalance

IS\_UPDATE\_MASTER column has been added to the following dictionary views to easily view the update master information which is subject to change during the operation.

- DBA\_TAB\_PLACE
- ALL\_TAB\_PLACE
- USER\_TAB\_PLACE

## Symptom

View it as follows.

```
SELECT group_name, member_name, is_update_master
   FROM user_tab_place
  WHERE table_name = 'R';
GROUP_NAME MEMBER_NAME IS_UPDATE_MASTER
-----
G1          G1N1          TRUE
G1          G1N2          FALSE
G2          G2N1          TRUE
G2          G2N2          FALSE
G3          G3N1          TRUE
G3          G3N2          FALSE
6 rows selected.
```

Cluster table R is located in groups G1, G2, G3, and the member corresponding to update master in each group is G1N1, G2N1 and G3N1.

## Workaround

The patch is required.

## 21c.1.18 Patch Notes

**ISSUE-4646** If the inner query of the view is a set and it has *order by* clause, then the result is wrong.

### Description

If the inner query of the view is a set and it has *order by* clause, then the result is wrong. In this case, only *union all* is allowed in the set and only some view columns should be used.

## Symptom

v1 view in the following example has c1, c2, c3 and c4, but it only reads c1, c3 columns. Moreover, the inner query of the view is a set clause which used *union all* only, and it has *order by*.

In this case, the result is wrong.

```
CREATE TABLE t1 ( c1 INTEGER, c2 INTEGER, c3 INTEGER, c4 INTEGER );
INSERT INTO t1 VALUES(1,1,1,1);
INSERT INTO t1 VALUES(2,1,3,1);
CREATE TABLE t2 ( c1 INTEGER, c2 INTEGER, c3 INTEGER, c4 INTEGER );
INSERT INTO t2 VALUES(1,1,1,1);
INSERT INTO t2 VALUES(2,1,3,1);
COMMIT;
SELECT c1, c3
  FROM ( SELECT c1, c2, c3, c4 FROM t1
         UNION ALL
         SELECT c1, c2, c3, c4 FROM t2
         ORDER BY c1
       ) v1;
C1 C3
---- --
  1  1
  2  1
null  3
null  3
4 rows selected.
```

It gets the correct result after fixing the error as follows.

```
SELECT c1, c3
  FROM ( SELECT c1, c2, c3, c4 FROM t1
         UNION ALL
         SELECT c1, c2, c3, c4 FROM t2
         ORDER BY c1
       ) v1;
C1 C3
-- --
  1  1
  1  1
  2  3
  2  3
```



4 rows selected.

## Workaround

The patch is required.

**ISSUE-4642** If an offline member exists, it creates a pusher and performs the remote join even when it is possible to perform the remote join without the pusher.

## Description

If an offline member exists, it creates a pusher and performs the remote join even when it is possible to perform the remote join without the pusher.

## Symptom

If a member of LC table (g1n2) becomes offline in the following example, then a pusher is created when performing the remote join.

```
CREATE TABLE LC ( c1 INTEGER, c2 INTEGER ) CLONED;
CREATE TABLE RS ( sk INTEGER, c2 INTEGER ) SHARDING BY (sk);
\explain plan
SELECT
    LC.c1
    , RS.sk
FROM LC
    , RS
WHERE LC.c1 = RS.sk
ORDER BY 1
;
>>> start print plan
< Execution Plan >
```

IDX	NODE DESCRIPTION
0	SELECT STATEMENT
1	QUERY BLOCK ("\$_QB_IDX_2")
2	MULTIPLE CLUSTER
3	CLUSTER PUSHER ("\$_NI_8")
4	TABLE ACCESS ("LC")

```

| 5 |          SELECT STATEMENT          |
| 6 |          QUERY BLOCK ("SQB_IDX_2") |
| 7 |          SORT INSTANT              |
| 8 |          HASH JOIN (INNER JOIN)    |
| 9 |          TABLE ACCESS ("RS" AS _A2) |
| 10 |          HASH JOIN INSTANT         |
| 11 |          PUSHER TABLE ACCESS ("_$_NI_8" AS _A1) |
=====
1 - TARGET : $_NI_8.C1, RS.SK
2 - SQL : SELECT /*+ USE_ORDER_SORT KEEP_JOINED_TABLE USE_HASH_IN( _A1, 10 ) FULL( _A2
) FULL( _A1 ) */ "_A1"."C1", "_A2"."SK" FROM ( "PUBLIC"."RS"@LOCAL AS "_A2" INNER JOIN
"SESSION_SCHEMA"."$_NI_8"@LOCAL AS "_A1" ON "_A1"."C1" = "_A2"."SK") ALIAS "_A3" ORDER BY
"_A1"."C1" ASC NULLS LAST
      TARGET DOMAIN : G1(G1N1,G1N2) 0 rows, G2(G2N1,G2N2) 0 rows, G3(G3N1,G3N2) 0 rows
      MERGE SORTING
      SORT KEY : $_NI_8.C1
3 - SQL : DECLARE INSTANT TABLE "SESSION_SCHEMA"."$_NI_8" ( "C1" NUMBER(10, 0) )
      COLUMN : LC.C1 AS C1
      SHARDED : LC.C1
      TARGET DOMAIN : G1(G1N1,G1N2) 0 rows, G2(G2N1,G2N2) 0 rows, G3(G3N1,G3N2) 0 rows
4 - CLONED
      READ COLUMN : LC.C1
6 - TARGET : _A1.C1, _A2.SK
7 - SORT KEY : "_A1.C1 ASC NULLS LAST"
      RECORD COLUMN : _A2.SK
      READ KEY COLUMN : _A1.C1
      READ RECORD COLUMN : _A2.SK
8 - JOINED COLUMN : _A1.C1, _A2.SK
9 - HASH SHARD ( # 3 )
      READ COLUMN : _A2.SK
10 - HASH KEY : _A1.C1
      READ KEY COLUMN : _A1.C1
      HASH FILTER : _A1.C1 = _A2.SK
11 - READ COLUMN : _A1.C1
<<< end print plan

```

The remote join is available without a pusher even when a member of LC table (g1n2) is offline after fixing the error as follows.

```

\explain plan
SELECT

```

```

        LC.c1
    , RS.sk
FROM LC
    , RS
WHERE LC.c1 = RS.sk
ORDER BY 1
;

```

< Execution Plan >

```

=====
|  IDX  |  NODE DESCRIPTION  |
-----
|   0   |  SELECT STATEMENT  |
|   1   |    QUERY BLOCK ("SQB_IDX_2")  |
|   2   |      MULTIPLE CLUSTER  |
|   3   |      SELECT STATEMENT  |
|   4   |        QUERY BLOCK ("SQB_IDX_2")  |
|   5   |          SORT INSTANT  |
|   6   |          HASH JOIN (INNER JOIN)  |
|   7   |            TABLE ACCESS ("LC" AS _A2)  |
|   8   |            HASH JOIN INSTANT  |
|   9   |              TABLE ACCESS ("RS" AS _A1)  |
=====

```

```

1 - TARGET : LC.C1, RS.SK
2 - SQL : SELECT /*+ USE_ORDER_SORT KEEP_JOINED_TABLE USE_HASH_IN( _A1, 10 ) FULL( _A2
) FULL( _A1 ) */ "_A2"."C1", "_A1"."SK" FROM ( "PUBLIC"."LC"@LOCAL AS "_A2" INNER JOIN
"PUBLIC"."RS"@LOCAL AS "_A1" ON "_A1"."SK" = "_A2"."C1") ALIAS "_A3" ORDER BY "_A2"."C1" ASC
NULLS LAST

```

TARGET DOMAIN : G1(G1N1) 0 rows, G2(G2N1,G2N2) 0 rows, G3(G3N1,G3N2) 0 rows

MERGE SORTING

SORT KEY : LC.C1

- ```

4 - TARGET : _A2.C1, _A1.SK
5 - SORT KEY : "_A2.C1 ASC NULLS LAST"
   RECORD COLUMN : _A1.SK
   READ KEY COLUMN : _A2.C1
   READ RECORD COLUMN : _A1.SK
6 - JOINED COLUMN : _A2.C1, _A1.SK
7 - CLONED
   READ COLUMN : _A2.C1
8 - HASH KEY : _A1.SK
   READ KEY COLUMN : _A1.SK
   HASH FILTER : _A1.SK = _A2.C1

```

```

9 - HASH SHARD ( # 3 )
    READ COLUMN : _A1.SK
<<< end print plan

```

## Workaround

The patch is required.

## **ISSUE-4678** gpec processes SELECT statement as SELECT INTO statement.

### Description

SELECT statement and SELECT INTO statement of the embedded SQL should be processed differently. However, gpec processes SELECT statement of the embedded SQL as SELECT INTO statement, then the program is intermittently and abnormally terminated.

### Symptom

gpec was supposed to process the following SQL statement as SELECT statement, but it processed it as SELECT INTO statement because of the garbage value.

```
EXEC SQL SELECT * FROM DUAL;
```

## Workaround

Use INTO clause in SELECT statement.

## 21c.1.17 Patch Notes

### **ISSUE-4594** If a query set exists in the subquery while performing NOT IN subquery unnesting, then the system is abnormally terminated.

#### Description

If a query set exists in the subquery while performing NOT IN subquery unnesting, then the system is abnormally terminated.

## Symptom

The following query abnormally terminates the system.

```
gSQL> CREATE TABLE r ( r_c1 INTEGER PRIMARY KEY, r_c2 INTEGER );
Table created.
gSQL> CREATE TABLE s ( s_c1 INTEGER PRIMARY KEY, s_c2 INTEGER );
Table created.
gSQL> CREATE TABLE t ( t_c1 INTEGER PRIMARY KEY, t_c2 INTEGER );
Table created.
gSQL> CREATE TABLE u ( u_c1 INTEGER PRIMARY KEY, u_c2 INTEGER );
Table created.
gSQL> commit;
Commit complete.
gSQL> \EXPLAIN PLAN
SELECT *
  FROM r
 WHERE r_c1 NOT IN ( SELECT s_c1 FROM s
                    UNION ALL
                    SELECT t_c1 FROM t
                    UNION ALL
                    SELECT u_c1 FROM u
                    )
;
```

It is normally operated after fixing the error.

```
gSQL> \EXPLAIN PLAN
SELECT *
  FROM r
 WHERE r_c1 NOT IN ( SELECT s_c1 FROM s
                    UNION ALL
                    SELECT t_c1 FROM t
                    UNION ALL
                    SELECT u_c1 FROM u
                    )
;    2    3    4    5    6    7    8    9   10
no rows selected.
>>> start print plan
< Execution Plan >
=====
|  IDX  |  NODE DESCRIPTION  |
```

```

-----
0	SELECT STATEMENT
1	QUERY BLOCK ("QB_IDX_2")
2	HASH JOIN (ANTI SEMI)
3	TABLE ACCESS ("R")
4	HASH JOIN INSTANT (UNIQUE)
5	INLINE_VIEW ("V6")
6	QUERY BLOCK ("QB_IDX_6")
7	UNION-ALL
8	QUERY BLOCK ("QB_IDX_9")
9	INDEX ACCESS ("S", "S_PRIMARY_KEY_INDEX")
10	QUERY BLOCK ("QB_IDX_12")
11	INDEX ACCESS ("T", "T_PRIMARY_KEY_INDEX")
12	QUERY BLOCK ("QB_IDX_15")
13	INDEX ACCESS ("U", "U_PRIMARY_KEY_INDEX")
-----

```

```

=====
1 - TARGET : R.R_C1, R.R_C2
2 - JOINED COLUMN : R.R_C1, R.R_C2
3 - READ COLUMN : R.R_C1, R.R_C2
4 - HASH KEY : V6.S_C1
   READ KEY COLUMN : V6.S_C1
   HASH FILTER : V6.S_C1 = R.R_C1
   FETCH ONE ROW
5 - COLUMN : S_C1 AS S_C1
6 - TARGET : S_C1
7 - SET TARGET : S_C1
8 - TARGET : S.S_C1
9 - READ INDEX COLUMN : S.S_C1
10 - TARGET : T.T_C1
11 - READ INDEX COLUMN : T.T_C1
12 - TARGET : U.U_C1
13 - READ INDEX COLUMN : U.U_C1

```

```
<<< end print plan
```

## Workaround

```

gSQL> \EXPLAIN PLAN
SELECT *
FROM r
WHERE r_c1 NOT IN ( SELECT /*+ NO_UNNEST */ s_c1 FROM s
                  UNION ALL

```

```

        SELECT t_c1 FROM t
        UNION ALL
        SELECT u_c1 FROM u
    )
;

```

**ISSUE-4588** It is modified to return NULL for the compatibility with Oracle when *no data found* error occurs in the function referenced from SQL.

## Description

If *no data found* error occurs in the function referenced from SQL, then it returns NULL.

## Symptom

Previously, if *no data found* error occurred in the function referenced from SQL, then it returned an error.

```

gSQL> CREATE TABLE t1( c1 INTEGER );
Table created.
gSQL> INSERT INTO t1 VALUES( 1 );
1 row created.
gSQL> COMMIT;
Commit complete.
gSQL>
CREATE OR REPLACE FUNCTION func1 RETURN INTEGER AS
    v1 INTEGER;
BEGIN
    SELECT c1 INTO v1 FROM t1 WHERE c1 = 2;
    RETURN v1;
END;
/
Function created.
gSQL> SELECT func1 FROM DUAL;
ERR-2F000(17045): no data found :
    SELECT c1 INTO v1 FROM t1 WHERE c1 = 2;
*
ERROR at line 4:
ERROR at FUNCTION("FUNC1")

```

## Workaround

```

gSQL> CREATE TABLE t1( c1 INTEGER );
Table created.
gSQL> INSERT INTO t1 VALUES( 1 );
1 row created.
gSQL> COMMIT;
Commit complete.
gSQL> CREATE OR REPLACE FUNCTION func1 RETURN INTEGER AS
    v1 INTEGER;
BEGIN
    SELECT c1 INTO v1 FROM t1 WHERE c1 = 2;
    RETURN v1;
EXCEPTION WHEN NO_DATA_FOUND THEN
    RETURN NULL;
END;
/
Function created.
gSQL> SELECT func1 FROM DUAL;
FUNC1
-----
null
1 row selected.

```

**ISSUE-4609** When using two or more subquery expressions including a join combine, then a segment fault occurs.

### Description

When referring to the information of the subquery expression in the statement in which two or more subquery expressions including a join combine are used, then a segment fault occurs.

The error occurred in the following clauses.

- TARGET clause
- WHERE clause
- HAVING clause
- ORDER BY clause



## Symptom

When building the information to refer to the subquery expression in the clause including the subquery expression, then it can not find the related expression, so it never stops searching for the expression. Therefore, the segment fault occurs.

```

CREATE TABLE T1(
    C1 NUMBER,
    C2 NUMBER,
    C3 NUMBER,
    C4 NUMBER );
CREATE TABLE T2(
    C1 NUMBER,
    C2 NUMBER,
    C3 NUMBER,
    C4 NUMBER );
--# Segment Fault
SELECT
    (
        SELECT t1.c1
        FROM T1
            INNER
            JOIN
            T2
            ON ( t1.c3 = t2.c2 OR t1.c3 = t2.c3 )
    )
, (
    SELECT t1.c1
    FROM T1
        INNER
        JOIN
        T2
        ON ( t1.c3 = t2.c2 OR t1.c3 = t2.c3 )
    ) AS DS2
FROM dual;

```

## Workaround

The patch is required.

**ISSUE-4589** Complex view merging was executed even though SELECT FOR UPDATE, UPDATE, DELETE does not support the complex view merging.

## Description

Complex view merging was executed even though SELECT FOR UPDATE, UPDATE, DELETE does not support the complex view merging.

## Symptom

The complex view merging should not be executed for the following query. However, the complex view merging is executed after the subquery unnesting, so the server is abnormally terminated.

```
DROP TABLE IF EXISTS t1;
CREATE TABLE t1
(
  c1 INTEGER
, c2 INTEGER
, c3 INTEGER
, c4 INTEGER
);
COMMIT;
UPDATE t1
  SET c1 = 1
 WHERE ( c1, c2, c3, c4 )
    IN ( SELECT c1, c2, c3, c4
        FROM t1
        GROUP BY c1, c2, c3, c4
    );
```

## Workaround

The patch is required.

**ISSUE-4575** The same SQL statements are redundantly cached in an embedded SQL.

## Description

The embedded SQL caches DML and the query statement, then recycles them when using the same SQL. If char pointer is used as the host variable, then the same SQL statements are redundantly cached.

## Symptom

If char pointer is used as the host variable as follows and the string length of this char pointer is changed, then SQL statement is newly created.

```
void func(char * data)
{
    EXEC SQL BEGIN DECLARE SECTION;
    char * strPtr;
    EXEC SQL END DECLARE SECTION;
    strPtr = data;
    EXEC SQL DELETE FROM TEST WHERE C1 = :strPtr;
    if(sqlca.sqlcode == 0 )
        ....
}
```

## Workaround

Use char array as the host variable instead of char pointer.

**ISSUE-4566** It can not process the overflow even when the number of digits increased after the rounding off while converting the numeric type to NUMBER type.

## Description

It can not process the overflow even when the number of digits increased after the rounding off while converting the numeric type to NUMBER type.

## Symptom

The following query was supposed to cause an overflow error.

```
gSQL> SELECT CAST( 999999999.9 AS NUMBER(10,0)) FROM dual;
CAST( 999999999.9 AS NUMBER(10,0))
-----
10000000000
```

1 row selected.

## Workaround

Convert it to NUMBER type after convert it to the character type.

```
gSQL> SELECT CAST( TO_CHAR( 999999999.9 ) AS NUMBER(10,0) ) FROM dual;
ERR-22003(12060): data is outside the range of the data type to which the number is being
converted :
SELECT CAST( TO_CHAR( 999999999.9 ) AS NUMBER(10,0) ) FROM dual
      *
ERROR at line 1:
```

## **ISSUE-4559** The trace log is output as TRACE\_LONG\_RUN\_CURSOR even when the cursor does not exist in SELECT INTO statement.

### Description

TRACE\_LONG\_RUN\_CURSOR property records the long run cursor which exceeds the specified time on the trace log. However, the trace log is output as TRACE\_LONG\_RUN\_CURSOR even though SELECT INTO statement does not require the cursor, and this error has been fixed.

### Symptom

If SELECT INTO statement fails as follows, it is determined as TRACE\_LONG\_RUN\_CURSOR so it records the trace log.

```
gSQL> CREATE TABLE r ( c1 INTEGER );
Table created.
gSQL> INSERT INTO r VALUES ( 1 );
1 row created.
--# It is the long run cursor trace which takes more than 1 second
gSQL> ALTER SYSTEM SET TRACE_LONG_RUN_CURSOR = 1000;
System altered.
gSQL> \var v1 INTEGER
gSQL> \prepare sql SELECT c1 INTO :v1 FROM r WHERE c1 = 1 FOR UPDATE;
SQL prepared.
--# It is not recorded as TRACE_LONG_RUN_CURSOR on the trace log.
gSQL> \exec
V1
--
1
```

```

1 row selected.
gSQL> INSERT INTO r VALUES ( 1 );
1 row created.
--# Execute after 2 seconds.
--# It is recorded as TRACE_LONG_RUN_CURSOR on the trace log.
gSQL> \exec
ERR-42000(16289): into clause can have only one row

```

## Workaround

The patch is required.

**ISSUE-4549** When performing ADD MEMBER in a specific topology situation, an invalid member is changed to a domain coordinator.

## Description

If an added member is changed to a domain coordinator when performing ADD MEMBER, then the transaction waiting for the response from the existing domain coordinator may hang. Therefore, be cautious not to change the coordinator's location when performing ADD MEMBER.

## Symptom

The global coordinator is located in the group G2, and G1N1 is ADDED at G1N2 which is a domain coordinator of the group G1.

```
ALTER CLUSTER GROUP G1 ADD CLUSTER MEMBER G1N1 HOST '127.0.0.1' PORT 11150;
```

If the domain coordinator is changed from G1N2 to a newly added member, G1N1, due to ADD MEMBER, then the transactions waiting for the response from the existing domain coordinator, G1N2, may hang.

## Workaround

Perform ADD MEMBER at the global coordinator.

**ISSUE-4546** If it is performed in a local method when performing ORDER BY LIMIT query in cluster environment, then the result has an error.

## Description

If it is performed in a local method when performing ORDER BY LIMIT query in cluster environment, then the result has an error.

The same error occurs when performing GROUP BY LIMIT or DISTINCT LIMIT.

## Symptom

```
--# result: success
CREATE TABLE r ( sk INTEGER, nk INTEGER ) SHARDING BY ( sk );
COMMIT;
--# result: success
INSERT INTO r VALUES(1111, 1);
INSERT INTO r VALUES(1111, 1);
INSERT INTO r VALUES(1111, 1);
INSERT INTO r VALUES(1111, 1);
INSERT INTO r VALUES(1111, 2);
INSERT INTO r VALUES(2222, 1);
INSERT INTO r VALUES(2222, 1);
INSERT INTO r VALUES(2222, 1);
INSERT INTO r VALUES(2222, 1);
INSERT INTO r VALUES(2222, 3);
INSERT INTO r VALUES(3333, 1);
INSERT INTO r VALUES(3333, 1);
INSERT INTO r VALUES(3333, 1);
INSERT INTO r VALUES(3333, 1);
INSERT INTO r VALUES(3333, 4);
COMMIT;
```

When performing ORDER BY LIMIT statement in a local method as follows for the table above, then the result has an error.

```
SELECT /*+ LOCAL_ORDER */
      nk
FROM r
ORDER BY nk DESC
LIMIT 3;
NK
--
2
1
1
3 rows selected.
```

The correct result is output as follows after fixing the error.

```
SELECT /*+ LOCAL_ORDER */
      nk
FROM r
ORDER BY nk DESC
LIMIT 3;
NK
--
4
3
2
3 rows selected.
```

## Workaround

Use rownum instead of limit.

```
gSQL>
SELECT *
FROM ( SELECT /*+ LOCAL_ORDER */
      nk
      FROM r
      ORDER BY nk DESC
      )
WHERE rownum < 4;
NK
--
4
3
2
3 rows selected.
```

**ISSUE-4537** When performing ADD MEMBER after the incorrect DROP TABLESPACE statement succeeds, then the new member is abnormally terminated.

## Description

If performing ADD MEMBER when DROP TABLESPACE statement succeeds though it was supposed to fail, then the newly added cluster member is abnormally terminated, so ADD MEMBER fails.

It is modified to cause an error when the DROP TABLESPACE's target tablespace was set as the user's default tablespace.

```
gSQL> CREATE USER u1 IDENTIFIED BY u1
        TEMPORARY TABLESPACE temp_tbs;
User created.
gSQL> DROP TABLESPACE temp_tbs CASCADE;
ERR-42000(16133): cannot drop tablespace: "TEMP_TBS" is default tablespace of user "U1"
```

To drop the tablespace, modify the user's default tablespace as follows first then drop it.

```
gSQL> ALTER USER u1 TEMPORARY TABLESPACE mem_temp_tbs;
User altered.
gSQL> DROP TABLESPACE temp_tbs CASCADE;
Tablespace dropped.
```

## Symptom

DROP TABLESPACE succeeds as follows though the user's default tablespace was unable to drop.

```
gSQL> CREATE USER u1 IDENTIFIED BY u1
        TEMPORARY TABLESPACE temp_tbs;
User created.
gSQL> DROP TABLESPACE temp_tbs CASCADE;
Tablespace dropped.
```

Then, if a new cluster member is added as follows, then the new member(g2n3) is abnormally terminated, so ADD MEMBER fails.

```
gSQL> ALTER CLUSTER GROUP g2 ADD CLUSTER MEMBER g2n3 HOST '127.0.0.1' PORT 12350;
```

## Workaround

Before performing ADD MEMBER, it is required to find the user violating DROP TABLESPACE integrity and modify the user's default tablespace as follows.

If the result of the following query exists, then it is required to modify the user's default tablespace.

```
SELECT auth.authorization_name
       FROM definition_schema.authorizations@local AS auth
          , definition_schema.users@local AS usr
       WHERE auth.auth_id = usr.auth_id
          AND NOT EXISTS ( SELECT *
```



```

FROM definition_schema tablespaces@local AS tbs
WHERE tbs.tablespace_id = usr.default_data_tablespace_id );

```

If the result of the following query exists, then it is required to modify the user's temporary tablespace.

```

SELECT auth.authorization_name
FROM definition_schema.authorizations@local AS auth
, definition_schema.users@local AS usr
WHERE auth.auth_id = usr.auth_id
AND NOT EXISTS ( SELECT *
FROM definition_schema tablespaces@local AS tbs
WHERE tbs.tablespace_id = usr.default_temp_tablespace_id );

```

If the result of the following query exists, then it is required to modify the user's index tablespace.

```

SELECT auth.authorization_name
FROM definition_schema.authorizations@local AS auth
, definition_schema.users@local AS usr
WHERE auth.auth_id = usr.auth_id
AND NOT EXISTS ( SELECT *
FROM definition_schema tablespaces@local AS tbs
WHERE tbs.tablespace_id = usr.default_index_tablespace_id )
;

```

## 21c.1.16 Patch Notes

**ISSUE-4500** If performing the index scan by using another OR condition when the join condition includes OR condition, then the query waits infinitely.

### Description

When the join combine method is selected by the join condition including OR condition, and the column included in the join combine is referenced in the relation to which another join belongs, then it waits infinitely.

### Symptom

When referring to the column included in the join which consists of join combine as follows, then it cannot find the column information, so it waits infinitely.

```

gSQL> CREATE TABLE T1( C1 INT, C2 INT );
Table created.
gSQL> CREATE INDEX IDX_T1_C1 ON T1( C1 );
Index created.
gSQL> CREATE INDEX IDX_T1_C2 ON T1( C2 );
Index created.
gSQL> INSERT INTO T1 VALUES ( 1, 1 );
1 row created.
--# Infinite waiting
gSQL> SELECT *
  FROM T1 A, T1 B
 WHERE ( A.C1 = B.C1 OR A.C1 = B.C2 )
  AND EXISTS( SELECT 1
              FROM T1 C
              WHERE ( C.C1 = A.C1 OR C.C2 = A.C1 ) );

```

## Workaround

Use NO\_USE\_JOIN\_COMBINE hint as follows so that JOIN COMBINE would not be configured.

```

gSQL> SELECT /*+ NO_USE_JOIN_COMBINE( A ) */ *
  FROM T1 A, T1 B
 WHERE ( A.C1 = B.C1 OR A.C1 = B.C2 )
  AND EXISTS( SELECT 1
              FROM T1 C
              WHERE ( C.C1 = A.C1 OR C.C2 = A.C1 ) );

C1 C2 C1 C2
-- -- -- --
 1  1  1  1
1 rows selected.

```

## 21c.1.15 Patch Notes

**ISSUE-4480** When defining %TYPE which refers to the column whose reserved word is the column name, then an error occurs.

### Description

When defining %TYPE which refers to the column whose reserved word is the column name, then an error occurs.

## Symptom

An error occurs because it can not find the column information though OFFSET column exists in the table as follows.

```
gSQL> CREATE TABLE t1( "OFFSET" INTEGER, LENGTH INTEGER );
Table created.
gSQL> COMMIT;
Commit complete.
gSQL> CREATE OR REPLACE PROCEDURE proc1( p1 public.t1."OFFSET"%TYPE )
AS
BEGIN
    NULL;
END;
/
ERR-2F000(17012): unknown type name :
CREATE OR REPLACE PROCEDURE proc1( p1 public.t1."OFFSET"%TYPE )
```

## Workaround

The patch is required.

## **ISSUE-4472** When outputting DDL\_DB, the schema privilege DDL is not output.

### Description

If outputting DDL\_DB when two or more schema are created, then only part of them are output and other are not output.

### Symptom

Three schema privilege DDLs should have been created in the example below, but actually only one DDL is created.

```
gSQL> CREATE SCHEMA s1;
Schema created.
gSQL> CREATE SCHEMA s2;
Schema created.
gSQL> CREATE SCHEMA s3;
Schema created.
gSQL> COMMIT;
```

```

Commit complete.
gSQL> CREATE USER u1 IDENTIFIED BY u1 WITHOUT SCHEMA;
User created.
gSQL> CREATE USER u2 IDENTIFIED BY u2 WITHOUT SCHEMA;
User created.
gSQL> CREATE USER u3 IDENTIFIED BY u3 WITHOUT SCHEMA;
User created.
gSQL> COMMIT;
Commit complete.
gSQL> GRANT CREATE TABLE ON SCHEMA s1 TO u1;
Grant succeeded.
gSQL> GRANT CREATE VIEW ON SCHEMA s2 TO u2, u3;
Grant succeeded.
gSQL> COMMIT;
Commit complete.
gSQL> \ddl_db
--#####
--# Database DDL
--#####
SET SESSION AUTHORIZATION "SYS";
COMMENT
    ON DATABASE
    IS 'goldilocks database'
;
COMMIT;
...Ellipsis...
--#####
--# Schema Privilege DDL
--#####
SET SESSION AUTHORIZATION "SYS";
GRANT
    CREATE TABLE ON SCHEMA "S1"
    TO "U1"
;
COMMIT;
--#####
--# Public Synonym DDL
--#####
...Ellipsis...

```

Three schema privilege DDLs are created after solving the problem.

```

gSQL> CREATE SCHEMA s1;
Schema created.
gSQL> CREATE SCHEMA s2;
Schema created.
gSQL> CREATE SCHEMA s3;
Schema created.
gSQL> COMMIT;
Commit complete.
gSQL> CREATE USER u1 IDENTIFIED BY u1 WITHOUT SCHEMA;
User created.
gSQL> CREATE USER u2 IDENTIFIED BY u2 WITHOUT SCHEMA;
User created.
gSQL> CREATE USER u3 IDENTIFIED BY u3 WITHOUT SCHEMA;
User created.
gSQL> COMMIT;
Commit complete.
gSQL> GRANT CREATE TABLE ON SCHEMA s1 TO u1;
Grant succeeded.
gSQL> GRANT CREATE VIEW ON SCHEMA s2 TO u2, u3;
Grant succeeded.
gSQL> COMMIT;
Commit complete.
gSQL> \ddl_db
--#####
--# Database DDL
--#####
SET SESSION AUTHORIZATION "SYS";
COMMENT
    ON DATABASE
    IS 'goldilocks database'
;
COMMIT;
...Ellipsis...
--#####
--# Schema Privilege DDL
--#####
SET SESSION AUTHORIZATION "SYS";
GRANT
    CREATE TABLE ON SCHEMA "S1"
    TO "U1"
;

```

```

COMMIT;
SET SESSION AUTHORIZATION "SYS";
GRANT
    CREATE VIEW ON SCHEMA "S2"
    TO "U2"
;
COMMIT;
SET SESSION AUTHORIZATION "SYS";
GRANT
    CREATE VIEW ON SCHEMA "S2"
    TO "U3"
;
COMMIT;
--#####
--# Public Synonym DDL
--#####
...Ellipsis...

```

## Workaround

Output GRANT information per each schema.

```

gSQL> \ddl_schema s1 GRANT
SET SESSION AUTHORIZATION "SYS";
GRANT
    CREATE TABLE ON SCHEMA "S1"
    TO "U1"
;
COMMIT;
gSQL> \ddl_schema s2 GRANT
SET SESSION AUTHORIZATION "SYS";
GRANT
    CREATE VIEW ON SCHEMA "S2"
    TO "U2"
;
COMMIT;
SET SESSION AUTHORIZATION "SYS";
GRANT
    CREATE VIEW ON SCHEMA "S2"
    TO "U3"
;
COMMIT;

```

**ISSUE-4471** When creating TABLESPACE with DISK TABLESPACE statement which was output with DDL\_DB command, then a syntax error occurs.

## Description

When creating TABLESPACE with CREATE DISK TABLESPACE statement which was output with DDL\_DB command, then a syntax error occurs.

## Symptom

3. Create the tablespace.

```
gSQL> CREATE DISK DATA TABLESPACE disk_test_01 DATAFILE 'DISK_TEST_01.dbf' SIZE 100M;
COMMIT;
```

4. Input `\ddl_db`.

```
gSQL> \ddl_db
--#####
--# Database DDL
--#####
SET SESSION AUTHORIZATION "SYS";
COMMENT
  ON DATABASE
  IS 'goldilocks database'
;
COMMIT;
--#####
--# Tablespace DDL
--#####
SET SESSION AUTHORIZATION "SYS";
CREATE DISK DATA TABLESPACE "DISK_TEST_01"
  DATAFILE
    '/home/product/Gliese/home/g1n1_home/db/DISK_TEST_01.dbf'
  SIZE 104857600 REUSE
  AT "G1N1"
  AUTOEXTEND OFF
,
  '/home/product/Gliese/home/g2n1_home/db/DISK_TEST_01.dbf'
  SIZE 104857600 REUSE
```

```

        AT "G2N1"
        AUTOEXTEND OFF
    ONLINE
    EXTSIZE 262144
;
COMMIT;
... Ellipsis ...

```

5. Input tablespace DDL statement which was output by executing `#ddl_db` command in step 2.

```

gSQL> CREATE DISK DATA TABLESPACE "DISK_TEST_01"
    DATAFILE
        '/home/product/Gliese/home/g1n1_home/db/DISK_TEST_01.dbf'
    SIZE 104857600 REUSE
    AT "G1N1"
    AUTOEXTEND OFF
    ,
        '/home/product/Gliese/home/g2n1_home/db/DISK_TEST_01.dbf'
    SIZE 104857600 REUSE
    AT "G2N1"
    AUTOEXTEND OFF
    ONLINE
    EXTSIZE 262144
;
ERR-42000(40000): syntax error:
    AUTOEXTEND OFF
    ^         ^
Error at line 6

```

## Workaround

Modify the location of `AUTOEXTEND OFF` and `AT <domain_name>` in `CREATE TABLESPACE` statement which was output with `#ddl_db`, then execute it.

```

gSQL> CREATE DISK DATA TABLESPACE "DISK_TEST_01"
    DATAFILE
        '/home/product/Gliese/home/g1n1_home/db/DISK_TEST_01.dbf'
    SIZE 104857600 REUSE
    AUTOEXTEND OFF
    AT "G1N1"
    ,
        '/home/product/Gliese/home/g2n1_home/db/DISK_TEST_01.dbf'

```



```
SIZE 104857600 REUSE
AUTOEXTEND OFF
AT "G2N1"
ONLINE
EXTSIZE 262144
;
Tablespace created.
```

## 21c.1.14 Patch Notes

**ISSUE-4467** When *failed to synchronize replicas* error occurs, then it is output on the trace log.

### Description

When [ERR-56008] *failed to synchronize replicas* error occurs, then it is output on the trace log.

### Symptom

N/A

### Workaround

The patch is required.

## 21c.1.13 Patch Notes

**ISSUE-4454** When TRACE\_LOG\_ID = xxxxx1 is set, the performance time of the query per section is not output on the trace log.

### Description

When TRACE\_LOG\_ID = xxxxx1 is set, the performance time of the query per section is not output on the trace log. The ones place in TRACE\_LOG\_ID is the flag which determines whether to output the performance time per section, and it outputs the time when the value is 1.

## Symptom

When TRACE\_LOG\_ID = xxxxx1 is set, the performance time of the query per section is not output on the trace log.

```
[S][0.000000] SELECT * FROM dual
... Ellipsis ...
< Time Info >
=====
| Module      | Time           | Rate          | Call         |
=====
Parse	0:00:00.000000	0.00 %	1
Validate	0:00:00.000000	0.00 %	1
Cost Opt	0:00:00.000000	0.00 %	1
Code Opt	0:00:00.000000	0.00 %	1
Data Opt	0:00:00.000000	0.00 %	1
Execute	0:00:00.000000	0.00 %	1
Fetch	0:00:00.000000	0.00 %	1
Total	0:00:00.000000	100.00 %	
=====
```

## Workaround

The patch is required.

**ISSUE-4439** If only the column which is not boolean type is specified in WHERE clause, then it may abnormally terminated.

## Description

If only the column which is not boolean type is specified in WHERE clause, then it may abnormally terminated. If it is classified as a physical filter, then it is also a bug even when it is not abnormally terminated.

## Symptom

table\_name in the query below is varchar type and it is classified as a physical filter, then it is abnormally terminated during the process.

```
SELECT table_name
FROM DICTIONARY_SCHEMA.USER_TABLES
WHERE table_name;
```

It is normally operated as follows after fixing the bug, and an error occurs.

```
SELECT table_name
  FROM DICTIONARY_SCHEMA.USER_TABLES
 WHERE table_name;
ERR-22018(12123): data is not boolean literal
```

## Workaround

The patch is required.

**ISSUE-4434** Hang occurs when performing REBALANCE on the member who does not have the rebalance target.

## Description

Hang occurs when performing REBALANCE on the cluster member who does not have the rebalance target table.

## Symptom

Hang occurs when performing TABLE REBALANCE on the node who does not have the rebalance target table.

## Workaround

The patch is required.

## 21c.1.12 Patch Notes

**ISSUE-4410** It supports unnesting the subquery with SET operation.

## Description

Unnesting the subquery with SET operation was not supported but it is now supported owe to this patch.

## Symptom

Unnesting the subquery with SET operation was not supported as follows.

```

\EXPLAIN PLAN
SELECT *
  FROM r
 WHERE r_c1 IN ( SELECT s_c1 FROM s
                 UNION ALL
                 SELECT t_c1 FROM t
                 UNION ALL
                 SELECT u_c1 FROM u
                 )
;
R_C1 R_C2 R_C3 R_C4
-----
   1   1   1   1
1 row selected.
>>> start print plan
< Execution Plan >
=====
|  IDX  |  NODE DESCRIPTION  |
-----|-----|
|   0   |  SELECT STATEMENT  |
|   1   |  QUERY BLOCK ("QB_IDX_2") |
|   2   |  TABLE ACCESS ("R") |
|   3   |  SUB QUERY LIST    |
|   4   |  INLINE_VIEW ("V4") (MATERIALIZED) |
|   5   |  QUERY BLOCK ("QB_IDX_6") |
|   6   |  UNION-ALL        |
|   7   |  QUERY BLOCK ("QB_IDX_9") |
|   8   |  INDEX ACCESS ("S", "S_PRIMARY_KEY_INDEX") |
|   9   |  QUERY BLOCK ("QB_IDX_13") |
|  10   |  INDEX ACCESS ("T", "T_PRIMARY_KEY_INDEX") |
|  11   |  QUERY BLOCK ("QB_IDX_17") |
|  12   |  INDEX ACCESS ("U", "U_PRIMARY_KEY_INDEX") |
=====
1 - TARGET : R.R_C1, R.R_C2, R.R_C3, R.R_C4
2 - READ COLUMN : R.R_C1, R.R_C2, R.R_C3, R.R_C4
   POST FILTER : ( R.R_C1 ) IN ( $V4.S_C1 )
4 - COLUMN : S_C1 AS S_C1
5 - TARGET : S_C1
6 - SET TARGET : S_C1
7 - TARGET : S.S_C1
8 - READ INDEX COLUMN : S.S_C1

```

```

    9 - TARGET : T.T_C1
   10 - READ INDEX COLUMN : T.T_C1
   11 - TARGET : U.U_C1
   12 - READ INDEX COLUMN : U.U_C1
<<< end print plan

```

However, it has been modified to enable the unnesting as follows.

```

\EXPLAIN PLAN
SELECT *
  FROM r
 WHERE r_c1 IN ( SELECT s_c1 FROM s
                UNION ALL
                SELECT t_c1 FROM t
                UNION ALL
                SELECT u_c1 FROM u
                )
;
R_C1 R_C2 R_C3 R_C4
-----
   1   1   1   1
1 row selected.
>>> start print plan
< Execution Plan >
=====
|  IDX  |  NODE DESCRIPTION  |
=====
|   0   |  SELECT STATEMENT  |
|   1   |  QUERY BLOCK ("QB_IDX_2") |
|   2   |  NESTED JOIN (SEMI) |
|   3   |  TABLE ACCESS ("R") |
|   4   |  INLINE_VIEW ("V5") |
|   5   |  QUERY BLOCK ("QB_IDX_6") |
|   6   |  UNION-ALL         |
|   7   |  QUERY BLOCK ("QB_IDX_9") |
|   8   |  INDEX ACCESS ("S", "S_PRIMARY_KEY_INDEX") |
|   9   |  QUERY BLOCK ("QB_IDX_13") |
|  10   |  INDEX ACCESS ("T", "T_PRIMARY_KEY_INDEX") |
|  11   |  QUERY BLOCK ("QB_IDX_17") |
|  12   |  INDEX ACCESS ("U", "U_PRIMARY_KEY_INDEX") |
=====

```

```

1 - TARGET : R.R_C1, R.R_C2, R.R_C3, R.R_C4
2 - JOINED COLUMN : R.R_C1, R.R_C2, R.R_C3, R.R_C4
3 - READ COLUMN : R.R_C1, R.R_C2, R.R_C3, R.R_C4
4 - COLUMN : S_C1 AS S_C1
5 - TARGET : S_C1
6 - SET TARGET : S_C1
7 - TARGET : S.S_C1
8 - READ INDEX COLUMN : S.S_C1
   MIN RANGE : S.S_C1 = {R.R_C1}
   MAX RANGE : S.S_C1 = {R.R_C1}
   FETCH ONE ROW
9 - TARGET : T.T_C1
10 - READ INDEX COLUMN : T.T_C1
    MIN RANGE : T.T_C1 = {R.R_C1}
    MAX RANGE : T.T_C1 = {R.R_C1}
    FETCH ONE ROW
11 - TARGET : U.U_C1
12 - READ INDEX COLUMN : U.U_C1
    MIN RANGE : U.U_C1 = {R.R_C1}
    MAX RANGE : U.U_C1 = {R.R_C1}
    FETCH ONE ROW
<<< end print plan

```

## Workaround

The patch is required.

**ISSUE-4404** The entire system stops due to the rebalancing when performing fail-back the specific node, and this has been resolved.

## Description

If rebalancing when performing fail-back the specific node, then the entire cluster is lock instead of performing x lock the group related to the node. Therefore, it has been modified to lock nodes related to the rebalance only.

## Symptom

The node table which is not related to REBALANCE is X-LOCKed, so the table is not available.

## Workaround

The patch is required.

## 21c.1.11 Patch Notes

**ISSUE-4370** If the filter including the case function is used in where clause when performing the outer join, then it may abnormally terminate.

### Description

If the filter including the case function is used in where clause when performing the outer join, then it may abnormally terminate.

### Symptom

It checks whether outer join operation elimination is allowed when performing the outer join. In this case, if the case function exists in the where clause, then it is abnormally terminated.

```
DROP TABLE r;
DROP TABLE s;
COMMIT;
CREATE TABLE r ( r_c1 INTEGER, r_c2 INTEGER );
INSERT INTO r VALUES ( 1, 1 );
COMMIT;
CREATE TABLE s ( s_c1 INTEGER, s_c2 INTEGER );
INSERT INTO s VALUES ( 1, 1 );
COMMIT;
\explain plan
SELECT *
  FROM r LEFT OUTER JOIN s ON r_c1 = s_c1
 WHERE CASE WHEN s_c1 > 0 THEN 1 ELSE 0 END = 1
;
R_C1 R_C2 S_C1 S_C2
---- ---- ---- ----
   1   1   1   1
1 row selected.
>>> start print plan
```

< Execution Plan >

```

=====
|  IDX  |  NODE DESCRIPTION  |
-----
|   0   |  SELECT STATEMENT  |
|   1   |    QUERY BLOCK ("SQB_IDX_2")
|   2   |      HASH JOIN (INNER JOIN)
|   3   |        TABLE ACCESS ("R")
|   4   |          HASH JOIN INSTANT
|   5   |            TABLE ACCESS ("S")
=====

1 - TARGET : R.R_C1, R.R_C2, S.S_C1, S.S_C2
2 - JOINED COLUMN : R.R_C1, R.R_C2, S.S_C1, S.S_C2
3 - READ COLUMN : R.R_C1, R.R_C2
4 - HASH KEY : S.S_C1
   RECORD COLUMN : S.S_C2
   READ KEY COLUMN : S.S_C1, S.S_C2
   HASH FILTER : S.S_C1 = R.R_C1
5 - READ COLUMN : S.S_C1, S.S_C2
   LOGICAL FILTER : CASE WHEN S.S_C1 > 0 THEN 1 ELSE 0 END = 1
<<< end print plan

```

## Workaround

The patch is required.

## 21c.1.10 Patch Notes

**ISSUE-4285** It has been changed to enable the filter including the stored function to perform the index join.

### Description

The filter which includes the stored function or the non-deterministic built-in function (e.g. RANDOM) could not be used as a filter determining the join method. However, it has been changed to enable it.

### Symptom



The following is an example of obtaining the result by applying  $s\_c1 = func1(r\_c1)$  after performing the full nested join even when the join condition exists.

```

DROP TABLE r;
DROP TABLE s;
COMMIT;
CREATE TABLE r ( r_c1 INTEGER, r_c2 INTEGER );
COMMIT;
INSERT INTO r VALUES ( 1, 1 );
COMMIT;
CREATE TABLE s ( s_c1 INTEGER, s_c2 INTEGER );
CREATE UNIQUE INDEX idx_s ON s( s_c1 );
COMMIT;
INSERT INTO s VALUES ( 1, 1 );
COMMIT;
CREATE OR REPLACE FUNCTION func1( a1 INTEGER ) RETURN INTEGER
AS
    v1 INTEGER;
BEGIN
    SELECT 0 + a1 INTO v1
    FROM dual;
    RETURN v1;
END;
/
\explain plan
SELECT *
  FROM r, s
 WHERE s_c1 = func1( r_c1 )
    AND r_c2 = 1
;
R_C1 R_C2 S_C1 S_C2
-----
   1   1   1   1
1 row selected.
>>> start print plan
< Execution Plan >
=====
|  IDX  |  NODE DESCRIPTION                                |
-----|-----|
|    0  |  SELECT STATEMENT                                |
|    1  |  QUERY BLOCK ("QB_IDX_2")                        |

```

```

2	NESTED JOIN (INNER JOIN)
3	TABLE ACCESS ("R")
4	TABLE ACCESS ("S")
=====
1 - TARGET : R.R_C1, R.R_C2, S.S_C1, S.S_C2
2 - JOINED COLUMN : S.S_C1, R.R_C1, R.R_C2, S.S_C2
   POST WHERE FILTER : S.S_C1 = "FUNC1"( R.R_C1 )
3 - READ COLUMN : R.R_C1, R.R_C2
   PHYSICAL FILTER : R.R_C2 = 1
4 - READ COLUMN : S.S_C1, S.S_C2
<<< end print plan

```

The following is a result of performing the same query after the modification. It has been changed to perform the index nested loop join.

```

gSQL> \explain plan
SELECT *
  FROM r, s
 WHERE s_c1 = func1( r_c1 )
    AND r_c2 = 1
;

R_C1 R_C2 S_C1 S_C2
-----
   1   1   1   1
1 row selected.
>>> start print plan
< Execution Plan >
=====
|  IDX  |  NODE DESCRIPTION  |
-----|-----|
|   0   |  SELECT STATEMENT  |
|   1   |  QUERY BLOCK ("SQB_IDX_2") |
|   2   |  NESTED JOIN (INNER JOIN) |
|   3   |  TABLE ACCESS ("R") |
|   4   |  INDEX ACCESS ("S", "IDX_S") |
=====
1 - TARGET : R.R_C1, R.R_C2, S.S_C1, S.S_C2
2 - JOINED COLUMN : R.R_C1, R.R_C2, S.S_C1, S.S_C2
3 - READ COLUMN : R.R_C1, R.R_C2
   PHYSICAL FILTER : R.R_C2 = 1

```

```

4 - READ INDEX COLUMN : S.S_C1
   READ TABLE COLUMN : S.S_C2
     MIN RANGE : S.S_C1 = "FUNC1"({R.R_C1} )
     MAX RANGE : S.S_C1 = "FUNC1"({R.R_C1} )
   FETCH ONE ROW
<<< end print plan

```

## Workaround

The patch is required.

## 21c.1.9 Patch Notes

### **ISSUE-3496** It supports IPC connection.

#### Description

It supports IPC connection for the server and ODBC client which are located in the same device.

#### Symptom

N/A

#### Workaround

The patch is required.

### **ISSUE-4357** Boolean type has been added to the connection property of JDBC so that the effective value has been changed.

#### Description

**Connection Properties** whose effective values are {true, false}, {on, off}, {0, 1} exist in JDBC. It has been changed to regard those connection properties as boolean type to process their effective values such as true, on, yes, 1 / false, off, no and 0 as the equivalent effective value.

#### Symptom

The effective value of `statement_pool_on`, the connection property, is either "1" or "0". If another value is used, then an error occurs. The effective value of `include_synonyms` is either "true" or "false", and the effective value of `trace_log` is either "on" or any string. What's in common for those connection properties is

that the effective value is used as boolean type. Therefore, it is changed to use true, on, yes, 1 / false, off, no, 0 as the equivalent effective value to prevent the confusion in the boolean type connection properties.

## Workaround

The patch is required.

## **ISSUE-4355** FAILOVER\_ROUTING\_POLICY property has been added in ODBC.

### Description

FAILOVER\_ROUTING\_POLICY property has been added in ODBC.

### Symptom

Previously, if an error occurs in the last server of ALTERNATE\_SERVERS, then the failover is operated in the first connected server. Therefore, FAILOVER\_ROUTING\_POLICY property has been added in ODBC so that at the failover ends when the error occurs in the last server of ALTERNATE\_SERVERS.

## Workaround

The patch is required.

## **ISSUE-4354** When the signal is periodically generated by creating POSIX timer, then login timeout and connection timeout are not normally operated in ODBC.

### Description

When the signal is periodically generated by creating POSIX timer, then login timeout and connection timeout are not normally operated in ODBC.

### Symptom

If the signal is periodically received from POSIX timer while waiting as long as the timeout set through SQL\_ATTR\_LOGIN\_TIMEOUT and SQL\_ATTR\_CONNECTION\_TIMEOUT in ODBC, then it waits longer than the timeout set.

## Workaround

Do not use POSIX timer while using login timeout and connection timeout.

## 21c.1.8 Patch Notes

**ISSUE-4348** Failover is operated when login timeout and connection timeout occur in ODBC environment.

### Description

If timeout occurs when `SQL_ATTR_LOGIN_TIMEOUT` and `SQL_ATTR_CONNECTION_TIMEOUT` are set, the failover is not operated in server of `alternate_servers`.

### Symptom

If login timeout and connection timeout occur in ODBC environment, then failover is not operated but it immediately returns an error.

### Workaround

The patch is required.

**ISSUE-4316** When executing `V$STATEMENT`, then intermittently *datetime field overflow* error occurs.

### Description

If a session is dead or terminated while executing `V$STATEMENT`, then it may import the garbage value. *datetime field overflow* occurs because it reads the garbage value and tries to output it.

### Symptom

When executing `V$STATEMENT` while executing multiple statement, then intermittently *datetime field overflow* error occurs.

### Workaround

Execute it again until the correct value is output.

## 21c.1.7 Patch Notes

**ISSUE-4327** When simultaneously executing the restart recovery on multiple members in cluster environment, then it fails to join due to the wrong recovery of *in doubt* transaction.

### Description

When the cluster member in cluster environment executes the restart recovery, then it also recovers *in doubt* transaction in PREPARE status. *in doubt* transaction is recovered by requesting the transaction result to other cluster members on MOUNT or above phase, and collecting them, then COMMIT or ROLLBACK them.

If two members simultaneously recover the same *in doubt* transaction, then the process to set and acquire the transaction status and SCN is not atomic. Therefore, the system SCN is set to the invalid value, and it fails to join.

### Symptom

The member can not join the cluster database because the system SCN is set to the invalid value.

### Workaround

Drop the cluster member whose SCN is wrong from the cluster, or add a new member.

## 21c.1.6 Patch Notes

**ISSUE-5678** If NULL constant is used in any SQL statement used in PSM, then it may access the wrong memory.

### Description

If PSM variable and NULL value are used together in SQL statement within PSM, then it accesses the wrong memory.

### Symptom

If the following query is executed, then the server is abnormally terminated.

```

gSQL> DECLARE
    v1 NUMBER := 1;
BEGIN
    INSERT INTO t1 ( c1, c2, c3, c4 )
        VALUES ( 1, null, null, null );
END;
/

```

## Workaround

Do not use NULL and PSM variable together in SQL statement.

```

gSQL>
DECLARE
    v1 NUMBER;
    v2 NUMBER;
    v3 NUMBER;
    v4 NUMBER;
BEGIN
    v1 := 1;
    v2 := null;
    v3 := null;
    v4 := null;

    INSERT INTO t1 ( c1, c2, c3, c4 )
        VALUES( v1, v2, v3, v4 );
END;
/

```

**ISSUE-4286** If a function argument has an error when executing the function which selects the result by comparing conditions, then it performs the argument even when it is not required, so an error occurs.

## Description

When executing the function which selects the result by comparing conditions such as CASE2, DECODE, NVL, NVL2, COALESCE, then it selects the result by comparing conditions after executing all function arguments. Therefore, if a function argument has an error, then an error occurs for the argument which is not required to be executed.

## Symptom

```
gSQL> CREATE TABLE r ( c1 INTEGER );
Table created.
gSQL> INSERT INTO r VALUES ( 0 );
1 row created.
gSQL> COMMIT;
Commit complete.
gSQL>
SELECT CASE2( c1 <> 0, 100/c1, c1 ) AS result
FROM r;
ERR-22012(12122): divisor is equal to zero :
CASE2( c1 <> 0, 100/c1, c1 ) AS result
      *
ERROR at line 2:
gSQL>
SELECT DECODE( c1, 0, c1, 100/c1 ) AS result
FROM r;
ERR-22012(12122): divisor is equal to zero :
DECODE( c1, 0, c1, 100/c1 ) AS result
      *
ERROR at line 2:
gSQL>
SELECT NVL( c1, 100/c1 ) AS result
FROM r;
ERR-22012(12122): divisor is equal to zero :
NVL( c1, 100/c1 ) AS result
      *
ERROR at line 2:
gSQL>
SELECT NVL2( c1, c1, 100/c1 ) AS result
FROM r;
ERR-22012(12122): divisor is equal to zero :
NVL2( c1, c1, 100/c1 ) AS result
      *
ERROR at line 2:
gSQL>
SELECT COALESCE( c1, 100/c1 ) AS result
FROM r;
ERR-22012(12122): divisor is equal to zero :
SELECT COALESCE( c1, 100/c1 ) AS result
```



```

*
ERROR at line 1:

```

## Amendment

If the result is TRUE after comparing the conditions, then it returns the corresponding result, and it does not evaluate any more.

It has been changed to execute the type conversion while preparing when the expression corresponding to the result is a constant number. Therefore, the type conversion error due to the constant result expression may not occur.

(Before the amendment, it executed the condition during the execution, and converted the corresponding constant result expression type, then returned it as a result.)

The result type of the following example is number.

'DEFAULT VALUE', default, is a character which can not be converted to a number, so an error occurs while converting it to the number type. This error occurs while preparing.

```

gSQL>
SELECT DECODE( c1, 0, c1, 'DEFAULT VALUE' ) FROM r WHERE c1 = 0;
ERR-22018(12006): data value is not a numeric literal :
SELECT DECODE( c1, 0, c1, 'DEFAULT VALUE' ) FROM r WHERE c1 = 0
*
ERROR at line 1:

```

## Additional Information of Result Type

- If the result type is time, time with time zone, timestamp, timestamp with time zone, interval, then it is set to the information including each result expression.  
(Before the amendment, it was set to the additional information of the first result expression.)
- If the result type is time, time with time zone, timestamp, timestamp with time zone, then the precision is set to the biggest value from each expression.
- If the result type is interval, then, the interval indicator is the combination of each expression's indicator.  
and the precision and the scale is set to the biggest number from each expression.

## Workaround

Describe it by using CASE statement.

```
SELECT CASE2( c1 <> 0, 100/c1, c1 ) AS result
  FROM r;
```

```
==>
```

```
gSQL>
```

```
SELECT CASE WHEN c1 <> 0
            THEN 100/c1
            ELSE c1
            END AS result
  FROM r;
```

```
RESULT
```

```
-----
```

```
0
```

```
1 row selected.
```

```
SELECT DECODE( c1, 0, c1, 100/c1 ) AS result
  FROM r;
```

```
==>
```

```
gSQL>
```

```
SELECT CASE WHEN ( c1 = 0 ) OR ( c1 IS NULL AND 0 IS NULL )
            THEN c1
            ELSE 100/c1
            END AS result
  FROM r;
```

```
RESULT
```

```
-----
```

```
0
```

```
1 row selected.
```

```
SELECT COALESCE( c1, 100/c1 ) AS result
  FROM r;
```

```
==>
```

```
gSQL>
```

```
SELECT CASE WHEN c1 IS NOT NULL
            THEN c1
            ELSE 100/c1
            END AS result
  FROM r;
```

```
RESULT
```

```
-----
```

```
0
```

```
1 row selected.
```

```
SELECT NVL( c1, 100/c1 ) AS result
  FROM r;
```

```

==>
gSQL>
SELECT CASE WHEN c1 IS NOT NULL
           THEN c1
           ELSE 100/c1
           END AS result
FROM r;
RESULT
-----
      0
1 row selected.
SELECT NVL2( c1, c1, 100/c1 ) AS result
FROM r;
==>
gSQL>
SELECT CASE WHEN c1 IS NOT NULL
           THEN c1
           ELSE 100/c1
           END AS result
FROM r;
RESULT
-----
      0
1 row selected.

```

## **ISSUE-4317** It supports SQL\_ATTR\_CONNECTION\_TIMEOUT property.

### Description

If the network is unstable, then the client can not receive the response and stays in blocking status, after sending a query to the server. Therefore, it supports SQL\_ATTR\_CONNECTION\_TIMEOUT property of SQLSetConnectAttr() to solve this problem.

If SQL\_ATTR\_CONNECTION\_TIMEOUT value is set, then the client sends a query to the server and waits for the response as long as the set time. If it can not get the response for the set time, then the client cuts the connection to the server and returns *HYT01 Connection timeout expired* error.

### Symptom

If the network is unstable, then the client waits for the set time after requesting the response to the server.

## Workaround

Alter the kernel property value as follows, so that it can quickly detect whether the connection between the client and the server has an error.

```
net.ipv4.tcp_keepalive_time = 3
net.ipv4.tcp_keepalive_probes = 3
net.ipv4.tcp_keepalive_intvl = 3
net.ipv4.tcp_retries2 = 5
```

## ISSUE-4031 The column name of the table is not properly displayed in .Net Framework.

### Description

When querying the column name in `SQLColAttribute()` and `SQLGetDescField()`, `SQL_DESC_LABEL` property, `SQL_DESC_NAME` property or `SQL_DESC_BASE_COLUMN_NAME` property is used. `SQL_DESC_LABEL` returns the label, when the column has a label. `SQL_DESC_NAME` returns an alias when the column has an alias. And, `SQL_DESC_BASE_COLUMN_NAME` returns the column name.

.Net Framework, data provider for ODBC, uses `SQL_DESC_NAME` when querying the column name, and the column name is unintentionally retrieved when the label is given to the column. Therefore, `DOT_NET_FOR_ODBC`, the connection property, has been added for Net Framework to solve this problem.

### Symptom

If executing the following query in `gsql`, then the column name is retrieved as follows.

```
gSQL> SELECT I1, I1 + I1, I1 AS C1 FROM TEST;
I1 I1 + I1 C1
-- ----- --
1      2  1
```

If executing the query above in .Net Framework, data provider for ODBC, then the query result is as follows.

```
SELECT I1, I1 + I1, I1 AS C1 FROM TEST;
I1 NULL C1
-- ---- --
1    2  1
```

## Workaround

The patch is required.

**ISSUE-4302** When committing the transaction in cluster environment, then the commit server is abnormally terminated.

## Description

If committing the transaction which updated many tables in cluster environment, then the commit server is abnormally terminated and fails to restart.

## Symptom

If committing the transaction in cluster environment, then the table SCN is set for the tables updated by the transaction and they are logged. If a single transaction updates 500 or more tables, then the buffer size used for the logging is insufficient, so the commit server is abnormally terminated. Also, the logging is not properly performed so it fails to restart.

## Workaround

The patch is required.

**ISSUE-4308** When executing the hierarchy query including the sub table which does not specify the view name, then the result is wrong.

## Description

When executing the hierarchy query including the sub table which does not specify the view name, then the result is wrong.

## Symptom

```
--# Normal situation
--# result : 1 row
--#          1,  0
gSQL> SELECT C1, C2
        FROM T1
        START WITH C1 = C1
        CONNECT BY C1 = PRIOR C2;
```

```

C1 C2
-- --
1 0
1 row selected.
--# BUGBUG
--# result : 1 row
--#          1, 0
gSQL> SELECT C1, C2
      FROM ( SELECT C1, C2 FROM T1 )
      START WITH C1 = C1
      CONNECT BY C1 = PRIOR C2;

C1 C2
---- --
null 0
1 row selected.

```

## Workaround

Specify the view name in the sub table.

```

gSQL> SELECT C1, C2
      FROM ( SELECT C1, C2 FROM T1 ) V1
      START WITH C1 = C1
      CONNECT BY C1 = PRIOR C2;

C1 C2
-- --
1 0
1 row selected.

```

**ISSUE-4244** When creating a package and executing it, then *invalid package object status* error occurs.

## Description

If creating a package and executing it, then *invalid package object status* error occurs.

## Symptom

If executing the package for the first time after creating it, then *invalid package object status* error occurs as follows.

```
gSQL> CREATE TABLE r ( r_c1 INTEGER, r_c2 INTEGER );
Table created.
gSQL> INSERT INTO r VALUES ( 1, 1 );
1 row created.
gSQL> COMMIT;
Commit complete.
gSQL> CREATE PACKAGE pkg1 AS
  v1 INTEGER;
  PROCEDURE proc1;
  PROCEDURE proc2;
END;
/
Package created.
gSQL> CREATE PACKAGE BODY pkg1 AS
  PROCEDURE proc1 AS
    x1 INTEGER;
  BEGIN
    INSERT INTO r VALUES ( 1, 1 );
    COMMIT;
    proc2;
    x1 := pkg1.v1;
  END;
  PROCEDURE proc2 AS
  BEGIN
    SELECT r_c1 INTO pkg1.v1
      FROM r
      LIMIT 1;
  END;
END;
/
Package created.
gSQL> COMMIT;
Commit complete.
gSQL> CALL pkg1.proc1;
ERR-2F000(17088): invalid package (PKG1) object status
ERR-2F000(17007): invalid expression :
  x1 := pkg1.v1;
  *
ERROR at line 9:
```

## Workaround

The patch is required.

## **ISSUE-4156** The structure of gloder binary mode has been modified.

### Description

The structure of gloder binary mode has been improved. Accordingly, the binary file structure has been changed, so it is not compatible with the previous version binary file.

### Symptom

N/A

## Workaround

The patch is required.

## **ISSUE-4263** *Split shard* fails after executing *merge shard* on the sharded table.

### Description

Split fails when executing *split shard* after executing *merge shard* on the sharded table because the shard id being used in the table is allocated to the new shard. It happens because an error occurs when acquiring a new shard id while executing *split shard*.

### Symptom

When executing *split shard* after executing *merge shard* on the sharded table, then it fails as follows.

```
gSQL> CREATE TABLE T1
(
  I1 INTEGER,
  I2 INTEGER,
  I3 LONG VARCHAR
)
SHARDING BY RANGE (I1)
SHARD S1 VALUES LESS THAN ( 200 ) AT CLUSTER GROUP G1,
SHARD S2 VALUES LESS THAN ( 400 ) AT CLUSTER GROUP G1,
SHARD S3 VALUES LESS THAN ( 600 ) AT CLUSTER GROUP G2,
```



```
SHARD S4 VALUES LESS THAN ( 800 ) AT CLUSTER GROUP G2,  
SHARD S5 VALUES LESS THAN ( 1000 ) AT CLUSTER GROUP G3,  
SHARD S6 VALUES LESS THAN (MAXVALUE) AT CLUSTER GROUP G3
```

```
;
```

Table created.

```
gSQL> ALTER TABLE T1 MERGE SHARDS S1, S2, S3 INTO S123 AT CLUSTER GROUP G2;
```

Table altered.

```
gSQL> ALTER TABLE T1 SPLIT SHARD S5 INTO ( SHARD S7 VALUES LESS THAN ( 900 ) AT CLUSTER GROUP  
G3 );
```

ERR-23000(15006): "SHARD\_RANGE\_PRIMARY\_KEY": dictionary integrity constraint violation by  
concurrent DDL execution

## Workaround

The patch is required.

## **ISSUE-4247** It supports autocommit option in the precompiler gpec.

### Description

It supports autocommit as gpec option. If autocommit option of gpec is given, then all connections in gc file is executed with AUTO COMMIT ON.

### Symptom

N/A

## Workaround

The patch is required.

## **ISSUE-3825** It supports blob class and clob class in JDBC.

### Description

It supports blob class and clob class in JDBC.

### Symptom

N/A

## Workaround

The patch is required.

### **ISSUE-4261** When creating the specific data file, then a validation error occurs.

#### Description

If setting the data file size to a specific value when creating a tablespace or adding data file, then the session is abnormally terminated. It occurs due to the validation error for a specific data file size.

#### Symptom

If setting the data file size to a specific value when creating a tablespace, then the session is abnormally terminated as follows.

```
gSQL> CREATE TABLESPACE TEST_TBS DATAFILE 'test.dbf' SIZE 314630144;
=====
CALL STACK
=====
...
gsql(main+0x413)[0x558c34]
/lib64/libc.so.6(__libc_start_main+0xf5)[0x7fb3399f9555]
gsql[0x5396f9]
```

## Workaround

Set the data file size to be created to another value.

### **ISSUE-4254** When executing a subquery containing DISTINCT in the cluster system, then a syntax error occurs in the remote server.

#### Description

If configuring a cluster query by using the query and executing it when the subquery containing DISTINCT is described and the subquery target which is not referenced exists in the cluster system, then a syntax error occurs in the remote server.

It is because the number of target expressions in the created cluster query and that of view column names do not match.

## Symptom

```
gSQL> CREATE TABLE t1 ( i1 INTEGER, i2 INTEGER ) SHARDING BY HASH( i1 );
Table created.
gSQL> commit;
Commit complete.
gSQL> SELECT v1.i1 FROM ( SELECT DISTINCT i1, i2 FROM t1) v1;
ERR-42000(16241): MEMBER(G2N1): invalid number of column names specified :
SELECT /*+ NO_MERGE( _A1 ) */ * FROM ( SELECT /*+ USE_DISTINCT_HASH(50) FULL( _A2 ) */
DISTINCT "_A2"."I1", "_A2"."I2" FROM "PUBLIC"."T1"@LOCAL AS "_A2" ) AS "_A1"("I1")

*
ERROR at line 1:
```

## Workaround

Convert DISTINCT statement into GROUP BY statement.

If GROUP BY is not described within the query in which DISTINCT is described, then define all DISTINCT targets by using GROUP BY and omit DISTINCT.

```
gSQL> SELECT v1.i1 FROM ( SELECT i1, i2 FROM t1 GROUP BY i1, i2 ) v1;
no rows selected.
```

## **ISSUE-4246** When using AT clause in EXEC SQL AUTOCOMMIT statement, then an error occurs.

### Description

AT clause is not recognizable in *EXEC SQL AT :db\_name AUTOCOMMIT* statement, so *INVALID HANDLE* error occurs.

### Symptom

An error occurs in the following syntax.

```
EXEC SQL BEGIN DECLARE SECTION;
char          sConnName[10]="con";
EXEC SQL END DECLARE SECTION;
EXEC SQL AT :sConnName AUTOCOMMIT ON;
```

```
[ERROR] SQL ERROR -
SQLCODE : -2
SQLSTATE : HY000
ERROR MSG : Invalid handle
FAILURE
```

## Workaround

The patch is required.

## 21c.1.5 Patch Notes

**ISSUE-4234** When performing PSM DDL after ADD MEMBER, then a dictionary integrity constraint violation occurs for the ROUTINE primary key.

### Description

When performing PSM DDL after ADD MEMBER, then a dictionary integrity constraint violation occurs for the ROUTINE primary key, and this error has been fixed.

### Symptom

When creating a routine and adding a cluster member then creating a routine again, an error occurs as follows.

```
gSQL>
CREATE OR REPLACE FUNCTION u1.func1 ()
RETURN INTEGER
AS
BEGIN
    RETURN 0;
END;
/
Function created.
gSQL>
CREATE OR REPLACE FUNCTION u1.func2 ()
RETURN INTEGER
AS
BEGIN
```

```
        RETURN 0;
END;
/
Function created.
gSQL>
CREATE OR REPLACE FUNCTION u1.func3 ()
RETURN INTEGER
AS
BEGIN
    RETURN 0;
END;
/
Function created.
gSQL>
CREATE OR REPLACE FUNCTION u1.func4 ()
RETURN INTEGER
AS
BEGIN
    RETURN 0;
END;
/
Function created.
```

```
\connect as sysdba
```

```
gSQL> ALTER CLUSTER GROUP G3 ADD CLUSTER MEMBER G3N3 HOST '127.0.0.1' PORT 13350;
```

```
gSQL>
CREATE OR REPLACE FUNCTION u1.func5 ()
RETURN INTEGER
AS
BEGIN
    RETURN 0;
END;
/
ERR-23000(15006): MEMBER(G3N3): "ROUTINES_PRIMARY_KEY": dictionary integrity constraint
violation by concurrent DDL execution
```

## Workaround

The patch is required.

## **ISSUE-4215** If the variable of using clause in EXECUTE IMMEDIATE is IN OUT type, then an error occurs.

### Description

If the variable bind type of using clause in EXECUTE IMMEDIATE is IN OUT type, then an error occurs.

### Symptom

An error occurs as follows.

```

CREATE OR REPLACE PROCEDURE proc_inout( p1 IN OUT INTEGER ) AS
  var1 INTEGER := 0;
BEGIN
  DBMS_OUTPUT.PUT_LINE( 'p1 : ' || p1 );
  var1 := p1;
  p1 := var1 + 10;
END;
/
COMMIT;
DECLARE
  var1 INTEGER;
BEGIN
  var1 := 30;
  EXECUTE IMMEDIATE 'BEGIN proc_inout( ? ); END;' USING IN OUT var1;
  DBMS_OUTPUT.PUT_LINE( 'var1 : ' || var1 );
END;
/
ERR-07006(16098): bind type mismatch of parameter number (1) :
BEGIN proc_inout( ? ); END;
*
ERROR at line 1:
ERR-2F000(17041): execution fail :
  EXECUTE IMMEDIATE 'BEGIN proc_inout( ? ); END;' USING IN OUT var1;
*
ERROR at line 6:

```

### Workaround

The patch is required.

## 21c.1.4 Patch Notes

**ISSUE-4207** When retrieving the records which use rowid, then an error occurs.

### Description

If retrieving the records which use rowid after restarting the system when using the memory tablespace with the data file bigger than 4 GB, then an error occurs. It is because the calculation for the total number of pages is wrong when restarting the system, and this error has been fixed.

### Symptom

If retrieving the records which use rowid after restarting the system as follows, then an error occurs.

```
CREATE TABLESPACE TEST_TBS DATAFILE 'test.dbf' SIZE 5G;
Tablespace created.
CREATE TABLE T1 ( C1 INTEGER, C2 VARCHAR(20) ) TABLESPACE TEST_TBS;
Table created.
INSERT INTO T1 VALUES ( 1, 'aa' );
1 row created.
COMMIT;
Commit complete.
SELECT ROWID, C1,C2 FROM T1;
           ROWID C1 C2
----- -- --
AAAAAAAAAYe9AAGAAAAiAAA 1 aa
1 row selected.
SELECT C1, C2 FROM T1 WHERE ROWID = 'AAAAAAAAAYe9AAGAAAAiAAA';
C1 C2
-- --
1 aa
1 row selected.
// server restart
SELECT C1, C2 FROM T1 WHERE ROWID = 'AAAAAAAAAYe9AAGAAAAiAAA';
ERR-42000(14036): invalid ROWID
```

## Workaround

The patch is required.

## 21c.1.3 Patch Notes

**ISSUE-4189** If creating the procedure whose parameter is consisted in an order of ref cursor, DB type, and executing it, then an error occurs.

### Description

If creating the procedure whose parameter is consisted in an order of ref cursor, DB type, and executing it, then an error occurs.

### Symptom

If a user calls the parameter as follows, then an error occurs.

```
CREATE OR REPLACE PROCEDURE p_test( p1 IN OUT SYS_REFCURSOR,
                                     p2 IN INTEGER ) AS
BEGIN
  IF p2 = 1 THEN
    OPEN p1 FOR SELECT * FROM t1;
  ELSIF p2 = 2 THEN
    OPEN p1 FOR SELECT * FROM t2;
  END IF;
END;
/
Procedure created.
DECLARE
  refcur1 SYS_REFCURSOR;
BEGIN
  p_test( refcur1 , 1 );
END;
/
ERR-2F000(17032): PSM compilation error :
(1) at (4:21): ERR-2F000(17068): wrong number or types of arguments
```



## Workaround

Change the order of defining the parameter when declaring the procedure.

```
CREATE OR REPLACE PROCEDURE p_test( p2 IN INTEGER,
                                   p1 IN OUT SYS_REFCURSOR) AS
BEGIN
  IF p2 = 1 THEN
    OPEN p1 FOR SELECT * FROM t1;
  ELSIF p2 = 2 THEN
    OPEN p1 FOR SELECT * FROM t2;
  END IF;
END;
/
Procedure created.
DECLARE
  refcur1 SYS_REFCURSOR;
BEGIN
  p_test( 1, refcur1 );
END;
/
Anonymous PL block executed.
```

**ISSUE-4188** When *like* operation is convertible to *equal* comparison operation, then the conversion is supported.

### Description

If the pattern of LIKE operation is in literal format without using a wildcard (%) or an underscore (\_), then it supports the conversion to *equal* comparison operation.

### Symptom

LIKE operation which has the same meaning as that of *equal* comparison operation prevents the plan optimization. If LIKE operation is convertible to *equal* comparison operation, then it supports the conversion to *equal* comparison operation.

```
\EXPLAIN PLAN SELECT c_char LIKE 'a' FROM t1;
C_CHAR LIKE 'a'
-----
TRUE
```

```

1 row selected.
>>> start print plan
< Execution Plan >
=====
|  IDX  |  NODE DESCRIPTION                               |  ROWS  |
-----|-----|-----|
|    0  |  SELECT STATEMENT                               |        |
|    1  |    QUERY BLOCK ("SQB_IDX_2")                   |        |
|    2  |      TABLE ACCESS ("T1")                      |        |
=====
      1 - TARGET : T1.C_CHAR = 'a'
      2 - READ COLUMN : T1.C_CHAR
<<< end print plan

```

## Workaround

Convert LIKE operation to *equal* comparison operation.

**ISSUE-4190** If the subquery is unnested by inner join or semi join, then the filter which can be pushed to the left table is pushed down.

## Description

If the subquery is unnested by inner join or semi join, then the right table becomes a subquery and the left table becomes an outer table of the subquery. In this case, the filter which can be pushed to the left table is pushed down.

## Symptom

Before applying the patch,  $r_{c1} = 1$  within the subquery can not be pushed down to the left table  $r$ , but it remains in the join. Then, it is processed by being linked to the hash instant filter after it is selected as hash join.

```

gSQL> \EXPLAIN PLAN
SELECT *
  FROM r
 WHERE EXISTS ( SELECT *
                FROM s
                WHERE r_c1 = s_c1
                   AND r_c1 = 1
                   AND s_c2 = 1

```

```

);
R_C1 R_C2
---- ----
   1   1
1 row selected.
>>> start print plan
< Execution Plan >
=====
|  IDX  |  NODE DESCRIPTION                               |
|-----|-----|
|   0   |  SELECT STATEMENT                               |
|   1   |    QUERY BLOCK ("SQB_IDX_2")                   |
|   2   |      HASH JOIN (SEMI)                          |
|   3   |        TABLE ACCESS ("R")                    |
|   4   |          HASH JOIN INSTANT                     |
|   5   |            TABLE ACCESS ("S")                |
|-----|-----|
1 - TARGET : R.R_C1, R.R_C2
2 - JOINED COLUMN : R.R_C1, R.R_C2
3 - READ COLUMN : R.R_C1, R.R_C2
4 - HASH KEY : S.S_C1
   READ KEY COLUMN : S.S_C1
   HASH FILTER : S.S_C1 = R.R_C1
   LOGICAL FILTER : {R.R_C1} = 1
5 - READ COLUMN : S.S_C1, S.S_C2
   PHYSICAL FILTER : S.S_C2 = 1
<<< end print plan

```

After applying the patch,  $r\_c1 = 1$  is located in left table  $r$  which is related to the corresponding filter.

```

\EXPLAIN PLAN
SELECT *
FROM r
WHERE EXISTS ( SELECT *
               FROM s
               WHERE r_c1 = s_c1
                  AND r_c1 = 1
                  AND s_c2 = 1
             );
R_C1 R_C2
---- ----

```

```

1 1
1 row selected.
>>> start print plan
< Execution Plan >
=====
|  IDX  |  NODE DESCRIPTION  |
-----
0	SELECT STATEMENT
1	QUERY BLOCK ("SQB_IDX_2")
2	HASH JOIN (SEMI)
3	TABLE ACCESS ("R")
4	HASH JOIN INSTANT (UNIQUE)
5	TABLE ACCESS ("S")
=====
1 - TARGET : R.R_C1, R.R_C2
2 - JOINED COLUMN : R.R_C1, R.R_C2
3 - READ COLUMN : R.R_C1, R.R_C2
   PHYSICAL FILTER : R.R_C1 = 1
4 - HASH KEY : S.S_C1
   READ KEY COLUMN : S.S_C1
   HASH FILTER : S.S_C1 = R.R_C1
   FETCH ONE ROW
5 - READ COLUMN : S.S_C1, S.S_C2
   PHYSICAL FILTER : S.S_C2 = 1
<<< end print plan

```

## Workaround

The patch is required.

## 21c.1.2 Patch Notes

**ISSUE-4183** If the actual parameter of the procedure is a bind parameter, then the wrong information is set.

### Description

If the actual parameter of the procedure is a bind parameter, then the wrong information is set and the server is abnormally terminated.

## Symptom

If the actual parameter of the procedure is a bind parameter, then the wrong information is set and the server is abnormally terminated.

```

gSQL> CREATE OR REPLACE PROCEDURE proc1 ( p1 IN VARCHAR2,
   p2 IN VARCHAR2,
   p3 IN VARCHAR2,
   p4 IN VARCHAR2,
   p5 IN NUMBER,
   p6 IN VARCHAR2,
   p7 IN VARCHAR2,
   p8 OUT NUMBER ) AS

    BEGIN
        NULL;
    END;
/
Procedure created.
\var a number
gSQL> BEGIN
    proc1( '20210728', '2' , '068C009581', '01', 0, 'DAILY', 'SYSTEM', :a );
END;
/

```

*The server is abnormally terminated.*

## Workaround

The patch is required.

## **ISSUE-4178** DBMS\_OUTPUT.PUT\_LINE() is output twice.

### Description

When DBMS\_OUTPUT.PUT\_LINE() calls a function including an actual parameter, DBMS\_OUTPUT.PUT\_LINE(), then the contents of the function are output twice.

### Symptom

The function which is an actual parameter is executed twice when executing DBMS\_OUTPUT.PUT\_LINE, so DBMS\_OUTPUT.PUT\_LINE() within the function is also executed twice.

```

DECLARE
  FUNCTION sub( p1 INTEGER ) RETURN INTEGER AS
  BEGIN
    DBMS_OUTPUT.PUT_LINE( 'p1 = ' || p1 );
    RETURN p1;
  END;
BEGIN
  DBMS_OUTPUT.PUT_LINE( 'sub(x) = ' || sub(10) );
END;
/
p1 = 10
p1 = 10
sub(x) = 10
Anonymous PL block executed.

```

## Workaround

The patch is required.

## **ISSUE-4171** When configuring CTE including a bind parameter, then the system is abnormally terminated.

### Description

If CTE is not used in the main query after configuring CTE including a bind parameter, then the system is abnormally terminated.

### Symptom

The information about a bind parameter included in the unused CTE is not configured, so the system is abnormally terminated when referring to the information about the bind parameter.

```

CREATE TABLE t1 ( c1 INTEGER );
VAR v1 VARCHAR(10)
--# fatal
WITH w1 AS ( SELECT * FROM t1 WHERE c1 = :v1 )
, w2 AS ( SELECT * FROM t1 )
SELECT * FROM w2;

```

## Workaround

Do not define CTE which will not be used as follows.

```
CREATE TABLE t1 ( c1 INTEGER );  
VAR v1 VARCHAR(10)  
WITH w2 AS ( SELECT * FROM t1 )  
SELECT * FROM w2;
```

**ISSUE-4174** The performance of when the local caches of the global sequence are run out has been improved.

### Description

The performance was severely downgraded when the local cache of the global sequence were run out, and this problem has been solved.

### Symptom

All servers using sequences proceed the operations to secure local caches from the global cache when the local caches are run out. In this case, they try to competitively secure the remote cserver, so it may downgrade the performance severely.

### Workaround

The patch is required.

**ISSUE-4182** When restarting cyfile, the recovery may not be operated normally.

### Description

If stopping and restarting cyfile while multiple transactions are simultaneously being processed, then the recovery may not be operated normally, and this problem has been solved.

### Symptom

If stopping and restarting cyfile while transactions are being processed in multiple sessions, then it causes a trouble because the previously stored transaction is stored again in the data file.

## Workaround

The patch is required.

## 21c.1.1 Patch Notes

**ISSUE-4157** A syntax error occurs according to the space between *into* and *into parameter* in *select into* statement in PSM.

### Description

A syntax error occurs when two or more spaces exist between *into* and *into parameter* in *select into* statement in PSM.

### Symptom

A syntax error occurs when two or more spaces exist between *into* and *into parameter* in *select into* statement in PSM as follows.

```
gSQL> CREATE OR REPLACE PROCEDURE proc1 AS
      v1 INTEGER;
      BEGIN
        SELECT 0 x
           INTO  v1
          FROM dual;
      END;
      /
ERR-01000(16409): Warning: Routine definition has compilation errors
ERR-2F000(17100): PSM(PROC1) compilation error :
(1) at (4:3): ERR-42000(16062): syntax error
Procedure created.
```

## Workaround

Set the space between *into* and *into parameter* in *select into* statement in PSM into one space.

```
gSQL> CREATE OR REPLACE PROCEDURE proc1 AS
      v1 INTEGER;
      BEGIN
        SELECT 0 x
```



```

        INTO v1
        FROM dual;
END;
/

```

Procedure created.

## **ISSUE-4143** The table referencing error occurs in FROM statement of a query including a hierarchy.

### Description

An error occurs in FROM statement of a query including a hierarchy when referencing the table defined through WITH statement.

### Symptom

If the FROM clause of a query consists of sub tables and the sub tables consist of a query including a hierarchy then an error occurs when referencing Common Table Expression (CTE) defined through WITH statement of a superordinate query within the sub table.

```

gSQL> with
w1 as (
    select * from dual
),
w2 as (
    select 1 from dual
)
SELECT *
FROM
(
    SELECT *
    FROM w1, w2
    CONNECT BY level < 0
)
;
   2   3   4   5   6   7   8   9  10  11  12  13  14  15
ERR-42000(16528): illegal reference of a query name in WITH clause :
        FROM w1, w2
            *
ERROR at line 12:

```

## Workaround

The patch is required.

**ISSUE-4141** An error occurs when specifying *relation\_name.\** in the target clause of a query including a hierarchy.

### Description

An error occurs when specifying *relation\_name.\** in the target clause of a query including a hierarchy.

### Symptom

The expression corresponding to the relation name can not be found when searching for *asterisk(rel.\*)* target which specified the relation in the target clause in a query including a hierarchy.

```
gSQL> SELECT t1.* FROM t1 CONNECT BY LEVEL < 0;
ERR-42000(16036): 'T1': invalid identifier :
SELECT t1.* FROM t1 CONNECT BY LEVEL < 0
      *
ERROR at line 1:
```

## Workaround

The patch is required.

**ISSUE-4139** When the current *with element* references the *with element* which was previously specified in WITH statement, and the referenced *with element* is executed in a materialize method, then it is abnormally terminated.

### Description

When the current *with element* references the *with element* which was previously specified in WITH statement, and the referenced *with element* is executed in a materialize method, then it is abnormally terminated.

## Symptom

w1 can not be found in w2, and it is processed wrong, so it is abnormally terminated.

```
WITH
  w1 AS ( SELECT * FROM dual CONNECT BY level < 0 ),
  w2 AS ( SELECT 1 FROM w1 )
SELECT 1 FROM w2, w2;
```

## Workaround

Use INLINE hint.

```
WITH
  w1 AS ( SELECT /*+ INLINE */ * FROM dual CONNECT BY level < 0 ),
  w2 AS ( SELECT 1 FROM w1 )
SELECT 1 FROM w2, w2;
```



## **Part II.**

---

# **Administration Manual**

|                                                                  |            |
|------------------------------------------------------------------|------------|
| <b>5. Basic Management of GOLDILOCKS Database</b>                | <b>307</b> |
| 5.1 Creating and Configuring GOLDILOCKS Database                 | 308        |
| Creating Database                                                | 308        |
| Specifying Initial Property                                      | 309        |
| Managing Initial Property Using GOLDILOCKS Configuration File    | 309        |
| 5.2 Starting up and Shutting down GOLDILOCKS Instance            | 311        |
| Starting up Instance                                             | 311        |
| Shutting down Instance                                           | 316        |
| 5.3 Managing Process                                             | 318        |
| Master Process                                                   | 318        |
| Listener Process                                                 | 324        |
| 5.4 Managing Memory                                              | 325        |
| GOLDILOCKS Memory Architecture                                   | 325        |
| Managing SSA                                                     | 325        |
| Managing PSA                                                     | 326        |
| 5.5 Monitoring                                                   | 327        |
| Monitoring with Trace File                                       | 327        |
| Monitoring Performance Using View                                | 339        |
| <b>6. Structure and Storage Structure of GOLDILOCKS Database</b> | <b>341</b> |
| 6.1 Managing Control File                                        | 342        |
| Control File Contents                                            | 342        |
| Multiplexing Control File                                        | 344        |
| Restoring Corrupted Control File                                 | 344        |
| Control File Information                                         | 345        |
| 6.2 Managing Redo Log File                                       | 346        |
| Redo Log File Structure                                          | 346        |
| Redo Log Group and Its Member                                    | 347        |
| Restoring Corrupted Redo Log File                                | 348        |
| Redo Log File Information                                        | 349        |
| 6.3 Managing Archive Redo Log File                               | 350        |
| Creating Archive Redo Log File                                   | 350        |
| Maintaining and Dropping Archive Redo Log File                   | 350        |
| Multiplexing Archive Redo Log File Directory                     | 351        |
| 6.4 Managing Tablespace                                          | 352        |
| Tablespace Type                                                  | 352        |
| Managing Tablespace and Data File                                | 352        |
| 6.5 Managing Data File                                           | 358        |
| Data File Matching                                               | 358        |
| Data File Information                                            | 359        |

|           |                                                   |            |
|-----------|---------------------------------------------------|------------|
| 6.6       | Buffer Cache                                      | 360        |
|           | Structure of GOLDILOCKS Buffer Cache              | 360        |
|           | Buffer Cache List                                 | 360        |
|           | Page Frame Status                                 | 361        |
| <b>7.</b> | <b>Backup and Recovery of GOLDILOCKS Database</b> | <b>363</b> |
| 7.1       | ARCHIVELOG Mode                                   | 364        |
|           | ARCHIVELOG Mode                                   | 364        |
|           | NOARCHIVELOG Mode                                 | 364        |
| 7.2       | Backup and Recovery                               | 366        |
|           | Backup                                            | 366        |
|           | Recovery                                          | 371        |
| <b>8.</b> | <b>GOLDILOCKS Database Replication</b>            | <b>387</b> |
| 8.1       | Overview                                          | 388        |
| 8.2       | Operating Method                                  | 389        |
|           | CYCLONE                                           | 389        |
|           | LOGMIRROR                                         | 394        |
|           | CYFILE                                            | 396        |
| 8.3       | Trace Log                                         | 397        |
|           | Troubleshooting of CYCLONE                        | 397        |
|           | Troubleshooting of LOGMIRROR                      | 398        |
|           | Troubleshooting of CYFILE                         | 399        |
| <b>9.</b> | <b>Database Information</b>                       | <b>401</b> |
| 9.1       | DICTIONARY_SCHEMA                                 | 402        |
|           | Views of ALL_family                               | 403        |
|           | Views of DBA_family                               | 469        |
|           | Views of USER_family                              | 528        |
|           | Other Views                                       | 592        |
|           | Aliased Synonym                                   | 607        |
| 9.2       | INFORMATION_SCHEMA                                | 608        |
|           | COLUMNS                                           | 609        |
|           | COLUMN_PRIVILEGES                                 | 612        |
|           | CONSTRAINT_COLUMN_USAGE                           | 613        |
|           | CONSTRAINT_TABLE_USAGE                            | 614        |
|           | INFORMATION_SCHEMA_CATALOG_NAME                   | 615        |
|           | KEY_COLUMN_USAGE                                  | 616        |
|           | MODULES                                           | 617        |
|           | MODULE_BODY                                       | 618        |
|           | MODULE_BODY_MODULE_USAGE                          | 619        |

|                                   |     |
|-----------------------------------|-----|
| MODULE_BODY_ROUTINE_USAGE .....   | 620 |
| MODULE_BODY_SEQUENCE_USAGE .....  | 621 |
| MODULE_BODY_TABLE_USAGE .....     | 622 |
| MODULE_MODULE_USAGE .....         | 623 |
| MODULE_PRIVILEGES .....           | 624 |
| MODULE_ROUTINE_USAGE .....        | 625 |
| MODULE_SEQUENCE_USAGE .....       | 626 |
| MODULE_TABLE_USAGE .....          | 627 |
| PARAMETERS .....                  | 628 |
| REFERENTIAL_CONSTRAINTS .....     | 631 |
| ROUTINES .....                    | 633 |
| ROUTINE_MODULE_USAGE .....        | 637 |
| ROUTINE_PRIVILEGES .....          | 638 |
| ROUTINE_ROUTINE_USAGE .....       | 639 |
| ROUTINE_SEQUENCE_USAGE .....      | 640 |
| ROUTINE_TABLE_USAGE .....         | 641 |
| SCHEMATA .....                    | 642 |
| SEQUENCES .....                   | 643 |
| SQL_FEATURES .....                | 644 |
| SQL_IMPLEMENTATION_INFO .....     | 645 |
| SQL_PACKAGES .....                | 646 |
| SQL_PARTS .....                   | 647 |
| SQL_SIZING .....                  | 648 |
| STATISTICS .....                  | 649 |
| TABLES .....                      | 650 |
| TABLE_CONSTRAINTS .....           | 651 |
| TABLE_PRIVILEGES .....            | 652 |
| USAGE_PRIVILEGES .....            | 653 |
| VIEWS .....                       | 654 |
| VIEW_MODULE_USAGE .....           | 655 |
| VIEW_ROUTINE_USAGE .....          | 656 |
| VIEW_TABLE_USAGE .....            | 657 |
| 9.3 PERFORMANCE_VIEW_SCHEMA ..... | 658 |
| GV\$ Global View .....            | 661 |
| V\$AGABLE_INFO .....              | 663 |
| V\$ARCHIVELOG .....               | 664 |
| V\$AUDITABLE_DB_PRIVILEGES .....  | 665 |
| V\$AUDITABLE_SYSTEM_ACTIONS ..... | 666 |
| V\$BACKUP .....                   | 667 |



|                               |     |
|-------------------------------|-----|
| V\$BALANCER .....             | 668 |
| V\$BCH .....                  | 669 |
| V\$BUFFER_STAT .....          | 670 |
| V\$CLUSTER_DISPATCHER .....   | 671 |
| V\$CLUSTER_LOCATION .....     | 672 |
| V\$CLUSTER_MEMBER .....       | 673 |
| V\$COLUMNS .....              | 674 |
| V\$CONTROLFILE .....          | 675 |
| V\$DATAFILE .....             | 676 |
| V\$DB_CHANGE_TRACKING .....   | 677 |
| V\$DB_FILE .....              | 678 |
| V\$DISPATCHER .....           | 679 |
| V\$ERROR_CODE .....           | 680 |
| V\$GLOBAL_TRANSACTION .....   | 681 |
| V\$INCREMENTAL_BACKUP .....   | 682 |
| V\$INSTANCE .....             | 683 |
| V\$JOURNALING .....           | 684 |
| V\$KEYWORDS .....             | 685 |
| V\$LATCH .....                | 686 |
| V\$LOGFILE .....              | 687 |
| V\$LOCK_WAIT .....            | 688 |
| V\$LOCKED_OBJECT .....        | 689 |
| V\$PLAN_HISTORY .....         | 690 |
| V\$PLAN_HISTORY_LATEST .....  | 691 |
| V\$PROCESS_STAT .....         | 692 |
| V\$PROCESS_MEM_STAT .....     | 693 |
| V\$PROCESS_SQL_STAT .....     | 694 |
| V\$PROPERTY .....             | 695 |
| V\$PSM_RESERVED_WORDS .....   | 696 |
| V\$QUEUE .....                | 697 |
| V\$RESERVED_WORDS .....       | 698 |
| V\$SEQUENCE .....             | 699 |
| V\$SESSION .....              | 700 |
| V\$SESSION_AUDIT .....        | 701 |
| V\$SESSION_CONNECT_INFO ..... | 702 |
| V\$SESSION_EVENT .....        | 703 |
| V\$SESSION_STAT .....         | 704 |
| V\$SESSION_MEM_STAT .....     | 705 |
| V\$SESSION_MEM_USAGE .....    | 706 |

|                                                 |            |
|-------------------------------------------------|------------|
| V\$SESSION_SQL_STAT .....                       | 707        |
| V\$SESSION_WAIT .....                           | 708        |
| V\$SHARED_MODE .....                            | 709        |
| V\$SHARED_SERVER .....                          | 710        |
| V\$SHM_SEGMENT .....                            | 711        |
| V\$SPROPERTY .....                              | 712        |
| V\$SQLFN_METADATA .....                         | 713        |
| V\$SQL_CACHE .....                              | 714        |
| V\$SQL_COMMAND .....                            | 715        |
| V\$SQL_HISTORY .....                            | 716        |
| V\$STATEMENT .....                              | 717        |
| V\$SYSTEM_EVENT .....                           | 718        |
| V\$SYSTEM_STAT .....                            | 719        |
| V\$SYSTEM_MEM_STAT .....                        | 720        |
| V\$SYSTEM_SQL_STAT .....                        | 721        |
| V\$TABLES .....                                 | 722        |
| V\$TABLESPACE .....                             | 723        |
| V\$TABLESPACE_STAT .....                        | 724        |
| V\$TRANSACTION .....                            | 725        |
| V\$WAIT_EVENT_CLASS_NAME .....                  | 726        |
| V\$WAIT_EVENT_NAME .....                        | 727        |
| V\$XA_TRANSACTION .....                         | 728        |
| <b>10. Server Property .....</b>                | <b>729</b> |
| 10.1 Server Property Information .....          | 730        |
| 10.2 AGING_INTERVAL .....                       | 731        |
| Basic Information .....                         | 731        |
| Description .....                               | 731        |
| 10.3 AGING_PLAN_INTERVAL .....                  | 732        |
| Basic Information .....                         | 732        |
| Description .....                               | 732        |
| 10.4 ARCHIVELOG_DIR_1 ~ ARCHIVELOG_DIR_10 ..... | 733        |
| Basic Information .....                         | 733        |
| Description .....                               | 733        |
| 10.5 ARCHIVELOG_FILE .....                      | 734        |
| Basic Information .....                         | 734        |
| Description .....                               | 734        |
| 10.6 ARCHIVELOG_MODE .....                      | 735        |
| Basic Information .....                         | 735        |
| Description .....                               | 735        |

|       |                                  |     |
|-------|----------------------------------|-----|
| 10.7  | BACKUP_DIR_1 ~ BACKUP_DIR_10     | 736 |
|       | Basic Information                | 736 |
|       | Description                      | 736 |
| 10.8  | BLOCK_READ_COUNT                 | 737 |
|       | Basic Information                | 737 |
|       | Description                      | 737 |
| 10.9  | BROADCAST_INDEX_REBUILD_PROTOCOL | 738 |
|       | Basic Information                | 738 |
|       | Description                      | 738 |
| 10.10 | BROADCAST_REBALANCE_PROTOCOL     | 739 |
|       | Basic Information                | 739 |
|       | Description                      | 739 |
| 10.11 | BUFFER_CACHE_SIZE                | 740 |
|       | Basic Information                | 740 |
|       | Description                      | 740 |
| 10.12 | BUFFER_CHECKPOINT_LIST_COUNT     | 741 |
|       | Basic Information                | 741 |
|       | Description                      | 741 |
| 10.13 | BUFFER_FLUSH_THREADS             | 742 |
|       | Basic Information                | 742 |
|       | Description                      | 742 |
| 10.14 | BUFFER_FLUSHING_INTERVAL         | 743 |
|       | Basic Information                | 743 |
|       | Description                      | 743 |
| 10.15 | BUFFER_FREE_LIST_COUNT           | 744 |
|       | Basic Information                | 744 |
|       | Description                      | 744 |
| 10.16 | BUFFER_HASH_BUCKETS              | 745 |
|       | Basic Information                | 745 |
|       | Description                      | 745 |
| 10.17 | BUFFER_HOT_REGION_CRITERIA       | 746 |
|       | Basic Information                | 746 |
|       | Description                      | 746 |
| 10.18 | BUFFER_HOT_REGION_PERCENT        | 747 |
|       | Basic Information                | 747 |
|       | Description                      | 747 |
| 10.19 | BUFFER_LRU_LIST_COUNT            | 748 |
|       | Basic Information                | 748 |
|       | Description                      | 748 |

|       |                                 |     |
|-------|---------------------------------|-----|
| 10.20 | BUFFER_MULTIPAGE_READ_COUNT     | 749 |
|       | Basic Information               | 749 |
|       | Description                     | 749 |
| 10.21 | BUFFER_PREFETCH_PAGE_COUNT      | 750 |
|       | Basic Information               | 750 |
|       | Description                     | 750 |
| 10.22 | BULK_IO_PAGE_COUNT              | 751 |
|       | Basic Information               | 751 |
|       | Description                     | 751 |
| 10.23 | CDISPATCHER_HOT_POLICY_INTERVAL | 752 |
|       | Basic Information               | 752 |
|       | Description                     | 752 |
| 10.24 | CDISPATCHER_LOCKLESS_THREADS    | 753 |
|       | Basic Information               | 753 |
|       | Description                     | 753 |
| 10.25 | CDISPATCHER_SOCKET_BUFFER_SIZE  | 754 |
|       | Basic Information               | 754 |
|       | Description                     | 754 |
| 10.26 | CDISPATCHER_SYNC_THREADS        | 755 |
|       | Basic Information               | 755 |
|       | Description                     | 755 |
| 10.27 | CDISPATCHER_THREADS             | 756 |
|       | Basic Information               | 756 |
|       | Description                     | 756 |
| 10.28 | CHANGE_TRACKING                 | 757 |
|       | Basic Information               | 757 |
|       | Description                     | 757 |
| 10.29 | CHANGE_TRACKING_EXTENT_SIZE     | 758 |
|       | Basic Information               | 758 |
|       | Description                     | 758 |
| 10.30 | CHANGE_TRACKING_FILE            | 759 |
|       | Basic Information               | 759 |
|       | Description                     | 759 |
| 10.31 | CHAR_LENGTH_UNITS               | 760 |
|       | Basic Information               | 760 |
|       | Description                     | 760 |
| 10.32 | CHARACTER_SET                   | 762 |
|       | Basic Information               | 762 |
|       | Description                     | 762 |

|       |                                    |     |
|-------|------------------------------------|-----|
| 10.33 | CHECK_DEDICATE_CONNECTION_INTERVAL | 763 |
|       | Basic Information                  | 763 |
|       | Description                        | 763 |
| 10.34 | CLIENT_MAX_COUNT                   | 764 |
|       | Basic Information                  | 764 |
|       | Description                        | 764 |
| 10.35 | CLIENT_NUMA_POLICY                 | 765 |
|       | Basic Information                  | 765 |
|       | Description                        | 765 |
| 10.36 | CLOSE_PSM_CHILD_STMTS              | 766 |
|       | Basic Information                  | 766 |
|       | Description                        | 766 |
| 10.37 | CLUSTER_ASYNC_COMMIT               | 767 |
|       | Basic Information                  | 767 |
|       | Description                        | 767 |
| 10.38 | CLUSTER_ASYNC_REPLICATION          | 768 |
|       | Basic Information                  | 768 |
|       | Description                        | 768 |
| 10.39 | CLUSTER_CM_BUFFER_COUNT            | 769 |
|       | Basic Information                  | 769 |
|       | Description                        | 769 |
| 10.40 | CLUSTER_CM_BUFFER_SIZE             | 770 |
|       | Basic Information                  | 770 |
|       | Description                        | 770 |
| 10.41 | CLUSTER_CM_READ_BUFFER_SIZE        | 771 |
|       | Basic Information                  | 771 |
|       | Description                        | 771 |
| 10.42 | CLUSTER_COMMIT_SLAVES              | 772 |
|       | Basic Information                  | 772 |
|       | Description                        | 772 |
| 10.43 | CLUSTER_COMMIT_STREAM_ISOLATION    | 773 |
|       | Basic Information                  | 773 |
|       | Description                        | 773 |
| 10.44 | CLUSTER_CONNECTION                 | 774 |
|       | Basic Information                  | 774 |
|       | Description                        | 774 |
| 10.45 | CLUSTER_CONNECTION_TIMEOUT_SEC     | 775 |
|       | Basic Information                  | 775 |
|       | Description                        | 775 |

|       |                                               |     |
|-------|-----------------------------------------------|-----|
| 10.46 | CLUSTER_DATA_SYNC_SERVERS                     | 776 |
|       | Basic Information                             | 776 |
|       | Description                                   | 776 |
| 10.47 | CLUSTER_DEADLOCK_TIMEOUT                      | 777 |
|       | Basic Information                             | 777 |
|       | Description                                   | 777 |
| 10.48 | CLUSTER_DISPATCHER_IN_QUEUE_SIZE              | 778 |
|       | Basic Information                             | 778 |
|       | Description                                   | 778 |
| 10.49 | CLUSTER_DISPATCHER_NUMA_STREAM_MAP            | 779 |
|       | Basic Information                             | 779 |
|       | Description                                   | 779 |
| 10.50 | CLUSTER_DISPATCHER_OUT_QUEUE_SIZE             | 780 |
|       | Basic Information                             | 780 |
|       | Description                                   | 780 |
| 10.51 | CLUSTER_HEARTBEAT_INTERVAL                    | 781 |
|       | Basic Information                             | 781 |
|       | Description                                   | 781 |
| 10.52 | CLUSTER_HEARTBEAT_RETRY_COUNT                 | 782 |
|       | Basic Information                             | 782 |
|       | Description                                   | 782 |
| 10.53 | CLUSTER_IGNORE_INACTIVE_MEMBER                | 783 |
|       | Basic Information                             | 783 |
|       | Description                                   | 783 |
| 10.54 | CLUSTER_MAX_PACKET_SIZE                       | 784 |
|       | Basic Information                             | 784 |
|       | Description                                   | 784 |
| 10.55 | CLUSTER_MAX_PAYLOAD_SIZE                      | 785 |
|       | Basic Information                             | 785 |
|       | Description                                   | 785 |
| 10.56 | CLUSTER_PACKET_ALLOCATION_TIMEOUT             | 786 |
|       | Basic Information                             | 786 |
|       | Description                                   | 786 |
| 10.57 | CLUSTER_PROTOCOL_FAILOVER_POLICY_TIMEOUT      | 787 |
|       | Basic Information                             | 787 |
|       | Description                                   | 787 |
| 10.58 | CLUSTER_PROTOCOL_SESSION_FATAL_POLICY_TIMEOUT | 788 |
|       | Basic Information                             | 788 |
|       | Description                                   | 788 |

|       |                                       |     |
|-------|---------------------------------------|-----|
| 10.59 | CLUSTER_SERVER_RESPONSE_QUEUE_SIZE    | 789 |
|       | Basic Information                     | 789 |
|       | Description                           | 789 |
| 10.60 | CLUSTER_SESSION_HASH_BUCKETS          | 790 |
|       | Basic Information                     | 790 |
|       | Description                           | 790 |
| 10.61 | CLUSTER_SPLIT_BRAIN_RESOLUTION_POLICY | 791 |
|       | Basic Information                     | 791 |
|       | Description                           | 791 |
| 10.62 | CLUSTER_SPLIT_BRAIN_RETRY_COUNT       | 792 |
|       | Basic Information                     | 792 |
|       | Description                           | 792 |
| 10.63 | COMMITTER_HOT_POLICY_INTERVAL         | 793 |
|       | Basic Information                     | 793 |
|       | Description                           | 793 |
| 10.64 | CONTROL_FILE_0 ~ CONTROL_FILE_7       | 794 |
|       | Basic Information                     | 794 |
|       | Description                           | 794 |
| 10.65 | CONTROL_FILE_COUNT                    | 795 |
|       | Basic Information                     | 795 |
|       | Description                           | 795 |
| 10.66 | CONTROL_FILE_TEMP_NAME                | 796 |
|       | Basic Information                     | 796 |
|       | Description                           | 796 |
| 10.67 | COORDINATOR_COMMIT_WRITE_MODE         | 797 |
|       | Basic Information                     | 797 |
|       | Description                           | 797 |
| 10.68 | CSERVERS                              | 798 |
|       | Basic Information                     | 798 |
|       | Description                           | 798 |
| 10.69 | DA_CLIENT_NUMA_NODE                   | 799 |
|       | Basic Information                     | 799 |
|       | Description                           | 799 |
| 10.70 | DATA_STORE_MODE                       | 800 |
|       | Basic Information                     | 800 |
|       | Description                           | 800 |
| 10.71 | DATABASE_ACCESS_MODE                  | 801 |
|       | Basic Information                     | 801 |
|       | Description                           | 801 |

|       |                                         |     |
|-------|-----------------------------------------|-----|
| 10.72 | DATABASE_INSTANCE_NAME                  | 802 |
|       | Basic Information                       | 802 |
|       | Description                             | 802 |
| 10.73 | DDL_AUTOCOMMIT                          | 803 |
|       | Basic Information                       | 803 |
|       | Description                             | 803 |
| 10.74 | DDL_LOCK_TIMEOUT                        | 804 |
|       | Basic Information                       | 804 |
|       | Description                             | 804 |
| 10.75 | DEADLOCK_PRIORITY                       | 805 |
|       | Basic Information                       | 805 |
|       | Description                             | 805 |
| 10.76 | DEFAULT_GLOBAL_SECONDARY_INDEX_CREATION | 806 |
|       | Basic Information                       | 806 |
|       | Description                             | 806 |
| 10.77 | DEFAULT_INDEX_LOGGING                   | 807 |
|       | Basic Information                       | 807 |
|       | Description                             | 807 |
| 10.78 | DEFAULT_INDEX_PCTFREE                   | 808 |
|       | Basic Information                       | 808 |
|       | Description                             | 808 |
| 10.79 | DEFAULT_INITRANS                        | 809 |
|       | Basic Information                       | 809 |
|       | Description                             | 809 |
| 10.80 | DEFAULT_MAXTRANS                        | 810 |
|       | Basic Information                       | 810 |
|       | Description                             | 810 |
| 10.81 | DEFAULT_PCTFREE                         | 811 |
|       | Basic Information                       | 811 |
|       | Description                             | 811 |
| 10.82 | DEFAULT_PCTUSED                         | 812 |
|       | Basic Information                       | 812 |
|       | Description                             | 812 |
| 10.83 | DEFAULT_REMOVAL_BACKUP_FILE             | 813 |
|       | Basic Information                       | 813 |
|       | Description                             | 813 |
| 10.84 | DEFAULT_REMOVAL_OBSOLETE_BACKUP_LIST    | 814 |
|       | Basic Information                       | 814 |
|       | Description                             | 814 |



|       |                                          |     |
|-------|------------------------------------------|-----|
| 10.85 | DEFAULT_SHARDING                         | 815 |
|       | Basic Information                        | 815 |
|       | Description                              | 815 |
| 10.86 | DISABLE_DDL                              | 818 |
|       | Basic Information                        | 818 |
|       | Description                              | 818 |
| 10.87 | DISABLE_DDL_CDC_GIVEUP                   | 822 |
|       | Basic Information                        | 822 |
|       | Description                              | 822 |
| 10.88 | DISABLE_SERIAL_DDL                       | 823 |
|       | Basic Information                        | 823 |
|       | Description                              | 823 |
| 10.89 | DISABLE_UPDATE_PK_CDC_GIVEUP             | 828 |
|       | Basic Information                        | 828 |
|       | Description                              | 828 |
| 10.90 | DISALLOWED_PROTOCOL_TARGETTYPE           | 829 |
|       | Basic Information                        | 829 |
|       | Description                              | 829 |
| 10.91 | DISALLOWED_PROTOCOL_TARGETTYPE_WITH_ALL  | 830 |
|       | Basic Information                        | 830 |
|       | Description                              | 830 |
| 10.92 | DISALLOWED_PROTOCOL_TARGETTYPE_WITH_NAME | 831 |
|       | Basic Information                        | 831 |
|       | Description                              | 831 |
| 10.93 | DISPATCHER_CM_BUFFER_SIZE                | 832 |
|       | Basic Information                        | 832 |
|       | Description                              | 832 |
| 10.94 | DISPATCHER_CM_UNIT_SIZE                  | 833 |
|       | Basic Information                        | 833 |
|       | Description                              | 833 |
| 10.95 | DISPATCHER_CONNECTIONS                   | 834 |
|       | Basic Information                        | 834 |
|       | Description                              | 834 |
| 10.96 | DISPATCHER_HOT_POLICY_INTERVAL           | 835 |
|       | Basic Information                        | 835 |
|       | Description                              | 835 |
| 10.97 | DISPATCHER_LOAD_BALANCING                | 836 |
|       | Basic Information                        | 836 |
|       | Description                              | 836 |

|        |                                                |     |
|--------|------------------------------------------------|-----|
| 10.98  | DISPATCHER_NUMA_STREAM_MAP                     | 837 |
|        | Basic Information                              | 837 |
|        | Description                                    | 837 |
| 10.99  | DISPATCHER_QUEUE_SIZE                          | 838 |
|        | Basic Information                              | 838 |
|        | Description                                    | 838 |
| 10.100 | DISPATCHER_REQUEST_MINI_QUEUE_COUNT            | 839 |
|        | Basic Information                              | 839 |
|        | Description                                    | 839 |
| 10.101 | DISPATCHER_RESPONSE_MINI_QUEUE_COUNT           | 840 |
|        | Basic Information                              | 840 |
|        | Description                                    | 840 |
| 10.102 | DISPATCHERS                                    | 841 |
|        | Basic Information                              | 841 |
|        | Description                                    | 841 |
| 10.103 | EXECUTE_INST_HASH_TABLE_USING_AVAILABLE_MEMORY | 842 |
|        | Basic Information                              | 842 |
|        | Description                                    | 842 |
| 10.104 | FETCH_FAILOVER                                 | 843 |
|        | Basic Information                              | 843 |
|        | Description                                    | 843 |
| 10.105 | GLOBAL_CONNECTION_ALLOW_SESSION_DEPENDENCY     | 844 |
|        | Basic Information                              | 844 |
|        | Description                                    | 844 |
| 10.106 | GLOBAL_JOURNAL_BUFFER_SIZE                     | 845 |
|        | Basic Information                              | 845 |
|        | Description                                    | 845 |
| 10.107 | GLOBAL_JOURNAL_BUFFER_TOTAL_MAX_SIZE           | 846 |
|        | Basic Information                              | 846 |
|        | Description                                    | 846 |
| 10.108 | GLOBAL_PROPERTY_LOCK_TIMEOUT                   | 847 |
|        | Basic Information                              | 847 |
|        | Description                                    | 847 |
| 10.109 | GLOBAL_TRANSACTION_COMMIT_WRITE_MODE           | 848 |
|        | Basic Information                              | 848 |
|        | Description                                    | 848 |
| 10.110 | GLOBAL_TRANSACTION_ISOLATION_SCOPE             | 849 |
|        | Basic Information                              | 849 |
|        | Description                                    | 849 |

|        |                                     |     |
|--------|-------------------------------------|-----|
| 10.111 | GLOBAL_TRANSACTION_LOG_DIR          | 850 |
|        | Basic Information                   | 850 |
|        | Description                         | 850 |
| 10.112 | GLOBAL_TRANSACTION_LOG_FILE_SIZE    | 851 |
|        | Basic Information                   | 851 |
|        | Description                         | 851 |
| 10.113 | GMASTER_NUMA_NODE                   | 852 |
|        | Basic Information                   | 852 |
|        | Description                         | 852 |
| 10.114 | GMON_AUTOSTART                      | 853 |
|        | Basic Information                   | 853 |
|        | Description                         | 853 |
| 10.115 | HINT_ERROR                          | 854 |
|        | Basic Information                   | 854 |
|        | Description                         | 854 |
| 10.116 | IDLE_TIMEOUT                        | 855 |
|        | Basic Information                   | 855 |
|        | Description                         | 855 |
| 10.117 | IN_DOUBT_DECISION                   | 856 |
|        | Basic Information                   | 856 |
|        | Description                         | 856 |
| 10.118 | IN_KEY_RANGE_ARRAY_COUNT            | 857 |
|        | Basic Information                   | 857 |
|        | Description                         | 857 |
| 10.119 | INCREMENTAL_BACKUP_SCAN_BUFFER_SIZE | 858 |
|        | Basic Information                   | 858 |
|        | Description                         | 858 |
| 10.120 | INDEX_BUILD_PARALLEL_FACTOR         | 859 |
|        | Basic Information                   | 859 |
|        | Description                         | 859 |
| 10.121 | INDEX_LOGGING_THROTTLING            | 860 |
|        | Basic Information                   | 860 |
|        | Description                         | 860 |
| 10.122 | INDEX_REBUILD_BLOCK_READ_COUNT      | 861 |
|        | Basic Information                   | 861 |
|        | Description                         | 861 |
| 10.123 | INDEX_TREE_MERGE_PARALLEL_FACTOR    | 862 |
|        | Basic Information                   | 862 |
|        | Description                         | 862 |

|        |                                  |     |
|--------|----------------------------------|-----|
| 10.124 | INST_ALLOCATOR_COUNT             | 863 |
|        | Basic Information                | 863 |
|        | Description                      | 863 |
| 10.125 | INST_HASH_TABLE_BUCKET_MAX_COUNT | 864 |
|        | Basic Information                | 864 |
|        | Description                      | 864 |
| 10.126 | INST_TABLE_BLOCK_SIZE            | 865 |
|        | Basic Information                | 865 |
|        | Description                      | 865 |
| 10.127 | IPC_CHANNEL_COUNT                | 866 |
|        | Basic Information                | 866 |
|        | Description                      | 866 |
| 10.128 | JOURNAL_TEMP_DIR                 | 867 |
|        | Basic Information                | 867 |
|        | Description                      | 867 |
| 10.129 | KEEPALIVE_IDLE_TIME              | 868 |
|        | Basic Information                | 868 |
|        | Description                      | 868 |
| 10.130 | LOCAL_CLUSTER_MEMBER             | 869 |
|        | Basic Information                | 869 |
|        | Description                      | 869 |
| 10.131 | LOCAL_CLUSTER_MEMBER_HOST        | 870 |
|        | Basic Information                | 870 |
|        | Description                      | 870 |
| 10.132 | LOCAL_CLUSTER_MEMBER_PORT        | 871 |
|        | Basic Information                | 871 |
|        | Description                      | 871 |
| 10.133 | LOCAL_JOURNAL_BUFFER_SIZE        | 872 |
|        | Basic Information                | 872 |
|        | Description                      | 872 |
| 10.134 | LOCATION_FILE                    | 873 |
|        | Basic Information                | 873 |
|        | Description                      | 873 |
| 10.135 | LOCATOR_QUERY_TIMEOUT            | 874 |
|        | Basic Information                | 874 |
|        | Description                      | 874 |
| 10.136 | LOCK_HASH_TABLE_SIZE             | 875 |
|        | Basic Information                | 875 |
|        | Description                      | 875 |

|        |                                      |     |
|--------|--------------------------------------|-----|
| 10.137 | LOCKLESS_CSERVICES                   | 876 |
|        | Basic Information                    | 876 |
|        | Description                          | 876 |
| 10.138 | LOG_BLOCK_SIZE                       | 877 |
|        | Basic Information                    | 877 |
|        | Description                          | 877 |
| 10.139 | LOG_BUFFER_SIZE                      | 878 |
|        | Basic Information                    | 878 |
|        | Description                          | 878 |
| 10.140 | LOG_DIR                              | 879 |
|        | Basic Information                    | 879 |
|        | Description                          | 879 |
| 10.141 | LOG_FILE_SIZE                        | 880 |
|        | Basic Information                    | 880 |
|        | Description                          | 880 |
| 10.142 | LOG_GROUP_COUNT                      | 881 |
|        | Basic Information                    | 881 |
|        | Description                          | 881 |
| 10.143 | LOG_MIRROR_MODE                      | 882 |
|        | Basic Information                    | 882 |
|        | Description                          | 882 |
| 10.144 | LOG_MIRROR_SHARED_MEMORY_STATIC_SIZE | 883 |
|        | Basic Information                    | 883 |
|        | Description                          | 883 |
| 10.145 | LOG_MIRROR_TIMEOUT                   | 884 |
|        | Basic Information                    | 884 |
|        | Description                          | 884 |
| 10.146 | LOG_SYNC_INTERVAL                    | 885 |
|        | Basic Information                    | 885 |
|        | Description                          | 885 |
| 10.147 | LOG_SYNC_INTERVAL_MSEC               | 886 |
|        | Basic Information                    | 886 |
|        | Description                          | 886 |
| 10.148 | MAX_GROUP_COUNT                      | 887 |
|        | Basic Information                    | 887 |
|        | Description                          | 887 |
| 10.149 | MAX_JOURNAL_FILE_SIZE                | 888 |
|        | Basic Information                    | 888 |
|        | Description                          | 888 |

|        |                                            |     |
|--------|--------------------------------------------|-----|
| 10.150 | MAX_NODE_COUNT                             | 889 |
|        | Basic Information                          | 889 |
|        | Description                                | 889 |
| 10.151 | MAXIMUM_CONCURRENT_ACTIVITIES              | 890 |
|        | Basic Information                          | 890 |
|        | Description                                | 890 |
| 10.152 | MAXIMUM_FILE_CACHE_SIZE                    | 891 |
|        | Basic Information                          | 891 |
|        | Description                                | 891 |
| 10.153 | MAXIMUM_FLANGE_COUNT                       | 892 |
|        | Basic Information                          | 892 |
|        | Description                                | 892 |
| 10.154 | MAXIMUM_FLUSH_BUFFER_PAGE_COUNT            | 893 |
|        | Basic Information                          | 893 |
|        | Description                                | 893 |
| 10.155 | MAXIMUM_FLUSH_LOG_BLOCK_COUNT              | 894 |
|        | Basic Information                          | 894 |
|        | Description                                | 894 |
| 10.156 | MAXIMUM_FLUSH_PAGE_COUNT                   | 895 |
|        | Basic Information                          | 895 |
|        | Description                                | 895 |
| 10.157 | MAXIMUM_INDEX_REBUILD_JOURNAL_REPLAY_COUNT | 896 |
|        | Basic Information                          | 896 |
|        | Description                                | 896 |
| 10.158 | MAXIMUM_JOURNAL_REPLAY_COUNT               | 897 |
|        | Basic Information                          | 897 |
|        | Description                                | 897 |
| 10.159 | MAXIMUM_NAMED_CURSOR_COUNT                 | 898 |
|        | Basic Information                          | 898 |
|        | Description                                | 898 |
| 10.160 | MAXIMUM_PACKAGE_INSTANCE_COUNT             | 900 |
|        | Basic Information                          | 900 |
|        | Description                                | 900 |
| 10.161 | MAXIMUM_SESSION_CM_BUFFER_SIZE             | 901 |
|        | Basic Information                          | 901 |
|        | Description                                | 901 |
| 10.162 | MEASURE_CLUSTER_LATENCY                    | 902 |
|        | Basic Information                          | 902 |
|        | Description                                | 902 |

|        |                                     |     |
|--------|-------------------------------------|-----|
| 10.163 | MEMORY_MERGE_RUN_COUNT              | 903 |
|        | Basic Information                   | 903 |
|        | Description                         | 903 |
| 10.164 | MEMORY_SORT_RUN_SIZE                | 904 |
|        | Basic Information                   | 904 |
|        | Description                         | 904 |
| 10.165 | MIN_SAMPLE_ROW_COUNT                | 905 |
|        | Basic Information                   | 905 |
|        | Description                         | 905 |
| 10.166 | MINIMUM_UNDO_PAGE_COUNT             | 906 |
|        | Basic Information                   | 906 |
|        | Description                         | 906 |
| 10.167 | NET_BUFFER_SIZE                     | 907 |
|        | Basic Information                   | 907 |
|        | Description                         | 907 |
| 10.168 | NLS_DATE_FORMAT                     | 908 |
|        | Basic Information                   | 908 |
|        | Description                         | 908 |
| 10.169 | NLS_TIME_FORMAT                     | 909 |
|        | Basic Information                   | 909 |
|        | Description                         | 909 |
| 10.170 | NLS_TIME_WITH_TIME_ZONE_FORMAT      | 910 |
|        | Basic Information                   | 910 |
|        | Description                         | 910 |
| 10.171 | NLS_TIMESTAMP_FORMAT                | 911 |
|        | Basic Information                   | 911 |
|        | Description                         | 911 |
| 10.172 | NLS_TIMESTAMP_WITH_TIME_ZONE_FORMAT | 912 |
|        | Basic Information                   | 912 |
|        | Description                         | 912 |
| 10.173 | NUMA                                | 913 |
|        | Basic Information                   | 913 |
|        | Description                         | 913 |
| 10.174 | NUMA_MAP                            | 914 |
|        | Basic Information                   | 914 |
|        | Description                         | 914 |
| 10.175 | OFFLINE_MEMBER_AFTER_FAILOVER       | 915 |
|        | Basic Information                   | 915 |
|        | Description                         | 915 |

|        |                                               |     |
|--------|-----------------------------------------------|-----|
| 10.176 | ONLINE_INDEX_REBUILD_JOURNAL_REPLAY_THRESHOLD | 916 |
|        | Basic Information                             | 916 |
|        | Description                                   | 916 |
| 10.177 | ONLINE_JOURNAL_REPLAY_THRESHOLD               | 917 |
|        | Basic Information                             | 917 |
|        | Description                                   | 917 |
| 10.178 | OS_GROUP_ACCESS                               | 918 |
|        | Basic Information                             | 918 |
|        | Description                                   | 918 |
| 10.179 | PACKET_COMPRESSION_THRESHOLD                  | 919 |
|        | Basic Information                             | 919 |
|        | Description                                   | 919 |
| 10.180 | PAGE_CHECKSUM_TYPE                            | 920 |
|        | Basic Information                             | 920 |
|        | Description                                   | 920 |
| 10.181 | PARALLEL_IO_FACTOR                            | 921 |
|        | Basic Information                             | 921 |
|        | Description                                   | 921 |
| 10.182 | PARALLEL_IO_GROUP_1 ~ PARALLEL_IO_GROUP_16    | 922 |
|        | Basic Information                             | 922 |
|        | Description                                   | 922 |
| 10.183 | PARALLEL_LOAD_FACTOR                          | 923 |
|        | Basic Information                             | 923 |
|        | Description                                   | 923 |
| 10.184 | PENDING_LOG_BUFFER_COUNT                      | 924 |
|        | Basic Information                             | 924 |
|        | Description                                   | 924 |
| 10.185 | PLAN_CACHE                                    | 925 |
|        | Basic Information                             | 925 |
|        | Description                                   | 925 |
| 10.186 | PLAN_CACHE_SIZE                               | 926 |
|        | Basic Information                             | 926 |
|        | Description                                   | 926 |
| 10.187 | PLAN_HISTORY                                  | 927 |
|        | Basic Information                             | 927 |
|        | Description                                   | 927 |
| 10.188 | PLAN_HISTORY_SIZE                             | 928 |
|        | Basic Information                             | 928 |
|        | Description                                   | 928 |



|        |                                      |     |
|--------|--------------------------------------|-----|
| 10.189 | PRIVATE_STATIC_AREA_INIT_SIZE        | 929 |
|        | Basic Information                    | 929 |
|        | Description                          | 929 |
| 10.190 | PRIVATE_STATIC_AREA_NEXT_SIZE        | 930 |
|        | Basic Information                    | 930 |
|        | Description                          | 930 |
| 10.191 | PRIVATE_STATIC_AREA_SHRINK_THRESHOLD | 931 |
|        | Basic Information                    | 931 |
|        | Description                          | 931 |
| 10.192 | PRIVATE_STATIC_AREA_SIZE             | 932 |
|        | Basic Information                    | 932 |
|        | Description                          | 932 |
| 10.193 | PROCESS_MAX_COUNT                    | 933 |
|        | Basic Information                    | 933 |
|        | Description                          | 933 |
| 10.194 | QUERY_TIMEOUT                        | 934 |
|        | Basic Information                    | 934 |
|        | Description                          | 934 |
| 10.195 | READABLE_ARCHIVELOG_DIR_COUNT        | 935 |
|        | Basic Information                    | 935 |
|        | Description                          | 935 |
| 10.196 | READABLE_BACKUP_DIR_COUNT            | 936 |
|        | Basic Information                    | 936 |
|        | Description                          | 936 |
| 10.197 | REBALANCE_BLOCK_READ_COUNT           | 937 |
|        | Basic Information                    | 937 |
|        | Description                          | 937 |
| 10.198 | RECOMPILE_CHECK_MINIMUM_PAGE_COUNT   | 938 |
|        | Basic Information                    | 938 |
|        | Description                          | 938 |
| 10.199 | RECOMPILE_PAGE_PERCENT               | 939 |
|        | Basic Information                    | 939 |
|        | Description                          | 939 |
| 10.200 | RECOVERY_LOG_BUFFER_SIZE             | 940 |
|        | Basic Information                    | 940 |
|        | Description                          | 940 |
| 10.201 | RECYCLEBIN                           | 941 |
|        | Basic Information                    | 941 |
|        | Description                          | 941 |

|        |                                 |     |
|--------|---------------------------------|-----|
| 10.202 | REDO_LOG_COMPRESSION_THRESHOLD  | 942 |
|        | Basic Information               | 942 |
|        | Description                     | 942 |
| 10.203 | REFINE_RELATION                 | 943 |
|        | Basic Information               | 943 |
|        | Description                     | 943 |
| 10.204 | SESSION_FATAL_BEHAVIOR          | 944 |
|        | Basic Information               | 944 |
|        | Description                     | 944 |
| 10.205 | SESSION_MEMORY_INIT_SIZE        | 945 |
|        | Basic Information               | 945 |
|        | Description                     | 945 |
| 10.206 | SESSION_MEMORY_SHRINK_THRESHOLD | 946 |
|        | Basic Information               | 946 |
|        | Description                     | 946 |
| 10.207 | SHARED_MEMORY_ADDRESS           | 947 |
|        | Basic Information               | 947 |
|        | Description                     | 947 |
| 10.208 | SHARED_MEMORY_STATIC_KEY        | 948 |
|        | Basic Information               | 948 |
|        | Description                     | 948 |
| 10.209 | SHARED_MEMORY_STATIC_NAME       | 949 |
|        | Basic Information               | 949 |
|        | Description                     | 949 |
| 10.210 | SHARED_MEMORY_STATIC_SIZE       | 950 |
|        | Basic Information               | 950 |
|        | Description                     | 950 |
| 10.211 | SHARED_REQUEST_QUEUE_COUNT      | 951 |
|        | Basic Information               | 951 |
|        | Description                     | 951 |
| 10.212 | SHARED_SERVERS                  | 952 |
|        | Basic Information               | 952 |
|        | Description                     | 952 |
| 10.213 | SHARED_SESSION                  | 953 |
|        | Basic Information               | 953 |
|        | Description                     | 953 |
| 10.214 | SNAPSHOT_STATEMENT_TIMEOUT      | 954 |
|        | Basic Information               | 954 |
|        | Description                     | 954 |

|        |                                    |     |
|--------|------------------------------------|-----|
| 10.215 | SQL_HISTORY_SIZE                   | 955 |
|        | Basic Information                  | 955 |
|        | Description                        | 955 |
| 10.216 | SQL_HISTORY_TYPE                   | 956 |
|        | Basic Information                  | 956 |
|        | Description                        | 956 |
| 10.217 | SUPPLEMENTAL_LOG_DATA_PRIMARY_KEY  | 957 |
|        | Basic Information                  | 957 |
|        | Description                        | 957 |
| 10.218 | SYSTEM_DISK_DATA_TABLESPACE_SIZE   | 958 |
|        | Basic Information                  | 958 |
|        | Description                        | 958 |
| 10.219 | SYSTEM_FILE_IO                     | 959 |
|        | Basic Information                  | 959 |
|        | Description                        | 959 |
| 10.220 | SYSTEM_LOGGER_DIR                  | 960 |
|        | Basic Information                  | 960 |
|        | Description                        | 960 |
| 10.221 | SYSTEM_MEMORY_AUX_TABLESPACE_SIZE  | 961 |
|        | Basic Information                  | 961 |
|        | Description                        | 961 |
| 10.222 | SYSTEM_MEMORY_DATA_TABLESPACE_SIZE | 962 |
|        | Basic Information                  | 962 |
|        | Description                        | 962 |
| 10.223 | SYSTEM_MEMORY_DICT_TABLESPACE_SIZE | 963 |
|        | Basic Information                  | 963 |
|        | Description                        | 963 |
| 10.224 | SYSTEM_MEMORY_TEMP_TABLESPACE_SIZE | 964 |
|        | Basic Information                  | 964 |
|        | Description                        | 964 |
| 10.225 | SYSTEM_MEMORY_UNDO_TABLESPACE_SIZE | 965 |
|        | Basic Information                  | 965 |
|        | Description                        | 965 |
| 10.226 | SYSTEM_TABLESPACE_DIR              | 966 |
|        | Basic Information                  | 966 |
|        | Description                        | 966 |
| 10.227 | SYSTEM_UDS_DIR                     | 967 |
|        | Basic Information                  | 967 |
|        | Description                        | 967 |

|        |                         |     |
|--------|-------------------------|-----|
| 10.228 | TCP_CLIENT_NUMA_NODE    | 968 |
|        | Basic Information       | 968 |
|        | Description             | 968 |
| 10.229 | TCP_NODELAY             | 969 |
|        | Basic Information       | 969 |
|        | Description             | 969 |
| 10.230 | TEMP_SEGMENT_CACHE_SIZE | 970 |
|        | Basic Information       | 970 |
|        | Description             | 970 |
| 10.231 | TEMP_UNDO_ENABLED       | 971 |
|        | Basic Information       | 971 |
|        | Description             | 971 |
| 10.232 | TIMED_STATISTICS        | 972 |
|        | Basic Information       | 972 |
|        | Description             | 972 |
| 10.233 | TIMER_INTERVAL          | 973 |
|        | Basic Information       | 973 |
|        | Description             | 973 |
| 10.234 | TIMEZONE                | 974 |
|        | Basic Information       | 974 |
|        | Description             | 974 |
| 10.235 | TRACE_ALTER_SYSTEM      | 975 |
|        | Basic Information       | 975 |
|        | Description             | 975 |
| 10.236 | TRACE_DDL               | 976 |
|        | Basic Information       | 976 |
|        | Description             | 976 |
| 10.237 | TRACE_LOG_ID            | 977 |
|        | Basic Information       | 977 |
|        | Description             | 977 |
| 10.238 | TRACE_LOG_MSGBUF_SIZE   | 978 |
|        | Basic Information       | 978 |
|        | Description             | 978 |
| 10.239 | TRACE_LOG_TIME_DETAIL   | 979 |
|        | Basic Information       | 979 |
|        | Description             | 979 |
| 10.240 | TRACE_LOGGER            | 980 |
|        | Basic Information       | 980 |
|        | Description             | 980 |

|        |                                     |     |
|--------|-------------------------------------|-----|
| 10.241 | TRACE_LOGGER_REMOTE_HOST            | 981 |
|        | Basic Information                   | 981 |
|        | Description                         | 981 |
| 10.242 | TRACE_LOGGER_REMOTE_PORT            | 982 |
|        | Basic Information                   | 982 |
|        | Description                         | 982 |
| 10.243 | TRACE_LOGIN                         | 983 |
|        | Basic Information                   | 983 |
|        | Description                         | 983 |
| 10.244 | TRACE_LONG_RUN_CURSOR               | 984 |
|        | Basic Information                   | 984 |
|        | Description                         | 984 |
| 10.245 | TRACE_LONG_RUN_SQL                  | 986 |
|        | Basic Information                   | 986 |
|        | Description                         | 986 |
| 10.246 | TRACE_LONG_RUN_TIMER                | 988 |
|        | Basic Information                   | 988 |
|        | Description                         | 988 |
| 10.247 | TRACE_XA                            | 989 |
|        | Basic Information                   | 989 |
|        | Description                         | 989 |
| 10.248 | TRANSACTION_ALLOCATION_TIMEOUT      | 990 |
|        | Basic Information                   | 990 |
|        | Description                         | 990 |
| 10.249 | TRANSACTION_COMMIT_WRITE_MODE       | 991 |
|        | Basic Information                   | 991 |
|        | Description                         | 991 |
| 10.250 | TRANSACTION_MAXIMUM_UNDO_PAGE_COUNT | 992 |
|        | Basic Information                   | 992 |
|        | Description                         | 992 |
| 10.251 | TRANSACTION_TABLE_SIZE              | 993 |
|        | Basic Information                   | 993 |
|        | Description                         | 993 |
| 10.252 | TRANSACTION_TIMEOUT                 | 995 |
|        | Basic Information                   | 995 |
|        | Description                         | 995 |
| 10.253 | UNDO_RELATION_ALLOCATION_TIMEOUT    | 996 |
|        | Basic Information                   | 996 |
|        | Description                         | 996 |

|        |                                    |       |
|--------|------------------------------------|-------|
| 10.254 | UNDO_RELATION_COUNT                | 997   |
|        | Basic Information                  | 997   |
|        | Description                        | 997   |
| 10.255 | UNDO_SHRINK_THRESHOLD              | 999   |
|        | Basic Information                  | 999   |
|        | Description                        | 999   |
| 10.256 | USE_LARGE_PAGES                    | 1,000 |
|        | Basic Information                  | 1,000 |
|        | Description                        | 1,000 |
| 10.257 | USER_DATA_TABLESPACE_MEDIA_TYPE    | 1,001 |
|        | Basic Information                  | 1,001 |
|        | Description                        | 1,001 |
| 10.258 | USER_DATA_TABLESPACE_SIZE          | 1,002 |
|        | Basic Information                  | 1,002 |
|        | Description                        | 1,002 |
| 10.259 | USER_DISK_DATA_TABLESPACE_NEXTSIZE | 1,003 |
|        | Basic Information                  | 1,003 |
|        | Description                        | 1,003 |
| 10.260 | USER_TEMP_TABLESPACE_SIZE          | 1,004 |
|        | Basic Information                  | 1,004 |
|        | Description                        | 1,004 |
| 10.261 | XA_TRANSACTION_IDLE_TIMEOUT        | 1,005 |
|        | Basic Information                  | 1,005 |
|        | Description                        | 1,005 |

**5.**

---

## **Basic Management of GOLDILOCKS Database**

# 5.1 Creating and Configuring GOLDILOCKS Database

## Creating Database

Create database using `gcreatedb` which is included in GOLDILOCKS package. Before creating database, the followings should be considered.

**Table 5-1** Considerations when creating database

| Considerations                                                                                                                                                                                                                                                                                                                                      | For more information, refer to                                                                                                                                                                           |
|-----------------------------------------------------------------------------------------------------------------------------------------------------------------------------------------------------------------------------------------------------------------------------------------------------------------------------------------------------|----------------------------------------------------------------------------------------------------------------------------------------------------------------------------------------------------------|
| Consider the space size of tables and indexes to be used in database.                                                                                                                                                                                                                                                                               | <ul style="list-style-type: none"> <li>• <b>Structure and Storage Structure of GOLDILOCKS Database</b></li> </ul>                                                                                        |
| Consider the location to create database files. It is because the database performance will be improved by properly distributing the files and dispersing the disk IO. For example, a user can allocate redo log file to a separate disk or stripe it, and then disperse data file into a number of disks, to execute a parallel disk IO operation. | <ul style="list-style-type: none"> <li>• <b>Managing Redo Log File</b></li> </ul>                                                                                                                        |
| Be aware of each property's concepts and its operation which are set in server property file, then constantly manage them.                                                                                                                                                                                                                          | <ul style="list-style-type: none"> <li>• <b>Specifying Initial Property</b></li> <li>• <b>Managing Initial Property Using GOLDILOCKS Configuration File</b></li> <li>• <b>Server Property</b></li> </ul> |

In addition to the above considerations, refer to **Creating Database** in **Getting Started** for more options to be considered when creating database.

A user should set environment variables to use GOLDILOCKS, and the variables are `$GOLDILOCKS_HOME` and `$GOLDILOCKS_DATA`. The property file, `goldilock.properties.conf`, for creating and managing GOLDILOCKS database is in `$GOLDILOCKS_DATA/conf`.

- `GOLDILOCKS_HOME`: Binaries which are included in GOLDILOCKS package are installed here, and it can be overwritten during software version upgrading (The license backup is required.)
- `GOLDILOCKS_DATA`: Log file, data file, control file which are used by GOLDILOCKS database are installed here, and it can not be overwritten.



## Specifying Initial Property

A user can use properties to control the information for operation and management in GOLDILOCKS.

### Initial Property

Set the properties of when creating or starting the database as follows.

1. Setting system environment variable
  - I. Change it by typing in the command window in which GOLDILOCKS is installed and database is created or operated.
  - II. It is necessary to add the prefix before the property name, and the prefix is *GOLDILOCKS\_*.
  - The following is an example of changing SHARED\_MEMORY\_STATIC\_SIZE to 100M.

```
export GOLDILOCKS_SHARED_MEMORY_STATIC_SIZE=100M
```

2. Property file: The prefix is not required, so change it directly in the property file.

- The following is an example of changing SHARED\_MEMORY\_STATIC\_SIZE to 200M.
- Shared memory static size (100 M ~ 32 G)

```
SHARED_MEMORY_STATIC_SIZE = 200M
```



If the same property is set to system environment variable and property file, then the value of the property file will be applied. For example, if SHARED\_MEMORY\_STATIC\_SIZE is set to 100 M as the system environment variable, and SHARED\_MEMORY\_STATIC\_SIZE is set to 200 M as the property file, then SHARED\_MEMORY\_STATIC\_SIZE will be applied to 200 M when operating database.

## Managing Initial Property Using GOLDILOCKS Configuration File

Property file is in *\$GOLDILOCKS\_DATA/conf*, and is divided into two according to the file format.

- Text property file
  - File name: goldilocks.properties.conf
  - It is "property name = value" format file, and a user can directly edit it.

- If a binary property file exists, it does not read text property file.
- Binary property file
  - It is created by the system, and a user can not edit it directly.
  - File name: goldilocks.properties.binary
  - Use gdump tool to retrieve the binary file's contents.



If a text property file and a binary property file exist together, it reads the binary property file only. The text property file is not processed. This binary property file is managed by user SQL (`ALTER SYSTEM SET`), and can be edited using SQL only.

For information, refer to `ALTER SYSTEM SET property_name`, `ALTER SYSTEM RESET property_name`.

- Editing text property file
  - Use "PROPERTY\_NAME = VALUE" format.
  - Use '#' for annotation.
  - Property has one of the following three data types.
    - Character data type: Use a single quote (') to set the character value. Use `<GOLDILOCKS_DATA TA>` if the character value includes `$GOLDILOCKS_DATA` link.
    - Numeric data type: Do not use calculation for numeric data. For example, `LOG_BUFFER_SIZE = 1024 * 1024` is not allowed to use. Its size is selectable accordingly such as K (kilobyte), M (megabyte), G (gigabyte), T (terabyte), and P (petabyte)
    - Boolean data type: Allowed to use ON/OFF, ENABLE/DISABLE, 1/0 and TRUE/FALSE, YES/NO.

## 5.2 Starting up and Shutting down GOLDILOCKS Instance

This chapter describes starting up and shutting down of GOLDILOCKS instance.

### Starting up Instance

GOLDILOCKS instance can be started only by a user with SYSDBA privilege.

GOLDILOCKS instance can be started by using Direct Attach (D/A) method and dedicated method of Client/Server (C/S). However, it can not be started by using shared method of C/S.

### Multi-level Startup

GOLDILOCKS has multi-level startup procedure. Multi-level startup procedure enables to change the data base's state by the intervention of administrator in each phase.

The phases are idle, nomount, mount, open, and each phase has the following features.

#### Idle Phase

The idle phase is a state in which an instance is not started up.

If connecting to gsql when an instance is not started, then it will be connected to idle instance as follows. In this phase, any sever command can not be executed except for \startup.

```
% gsql sys gliese --as sysdba
Connected to an idle instance.
gSQL> select * from dual;
ERR-08003(40044): connection does not exist
gSQL>
```

- Administrator operations in idle phase
  - Adjusting the property required to start up the instance
  - Transition to nomount using \startup in gsql
- Operation in an instance at the nomount transition
  - Starting up gmaster which is a daemon managing GOLDILOCKS instance
  - Starting up timer thread and cleanup thread in gmaster
  - Allocating and initializing Shared memory Static Area (SSA).

**Table 5-2** Applied properties at the transition to nomount

| Property name             | Description                                             |
|---------------------------|---------------------------------------------------------|
| CLIENT_MAX_COUNT          | Maximum number of connectable sessions                  |
| CONTROL_FILE_0 ~ 7        | Path of control file                                    |
| CONTROL_FILE_COUNT        | The number of valid path among the path of control file |
| DATA_STORE_MODE           | Store mode of GOLDILOCKS instance                       |
| PLAN_CACHE_SIZE           | Maximum size of shared memory for plan cache            |
| PROCESS_MAX_COUNT         | Maximum number of connectable process                   |
| SHARED_MEMORY_ADDRESS     | Address of shared memory                                |
| SHARED_MEMORY_STATIC_NAME | Name of shared memory                                   |
| SHARED_MEMORY_STATIC_KEY  | Key value for creating shared memory                    |
| SHARED_MEMORY_STATIC_SIZE | Size of shared memory to be created                     |
| SYSTEM_LOGGER_DIR         | Path of system logger                                   |

Properties can not be changed in idle phase. An administrator changes the properties as follows.

To use an environment variable, then set `GOLDILOCKS_[property_name]` to a desired value and transit it to nomount. Then, the properties will be applied.

```
% export GOLDILOCKS_CLIENT_MAX_COUNT=1000
```

To use 'SCOPE = FILE', record the property value to be changed in the file. The recorded property will be applied at nomount transition.

```
gSQL> alter system set client_max_count = 1000 scope = file;
System altered.
gSQL> \shutdown
Shutdown success
gSQL> \startup
Startup success
gSQL>
```

## Nomount Phase

The nomount phase is a state in which it is not mounted to database, and only the gmaster process has been started. A gmaster is a daemon which manages GOLDILOCKS instance.

The following describes how to transit idle phase to nomount phase.

```
% gsql sys gliese --as sysdba
Connected to an idle instance.
gSQL> \startup nomount
Startup success
```

gSQL>

- Administrator operations in nomount phase
  - Adjusting nomount property
  - For more information, refer to **ALTER SYSTEM {MOUNT | OPEN} DATABASE, ALTER DATABASE RESTORE**.
- Operation in an instance at the mount transition
  - Loading the control file to database
  - Preparing for database recovery
  - Starting up threads in gmaster such as checkpoint, log flusher, page flusher, IO slave, archive log

**Table 5-3** Updatable properties in nomount phase

| Property name            | Description                                                          |
|--------------------------|----------------------------------------------------------------------|
| DATABASE_ACCESS_MODE     | Database access mode (READ ONLY, READ WRITE)                         |
| LOG_BUFFER_SIZE          | Redo log buffer size                                                 |
| PARALLEL_LOAD_FACTOR     | The number of threads for parallel operations after loading database |
| PARALLEL_IO_FACTOR       | The number of parallel threads for loading database                  |
| PARALLEL_IO_GROUP_1 ~ 16 | Datafile group at parallel loading                                   |
| PENDING_LOG_BUFFER_COUNT | The number of delayed log buffers                                    |
| TRANSACTION_TABLE_SIZE   | Transaction table size                                               |
| UNDO_RELATION_COUNT      | The number of undo relations                                         |

## Mount Phase

The mount phase is a state in which it is mounted to database, and the database recognizes the control file. All sections in the control file is controllable in this phase.

The following describes how to transit nomount phase to mount phase.

```
% gsql sys gliese --as sysdba
Connected to an idle instance.
gSQL> \startup nomount
Startup success
gSQL> alter system mount database;
System altered.
gSQL>
```

- Administrator operations in mount phase
  - Adjusting mount properties
  - **ALTER SYSTEM {MOUNT | OPEN} DATABASE**
  - **ALTER DATABASE ADD LOGFILE**
  - **ALTER DATABASE DROP LOGFILE**

- ALTER DATABASE RENAME LOGFILE
  - ALTER DATABASE { ARCHIVELOG | NOARCHIVELOG }
  - ALTER DATABASE DELETE BACKUP
  - ALTER DATABASE REGISTER
  - ALTER DATABASE RECOVER
  - ALTER DATABASE RESTORE
  - ALTER SESSION SET property\_name
  - ALTER SYSTEM RESET property\_name
  - ALTER SYSTEM SWITCH LOGFILE
  - ALTER SYSTEM [KILL | DISCONNECT] SESSION
  - ALTER TABLESPACE name ADD [DATAFILE|MEMORY]
  - ALTER TABLESPACE name RENAME DATAFILE
  - ALTER TABLESPACE name [ONLINE|OFFLINE]
- Operation in an instance at the open transition
    - Loading all data file used in an instance to shared memory
    - Performing instance recovery
    - Creating NOLOGGING index
    - Deleting objects or files which are not deleted by ager thread
    - Creating cache for dictionary objects
    - If "SHARED\_SESSION" property is set to YES, process monitor thread in gmaster will be started up.
    - Process monitor thread executes balancer process, dispatcher process, shared-server process.

**Table 5-4** Updatable property in mount

| Property name                        | Description                                                   |
|--------------------------------------|---------------------------------------------------------------|
| ARCHIVELOG_FILE                      | Prefix name of archive file                                   |
| IN_DOUBT_DECISION                    | Decision about in-doubt transaction                           |
| LOCK_HASH_TABLE_SIZE                 | Hash table size of lock administrator                         |
| LOG_MIRROR_MODE                      | Log mirroring mode                                            |
| LOG_MIRROR_SHARED_MEMORY_STATIC_SIZE | Shared memory size for log mirroring                          |
| SUPPLEMENTAL_LOG_DATA_PRIMARY_KEY    | Whether to perform supplemental logging at the database-level |

## Open Phase

The open phase is a state in which all the data file is loaded to memory, and it is ready for service. All operations are allowed in this phase.

```
% gsql sys gliese --as sysdba
Connected to an idle instance.
gSQL> \startup mount
```

```
Startup success
gSQL> alter system open database;
System altered.
gSQL>
```

The database access mode is selectable at the transition to open phase. The database access modes are divided into READ\_ONLY mode and READ\_WRITE mode. The READ\_ONLY mode can only read data in database, but READ\_WRITE mode can both read and write the data.

To open database in READ\_ONLY mode, the previous database should be normally shut down. If the access mode is omitted, it refers to the DATABASE\_ACCESS\_MODE property value when opening database.

```
gSQL> \shutdown abort
Shutdown success
gSQL> \startup mount
Startup success
gSQL> alter system open database read only;
ERR-42000(14038): unable to recover database in READ ONLY mode
gSQL> alter system open database read write;
System altered.
...
gSQL> \shutdown normal
Shutdown success
gSQL> \startup mount
Startup success
gSQL> alter system open database read only;
System altered.
```

## Diagnosis

It is possible to execute several phases at a same time using a single command(\startup) when starting up instance. If a certain phase fails, the administrator should figure out in which phase the failure occurs. Check using to which phase the instance has come using V\$INSTANCE. Then the administrator can continue operations of startup instance from the subsequent phase.

The following is an example of starting up instance to open phase after \startup failure.

```
% gsql sys gliese --as sysdba
Connected to an idle instance.
gSQL> \startup
ERR-42000(14051): media recovery required - 'TEST_TBS'
gSQL> select INSTANCE_STATUS from v$instance;
```

```

INSTANCE_STATUS
-----
MOUNTED
1 row selected.
...
gSQL> alter system open database;
System altered.

```

## Shutting down Instance

GOLDILOCKS instance can be terminated only by a user with SYSDBA privilege. It is not allowed to create new session during shutdown.

GOLDILOCKS instance can be shut down by Direct Attach (D/A) method and dedicated method of Client/Server (C/S), but it can not be shut down by shared method of C/S.

There are four types of instance shutdown mode, and they are shutdown normal, shutdown transactional, shutdown immediate and shutdown abort.

### Shutdown Normal

The shutdown normal is set by default if a particular mode is not specified when shutting down. Use this type if a user wants to shut down an instance normally.

```

gSQL> \shutdown normal
Shutdown success
gSQL>

```

The followings describe the characteristics of shutdown normal.

- New session is not allowed.
- New transactions and statements are allowed in session which already have been connected.
- Waiting for all the sessions which are connected to the instance to be shut down.
- It does not execute instance recovery process when starting up the instance.

### Shutdown Transactional

Use this type to shut down the currently proceeding transactions normally even when the session is forcibly shut down.



```
gSQL> \shutdown transactional
Shutdown success
gSQL>
```

The followings describe the characteristics of shutdown transactional.

- Neither new session nor is new transaction allowed.
- New statements are allowed in ongoing transaction.
- Waiting for the ongoing transactions to be shut down.
- The session will be automatically terminated after the ongoing transactions is terminated.
- It does not execute instance recovery process when starting up the instance.

## Shutdown Immediate

Use this type to terminate the instance when a user can not terminate current transactions.

```
gSQL> \shutdown immediate
Shutdown success
gSQL>
```

The followings describe the characteristics of shutdown immediate.

- Neither new session nor is new transaction allowed.
- Forcibly shut down ongoing sessions and transactions.
- Waiting until the background thread of the system to be completed.
- It does not execute instance recovery process when starting up the instance.

## Shutdown Abort

Use this type when a user judged the instance is in an abnormal state.

```
gSQL> \shutdown abort
Shutdown success
gSQL>
```

The followings describe the characteristics of shutdown abort.

- Neither new session nor is new transaction allowed.
- Forcibly shut down ongoing sessions and transactions.
- Instantly shut down the background thread of the system.
- It executes instance recovery process when starting up the instance.

## 5.3 Managing Process

This chapter describes the background processes of GOLDILOCKS instance.

### Master Process

Master process performs the asynchronous operation for database performance and monitoring. It consists of many threads.

The master process' executable file name is gmaster.

### Checkpoint Thread

Checkpoint thread executes asynchronous checkpoint events which occur in the log flushing thread. The checkpoint event occurs whenever redo log file is switched.

Checkpoint event is executed asynchronously regardless of a user, and its log is recorded in system.trc as follows.

```
[2014-09-11 14:04:34.704465 THREAD(14497,140178383427328)] [INFORMATION]
[CHECKPOINT] begin
...
[2014-09-11 14:04:34.743933 THREAD(14497,140178383427328)] [INFORMATION]
[CHECKPOINT] save control file
[2014-09-11 14:04:34.759521 THREAD(14497,140178383427328)] [INFORMATION]
[CHECKPOINT] end
```

### Log Flushing Thread

User transactions record redo log in log buffer, and it is periodically recorded in log file by log flushing thread.

Log switching occurs when redo log is recorded to the end of the log file, then it will be recorded in the next redo log file. When the log switching occurs, checkpoint event is transferred to a checkpoint thread.

If reusable log file does not exist when the log file is switched, all queries except for the read-only queries will wait until the reusable log file is created.

The message remains as follows in system.trc when logging is blocked.

```
...
[2014-09-11 14:31:44.315871 THREAD(19102,139674683647744)] [INFORMATION]
[LOG FLUSHER] disable logging - blocked lfsn(1)
...
```

## Log Archiving Thread

The log archiving thread asynchronously archives redo log file. This thread is executed only when database is operated in ARCHIVELOG mode.

Log archiving is a part of checkpoint process, and it is executed by log archiving event in which the checkpoint thread occurred.

The message remains as follows in system.trc when redo\_0\_0.log is archived to archive\_0.log.

```
[2014-09-11 14:13:32.515996 THREAD(16913,140631135463168)] [INFORMATION]
[ARCHIVELOG BEGIN] LOG(/home/test/work/product/Gliese/home/wal/redo_0_0.log(0)) =>
ARCHIVE(/home/test/work/product/Gliese/home/archive_log/archive_0.log)
[2014-09-11 14:13:33.145850 THREAD(16913,140631135463168)] [INFORMATION]
[ARCHIVELOG END] (/home/test/work/product/Gliese/home/archive_log/archive_0.log) : SUCCESS
...
```

## Ager Thread

Ager thread physically drops the logically dropped database objects.

DROP TABLE statement executes only logical drop operation to maintain statement level consistency in GLOBALLOCKS. Therefore, the statement which was invoked before DROP TABLE can explore the records of dropped table even when DROP TABLE is executed.

The message remains as follows in system.trc when table and tablespaces are physically dropped.

```
[2014-09-11 14:13:37.966788 THREAD(16925,139892990408448)] [INFORMATION]
[AGER] aging table - object scn(4561), object view scn(4562), type(0), physical
id(25043954302976)
...
[2014-09-11 14:13:37.966917 THREAD(16925,139892990408448)] [INFORMATION]
[AGER] aging tablespace - object scn(4561), object view scn(4564), tablespace id(61)
```

## Timer Thread

Timer thread asynchronously sets time to the system to reduce the time measuring cost of user transactions, and the user transactions read the time set in the system.

The time precision is set according to **TIMER\_INTERVAL**, and the default value is 10 ms.

The followings describe the case of using the time set in the timer thread. The time error occurs as much as **TIMER\_INTERVAL** value. For example, if **TIMER\_INTERVAL** is 10 ms, then the time error is also 10 ms.

- Time out: **QUERY\_TIMEOUT**, **IDLE\_TIMEOUT**, **DDL\_LOCK\_TIMEOUT**, ...
- Message record time written in trace log
- Startup time of login statement or transaction
- Time recorded in transaction commit redo log

## Page Flusher & IO Slave Threads

It applies the updated data pages to the disk when a checkpoint occurs. The updated information is stored in multiple data files in a tablespace. For that, the page flusher thread distributes operations to IO slave threads per each tablespace and data files and manages them. Then the IO slave threads record the updated pages in the data file in parallel.

If tables and index pages stored in the disk tablespace are updated by caching them to the buffer, they are linked to the checkpoint list, and the pages updated for the reuse in the buffer cache are linked to the buffer replace list. I/O slave threads reflect the pages in IO checkpoint list and the pages in the buffer replace list on the disk at the checkpoint or regularly.

Storing the updated pages as many as possible at a time improves performance. The number of written pages at each time follow the properties in **MAXIMUM\_FLUSH\_PAGE\_COUNT**.

After the updated pages are written to the data file, the message remains in `system.trc` is as follows.

```
[2014-09-11 14:13:38.329162 THREAD(16925,139893221086976)] [INFORMATION]
[IO SLAVE] flush datafile ( tablespace : 0, datafile : 0 )
[2014-09-11 14:13:38.552161 THREAD(16925,139893221086976)] [INFORMATION]
[IO SLAVE] flush datafile ( tablespace : 1, datafile : 0 )
[2014-09-11 14:13:38.587510 THREAD(16925,139893221086976)] [INFORMATION]
[IO SLAVE] flush datafile ( tablespace : 2, datafile : 0 )
[2014-09-11 14:13:38.587831 THREAD(16925,139893221086976)] [INFORMATION]
[IO SLAVE] flush datafile ( tablespace : 62, datafile : 0 )
[2014-09-11 14:13:38.620239 THREAD(16925,139893221086976)] [INFORMATION]
[IO SLAVE] flush datafile ( tablespace : 63, datafile : 0 )
```

## Cleanup Thread

Cleanup thread cleans up the system resource asynchronously, and performs the following operations.

- It cleans up normally terminated session. GOLDILOCKS processes termination of a user session logically, and uses cleanup thread for physical termination of a session.
- It cleans up abnormally terminated session. If the session is using transactions, then they will be rolled back.
- It checks the time-out of snapshot statements. If a session exceeds the time-out, it is forced to be terminated.

When cleaning up the abnormally terminated session, a message remains in system.trc as follows.

```
[2014-09-12 10:34:38.387349 THREAD(23003,140722556352256)] [WARNING]
[CLEANUP] cleaning session - env(19), session(20), transaction(FFFFFFFFFFFFFFF),
program(gsql), pid(23209), thread(140080441665280)
[2014-09-12 10:34:38.387515 THREAD(23003,140722556352256)] [WARNING]
[CLEANUP] cleaning up 1 sessions
```

If a snapshot statement exceeds the time-out, a message remains in system.trc as follows.

```
[2014-09-12 10:49:21.842179 THREAD(3972,139706316711680)] [WARNING]
[CLEANUP] long statement timeout - pid(8029), thread(140053960505088), program(gsql),
statement start time(2014-09-12 10:48:49.963471)
```

If abnormally terminated session is terminated by 'kill-9' signal during changing shared memory when exclusive latch is acquired, it is no longer possible to operate the database. In this situation, a message remains in system.trc as follows, and the instance should be terminated using *SHUTDOWN ABORT*.

```
[2014-09-12 11:12:58.809249 THREAD(15313,140671386121984)] [WARNING]
[CLEANUP] failed to cleaning session - server restart required
..... dead session in critical section - env(3), session(4), transaction(47001E0004),
pid(15296), thread(140178075756288)
```

## Process Monitor Thread

The process monitor thread executes processes, and monitors them.

- It is executed only when "SHARED\_SESSION" property is set to *YES*.
- It executes load-balancer (gbalancer), dispatcher(gdispatcher), shared-server(gserver), and re-executes them when they are abnormally terminated.
- It does not monitor listener (glsnr) process.

## Cluster Recover Thread

When starting up a node on a cluster system environment, if the node phases up to the mount phase, then the cluster recover thread is created. If there is an in-doubt transaction, the cluster recover thread communicates with the cluster recover thread on the remote node, and recovers the in-doubt transaction.

If there is an in-doubt transaction, the cluster recover thread communicates with the cluster recover thread on the remote node, and figures out the status of the in-doubt transaction. If the remote node is restarted and it is not recovered yet, then it transfers a message requesting the preferential completion of recovery and recovers the in-doubt transaction status after the recovery is completed.

The in-doubt transaction statuses figured out through the remote node are NONE, PREPARE, COMMIT, and ROLLBACK. If the cluster recover thread received the response such as COMMIT, ROLLBACK from at least one remote node, then it performs COMMIT or ROLLBACK. If the cluster recover thread received the response such as NONE, PREPARE from all remote nodes, then it performs ROLLBACK because COMMIT or ROLLBACK never has been performed on any cluster node.

The in-doubt transaction recovery using the cluster recover thread leaves the following messages in system.trc.

```
[2018-11-22 16:52:00.466805 INSTANCE(G3N2) THREAD(7828,140557371479808)] [WARNING]
[CLUSTER RECOVER] begin recovery
[2018-11-22 16:52:00.467221 INSTANCE(G3N2) THREAD(7828,140557371479808)] [WARNING]
[CLUSTER RECOVER] commit in-doubt transaction - commit scn(999.0.439), global transaction
id(1.29294650), local transaction id(4)
[2018-11-22 16:52:00.468253 INSTANCE(G3N2) THREAD(7828,140557371479808)] [WARNING]
[CLUSTER RECOVER] rollback in-doubt transaction - commit scn(1000.439), global transaction
id(4.34406459), local transaction id(59)
[2018-11-22 16:52:00.469198 INSTANCE(G3N2) THREAD(7828,140557371479808)] [WARNING]
[CLUSTER RECOVER] commit in-doubt transaction - commit scn(1001.0.439), global transaction
id(5.35127356), local transaction id(60)
```

## Failover Thread

When starting up a node on a cluster system environment, if the node phases up to the LOCAL OPEN phase, then the cluster failover thread is created. Cluster failover thread performs the failover for the error node by reselecting a coordinator or offlining when an error occurs on a specific node or the network in the cluster system.

In a situation requiring the failover, a normal node which acquired a failover lock among other normal nodes communicates with failover threads of other nodes, then performs the failover.

The failover performed by the failover thread leaves the following messages in system.trc.

```

[2018-11-22 15:27:34.619208 INSTANCE(G1N1) THREAD(20140,140219957368576)] [INFORMATION]
[FAILOVER] begin - failover member(5)
[2018-11-22 15:27:34.619418 INSTANCE(G1N1) THREAD(20140,140219957368576)] [INFORMATION]
[FAILOVER] acquire failover lock - driver(0), target(5), driver seq(1)
[2018-11-22 15:27:34.619692 INSTANCE(G1N1) THREAD(20183,140317097449216)] [INFORMATION]
[CDISPATCHER-S2] disconnect member - target member(5)
[2018-11-22 15:27:34.619893 INSTANCE(G1N1) THREAD(20183,140317097449216)] [INFORMATION]
[CDISPATCHER-S2] finalize sender socket - member(5)
[2018-11-22 15:27:34.621860 INSTANCE(G1N1) THREAD(20140,140219957368576)] [INFORMATION]
[FAILOVER] acquire failover lock
...
[2018-11-22 15:27:38.726436 INSTANCE(G1N1) THREAD(20140,140219957368576)]
[INFORMATION][FAILOVER] member(5) has failedover
[2018-11-22 15:27:38.728624 INSTANCE(G1N1) THREAD(20140,140219957368576)] [INFORMATION]
[FAILOVER] release failover lock - driver(-1), target(5), driver seq(1)
[2018-11-22 15:27:38.728786 INSTANCE(G1N1) THREAD(20140,140219957368576)] [WARNING]
reset remote session map - member(5)
[2018-11-22 15:27:38.729679 INSTANCE(G1N1) THREAD(20140,140219957368576)] [INFORMATION]
[FAILOVER] finished

```

## Buffer Checkpoint Flusher, Buffer Replace Flusher

The table and index pages stored in disk table spaces are cached in a buffer and linked to a checkpoint list as changes are made. The buffer checkpoint flusher reflects pages linked to the checkpoint list to the corresponding data file. The buffer checkpoint flusher is performed when a checkpoint event occurs, or is periodically performed after sleeping for the period set in the **BUFFER\_FLUSHING\_INTERVAL** property. The number of buffer checkpoint flushers is determined by **BUFFER\_CHECKPOINT\_LIST\_COUNT** property.

If the requested page does not exist in the buffer cache, then it fills the buffer cache by reading pages from the data file. When looking for the available space in the buffer caches, then it links the updated pages which are not currently used to the buffer replace list. Then, the buffer replace flusher reflects the pages linked to the buffer replace list to the corresponding data file. The buffer replace flusher wakes up by the event when an available space does not exist because the buffer is full, or is periodically performed after sleeping for the period set in the **BUFFER\_FLUSHING\_INTERVAL** property. The number of buffer replace flushers is determined by **BUFFER\_FLUSH\_THREADS** property.

## Listener Process

Listener process enables remote access through the network in a client/server environment. Listener process waits for a client connection using **LISTEN\_PORT**. If connected in dedicated mode, new gserver starts, and connects a client. If connected in shared mode, it selects underloaded dispatcher (gdispatcher) using load-balancer (gbalancer), and connects a client.

gserver is a kind of operation server, and it executes a client request.

If LISTEN\_PORT is already in use, the following error occurs.

```
% glsnr --start  
ERR-HY000(11077): given address is already in use
```

Listener process operates independently from the instance. In other words, listener process can start up and shut down regardless of instance start up anytime.



## 5.4 Managing Memory

### GOLDILOCKS Memory Architecture

GOLDILOCKS uses SSA which is a memory shared by all sessions in the system, a shared memory for data base pages, and PSA (heap memory) which each session uses independently.

Figure 1 Shared memory

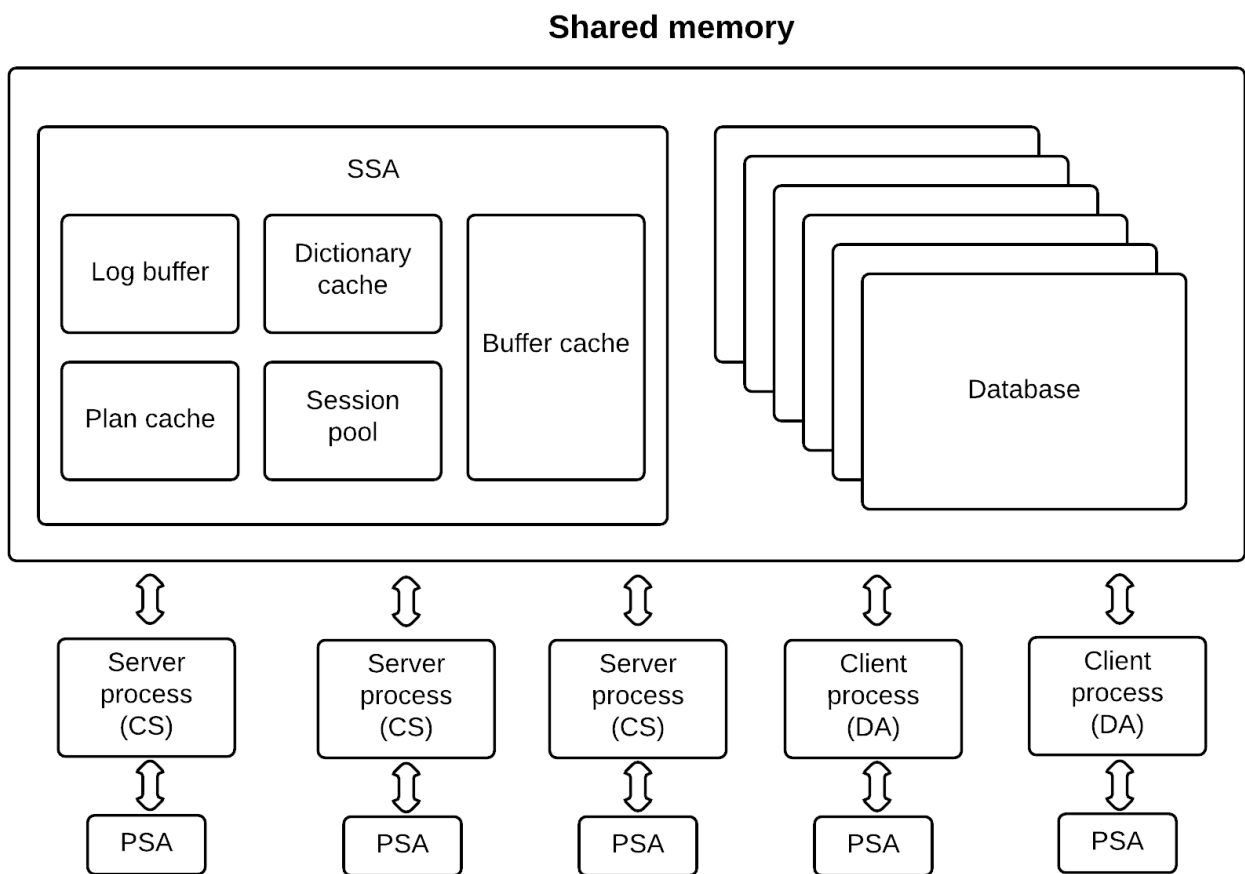

### Managing SSA

Shared Static Area (SSA) is a memory area to store information which is shared by the system's all sessions.

A new process should use the same physical address for using SSA. It is because the position of all information referenced by SSA uses the physical address.

The physical starting address of SSA is determined by **SHARED\_MEMORY\_STATIC\_KEY** and **SESSION\_FATAL\_BEHAVIOR**. The following error occurs when another program is already using shared memory key assigned by the same **SHARED\_MEMORY\_STATIC\_KEY**, and the memory assigned by **SHARED\_MEMORY\_ADDRESS**.

```
% gsql sys gliese --as sysdba
Connected to an idle instance.
gSQL> \startup
ERR-HY000(11029): shared memory segment exists
gSQL>
```

SSA stores main information, and they are log buffer, dictionary cache, plan cache, session pool, lock pool, and transaction pool.

SSA size is determined by **SHARED\_MEMORY\_STATIC\_SIZE**. The system automatically manages memories used in session/lock/transaction pool and dictionary cache, and a user can not arbitrarily manage them. However, a user can arbitrarily manage the usage of log buffer and plan cache.

If the default value of log buffer and plan cache are increased, **SHARED\_MEMORY\_STATIC\_SIZE** should be increased accordingly. Otherwise, the following error occurs.

```
% gsql sys gliese --as sysdba
Connected to an idle instance.
gSQL> \startup
ERR-HY000(13010): Insufficient static area
gSQL>
```

## Managing PSA

Private Static Area (PSA) is a heap memory area, and it is used independently by each session. **PRIVATE\_STATIC\_AREA\_SIZE** determines the maximum size of PSA.

An initial size is allocated to PSA when a session is created. If additional memory is required in the session, PSA can be allocated up to its maximum size. The following error occurs when it exceeds the maximum size.

```
ERR-HY000(13011): Unable to extend memory: [MAX: 104857600, TOTAL: 102764408, ALLOC: 2097240]
DESC: private static area
```

## 5.5 Monitoring

Database monitoring is needed not only to detect and prevent the problem which can be an issue in the future, but also to find a way to improve database management. For monitoring, GOLDILOCKS database provides text file type trace log and several performance views.

### Monitoring with Trace File

From when the instance starts up until it terminates, GOLDILOCKS database provides the system log which records the overall system error, warning, information. In addition, it provides XA transaction log, trace log such as DDL log, and SQL Trace Log. For more information, refer to **SQL Trace Log**.

### Managing Trace Log File

GOLDILOCKS database's trace log file consists of system.trc file and xa.trc file. The system.trc file records system log and DDL log, and xa.trc file records XA transaction log. Trace log file is created in directory set in SYSTEM\_LOGGER\_DIR property. Therefore, it is generally created in trc directory below the directory specified in GOLDILOCKS\_DATA environment variable. The trace log file's size is 10 Mbytes. If its space is insufficient, the existing trace log file with unique file extension is preserved, and the new trace log file is created.

Listener trace log file is created as *listener.trc* in trc directory below the directory specified by GOLDILOCKS\_DATA environment variable. The log file size is 10 Mbytes. If the space is insufficient, the existing log file with unique file extension is preserved, and the new trace log file is created.

Except for system log, XA transaction log and DDL log can ON/OFF the monitoring. Set the TRACE\_DDL property value to 0 to turn off the DDL log, or set it to 1 to turn on the DDL log. XA log is set in the same way using the TRACE\_XA property.

### System Log

The errors, warnings, and information which occurred in database instance from when master process starts up until it terminates are recorded in the system log.

### System Log Format

System log is recorded in the following format.

```
['log record data and time' THREAD('process Id', 'thread handle')] ['log level']
['log prefix'] 'log body'
```

- 'log record date and time' is the date and time of the recorded log.
- THREAD('process Id', 'thread handle') is the information of log process id and thread handle.
- 'log prefix' is the entity or feature which created the log, and 'log body' is the detailed information.
- 'Log level' is the level of log recorded in system log, and its value is FATAL, ABORT, WARNING, INFO. 'log level' has the properties as follows.

**Table 5-5** Log level properties

| Log level | Description                                                       | Processing                                                                                                                                                                                                                                                 |
|-----------|-------------------------------------------------------------------|------------------------------------------------------------------------------------------------------------------------------------------------------------------------------------------------------------------------------------------------------------|
| FATAL     | The state which master or client process is shut down abnormally. | The client should be reconnected in case of client process FATAL, and the database instance should be shut down and restarted in case of system FATAL.<br>Backup the data file, control file, redo log file, system log file and contact the manufacturer. |
| ABORT     | The state to continue service after rollback.                     | It is the normal state for system operation. Execute it again after eliminating the rollback cause.                                                                                                                                                        |
| WARNING   | Operational warnings                                              | The abnormal state of database instance. there is no operational problem but cause analysis is needed.                                                                                                                                                     |
| INFO      | Operational information                                           | -                                                                                                                                                                                                                                                          |

For example, the following system log recorded the operational information at 17:30:55 on September 11 in 2014 by process id 21395 (The thread handle is 139982731163392). Log prefix is 'STARTUP-SM' and was executing the storage manager when the master process of GOLDILOCKS database started up. It means that the transition to NO-MOUNT phase had been done during multilevel startup.

```
[2014-09-11 17:30:55.758164 THREAD(21395,139982731163392)] [INFORMATION]
[STARTUP-SM] NO-MOUNT PHASE
```

## Operational Information of GOLDILOCKS Database

It is the log for creating database instance, multilevel startup and shutdown, loading data file, recovering restart and media. It records the necessary information for the operation of the master process from when master process starts up until it terminates.

- GOLDILOCKS instance creation log

The system log records the following information when database instance is created. It creates the control file after the transition to NO-MOUNT phase to create database.

```
=====
Startup GOLDILOCKS
```

```
TIME      : 2014-09-03 14:43:17.321020
=====
```

```
[2014-09-03 14:43:17.321134 THREAD(14979,140542517491456)] [INFORMATION]
[STARTUP-SM] NO-MOUNT PHASE
[2014-09-03 14:43:17.321658 THREAD(14979,140542517491456)] [INFORMATION]
[STARTUP-SM] DATA_STORE_MODE(2)
[2014-09-03 14:43:17.335809 THREAD(14979,140542517491456)] [INFORMATION]
... copy control file from '/goldilocks_data/wal/control_0.ctl' to
'/goldilocks_data/wal/control_1.ctl'
```

Then, it moves to transition to OPEN phase, and creates the system tablespace.

```
[2014-09-03 14:43:17.401356 THREAD(14979,140542517491456)] [INFORMATION]
[STARTUP-SM] MOUNT PHASE
[2014-09-03 14:43:19.319769 THREAD(14979,140542517491456)] [INFORMATION]
[STARTUP-SM] PRE-OPEN PHASE
[2014-09-03 14:43:19.320494 THREAD(14979,140542517491456)] [INFORMATION]
[STARTUP-SM] RECOVER TABLESPACE AND DATAFILE STATE
[2014-09-03 14:43:19.326269 THREAD(14979,140542517491456)] [INFORMATION]
[STARTUP-SM] OPEN PHASE
[2014-09-03 14:43:21.005536 THREAD(14979,140542517491456)] [INFORMATION]
[TABLESPACE] Create Tablespace(0)
[2014-09-03 14:43:21.005593 THREAD(14979,140542517491456)] [INFORMATION]
[TABLESPACE] Create Tablespace(1)
...
```

After creating the system tablespace, it executes checkpoint, and terminates the database instance.

```
[2014-09-03 14:43:21.788129 THREAD(14979,140542517491456)] [INFORMATION]
[CHECKPOINT] begin - checkpoint lid(0,10128,13), checkpoint lsn(10512), oldest lsn(10512)
[2014-09-03 14:43:21.788188 THREAD(14979,140542517491456)] [INFORMATION]
[CHECKPOINT] body - checkpoint lid(-1,0,0), checkpoint lsn(-1), active transaction count(0)
[2014-09-03 14:43:21.788203 THREAD(14979,140542517491456)] [INFORMATION]
[CHECKPOINT] end - checkpoint lid(0,10128,77), checkpoint lsn(10513)
[2014-09-03 14:43:21.788214 THREAD(14979,140542517491456)] [INFORMATION]
[CHECKPOINT] flush redo log
[2014-09-03 14:43:21.949589 THREAD(14979,140542517491456)] [INFORMATION]
[CHECKPOINT] save control file
[2014-09-03 14:43:21.957563 THREAD(14979,140542517491456)] [INFORMATION]
```

```
[SHUTDOWN-SM] CLOSE
[2014-09-03 14:43:21.957595 THREAD(14979,140542517491456)] [INFORMATION]
[SHUTDOWN-SM] POST CLOSE
[2014-09-03 14:43:21.992521 THREAD(14979,140542517491456)] [INFORMATION]
[SHUTDOWN-SM] DISMOUNT
[2014-09-03 14:43:21.992557 THREAD(14979,140542517491456)] [INFORMATION]
[SHUTDOWN-SM] INIT
```

- GOLDILOCKS instance startup log

Master process records logs such as multilevel startup of database instance, loading data file, restart recovery, media recovery. After the transition to MOUNT phase, the data file is loaded.

```
=====
Startup GOLDILOCKS
TIME      : 2014-09-03 14:43:22.162601
=====
[2014-09-03 14:43:22.162765 THREAD(14982,140025756808960)] [INFORMATION]
[STARTUP-SM] NO-MOUNT PHASE
[2014-09-03 14:43:22.163389 THREAD(14982,140025756808960)] [INFORMATION]
[STARTUP-SM] DATA_STORE_MODE(2)
[2014-09-03 14:43:22.429311 THREAD(14983,140025756808960)] [INFORMATION]
[STARTUP-SM] MOUNT PHASE
[2014-09-03 14:43:22.559395 THREAD(14983,140025756808960)] [INFORMATION]
[EVENT] system startup : SUCCESS
[2014-09-03 14:43:22.568526 THREAD(14981,139649517561600)] [INFORMATION]
[STARTUP] MOUNT PHASE
[2014-09-03 14:43:22.571200 THREAD(14983,140025756808960)] [INFORMATION]
[STARTUP-SM] LOAD DATAFILES
[2014-09-03 14:43:22.571241 THREAD(14983,140025756808960)] [INFORMATION]
.... datafile '/goldilocks_data/db/system_dict.dbf' assigned to PARALLEL_IO_GROUP_1
...
[2014-09-03 14:43:22.571562 THREAD(14983,140025280841472)] [INFORMATION]
.... LOAD DATAFILE(/goldilocks_data/db/system_dict.dbf)
...
```

After loading data file to the memory, it executes the recovery.

```
[2014-09-03 14:43:23.537256 THREAD(14983,140025756808960)] [INFORMATION]
[STARTUP-SM] REFINE TABLESPACE AND DATAFILE
[2014-09-03 14:43:23.631974 THREAD(14983,140025756808960)] [INFORMATION]
[RESTART REDO] begin
```

```
[2014-09-03 14:43:23.634374 THREAD(14983,140025756808960)] [INFORMATION]
[RESTART REOD] read checkpoint log - checkpoint log id(0,10128,13), oldest lsn(10512), system
scn(7)
[2014-09-03 14:43:23.756293 THREAD(14983,140025756808960)] [INFORMATION]
[RESTART RED0] ready to redo - start lid(0,10128,13), lsn(10512)
...
[2014-09-03 14:43:24.090755 THREAD(14983,140025756808960)] [INFORMATION]
[RESTART RED0] end - restart lsn(10514), restart scn(7)
[2014-09-03 14:43:24.091551 THREAD(14983,140025756808960)] [INFORMATION]
[RESTART UNDO] begin
[2014-09-03 14:43:24.091598 THREAD(14983,140025756808960)] [INFORMATION]
[RESTART UNDO] end
```

After recovery, it executes checkpoint, reflects the recovery result to disk data file. Then, it creates index, moves to the transition to OPEN phase.

```
[2014-09-03 14:43:24.111878 THREAD(14983,140025633163008)] [INFORMATION]
[CHECKPOINT] begin
...
[2014-09-03 14:43:24.129995 THREAD(14983,140025633163008)] [INFORMATION]
[CHECKPOINT] save control file
[2014-09-03 14:43:24.135864 THREAD(14983,140025633163008)] [INFORMATION]
[CHECKPOINT] end
[2014-09-03 14:43:24.144525 THREAD(14983,140025756808960)] [INFORMATION]
[STARTUP-SM] PRE-OPEN PHASE
[2014-09-03 14:43:24.202782 THREAD(14983,140025756808960)] [INFORMATION]
[STARTUP-SM] RECOVER TABLESPACE AND DATAFILE STATE
[2014-09-03 14:43:24.210158 THREAD(14983,140025756808960)] [INFORMATION]
[STARTUP-SM] REFINE RELATIONS
[2014-09-03 14:43:24.210304 THREAD(14983,140025756808960)] [INFORMATION]
[STARTUP-SM] REBUILD INDEXES
[2014-09-03 14:43:24.210375 THREAD(14983,140025756808960)] [INFORMATION]
[STARTUP-SM] OPEN PHASE
[2014-09-03 14:43:24.332064 THREAD(14983,140025756808960)] [INFORMATION]
[EVENT] system startup : SUCCESS
[2014-09-03 14:43:24.340843 THREAD(14981,139649517561600)] [INFORMATION]
[STARTUP] OPEN PHASE
```

- GOLDILOCKS instance termination log

When it shuts down database instance, it reflects all data file to the disk, executes checkpoint, then terminates the master process.

```

[2014-09-03 14:48:03.467293 THREAD(15416,139855812097792)] [INFORMATION]
[IO SLAVE] flush datafile ( tablespace : 0, datafile : 0 )
...
[2014-09-03 14:48:03.748958 THREAD(15416,139855908558592)] [INFORMATION]
[PAGE FLUSHER] flushed lsn(137496), flushed page count(9216)
[2014-09-03 14:48:03.761055 THREAD(15416,139856376227584)] [INFORMATION]
[CHECKPOINT] begin
...
[2014-09-03 14:48:03.780011 THREAD(15416,139856376227584)] [INFORMATION]
[CHECKPOINT] save control file
[2014-09-03 14:48:03.786387 THREAD(15416,139856376227584)] [INFORMATION]
[CHECKPOINT] end
[2014-09-03 14:48:03.791251 THREAD(15416,139856430274304)] [INFORMATION]
[SHUTDOWN-SM] CLOSE
[2014-09-03 14:48:03.791383 THREAD(15416,139856430274304)] [INFORMATION]
[SHUTDOWN-SM] POST CLOSE
[2014-09-03 14:48:03.824445 THREAD(15416,139856430274304)] [INFORMATION]
[SHUTDOWN-SM] DISMOUNT
[2014-09-03 14:48:03.824518 THREAD(15416,139856430274304)] [INFORMATION]
[EVENT] system shutdown : SUCCESS
[2014-09-03 14:48:04.267130 THREAD(15416,139856430274304)] [INFORMATION]
[SHUTDOWN-SM] INIT

```

If \shutdown abort forcibly stopped the server, neither checkpoint, nor is normal server shutdown executed.

```

[2014-09-03 14:51:45.353154 THREAD(8989,139949509089024)] [INFORMATION]
[SHUTDOWN] skip CLOSE phase
[2014-09-03 14:51:45.678461 THREAD(8989,139949509089024)] [INFORMATION]
[SHUTDOWN] skip DISMOUNT phase
[2014-09-03 14:51:45.678696 THREAD(8989,139949509089024)] [INFORMATION]
[EVENT] system shutdown : SUCCESS
[2014-09-03 14:51:45.678928 THREAD(8989,139949509089024)] [INFORMATION]
[SHUTDOWN-SM] INIT

```

- The logs of master process checkpoint, log flusher, log archiving, ager, parallel IO, cleanup thread during database operation

A checkpoint reflects to disk all data files which are updated only in memory and not written to the disk yet at checkpoint time. If it uses the parallel IO, it executes parallel IO in data file units. One unit of checkpoint log is from '[CHECKPOINT] begin' to '[CHECKPOINT] end'.



[IO SLAVE] is a log which is recorded by IO thread dedicated to parallel IO. '[IO SLAVE] flush data file (tablespace: 0, datafile: 0)' log is recorded after the data file (whose datafile id is '0' and whose tablespace id is 0) is reflected to the disk. These data file flush logs are repeatedly recorded as many as the number of data file at checkpoint time.

'[PAGE FLUSHER] flushed lsn(139039), flushed page count(9216)]' means that the reflected minimum Lsn in the disk is 139039, and reflected pages are 9216. The last log Lsn archives redo log files which are smaller than 139039. They record checkpoint log and control file, then stores them in the disk.

If a database is large its checkpoint time will be longer. Check if the datafile is continuously being recorded by tracking [IO SLAVE] logs. And if disk IO does not operate and stops, then check if log archiving is in progress. If the space is insufficient, then spare the space and ensure the log archiving proceed normally.

If checkpoint fails '[CHECKPOINT] CHECKPOINT was failed' log will be recorded. The checkpoint can be specially omitted at checkpoint time due to the log file switch, where '[CHECKPOINT] CHECKPOINT was skipped' log might be recorded.

```
[2014-09-12 15:54:59.654427 THREAD(13780,140493515450112)] [INFORMATION]
[CHECKPOINT] begin
[2014-09-12 15:54:59.654798 THREAD(13780,140493029623552)] [INFORMATION]
[IO SLAVE] flush datafile ( tablespace : 0, datafile : 0 )
[2014-09-12 15:54:59.835173 THREAD(13780,140493029623552)] [INFORMATION]
[IO SLAVE] flush datafile ( tablespace : 1, datafile : 0 )
[2014-09-12 15:54:59.893991 THREAD(13780,140493029623552)] [INFORMATION]
[IO SLAVE] flush datafile ( tablespace : 2, datafile : 0 )
[2014-09-12 15:54:59.926753 THREAD(13780,140493050603264)] [INFORMATION]
[PAGE FLUSHER] flushed lsn(138895), flushed page count(9216)]
[2014-09-12 15:54:59.926989 THREAD(13780,140492777965312)] [INFORMATION]
[ARCHIVING] stable lsn(139039)
[2014-09-12 15:54:59.933780 THREAD(13780,140493515450112)] [INFORMATION]
[CHECKPOINT] begin - checkpoint lid(0,55527,13), checkpoint lsn(139040), oldest lsn(139040)
[2014-09-12 15:54:59.933825 THREAD(13780,140493515450112)] [INFORMATION]
[CHECKPOINT] body - checkpoint lid(0,55527,77), checkpoint lsn(139041), active transaction
count(1)
[2014-09-12 15:54:59.933844 THREAD(13780,140493515450112)] [INFORMATION]
[CHECKPOINT] end - checkpoint lid(0,55527,155), checkpoint lsn(139042)
[2014-09-12 15:54:59.933859 THREAD(13780,140493515450112)] [INFORMATION]
[CHECKPOINT] flush redo log
[2014-09-12 15:54:59.936154 THREAD(13780,140493515450112)] [INFORMATION]
[CHECKPOINT] save control file
[2014-09-12 15:54:59.942850 THREAD(13780,140493515450112)] [INFORMATION]
[CHECKPOINT] end
```

Log flusher records the system log when the log buffer stops flushing to disk, and when it restarts the stopped flusher. If the next log group is not reusable log file, the logging stops until it becomes reusable. The following describes an example when the logging is stopped because the redo log file of which sequence number is 34 has not been archived.

```
[2014-09-12 16:01:57.514303 THREAD(13780,14057333325568)] [INFORMATION]
[LOG FLUSHER] disable logging - blocked lfsn(34)
```

If the logging stops, then the transaction stops, so an immediate action is needed. When checkpoint is executed and archiving is done, the logging will restarts.

```
[2014-09-12 16:01:58.079236 THREAD(13780,140380267869952)] [INFORMATION]
[ARCHIVING] enable logging - blocked lfsn(34), inactivated lfsn(34)
```

Log archiving thread archives the redo log file of ACTIVE state, and it records the system log. One unit is from '[ARCHIVING] stable lsn(...)' to '[ARCHIVING] inactivate group ...'. If database is operated in archive log mode, the redo file archiving log(from '[ARCHIVELOG BEGIN] ...' to '[ARCHIVELOG END] ...') is recorded.

```
[2014-09-02 17:41:56.762950 THREAD(20800,140129584793344)] [INFORMATION]
[ARCHIVING] stable lsn(144143)
[2014-09-02 17:41:56.763549 THREAD(20800,140129584793344)] [INFORMATION]
[ARCHIVELOG BEGIN] LOG(/goldilocks_data/wal/redo_0_0.log(8)) =>
ARCHIVE(/goldilocks_data/archive_log/archive_8.log)
[2014-09-02 17:41:57.385936 THREAD(20800,140129584793344)] [INFORMATION]
[ARCHIVELOG END] (/goldilocks_data/archive_log/archive_8.log) : SUCCESS
[2014-09-02 17:41:57.385987 THREAD(20800,140129584793344)] [INFORMATION]
[ARCHIVING] inactivate group #0(8)
```

If the log '*Archiving was failed - ...*' outputs after the log '[ARCHIVELOG BEGIN] ...', then log archiving is failed. This failure should be immediately resolved in order that the service will be enabled by reusing the redo log file in active state.

The table whose age is dropped and the aging information for the tablespace will be recorded as follows. When dropping the table, the table lock is also deleted, and the table scn information, scn which is able to aging at aging time and the aging information of table lock will be recorded. If a table has an index, it will be deleted when dropping the table.

```
[2014-09-03 12:13:56.539971 THREAD(5225,139821699815168)] [INFORMATION]
[AGER] aging index - object scn(224), type(0), physical id(22634477649920)
[2014-09-03 12:13:56.540388 THREAD(5225,139821699815168)] [INFORMATION]
[AGER] aging table - object scn(224), object view scn(225), type(0), physical
```

```
id(22630182682624)
[2014-09-03 12:13:56.540491 THREAD(5225,139821699815168)] [INFORMATION]
[AGER] aging lock item - object scn(226), agable stmt scn(228), physical id(22630182682624)
```

When deleting a tablespace, tablespace scn, aging available scn at aging time and dropped tablespace id are recorded.

```
[2014-09-03 12:13:56.540553 THREAD(5225,139821699815168)] [INFORMATION]
[AGER] aging tablespace - object scn(224), object view scn(227), tablespace id(5)
```

The cleanup thread records the information about abnormally terminated session as follows. Even when a user session is abnormally terminated, the resources of the session is cleaned up, so the database instance or other users continue to operate.

```
[2014-09-03 13:43:02.220139 THREAD(7768,140298504156928)] [WARNING]
[CLEANUP] snipe at zombie session - pid(7766), thread(139967223228160), program(gsql)
[2014-09-03 13:43:02.220211 THREAD(7768,140298504156928)] [WARNING]
[CLEANUP] cleaning session - env(3), session(4), transaction(FFFFFFFFFFFFFFFF), program(gsql),
pid(7766), thread(139967223228160)
[2014-09-03 13:43:02.220270 THREAD(7768,140298504156928)] [WARNING]
[CLEANUP] cleaning up 1 sessions
```

- Log of creating, dropping, altering tablespace by a user

The system log records the operations of creating, deleting, updating of a user tablespace. Tablespace related to DDL is recorded by default, regardless of TRACE\_DDL ON/OFF. DDL failure will not be recorded in the system log. Therefore, a user should operate the system by setting TRACE\_DDL to *ON* in order to figure out more details about DDL log and the causes of its failure.

```
[2014-09-15 10:26:41.649909 THREAD(24881,140468897289984)] [INFORMATION]
[TABLESPACE] Create Tablespace(7)
[2014-09-15 10:26:55.966385 THREAD(24881,140468897289984)] [INFORMATION]
[DATAFILE] add datafile(/home/zkyungoh/work/product/Gliese/home/db/TEST1.dbf)
[2014-09-15 10:27:11.325897 THREAD(24881,140468897289984)] [INFORMATION]
[DATAFILE] Drop Datafile(/home/zkyungoh/work/product/Gliese/home/db/TEST1.dbf)
...
[2014-09-15 10:32:00.669550 THREAD(24881,140468897289984)] [INFORMATION]
[TABLESPACE] drop tablespace ( 7 )
```

- System internal error and index creation failure log

An internal error occurs when GOLDLOCKS database system error occurs but the exact cause of the failure

re can not be defined. If an internal error occurs, the SQL statement which raised the error is rolled back. The service is continuously available because the error does not affect the system nor does other sessions.

By the way, if the error raising SQL statement is executed again, it could be failed for the same reason, or the cause of failure could disappear and the operation could succeed. Therefore, a user should not change the database at the point of failure, but should request cause analysis to find the cause.

The index creation fails if the same key index on a table exists when creating UNIQUE index. Even though the index creation fails, it does not affect the index tables which are already created. Therefore, it does not affect the service.

```
[2014-09-15 11:26:59.640345 THREAD(7819,140737354012416)] [INFORMATION]
Index creation failed ( physical id : 22638772617216, error code : 14016 )
```

## XA Log

It records the success or failure log of start, close, end, rollback, prepare, commit, recover, forget operations of XA transaction interface for processing distributed transactions. GOLDILOCKS database does not record XA trace log by default. TRACE\_XA should be set to *ON* to record the XA trace log as follows. For more information, refer to **XA API References**.

```
gSQL> alter system set trace_xa = yes;
System altered.
```

XA trace log is recorded in 'xa.trc' as follows. At first, executed XA interface is recorded, and then the status (*complete* or *failed*) is recorded. The information such as session id and transaction id is also recorded. If it fails, the error code defined in **XA API References** is recorded.

```
[2014-09-15 11:45:19.599018 THREAD(7966,139931504572160)] [INFORMATION]
xa_start() complete - session(4), xid(0.3231.00), flags(0)
[2014-09-15 11:45:19.599360 THREAD(7966,139931504572160)] [INFORMATION]
xa_end() complete - session(4), xid(0.3231.00), flags(4000000)
[2014-09-15 11:45:19.599418 THREAD(7966,139931504572160)] [INFORMATION]
xa_prepare() complete - session(4), xid(0.3231.00), flags(0)
[2014-09-15 11:45:22.864563 THREAD(7966,139931504572160)] [INFORMATION]
xa_recover() complete - session(4), xid(), flags(1000000)
[2014-09-15 11:45:22.864829 THREAD(7966,139931504572160)] [INFORMATION]
xa_commit() complete - session(4), xid(0.3231.00), flags(0)
[2014-09-15 11:45:22.864887 THREAD(7966,139931504572160)] [INFORMATION]
xa_rollback() complete - session(4), xid(0.3232.00), flags(0)
[2014-09-15 11:45:22.885951 THREAD(7966,139931504572160)] [INFORMATION]
xa_forget() complete - session(4), xid(0.3230.00), flags(0)
```

```
[2014-09-15 11:45:22.886017 THREAD(7966,139931504572160)] [INFORMATION]
xa_forget() failed - session(4), xid(0.3231.00), flags(0), xa_error(-4)
```

## DDL Log

For all DDL (creating, dropping, altering) generated in GOLDILOCKS database, the DDL generating sessions, overall SQL statements, status of success or failure are added in system log. In GOLDILOCKS database, DDL log is not recorded by default. TRACE\_DDL should be set to *ON* as follows to record DDL trace log.

```
gSQL> alter system set trace_ddl = yes;
System altered.
```

The followings describe an example of which DDL log is recorded when a tablespace is created using the DDL.

```
gSQL> CREATE TABLESPACE TEST_TBS1
DATAFILE 'TEST_TBS1_01.dbf' SIZE 10M,
          'TEST_TBS1_02.dbf' SIZE 10M,
          'TEST_TBS1_03.dbf' SIZE 10M;
Tablespace created.
```

```
[2014-09-15 12:26:29.209210 THREAD(8149,140267442067200)] [INFORMATION]
[SESSION:11][DDL success] CREATE TABLESPACE TEST_TBS1
DATAFILE 'TEST_TBS1_01.dbf' SIZE 10M,
          'TEST_TBS1_02.dbf' SIZE 10M,
          'TEST_TBS1_03.dbf' SIZE 10M
[2014-09-15 12:26:29.209277 THREAD(8149,140267442067200)] [INFORMATION]
[SESSION:11][COMMIT with DDL]
```

If DDL statement fails, 'DDL failure' is recorded as follows.

```
gSQL> ALTER TABLESPACE TEST_TBS1 ADD DATAFILE 'TEST_TBS1_04.dbf' SIZE 10M;
ERR-42000(16130): file is already exist -
'/home/zkyungoh/work/product/Gliese/home/db/TEST_TBS1_04.dbf' :
ALTER TABLESPACE TEST_TBS1 ADD DATAFILE 'TEST_TBS1_04.dbf' SIZE 10M
          *
ERROR at line 1:
```

```
[2014-09-15 12:45:08.598789 THREAD(8115,140191085913856)] [INFORMATION]
[SESSION:4][DDL failure] ALTER TABLESPACE TEST_TBS1 ADD DATAFILE 'TEST_TBS1_01.dbf' SIZE 10M
```

DDL log for table or index DDL statement is recorded in the same way. After creating a table or an index,

the committed DDL log is as follows.

```
gSQL> CREATE TABLE T1 ( I1 NATIVE_INTEGER ) TABLESPACE TEST_TBS1;
Table created.
gSQL> CREATE INDEX T1X ON T1 ( I1 );
Index created.
gSQL> COMMIT;
Commit complete.
```

```
[2014-09-15 12:40:37.887952 THREAD(8115,140191085913856)] [INFORMATION]
[SESSION:4][DDL success] CREATE TABLE T1 ( I1 NATIVE_INTEGER ) TABLESPACE TEST_TBS1
[2014-09-15 12:40:47.451806 THREAD(8115,140191085913856)] [INFORMATION]
[SESSION:4][DDL success] CREATE INDEX T1X ON T1 ( I1 )
[2014-09-15 12:40:51.017975 THREAD(8115,140191085913856)] [INFORMATION]
[SESSION:4][COMMIT with DDL]
```

The following is a rollback DDL log after creating a table or an index.

```
[2014-09-15 12:42:27.367722 THREAD(8115,140191085913856)] [INFORMATION]
[SESSION:4][DDL success] CREATE TABLE T1 ( I1 NATIVE_INTEGER ) TABLESPACE TEST_TBS1
[2014-09-15 12:42:31.317436 THREAD(8115,140191085913856)] [INFORMATION]
[SESSION:4][DDL success] CREATE INDEX T1X ON T1 ( I1 )
[2014-09-15 12:42:34.601738 THREAD(8115,140191085913856)] [INFORMATION]
[SESSION:4][ROLLBACK with DDL]
```

## Trace Log Replication

Replication trace log is recorded in a separate file when using GOLDILOCKS' replication tool such as CYCLONE and LOGMIRROR. For more information about replication trace log, refer to **operating CYCLONE** in CYCLONE chapter and **operating** in LOGMIRROR chapter.

## Listener Log

The errors and information which occurs from the startup of listener process until the end of the process are recorded in the listener log.

## Listener Log Format

The listener log is recorded in the following format.

```
['log recorded date and time' THREAD('process id', 'thread handle')]
['log prefix'] 'log body'
```

- 'log record date and time' is the date and time of the recorded log.
- THREAD ('process Id', 'thread handle') is the information of log process id and thread handle.
- 'log prefix' is the entity or feature which created the log, and 'log body' is the detailed information.

## Monitoring Performance Using View

Concurrency control for multi-user is needed because database is accessed or updated by multiple users at the same time. The concurrency should be provided for system data and shared resources as well as explicit data by SQL statements. GOLDILOCKS controls the concurrency using latch.

The concurrency control using lock can cause a deadlock when same data is updated by multiple different transactions. The concurrency control using latch (supported by GOLDILOCKS) can cause a deadlock, too. It is because the deadlock affects the performance, so a view is provided to handle the latch when a deadlock occurs.

The transactions generating the deadlock will be found when using V\$LOCK\_WAIT. Then, the administrator should monitor them, and unlock the deadlock. For more information about V\$LOCK\_WAIT, refer to V\$LOCK\_WAIT. For more information for monitoring latch item causing the deadlock, refer to V\$LATCH.





**6.**

---

## **Structure and Storage Structure of GOLDILOCKS Database**

## 6.1 Managing Control File

A database instance should be created to use GOLDILOCKS database, and the control file is created when creating a database instance. The information is written on the control file when GOLDILOCKS multilevel startup moves from nomount level to mount level. The absolute path and the size of the file to be used in database are recognized by using the recorded information on the control file. The control file is a binary file and database information is stored as follows.

### Control File Contents

**Table 6-1** GOLDILOCKS database system information

| Item                | Description                                                                         |
|---------------------|-------------------------------------------------------------------------------------|
| Data store mode     | It stores mode which is set when database starts up. (TDS, CDS)                     |
| Server state        | It is the database instance state. (NONE, RECOVERED, RECOVERING, SERVICE, SHUTDOWN) |
| Last checkpoint lsn | It is the LSN of the checkpoint which was executed last in the database.            |

**Table 6-2** Log information

| Item                               | Description                                                                                              |
|------------------------------------|----------------------------------------------------------------------------------------------------------|
| Checkpoint lid, lsn                | It is the log information (LSN, log position) of the checkpoint which was executed last in the database. |
| Last inactivated log file sequence | It is the log file sequence which was changed to inactive last.                                          |
| Archivelog mode                    | It is the archivelog mode of the database in operation.                                                  |
| Creation time                      | It is the database created time.                                                                         |

Database information stores information about database operating, all tablespace in use, and data. The database operating information stored in the control file is as follows.

**Table 6-3** Database information

| Item                   | Description                                                      |
|------------------------|------------------------------------------------------------------|
| Transaction table size | It is the maximum number of using transaction table in database. |
| Undo relation count    | It is the number of using undo relations in database.            |
| Tablespace count       | It is the number of tablespaces in use created in database.      |
| New tablespace id      | It is the tablespace ID to be created later.                     |

Tablespace information is stored in the control file as follows.

**Table 6-4** Tablespace information

| Item                 | Description                                                                                                                                                                                                                                                                                                                                                                                         |
|----------------------|-----------------------------------------------------------------------------------------------------------------------------------------------------------------------------------------------------------------------------------------------------------------------------------------------------------------------------------------------------------------------------------------------------|
| Tablespace id        | It is a unique tablespace ID.                                                                                                                                                                                                                                                                                                                                                                       |
| Attributes           | It is the attribute of a tablespace such as storage device (memory, disk), persistence attribute (temporary, persistent), tablespace usage (dictionary, undo, data, temporary).                                                                                                                                                                                                                     |
| Page count in extent | It is the number of extent pages.                                                                                                                                                                                                                                                                                                                                                                   |
| State                | It is the tablespace status. (CREATING, CREATED, DROPPING, DROPPED, AGING)                                                                                                                                                                                                                                                                                                                          |
| Relation id          | It is the relation ID to store pending operation of tablespace.                                                                                                                                                                                                                                                                                                                                     |
| New data file id     | It is the data file ID which is set when new data file is inserted to tablespace.                                                                                                                                                                                                                                                                                                                   |
| Is logging           | It is the logging mode of a tablespace. (LOGGING, NOLOGGING)                                                                                                                                                                                                                                                                                                                                        |
| Is online            | It is the online or offline status of a tablespace. (ONLINE, OFFLINE)                                                                                                                                                                                                                                                                                                                               |
| Data file count      | It is the number of data files used by a tablespace.                                                                                                                                                                                                                                                                                                                                                |
| Offline lsn          | It is the last LSN which executes recovery if needed, in order to shift offline tablespace to online.                                                                                                                                                                                                                                                                                               |
| Offline state        | It is the status of offline tablespace. (CONSISTENT, INCONSISTENT)<br>CONSISTENT offline tablespace does not have to be recovered when shifting the status to online. It is because the tablespace status is shifted to offline after the most recent data in memory is stored to disk. On the other hand, INCONSISTENT offline tablespace executes recovery using the log when shifting to online. |

Data file information is stored in the control file as follows.

**Table 6-5** Data file information

| Item                | Description                                                                                                     |
|---------------------|-----------------------------------------------------------------------------------------------------------------|
| Name                | It is the data file name including the absolute path which stores data.                                         |
| State               | It is the data file status. (CREATING, CREATED, DROPPING, DROPPED, AGING)                                       |
| Data file id        | It is the unique data file ID in a tablespace.                                                                  |
| Auto extend         | It is whether to extend automatically or not when a data file is full.                                          |
| Size                | It is the data file size.                                                                                       |
| Next size           | It is the size to be extend when a data file is full.                                                           |
| Max size            | It is the maximum size of extendable data file.                                                                 |
| Timestamp           | It is the time when data file was created.                                                                      |
| Checkpoint lsn, lid | It is the checkpoint log information when the last checkpoint is executed in the data file. (LSN, log position) |
| Creation lsn, lid   | It is the checkpoint log information of when a data file is created. (LSN, log position)                        |

It stores each incremental backup information operated in the database. GOLDILOCKS database supports the incremental backup for database and tablespaces, and the incremental backup information is stored in the control file as follows.

**Table 6-6** Incremental backup information

| Item             | Description                                                                                                                                                                                                                                                       |
|------------------|-------------------------------------------------------------------------------------------------------------------------------------------------------------------------------------------------------------------------------------------------------------------|
| Backup lsn, lid  | It is the checkpoint log information which was executed last at the beginning of backup. (LSN, log position)                                                                                                                                                      |
| Begin time       | It is the incremental backup beginning time.                                                                                                                                                                                                                      |
| Completion time  | It is the incremental backup completion time.                                                                                                                                                                                                                     |
| Tablespace id    | It is the unique tablespace ID of which an incremental backup is executed. If incremental backup for a tablespace is executed, its tablespace ID is recorded. If the backup is not executed for a tablespace, then the maximum tablespace ID (65535) is recorded. |
| Level            | It is the level of executed incremental backup.                                                                                                                                                                                                                   |
| Object type      | It is the target of incremental backup. (database, control file, tablespace)                                                                                                                                                                                      |
| Backup file name | It is the name of the incremental backup file.                                                                                                                                                                                                                    |
| Backup option    | It is the incremental backup option. (cumulative, differential)                                                                                                                                                                                                   |

## Multiplexing Control File

The control file stores the physical structure of GOLDILOCKS database and the information on data consistency. If the control file is corrupted or deleted by mistake, it is not possible to operate database.

Therefore, GOLDILOCKS database recommends creating at least two or more control files and keep them in physically separated disks. GOLDILOCKS supports multiplexing up to 8. To add control files when creating a database, set the number of multiplexing control files in the property file, and set the path of each control file. To add control files when operating database, increase the property value for control file multiplexing, and add the control file paths.

## Restoring Corrupted Control File

If a control file is corrupted due to database's abnormal termination, the corrupted control file is restored using a normal control file among multiplexed control files, and then it is restarted.

If all multiplexed control files are corrupted, the backup control file is restored, and the incomplete media recovery is executed for archive redo log files and redo log files, and then it is restarted. For more information about incomplete recovery using the backup control file, refer to **When all multiplexed control files are corrupted** in recovery examples.

## Control File Information

A user can enquire the control file name by using V\$CONTROLFILE which is the performance view to retrieve the location and the name of the control file as follows.

```
gSQL> SELECT CONTROLFILE_NAME FROM V$CONTROLFILE;
CONTROLFILE_NAME
-----
/goldilocks_data/wal/control_0.ctl
/goldilocks_data/wal/control_1.ctl
2 rows selected.
```

A user can retrieve the correct information written in the control file using **gdump** the dump tool of GOLDILOCKS.

## 6.2 Managing Redo Log File

GOLDILOCKS uses the redo log files to ensure database persistency. In other words, the database can be restored to the state before shutdown database using the redo log files and data files when GOLDILOCKS database is abnormally terminated due to various reasons.

In order to do so, GOLDILOCKS database uses Write Ahead Logging (WAL) policy to store log of all update operations.

The updated data by the update operation is not recorded in the data file, but the log for the update operation is recorded in the redo log file. It is because it is much more efficient in the terms of database performance. Whenever each update operation is recorded in the data file, a random access occurs and the update operations for the same file causes the excessive disk IO. However, the update log is smaller than the updated data, and it performs the efficient disk IO in a way being appended at the end of log file.

GOLDILOCKS database uses log buffer in shared memory to record the updated logs to the log buffer, and then records log buffer to the log file all together, and it leads to more efficient disk IO.

### Redo Log File Structure

The redo log buffer and log file in GOLDILOCKS have a circular structure. The log files are created as many as predefined number of log groups, and then they record logs. If a log file is full, the following log file is used. When all log files are used up, the previously used log file is reused. The log file is a circular structure consisting of a single log group of several members. GOLDILOCKS performs the logging using minimum four log groups.

**Figure 1** GOLDILOCKS redo log file, log buffer structure

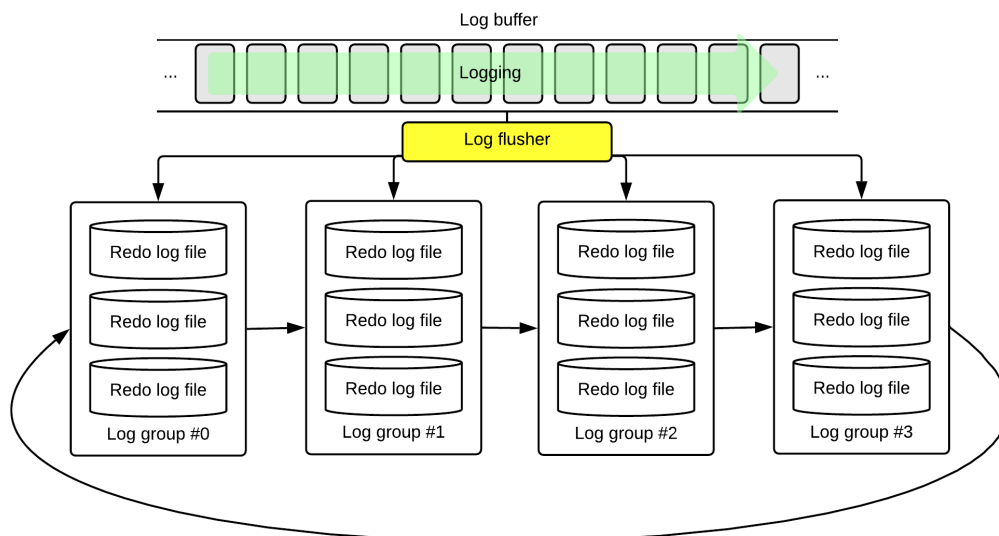

## Redo Log Group and Its Member

GOLDILOCKS database uses a log group and members to record logs to the disk log file during database operation. A single redo log file is a member of a log group, and a log group consists of several log members. Log group which consists of many members ensures high availability because other log members can be used when a particular disk fails or a particular log member is corrupted.

The system records logs to a log group, and if the log group is full, the following group is used. This is a circular log group. The currently used log group shifts to the following log group one and this is called as log switching.

A log group, the number of members and each of its position are set by the property when creating database. They can be altered by adding or dropping syntax when operating database.

### Log Group State

The state of log group is initialized to UNUSED when creating it. It is changed to CURRENT, ACTIVE, and INACTIVE state by the system during operation.

**Table 6-7** GOLDILOCKS log group state

| Log group state | Description                                                           |
|-----------------|-----------------------------------------------------------------------|
| UNUSED          | The log group has never been used after creation.                     |
| CURRENT         | The log group is being used by the current system.                    |
| ACTIVE          | It is not yet ready to be reused after CURRENT log group is switched. |
| INACTIVE        | ACTIVE state log group is ready to be reused.                         |

ACTIVE log group can not be reused in the system, but it can be reused after it is changed to INACTIVE by archive log thread. Archive log thread wakes up by an event before the checkpoint is completed, and it changes ACTIVE log groups to INACTIVE state. In order to do so, log archiving thread archives log file in ACTIVE log group, then change it to INACTIVE when the system is operated in ARCHIVELOG mode. If the system is operated in NOARCHIVELOG mode, then the ACTIVE log group is immediately reusable after changing the log group state to INACTIVE.

## Adding Log Group and Log Member

### Adding Log Group

Adding log group is allowed only in mount phase of GOLDILOCKS database multilevel startup. The new log group is added next to the CURRENT state of the log group which is currently being used.

The following is an example to add a new log group whose file name is 'abc.log', and file size is 20 Mbytes to group ID 10.

```
ALTER DATABASE ADD LOGFILE GROUP 10 ('abc.log') SIZE 20M;
```

## Adding Log Member

A new log member can be added for the stability of log group in use. It can be added in mount phase of GOLDILOCKS database multilevel startup in the same way of adding log group. The following is an example to add the log file named as 'test log' to group ID 10. The log file size is not specified because the log member size in a log group is same.

```
ALTER DATABASE ADD LOGFILE MEMBER 'test.log' TO GROUP 10;
```

## Altering Log Member Name

The position and the file name of the log member in use can be altered by executing RENAME in mount phase. RENAME is executed for log member when the log member's disk is physically failed or the log member should be transferred to another disk in terms of performance.

The following is an example to RENAME the log file '/disk1/goldilocks\_data/wal/redo\_0\_0.log' to the log file '/disk2/goldilocks\_data/wal/redo\_0\_0.log'.

```
ALTER DATABASE RENAME LOGFILE '/disk1/GOLDILOCKS_data/wal/redo_0_0.log' TO  
'/disk2/GOLDILOCKS_data/wal/redo_0_0.log';
```

## Dropping Log Group or Log Member

A log member or log group in use can be dropped in mount phase when a user wants to reduce log groups, log members or when log file disk is failed.

The following is an example to drop all members of log group ID 10.

```
ALTER DATABASE DROP LOGFILE GROUP 10;
```

Dropping log member is allowed only when at least two members exist in the log group.

The following is an example to drop the '/disk1/goldilocks\_data/wal/redo\_0\_0.log' log member.

```
ALTER DATABASE DROP LOGFILE MEMBER '/disk1/GOLDILOCKS_data/wal/redo_0_0.log';
```

## Restoring Corrupted Redo Log File

If the system fails and the redo log files are corrupted, then the restart recovery fails and the system cannot be operated. If normal log members exist in the corrupted log group, the restart recovery and the system



m operation can be executed by copying the log file of the normal log member to the corrupted log files.

If all log files in a log group are corrupted or there is only one log member, it can be restarted by executing incomplete media recovery. The incomplete media recovery is restricted to the normal log file.

For more information about incomplete media recovery, refer to **Incomplete Recovery**.

## Redo Log File Information

A user can enquire V\$LOGFILE which is a performance view to retrieve the location and the name of the redo log files. When inquiring V\$LOGFILE, the log file name, its log group ID, its state, the file size are retrieved as follows.

```
gSQL> SELECT FILE_NAME, GROUP_ID, GROUP_STATE, FILE_SIZE FROM V$LOGFILE;
FILE_NAME                                GROUP_ID GROUP_STATE FILE_SIZE
-----
/disk1/goldilocks_data/wal/redo_0_0.log    0  INACTIVE   104857600
/disk1/goldilocks_data/wal/redo_1_0.log    1  CURRENT    104857600
/disk1/goldilocks_data/wal/redo_2_0.log    2  UNUSED     104857600
/disk1/goldilocks_data/wal/redo_3_0.log    3  UNUSED     104857600
4 rows selected.
```

## 6.3 Managing Archive Redo Log File

The database should be operated in archive log mode for media recovery using backup, because GOLDILOCKS redo log file reuses log group which is used when *circular* structure log group is used. Then the written completed redo log files are copied to the archive redo log files.

For more information about GOLDILOCKS database's archive log mode, refer to **ARCHIVELOG Mode**.

### Creating Archive Redo Log File

The redo log file is copied to archive redo log file directory by log archiving thread which is GOLDILOCKS database's system thread. Log archiving thread is activated by checkpoint thread during checkpoint, and it archives the proper object among redo log files.

Archive redo log file is created in the directory set by the ARCHIVELOG\_DIR\_1 property. The name of archive redo log file is composed of its prefix set by the ARCHIVELOG\_FILE property and of the sequence number of each redo log file.

### Maintaining and Dropping Archive Redo Log File

Media recovery using backup can fail if archive redo log files, similarly to the redo log files, are arbitrarily dropped. Therefore, archive redo log files should be saved with backup files, and the archive redo log files for media backup can be dropped when the backup file is not needed any more.

Backup is copying the data file which is downloaded to the disk by the most recent checkpoint. Therefore, the archive log files of the oldest LSN and later are needed to recover media using backup. Checkpoint is executed by the system when redo log file is switched, so one or more checkpoint logs exist in every log file except for the redo file in CURRENT state.

The followings describe how to get the archive redo log file required for media recovery using backup file.

1. Get the checkpoint LSN which is recorded in the file header of backup data files.
2. Dump the archive redo log file, and get the archive redo log file including checkpoint LSN.
3. The archive redo log file needed for the media recovery using backup begins just before the archive redo log file of No. 2.

Dump the control file and get the checkpoint LSN to get the archive redo log file needed for incremental backup. Subsequent process is as same as the entire backup process.

If backup files are not needed any more, the archive redo log file required for the media recovery using ba

ckup can be removed.

## Multiplexing Archive Redo Log File Directory

If the archive redo log file is moved from the directory set in ARCHIVELOG\_DIR\_1 to the other directory or media to preserve the archive redo log file, the media recovery fails because it can not find the required archive redo log file.

Move the archive redo log file back to the directory set in ARCHIVELOG\_DIR\_1 to resolve this problem. Or set the archive log files existing directory to ARCHIVELOG\_DIR\_2 ~ ARCHIVELOG\_DIR\_10, and add archive redo file directory for media recovery. READABLE\_ARCHIVELOG\_DIR\_COUNT should be set as many as the number of directory when using ARCHIVELOG\_DIR\_2 ~ ARCHIVELOG\_DIR\_10 for the media recovery.

## 6.4 Managing Tablespace

All the data used in database are stored in physical disk file, and use the database's logical structure for efficient data management and performance. GOLDILOCKS manages the disk space efficiently by using the logical structure such as tablespace, segment, extent, and page.

A tablespace can include multiple data files, and each tablespace is set to online/offline to support high data availability. Distributing data storing disks improves the IO performance, and reduces the contention of physical disk IO.

### Tablespace Type

GOLDILOCKS tablespace is divided into SYSTEM tablespace and non-SYSTEM tablespace. SYSTEM tablespace is created when database is created, and it is used and controlled only by the GOLDILOCKS system. Non-SYSTEM tablespace is created and used by a user.

#### SYSTEM Tablespace

It is created when GOLDILOCKS database is created, and it is essential for database operation. There are dictionary tablespace, undo tablespace and system temporary tablespace.

#### Non-SYSTEM Tablespace

It is a tablespace in which tables and indexes are stored for data storing, and a user can arbitrarily creates or drops.

## Managing Tablespace and Data File

### Managing Tablespace

#### Managing Tablespace State

The GOLDILOCKS database tablespace state is divided into online and offline. The offline tablespace is not accessible. A user can arbitrarily set the tablespace state to offline. Or, an abnormal tablespace can be set to offline by the system. The system tablespace should not be set to offline.

- Offline tablespace

GOLDILOCKS database flushes all data files in the tablespace to disk before the tablespace is set to offline. All related logs should be flushed to disk to flush data file. Therefore, a recovery is not needed when switching to online later. However, it is applied when DDLs occurred in the offline tablespace state is changed to online state.

A tablespace can be immediately set to offline using IMMEDIATE mode, without flushing data file. In this case, the tablespace state is changed to online after media recovery when setting the tablespace to online.

**Table 6-8** Tablespace offline option

| Option    | Description                                                                               | Media recovery when setting the tablespace to online |
|-----------|-------------------------------------------------------------------------------------------|------------------------------------------------------|
| NORMAL    | Flushing all the data file related logs in tablespace to the disk, then set it to offline | Media recovery is not required.                      |
| IMMEDIATE | Immediately setting a tablespace to offline                                               | Media recovery is required.                          |

GOLDILOCKS can set tablespace to offline in mount phase. To do so, the service should be normally terminated, or the server should be operated in ARCHIVELOG mode. This method provides high availability by performing service excluding the unrecoverable tablespaces when starts up database.

```
gSQL> ALTER TABLESPACE TEST_TBS OFFLINE;
```

```
Tablespace altered.
```

```
gSQL> ALTER TABLESPACE TEST_TBS ONLINE;
```

```
Tablespace altered.
```

```
gSQL> ALTER TABLESPACE TEST_TBS OFFLINE IMMEDIATE;
```

```
Tablespace altered.
```

```
gSQL> ALTER TABLESPACE TEST_TBS ONLINE;
```

```
ERR-42000(14051): media recovery required - 'TEST_TBS'
```

```
gSQL> ALTER DATABASE RECOVER TABLESPACE TEST_TBS;
```

```
Database altered.
```

```
gSQL> ALTER TABLESPACE TEST_TBS ONLINE;
```

Tablespace altered.

## Attributes of Tablespace

The followings are attributes of tablespace in GOLDBLOCKS database. PERSISTENT or TEMPORARY indicates whether persistence is ensured or not. DATA or UNDO indicates the type of tablespace and stored data.

**Table 6-9** Tablespace attribute of GOLDBLOCKS database

| Attribute            |            | Description                                                                                                                                                                                      |
|----------------------|------------|--------------------------------------------------------------------------------------------------------------------------------------------------------------------------------------------------|
| Persistence          | PERSISTENT | It supports persistence of data stored in a tablespace. (A recovery is required.)                                                                                                                |
|                      | TEMPORARY  | It does not support persistence of data stored in a tablespace.                                                                                                                                  |
| Type of stored data  | DATA       | It stores the user input data.                                                                                                                                                                   |
|                      | UNDO       | It stores data required for MVCC of database.                                                                                                                                                    |
|                      | DICTIONARY | It stores dictionary information for database operation.                                                                                                                                         |
|                      | TEMPORARY  | It stores data for SQL processing.                                                                                                                                                               |
| Type of stored media | DISK       | Pages of the disk tablespace should be read from the disk data file by using the buffer cache. If it is cached, then it is accessible in the buffer cache.                                       |
|                      | MEMORY     | When creating a tablespace, the exclusive shared memory whose size is as same as that of the data file is created. Therefore, the instant access to the desired page is available in the memory. |

## Managing Tablespace

- Creating user tablespace

It creates a new user tablespace. The name of tablespace being used in the database instance should be unique when creating tablespace. A tablespace can have up to 1024 data files. The data file in the memory tablespace can store up to 30 GBytes, and the data file in the disk tablespace can store as much as the disk physically allows. The database can create tablespaces up to 65,535, including system tablespace.

The data file name including the absolute path in the data file should be unique. Use 'REUSE' option to reuse the existing data file which is not being used in database. An extent size of a tablespace is selectable among 64 Kbytes, 128 Kbytes, 256 Kbytes, 512 Kbytes and 1 Mbyte, and the default extent size is 256 Kbytes.

```
gSQL> CREATE TABLESPACE TEST_TBS DATAFILE
      '/goldilocks1/db/TEST_TBS1.dbf' SIZE 20M,
      '/goldilocks2/db/TEST_TBS2.dbf' SIZE 50M,
      '/goldilocks3/db/TEST_TBS3.dbf' SIZE 100M REUSE;
```

Tablespace created.

The following is an example of creating a disk tablespace.

```
gSQL> CREATE DISK TABLESPACE TEST_TBS DATAFILE
      '/goldilocks1/db/TEST_DISK_TBS1.dbf' AUTOEXTEND OFF MAXSIZE 20M,
      '/goldilocks2/db/TEST_DISK_TBS2.dbf' AUTOEXTEND ON NEXT 20M MAXSIZE UNLIMITED REUSE;
Tablespace created.
```

The state can be set to ONLINE/OFFLINE when creating tablespace, and the LOGGING/NOLOGGING property also can be set.

- Dropping tablespace

The tablespace and data file can be dropped when the tablespace is not needed any more. The unused tablespace should be dropped not to waste the resources. It is because once tablespace is created, the added disk data file and memory is created and remains.

```
gSQL> DROP TABLESPACE TEST_TBS;
Tablespace dropped.
```

Dropping the tablespace does not drop its table index in use by default. Therefore, *INCLUDING CONTENTS* option should be used together when dropping tablespace including tables or indexes in use.

```
gSQL> DROP TABLESPACE TEST_TBS;
ERR-42000(16148): tablespace not empty, use INCLUDING CONTENTS option :
drop tablespace TEST_TBS
      *
ERROR at line 1:
gSQL> DROP TABLESPACE TEST_TBS INCLUDING CONTENTS;
Tablespace dropped.
```

Use *AND DATAFILES* option to drop the data files added in the tablespace.

```
gSQL> DROP TABLESPACE TEST_TBS INCLUDING CONTENTS AND DATAFILES;
Tablespace dropped.
```

- Altering tablespace size

Add datafiles to the tablespace or drop datafiles from the tablespace to alter the tablespace size. Add new datafiles to tablespace to spare space when the storing space is not enough during database operation. Or, drop unused datafile from tablespace not to waste the space.

```
gSQL> ALTER TABLESPACE TEST_TBS ADD DATAFILE 'TEST_TBS2.dbf' SIZE 20M;
Tablespace altered.
gSQL> ALTER TABLESPACE TEST_TBS DROP DATAFILE 'TEST_TBS2.dbf';
Tablespace altered.
```

The data file could be dropped from tablespace only when it has never been used since its creation. The data file can not be dropped once it has been used even when all data was dropped.

```
ALTER TABLESPACE TEST_TBS DROP DATAFILE 'TEST_TBS2.dbf';
ERR-42000(14044): datafile not empty
```

- Managing temporary tablespace

Temporary tablespace does not store data file, but it allocates memory of specified size. Create the temporary tablespace as follows.

```
gSQL> CREATE TEMPORARY TABLESPACE TEST_TBS MEMORY 'TEST_TEMP_TBS' SIZE 10M EXTSIZE 256K;
Tablespace created.
```

Add memory to the temporary tablespace as follows.

```
gSQL> ALTER TABLESPACE TEST_TBS ADD MEMORY 'TEST_TBS2' SIZE 10M;
Tablespace altered.
```

Drop the unused memory from the temporary tablespace as follows.

```
gSQL> ALTER TABLESPACE TEST_TBS DROP MEMORY 'TEST_TBS2';
Tablespace altered.
```

Drop the temporary tablespace as follows.

```
gSQL> DROP TABLESPACE TEST_TBS INCLUDING CONTENTS AND DATAFILES;
Tablespace dropped.
```

## Transferring Data File

The data file storage path stored in the database should be modified when altering the datafile storage disk, or directory.

The following is an example to describe how to modify the path when transferring the datafile '/goldilocks1/db/TEST\_TBS1.dbf' in tablespace TEST\_TBS to '/goldilocks4/db/TEST\_TBS1.dbf'.



```
gSQL> ALTER TABLESPACE TEST_TBS RENAME DATAFILE
      '/goldilocks1/db/TEST_TBS1.dbf' TO '/goldilocks4/db/TEST_TBS1.dbf';
Tablespace altered.
```

## Tablespace Information

For more information about the tablespaces created in database, refer to **V\$TABLESPACE**.

```
gSQL> \DESC V$TABLESPACE
COLUMN_NAME      TYPE                IS_NULLABLE
-----
TBS_NAME         CHARACTER VARYING(128) FALSE
TBS_ID          NUMBER              FALSE
TBS_ATTR        CHARACTER VARYING(128) FALSE
IS_LOGGING      BOOLEAN             FALSE
IS_ONLINE       BOOLEAN             FALSE
OFFLINE_STATE   CHARACTER VARYING(32) FALSE
EXTENT_SIZE     NUMBER              FALSE
PAGE_SIZE       NUMBER              FALSE
```

## 6.5 Managing Data File

### Data File Matching

Data file can be corrupted due to disk failure, database defects or human error. If the corrupted data file is used in database, serious problems occurs.

GOLDILOCKS database ensures the matching of the data file using a checksum for each page of the data file. GOLDILOCKS database's page checksum is generated using LSN and CRC value, and it is stored in each page. A user sets the page checksum type using the value in **PAGE\_CHECKSUM\_TYPE**, and uses LSN or the default value.

The page checksum is checked when loading the data file into the memory at database startup. If an error occurs concerning the checksum value, the database can not start up the service.

The following is an example to describe the database startup failure when the datafile TEST\_TBS.dbf in the tablespace TEST\_TBS created by a user is not matching.

```
gSQL> \STARTUP MOUNT
Startup success
gSQL> ALTER SYSTEM OPEN DATABASE;
ERR-HY000(14094): datafile recovery required - datafile(/goldilocks/db/TEST_TBS.dbf) of
tablespace(TEST_TBS) corrupted
```

In case when the data file is not matching, set its tablespace having the data file to *OFFLINE*, or recover the data file to restart the database.

The following describes how to start up the database after setting the tablespace to *OFFLINE*.

```
gSQL> \STARTUP MOUNT
Startup success
gSQL> ALTER SYSTEM OPEN DATABASE;
ERR-HY000(14094): datafile recovery required - datafile(/goldilocks/db/TEST_TBS.dbf) of
tablespace(TEST_TBS) corrupted
gSQL> ALTER TABLESPACE TEST_TBS OFFLINE IMMEDIATE;
Tablespace altered.
gSQL> ALTER SYSTEM OPEN DATABASE;
System altered.
```

Data file full backup or incremental backup should exist when recovering the data file.

The following describes how to recover the data file when backup exists.

```
gSQL> \STARTUP MOUNT
Startup success
gSQL> ALTER SYSTEM OPEN DATABASE;
ERR-HY000(14094): datafile recovery required - datafile(/goldilocks/db/TEST_TBS.dbf) of
tablespace(TEST_TBS) corrupted
gSQL> ALTER DATABASE RECOVER DATAFILE 'TEST_TBS.dbf' CORRUPTION;
Database altered.
gSQL> ALTER SYSTEM OPEN DATABASE;
System altered.
```

## Data File Information

For more information about data files being used in database, refer to **V\$DATAFILE**.

```
gSQL> \DESC V$DATAFILE
COLUMN_NAME      TYPE                                IS_NULLABLE
-----
TBS_NAME         CHARACTER VARYING(128)            FALSE
DATAFILE_NAME    CHARACTER VARYING(1024)          FALSE
CHECKPOINT_LSN   NUMBER                             FALSE
CREATION_TIME    TIMESTAMP(2) WITHOUT TIME ZONE  FALSE
FILE_SIZE        NUMBER                             FALSE
```

## 6.6 Buffer Cache

### Structure of GOLDBLOCKS Buffer Cache

It caches pages required from the disk data file to access index pages and tables stored in the disk tablespaces to the buffer. GOLDBLOCKS allocates the buffer cache as big as the size set in **BUFFER\_CACHE\_SIZE** property, and it retrieves the pages requested from the page cached in the buffer cache by using a hash table as big as the size set in **BUFFER\_HASH\_BUCKETS** property. It increases the touch count whenever accessing to the page. If the available space does not exist in the buffer cache, then it uses LRU strategy which replaces the page whose touch count value is small.

Figure 2 Structure of GOLDBLOCKS buffer cache

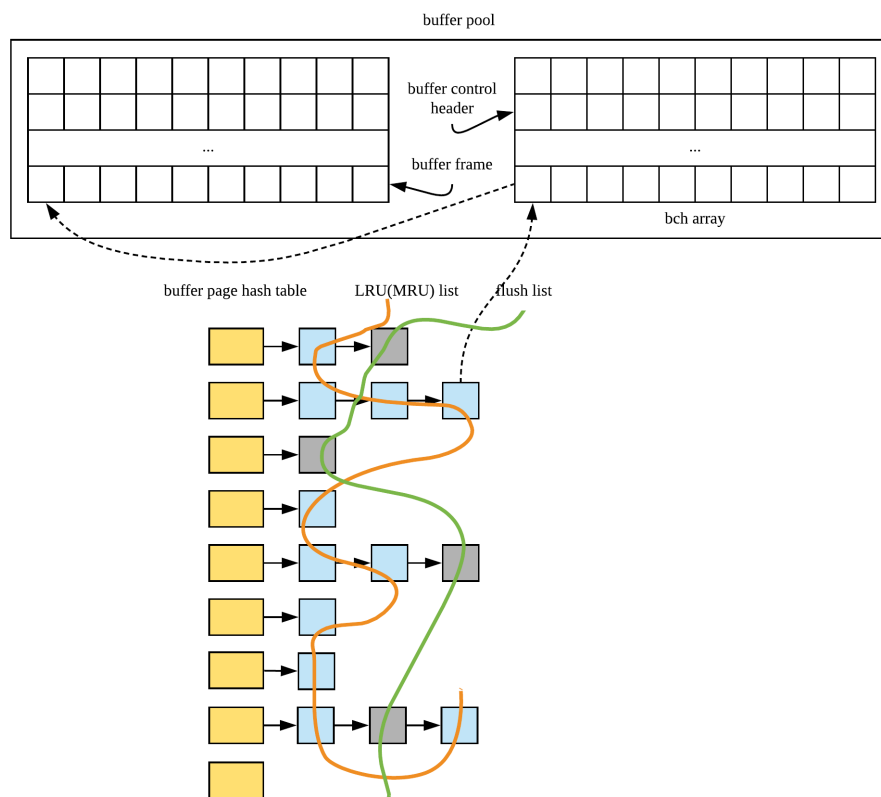

### Buffer Cache List

The followings are lists which are used for the buffer cache in GOLDBLOCKS.

**Table 6-10** Buffer cache list

| List                   | Description                                                                                                  | Property                     |
|------------------------|--------------------------------------------------------------------------------------------------------------|------------------------------|
| Buffer free list       | It is a list of buffer frames which are immediately available.                                               | BUFFER_FREE_LIST_COUNT       |
| Buffer LRU list        | It is a list to retrieve the pages which is reusable based on the touch count.                               | BUFFER_LRU_LIST_COUNT        |
| Buffer flush list      | It is a list of buffer frames to reflect the pages updated to reuse in the buffer LRU list to the data file. | BUFFER_FLUSH_THREADS         |
| Buffer checkpoint list | It is a list of updated page frames which should be flushed to the data file at the time of checkpoint.      | BUFFER_CHECKPOINT_LIST_COUNT |

Page frames which were not used after the system startup are linked to the buffer free list, and used page frames are linked to the buffer LRU list. The page frame updated in the buffer cache is linked to the buffer checkpoint list, but it is not dropped from the buffer LRU list.

After all page frames are used in the buffer free list and a page frame to cache a new page does not exist, then it looks for an available page frame by retrieving the buffer LRU list. The page frame which were updated but not in use is transferred to the buffer flush list at this moment.

A page frame can not be linked redundantly to the buffer free/ LRU/ flush list except for the buffer checkpoint list. In other words, a page frame in the buffer free list can not simultaneously exist in the buffer LRU/ flush list, nor can a page frame in the buffer LRU list exist in the buffer free/ flush list.

The buffer LRU list is divided into hot/ cold area, and if the touch count of the page frame in the cold area is same or larger than the specified value (**BUFFER\_HOT\_REGION\_CRITERIA**), then it is transferred to the hot area. The touch count increases whenever the page frames in the buffer LRU list access, and if all of them belong to the hot area, then the page frame to replace is not available. Therefore, the hot area size is restricted to the **BUFFER\_HOT\_REGION\_PERCENT** property value.

## Page Frame Status

All page frames of the buffer cache have the following status.

**Table 6-11** Buffer frame status

| Status   | Description                                                                      | Page frame access |
|----------|----------------------------------------------------------------------------------|-------------------|
| FREE     | It is the page frame which is not currently used.                                | Inaccessible      |
| PREPARED | It is allocated for the page caching, but is not completely read from the disk.  | Inaccessible      |
| CLEAN    | A page was cached to the buffer cache and the page frame never has been updated. | Accessible        |
| DIRTY    | A page was cached to the buffer cache and the page frame is updated.             | Accessible        |

| Status       | Description                                                                                                         | Page frame access |
|--------------|---------------------------------------------------------------------------------------------------------------------|-------------------|
|              | ed.                                                                                                                 |                   |
| FLUSHING     | A page was cached to the buffer cache and the page frame is updated, and it is being flushed to the disk data file. | Accessible        |
| INCONSISTENT | The page frame status is abnormal in the buffer cache.                                                              | Inaccessible      |

**7.**

---

## **Backup and Recovery of GOLDBLOCKS Database**

This chapter describes GOLDILOCKS database backup and recovery, database ARCHIVELOG mode for the backup and recovery.

## 7.1 ARCHIVELOG Mode

GOLDILOCKS database executes logging using circular log group. A circular log group consists of at least four log groups, and if all log allocated to a log group are run out, then following log group is used. If all created log groups are run out, the first log group is reused. In this case, the new log file is not created but the previously recorded log file is reused.

The previously written logs are lost if a log group is reused in NOARCHIVELOG mode. Therefore, if an administrator does not manage the completed logging group, the completed transactions logs disappears while operating in NOARCHIVELOG mode.

On the other hand, in ARCHIVELOG mode, the system archives log files prior to reusing it when using the following log groups after the completion of recording on log file in a log group. Then the completed logs are permanently preserved unless they are deliberately deleted.

### ARCHIVELOG Mode

Log files should be archived before they are reused. It is because all log files after backup moment is required for the recovery using backup, and the backup could be needed anytime. Therefore, the backup is supported only in ARCHIVELOG mode.

The service can be interrupted in busy system due to archiving when operating in ARCHIVELOG mode. Also, an additional space is needed to store files.

### NOARCHIVELOG Mode

Backup is not supported in NOARCHIVELOG mode, because it can not be determined if the log files of before reusing exist.

However, system does not archive log files. Therefore, the interruption due to an archiving at checkpoint when bulk logs are continuously being recorded does not occur. Also, it does not need a storage space for archive log files.

NOARCHIVELOG mode is set by the 'ARCHIVELOG\_MODE' property value when creating database. Data



base is created in NOARCHIVELOG mode if the 'ARCHIVELOG\_MODE' value is 0, and it is created in ARCHIVELOG mode when the 'ARCHIVELOG\_MODE' value is 1. This property is valid only when creating database, and it is not referenced when operating database.

Execute the following syntax in mount phase of GOLDILOCKS database startup level to change ARCHIVELOG mode during database operation.

```
gSQL> ALTER DATABASE ARCHIVELOG;
```

```
Database altered.
```

```
gSQL> ALTER DATABASE NOARCHIVELOG;
```

```
Database altered.
```

Enquire *ARCHIVELOG\_MODE* of *V\$ARCHIVELOG* which is the performance view to retrieve archive log mode set in database.

```
gSQL> SELECT ARCHIVELOG_MODE FROM V$ARCHIVELOG;
```

```
ARCHIVELOG_MODE
```

```
-----
```

```
NOARCHIVELOG
```

```
1 row selected.
```

## 7.2 Backup and Recovery

### Backup

#### The Purpose of Backup and Recovery

Database can protect and recover data when various failures or data loss occurs. There are many reasons for failures. The duplicated copy is required especially when the database is physically corrupted or damaged by disaster, and this is called as backup.

When database service is not available due to various failures, it becomes available again by using current database or backup, and this is called as recovery. The restart recovery is to recover by using the current database. The media recovery is to recover by using the backup. GOLDILOCKS automatically or manually performs the media recovery to recover the backup data file, then recover and restarts by the restart recovery.

### Backup

Database backup is divided into physical backup and logical backup. Generally, backup means making copy of data files online. This chapter describes the online physical backup.

**Table 7-1** Database backup type

| Backup type     | Backup form   | Database state | Description                                                                                                      |
|-----------------|---------------|----------------|------------------------------------------------------------------------------------------------------------------|
| Physical backup | Cold backup   | Offline        | Creating the copy of data file<br>Stopping service to execute backup                                             |
|                 | Hot backup    | Online         | Creating the copy of data file<br>Executing backup during service operation<br>Available only in ARCHIVELOG mode |
| Logical backup  | Export backup | Online         | Backup/recovery in table unit<br>Exporting regardless of HW/OS                                                   |

GOLDILOCKS uses data files and control files for executing service, and they should be recovered when they were corrupted from a failure. A control file is created when creating database, and stores necessary information to operate database. A data file stores actual data, and they are data files in system tablespace created when database is created and datafiles in user made tablespace. Use backup files for recovery when some of those control files or data files are corrupted.

In other words, control files and data files should be backed up for recovery. In order to do so, GOLDILOCKS supports control file backup, database backup, and tablespace backup.

Depending on the backup method, it is divided into full backups and incremental backups. Full backup co

copies data files in time of backup, and an incremental backup copies only modified parts since the previous backup. The full backup copies data files, so the copy is as big as the data file is created everytime of backup. Therefore, it consumes the storage space as much as the size of database or tablespace.

On the other hand, the size of the incremental backup is relatively small because it copies only the modified part after the previous backup.

**Table 7-2** Full backup vs. incremental backup

| Item          | Full backup                                                                                                                                                                                                                                                                         | Incremental backup                                                                                                                                                                                                                                                                                                   |
|---------------|-------------------------------------------------------------------------------------------------------------------------------------------------------------------------------------------------------------------------------------------------------------------------------------|----------------------------------------------------------------------------------------------------------------------------------------------------------------------------------------------------------------------------------------------------------------------------------------------------------------------|
| Backup object | <ul style="list-style-type: none"> <li>Database: Entire data file which is being used by database</li> <li>Tablespace: Data files in database's specific tablespace</li> </ul>                                                                                                      |                                                                                                                                                                                                                                                                                                                      |
| Description   | <ul style="list-style-type: none"> <li>Backup entire data file which is being used by database or tablespace</li> <li>Creating a backup file per a data file</li> <li>Restoring the required data file after failure by using appropriate backup method, then recover it</li> </ul> | <ul style="list-style-type: none"> <li>Backup the modified part of the data file being used by database or tablespace after the previous backup</li> <li>Creating an incremental backup file in which the modified part is recorded</li> <li>Recovery by using multiple incremental backups after failure</li> </ul> |

## Full Backup

Use full backup to execute database backup and tablespace backup. Database backup is to backup control files and data files.

## Control File Backup

Backup the control file as follows. Specify the backup control file name including the absolute path, or specify the backup control file name only. If only the backup control file name is specified, the backup file is created in the path set in the 'LOG\_DIR' property.

```
gSQL> ALTER DATABASE BACKUP CONTROLFILE TO '/goldilocks_data/backup/backup.ctl';
Database altered.
```

## Database Backup

Database backup can backup entire data file being used in database. When backup data file, recording on the file should be prevented while copying the data file. If the file is used during copying, the data file becomes inconsistent, and even worse it will be inconsistent within a page. Set the database to the state which enables backup to prevent those inconsistencies.

```
gSQL> ALTER DATABASE BEGIN BACKUP;
Database altered.
```

Use operating system's file copy feature to create the copy of data file on database backup enabled state. Then set it as follows, then the database backup is completed, and it is writable.

```
gSQL> ALTER DATABASE END BACKUP;  
Database altered.
```

## Tablespace Backup

Tablespace backup can backup data files being used by a specified tablespace. Set it to backup enabled state by using the tablespace name (`tablespace_name`) as follows for the same reason of database backup.

```
gSQL> ALTER TABLESPACE TEST_TBS BEGIN BACKUP;  
Tablespace altered.
```

Use operating system's file copy feature to create the copy of tablespace's data file on tablespace backup enabled state. Then, complete the tablespace backup as follows.

```
gSQL> ALTER TABLESPACE TEST_TBS END BACKUP;  
Tablespace altered.
```

## Incremental Backup

An incremental backup supports database unit backup and tablespace unit as same as full backup. An incremental backup does not backup control files separately, but the control file is backed up together when executing the database incremental backup.

GOLDILOCKS supports incremental level from 0 to 4 for an incremental backup. When an incremental backup is executed for the first time, the level should be set to 0, and backup the entire data file. Set the incremental backup level to 1 or higher to back up only the modified parts since the last backup when executing the incremental backup later.

The given level of incremental backup searches for the time when the same level or lower level was executed. Then, it backs up only the modified parts after the previous backup.

For example, after performing level 0 backup, level 2 backup(1) backs up only the modified parts after the level 0 backup, and level 2 backup(2) backs up the modified part after the level 2(1) backup. In the same way, level 2 backup(3), (4), (5), (6) backs up the modified part after the level 2 backup. The level 1 backup which was executed lastly backs up all modified parts after the level 0 backup.

Figure 1 Incremental backup

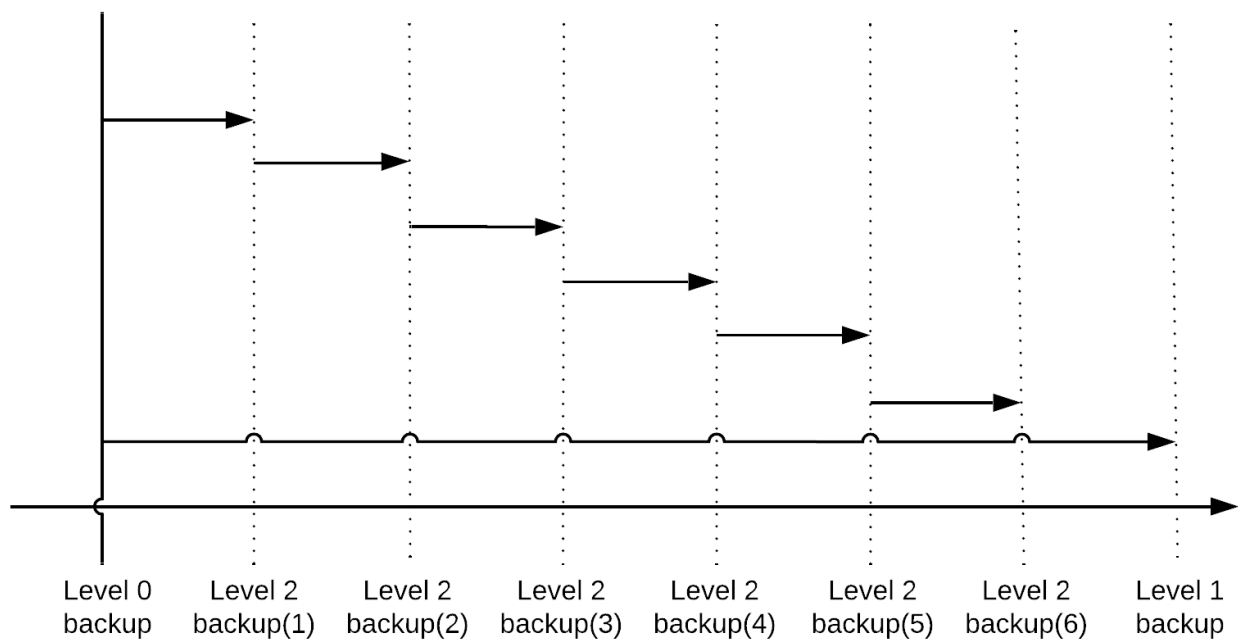

## Database Incremental Backup

Execute an incremental backup on the entire data file of database as follows. At first, the entire data file of database is backed up at level 0.

```
gSQL> ALTER DATABASE BACKUP INCREMENTAL LEVEL 0;
Database altered.
```

And then, the modified part after level 0 is backed up at level 1.

```
gSQL> ALTER DATABASE BACKUP INCREMENTAL LEVEL 1;
Database altered.
```

## Tablespace Incremental Backup

At first, the entire data file of tablespace is backed up at level 0 as follows in the same way as the database backup.

```
gSQL> ALTER TABLESPACE TEST_TBS BACKUP INCREMENTAL LEVEL 0;
Tablespace altered.
```

And then, the modified part after level 0 is backed up at level 1.

```
gSQL> ALTER TABLESPACE TEST_TBS BACKUP INCREMENTAL LEVEL 1;
Tablespace altered.
```

## Change Tracking

It should scan the entire data file to figure whether any page is updated after the previous backup to perform the incremental backup for the disk tablespace. Therefore, if the data file size is big, then the incremental backup takes a long time even when the number of actually updated pages is small because it should scan the entire data file.

Change tracking stores only updated pages after the incremental backup, then performs the next incremental backup by selecting updated pages only without full scan. Therefore, the backup time is decreased.

However, if most of the pages in the data file were updated, then it should backup the most part of the data file, so the change tracking is not efficient. The change tracking is available when the database is in ARCHIVELOG mode only, but it is not available in NOARCHIVELOG mode.

The following is an example of enable/disable the change tracking in the database.

```
gSQL> ALTER DATABASE ENABLE CHANGE TRACKING;  
Database altered.  
gSQL> ALTER DATABASE DISABLE CHANGE TRACKING;  
Database altered.
```

If the change tracking is enabled, then it creates the tracking file and the shared memory. The structure of the change tracking file and that of the shared memory are same. It consists of blocks storing update flags for pages bound in a number specified in **CHANGE\_TRACKING\_EXTENT\_SIZE** property.

The update flags are initialized when the incremental backup is performed for the first time after the change tracking is enabled. If a page is updated, then it is recorded on the flag of the page, so it scans only the pages which were recorded on the update flags in the change tracking file and backs up only updated pages at the next incremental backup.

If the change tracking is enabled, then it creates a file in the location specified in **CHANGE\_TRACKING\_FILE** property. If the file name and storing location for change tracking are specified when enabling it, then the file is created in the specified location. If the storing location is not specified, then the change tracking file is created in the location specified in **BACKUP\_DIR** property.

```
gSQL> ALTER DATABASE ENABLE CHANGE TRACKING USING FILE '/tmp/change_tracking.ctf';  
Database altered.
```

The change tracking file size is 10 M, and it increases by 10 M when the change tracking file is full due to the increased number of disk data files.

## Recovery

Database guarantees data consistency by executing recovery when a failure occurs or database is corrupted.

The types of database failure are as follows.

**Table 7-3** Database failure type

| Failure type        | Causes and symptoms                                                                             | Solution                  |
|---------------------|-------------------------------------------------------------------------------------------------|---------------------------|
| Transaction failure | Transaction failure and deadlock due to the logical error (bad input, overflow, data not found) | Abort transaction         |
| System crash        | Corruption of volatile storage device due to an abnormal termination (blackout) of DBMS or OS   | Restart recovery          |
| Media failure       | Corruption of non-volatile storage device                                                       | Restore, restart recovery |

Abort the executing transactions, rollback all database updates and release obtained lock items to solve transaction failure.

Database processes are abnormally terminated at system crash, so the recent information stored in volatile storage are not reflected in the non-volatile storage, and they are lost. Startup database, and recover the database to the state when it was consistent before abnormal termination. This process is called as restart recovery. To recover the database, the restart recovery uses control files, data files, and log files which were used by database before the failure.

The recovery using database file before failure is not possible if non-volatile storage device is corrupted. It is because control files, datafiles and log files are corrupted so that they can not be used for recovery. In this case, recover the database file by using previously archived backup files and log files, then execute the recovery.

GOLDILOCKS supports both the complete recovery and the incomplete recovery. The complete recovery recovers the datafile to the latest and consistent state by using the log file. The complete recovery targets database, tablespace and data file. For the tablespace and data file, the complete recovery is available for the offline tablespace even during the database service. The complete recovery is divided into the automatic recovery and the manual recovery. The automatic recovery is performed when restarting the database, and the manual recovery uses the recovery statement supported by GOLDILOCKS.

The incomplete recovery is available only for the database, and it recovers to the consistent state of a specific point. The incomplete recovery is performed only manually. It incompletely recovers at once up to the specific point, or it performs the user selective incomplete recovery. The user selective incomplete recovery is a method of which a user selects a log file available to recover and recovers up to that user selected log file.

If both the complete recovery and the incomplete recovery is required, then use redo log and archive log f

iles.

**Table 7-4** Database recovery

| Recovery            | Target                         | Description                                                                                                                                                                                                           |
|---------------------|--------------------------------|-----------------------------------------------------------------------------------------------------------------------------------------------------------------------------------------------------------------------|
| Complete recovery   | Database, tablespace, datafile | <ul style="list-style-type: none"> <li>• Automatic recovery (Recovers at the restart)</li> <li>• Manual recovery (Manually recovers the database, tablespace and data file.)</li> </ul>                               |
| Incomplete recovery | Database                       | <ul style="list-style-type: none"> <li>• Manual recovery only               <ul style="list-style-type: none"> <li>◦ Incomplete recovery at once</li> <li>◦ User selective incomplete recovery</li> </ul> </li> </ul> |

## Automatic Recovery

The automatic recovery is executed when restarting after a normal or abnormal termination of database. It uses the control files, data files and log files which were used just before the termination.

Especially when the latest database file is corrupted, the backed up database file is recovered and the automatic recovery is executed by using the archive log file.

The recovery is executed in three phases, and they are analysis, redo and undo.

### Analysis

Two operations are executed in analysis phase.

First, it searches for the first log to perform the restart recovery. For that, it refers to the most recently executed checkpoint log, and looks for the most recent checkpoint log from the log information recorded in control file.

Second, it initialize the transaction table of the system. It uses transaction information which was executed at checkpoint written on checkpoint log to initialize system transaction table.

### Restart Redo

All logs, from the first log obtained in the analysis phase for restart recovery to the last log recorded in the redo log files, execute restart redo. The transaction table is updated when a transaction is completed or a new transaction is started during this process.

### Restart Undo

After restart redo is completed, it performs the transaction rollback by performing undo all incomplete transactions remained in the transaction table.



## Recovery Using Backup

If control files, data files and log files are corrupted or does not exist, the recovery should be performed after it is recovered by using the backup file. It is complicated to find the log on which the recovery starts when performing the recovery by using the backed up control file or the data file.

### Analysis for Recovery Using Backup

In analysis phase for the recovery using backup, like as the automatic recovery, it searches for the first log for recovery and initializes the transaction table. It searches for the oldest LSN among the checkpoint LSN recorded in all the data file's file header, then selects the minimum value by comparing it with checkpoint LSN recorded in control file to find the first log for recovery.

The checkpoint LSN recorded in data file header stores the checkpointed LSN of the corresponding data file. Therefore, when using the backup datafile, select the oldest checkpoint LSN, and then select the minimum value comparing to the checkpoint LSN in the control file, then the minimum checkpoint LSN for the recovery is determined.

**Figure 2** Procedure to determine the minimum checkpoint LSN for the recovery

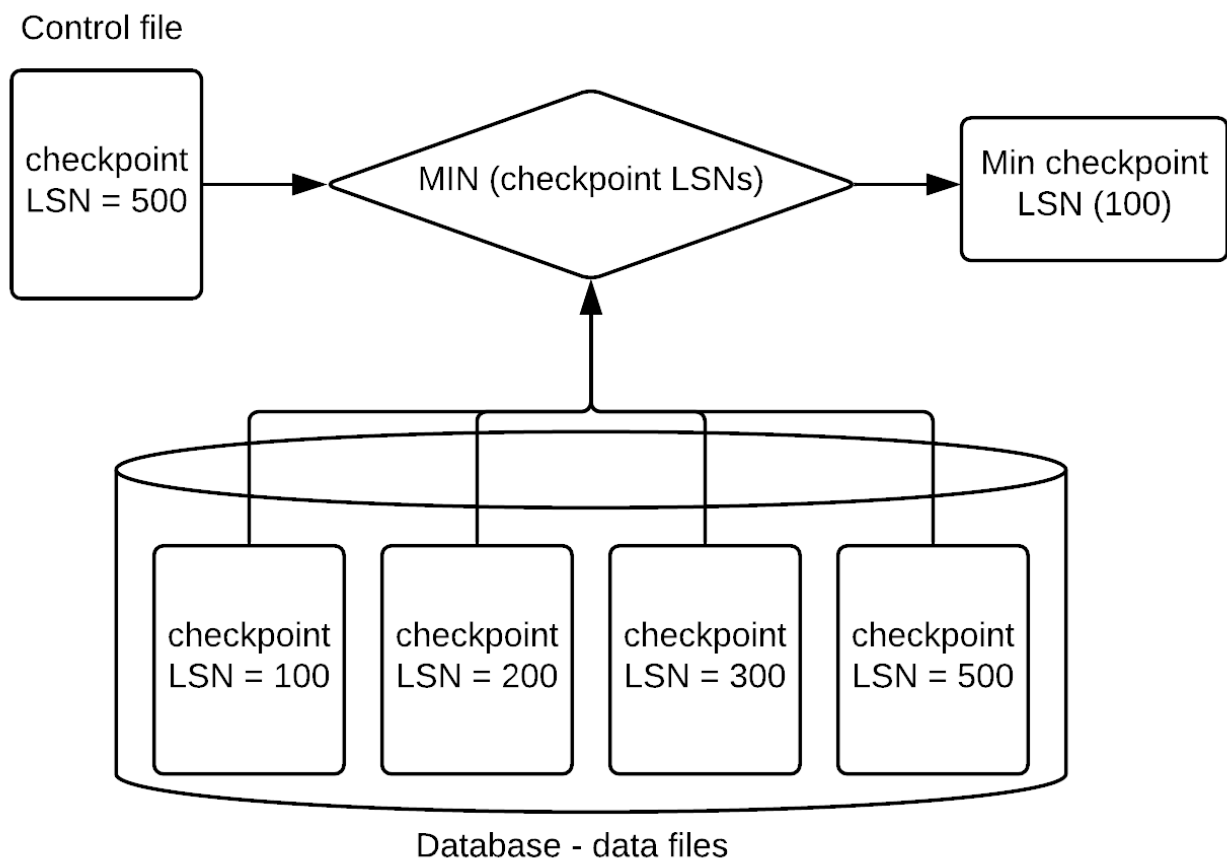

## Recovery Using Archive Log Files

The recovery using archive log files uses not only redo log files but also archive log files, when the minimum checkpoint LSN defined for the recovery is in an archive log file. The recovery using the backup is executed in a unit of database, tablespace and data file. Database recovery is executed only on MOUNT phase, and the recovery in tablespace and data file unit is executed on MOUNT phase or OPEN phase.

- Restoring the backup data files

Restoring data files is executed by using the full backup or the incremental backup. A user directly executes the full backup by using operating system's file copy command to restore data. On the other hand, the incremental backup is executed by using restoring syntax of GOLDBLOCKS. The tablespace should be OFFLINE to restore data files on OPEN phase.

The followings describe how to restore data files using incremental backup.

```
gSQL> ALTER DATABASE RESTORE;
```

```
Database altered.
```

```
gSQL> ALTER DATABASE RESTORE TABLESPACE TEST_TBS;
```

```
Database altered.
```

- Manual recovery after restoring data files

The followings describe how to execute recovery using the syntax of recovery after restoring data files.

```
gSQL> ALTER DATABASE RECOVER;
```

```
Database altered.
```

```
gSQL> ALTER DATABASE RECOVER TABLESPACE TEST_TBS;
```

```
Database altered.
```

## Incomplete Recovery

If the restart recovery is not available due to a user mistake during operation, corrupted control files, or corrupted redo log files and archive log files nor can the recovery restore consistency of database, then execute the incomplete recovery. The incomplete recovery restores data only until the point-in-time.

The followings are when the incomplete recovery is required.

## Corrupted Control File

Control files are multiplexed, so they can be recovered using uncorrupted files if not all of the multiplexed files are corrupted.

However, if all control files are corrupted, recovery should be executed using the backup control files. In this case, the complete recovery is impossible because the log information of the control files can be changed. The recovery restores only until point-in-time.

## Restoring Backup Control File

When control files are corrupted, copy other multiplexed control files to keep control files up-to-date.

However, when all multiplexed control files are corrupted, restore the backup control files, then perform the recovery. The log information which is changed after the backup can not be recovered when executing recovery using the backup data files.

## Corrupted Redo Log File

GOLDILOCKS consists redo log files with several log members in a log group to prevent log file corruption. However, if all log members in a log group are corrupted, it can not be recovered using redo log file. In this case, an incomplete recovery should be executed until uncorrupted log file.

## Corrupted Archive Log File

In recovery, if archive log file is corrupted, then incomplete recovery should be executed until uncorrupted log file. The process is as same as when redo log file is corrupted.

## User's Mistake

When a user dropped an important table by mistake, or inserted, updated, deleted wrong data, it should be recovered back to the point before the mistake.

## Incomplete Recovery of GOLDILOCKS Database

GOLDILOCKS supports two types of incomplete recovery. One of the recovery is executed until the point which an operator specified. The other recovery is executed in log file unit interactively between an operator and system.

The incomplete recovery until a specified point can specify the point-in-time by using a specified log's LSN, specified time, or a specified SCN.

Incomplete recovery is executed for the entire database only on MOUNT phase. Incomplete recovery in the specific tablespace unit is not supported due to the database consistency problem.

- Incomplete recovery until specified LSN

It searches for log which will complete the incomplete recovery, then executes the recovery until the log's LSN.

The following is an example of executing the incomplete recovery until log LSN 1000.

```
gSQL> ALTER DATABASE RECOVER UNTIL CHANGE 1000;
Database altered;
gSQL> ALTER DATABASE RECOVER UNTIL CHANGE LSN 1000;
Database altered;
```

- Incomplete recovery until specified SCN

It searches for SCN which will complete the incomplete recovery, then executes the recovery until the log's SCN.

The following is an example of executing the incomplete recovery until SCN 300.

```
gSQL> ALTER DATABASE RECOVER UNTIL CHANGE SCN 300;
Database altered;
```



SCN is not sequentially recorded so even when the incomplete recovery is executed until SCN 300, it may be recovered beyond SCN 300. The following is an example of the recovery when SCN is reversed.

Log: --- LSN 90 (SCN 3) -- LSN 91 (SCN 5) -- LSN 92 (SCN 4)

```
gSQL> ALTER DATABASE RECOVER UNTIL CHANGE SCN 3;
→ It is recovered until LSN 90.
```

```
gSQL> ALTER DATABASE RECOVER UNTIL CHANGE SCN 4;
→ It is recovered until LSN 92. (It is recovered until LSN 92 in which SCN 4 is.)
```

```
gSQL> ALTER DATABASE RECOVER UNTIL CHANGE SCN 5;
→ It is recovered until LSN 92. (Both SCN 4, SCN 5 are arbitrarily recovered until SCN5)
```

- Incomplete recovery until specified time

It searches for the time which will complete the incomplete recovery, then executes the recovery until the specified time.

The following is an example of executing the incomplete recovery until '2017-05-18 16:10:10.000000'.

```
gSQL> ALTER DATABASE RECOVER UNTIL TIME '2017-05-18 16:10:10.000000';
Database altered;
```

- Interactive incomplete recovery

If the log file is corrupted, it executes the recovery until just before the corrupted log file. For that, GOLDILOCKS suggests an operator the required log files, and the operator executes the incomplete recovery by using the GOLDILOCKS' recommended log file or a new log file.

The following is an example of executing the interactive incomplete recovery of GOLDILOCKS. GOLDILOCKS suggests log files required for the recovery when executing BEGIN for the incomplete recovery. The operator executes the incomplete recovery by using the GOLDILOCKS' recommended log file, or may describe the log file for the recovery.

```
gSQL> ALTER DATABASE BEGIN INCOMPLETE RECOVERY;
ERR-01000(14104): Warning: suggestion '/goldilocks/archive_log/archive_0.log'
ERR-01000(14103): Warning: media recovery needs a logfile including log (Lsn 139992)
Database altered.
gSQL> ALTER DATABASE RECOVER AUTOMATICALLY;
ERR-01000(14104): Warning: suggestion '/goldilocks/archive_log/archive_1.log'
ERR-01000(14103): Warning: media recovery needs a logfile including log (Lsn 144143)
Database altered.
gSQL> ALTER DATABASE END INCOMPLETE RECOVERY;
Database altered.
```

## Restarting Database after Incomplete Recovery

After the incomplete recovery is completed, a user can not restart database in a normal way. It is because the recovered GOLDILOCKS database by the incomplete recovery has nothing to do with the current redo log files. A user should reset the redo log file to restart database because database is at the previous point, and the current redo log file is about the log after then. Use *RESETLOGS* option when restarting GOLDILOCKS database after the incomplete recovery.

```
gSQL> ALTER SYSTEM OPEN DATABASE;
ERR-HY000(14083): must use RESETLOGS option for database open
gSQL> ALTER SYSTEM OPEN DATABASE RESETLOGS;
System altered.
```

## Cautions for Incomplete Recovery

Incomplete recovery is executed until the specific point to create consistent database, but it is not easy to find the specific point. All redo log files are reset after the incomplete recovery. Therefore, all the control files, data files, redo log files in database should be backed up offline before the incomplete recovery. Then the incomplete recovery should be executed several times to find the correct point.

Archive log files are needed during the incomplete recovery. However, the newly recovered database is different from the previous database, so drop the archive redo log file created by the previous database.

## Recovery Examples

### Corrupted Control File

GOLDILOCKS database control files store the important information about the physical structure of database and the database consistency. If it is corrupted or dropped by mistake, the database can not be operated.

GOLDILOCKS database multiplexes at least 2 up to 8 control files. If there is at least one valid control file, the remaining control files are restored, then the database can be restarted.

#### When a valid multiplexed control file exists

If the multiplexed control file `'/goldilocks_data/wal/control_1.ctl'` is corrupted, restarting database fails as follows.

```
gSQL> \STARTUP
ERR-HY000(14097): control file is corrupted - '/goldilocks_data/wal/control_1.ctl'
```

Copy the valid control file `/goldilocks_data/wal/control_0.ctl` to `/goldilocks_data/wal/control_1.ctl`, and drop the shared memory which failed to restart. Then restart the database.

```
$ cp /goldilocks_data/wal/control_0.ctl /goldilocks_data/wal/control_1.ctl
gSQL> \SHUTDOWN
Shutdown success
gSQL> \STARTUP
Startup success
```

#### When all multiplexed control files are corrupted

If all multiplexed control files are corrupted, a user can restart the database using backup control files after incomplete recovery. The database's physical structure can be changed after backing up control files. Therefore, the incomplete recovery should be executed when restoring control files using backup control files. Archive log files and redo log files still exist even after incomplete recovery. Therefore, an administrator executes GOLDILOCKS interactive incomplete recovery to manually restore until 'CURRENT' state redo log file.

The backup control file can be copied to multiplexed control files by operating system's file copy feature, or they can be restored by GOLDILOCKS database's recovery feature as follows. The control file recovery can be executed only in NOMOUNT phase of GOLDILOCKS multilevel startup.

```
gSQL> \STARTUP NOMOUNT
Startup success
gSQL> ALTER DATABASE RESTORE CONTROLFILE FROM '/goldilocks_data/backup/backup.ctl';
Database altered.
```

After restoring the backup control files, execute the incomplete recovery in MOUNT phase as follows.

```
gSQL> ALTER SYSTEM MOUNT DATABASE;
System altered.
gSQL> ALTER DATABASE BEGIN INCOMPLETE RECOVERY;
ERR-01000(14104): Warning: suggestion '/goldilocks/archive_log/archive_0.log'
ERR-01000(14103): Warning: media recovery needs a logfile including log (Lsn 137499)
Database altered.
gSQL> ALTER DATABASE RECOVER AUTOMATICALLY;
ERR-01000(14104): Warning: suggestion '/goldilocks/archive_log/archive_1.log'
ERR-01000(14103): Warning: media recovery needs a logfile including log (Lsn 137667)
Database altered.
gSQL> ALTER DATABASE RECOVER '/goldilocks/wal/redo_1_0.log';
ERR-01000(14104): Warning: suggestion '/goldilocks/archive_log/archive_2.log'
ERR-01000(14103): Warning: media recovery needs a logfile including log (Lsn 137672)
Database altered.
gSQL> ALTER DATABASE END INCOMPLETE RECOVERY;
Database altered.
gSQL> ALTER SYSTEM OPEN DATABASE RESETLOGS;
System altered.
```

## Corrupted Data File

If a data file is corrupted or dropped, the complete recovery is executed by using the backup data files. The full backup restores the data files by copying the backup files, and the incremental backup restores the data files by using the GOLDILOCKS' restoring syntax.

The restoration and recovery of data files are executed in database unit or in tablespace unit. It can also be executed in the tablespace unit of the corresponding data file. The recovery in tablespace unit can be executed in MOUNT phase or OPEN phase. The tablespace should be in OFFLINE state to restore and recover data files on OPEN phase.

- Recovering the corrupted data files using full backup in MOUNT phase

Execute the complete recovery after copying the backup data file */goldilocks/backup/test.dbf* to */goldilocks/db/test.dbf*.

```
$ cp /goldilocks/backup/test.dbf /goldilocks/db/test.dbf
gSQL> \STARTUP MOUNT
System altered.
gSQL> ALTER DATABASE RECOVER;
Database altered.
gSQL> ALTER SYSTEM OPEN DATABASE;
```

System altered.

- Recovering the corrupted data files using full backup in OPEN phase

```
gSQL> SELECT IS_ONLINE FROM V$TABLESPACE WHERE TBS_NAME = 'TEST_TBS';
IS_ONLINE
-----
FALSE
1 row selected.
$ cp /goldilocks/backup/test.dbf /goldilocks/db/test.dbf
gSQL> ALTER DATABASE RECOVER TABLESPACE TEST_TBS;
Database altered.
gSQL> ALTER TABLESPACE TEST_TBS ONLINE;
Tablespace altered.
```

- Recovering the corrupted data files using incremental backup in MOUNT phase

```
gSQL> \STARTUP MOUNT
System altered.
gSQL> ALTER DATABASE RESTORE;
Database altered.
gSQL> ALTER SYSTEM OPEN DATABASE;
System altered.
```

- Recovering the corrupted data files using incremental backup in OPEN phase

```
gSQL> SELECT IS_ONLINE FROM V$TABLESPACE WHERE TBS_NAME = 'TEST_TBS';
IS_ONLINE
-----
FALSE
1 row selected.
gSQL> ALTER DATABASE RESTORE TABLESPACE TEST_TBS;
Database altered.
gSQL> ALTER TABLESPACE TEST_TBS ONLINE;
Tablespace altered.
```

## User's Mistake (Table Dropping or Wrong Insert/drop/update)

GOLDILOCKS database supports DDL rollback of table and index if the table *TEST* is dropped by mistake. Namely, a user can rollback to cancel the table dropping instead of committing as follows even if a user dropped the table.



```

gSQL> DROP TABLE TEST;
Table dropped.
gSQL> ROLLBACK;
Rollback complete.
gSQL> \DESC TEST
COLUMN_NAME TYPE          IS_NULLABLE
-----
I1          NUMBER(10,0) TRUE
I2          CHARACTER(10) TRUE
gSQL> DROP TABLE TEST;
Table dropped.
gSQL> COMMIT;
Commit complete.
gSQL> \DESC TEST
ERR-42000(16040): table or view does not exist :
SELECT * FROM TEST WHERE 1 = 0
          *
ERROR at line 1:

```

If table dropping is committed it can not be rolled back. Therefore, execute GOLDILOCKS incomplete recovery to recover until the specific point of the database using backup. Then, the data is recovered until the time before the table dropping. Restart the database after that.

The backup file at the point before the table dropping is used to restore the table in incomplete media recovery. The correct point can be found, as described above, by repeating the recovery several times to find the time of table dropped. At that time, the gdump tool is used to dump the log file and analyze it.

Assuming LSN is 1000 at the time after table dropping, the incomplete recovery is executed as follows.

```

gSQL> \STARTUP MOUNT
System altered.
gSQL> ALTER DATABASE RECOVER UNTIL CHANGE 1000;
Database altered.
gSQL> ALTER SYSTEM OPEN DATABASE RESETLOGS;
System altered
gSQL> \DESC TEST
COLUMN_NAME TYPE          IS_NULLABLE
-----
I1          NUMBER(10,0) TRUE
I2          CHARACTER(10) TRUE

```

## Corrupted Log File (Archive File, Redo Log File)

- Corrupted archive log file during recovery

Assume that the data files are corrupted and a user are executing recovery using the backup data files. Also, assume that the specific archive log file is corrupted during the recovery so that the recovery can not be completed.

For example, there are archive log files such as 'archive\_0.log', 'archive\_1.log', 'archive\_2.log', 'archive\_3.log'. An 'archive\_3.log' is corrupted, and the recovery can not be executed. In this case, incomplete recovery is executed until 'archive\_2.log', and the database is restarted.

```
gSQL> \STARTUP MOUNT
System altered
gSQL> ALTER DATABASE BEGIN INCOMPLETE RECOVERY;
ERR-01000(14104): Warning: suggestion '/goldilocks/archive_log/archive_0.log'
ERR-01000(14103): Warning: media recovery needs a logfile including log (Lsn 139992)
Database altered.
gSQL> ALTER DATABASE RECOVER AUTOMATICALLY;
ERR-01000(14104): Warning: suggestion '/goldilocks/archive_log/archive_3.log'
ERR-01000(14103): Warning: media recovery needs a logfile including log (Lsn 194143)
Database altered.
gSQL> ALTER DATABASE END INCOMPLETE RECOVERY;
Database altered.
gSQL> ALTER SYSTEM OPEN DATABASE RESETLOGS;
System altered
```

- Corrupted redo log file

Assume that a failure occurs when operating database so the CURRENT log group in which logs are flushed is corrupted.

For example, when an abnormal termination occurs in the state of the following log groups, the manual recovery is executed and completes the incomplete recovery. It is because the log group 3, 0 is not archived yet.

**Table 7-5** Log group state

| Log group   | Log group state | Log file sequence no. | Prev last LSN |
|-------------|-----------------|-----------------------|---------------|
| Log group 0 | ACTIVE          | 8                     | 80000         |
| Log group 1 | CURRENT         | 9                     | 90000         |
| Log group 2 | INACTIVE        | 6                     | 60000         |
| Log group 3 | ACTIVE          | 7                     | 70000         |

```

gSQL> \STARTUP MOUNT
System altered
gSQL> ALTER DATABASE BEGIN INCOMPLETE RECOVERY;
ERR-01000(14104): Warning: suggestion '/goldilocks/archive_log/archive_0.log'
ERR-01000(14103): Warning: media recovery needs a logfile including log (Lsn 1000)
Database altered.
gSQL> ALTER DATABASE RECOVER AUTOMATICALLY;
ERR-01000(14104): Warning: suggestion '/goldilocks/archive_log/archive_7.log'
ERR-01000(14103): Warning: media recovery needs a logfile including log (Lsn 70001)
Database altered.
gSQL> ALTER DATABASE RECOVER '/goldilocks/wal/redo_3_0.log';
ERR-01000(14104): Warning: suggestion '/goldilocks/archive_log/archive_8.log'
ERR-01000(14103): Warning: media recovery needs a logfile including log (Lsn 80001)
Database altered.
gSQL> ALTER DATABASE RECOVER '/goldilocks/wal/redo_0_0.log';
ERR-01000(14104): Warning: suggestion '/goldilocks/archive_log/archive_9.log'
ERR-01000(14103): Warning: media recovery needs a logfile including log (Lsn 90001)
Database altered.
gSQL> ALTER DATABASE END INCOMPLETE RECOVERY;
Database altered.
gSQL> ALTER SYSTEM OPEN DATABASE RESETLOGS;
System altered

```

## More Recent Datafile Than Log

All tablespaces created in GOLDILOCKS database consists of pages, and each page set the log LSN which was recorded by a transaction having updated that page last is set as the page LSN. Therefore, all page LSNs in the datafile have the same or smaller value than the LSN of the latest log recorded in the redo log file of the log group.

When restarting the database, if a specific page's LSN of the data file has a bigger value than the latest log's LSN, then it corrupts the database consistency and the normal service is not available. GOLDILOCKS database checks the data file and log when restarting so that this abnormal situation does not happen.

If any page whose LSN has bigger value than the latest log's LSN is in the data file, then restarting the database fails as follows.

```

gSQL> \STARTUP
ERR-HY000(14114): exist inconsistent datafiles; need to restore more older backup datafiles or
more recent redo logfiles

```

To solve this problem, restore the backup data file consisting of LSNs smaller than the latest log LSN. Or, restart the database after restoring the log file on which the LSN log bigger than the data file is recorded.

Check the trace file to find the data file to restore.

For example, if the following messages are output on the trace file when restarting fails, then the page whose LSN is '126787' in '/data/db/system\_dic.dbf' data file, and this value is bigger than the latest log LSN of the log file '126652'. Therefore, for the restart, restore the previous backup data file, or restore the log file on which the log LSN same or bigger than '126787' is recorded. Also, if several pages of the data file has a LSN value bigger than the log file LSN, then restore the log file bigger than the maximum value among them to restart and provide the service.

```
[2016-01-15 12:41:14.045679 THREAD(10581,139799401453312)] [INFORMATION]
[STARTUP_SM] the max page lsn '126787' of datafile '/data/db/system_dict.dbf' is more recent
than the latest redo log lsn '126652'.
[2016-01-15 12:41:14.045705 THREAD(10581,139799401453312)] [INFORMATION]
[STARTUP_SM] the max page lsn '126830' of datafile '/data/db/system_undo.dbf' is more recent
than the latest redo log lsn '126652'.
[2016-01-15 12:41:14.045729 THREAD(10581,139799401453312)] [INFORMATION]
[STARTUP_SM] the max page lsn '126829' of datafile '/data/db/test_log.dbf' is more recent than
the latest redo log lsn '126652'.
```

## *in doubt* Transaction Recovery in Cluster Environment

The transactions in the cluster environment are divided into global transaction, domain transaction and local transaction. The global transaction is performed in two or more cluster groups, the domain transaction is performed in a single cluster group and the local transaction is performed in a single cluster member.

The local transaction uses only the local member's log when performing the recovery. The domain transaction uses the local member's log when performing the recovery, and performs the rollback when an abnormal termination occurs without completing the transaction, and performs the synchronization with a group member through the rebalance if needed.

The global transaction uses 2 phase commit protocol to commit. 2 phase commit is performed as follows for GOLDILOCKS global transaction.

- PREPARE phase
  - It transfers PREPARE messages from the driver member to all members, and waits for the respond message.
  - It moves on to COMMIT phase when it receives the respond message of PREPARE from all members, or it rolls back when at least one member fails or does not respond.
- COMMIT phase
  - It transfers COMMIT messages from the driver member to all members, and waits for the respond message.
  - It commits even when a member fails.

If a member is abnormally terminated without recording the commit log on COMMIT phase, it should obtain the state information from other members when restarting. It is because it is unable to know if the global transaction in 'PREPARE' state was committed or rolled back, when restarting.

For that, GOLDLOCKS records the committed global transaction information in transaction record form in MEM\_TRANS\_TBS. Also, when recording a new record in that record, the previous record is recorded in commit.log if needed. Later, the abnormally terminated member performs the restart recovery or the manual recovery by using the log. It performs the recovery by obtaining the transaction COMMIT/ROLLBACK information from members in service when *in doubt* transaction in 'PREPARE' state is remained.



**8.**

---

## **GOLDILOCKS Database Replication**

## 8.1 Overview

This chapter describes CYCLONE, LOGMIRROR and CYFILE.

GOLDBLOCKS supports two types of replication, and they are CYCLONE and LOGMIRROR. CYCLONE replicates transactions using CDC, and LOGMIRROR replicates redo log files in the source database.

CYFILE uses CDC method to store/ record the transaction which was applied to the original database in Comma-Separated Values (CSV) format file.

**Table 8-1** Replication tool

| Tool      | Replication target | Description                                                                                       |
|-----------|--------------------|---------------------------------------------------------------------------------------------------|
| CYCLONE   | Transaction        | It uses CDC method, and replicates the transaction reflected in master, then reflect it to slave. |
| LOGMIRROR | Redo log file      | It identically replicates redo file in master database to slave.                                  |
| CYFILE    | Transaction        | It uses CDC method to store/ record the transaction in CSV format file.                           |

- CYCLONE
  - It uses Change Data Capture (CDC) method to analyze and treat redo log files of the source database, then applies them to a remote database.
  - It supports only asynchronous (async) method because it analyzes contents stored in database's redo log file.
- LOGMIRROR
  - It replicates redo log files stored in the source database to a remote database.
  - It is used to avoid the data loss of CYCLONE which is executed in async method.
- CYFILE
  - It analyzes the redo log file of the database in CDC method, and stores it in CSV format data file.
  - A user can perform the replication by using the corresponding file or perform ETL according to the purpose of the development.



## 8.2 Operating Method

### CYCLONE

For more information about general operating method and option, refer to **CYCLONE**.

### Adding and Deleting Nodes

CYCLONE is performed in a group unit, and it is as same as the replication nodes. Add a group when adding nodes, drop a group when deleting nodes.

#### Examples of Adding Nodes

- Record the group 2 to be added in master configuration file.
  - Set a unique port per each group.
  - The default master configuration file is `$GOLDILOCKS_DATA/conf/cyclone.master.conf`.
  - The following is an example of group 1 node in operation.

```
...
...
GROUP_NAME = Group1
{
    PORT = 21102
    CAPTURE_TABLE =
    (
        testTable1,
        testTable2
    )
}
```

- The following is an example of group 2 node to be added.

```
GROUP_NAME = Group2
{
    PORT = 21103
    CAPTURE_TABLE =
    (
        testTable5,
```

```

        testTable6
    )
}

```

- Record the group 2 to be added in slave configuration file.
  - The port of group 2 should be as same as the port added to the existing master.
  - The default slave configuration file is \$GOLDBLOCKS\_DATA/conf/cyclone.slave.conf.
  - The following is an example of group 1 node in operation.

```

...
...
GROUP_NAME = Group1
{
    PORT = 21102
    APPLY_TABLE =
    (
        testTable1 To testTable3,
        testTable2 To testTable4
    )
}

```

- The following is an example of group 2 node to be added.

```

GROUP_NAME = Group2
{
    PORT = 21103
    APPLY_TABLE =
    (
        testTable5 To testTable7,
        testTable6 To testTable8
    )
}

```

- Execute and check the added group 2 node in the master device as follows.

```

prompt> cyclone --master --start --group Group2
[GROUP2] Startup done as Master.
prompt> cyclone --master --status
=====
|          CYCLONE STATUS - MASTER          |
=====

```

```
GROUP1 Running...
GROUP2 Running...
-----
```

- Execute and check the added group 2 node in the slave device as follows.

```
prompt> cyclone --slave --start --group Group2
[GROUP2] Startup done as Slave.
prompt> cyclone --slave --status
=====
                CYCLONE STATUS - SLAVE
=====
GROUP1 Running...
GROUP2 Running...
-----
```

## Examples of Deleting Nodes

- Terminate the group 2 node to be deleted in the slave device as follows.

```
prompt> cyclone --slave --stop --group Group2
stop done.
prompt> cyclone --slave --status
=====
                CYCLONE STATUS - SLAVE
=====
GROUP1 Running...
-----
```

- Terminate the group 2 node to be deleted in the master device as follows.

```
prompt> cyclone --master --stop --group Group2
stop done.
prompt> cyclone --master --status
=====
                CYCLONE STATUS - MASTER
=====
GROUP1 Running...
-----
```

- Drop the group 2 node to be deleted from the master configuration file.
  - The default master configuration file is \$GOLDILOCKS\_DATA/conf/cyclone.master.conf.

- The following is an example of group 1 node in operation.

```
...
...
GROUP_NAME = Group1
{
    PORT = 21102
    CAPTURE_TABLE =
    (
        testTable1,
        testTable2
    )
}
```

- The following is an example of deleting group 2 node.

```
GROUP_NAME = Group2
{
    PORT = 21103
    CAPTURE_TABLE =
    (
        testTable5,
        testTable6
    )
}
```

- Drop the group 2 node to be deleted from the slave configuration file as follows.
  - The default slave configuration file is `$GOLDBLOCKS_DATA/conf/cyclone.slave.conf`.
  - The following is an example of group 1 node in operation.

```
...
...
GROUP_NAME = Group1
{
    PORT = 21102
    APPLY_TABLE =
    (
        testTable1 To testTable3,
        testTable2 To testTable4
    )
}
```

- The following is an example of deleting group 2 node.

```
GROUP_NAME = Group2
{
  PORT = 21103
  APPLY_TABLE =
  (
    testTable5 To testTable7,
    testTable6 To testTable8
  )
}
```

## Initializing Replication

Initializing replication is executed when existing replication nodes or a group's table gives up execution due to DDL operation. A specific node or entire node can be initialized.

The initializing replication is performed by restarting replication being operated in slave using `--reset` option.

On the other hand, master does not require any operation.

## Examples of Initializing Replication on a Specific Node

- Terminate the group 2 node to be initialized in the slave device as follows.

```
prompt> cyclone --slave --stop --group Group2
stop done.
prompt> cyclone --slave --status
=====
                CYCLONE STATUS - SLAVE
=====
GROUP1 Running...
-----
```

- Restart group 2 node in slave device using `--reset` option.
  - Master device does not require any operation.
  - Replication restarts from the current point.

```
prompt> cyclone --slave --start --reset --group Group2
[GROUP2] Startup done as Slave.
prompt> cyclone --slave --status
=====
```

```

CYCLONE STATUS - SLAVE
=====

```

```

GROUP1 Running...

```

```

GROUP2 Running...
-----

```

## Examples of Initializing Replication of All Nodes

- Terminate all CYCLONE in operation in the slave device as follows.

```

prompt> cyclone --stop --slave

```

- Restart CYCLONE in slave device using --reset option.
  - Master device does not require any operation.
  - Replication starts from the current point.

```

prompt> cyclone --slave --start --reset

```

```

[GROUP1] Startup done as Slave.

```

```

[GROUP2] Startup done as Slave.

```

```

prompt> cyclone --slave --status

```

```

=====
CYCLONE STATUS - SLAVE
=====

```

```

GROUP1 Running...

```

```

GROUP2 Running...
-----

```

## LOGMIRROR

For more information about general operation method and options, refer to **LOGMIRROR**.

### Retrieving LOGMIRROR State

GOLDBLOCKS includes the response waiting procedure of LOGMIRROR when GOLDBLOCKS interworks with LOGMIRROR. If LOGMIRROR is waiting for response, GOLDBLOCKS is also waiting in a blocked state. This state can be retrieved in v\$system\_stat.

```

gSQL> SELECT * FROM V$SYSTEM_STAT WHERE STAT_NAME='LOG_MIRROR_SYNC_STATE';

```

```

STAT_NAME          STAT_VALUE COMMENTS
-----

```

```
LOG_MIRROR_SYNC_STATE      0 logmirror sync state( 0 : sync, 1 : blocked )
1 row selected.
```

If STAT\_VALUE is 0, it is not a standby state but an ordinary state. If STAT\_VALUE is 1, it is a blocked state waiting for a response. To restart GOLDILOCKS service while LOGMIRROR is waiting for a response, LOG MIRROR service can be stopped by modifying LOG\_MIRROR\_TIMEOUT as follows.

```
gSQL> ALTER SYSTEM SET LOG_MIRROR_TIMEOUT = 20;
System altered.
```

## Initializing Replication

Initializing replication of LOGMIRROR should be done manually. This is to prevent data dropping or the unrecoverable situation driven by the user's incorrect option usage.



Control files and redo log files are stored in LOGMIRROR slave. The required information for the operation is stored and updated in the control files.

## Examples of Initializing Replication

- Terminate LOGMIRROR in operation in the slave device as follows.

```
prompt> logmirror --slave --stop
stop done.
```

- Terminate LOGMIRROR in operation in the master device as follows.

```
prompt> logmirror --master --stop
stop done.
```

- Drop the replicated control files and redo log files from the slave device.
  - For more information about the path, refer to 'LOG\_PATH' option described in the slave configuration file.
  - The default LOGMIRROR slave configuration file is \$GOLDILOCKS\_DATA/conf/logmirror.slave.conf.

## CYFILE

For more information about how to operate and its options, refer to **CYFILE**.

### Starting, Stopping and Status Checking of cyfile

#### Example

- Start cyfile from the current moment by using the default configuration file.

```
prompt> cyfile --start --reset all
Startup done.
```

- Stop cyfile.

```
prompt> cyfile --stop
Stop done.
```

- CYFILE is operated in groups and the data file is created in groups.

```
prompt> cyfile --status
cyfile --status
=====
|          CYFILE STATUS          |
=====
GROUP1 Running...
=====
```



## 8.3 Trace Log

The followings are detailed information about the trace log.

**Table 8-2** Trace log

| Name      | Category | File name                     |
|-----------|----------|-------------------------------|
| CYCLONE   | Master   | cyclone_master_GROUP_NAME.trc |
|           | Slave    | cyclone_slave_GROUP_NAME.trc  |
| LOGMIRROR | Master   | LogMirror_master.trc          |
|           | Slave    | LogMirror_slave.trc           |
| CYFILE    | -        | cyfile_GROUP_NAME.trc         |

## Troubleshooting of CYCLONE

The followings are error messages and troubleshooting of CYCLONE.

**Table 8-3** Troubleshooting of CYCLONE

| Error message                                                     | Solution                                                                                                                                      |
|-------------------------------------------------------------------|-----------------------------------------------------------------------------------------------------------------------------------------------|
| Service is not available                                          | Ensure that GOLDILOCKS is normally running.                                                                                                   |
| table does not exist                                              | Check the table name described in the configuration file.                                                                                     |
| schema does not exist                                             | Check the schema name described in the configuration file.                                                                                    |
| previously added. Maybe duplicated                                | Check if a table is duplicated in the configuration file.                                                                                     |
| table must have a primary key                                     | Ensure that a table in the configuration file has the primary key.                                                                            |
| internal error occurred.                                          | Check the error details.                                                                                                                      |
| table must set supplemental log                                   | Ensure that supplemental logging is executed in GOLDILOCKS.                                                                                   |
| group XXX is already running                                      | Check if the corresponding group is already running.                                                                                          |
| GOLDILOCKS_DATA system environment is invalid                     | Ensure that GOLDILOCKS_DATA environment variable is set.                                                                                      |
| log file reused or invalid. restart cyclone with '--reset' option | This error occurs when the redo log file is reused or archived redo log file does not exist. In this case, initialize CYCLONE and restart it. |
| fail to analyze flow                                              | This error occurs when analyzing an abnormal redo log file. Ensure that the release version between master and slave are same.                |
| Communication link failure                                        | Check the network state. Restart CYCLONE.                                                                                                     |
| Master disconnect abnormally                                      | Check the network state. Restart CYCLONE.                                                                                                     |
| Protocol error occurred                                           | Check the error details.                                                                                                                      |
| Already slave connected                                           | Check if the slave is already running.                                                                                                        |
| Invalid group name                                                | Check the specified group name at the startup/termination. The group name                                                                     |

| Error message                | Solution                                                                                                                           |
|------------------------------|------------------------------------------------------------------------------------------------------------------------------------|
|                              | should be same as described in the configuration file.                                                                             |
| Invalid capture information  | This error occurs when the existing operating information is abnormal. In this case, initialize CYCLONE and restart it.            |
| Redo log file read timeout   | Ensure that the archived redo log files normally exist.                                                                            |
| Invalid archive log file     | The archived redo log file is not normal. In this case, initialize CYCLONE and restart it.                                         |
| Fail to write file           | Check the available space in the disk, and restart CYCLONE.                                                                        |
| Invalid Meta File            | This error occurs when the meta files which are managed by CYCLONE are corrupted. In this case, initialize CYCLONE and restart it. |
| Redo log file does not exist | Ensure that GOLDDILOCKS which is operated as master is normally running.                                                           |
| [APPLIER-INSERT] XXX         | INSERT is failed due to XXX.                                                                                                       |
| [APPLIER-DELETE] XXX         | DELETE is failed due to XXX.                                                                                                       |
| [APPLIER-UPDATE] XXX         | UPDATE is failed due to XXX.                                                                                                       |

## Troubleshooting of LOGMIRROR

The followings are error messages and troubleshooting of LOGMIRROR.

**Table 8-4** Troubleshooting of LOGMIRROR

| Error message                                  | Solution                                                                                                                    |
|------------------------------------------------|-----------------------------------------------------------------------------------------------------------------------------|
| Service is not available                       | Ensure that GOLDDILOCKS is normally running.                                                                                |
| Invalid Protocol value                         | Check the error details.                                                                                                    |
| file does not exist                            | Ensure that the corresponding file normally exists.                                                                         |
| invalid Control file                           | The control file is corrupted. Initialize and restart LOGMIRROR.                                                            |
| Communication link failure                     | Check the network state. Restart LOGMIRROR.                                                                                 |
| GOLDDILOCKS_DATA system environment is invalid | Ensure that GOLDDILOCKS_DATA environment variable is set.                                                                   |
| There is no Shared Memory Area for LogMirror   | Ensure that LOG_MIRROR_MODE property is normally set to 'enabled' in properties of GOLDDILOCKS which is operated as master. |
| Master disconnect abnormally                   | Check the network state. Restart LOGMIRROR.                                                                                 |
| Invalid Log File                               | Ensure that the corresponding file normally exists.                                                                         |
| Connection Information does not exist          | Ensure that GOLDDILOCKS connecting information in configuration files is normal.                                            |
| Archive Log File does not exist                | Ensure that ARCHIVELOG_MODE in GOLDDILOCKS which is operated as master is normally set.                                     |

## Troubleshooting of CYFILE

The followings are error messages and troubleshooting of CYFILE.

| Error message                                                    | Solution                                                                                                                                     |
|------------------------------------------------------------------|----------------------------------------------------------------------------------------------------------------------------------------------|
| Service is not available                                         | Ensure that GOLDILOCKS is normally running.                                                                                                  |
| table does not exist                                             | Check the table name described in the configuration file.                                                                                    |
| schema does not exist                                            | Check the schema name described in the configuration file.                                                                                   |
| previously added. Maybe duplicated                               | Check if a table is duplicated in the configuration file.                                                                                    |
| table must have a primary key                                    | Ensure that a table in the configuration file has the primary key.                                                                           |
| internal error occurred.                                         | Check the error details.                                                                                                                     |
| table must set supplemental log                                  | Ensure that supplemental logging is executed in GOLDILOCKS.                                                                                  |
| group XXX is already running                                     | Check if the corresponding group is already running.                                                                                         |
| GOLDILOCKS_DATA system environment is invalid                    | Ensure that GOLDILOCKS_DATA environment variable is set.                                                                                     |
| log file reused or invalid. restart cyfile with '--reset' option | This error occurs when the redo log file is reused or archived redo log file does not exist. In this case, initialize cyfile and restart it. |
| fail to analyze flow                                             | This error occurs when analyzing an abnormal redo log file.<br>Ensure that the release version between master and slave are same.            |
| Invalid group name                                               | Check the specified group name at the startup/termination. The group name should be same as described in the configuration file.             |
| Invalid capture information                                      | This error occurs when the existing operating information is abnormal. In this case, initialize cyfile and restart it.                       |
| Redo log file read timeout                                       | Ensure that the archived redo log files normally exist.                                                                                      |
| Invalid archive log file                                         | The archived redo log file is not normal. In this case, initialize cyfile and restart it.                                                    |
| Fail to write file                                               | Check the available space in the disk, and restart cyfile.                                                                                   |
| Invalid Meta File                                                | This error occurs when the meta files which are managed by cyfile are corrupted. In this case, initialize cyfile and restart it.             |
| Redo log file does not exist                                     | Ensure that GOLDILOCKS is normally running.                                                                                                  |
| Control has broken(CRC Error)                                    | The control file of cyfile is damaged. Retry it by using the mirror file.                                                                    |



9.

---

## Database Information

## 9.1 DICTIONARY\_SCHEMA

DICTIONARY\_SCHEMA contains views or tables to get SQL objects and their information in the system.



The views and tables in DICTIONARY\_SCHEMA can be retrieved from the open phase.

Execute *DictionarySchema.sql* as follows to use the views.

- For standalone

```
% gsql sys gliese --as sysdba --import $GOLDILOCKS_HOME/admin/standalone/DictionarySchema.sql
```

- For cluster

```
% gsql sys gliese --as sysdba --import $GOLDILOCKS_HOME/admin/cluster/DictionarySchema.sql
```

Information is retrieved as follows according to the names of views or tables.

- ALL-family view
  - The view name begins with ALL\_
  - Information about accessible objects by a current user
- DBA-family view
  - The view name begins with DBA\_
  - Information about all objects whose current user has DBA privileges (ACCESS CONTROL ON DATABASE).
- USER-family view
  - The view name begins with USER\_
  - Information about objects which are owned by the current user

## Views of ALL\_family

It retrieves information about objects accessible by a current user.

### ALL\_ALL\_TABLES

ALL\_ALL\_TABLES describes the object tables and relational tables accessible to the current user.

**Table 9-1** Column information

| Column name     | Data type    | Description                                                                                                                                          |
|-----------------|--------------|------------------------------------------------------------------------------------------------------------------------------------------------------|
| OWNER           | VARCHAR(128) | Owner of the table                                                                                                                                   |
| TABLE_SCHEMA    | VARCHAR(128) | Schema of the table                                                                                                                                  |
| TABLE_NAME      | VARCHAR(128) | Name of the table                                                                                                                                    |
| TABLESPACE_NAME | VARCHAR(128) | Name of the tablespace containing the table                                                                                                          |
| CLUSTER_NAME    | VARCHAR(128) | <ul style="list-style-type: none"> <li>reserved</li> </ul> Name of the cluster                                                                       |
| IOT_NAME        | VARCHAR(128) | <ul style="list-style-type: none"> <li>reserved</li> </ul> Name of the index-organized table                                                         |
| STATUS          | VARCHAR(32)  | If a previous DROP TABLE operation failed, indicates whether the table is unusable (UNUSABLE) or valid (VALID)                                       |
| PCT_FREE        | NUMBER       | Minimum percentage of free space in a block                                                                                                          |
| PCT_USED        | NUMBER       | Minimum percentage of used space in a block                                                                                                          |
| INI_TRANS       | NUMBER       | Initial number of transactions                                                                                                                       |
| MAX_TRANS       | NUMBER       | Maximum number of transactions                                                                                                                       |
| INITIAL_EXTENT  | NUMBER       | Size of the initial extent (in bytes)                                                                                                                |
| NEXT_EXTENT     | NUMBER       | Size of secondary extents (in bytes)                                                                                                                 |
| MIN_EXTENTS     | NUMBER       | Minimum number of extents allowed in the segment                                                                                                     |
| MAX_EXTENTS     | NUMBER       | Maximum number of extents allowed in the segment                                                                                                     |
| PCT_INCREASE    | NUMBER       | <ul style="list-style-type: none"> <li>reserved</li> </ul> Percentage increase in extent size                                                        |
| FREELISTS       | NUMBER       | <ul style="list-style-type: none"> <li>reserved</li> </ul> Number of process freelists allocated to the segment                                      |
| FREELIST_GROUPS | NUMBER       | <ul style="list-style-type: none"> <li>reserved</li> </ul> Number of freelist groups allocated to the segment                                        |
| LOGGING         | VARCHAR(3)   | Indicates whether or not changes to the table are logged                                                                                             |
| BACKED_UP       | VARCHAR(1)   | <ul style="list-style-type: none"> <li>reserved</li> </ul> Indicates whether the table has been backed up since the last modification (Y) or not (N) |
| NUM_ROWS        | NUMBER       | Number of rows in the table                                                                                                                          |

| Column name               | Data type                         | Description                                                                                                                                                                                                             |
|---------------------------|-----------------------------------|-------------------------------------------------------------------------------------------------------------------------------------------------------------------------------------------------------------------------|
| BLOCKS                    | NUMBER                            | Number of used blocks in the table                                                                                                                                                                                      |
| EMPTY_BLOCKS              | NUMBER                            | <ul style="list-style-type: none"> <li>reserved</li> </ul> Number of empty (never used) blocks in the table                                                                                                             |
| AVG_SPACE                 | NUMBER                            | <ul style="list-style-type: none"> <li>reserved</li> </ul> Average available free space in the table                                                                                                                    |
| CHAIN_CNT                 | NUMBER                            | <ul style="list-style-type: none"> <li>reserved</li> </ul> Number of rows in the table that are chained from one data block to another or that have migrated to a new block, requiring a link to preserve the old rowid |
| AVG_ROW_LEN               | NUMBER                            | <ul style="list-style-type: none"> <li>reserved</li> </ul> Average row length, including row overhead                                                                                                                   |
| AVG_SPACE_FREELIST_BLOCKS | NUMBER                            | <ul style="list-style-type: none"> <li>reserved</li> </ul> Average freespace of all blocks on a freelist                                                                                                                |
| NUM_FREELIST_BLOCKS       | NUMBER                            | <ul style="list-style-type: none"> <li>reserved</li> </ul> Number of blocks on the freelist                                                                                                                             |
| DEGREE                    | VARCHAR(32)                       | <ul style="list-style-type: none"> <li>reserved</li> </ul> Number of threads per instance for scanning the table, or DEFAULT                                                                                            |
| INSTANCES                 | VARCHAR(32)                       | <ul style="list-style-type: none"> <li>reserved</li> </ul> Number of instances across which the table is to be scanned, or DEFAULT                                                                                      |
| CACHE                     | VARCHAR(1)                        | <ul style="list-style-type: none"> <li>reserved</li> </ul> Indicates whether the table is to be cached in the buffer cache (Y) or not (N)                                                                               |
| TABLE_LOCK                | VARCHAR(32)                       | Indicates whether table locking is enabled (ENABLED) or disabled (DISABLED)                                                                                                                                             |
| SAMPLE_SIZE               | NUMBER                            | Sample size used in analyzing the table                                                                                                                                                                                 |
| LAST_ANALYZED             | TIMESTAMP(6)<br>WITHOUT TIME ZONE | Date on which the table was most recently analyzed                                                                                                                                                                      |
| PARTITIONED               | VARCHAR(3)                        | <ul style="list-style-type: none"> <li>reserved</li> </ul> Indicates whether the table is partitioned (YES) or not (NO)                                                                                                 |
| IOT_TYPE                  | VARCHAR(32)                       | <ul style="list-style-type: none"> <li>reserved</li> </ul> If the table is an index-organized table, then IOT_TYPE is IOT, IOT_OVERFLOW, or IOT_MAPPING.                                                                |
| OBJECT_ID_TYPE            | VARCHAR(32)                       | <ul style="list-style-type: none"> <li>reserved</li> </ul> Indicates whether the object ID (OID) is USER-DEFINED or SYSTEM GENERATED                                                                                    |
| TABLE_TYPE_OWNER          | VARCHAR(128)                      | <ul style="list-style-type: none"> <li>reserved</li> </ul> If an object table, owner of the type from which the table is created                                                                                        |
| TABLE_TYPE                | VARCHAR(128)                      | <ul style="list-style-type: none"> <li>reserved</li> </ul> If an object table, type of the table                                                                                                                        |
| TEMPORARY                 | VARCHAR(1)                        | Indicates whether the table is temporary (Y) or not (N)                                                                                                                                                                 |



| Column name      | Data type    | Description                                                                                                                                                                              |
|------------------|--------------|------------------------------------------------------------------------------------------------------------------------------------------------------------------------------------------|
| SECONDARY        | VARCHAR(1)   | <ul style="list-style-type: none"> <li>reserved</li> </ul> Indicates whether the table is a secondary object created by cartridge                                                        |
| NESTED           | VARCHAR(3)   | <ul style="list-style-type: none"> <li>reserved</li> </ul> Indicates whether the table is a nested table (YES) or not (NO)                                                               |
| BUFFER_POOL      | VARCHAR(32)  | <ul style="list-style-type: none"> <li>reserved</li> </ul> Buffer pool to be used for table blocks                                                                                       |
| FLASH_CACHE      | VARCHAR(32)  | <ul style="list-style-type: none"> <li>reserved</li> </ul> Database Smart Flash Cache hint to be used for table blocks                                                                   |
| CELL_FLASH_CACHE | VARCHAR(32)  | Cell flash cache hint to be used for table blocks                                                                                                                                        |
| ROW_MOVEMENT     | VARCHAR(32)  | <ul style="list-style-type: none"> <li>reserved</li> </ul> If a partitioned table, indicates whether row movement is enabled (ENABLED) or disabled (DISABLED)                            |
| GLOBAL_STATS     | VARCHAR(3)   | <ul style="list-style-type: none"> <li>reserved</li> </ul> For partitioned tables, indicates whether statistics for the table as a whole (global statistics) are accurate (YES)          |
| USER_STATS       | VARCHAR(3)   | <ul style="list-style-type: none"> <li>reserved</li> </ul> Indicates whether statistics were entered directly by the user (YES) or not (NO)                                              |
| DURATION         | VARCHAR(32)  | Indicates the duration of a temporary table, the value is in ( TRANSACTION, SESSION )                                                                                                    |
| SKIP_CORRUPT     | VARCHAR(32)  | <ul style="list-style-type: none"> <li>reserved</li> </ul> Indicates whether Database ignores blocks marked corrupt during table and index scans (ENABLED) or raises an error (DISABLED) |
| MONITORING       | VARCHAR(3)   | <ul style="list-style-type: none"> <li>reserved</li> </ul> Indicates whether the table has the MONITORING attribute set (YES) or not (NO)                                                |
| CLUSTER_OWNER    | VARCHAR(128) | <ul style="list-style-type: none"> <li>reserved</li> </ul> Owner of the cluster, if any                                                                                                  |
| DEPENDENCIES     | VARCHAR(32)  | <ul style="list-style-type: none"> <li>reserved</li> </ul> Indicates whether row-level dependency tracking is enabled (ENABLED) or disabled (DISABLED)                                   |
| COMPRESSION      | VARCHAR(32)  | <ul style="list-style-type: none"> <li>reserved</li> </ul> Indicates whether table compression is enabled (ENABLED) or not (DISABLED)                                                    |
| COMPRESS_FOR     | VARCHAR(32)  | <ul style="list-style-type: none"> <li>reserved</li> </ul> Default compression for what kind of operations                                                                               |
| DROPPED          | VARCHAR(3)   | Indicates whether the table has been dropped and is in the recycle bin (YES) or not (NO)                                                                                                 |
| READ_ONLY        | VARCHAR(3)   | Indicates whether the table IS READ-ONLY (YES) or not (NO)                                                                                                                               |
| SEGMENT_CREATED  | VARCHAR(3)   | Indicates whether the table segment has been created (YES) or not (NO)                                                                                                                   |

| Column name | Data type | Description |
|-------------|-----------|-------------|
| TED         |           |             |

## ALL\_ARGUMENTS

ALL\_ARGUMENTS lists all arguments of functions, procedures.

**Table 9-2** Column information

| Column name        | Data type    | Description                                                           |
|--------------------|--------------|-----------------------------------------------------------------------|
| OWNER              | VARCHAR(128) | Owner of function, procedures or package                              |
| SCHEMA_NAME        | VARCHAR(128) | Schema Name of function, procedures or package                        |
| OBJECT_NAME        | VARCHAR(128) | Name of function, procedures                                          |
| PACKAGE_NAME       | VARCHAR(128) | Package Name of function, procedures                                  |
| OBJECT_ID          | NUMBER       | ID of a function, procedures                                          |
| SUBPROGRAM_ID      | NUMBER       | ID of procedures in package                                           |
| ARGUMENT_NAME      | VARCHAR(128) | Name of argument or attribute name of record type argument            |
| POSITION           | NUMBER       | Position of argument or position of attribute in record type          |
| SEQUENCE           | NUMBER       | Sequential order of argument and its attributes                       |
| DATA_LEVEL         | NUMBER       | Nesting depth of the argument for composite types                     |
| DATA_TYPE          | VARCHAR(128) | Data type of the argument                                             |
| DEFAULTED          | VARCHAR(1)   | Whether or not the argument is defaulted                              |
| DEFAULT_VALUE      | VARCHAR(1)   | Reserved for future use                                               |
| DEFAULT_LENGTH     | VARCHAR(1)   | Reserved for future use                                               |
| IN_OUT             | VARCHAR(32)  | Direction of the argument (IN, OUT, IN/OUT)                           |
| DATA_LENGTH        | NUMBER       | Length of the column(in bytes)                                        |
| DATA_PRECISION     | NUMBER       | Length in decimal digits(NUMBER) or binary digits(FLOAT)              |
| DATA_SCALE         | NUMBER       | Digits to the right of the decimal point in a number                  |
| RADIX              | NUMBER       | Argument radix for a number                                           |
| CHARACTER_SET_NAME | VARCHAR(128) | Character set name for the argument                                   |
| TYPE_OWNER         | VARCHAR(128) | Owner of the type of the argument                                     |
| TYPE_NAME          | VARCHAR(128) | Name of the type of the argument                                      |
| TYPE_SUBNAME       | VARCHAR(128) | Name of the type of the argument declared in package                  |
| TYPE_LINK          | VARCHAR(128) | Name of the type of the argument declared in a remote package         |
| PLS_TYPE           | VARCHAR(128) | Name of the type of the argument at PSM                               |
| CHAR_LENGTH        | NUMBER       | Character limit for string datatypes                                  |
| CHAR_USED          | VARCHAR(1)   | Whether the byte limit(B) or char limit(C) is official for the string |
| ORIGIN_CON_ID      | VARCHAR(256) | ID of the container where the data originates                         |

## ALL\_CATALOG

ALL\_CATALOG displays the tables, views, synonyms, and sequences accessible to the current user.

**Table 9-3** Column information

| Column name  | Data type    | Description                                                |
|--------------|--------------|------------------------------------------------------------|
| OWNER        | VARCHAR(128) | Owner of the TABLE, VIEW, SYNONYM, SEQUENCE, or UNDEFINED  |
| TABLE_SCHEMA | VARCHAR(128) | Schema of the TABLE, VIEW, SYNONYM, SEQUENCE, or UNDEFINED |
| TABLE_NAME   | VARCHAR(128) | Name of the TABLE, VIEW, SYNONYM, SEQUENCE, or UNDEFINED   |
| TABLE_TYPE   | VARCHAR(32)  | Type of the TABLE, VIEW, SYNONYM, SEQUENCE, or UNDEFINED   |

## ALL\_CLUSTER\_TABLES

ALL\_CLUSTER\_TABLES describes all cluster tables accessible to the current user in the cluster system.



It is available only on a cluster.

**Table 9-4** Column information

| Column name     | Data type    | Description                                                                                                |
|-----------------|--------------|------------------------------------------------------------------------------------------------------------|
| OWNER           | VARCHAR(128) | Owner of the table                                                                                         |
| TABLE_SCHEMA    | VARCHAR(128) | Schema of the table                                                                                        |
| TABLE_NAME      | VARCHAR(128) | Name of the table                                                                                          |
| SHARD_STRATEGY  | VARCHAR(32)  | Sharding strategy of the table:<br>the value in (CLONED, HASH SHARDING, RANGE SHARDING, LIST S<br>HARDING) |
| SHARD_PLACEMENT | VARCHAR(32)  | Shard placement of the table:<br>the value in (AT CLUSTER WIDE or AT CLUSTER GROUP)                        |
| SHARD_COUNT     | NUMBER       | Shard count of the table (if cloned table, the value is null)                                              |
| SHARD_KEY_COUNT | NUMBER       | Shard key column count of the table (if cloned table, the value is nul<br>l)                               |
| HAS_GSI         | VARCHAR(3)   | Indicate whether the table has global secondary index: (YES) or (NO<br>)                                   |
| DROPPED         | VARCHAR(3)   | Indicates whether the table has been dropped and is in the recycle b<br>in (YES) or not (NO)               |

## ALL\_COL\_COMMENTS

ALL\_COL\_COMMENTS displays comments on the columns of the tables and views accessible to the current user.

**Table 9-5** Column information

| Column name  | Data type     | Description           |
|--------------|---------------|-----------------------|
| OWNER        | VARCHAR(128)  | Owner of the object   |
| TABLE_SCHEMA | VARCHAR(128)  | Schema of the object  |
| TABLE_NAME   | VARCHAR(128)  | Name of the object    |
| COLUMN_NAME  | VARCHAR(128)  | Name of the column    |
| COMMENTS     | VARCHAR(1024) | Comment on the column |

## ALL\_COL\_PRIVS

ALL\_COL\_PRIVS describes the object grants, for which the current user is the object owner, grantor, or grantee, or for which an enabled role or PUBLIC is the grantee.

**Table 9-6** Column information

| Column name  | Data type    | Description                                                                         |
|--------------|--------------|-------------------------------------------------------------------------------------|
| GRANTOR      | VARCHAR(128) | Name of the user who performed the grant                                            |
| GRANTEE      | VARCHAR(128) | Name of the user or role to whom access was granted                                 |
| OWNER        | VARCHAR(128) | Owner of the object                                                                 |
| TABLE_SCHEMA | VARCHAR(128) | Schema of the object                                                                |
| TABLE_NAME   | VARCHAR(128) | Name of the object                                                                  |
| COLUMN_NAME  | VARCHAR(128) | Name of the column                                                                  |
| PRIVILEGE    | VARCHAR(32)  | Privilege on the column                                                             |
| GRANTABLE    | VARCHAR(3)   | Indicates whether the privilege was granted with the GRANT OPTION (YES) or not (NO) |

## ALL\_COL\_PRIVS\_MADE

ALL\_COL\_PRIVS\_MADE describes the column object grants for which the current user is the object owner or grantor.

**Table 9-7** Column information

| Column name  | Data type    | Description                                                                         |
|--------------|--------------|-------------------------------------------------------------------------------------|
| GRANTEE      | VARCHAR(128) | Name of the user or role to whom access was granted                                 |
| OWNER        | VARCHAR(128) | Owner of the object                                                                 |
| TABLE_SCHEMA | VARCHAR(128) | Schema of the object                                                                |
| TABLE_NAME   | VARCHAR(128) | Name of the object                                                                  |
| COLUMN_NAME  | VARCHAR(128) | Name of the column                                                                  |
| GRANTOR      | VARCHAR(128) | Name of the user who performed the grant                                            |
| PRIVILEGE    | VARCHAR(32)  | Privilege on the column                                                             |
| GRANTABLE    | VARCHAR(3)   | Indicates whether the privilege was granted with the GRANT OPTION (YES) or not (NO) |



## ALL\_COL\_PRIVS\_RECD

ALL\_COL\_PRIVS\_RECD describes the column object grants, for which the current user is the grantee, or for which an enabled role or PUBLIC is the grantee.

**Table 9-8** Column information

| Column name  | Data type    | Description                                                                         |
|--------------|--------------|-------------------------------------------------------------------------------------|
| GRANTEE      | VARCHAR(128) | Name of the user or role to whom access was granted                                 |
| OWNER        | VARCHAR(128) | Owner of the object                                                                 |
| TABLE_SCHEMA | VARCHAR(128) | Schema of the object                                                                |
| TABLE_NAME   | VARCHAR(128) | Name of the object                                                                  |
| COLUMN_NAME  | VARCHAR(128) | Name of the column                                                                  |
| GRANTOR      | VARCHAR(128) | Name of the user who performed the grant                                            |
| PRIVILEGE    | VARCHAR(32)  | Privilege on the column                                                             |
| GRANTABLE    | VARCHAR(3)   | Indicates whether the privilege was granted with the GRANT OPTION (YES) or not (NO) |

## ALL\_CONSTRAINTS

ALL\_CONSTRAINTS describes constraint definitions on tables accessible to the current user.

**Table 9-9** Column information

| Column name       | Data type                      | Description                                                                                                                                                                         |
|-------------------|--------------------------------|-------------------------------------------------------------------------------------------------------------------------------------------------------------------------------------|
| OWNER             | VARCHAR(128)                   | Owner of the constraint definition                                                                                                                                                  |
| CONSTRAINT_SCHEMA | VARCHAR(128)                   | Schema of the constraint definition                                                                                                                                                 |
| CONSTRAINT_NAME   | VARCHAR(128)                   | Name of the constraint definition                                                                                                                                                   |
| CONSTRAINT_TYPE   | VARCHAR(1)                     | Type of the constraint definition: the value in ( C: check constraint, P: Primary key, U: Unique Key, R: Referential integrity )                                                    |
| TABLE_OWNER       | VARCHAR(128)                   | Owner of the table (or view) associated with the constraint definition                                                                                                              |
| TABLE_SCHEMA      | VARCHAR(128)                   | Schema of the table (or view) associated with the constraint definition                                                                                                             |
| TABLE_NAME        | VARCHAR(128)                   | Name of the table (or view) associated with the constraint definition                                                                                                               |
| SEARCH_CONDITION  | LONG VARCHAR                   | Text of search condition for a check constraint                                                                                                                                     |
| R_OWNER           | VARCHAR(128)                   | Owner of the unique constraint definition for the referenced table                                                                                                                  |
| R_SCHEMA          | VARCHAR(128)                   | Schema of the unique constraint definition for the referenced table                                                                                                                 |
| R_CONSTRAINT_NAME | VARCHAR(128)                   | Name of the unique constraint definition for the referenced table                                                                                                                   |
| DELETE_RULE       | VARCHAR(32)                    | Delete rule for a referential constraint: the value in ( NO ACTION, RESTRICT, CASCADE, SET NULL, SET DEFAULT )                                                                      |
| UPDATE_RULE       | VARCHAR(32)                    | Update rule for a referential constraint: the value in ( NO ACTION, RESTRICT, CASCADE, SET NULL, SET DEFAULT )                                                                      |
| STATUS            | VARCHAR(32)                    | Enforcement status of the constraint: the value in ( ENABLED, DISABLE )                                                                                                             |
| DEFERRABLE        | VARCHAR(32)                    | Indicates whether the constraint is deferrable (DEFERRABLE) or not (NOT DEFERRABLE)                                                                                                 |
| DEFERRED          | VARCHAR(32)                    | Indicates whether the constraint was initially deferred (DEFERRED) or not (IMMEDIATE)                                                                                               |
| VALIDATED         | VARCHAR(32)                    | Indicates whether all data may obey the constraint or not: the value in ( VALIDATED, NOT VALIDATED )                                                                                |
| GENERATED         | VARCHAR(32)                    | Indicates whether the name of the constraint is user-generated (USER NAME) or system-generated (GENERATED NAME)                                                                     |
| BAD               | VARCHAR(32)                    | <ul style="list-style-type: none"> <li>reserved</li> </ul> Indicates whether this constraint specifies a century in an ambiguous manner (BAD) or not (NULL)                         |
| RELY              | VARCHAR(32)                    | <ul style="list-style-type: none"> <li>reserved</li> </ul> When NOT VALIDATED, indicates whether the constraint is to be taken in to account for query rewrite (RELY) or not (NULL) |
| LAST_CHANGE       | TIMESTAMP(2) WITHOUT TIME ZONE | When the constraint was last enabled or disabled                                                                                                                                    |

| Column name  | Data type     | Description                                                                                   |
|--------------|---------------|-----------------------------------------------------------------------------------------------|
| INDEX_OWNER  | VARCHAR(128)  | Owner of the index associated with the key constraint                                         |
| INDEX_SCHEMA | VARCHAR(128)  | Schema of the index associated with the key constraint                                        |
| INDEX_NAME   | VARCHAR(128)  | Name of the index associated with the key constraint                                          |
| INVALID      | VARCHAR(32)   | Indicates whether the constraint is invalid (INVALID) or not (NULL)                           |
| VIEW_RELATED | VARCHAR(32)   | Indicates whether the constraint depends on a view (DEPEND ON VIEW) or not (NULL)             |
| DROPPED      | VARCHAR(3)    | Indicates whether the constraint has been dropped and is in the recycle bin (YES) or not (NO) |
| COMMENTS     | VARCHAR(1024) | Comments of the constraint definition                                                         |

## ALL\_CONS\_COLUMNS

ALL\_CONS\_COLUMNS describes columns that are accessible to the current user and that are specified in constraints.

**Table 9-10** Column information

| Column name       | Data type    | Description                                                                                      |
|-------------------|--------------|--------------------------------------------------------------------------------------------------|
| OWNER             | VARCHAR(128) | Owner of the constraint definition                                                               |
| CONSTRAINT_SCHEMA | VARCHAR(128) | Schema of the constraint definition                                                              |
| CONSTRAINT_NAME   | VARCHAR(128) | Name of the constraint definition                                                                |
| TABLE_OWNER       | VARCHAR(128) | Owner of the table with the constraint definition                                                |
| TABLE_SCHEMA      | VARCHAR(128) | Schema of the table with the constraint definition                                               |
| TABLE_NAME        | VARCHAR(128) | Name of the table with the constraint definition                                                 |
| COLUMN_NAME       | VARCHAR(128) | Name of the column or attribute of the object type column specified in the constraint definition |
| POSITION          | NUMBER       | Original position of the column or attribute in the definition of the object                     |

## ALL\_DB\_PRIVS

ALL\_DB\_PRIVS describes the database grants, for which the current user is the grantor, or grantee, or for which an enabled role or PUBLIC is the grantee.

**Table 9-11** Column information

| Column name | Data type    | Description                                                                         |
|-------------|--------------|-------------------------------------------------------------------------------------|
| GRANTOR     | VARCHAR(128) | Name of the user who performed the grant                                            |
| GRANTEE     | VARCHAR(128) | Name of the user or role to whom access was granted                                 |
| PRIVILEGE   | VARCHAR(32)  | Privilege on the database                                                           |
| GRANTABLE   | VARCHAR(3)   | Indicates whether the privilege was granted with the GRANT OPTION (YES) or not (NO) |

## ALL\_DB\_PRIVS\_MADE

ALL\_DB\_PRIVS\_MADE describes the database grants for which the current user is the grantor.

**Table 9-12** Column information

| Column name | Data type    | Description                                                                         |
|-------------|--------------|-------------------------------------------------------------------------------------|
| GRANTEE     | VARCHAR(128) | Name of the user or role to whom access was granted                                 |
| GRANTOR     | VARCHAR(128) | Name of the user who performed the grant                                            |
| PRIVILEGE   | VARCHAR(32)  | Privilege on the database                                                           |
| GRANTABLE   | VARCHAR(3)   | Indicates whether the privilege was granted with the GRANT OPTION (YES) or not (NO) |

## ALL\_DB\_PRIVS\_RECD

ALL\_DB\_PRIVS\_RECD describes the database grants, for which the current user is the grantee, or for which an enabled role or PUBLIC is the grantee.

**Table 9-13** Column information

| Column name | Data type    | Description                                                                         |
|-------------|--------------|-------------------------------------------------------------------------------------|
| GRANTEE     | VARCHAR(128) | Name of the user or role to whom access was granted                                 |
| GRANTOR     | VARCHAR(128) | Name of the user who performed the grant                                            |
| PRIVILEGE   | VARCHAR(32)  | Privilege on the database                                                           |
| GRANTABLE   | VARCHAR(3)   | Indicates whether the privilege was granted with the GRANT OPTION (YES) or not (NO) |

## ALL\_DEPENDENCIES

ALL\_DEPENDENCIES describes dependencies between objects accessible to the current user

**Table 9-14** Column information

| Column name            | Data type    | Description                                                                                               |
|------------------------|--------------|-----------------------------------------------------------------------------------------------------------|
| OWNER                  | VARCHAR(128) | Owner of object                                                                                           |
| SCHEMA_NAME            | VARCHAR(128) | Schema Name of object                                                                                     |
| NAME                   | VARCHAR(128) | Name of object                                                                                            |
| TYPE                   | VARCHAR(32)  | Type of object: FUNCTION, PROCEDURE, VIEW, PACKAGE, PACKAGE BODY, TRIGGER                                 |
| REFERENCED_OWNER       | VARCHAR(128) | Owner of the referenced object                                                                            |
| REFERENCED_SCHEMA_NAME | VARCHAR(128) | Schema Name of the referenced object                                                                      |
| REFERENCED_TYPE        | VARCHAR(32)  | Type of the referenced object: FUNCTION, PROCEDURE, TABLE, VIEW, SEQUENCE, PACKAGE, PACKAGE BODY, TRIGGER |
| REFERENCED_LINK_NAME   | VARCHAR(128) | Name of the link to the parent object                                                                     |
| REFERENCED_NAME        | VARCHAR(128) | Name of the referenced object                                                                             |
| DEPENDENCY_TYPE        | VARCHAR(32)  | Indicates whether the dependency is a REF dependency (REF) or not (HARD)                                  |



## ALL\_GLOBAL\_SECONDARY\_INDEXES

ALL\_GLOBAL\_SECONDARY\_INDEXES describes the global secondary indexes on the tables accessible to the current user.



It is available only on a cluster.

**Table 9-15** Column information

| Column name     | Data type    | Description                                                                                               |
|-----------------|--------------|-----------------------------------------------------------------------------------------------------------|
| TABLE_OWNER     | VARCHAR(128) | Owner of the global secondary indexed object                                                              |
| TABLE_SCHEMA    | VARCHAR(128) | Schema of the global secondary indexed object                                                             |
| TABLE_NAME      | VARCHAR(128) | Name of the global secondary indexed object                                                               |
| TABLESPACE_NAME | VARCHAR(128) | Name of the tablespace containing the global secondary index                                              |
| INI_TRANS       | NUMBER       | Initial number of transactions                                                                            |
| MAX_TRANS       | NUMBER       | Maximum number of transactions                                                                            |
| INITIAL_EXTENT  | NUMBER       | Size of the initial extent                                                                                |
| NEXT_EXTENT     | NUMBER       | Size of secondary extents                                                                                 |
| MIN_EXTENTS     | NUMBER       | Minimum number of extents allowed in the segment                                                          |
| MAX_EXTENTS     | NUMBER       | Maximum number of extents allowed in the segment                                                          |
| PCT_FREE        | NUMBER       | Minimum percentage of free space in a block                                                               |
| LOGGING         | VARCHAR(3)   | Indicates whether or not changes to the global secondary index are logged: (YES) or (NO)                  |
| BLOCKS          | NUMBER       | Number of used blocks in the global secondary index                                                       |
| EMPTY_BLOCKS    | NUMBER       | Number of empty blocks in the global secondary index                                                      |
| DROPPED         | VARCHAR(3)   | Indicates whether the global secondary index has been dropped and is in the recycle bin (YES) or not (NO) |

## ALL\_GSI\_PLACE

ALL\_GSI\_PLACE describes node placement of all global secondary indexes on the tables accessible to the current user in the cluster system.



It is available only on a cluster.

**Table 9-16** Column information

| Column name    | Data type    | Description                                                                                               |
|----------------|--------------|-----------------------------------------------------------------------------------------------------------|
| TABLE_OWNER    | VARCHAR(128) | Owner of the global secondary indexed object                                                              |
| TABLE_SCHEMA   | VARCHAR(128) | Schema of the global secondary indexed object                                                             |
| TABLE_NAME     | VARCHAR(128) | Name of the global secondary indexed object                                                               |
| GROUP_ID       | NUMBER       | Group identifier of the node where the global secondary index placed                                      |
| GROUP_NAME     | VARCHAR(128) | Group name of the node where the global secondary index placed                                            |
| MEMBER_ID      | NUMBER       | Member identifier of the node where the global secondary index placed                                     |
| MEMBER_NAME    | VARCHAR(128) | Member name of the node where the global secondary index placed                                           |
| MEMBER_OFFLINE | BOOLEAN      | data of the cluster member is offline or not                                                              |
| DROPPED        | VARCHAR(3)   | Indicates whether the global secondary index has been dropped and is in the recycle bin (YES) or not (NO) |
| BLOCKS         | NUMBER       | Number of used blocks of the node where the global secondary index placed                                 |

## ALL\_INDEXES

ALL\_INDEXES describes the indexes on the tables accessible to the current user.

**Table 9-17** Column information

| Column name     | Data type    | Description                                                                                                                                                      |
|-----------------|--------------|------------------------------------------------------------------------------------------------------------------------------------------------------------------|
| OWNER           | VARCHAR(128) | Owner of the index                                                                                                                                               |
| INDEX_SCHEMA    | VARCHAR(128) | Schema of the index                                                                                                                                              |
| INDEX_NAME      | VARCHAR(128) | Name of the index                                                                                                                                                |
| INDEX_TYPE      | VARCHAR(32)  | Type of the index: the value in ( NORMAL, NORMAL/REV, BITMAP, FUNCTION-BASED NORMAL, FUNCTION-BASED NORMAL/REV, FUNCTION-BASED BITMAP, IOT - TOP, DOMAIN )       |
| TABLE_OWNER     | VARCHAR(128) | Owner of the indexed object                                                                                                                                      |
| TABLE_SCHEMA    | VARCHAR(128) | Schema of the indexed object                                                                                                                                     |
| TABLE_NAME      | VARCHAR(128) | Name of the indexed object                                                                                                                                       |
| TABLE_TYPE      | VARCHAR(32)  | Type of the indexed object: the value in ( NEXT OBJECT, INDEX, TABLE, VIEW, SYNONYM, SEQUENCE )                                                                  |
| UNIQUENESS      | VARCHAR(32)  | Indicates whether the index is unique (UNIQUE) or nonunique (NON UNIQUE)                                                                                         |
| COMPRESSION     | VARCHAR(32)  | <ul style="list-style-type: none"> <li>reserved</li> </ul> Indicates whether index compression is enabled (ENABLED) or not (DISABLED)                            |
| PREFIX_LENGTH   | NUMBER       | <ul style="list-style-type: none"> <li>reserved</li> </ul> Number of columns in the prefix of the compression key                                                |
| TABLESPACE_NAME | VARCHAR(128) | Name of the tablespace containing the index                                                                                                                      |
| INI_TRANS       | NUMBER       | Initial number of transactions                                                                                                                                   |
| MAX_TRANS       | NUMBER       | Maximum number of transactions                                                                                                                                   |
| INITIAL_EXTENT  | NUMBER       | Size of the initial extent                                                                                                                                       |
| NEXT_EXTENT     | NUMBER       | Size of secondary extents                                                                                                                                        |
| MIN_EXTENTS     | NUMBER       | Minimum number of extents allowed in the segment                                                                                                                 |
| MAX_EXTENTS     | NUMBER       | Maximum number of extents allowed in the segment                                                                                                                 |
| PCT_INCREASE    | NUMBER       | <ul style="list-style-type: none"> <li>reserved</li> </ul> Percentage increase in extent size                                                                    |
| PCT_THRESHOLD   | NUMBER       | <ul style="list-style-type: none"> <li>reserved</li> </ul> Threshold percentage of block space allowed per index entry                                           |
| INCLUDE_COLUMN  | NUMBER       | <ul style="list-style-type: none"> <li>reserved</li> </ul> Column ID of the last column to be included in index-organized table primary key (non-overflow) index |
| FREELISTS       | NUMBER       | <ul style="list-style-type: none"> <li>reserved</li> </ul> Number of process freelists allocated to this segment                                                 |
| FREELIST_GROUPS | NUMBER       | <ul style="list-style-type: none"> <li>reserved</li> </ul> Number of freelist groups allocated to this segment                                                   |

| Column name             | Data type                      | Description                                                                                                                                                                               |
|-------------------------|--------------------------------|-------------------------------------------------------------------------------------------------------------------------------------------------------------------------------------------|
| PCT_FREE                | NUMBER                         | Minimum percentage of free space in a block                                                                                                                                               |
| LOGGING                 | VARCHAR(3)                     | Indicates whether or not changes to the index are logged: (YES) or (NO)                                                                                                                   |
| BLOCKS                  | NUMBER                         | Number of used blocks in the index                                                                                                                                                        |
| EMPTY_BLOCKS            | NUMBER                         | Number of empty blocks in the index                                                                                                                                                       |
| BLEVEL                  | NUMBER                         | <ul style="list-style-type: none"> <li>reserved</li> </ul> B-Tree level (depth of the index from its root block to its leaf blocks)                                                       |
| LEAF_BLOCKS             | NUMBER                         | <ul style="list-style-type: none"> <li>reserved</li> </ul> Number of leaf blocks in the index                                                                                             |
| DISTINCT_KEYS           | NUMBER                         | Number of distinct indexed values.                                                                                                                                                        |
| AVG_LEAF_BLOCKS_PER_KEY | NUMBER                         | <ul style="list-style-type: none"> <li>reserved</li> </ul> Average number of leaf blocks in which each distinct value in the index appears, rounded to the nearest integer                |
| AVG_DATA_BLOCKS_PER_KEY | NUMBER                         | <ul style="list-style-type: none"> <li>reserved</li> </ul> Average number of data blocks in the table that are pointed to by a distinct value in the index rounded to the nearest integer |
| CLUSTERING_FACTOR       | NUMBER                         | <ul style="list-style-type: none"> <li>reserved</li> </ul> Indicates the amount of order of the rows in the table based on the values of the index                                        |
| STATUS                  | VARCHAR(32)                    | Indicates whether a nonpartitioned index is VALID or UNUSABLE                                                                                                                             |
| NUM_ROWS                | NUMBER                         | <ul style="list-style-type: none"> <li>reserved</li> </ul> Number of rows in the index                                                                                                    |
| SAMPLE_SIZE             | NUMBER                         | Size of the sample used to analyze the index                                                                                                                                              |
| LAST_ANALYZED           | TIMESTAMP(6) WITHOUT TIME ZONE | Date on which this index was most recently analyzed                                                                                                                                       |
| DEGREE                  | VARCHAR(32)                    | <ul style="list-style-type: none"> <li>reserved</li> </ul> Number of threads per instance for scanning the index, or DEFAULT                                                              |
| INSTANCES               | VARCHAR(32)                    | <ul style="list-style-type: none"> <li>reserved</li> </ul> Number of instances across which the indexes to be scanned, or DEFAULT                                                         |
| PARTITIONED             | VARCHAR(3)                     | <ul style="list-style-type: none"> <li>reserved</li> </ul> Indicates whether the index is partitioned (YES) or not (NO)                                                                   |
| TEMPORARY               | VARCHAR(1)                     | Indicates whether the index is on a temporary table (Y) or not (N)                                                                                                                        |
| GENERATED               | VARCHAR(1)                     | Indicates whether the name of the index is system-generated (Y) or not (N)                                                                                                                |
| SECONDARY               | VARCHAR(1)                     | Indicates whether the index is a secondary object created by the method of the Data Cartridge (Y) or not (N)                                                                              |
| BUFFER_POOL             | VARCHAR(32)                    | <ul style="list-style-type: none"> <li>reserved</li> </ul> Buffer pool to be used for index blocks                                                                                        |
| FLASH_CACHE             | VARCHAR(32)                    | <ul style="list-style-type: none"> <li>reserved</li> </ul> Database Smart Flash Cache hint to be used for index blocks                                                                    |

| Column name             | Data type     | Description                                                                                                                                                                                                                                                     |
|-------------------------|---------------|-----------------------------------------------------------------------------------------------------------------------------------------------------------------------------------------------------------------------------------------------------------------|
| CELL_FLASH_CACHE        | VARCHAR(32)   | <ul style="list-style-type: none"> <li>reserved</li> </ul> Cell flash cache hint to be used for index blocks                                                                                                                                                    |
| USER_STATS              | VARCHAR(3)    | <ul style="list-style-type: none"> <li>reserved</li> </ul> Indicates whether statistics were entered directly by the user (YES) or not (NO)                                                                                                                     |
| DURATION                | VARCHAR(32)   | Indicates the duration of a temporary table, the value is in ( TRANSACTION, SESSION )                                                                                                                                                                           |
| PCT_DIRECT_ACCESSES     | NUMBER        | <ul style="list-style-type: none"> <li>reserved</li> </ul> For a secondary index on an index-organized table, the percentage of rows with VALID guess                                                                                                           |
| ITYP_OWNER              | VARCHAR(128)  | <ul style="list-style-type: none"> <li>reserved</li> </ul> For a domain index, the owner of the indextype                                                                                                                                                       |
| ITYP_NAME               | VARCHAR(128)  | <ul style="list-style-type: none"> <li>reserved</li> </ul> For a domain index, the name of the indextype                                                                                                                                                        |
| PARAMETERS              | VARCHAR(1024) | <ul style="list-style-type: none"> <li>reserved</li> </ul> For a domain index, the parameter string                                                                                                                                                             |
| GLOBAL_STATS            | VARCHAR(3)    | <ul style="list-style-type: none"> <li>reserved</li> </ul> For partitioned indexes, indicates whether statistics were collected by analyzing the index as a whole (YES) or were estimated from statistics on underlying index partitions and subpartitions (NO) |
| DOMIDX_STATUS           | VARCHAR(32)   | <ul style="list-style-type: none"> <li>reserved</li> </ul> Status of a domain index                                                                                                                                                                             |
| DOMIDX_OPSTATUS         | VARCHAR(32)   | <ul style="list-style-type: none"> <li>reserved</li> </ul> Status of the operation on a domain index                                                                                                                                                            |
| FUNCIDX_STATUS          | VARCHAR(32)   | <ul style="list-style-type: none"> <li>reserved</li> </ul> Status of a function-based index                                                                                                                                                                     |
| JOIN_INDEX              | VARCHAR(3)    | <ul style="list-style-type: none"> <li>reserved</li> </ul> Indicates whether the index is a join index (YES) or not (NO)                                                                                                                                        |
| IOT_REDUNDANT_PKEY_ELIM | VARCHAR(3)    | <ul style="list-style-type: none"> <li>reserved</li> </ul> Indicates whether redundant primary key columns are eliminated from secondary indexes on index-organized tables (YES) or not (NO)                                                                    |
| DROPPED                 | VARCHAR(3)    | Indicates whether the index has been dropped and is in the recycle bin (YES) or not (NO)                                                                                                                                                                        |
| VISIBILITY              | VARCHAR(3)    | <ul style="list-style-type: none"> <li>reserved</li> </ul> Indicates whether the index is VISIBLE or INVISIBLE to the optimizer                                                                                                                                 |
| DOMIDX_MANAGEMENT       | VARCHAR(32)   | <ul style="list-style-type: none"> <li>reserved</li> </ul> If this is a domain index, indicates whether the domain index is system-managed (SYSTEM_MANAGED) or user-managed (USER_MANAGED)                                                                      |
| SEGMENT_CREATED         | VARCHAR(3)    | Indicates whether the index segment has been created (YES) or not (NO)                                                                                                                                                                                          |

| Column name  | Data type     | Description                         |
|--------------|---------------|-------------------------------------|
| COMMENTS     | VARCHAR(1024) | Comments of the index               |
| EMPTY_BLOCKS | NUMBER        | Number of empty blocks in the index |

## ALL\_IND\_COLUMNS

ALL\_IND\_COLUMNS describes the columns of indexes on all tables accessible to the current user.

**Table 9-18** Column information

| Column name     | Data type    | Description                                                                                                                  |
|-----------------|--------------|------------------------------------------------------------------------------------------------------------------------------|
| INDEX_OWNER     | VARCHAR(128) | Owner of the index                                                                                                           |
| INDEX_SCHEMA    | VARCHAR(128) | Schema of the index                                                                                                          |
| INDEX_NAME      | VARCHAR(128) | Name of the index                                                                                                            |
| TABLE_OWNER     | VARCHAR(128) | Owner of the table or cluster                                                                                                |
| TABLE_SCHEMA    | VARCHAR(128) | Schema of the table or cluster                                                                                               |
| TABLE_NAME      | VARCHAR(128) | Name of the table or cluster                                                                                                 |
| COLUMN_NAME     | VARCHAR(128) | Column name or attribute of the object type column                                                                           |
| COLUMN_POSITION | NUMBER       | Position of the column or attribute within the index                                                                         |
| COLUMN_LENGTH   | NUMBER       | Indexed length of the column                                                                                                 |
| CHAR_LENGTH     | NUMBER       | Maximum codepoint length of the column                                                                                       |
| DESCEND         | VARCHAR(32)  | Indicates whether the column is sorted in descending order (DESC) or ascending order (ASC)                                   |
| NULL_ORDER      | VARCHAR(32)  | Indicates whether the null value of the column is sorted in nulls first order (NULLS FIRST) or nulls last order (NULLS LAST) |

## ALL\_IND\_PLACE

ALL\_IND\_PLACE describes node placement of the indexes on the tables accessible to the current user in the cluster system.



It is available only on a cluster.

**Table 9-19** Column information

| Column name    | Data type                          | Description                                                                              |
|----------------|------------------------------------|------------------------------------------------------------------------------------------|
| OWNER          | VARCHAR(128)                       | Owner of the index                                                                       |
| INDEX_SCHEMA   | VARCHAR(128)                       | Schema of the index                                                                      |
| INDEX_NAME     | VARCHAR(128)                       | Name of the index                                                                        |
| TABLE_OWNER    | VARCHAR(128)                       | Owner of the indexed object                                                              |
| TABLE_SCHEMA   | VARCHAR(128)                       | Schema of the indexed object                                                             |
| TABLE_NAME     | VARCHAR(128)                       | Name of the indexed object                                                               |
| GROUP_ID       | NUMBER                             | Group identifier of the node where the index placed                                      |
| GROUP_NAME     | VARCHAR(128)                       | Group name of the node where the index placed                                            |
| MEMBER_ID      | NUMBER                             | Member identifier of the node where the index placed                                     |
| MEMBER_NAME    | VARCHAR(128)                       | Member name of the node where the index placed                                           |
| MEMBER_OFFLINE | BOOLEAN                            | data of the cluster member is offline or not                                             |
| DROPPED        | VARCHAR(3)                         | Indicates whether the index has been dropped and is in the recycle bin (YES) or not (NO) |
| DISTINCT_KEYS  | NUMBER                             | (deprecated)                                                                             |
| SAMPLE_SIZE    | NUMBER                             | (deprecated)                                                                             |
| BLOCKS         | NUMBER                             | Number of used blocks of the node where the index placed                                 |
| LAST_ANALYZED  | TIMESTAMP(2) WITH<br>OUT TIME ZONE | (deprecated)                                                                             |



## ALL\_NONSCHEMA\_COMMENTS

ALL\_NONSCHEMA\_COMMENTS displays comments on all non-schema objects (database, authorizations, schemas, tablespaces) accessible to the current user.

**Table 9-20** Column information

| Column name | Data type     | Description                                                                |
|-------------|---------------|----------------------------------------------------------------------------|
| OBJECT_NAME | VARCHAR(128)  | Name of the non-schema object                                              |
| OBJECT_TYPE | VARCHAR(32)   | Type of the non-schema object: DATABASE, AUTHORIZATION, SCHEMA, TABLESPACE |
| COMMENTS    | VARCHAR(1024) | Comments of the non-schema object                                          |

## ALL\_OBJECTS

ALL\_OBJECTS describes all objects accessible to the current user.

**Table 9-21** Column information

| Column name    | Data type                         | Description                                                                                                                                                                               |
|----------------|-----------------------------------|-------------------------------------------------------------------------------------------------------------------------------------------------------------------------------------------|
| OWNER          | VARCHAR(128)                      | Owner of the object                                                                                                                                                                       |
| SCHEMA_NAME    | VARCHAR(128)                      | Schema of the object                                                                                                                                                                      |
| OBJECT_NAME    | VARCHAR(128)                      | Name of the object                                                                                                                                                                        |
| SUBOBJECT_NAME | VARCHAR(128)                      | Name of the subobject (for example, partition)                                                                                                                                            |
| OBJECT_ID      | NUMBER                            | Dictionary object number of the object                                                                                                                                                    |
| DATA_OBJECT_ID | NUMBER                            | Dictionary object number of the segment that contains the object                                                                                                                          |
| OBJECT_TYPE    | VARCHAR(32)                       | Type of the object (such as TABLE, INDEX)                                                                                                                                                 |
| CREATED        | TIMESTAMP(2)<br>WITHOUT TIME ZONE | Timestamp for the creation of the object                                                                                                                                                  |
| LAST_DDL_TIME  | TIMESTAMP(2)<br>WITHOUT TIME ZONE | Timestamp for the last modification of the object resulting from a DDL statement                                                                                                          |
| TIMESTAMP      | VARCHAR(32)                       | Timestamp for the specification of the object (character data)                                                                                                                            |
| STATUS         | VARCHAR(32)                       | Status of the object: the value in ( VALID, INVALID, N/A )                                                                                                                                |
| TEMPORARY      | VARCHAR(1)                        | Indicates whether the object is temporary (the current session can see only data that it placed in this object itself) (Y) or not (N)                                                     |
| GENERATED      | VARCHAR(1)                        | <ul style="list-style-type: none"> <li>reserved</li> </ul> Indicates whether the name of this object was system-generated (Y) or not (N)                                                  |
| SECONDARY      | VARCHAR(1)                        | <ul style="list-style-type: none"> <li>reserved</li> </ul> Indicates whether this is a secondary object created by the ODCIIndexCreate method of the Oracle Data Cartridge (Y) or not (N) |
| NAMESPACE      | NUMBER                            | Namespace for the object                                                                                                                                                                  |
| EDITION_NAME   | VARCHAR(128)                      | <ul style="list-style-type: none"> <li>reserved</li> </ul> Name of the edition in which the object is actual                                                                              |
| DROPPED        | VARCHAR(3)                        | Indicates whether the object has been dropped and is in the recycle bin (YES) or not (NO)                                                                                                 |

## ALL\_PACKAGE\_PRIVS

ALL\_PACKAGE\_PRIVS describes the package grants, for which the current user is the package owner, grantor, or grantee, or for which an enabled role or PUBLIC is the grantee.

**Table 9-22** Column information

| Column name      | Data type    | Description                                                                         |
|------------------|--------------|-------------------------------------------------------------------------------------|
| GRANTOR          | VARCHAR(128) | Name of the user who performed the grant                                            |
| GRANTEE          | VARCHAR(128) | Name of the user or role to whom access was granted                                 |
| PROCEDURE_OWNER  | VARCHAR(128) | Owner of the package                                                                |
| PROCEDURE_SCHEMA | VARCHAR(128) | Schema of the package                                                               |
| PROCEDURE_NAME   | VARCHAR(128) | Name of the package                                                                 |
| PRIVILEGE        | VARCHAR(32)  | Privilege on the package                                                            |
| GRANTABLE        | VARCHAR(3)   | Indicates whether the privilege was granted with the GRANT OPTION (YES) or not (NO) |

## ALL\_PACKAGE\_PRIVS\_MADE

ALL\_PACKAGE\_PRIVS\_MADE describes the package grants for which the current user is the package owner or grantor.

**Table 9-23** Column information

| Column name      | Data type    | Description                                                                         |
|------------------|--------------|-------------------------------------------------------------------------------------|
| GRANTOR          | VARCHAR(128) | Name of the user who performed the grant                                            |
| GRANTEE          | VARCHAR(128) | Name of the user or role to whom access was granted                                 |
| PROCEDURE_OWNER  | VARCHAR(128) | Owner of the package                                                                |
| PROCEDURE_SCHEMA | VARCHAR(128) | Schema of the package                                                               |
| PROCEDURE_NAME   | VARCHAR(128) | Name of the package                                                                 |
| PRIVILEGE        | VARCHAR(32)  | Privilege on the package                                                            |
| GRANTABLE        | VARCHAR(3)   | Indicates whether the privilege was granted with the GRANT OPTION (YES) or not (NO) |

## ALL\_PACKAGE\_PRIVS\_REC'D

ALL\_PACKAGE\_PRIVS\_REC'D describes the package grants, for which the current user is the grantee, or for which an enabled role or PUBLIC is the grantee.

**Table 9-24** Column information

| Column name      | Data type    | Description                                                                         |
|------------------|--------------|-------------------------------------------------------------------------------------|
| GRANTOR          | VARCHAR(128) | Name of the user who performed the grant                                            |
| GRANTEE          | VARCHAR(128) | Name of the user or role to whom access was granted                                 |
| PROCEDURE_OWNER  | VARCHAR(128) | Owner of the package                                                                |
| PROCEDURE_SCHEMA | VARCHAR(128) | Schema of the package                                                               |
| PROCEDURE_NAME   | VARCHAR(128) | Name of the package                                                                 |
| PRIVILEGE        | VARCHAR(32)  | Privilege on the package                                                            |
| GRANTABLE        | VARCHAR(3)   | Indicates whether the privilege was granted with the GRANT OPTION (YES) or not (NO) |

## ALL\_PROCEDURES

ALL\_PROCEDURES lists all function, procedures or pacakage

**Table 9-25** Column information

| Column name    | Data type    | Description                                                                                             |
|----------------|--------------|---------------------------------------------------------------------------------------------------------|
| OWNER          | VARCHAR(128) | Owner of function, procedures or pacakage                                                               |
| SCHEMA_NAME    | VARCHAR(128) | Schema Name of function, procedures or package                                                          |
| OBJECT_NAME    | VARCHAR(128) | Name of function, procedures or pacakage                                                                |
| PROCEDURE_NAME | VARCHAR(128) | Name when a procedures in pacakage                                                                      |
| OBJECT_ID      | NUMBER       | ID of a function, procedures or pacakage                                                                |
| SUBPROGRAM_ID  | NUMBER       | ID of procedures in pacakage                                                                            |
| OVERLOAD       | VARCHAR(32)  | ID of overloading procedure in pacakage                                                                 |
| OBJECT_TYPE    | VARCHAR(32)  | Type of function, procedures or package                                                                 |
| AGGREGATE      | VARCHAR(3)   | Indicate whether the procedure is an aggreage function(YES) or not (NO)                                 |
| PIPELINED      | VARCHAR(3)   | Indicate whether the procedure is a pipelined table function(YES) or not(NO)                            |
| IMPLTYPEOWNER  | VARCHAR(128) | Name of the owner of the implementation type, if any                                                    |
| IMPLTYPENAME   | VARCHAR(128) | Name of the implementation type, if any                                                                 |
| PARALLEL       | VARCHAR(3)   | Indicates whether the procedure or function is parallel-enabled (YES ) or not (NO)                      |
| INTERFACE      | VARCHAR(3)   | YES, if the procedure/function is a table function implemented using the SQLCLI interface; otherwise NO |
| DETERMINISTIC  | VARCHAR(3)   | YES, if the procedure/function is declared to be deterministic; otherwise NO                            |
| AUTHID         | VARCHAR(32)  | Indicates whether the procedure/function is declared to execute as DEFINER or CURRENT_USER (invoker)    |

## ALL\_PROC\_PRIVS

ALL\_PROC\_PRIVS describes the procedure grants, for which the current user is the procedure owner, grantor, or grantee, or for which an enabled role or PUBLIC is the grantee.

**Table 9-26** Column information

| Column name      | Data type    | Description                                                                         |
|------------------|--------------|-------------------------------------------------------------------------------------|
| GRANTOR          | VARCHAR(128) | Name of the user who performed the grant                                            |
| GRANTEE          | VARCHAR(128) | Name of the user or role to whom access was granted                                 |
| PROCEDURE_OWNER  | VARCHAR(128) | Owner of the procedure and function                                                 |
| PROCEDURE_SCHEMA | VARCHAR(128) | Schema of the procedure and function                                                |
| PROCEDURE_NAME   | VARCHAR(128) | Name of the procedure and function                                                  |
| PRIVILEGE        | VARCHAR(32)  | Privilege on the procedure and function                                             |
| GRANTABLE        | VARCHAR(3)   | Indicates whether the privilege was granted with the GRANT OPTION (YES) or not (NO) |

## ALL\_PROC\_PRIVS\_MADE

ALL\_PROC\_PRIVS\_MADE describes the procedure grants for which the current user is the procedure owner or grantor.

**Table 9-27** Column information

| Column name      | Data type    | Description                                                                         |
|------------------|--------------|-------------------------------------------------------------------------------------|
| GRANTOR          | VARCHAR(128) | Name of the user who performed the grant                                            |
| GRANTEE          | VARCHAR(128) | Name of the user or role to whom access was granted                                 |
| PROCEDURE_OWNER  | VARCHAR(128) | Owner of the procedure and function                                                 |
| PROCEDURE_SCHEMA | VARCHAR(128) | Schema of the procedure and function                                                |
| PROCEDURE_NAME   | VARCHAR(128) | Name of the procedure and function                                                  |
| PRIVILEGE        | VARCHAR(32)  | Privilege on the procedure and function                                             |
| GRANTABLE        | VARCHAR(3)   | Indicates whether the privilege was granted with the GRANT OPTION (YES) or not (NO) |



## ALL\_PROC\_PRIVS\_REC'D

ALL\_PROC\_PRIVS\_REC'D describes the procedure grants, for which the current user is the grantee, or for which an enabled role or PUBLIC is the grantee.

**Table 9-28** Column information

| Column name      | Data type    | Description                                                                         |
|------------------|--------------|-------------------------------------------------------------------------------------|
| GRANTOR          | VARCHAR(128) | Name of the user who performed the grant                                            |
| GRANTEE          | VARCHAR(128) | Name of the user or role to whom access was granted                                 |
| PROCEDURE_OWNER  | VARCHAR(128) | Owner of the procedure and function                                                 |
| PROCEDURE_SCHEMA | VARCHAR(128) | Schema of the procedure and function                                                |
| PROCEDURE_NAME   | VARCHAR(128) | Name of the procedure and function                                                  |
| PRIVILEGE        | VARCHAR(32)  | Privilege on the procedure and function                                             |
| GRANTABLE        | VARCHAR(3)   | Indicates whether the privilege was granted with the GRANT OPTION (YES) or not (NO) |

## ALL\_SCHEMAS

Identify the schemata in a catalog that are owned by given user or accessible to given user or role.

**Table 9-29** Column information

| Column name   | Data type                      | Description                      |
|---------------|--------------------------------|----------------------------------|
| SCHEMA_OWNER  | VARCHAR(128)                   | Owner of the schema              |
| SCHEMA_NAME   | VARCHAR(128)                   | Name of the schema               |
| CREATED_TIME  | TIMESTAMP(2) WITHOUT TIME ZONE | Created time of the schema       |
| MODIFIED_TIME | TIMESTAMP(2) WITHOUT TIME ZONE | Last modified time of the schema |
| COMMENTS      | VARCHAR(1024)                  | Comments of the schema           |

## ALL\_SCHEMA\_PATH

ALL\_SCHEMA\_PATH describes the schema search order of the current user and PUBLIC, for naming resolution of unqualified SQL schema objects.

**Table 9-30** Column information

| Column name  | Data type    | Description                              |
|--------------|--------------|------------------------------------------|
| AUTH_NAME    | VARCHAR(128) | Name of the authorization                |
| SCHEMA_NAME  | VARCHAR(128) | Name of the schema                       |
| SEARCH_ORDER | NUMBER       | Schema search order of the authorization |

## ALL\_SCHEMA\_PRIVS

ALL\_SCHEMA\_PRIVS describes the schema grants, for which the current user is the schema owner, grantor, or grantee, or for which an enabled role or PUBLIC is the grantee.

**Table 9-31** Column information

| Column name | Data type    | Description                                                                         |
|-------------|--------------|-------------------------------------------------------------------------------------|
| GRANTOR     | VARCHAR(128) | Name of the user who performed the grant                                            |
| GRANTEE     | VARCHAR(128) | Name of the user or role to whom access was granted                                 |
| OWNER       | VARCHAR(128) | Owner of the schema                                                                 |
| SCHEMA_NAME | VARCHAR(128) | Name of the schema                                                                  |
| PRIVILEGE   | VARCHAR(32)  | Privilege on the schema                                                             |
| GRANTABLE   | VARCHAR(3)   | Indicates whether the privilege was granted with the GRANT OPTION (YES) or not (NO) |

## ALL\_SCHEMA\_PRIVS\_MADE

ALL\_SCHEMA\_PRIVS\_MADE describes the schema grants, for which the current user is the grantor.

**Table 9-32** Column information

| Column name | Data type    | Description                                                                         |
|-------------|--------------|-------------------------------------------------------------------------------------|
| GRANTOR     | VARCHAR(128) | Name of the user who performed the grant                                            |
| GRANTEE     | VARCHAR(128) | Name of the user or role to whom access was granted                                 |
| OWNER       | VARCHAR(128) | Owner of the schema                                                                 |
| SCHEMA_NAME | VARCHAR(128) | Name of the schema                                                                  |
| PRIVILEGE   | VARCHAR(32)  | Privilege on the schema                                                             |
| GRANTABLE   | VARCHAR(3)   | Indicates whether the privilege was granted with the GRANT OPTION (YES) or not (NO) |

## ALL\_SCHEMA\_PRIVS\_RECD

ALL\_SCHEMA\_PRIVS\_RECD describes the schema grants, for which the current user is the grantee, or for which an enabled role or PUBLIC is the grantee.

**Table 9-33** Column information

| Column name | Data type    | Description                                                                         |
|-------------|--------------|-------------------------------------------------------------------------------------|
| GRANTOR     | VARCHAR(128) | Name of the user who performed the grant                                            |
| GRANTEE     | VARCHAR(128) | Name of the user or role to whom access was granted                                 |
| OWNER       | VARCHAR(128) | Owner of the schema                                                                 |
| SCHEMA_NAME | VARCHAR(128) | Name of the schema                                                                  |
| PRIVILEGE   | VARCHAR(32)  | Privilege on the schema                                                             |
| GRANTABLE   | VARCHAR(3)   | Indicates whether the privilege was granted with the GRANT OPTION (YES) or not (NO) |

## ALL\_SEQUENCES

ALL\_SEQUENCES describes all sequences accessible to the current user.

**Table 9-34** Column information

| Column name     | Data type     | Description                                                                                                                                           |
|-----------------|---------------|-------------------------------------------------------------------------------------------------------------------------------------------------------|
| SEQUENCE_OWNER  | VARCHAR(128)  | Owner of the sequence                                                                                                                                 |
| SEQUENCE_SCHEMA | VARCHAR(128)  | Schema of the sequence                                                                                                                                |
| SEQUENCE_NAME   | VARCHAR(128)  | Sequence name                                                                                                                                         |
| MIN_VALUE       | NUMBER        | Minimum value of the sequence                                                                                                                         |
| MAX_VALUE       | NUMBER        | Maximum value of the sequence                                                                                                                         |
| INCREMENT_BY    | NUMBER        | Value by which sequence is incremented                                                                                                                |
| CYCLE_FLAG      | VARCHAR(1)    | Indicates whether the sequence wraps around on reaching the limit (Y) or not (N)                                                                      |
| ORDER_FLAG      | VARCHAR(1)    | Indicates whether sequence numbers are generated in order (Y) or not (N)                                                                              |
| CACHE_SIZE      | NUMBER        | Number of sequence numbers to cache                                                                                                                   |
| LAST_NUMBER     | NUMBER        | Last sequence number written to database. If a sequence uses caching, the number written to database is the last number placed in the sequence cache. |
| COMMENTS        | VARCHAR(1024) | Comments of the sequence                                                                                                                              |

## ALL\_SEQ\_PRIVS

ALL\_SEQ\_PRIVS describes the sequence grants, for which the current user is the sequence owner, grantor, or grantee, or for which an enabled role or PUBLIC is the grantee.

**Table 9-35** Column information

| Column name     | Data type    | Description                                                                         |
|-----------------|--------------|-------------------------------------------------------------------------------------|
| GRANTOR         | VARCHAR(128) | Name of the user who performed the grant                                            |
| GRANTEE         | VARCHAR(128) | Name of the user or role to whom access was granted                                 |
| SEQUENCE_OWNER  | VARCHAR(128) | Owner of the sequence                                                               |
| SEQUENCE_SCHEMA | VARCHAR(128) | Schema of the sequence                                                              |
| SEQUENCE_NAME   | VARCHAR(128) | Name of the sequence                                                                |
| PRIVILEGE       | VARCHAR(32)  | Privilege on the sequence                                                           |
| GRANTABLE       | VARCHAR(3)   | Indicates whether the privilege was granted with the GRANT OPTION (YES) or not (NO) |



## ALL\_SEQ\_PRIVS\_MADE

ALL\_SEQ\_PRIVS\_MADE describes the sequence grants for which the current user is the sequence owner or grantor.

**Table 9-36** Column information

| Column name         | Data type    | Description                                                                         |
|---------------------|--------------|-------------------------------------------------------------------------------------|
| GRANTOR             | VARCHAR(128) | Name of the user who performed the grant                                            |
| GRANTEE             | VARCHAR(128) | Name of the user or role to whom access was granted                                 |
| SEQUENCE_OWNER      | VARCHAR(128) | Owner of the sequence                                                               |
| SEQUENCE_SCHEM<br>A | VARCHAR(128) | Schema of the sequence                                                              |
| SEQUENCE_NAME       | VARCHAR(128) | Name of the sequence                                                                |
| PRIVILEGE           | VARCHAR(32)  | Privilege on the sequence                                                           |
| GRANTABLE           | VARCHAR(3)   | Indicates whether the privilege was granted with the GRANT OPTION (YES) or not (NO) |

## ALL\_SEQ\_PRIVS\_RECD

ALL\_SEQ\_PRIVS\_RECD describes the sequence grants, for which the current user is the grantee, or for which an enabled role or PUBLIC is the grantee.

**Table 9-37** Column information

| Column name     | Data type    | Description                                                                         |
|-----------------|--------------|-------------------------------------------------------------------------------------|
| GRANTOR         | VARCHAR(128) | Name of the user who performed the grant                                            |
| GRANTEE         | VARCHAR(128) | Name of the user or role to whom access was granted                                 |
| SEQUENCE_OWNER  | VARCHAR(128) | Owner of the sequence                                                               |
| SEQUENCE_SCHEMA | VARCHAR(128) | Schema of the sequence                                                              |
| SEQUENCE_NAME   | VARCHAR(128) | Name of the sequence                                                                |
| PRIVILEGE       | VARCHAR(32)  | Privilege on the sequence                                                           |
| GRANTABLE       | VARCHAR(3)   | Indicates whether the privilege was granted with the GRANT OPTION (YES) or not (NO) |

## ALL\_SHARD\_KEY\_COLUMNS

ALL\_SHARD\_KEY\_COLUMNS describes shard key columns of all shared tables accessible to the current user in the cluster system.



It is available only on a cluster.

**Table 9-38** Column information

| Column name     | Data type    | Description                                 |
|-----------------|--------------|---------------------------------------------|
| OWNER           | VARCHAR(128) | Owner of the table                          |
| TABLE_SCHEMA    | VARCHAR(128) | Schema of the table                         |
| TABLE_NAME      | VARCHAR(128) | Name of the table                           |
| COLUMN_NAME     | VARCHAR(128) | Column name of the shard key                |
| COLUMN_POSITION | NUMBER       | Position of the column within the shard key |

## ALL\_SOURCE

ALL\_SOURCE describes the text source of the stored objects accessible to the current user.

**Table 9-39** Column information

| Column name   | Data type    | Description                                                         |
|---------------|--------------|---------------------------------------------------------------------|
| OWNER         | VARCHAR(128) | Owner of object                                                     |
| SCHEMA_NAME   | VARCHAR(128) | Schema Name of object                                               |
| NAME          | VARCHAR(128) | Name of object                                                      |
| TYPE          | VARCHAR(32)  | Type of object: FUNCTION, PROCEDURE, PACKAGE, PACKAGE BODY, TRIGGER |
| LINE          | NUMBER       | Line number of this line of source                                  |
| TEXT          | LONG VARCHAR | Text source of the stored object                                    |
| ORIGIN_CON_ID | VARCHAR(256) | ID of the container where the data originates                       |

## ALL\_SYNONYMS

ALL\_SYNONYMS describes all synonyms.

**Table 9-40** Column information

| Column name        | Data type    | Description             |
|--------------------|--------------|-------------------------|
| SYNONYM_OWNER      | VARCHAR(128) | Owner of the synonym    |
| SYNONYM_SCHEMA     | VARCHAR(128) | Schema of the synonym   |
| SYNONYM_NAME       | VARCHAR(128) | Synonym name            |
| OBJECT_SCHEMA_NAME | VARCHAR(128) | Object schema name      |
| OBJECT_NAME        | VARCHAR(128) | Object name             |
| DB_LINK            | VARCHAR(128) | Reserved for future use |

## ALL\_TABLES

ALL\_TABLES describes the relational tables accessible to the current user.

**Table 9-41** Column information

| Column name     | Data type    | Description                                                                                                                                                               |
|-----------------|--------------|---------------------------------------------------------------------------------------------------------------------------------------------------------------------------|
| OWNER           | VARCHAR(128) | Owner of the table                                                                                                                                                        |
| TABLE_SCHEMA    | VARCHAR(128) | Schema of the table                                                                                                                                                       |
| TABLE_NAME      | VARCHAR(128) | Name of the table                                                                                                                                                         |
| TABLESPACE_NAME | VARCHAR(128) | Name of the tablespace containing the table                                                                                                                               |
| CLUSTER_NAME    | VARCHAR(128) | <ul style="list-style-type: none"> <li>reserved</li> </ul> Name of the cluster                                                                                            |
| IOT_NAME        | VARCHAR(128) | <ul style="list-style-type: none"> <li>reserved</li> </ul> Name of the index-organized table                                                                              |
| STATUS          | VARCHAR(32)  | <ul style="list-style-type: none"> <li>reserved</li> </ul> If a previous DROP TABLE operation failed, indicates whether the table is unusable (UNUSABLE) or valid (VALID) |
| PCT_FREE        | NUMBER       | Minimum percentage of free space in a block                                                                                                                               |
| PCT_USED        | NUMBER       | Minimum percentage of used space in a block                                                                                                                               |
| INI_TRANS       | NUMBER       | Initial number of transactions                                                                                                                                            |
| MAX_TRANS       | NUMBER       | Maximum number of transactions                                                                                                                                            |
| INITIAL_EXTENT  | NUMBER       | Size of the initial extent (in bytes)                                                                                                                                     |
| NEXT_EXTENT     | NUMBER       | Size of secondary extents (in bytes)                                                                                                                                      |
| MIN_EXTENTS     | NUMBER       | Minimum number of extents allowed in the segment                                                                                                                          |
| MAX_EXTENTS     | NUMBER       | Maximum number of extents allowed in the segment                                                                                                                          |
| PCT_INCREASE    | NUMBER       | <ul style="list-style-type: none"> <li>reserved</li> </ul> Percentage increase in extent size                                                                             |
| FREELISTS       | NUMBER       | <ul style="list-style-type: none"> <li>reserved</li> </ul> Number of process freelists allocated to the segment                                                           |
| FREELIST_GROUPS | NUMBER       | <ul style="list-style-type: none"> <li>reserved</li> </ul> Number of freelist groups allocated to the segment                                                             |
| LOGGING         | VARCHAR(3)   | Indicates whether or not changes to the table are logged                                                                                                                  |
| BACKED_UP       | VARCHAR(1)   | <ul style="list-style-type: none"> <li>reserved</li> </ul> Indicates whether the table has been backed up since the last modification (Y) or not (N)                      |
| NUM_ROWS        | NUMBER       | Number of rows in the table                                                                                                                                               |
| BLOCKS          | NUMBER       | Number of used blocks in the table                                                                                                                                        |
| EMPTY_BLOCKS    | NUMBER       | <ul style="list-style-type: none"> <li>reserved</li> </ul> Number of empty (never used) blocks in the table                                                               |
| AVG_SPACE       | NUMBER       | <ul style="list-style-type: none"> <li>reserved</li> </ul> Average available free space in the table                                                                      |
|                 |              | <ul style="list-style-type: none"> <li>reserved</li> </ul>                                                                                                                |

| Column name               | Data type                       | Description                                                                                                                                                  |
|---------------------------|---------------------------------|--------------------------------------------------------------------------------------------------------------------------------------------------------------|
| CHAIN_CNT                 | NUMBER                          | Number of rows in the table that are chained from one data block to another or that have migrated to a new block, requiring a link to preserve the old rowid |
| AVG_ROW_LEN               | NUMBER                          | <ul style="list-style-type: none"> <li>reserved</li> </ul> Average row length, including row overhead                                                        |
| AVG_SPACE_FREELIST_BLOCKS | NUMBER                          | <ul style="list-style-type: none"> <li>reserved</li> </ul> Average freespace of all blocks on a freelist                                                     |
| NUM_FREELIST_BLOCKS       | NUMBER                          | <ul style="list-style-type: none"> <li>reserved</li> </ul> Number of blocks on the freelist                                                                  |
| DEGREE                    | VARCHAR(32)                     | <ul style="list-style-type: none"> <li>reserved</li> </ul> Number of threads per instance for scanning the table, or DEFAULT                                 |
| INSTANCES                 | VARCHAR(32)                     | <ul style="list-style-type: none"> <li>reserved</li> </ul> Number of instances across which the table is to be scanned, or DEFAULT                           |
| CACHE                     | VARCHAR(1)                      | <ul style="list-style-type: none"> <li>reserved</li> </ul> Indicates whether the table is to be cached in the buffer cache (Y) or not (N)                    |
| TABLE_LOCK                | VARCHAR(32)                     | Indicates whether table locking is enabled (ENABLED) or disabled (DISABLED)                                                                                  |
| SAMPLE_SIZE               | NUMBER                          | Sample size used in analyzing the table                                                                                                                      |
| LAST_ANALYZED             | TIMESTAMP(6) WITH OUT TIME ZONE | Date on which the table was most recently analyzed                                                                                                           |
| PARTITIONED               | VARCHAR(3)                      | <ul style="list-style-type: none"> <li>reserved</li> </ul> Indicates whether the table is partitioned (YES) or not (NO)                                      |
| IOT_TYPE                  | VARCHAR(32)                     | <ul style="list-style-type: none"> <li>reserved</li> </ul> If the table is an index-organized table, then IOT_TYPE is IOT, IOT_OVERFLOW, or IOT_MAPPING.     |
| TEMPORARY                 | VARCHAR(1)                      | Indicates whether the table is temporary (Y) or not (N)                                                                                                      |
| SECONDARY                 | VARCHAR(1)                      | <ul style="list-style-type: none"> <li>reserved</li> </ul> Indicates whether the table is a secondary object created by cartridge                            |
| NESTED                    | VARCHAR(3)                      | <ul style="list-style-type: none"> <li>reserved</li> </ul> Indicates whether the table is a nested table (YES) or not (NO)                                   |
| BUFFER_POOL               | VARCHAR(32)                     | <ul style="list-style-type: none"> <li>reserved</li> </ul> Buffer pool to be used for table blocks                                                           |
| FLASH_CACHE               | VARCHAR(32)                     | <ul style="list-style-type: none"> <li>reserved</li> </ul> Database Smart Flash Cache hint to be used for table blocks                                       |
| CELL_FLASH_CACHE          | VARCHAR(32)                     | <ul style="list-style-type: none"> <li>reserved</li> </ul> Cell flash cache hint to be used for table blocks                                                 |
| ROW_MOVEMENT              | VARCHAR(32)                     | <ul style="list-style-type: none"> <li>reserved</li> </ul> If a partitioned table, indicates whether row movement is enabled                                 |

| Column name     | Data type    | Description                                                                                                                                                                              |
|-----------------|--------------|------------------------------------------------------------------------------------------------------------------------------------------------------------------------------------------|
|                 |              | (ENABLED) or disabled (DISABLED)                                                                                                                                                         |
| GLOBAL_STATS    | VARCHAR(3)   | <ul style="list-style-type: none"> <li>reserved</li> </ul> For partitioned tables, indicates whether statistics for the table as a whole (global statistics) are accurate (YES)          |
| USER_STATS      | VARCHAR(3)   | <ul style="list-style-type: none"> <li>reserved</li> </ul> Indicates whether statistics were entered directly by the user (YES) or not (NO)                                              |
| DURATION        | VARCHAR(32)  | Indicates the duration of a temporary table, the value is in ( TRANSACTION, SESSION )                                                                                                    |
| SKIP_CORRUPT    | VARCHAR(32)  | <ul style="list-style-type: none"> <li>reserved</li> </ul> Indicates whether Database ignores blocks marked corrupt during table and index scans (ENABLED) or raises an error (DISABLED) |
| MONITORING      | VARCHAR(3)   | <ul style="list-style-type: none"> <li>reserved</li> </ul> Indicates whether the table has the MONITORING attribute set (YES) or not (NO)                                                |
| CLUSTER_OWNER   | VARCHAR(128) | <ul style="list-style-type: none"> <li>reserved</li> </ul> Owner of the cluster, if any                                                                                                  |
| DEPENDENCIES    | VARCHAR(32)  | <ul style="list-style-type: none"> <li>reserved</li> </ul> Indicates whether row-level dependency tracking is enabled (ENABLED) or disabled (DISABLED)                                   |
| COMPRESSION     | VARCHAR(32)  | <ul style="list-style-type: none"> <li>reserved</li> </ul> Indicates whether table compression is enabled (ENABLED) or not (DISABLED)                                                    |
| COMPRESS_FOR    | VARCHAR(32)  | <ul style="list-style-type: none"> <li>reserved</li> </ul> Default compression for what kind of operations                                                                               |
| DROPPED         | VARCHAR(3)   | Indicates whether the table has been dropped and is in the recycle bin (YES) or not (NO)                                                                                                 |
| READ_ONLY       | VARCHAR(3)   | Indicates whether the table IS READ-ONLY (YES) or not (NO)                                                                                                                               |
| SEGMENT_CREATED | VARCHAR(3)   | Indicates whether the table segment has been created (YES) or not (NO)                                                                                                                   |
| RESULT_CACHE    | VARCHAR(32)  | <ul style="list-style-type: none"> <li>reserved</li> </ul> Result cache mode annotation for the table: the value is in ( NULL, DEFAULT, FORCE, MANUAL )                                  |



## ALL\_TAB\_COLS

ALL\_TAB\_COLS describes the columns(including hidden columns) of the tables, views, and clusters accessible to the current user.

**Table 9-42** Column information

| Column name          | Data type                          | Description                                                                                                                                                                                                     |
|----------------------|------------------------------------|-----------------------------------------------------------------------------------------------------------------------------------------------------------------------------------------------------------------|
| OWNER                | VARCHAR(128)                       | Owner of the object                                                                                                                                                                                             |
| TABLE_SCHEMA         | VARCHAR(128)                       | Schema of the object                                                                                                                                                                                            |
| TABLE_NAME           | VARCHAR(128)                       | Name of the object                                                                                                                                                                                              |
| COLUMN_NAME          | VARCHAR(128)                       | Column name                                                                                                                                                                                                     |
| DATA_TYPE            | VARCHAR(128)                       | Datatype of the column                                                                                                                                                                                          |
| DATA_TYPE_MOD        | VARCHAR(3)                         | <ul style="list-style-type: none"> <li>reserved</li> </ul> Datatype modifier of the column                                                                                                                      |
| DATA_TYPE_OWNER      | VARCHAR(128)                       | <ul style="list-style-type: none"> <li>reserved</li> </ul> Owner of the datatype of the column                                                                                                                  |
| DATA_LENGTH          | NUMBER                             | Length of the column (in bytes)                                                                                                                                                                                 |
| DATA_PRECISION       | NUMBER                             | Decimal precision for NUMBER datatype; binary precision for FLOAT datatype; NULL for all other datatypes                                                                                                        |
| DATA_SCALE           | NUMBER                             | Digits to the right of the decimal point in a number                                                                                                                                                            |
| NULLABLE             | VARCHAR(1)                         | Indicates whether a column allows NULLs.                                                                                                                                                                        |
| COLUMN_ID            | NUMBER                             | Sequence number of the column as created                                                                                                                                                                        |
| DEFAULT_LENGTH       | NUMBER                             | Length of the default value for the column                                                                                                                                                                      |
| DATA_DEFAULT         | LONG VARCHAR                       | Default value for the column                                                                                                                                                                                    |
| NUM_DISTINCT         | NUMBER                             | Number of distinct values in the column                                                                                                                                                                         |
| LOW_VALUE            | VARBINARY(32)                      | Low value in the column                                                                                                                                                                                         |
| HIGH_VALUE           | VARBINARY(32)                      | High value in the column                                                                                                                                                                                        |
| DENSITY              | NUMBER                             | <ul style="list-style-type: none"> <li>reserved</li> </ul> If a histogram is available on COLUMN_NAME, then this column displays the selectivity of a value that spans fewer than 2 endpoints in the histogram. |
| NUM_NULLS            | NUMBER                             | Number of NULLs in the column                                                                                                                                                                                   |
| NUM_BUCKETS          | NUMBER                             | <ul style="list-style-type: none"> <li>reserved</li> </ul> Number of buckets in the histogram for the column                                                                                                    |
| LAST_ANALYZED        | TIMESTAMP(6) WITH<br>OUT TIME ZONE | Date on which this column was most recently analyzed                                                                                                                                                            |
| SAMPLE_SIZE          | NUMBER                             | Sample size used in analyzing this column                                                                                                                                                                       |
| CHARACTER_SET_NAME   | VARCHAR(128)                       | <ul style="list-style-type: none"> <li>reserved</li> </ul> Name of the character set                                                                                                                            |
| CHAR_COL_DECL_LENGTH | NUMBER                             | <ul style="list-style-type: none"> <li>reserved</li> </ul> Declaration length of the character type column                                                                                                      |
|                      |                                    | <ul style="list-style-type: none"> <li>reserved</li> </ul>                                                                                                                                                      |

| Column name           | Data type     | Description                                                                                                                                                        |
|-----------------------|---------------|--------------------------------------------------------------------------------------------------------------------------------------------------------------------|
| GLOBAL_STATS          | VARCHAR(3)    | For partitioned tables, indicates whether column statistics were collected for the table                                                                           |
| USER_STATS            | VARCHAR(3)    | <ul style="list-style-type: none"> <li>reserved</li> </ul> Indicates whether statistics were entered directly by the user (YES) or not (NO)                        |
| AVG_COL_LEN           | NUMBER        | Average length of the column (in bytes)                                                                                                                            |
| CHAR_LENGTH           | NUMBER        | Displays the length of the column in characters.                                                                                                                   |
| CHAR_USED             | VARCHAR(1)    | Indicates that the column uses BYTE length semantics (B) or CHAR length semantics (C)                                                                              |
| V80_FMT_IMAGE         | VARCHAR(3)    | <ul style="list-style-type: none"> <li>reserved</li> </ul> Indicates whether the column data is in release older image format (YES) or not (NO)                    |
| DATA_UPGRADED         | VARCHAR(3)    | <ul style="list-style-type: none"> <li>reserved</li> </ul> Indicates whether the column data has been upgraded to the latest type version format (YES) or not (NO) |
| HIDDEN_COLUMN         | VARCHAR(3)    | Indicates whether the column is a hidden column (YES) or not (NO)                                                                                                  |
| VIRTUAL_COLUMN        | VARCHAR(3)    | <ul style="list-style-type: none"> <li>reserved</li> </ul> Indicates whether the column is a virtual column (YES) or not (NO)                                      |
| SEGMENT_COLUMN_ID     | NUMBER        | Sequence number of the column in the segment                                                                                                                       |
| INTERNAL_COLUMN_ID    | NUMBER        | Internal sequence number of the column                                                                                                                             |
| HISTOGRAM             | VARCHAR(32)   | <ul style="list-style-type: none"> <li>reserved</li> </ul> Indicates existence/type of histogram                                                                   |
| QUALIFIED_COLUMN_NAME | VARCHAR(4000) | Qualified column name                                                                                                                                              |
| IDENTITY_COLUMN       | VARCHAR(3)    | Indicates whether this is an identity column (YES) or not (NO)                                                                                                     |

## ALL\_TAB\_COLUMNS

ALL\_TAB\_COLUMNS describes the columns of the tables, views, and clusters accessible to the current user.

**Table 9-43** Column information

| Column name          | Data type                          | Description                                                                                                                                                                                                     |
|----------------------|------------------------------------|-----------------------------------------------------------------------------------------------------------------------------------------------------------------------------------------------------------------|
| OWNER                | VARCHAR(128)                       | Owner of the object                                                                                                                                                                                             |
| TABLE_SCHEMA         | VARCHAR(128)                       | Schema of the object                                                                                                                                                                                            |
| TABLE_NAME           | VARCHAR(128)                       | Name of the object                                                                                                                                                                                              |
| COLUMN_NAME          | VARCHAR(128)                       | Column name                                                                                                                                                                                                     |
| DATA_TYPE            | VARCHAR(128)                       | Datatype of the column                                                                                                                                                                                          |
| DATA_TYPE_MOD        | VARCHAR(3)                         | <ul style="list-style-type: none"> <li>reserved</li> </ul> Datatype modifier of the column                                                                                                                      |
| DATA_TYPE_OWNER      | VARCHAR(128)                       | <ul style="list-style-type: none"> <li>reserved</li> </ul> Owner of the datatype of the column                                                                                                                  |
| DATA_LENGTH          | NUMBER                             | Length of the column (in bytes)                                                                                                                                                                                 |
| DATA_PRECISION       | NUMBER                             | Decimal precision for NUMBER datatype; binary precision for FLOAT datatype; NULL for all other datatypes                                                                                                        |
| DATA_SCALE           | NUMBER                             | Digits to the right of the decimal point in a number                                                                                                                                                            |
| NULLABLE             | VARCHAR(1)                         | Indicates whether a column allows NULLs.                                                                                                                                                                        |
| COLUMN_ID            | NUMBER                             | Sequence number of the column as created                                                                                                                                                                        |
| DEFAULT_LENGTH       | NUMBER                             | Length of the default value for the column                                                                                                                                                                      |
| DATA_DEFAULT         | LONG VARCHAR                       | Default value for the column                                                                                                                                                                                    |
| NUM_DISTINCT         | NUMBER                             | Number of distinct values in the column                                                                                                                                                                         |
| LOW_VALUE            | VARBINARY(32)                      | Low value in the column                                                                                                                                                                                         |
| HIGH_VALUE           | VARBINARY(32)                      | High value in the column                                                                                                                                                                                        |
| DENSITY              | NUMBER                             | <ul style="list-style-type: none"> <li>reserved</li> </ul> If a histogram is available on COLUMN_NAME, then this column displays the selectivity of a value that spans fewer than 2 endpoints in the histogram. |
| NUM_NULLS            | NUMBER                             | Number of NULLs in the column                                                                                                                                                                                   |
| NUM_BUCKETS          | NUMBER                             | <ul style="list-style-type: none"> <li>reserved</li> </ul> Number of buckets in the histogram for the column                                                                                                    |
| LAST_ANALYZED        | TIMESTAMP(6) WITH<br>OUT TIME ZONE | Date on which this column was most recently analyzed                                                                                                                                                            |
| SAMPLE_SIZE          | NUMBER                             | Sample size used in analyzing this column                                                                                                                                                                       |
| CHARACTER_SET_NAME   | VARCHAR(128)                       | <ul style="list-style-type: none"> <li>reserved</li> </ul> Name of the character set                                                                                                                            |
| CHAR_COL_DECL_LENGTH | NUMBER                             | Declaration length of the character type column                                                                                                                                                                 |
|                      |                                    | <ul style="list-style-type: none"> <li>reserved</li> </ul>                                                                                                                                                      |

| Column name     | Data type   | Description                                                                                                                                                        |
|-----------------|-------------|--------------------------------------------------------------------------------------------------------------------------------------------------------------------|
| GLOBAL_STATS    | VARCHAR(3)  | For partitioned tables, indicates whether column statistics were collected for the table                                                                           |
| USER_STATS      | VARCHAR(3)  | <ul style="list-style-type: none"> <li>reserved</li> </ul> Indicates whether statistics were entered directly by the user (YES) or not (NO)                        |
| AVG_COL_LEN     | NUMBER      | Average length of the column (in bytes)                                                                                                                            |
| CHAR_LENGTH     | NUMBER      | Displays the length of the column in characters.                                                                                                                   |
| CHAR_USED       | VARCHAR(1)  | Indicates that the column uses BYTE length semantics (B) or CHAR length semantics (C)                                                                              |
| V80_FMT_IMAGE   | VARCHAR(3)  | <ul style="list-style-type: none"> <li>reserved</li> </ul> Indicates whether the column data is in release older image format (YES) or not (NO)                    |
| DATA_UPGRADED   | VARCHAR(3)  | <ul style="list-style-type: none"> <li>reserved</li> </ul> Indicates whether the column data has been upgraded to the latest type version format (YES) or not (NO) |
| HISTOGRAM       | VARCHAR(32) | <ul style="list-style-type: none"> <li>reserved</li> </ul> Indicates existence/type of histogram                                                                   |
| IDENTITY_COLUMN | VARCHAR(3)  | Indicates whether this is an identity column (YES) or not (NO)                                                                                                     |

## ALL\_TAB\_COMMENTS

ALL\_TAB\_COMMENTS displays comments on the tables and views accessible to the current user.

**Table 9-44** Column information

| Column name  | Data type     | Description           |
|--------------|---------------|-----------------------|
| OWNER        | VARCHAR(128)  | Owner of the object   |
| TABLE_SCHEMA | VARCHAR(128)  | Schema of the object  |
| TABLE_NAME   | VARCHAR(128)  | Name of the object    |
| TABLE_TYPE   | VARCHAR(32)   | Type of the object    |
| COMMENTS     | VARCHAR(1024) | Comment on the object |

## ALL\_TAB\_IDENTITY\_COLS

ALL\_TAB\_IDENTITY\_COLS describes all table identity columns.

**Table 9-45** Column information

| Column name      | Data type     | Description                                                                      |
|------------------|---------------|----------------------------------------------------------------------------------|
| OWNER            | VARCHAR(128)  | Owner of the table                                                               |
| TABLE_SCHEMA     | VARCHAR(128)  | Schema of the table                                                              |
| TABLE_NAME       | VARCHAR(128)  | Name of the table                                                                |
| COLUMN_NAME      | VARCHAR(128)  | Name of the identity column                                                      |
| GENERATION_TYPE  | VARCHAR(32)   | Generation type of the identity column. Possible values are ALWAYS or BY DEFAULT |
| IDENTITY_OPTIONS | VARCHAR(1024) | Options for the identity column sequence generator                               |

## ALL\_TAB\_PLACE

ALL\_TAB\_PLACE describes node placement of all cluster tables accessible to the current user in the cluster system.



It is available only on a cluster.

**Table 9-46** Column information

| Column name      | Data type                          | Description                                                                              |
|------------------|------------------------------------|------------------------------------------------------------------------------------------|
| OWNER            | VARCHAR(128)                       | Owner of the table                                                                       |
| TABLE_SCHEMA     | VARCHAR(128)                       | Schema of the table                                                                      |
| TABLE_NAME       | VARCHAR(128)                       | Name of the table                                                                        |
| GROUP_ID         | NUMBER                             | Group identifier of the node where the table placed                                      |
| GROUP_NAME       | VARCHAR(128)                       | Group name of the node where the table placed                                            |
| MEMBER_ID        | NUMBER                             | Member identifier of the node where the table placed                                     |
| MEMBER_NAME      | VARCHAR(128)                       | Member name of the node where the table placed                                           |
| MEMBER_POSITION  | NUMBER                             | Member position of the node where the table placed                                       |
| MEMBER_OFFLINE   | BOOLEAN                            | data of the cluster member is offline or not                                             |
| IS_UPDATE_MASTER | BOOLEAN                            | whether the cluster member is update master or not                                       |
| DROPPED          | VARCHAR(3)                         | Indicates whether the table has been dropped and is in the recycle bin (YES) or not (NO) |
| SCN              | VARCHAR(64)                        | table scn of the node where the table placed                                             |
| NUM_ROWS         | NUMBER                             | Number of rows in the table                                                              |
| BLOCKS           | NUMBER                             | Number of used blocks of the node where the table placed                                 |
| LAST_ANALYZED    | TIMESTAMP(6) WITH<br>OUT TIME ZONE | Date on which the table was most recently analyzed                                       |

## ALL\_TAB\_SHARDS

ALL\_TAB\_SHARDS describes shard information of sharded tables accessible to the current user in the cluster system.



It is available only on a cluster.

**Table 9-47** Column information

| Column name      | Data type    | Description                                                                                    |
|------------------|--------------|------------------------------------------------------------------------------------------------|
| OWNER            | VARCHAR(128) | Owner of the table                                                                             |
| TABLE_SCHEMA     | VARCHAR(128) | Schema of the table                                                                            |
| TABLE_NAME       | VARCHAR(128) | Name of the table                                                                              |
| SHARD_STRATEGY   | VARCHAR(32)  | Sharding strategy of the table:<br>the value in (HASH SHARDING, RANGE SHARDING, LIST SHARDING) |
| SHARD_NAME       | VARCHAR(128) | Shard name                                                                                     |
| SHARD_NUMBER     | NUMBER       | Shard number                                                                                   |
| SHARD_DEFINITION | LONG VARCHAR | Shard definition (if hash sharded, the value is null)                                          |
| GROUP_ID         | NUMBER       | Group identifier where the shard placed                                                        |
| GROUP_NAME       | VARCHAR(128) | Group Name where the shard placed                                                              |
| DROPPED          | VARCHAR(3)   | Indicates whether the table has been dropped and is in the recycle bin (YES) or not (NO)       |



## ALL\_TAB\_PRIVS

ALL\_TAB\_PRIVS describes the object grants, for which the current user is the object owner, grantor, or grantee, or for which an enabled role or PUBLIC is the grantee.

**Table 9-48** Column information

| Column name  | Data type    | Description                                                                             |
|--------------|--------------|-----------------------------------------------------------------------------------------|
| GRANTOR      | VARCHAR(128) | Name of the user who performed the grant                                                |
| GRANTEE      | VARCHAR(128) | Name of the user or role to whom access was granted                                     |
| OWNER        | VARCHAR(128) | Owner of the object                                                                     |
| TABLE_SCHEMA | VARCHAR(128) | Schema of the object                                                                    |
| TABLE_NAME   | VARCHAR(128) | Name of the object                                                                      |
| PRIVILEGE    | VARCHAR(32)  | Privilege on the object                                                                 |
| GRANTABLE    | VARCHAR(3)   | Indicates whether the privilege was granted with the GRANT OPTION (YES) or not (NO)     |
| HIERARCHY    | VARCHAR(3)   | Indicates whether the privilege was granted with the HIERARCHY OPTION (YES) or not (NO) |

## ALL\_TAB\_PRIVS\_MADE

ALL\_TAB\_PRIVS\_MADE describes the object grants for which the current user is the object owner or grantor.

**Table 9-49** Column information

| Column name  | Data type    | Description                                                                             |
|--------------|--------------|-----------------------------------------------------------------------------------------|
| GRANTEE      | VARCHAR(128) | Name of the user or role to whom access was granted                                     |
| OWNER        | VARCHAR(128) | Owner of the object                                                                     |
| TABLE_SCHEMA | VARCHAR(128) | Schema of the object                                                                    |
| TABLE_NAME   | VARCHAR(128) | Name of the object                                                                      |
| GRANTOR      | VARCHAR(128) | Name of the user who performed the grant                                                |
| PRIVILEGE    | VARCHAR(32)  | Privilege on the object                                                                 |
| GRANTABLE    | VARCHAR(3)   | Indicates whether the privilege was granted with the GRANT OPTION (YES) or not (NO)     |
| HIERARCHY    | VARCHAR(3)   | Indicates whether the privilege was granted with the HIERARCHY OPTION (YES) or not (NO) |

## ALL\_TAB\_PRIVS\_RECD

ALL\_TAB\_PRIVS\_RECD describes object grants, for which the current user is the grantee, or for which an enabled role or PUBLIC is the grantee.

**Table 9-50** Column information

| Column name  | Data type    | Description                                                                             |
|--------------|--------------|-----------------------------------------------------------------------------------------|
| GRANTEE      | VARCHAR(128) | Name of the user or role to whom access was granted                                     |
| OWNER        | VARCHAR(128) | Owner of the object                                                                     |
| TABLE_SCHEMA | VARCHAR(128) | Schema of the object                                                                    |
| TABLE_NAME   | VARCHAR(128) | Name of the object                                                                      |
| GRANTOR      | VARCHAR(128) | Name of the user who performed the grant                                                |
| PRIVILEGE    | VARCHAR(32)  | Privilege on the object                                                                 |
| GRANTABLE    | VARCHAR(3)   | Indicates whether the privilege was granted with the GRANT OPTION (YES) or not (NO)     |
| HIERARCHY    | VARCHAR(3)   | Indicates whether the privilege was granted with the HIERARCHY OPTION (YES) or not (NO) |

## ALL\_TBS\_PRIVS

ALL\_TBS\_PRIVS describes the tablespace grants, for which the current user is the grantor, or grantee, or for which an enabled role or PUBLIC is the grantee.

**Table 9-51** Column information

| Column name     | Data type    | Description                                                                         |
|-----------------|--------------|-------------------------------------------------------------------------------------|
| GRANTOR         | VARCHAR(128) | Name of the user who performed the grant                                            |
| GRANTEE         | VARCHAR(128) | Name of the user or role to whom access was granted                                 |
| TABLESPACE_NAME | VARCHAR(128) | Name of the tablespace                                                              |
| PRIVILEGE       | VARCHAR(32)  | Privilege on the tablespace                                                         |
| GRANTABLE       | VARCHAR(3)   | Indicates whether the privilege was granted with the GRANT OPTION (YES) or not (NO) |

## ALL\_TBS\_PRIVS\_MADE

ALL\_TBS\_PRIVS\_MADE describes the tablespace grants for which the current user is the grantor.

**Table 9-52** Column information

| Column name     | Data type    | Description                                                                         |
|-----------------|--------------|-------------------------------------------------------------------------------------|
| GRANTOR         | VARCHAR(128) | Name of the user who performed the grant                                            |
| GRANTEE         | VARCHAR(128) | Name of the user or role to whom access was granted                                 |
| TABLESPACE_NAME | VARCHAR(128) | Name of the tablespace                                                              |
| PRIVILEGE       | VARCHAR(32)  | Privilege on the tablespace                                                         |
| GRANTABLE       | VARCHAR(3)   | Indicates whether the privilege was granted with the GRANT OPTION (YES) or not (NO) |

## ALL\_TBS\_PRIVS\_RECD

ALL\_TBS\_PRIVS\_RECD describes the tablespace grants, for which the current user is the grantee, or for which an enabled role or PUBLIC is the grantee.

**Table 9-53** Column information

| Column name     | Data type    | Description                                                                         |
|-----------------|--------------|-------------------------------------------------------------------------------------|
| GRANTOR         | VARCHAR(128) | Name of the user who performed the grant                                            |
| GRANTEE         | VARCHAR(128) | Name of the user or role to whom access was granted                                 |
| TABLESPACE_NAME | VARCHAR(128) | Name of the tablespace                                                              |
| PRIVILEGE       | VARCHAR(32)  | Privilege on the tablespace                                                         |
| GRANTABLE       | VARCHAR(3)   | Indicates whether the privilege was granted with the GRANT OPTION (YES) or not (NO) |

## ALL\_USERS

ALL\_USERS lists all users of the database visible to the current user.

**Table 9-54** Column information

| Column name | Data type                      | Description             |
|-------------|--------------------------------|-------------------------|
| USERNAME    | VARCHAR(128)                   | Name of the user        |
| USER_ID     | NUMBER                         | ID number of the user   |
| CREATED     | TIMESTAMP(2) WITHOUT TIME ZONE | User creation timestamp |

## ALL\_VIEWS

ALL\_VIEWS describes the views accessible to the current user.

**Table 9-55** Column information

| Column name      | Data type     | Description                                                                                                          |
|------------------|---------------|----------------------------------------------------------------------------------------------------------------------|
| OWNER            | VARCHAR(128)  | Owner of the view                                                                                                    |
| VIEW_SCHEMA      | VARCHAR(128)  | Schema of the view                                                                                                   |
| VIEW_NAME        | VARCHAR(128)  | Name of the view                                                                                                     |
| TEXT_LENGTH      | NUMBER        | Length of the view text                                                                                              |
| TEXT             | LONG VARCHAR  | View text                                                                                                            |
| TYPE_TEXT_LENGTH | NUMBER        | <ul style="list-style-type: none"> <li>reserved</li> </ul> Length of the type clause of the typed view               |
| TYPE_TEXT        | VARCHAR(4000) | <ul style="list-style-type: none"> <li>reserved</li> </ul> Type clause of the typed view                             |
| OID_TEXT_LENGTH  | NUMBER        | <ul style="list-style-type: none"> <li>reserved</li> </ul> Length of the WITH OID clause of the typed view           |
| OID_TEXT         | VARCHAR(4000) | <ul style="list-style-type: none"> <li>reserved</li> </ul> WITH OID clause of the typed view                         |
| VIEW_TYPE_OWNER  | VARCHAR(128)  | <ul style="list-style-type: none"> <li>reserved</li> </ul> Owner of the type of the view if the view is a typed view |
| VIEW_TYPE        | VARCHAR(32)   | <ul style="list-style-type: none"> <li>reserved</li> </ul> Type of the view if the view is a typed view              |
| SUPERVIEW_NAME   | VARCHAR(128)  | <ul style="list-style-type: none"> <li>reserved</li> </ul> Name of the superview                                     |
| EDITIONING_VIEW  | VARCHAR(1)    | <ul style="list-style-type: none"> <li>reserved</li> </ul> Reserved for future use                                   |
| READ_ONLY        | VARCHAR(1)    | Indicates whether the view is read-only (Y) or not (N)                                                               |



## Views of DBA\_family

The current user has DBA privileges (ACCESS CONTROL ON DATABASE), and the user can retrieve information about all objects.

### DBA\_ALL\_TABLES

DBA\_ALL\_TABLES describes all object tables and relational tables in the database.

**Table 9-56** Column information

| Column name     | Data type    | Description                                                                                                                                                               |
|-----------------|--------------|---------------------------------------------------------------------------------------------------------------------------------------------------------------------------|
| OWNER           | VARCHAR(128) | Owner of the table                                                                                                                                                        |
| TABLE_SCHEMA    | VARCHAR(128) | Schema of the table                                                                                                                                                       |
| TABLE_NAME      | VARCHAR(128) | Name of the table                                                                                                                                                         |
| TABLESPACE_NAME | VARCHAR(128) | Name of the tablespace containing the table                                                                                                                               |
| CLUSTER_NAME    | VARCHAR(128) | <ul style="list-style-type: none"> <li>reserved</li> </ul> Name of the cluster                                                                                            |
| IOT_NAME        | VARCHAR(128) | <ul style="list-style-type: none"> <li>reserved</li> </ul> Name of the index-organized table                                                                              |
| STATUS          | VARCHAR(32)  | <ul style="list-style-type: none"> <li>reserved</li> </ul> If a previous DROP TABLE operation failed, indicates whether the table is unusable (UNUSABLE) or valid (VALID) |
| PCT_FREE        | NUMBER       | Minimum percentage of free space in a block                                                                                                                               |
| PCT_USED        | NUMBER       | Minimum percentage of used space in a block                                                                                                                               |
| INI_TRANS       | NUMBER       | Initial number of transactions                                                                                                                                            |
| MAX_TRANS       | NUMBER       | Maximum number of transactions                                                                                                                                            |
| INITIAL_EXTENT  | NUMBER       | Size of the initial extent (in bytes)                                                                                                                                     |
| NEXT_EXTENT     | NUMBER       | Size of secondary extents (in bytes)                                                                                                                                      |
| MIN_EXTENTS     | NUMBER       | Minimum number of extents allowed in the segment                                                                                                                          |
| MAX_EXTENTS     | NUMBER       | Maximum number of extents allowed in the segment                                                                                                                          |
| PCT_INCREASE    | NUMBER       | <ul style="list-style-type: none"> <li>reserved</li> </ul> Percentage increase in extent size                                                                             |
| FREELISTS       | NUMBER       | <ul style="list-style-type: none"> <li>reserved</li> </ul> Number of process freelists allocated to the segment                                                           |
| FREELIST_GROUPS | NUMBER       | <ul style="list-style-type: none"> <li>reserved</li> </ul> Number of freelist groups allocated to the segment                                                             |
| LOGGING         | VARCHAR(3)   | Indicates whether or not changes to the table are logged                                                                                                                  |
| BACKED_UP       | VARCHAR(1)   | <ul style="list-style-type: none"> <li>reserved</li> </ul> Indicates whether the table has been backed up since the last modification                                     |

| Column name               | Data type                         | Description                                                                                                                                                                                                             |
|---------------------------|-----------------------------------|-------------------------------------------------------------------------------------------------------------------------------------------------------------------------------------------------------------------------|
|                           |                                   | (Y) or not (N)                                                                                                                                                                                                          |
| NUM_ROWS                  | NUMBER                            | Number of rows in the table                                                                                                                                                                                             |
| BLOCKS                    | NUMBER                            | <ul style="list-style-type: none"> <li>reserved</li> </ul> Number of used blocks in the table                                                                                                                           |
| EMPTY_BLOCKS              | NUMBER                            | <ul style="list-style-type: none"> <li>reserved</li> </ul> Number of empty (never used) blocks in the table                                                                                                             |
| AVG_SPACE                 | NUMBER                            | <ul style="list-style-type: none"> <li>reserved</li> </ul> Average available free space in the table                                                                                                                    |
| CHAIN_CNT                 | NUMBER                            | <ul style="list-style-type: none"> <li>reserved</li> </ul> Number of rows in the table that are chained from one data block to another or that have migrated to a new block, requiring a link to preserve the old rowid |
| AVG_ROW_LEN               | NUMBER                            | <ul style="list-style-type: none"> <li>reserved</li> </ul> Average row length, including row overhead                                                                                                                   |
| AVG_SPACE_FREELIST_BLOCKS | NUMBER                            | <ul style="list-style-type: none"> <li>reserved</li> </ul> Average freespace of all blocks on a freelist                                                                                                                |
| NUM_FREELIST_BLOCKS       | NUMBER                            | <ul style="list-style-type: none"> <li>reserved</li> </ul> Number of blocks on the freelist                                                                                                                             |
| DEGREE                    | VARCHAR(32)                       | <ul style="list-style-type: none"> <li>reserved</li> </ul> Number of threads per instance for scanning the table, or DEFAULT                                                                                            |
| INSTANCES                 | VARCHAR(32)                       | <ul style="list-style-type: none"> <li>reserved</li> </ul> Number of instances across which the table is to be scanned, or DEFAULT                                                                                      |
| CACHE                     | VARCHAR(1)                        | <ul style="list-style-type: none"> <li>reserved</li> </ul> Indicates whether the table is to be cached in the buffer cache (Y) or not (N)                                                                               |
| TABLE_LOCK                | VARCHAR(32)                       | Indicates whether table locking is enabled (ENABLED) or disabled (DISABLED)                                                                                                                                             |
| SAMPLE_SIZE               | NUMBER                            | Sample size used in analyzing the table                                                                                                                                                                                 |
| LAST_ANALYZED             | TIMESTAMP(6)<br>WITHOUT TIME ZONE | Date on which the table was most recently analyzed                                                                                                                                                                      |
| PARTITIONED               | VARCHAR(3)                        | <ul style="list-style-type: none"> <li>reserved</li> </ul> Indicates whether the table is partitioned (YES) or not (NO)                                                                                                 |
| IOT_TYPE                  | VARCHAR(32)                       | <ul style="list-style-type: none"> <li>reserved</li> </ul> If the table is an index-organized table, then IOT_TYPE is IOT, IOT_OVERFLOW, or IOT_MAPPING.                                                                |
| OBJECT_ID_TYPE            | VARCHAR(32)                       | <ul style="list-style-type: none"> <li>reserved</li> </ul> Indicates whether the object ID (OID) is USER-DEFINED or SYSTEM GENERATED                                                                                    |
| TABLE_TYPE_OWNER          | VARCHAR(128)                      | <ul style="list-style-type: none"> <li>reserved</li> </ul> If an object table, owner of the type from which the table is created                                                                                        |

| Column name      | Data type    | Description                                                                                                                                                                              |
|------------------|--------------|------------------------------------------------------------------------------------------------------------------------------------------------------------------------------------------|
| TABLE_TYPE       | VARCHAR(128) | <ul style="list-style-type: none"> <li>reserved</li> </ul> If an object table, type of the table                                                                                         |
| TEMPORARY        | VARCHAR(1)   | Indicates whether the table is temporary (Y) or not (N)                                                                                                                                  |
| SECONDARY        | VARCHAR(1)   | <ul style="list-style-type: none"> <li>reserved</li> </ul> Indicates whether the table is a secondary object created by cartridge                                                        |
| NESTED           | VARCHAR(3)   | <ul style="list-style-type: none"> <li>reserved</li> </ul> Indicates whether the table is a nested table (YES) or not (NO)                                                               |
| BUFFER_POOL      | VARCHAR(32)  | <ul style="list-style-type: none"> <li>reserved</li> </ul> Buffer pool to be used for table blocks                                                                                       |
| FLASH_CACHE      | VARCHAR(32)  | <ul style="list-style-type: none"> <li>reserved</li> </ul> Database Smart Flash Cache hint to be used for table blocks                                                                   |
| CELL_FLASH_CACHE | VARCHAR(32)  | <ul style="list-style-type: none"> <li>reserved</li> </ul> Cell flash cache hint to be used for table blocks                                                                             |
| ROW_MOVEMENT     | VARCHAR(32)  | <ul style="list-style-type: none"> <li>reserved</li> </ul> If a partitioned table, indicates whether row movement is enabled (ENABLED) or disabled (DISABLED)                            |
| GLOBAL_STATS     | VARCHAR(3)   | <ul style="list-style-type: none"> <li>reserved</li> </ul> For partitioned tables, indicates whether statistics for the table as a whole (global statistics) are accurate (YES)          |
| USER_STATS       | VARCHAR(3)   | <ul style="list-style-type: none"> <li>reserved</li> </ul> Indicates whether statistics were entered directly by the user (YES) or not (NO)                                              |
| DURATION         | VARCHAR(32)  | Indicates the duration of a temporary table, the value is in ( TRANSACTION, SESSION )                                                                                                    |
| SKIP_CORRUPT     | VARCHAR(32)  | <ul style="list-style-type: none"> <li>reserved</li> </ul> Indicates whether Database ignores blocks marked corrupt during table and index scans (ENABLED) or raises an error (DISABLED) |
| MONITORING       | VARCHAR(3)   | <ul style="list-style-type: none"> <li>reserved</li> </ul> Indicates whether the table has the MONITORING attribute set (YES) or not (NO)                                                |
| CLUSTER_OWNER    | VARCHAR(128) | <ul style="list-style-type: none"> <li>reserved</li> </ul> Owner of the cluster, if any                                                                                                  |
| DEPENDENCIES     | VARCHAR(32)  | <ul style="list-style-type: none"> <li>reserved</li> </ul> Indicates whether row-level dependency tracking is enabled (ENABLED) or disabled (DISABLED)                                   |
| COMPRESSION      | VARCHAR(32)  | <ul style="list-style-type: none"> <li>reserved</li> </ul> Indicates whether table compression is enabled (ENABLED) or not (DISABLED)                                                    |
| COMPRESS_FOR     | VARCHAR(32)  | <ul style="list-style-type: none"> <li>reserved</li> </ul> Default compression for what kind of operations                                                                               |
|                  |              | Indicates whether the table has been dropped and is in the recycle bin (YES)                                                                                                             |

| Column name     | Data type  | Description                                                            |
|-----------------|------------|------------------------------------------------------------------------|
| DROPPED         | VARCHAR(3) | or not (NO)                                                            |
| READ_ONLY       | VARCHAR(3) | Indicates whether the table IS READ-ONLY (YES) or not (NO)             |
| SEGMENT_CREATED | VARCHAR(3) | Indicates whether the table segment has been created (YES) or not (NO) |

## DBA\_ARGUMENTS

DBA\_ARGUMENTS lists all arguments of functions, procedures.

**Table 9-57** Column information

| Column name        | Data type    | Description                                                           |
|--------------------|--------------|-----------------------------------------------------------------------|
| OWNER              | VARCHAR(128) | Owner of function, procedures or package                              |
| SCHEMA_NAME        | VARCHAR(128) | Schema Name of function, procedures or package                        |
| OBJECT_NAME        | VARCHAR(128) | Name of function, procedures                                          |
| PACKAGE_NAME       | VARCHAR(128) | Package Name of function, procedures                                  |
| OBJECT_ID          | NUMBER       | ID of a function, procedures                                          |
| SUBPROGRAM_ID      | NUMBER       | ID of procedures in package                                           |
| ARGUMENT_NAME      | VARCHAR(128) | Name of argument or attribute name of record type argument            |
| POSITION           | NUMBER       | Position of argument or position of attribute in record type          |
| SEQUENCE           | NUMBER       | Sequential order of argument and its attributes                       |
| DATA_LEVEL         | NUMBER       | Nesting depth of the argument for composite types                     |
| DATA_TYPE          | VARCHAR(128) | Data type of the argument                                             |
| DEFAULTED          | VARCHAR(1)   | Whether or not the argument is defaulted                              |
| DEFAULT_VALUE      | VARCHAR(1)   | Reserved for future use                                               |
| DEFAULT_LENGTH     | VARCHAR(1)   | Reserved for future use                                               |
| IN_OUT             | VARCHAR(32)  | Direction of the argument (IN, OUT, IN/OUT)                           |
| DATA_LENGTH        | NUMBER       | Length of the column(in bytes)                                        |
| DATA_PRECISION     | NUMBER       | Length in decimal digits(NUMBER) or binary digits(FLOAT)              |
| DATA_SCALE         | NUMBER       | Digits to the right of the decimal point in a number                  |
| RADIX              | NUMBER       | Argument radix for a number                                           |
| CHARACTER_SET_NAME | VARCHAR(128) | Character set name for the argument                                   |
| TYPE_OWNER         | VARCHAR(128) | Owner of the type of the argument                                     |
| TYPE_NAME          | VARCHAR(128) | Name of the type of the argument                                      |
| TYPE_SUBNAME       | VARCHAR(128) | Name of the type of the argument declared in package                  |
| TYPE_LINK          | VARCHAR(128) | Name of the type of the argument declared in a remote package         |
| PLS_TYPE           | VARCHAR(128) | Name of the type of the argument at PSM                               |
| CHAR_LENGTH        | NUMBER       | Character limit for string datatypes                                  |
| CHAR_USED          | VARCHAR(1)   | Whether the byte limit(B) or char limit(C) is official for the string |
| ORIGIN_CON_ID      | VARCHAR(256) | ID of the container where the data originates                         |

## DBA\_CATALOG

DBA\_CATALOG lists all tables, views, synonyms, and sequences in the database.

**Table 9-58** Column information

| Column name  | Data type    | Description                                                |
|--------------|--------------|------------------------------------------------------------|
| OWNER        | VARCHAR(128) | Owner of the TABLE, VIEW, SYNONYM, SEQUENCE, or UNDEFINED  |
| TABLE_SCHEMA | VARCHAR(128) | Schema of the TABLE, VIEW, SYNONYM, SEQUENCE, or UNDEFINED |
| TABLE_NAME   | VARCHAR(128) | Name of the TABLE, VIEW, SYNONYM, SEQUENCE, or UNDEFINED   |
| TABLE_TYPE   | VARCHAR(32)  | Type of the TABLE, VIEW, SYNONYM, SEQUENCE, or UNDEFINED   |

## DBA\_CLUSTER

DBA\_CLUSTER describes all cluster members in the cluster system.



It is available only on a cluster.

**Table 9-59** Column information

| Column name     | Data type    | Description                                  |
|-----------------|--------------|----------------------------------------------|
| GROUP_ID        | NUMBER       | Group identifier of the cluster member       |
| GROUP_NAME      | VARCHAR(128) | Group name of the cluster member             |
| MEMBER_ID       | NUMBER       | Member identifier of the cluster member      |
| MEMBER_NAME     | VARCHAR(128) | Member name of the cluster member            |
| MEMBER_HOST     | VARCHAR(128) | Host address of the cluster member           |
| MEMBER_PORT     | NUMBER       | Port number of the cluster member            |
| MEMBER_POSITION | NUMBER       | Member position number of the cluster member |

## DBA\_CLUSTER\_COMMENTS

DBA\_CLUSTER\_COMMENTS displays comments on the cluster objects in the cluster system.



It is available only on a cluster.

**Table 9-60** Column information

| Column name | Data type     | Description                                               |
|-------------|---------------|-----------------------------------------------------------|
| OBJECT_NAME | VARCHAR(128)  | Name of the cluster object                                |
| OBJECT_TYPE | VARCHAR(32)   | Type of the cluster object: CLUSTER GROUP, CLUSTER MEMBER |
| COMMENTS    | VARCHAR(1024) | Comment on the cluster object                             |



## DBA\_CLUSTER\_TABLES

DBA\_CLUSTER\_TABLES describes all cluster tables in the cluster system.



It is available only on a cluster.

**Table 9-61** Column information

| Column name     | Data type    | Description                                                                                                |
|-----------------|--------------|------------------------------------------------------------------------------------------------------------|
| OWNER           | VARCHAR(128) | Owner of the table                                                                                         |
| TABLE_SCHEMA    | VARCHAR(128) | Schema of the table                                                                                        |
| TABLE_NAME      | VARCHAR(128) | Name of the table                                                                                          |
| SHARD_STRATEGY  | VARCHAR(32)  | Sharding strategy of the table:<br>the value in (CLONED, HASH SHARDING, RANGE SHARDING, LIST S<br>HARDING) |
| SHARD_PLACEMENT | VARCHAR(32)  | Shard placement of the table:<br>the value in (AT CLUSTER WIDE or AT CLUSTER GROUP)                        |
| SHARD_COUNT     | NUMBER       | Shard count of the table (if cloned table, the value is null)                                              |
| SHARD_KEY_COUNT | NUMBER       | Shard key column count of the table (if cloned table, the value is nul<br>l)                               |
| HAS_GSI         | VARCHAR(3)   | Indicate whether the table has global secondary index: (YES) or (NO<br>)                                   |
| DROPPED         | VARCHAR(3)   | Indicates whether the table has been dropped and is in the recycle b<br>in (YES) or not (NO)               |

## DBA\_COL\_COMMENTS

DBA\_COL\_COMMENTS displays comments on the columns of all tables and views in the database.

**Table 9-62** Column information

| Column name  | Data type     | Description           |
|--------------|---------------|-----------------------|
| OWNER        | VARCHAR(128)  | Owner of the object   |
| TABLE_SCHEMA | VARCHAR(128)  | Schema of the object  |
| TABLE_NAME   | VARCHAR(128)  | Name of the object    |
| COLUMN_NAME  | VARCHAR(128)  | Name of the column    |
| COMMENTS     | VARCHAR(1024) | Comment on the column |

## DBA\_COL\_PRIVS

DBA\_COL\_PRIVS describes all column object grants in the database.

**Table 9-63** Column information

| Column name  | Data type              | Description                                                                         |
|--------------|------------------------|-------------------------------------------------------------------------------------|
| GRANTOR      | CHARACTER VARYING(128) | Name of the user who performed the grant                                            |
| GRANTEE      | CHARACTER VARYING(128) | Name of the user or role to whom access was granted                                 |
| OWNER        | CHARACTER VARYING(128) | Owner of the object                                                                 |
| TABLE_SCHEMA | CHARACTER VARYING(128) | Schema of the object                                                                |
| TABLE_NAME   | CHARACTER VARYING(128) | Name of the object                                                                  |
| COLUMN_NAME  | CHARACTER VARYING(128) | Name of the column                                                                  |
| PRIVILEGE    | CHARACTER VARYING(32)  | Privilege on the column                                                             |
| GRANTABLE    | CHARACTER VARYING(3)   | Indicates whether the privilege was granted with the GRANT OPTION (YES) or not (NO) |

## DBA\_CONSTRAINTS

DBA\_CONSTRAINTS describes all constraint definitions on all tables in the database.

**Table 9-64** Column information

| Column name       | Data type         | Description                                                                                                                                                                        |
|-------------------|-------------------|------------------------------------------------------------------------------------------------------------------------------------------------------------------------------------|
| OWNER             | VARCHAR(128)      | Owner of the constraint definition                                                                                                                                                 |
| CONSTRAINT_SCHEMA | VARCHAR(128)      | Schema of the constraint definition                                                                                                                                                |
| CONSTRAINT_NAME   | VARCHAR(128)      | Name of the constraint definition                                                                                                                                                  |
| CONSTRAINT_TYPE   | VARCHAR(1)        | Type of the constraint definition: the value in ( C: check constraint, P: Primary key, U: Unique Key, R: Referential integrity )                                                   |
| TABLE_OWNER       | VARCHAR(128)      | Owner of the table (or view) associated with the constraint definition                                                                                                             |
| TABLE_SCHEMA      | VARCHAR(128)      | Schema of the table (or view) associated with the constraint definition                                                                                                            |
| TABLE_NAME        | VARCHAR(128)      | Name of the table (or view) associated with the constraint definition                                                                                                              |
| SEARCH_CONDITION  | LONG VARCHAR      | Text of search condition for a check constraint                                                                                                                                    |
| R_OWNER           | VARCHAR(128)      | Owner of the unique constraint definition for the referenced table                                                                                                                 |
| R_SCHEMA          | VARCHAR(128)      | Schema of the unique constraint definition for the referenced table                                                                                                                |
| R_CONSTRAINT_NAME | VARCHAR(128)      | Name of the unique constraint definition for the referenced table                                                                                                                  |
| DELETE_RULE       | VARCHAR(32)       | Delete rule for a referential constraint: the value in ( NO ACTION, RESTRICT, CASCADE, SET NULL, SET DEFAULT )                                                                     |
| UPDATE_RULE       | VARCHAR(32)       | Update rule for a referential constraint: the value in ( NO ACTION, RESTRICT, CASCADE, SET NULL, SET DEFAULT )                                                                     |
| STATUS            | VARCHAR(32)       | Enforcement status of the constraint: the value in ( ENABLED, DISABLE )                                                                                                            |
| DEFERRABLE        | VARCHAR(32)       | Indicates whether the constraint is deferrable (DEFERRABLE) or not (NOT DEFERRABLE)                                                                                                |
| DEFERRED          | VARCHAR(32)       | Indicates whether the constraint was initially deferred (DEFERRED) or not (IMMEDIATE)                                                                                              |
| VALIDATED         | VARCHAR(32)       | Indicates whether all data may obey the constraint or not: the value in ( VALIDATED, NOT VALIDATED )                                                                               |
| GENERATED         | VARCHAR(32)       | Indicates whether the name of the constraint is user-generated (USER NAME) or system-generated (GENERATED NAME)                                                                    |
| BAD               | VARCHAR(32)       | <ul style="list-style-type: none"> <li>reserved</li> </ul> Indicates whether this constraint specifies a century in an ambiguous manner (BAD) or not (NULL)                        |
| RELY              | VARCHAR(32)       | <ul style="list-style-type: none"> <li>reserved</li> </ul> When NOT VALIDATED, indicates whether the constraint is to be taken into account for query rewrite (RELY) or not (NULL) |
|                   | TIMESTAMP(2) WITH |                                                                                                                                                                                    |

| Column name  | Data type     | Description                                                                                                                                  |
|--------------|---------------|----------------------------------------------------------------------------------------------------------------------------------------------|
| LAST_CHANGE  | OUT TIME ZONE | When the constraint was last enabled or disabled                                                                                             |
| INDEX_OWNER  | VARCHAR(128)  | Owner of the index associated with the key constraint                                                                                        |
| INDEX_SCHEMA | VARCHAR(128)  | Schema of the index associated with the key constraint                                                                                       |
| INDEX_NAME   | VARCHAR(128)  | Name of the index associated with the key constraint                                                                                         |
| INVALID      | VARCHAR(32)   | Indicates whether the constraint is invalid (INVALID) or not (NULL)                                                                          |
| VIEW_RELATED | VARCHAR(32)   | <ul style="list-style-type: none"> <li>reserved</li> </ul> Indicates whether the constraint depends on a view (DEPEND ON VIEW) or not (NULL) |
| DROPPED      | VARCHAR(3)    | Indicates whether the constraint has been dropped and is in the recycle bin (YES) or not (NO)                                                |
| COMMENTS     | VARCHAR(1024) | Comments of the constraint definition                                                                                                        |

## DBA\_CONS\_COLUMNS

DBA\_CONS\_COLUMNS describes all columns in the database that are specified in constraints.

**Table 9-65** Column information

| Column name       | Data type    | Description                                                                                      |
|-------------------|--------------|--------------------------------------------------------------------------------------------------|
| OWNER             | VARCHAR(128) | Owner of the constraint definition                                                               |
| CONSTRAINT_SCHEMA | VARCHAR(128) | Schema of the constraint definition                                                              |
| CONSTRAINT_NAME   | VARCHAR(128) | Name of the constraint definition                                                                |
| TABLE_OWNER       | VARCHAR(128) | Owner of the table with the constraint definition                                                |
| TABLE_SCHEMA      | VARCHAR(128) | Schema of the table with the constraint definition                                               |
| TABLE_NAME        | VARCHAR(128) | Name of the table with the constraint definition                                                 |
| COLUMN_NAME       | VARCHAR(128) | Name of the column or attribute of the object type column specified in the constraint definition |
| POSITION          | NUMBER       | Original position of the column or attribute in the definition of the object                     |

## DBA\_DB\_PRIVS

DBA\_DB\_PRIVS describes all database grants in the database.

**Table 9-66** Column information

| Column name | Data type    | Description                                                                         |
|-------------|--------------|-------------------------------------------------------------------------------------|
| GRANTOR     | VARCHAR(128) | Name of the user who performed the grant                                            |
| GRANTEE     | VARCHAR(128) | Name of the user or role to whom access was granted                                 |
| PRIVILEGE   | VARCHAR(32)  | Privilege on the database                                                           |
| GRANTABLE   | VARCHAR(3)   | Indicates whether the privilege was granted with the GRANT OPTION (YES) or not (NO) |

## DBA\_DEPENDENCIES

DBA\_DEPENDENCIES describes all dependencies between objects in the database

**Table 9-67** Column information

| Column name            | Data type    | Description                                                                                               |
|------------------------|--------------|-----------------------------------------------------------------------------------------------------------|
| OWNER                  | VARCHAR(128) | Owner of object                                                                                           |
| SCHEMA_NAME            | VARCHAR(128) | Schema Name of object                                                                                     |
| NAME                   | VARCHAR(128) | Name of object                                                                                            |
| TYPE                   | VARCHAR(32)  | Type of object: FUNCTION, PROCEDURE, VIEW, PACKAGE, PACKAGE BODY, TRIGGER                                 |
| REFERENCED_OWNER       | VARCHAR(128) | Owner of the referenced object                                                                            |
| REFERENCED_SCHEMA_NAME | VARCHAR(128) | Schema Name of the referenced object                                                                      |
| REFERENCED_TYPE        | VARCHAR(32)  | Type of the referenced object: FUNCTION, PROCEDURE, TABLE, VIEW, SEQUENCE, PACKAGE, PACKAGE BODY, TRIGGER |
| REFERENCED_LINK_NAME   | VARCHAR(128) | Name of the link to the parent object                                                                     |
| REFERENCED_NAME        | VARCHAR(128) | Name of the referenced object                                                                             |
| DEPENDENCY_TYPE        | VARCHAR(32)  | Indicates whether the dependency is a REF dependency (REF) or not (HARD)                                  |



## DBA\_EXTENTS

DBA\_EXTENTS describes the extents comprising the segments in all tablespaces in the database.

**Table 9-68** Column information

| Column name     | Data type    | Description                                                                                                                |
|-----------------|--------------|----------------------------------------------------------------------------------------------------------------------------|
| OWNER           | VARCHAR(128) | Owner of the segment associated with the extent                                                                            |
| SEGMENT_SCHEMA  | VARCHAR(128) | Schema of the segment associated with the extent                                                                           |
| SEGMENT_NAME    | VARCHAR(128) | Name of the segment associated with the extent                                                                             |
| PARTITION_NAME  | VARCHAR(128) | <ul style="list-style-type: none"> <li>reserved</li> </ul> Object Partition Name (Set to NULL for non-partitioned objects) |
| SEGMENT_TYPE    | VARCHAR(32)  | Type of the segment: TABLE, INDEX                                                                                          |
| TABLESPACE_NAME | VARCHAR(128) | Name of the tablespace containing the extent                                                                               |
| EXTENT_ID       | NUMBER       | <ul style="list-style-type: none"> <li>reserved</li> </ul> Extent number in the segment                                    |
| FILE_ID         | NUMBER       | <ul style="list-style-type: none"> <li>reserved</li> </ul> File identifier number of the file containing the extent        |
| BLOCK_ID        | NUMBER       | <ul style="list-style-type: none"> <li>reserved</li> </ul> Starting block number of the extent                             |
| BYTES           | NUMBER       | Size of the extent in bytes                                                                                                |
| BLOCKS          | NUMBER       | Size of the extent in Oracle blocks                                                                                        |
| RELATIVE_FNO    | NUMBER       | <ul style="list-style-type: none"> <li>reserved</li> </ul> Relative file number of the first extent block                  |

## DBA\_GLOBAL\_SECONDARY\_INDEXES

DBA\_GLOBAL\_SECONDARY\_INDEXES describes all global secondary indexes in the database.



It is available only on a cluster.

**Table 9-69** Column information

| Column name     | Data type    | Description                                                                                               |
|-----------------|--------------|-----------------------------------------------------------------------------------------------------------|
| TABLE_OWNER     | VARCHAR(128) | Owner of the global secondary indexed object                                                              |
| TABLE_SCHEMA    | VARCHAR(128) | Schema of the global secondary indexed object                                                             |
| TABLE_NAME      | VARCHAR(128) | Name of the global secondary indexed object                                                               |
| TABLESPACE_NAME | VARCHAR(128) | Name of the tablespace containing the global secondary index                                              |
| INI_TRANS       | NUMBER       | Initial number of transactions                                                                            |
| MAX_TRANS       | NUMBER       | Maximum number of transactions                                                                            |
| INITIAL_EXTENT  | NUMBER       | Size of the initial extent                                                                                |
| NEXT_EXTENT     | NUMBER       | Size of secondary extents                                                                                 |
| MIN_EXTENTS     | NUMBER       | Minimum number of extents allowed in the segment                                                          |
| MAX_EXTENTS     | NUMBER       | Maximum number of extents allowed in the segment                                                          |
| PCT_FREE        | NUMBER       | Minimum percentage of free space in a block                                                               |
| LOGGING         | VARCHAR(3)   | Indicates whether or not changes to the global secondary index are logged: (YES) or (NO)                  |
| BLOCKS          | NUMBER       | Number of used blocks in the global secondary index                                                       |
| EMPTY_BLOCKS    | NUMBER       | Number of empty blocks in the global secondary index                                                      |
| DROPPED         | VARCHAR(3)   | Indicates whether the global secondary index has been dropped and is in the recycle bin (YES) or not (NO) |

## DBA\_GSI\_PLACE

DBA\_GSI\_PLACE describes node placement of all global secondary indexes in the cluster system.



It is available only on a cluster.

**Table 9-70** Column information

| Column name    | Data type    | Description                                                                                               |
|----------------|--------------|-----------------------------------------------------------------------------------------------------------|
| TABLE_OWNER    | VARCHAR(128) | Owner of the global secondary indexed object                                                              |
| TABLE_SCHEMA   | VARCHAR(128) | Schema of the global secondary indexed object                                                             |
| TABLE_NAME     | VARCHAR(128) | Name of the global secondary indexed object                                                               |
| GROUP_ID       | NUMBER       | Group identifier of the node where the global secondary index placed                                      |
| GROUP_NAME     | VARCHAR(128) | Group name of the node where the global secondary index placed                                            |
| MEMBER_ID      | NUMBER       | Member identifier of the node where the global secondary index placed                                     |
| MEMBER_NAME    | VARCHAR(128) | Member name of the node where the global secondary index placed                                           |
| MEMBER_OFFLINE | BOOLEAN      | data of the cluster member is offline or not                                                              |
| DROPPED        | VARCHAR(3)   | Indicates whether the global secondary index has been dropped and is in the recycle bin (YES) or not (NO) |
| BLOCKS         | NUMBER       | Number of used blocks of the node where the global secondary index placed                                 |

## DBA\_INDEXES

DBA\_INDEXES describes all indexes in the database.

**Table 9-71** Column information

| Column name     | Data type    | Description                                                                                                                                                      |
|-----------------|--------------|------------------------------------------------------------------------------------------------------------------------------------------------------------------|
| OWNER           | VARCHAR(128) | Owner of the index                                                                                                                                               |
| INDEX_SCHEMA    | VARCHAR(128) | Schema of the index                                                                                                                                              |
| INDEX_NAME      | VARCHAR(128) | Name of the index                                                                                                                                                |
| INDEX_TYPE      | VARCHAR(32)  | Type of the index: the value in ( NORMAL, NORMAL/REV, BITMAP, FUNCTION-BASED NORMAL, FUNCTION-BASED NORMAL/REV, FUNCTION-BASED BITMAP, IOT - TOP, DOMAIN )       |
| TABLE_OWNER     | VARCHAR(128) | Owner of the indexed object                                                                                                                                      |
| TABLE_SCHEMA    | VARCHAR(128) | Schema of the indexed object                                                                                                                                     |
| TABLE_NAME      | VARCHAR(128) | Name of the indexed object                                                                                                                                       |
| TABLE_TYPE      | VARCHAR(32)  | Type of the indexed object: the value in ( NEXT OBJECT, INDEX, TABLE, VIEW, SYNONYM, SEQUENCE )                                                                  |
| UNIQUENESS      | VARCHAR(32)  | Indicates whether the index is unique (UNIQUE) or nonunique (NON UNIQUE)                                                                                         |
| COMPRESSION     | VARCHAR(32)  | <ul style="list-style-type: none"> <li>reserved</li> </ul> Indicates whether index compression is enabled (ENABLED) or not (DISABLED)                            |
| PREFIX_LENGTH   | NUMBER       | <ul style="list-style-type: none"> <li>reserved</li> </ul> Number of columns in the prefix of the compression key                                                |
| TABLESPACE_NAME | VARCHAR(128) | Name of the tablespace containing the index                                                                                                                      |
| INI_TRANS       | NUMBER       | Initial number of transactions                                                                                                                                   |
| MAX_TRANS       | NUMBER       | Maximum number of transactions                                                                                                                                   |
| INITIAL_EXTENT  | NUMBER       | Size of the initial extent                                                                                                                                       |
| NEXT_EXTENT     | NUMBER       | Size of secondary extents                                                                                                                                        |
| MIN_EXTENTS     | NUMBER       | Minimum number of extents allowed in the segment                                                                                                                 |
| MAX_EXTENTS     | NUMBER       | Maximum number of extents allowed in the segment                                                                                                                 |
| PCT_INCREASE    | NUMBER       | <ul style="list-style-type: none"> <li>reserved</li> </ul> Percentage increase in extent size                                                                    |
| PCT_THRESHOLD   | NUMBER       | <ul style="list-style-type: none"> <li>reserved</li> </ul> Threshold percentage of block space allowed per index entry                                           |
| INCLUDE_COLUMN  | NUMBER       | <ul style="list-style-type: none"> <li>reserved</li> </ul> Column ID of the last column to be included in index-organized table primary key (non-overflow) index |
| FREELISTS       | NUMBER       | <ul style="list-style-type: none"> <li>reserved</li> </ul> Number of process freelists allocated to this segment                                                 |
| FREELIST_GROUPS | NUMBER       | <ul style="list-style-type: none"> <li>reserved</li> </ul> Number of freelist groups allocated to this segment                                                   |

| Column name             | Data type                       | Description                                                                                                                                                                               |
|-------------------------|---------------------------------|-------------------------------------------------------------------------------------------------------------------------------------------------------------------------------------------|
| PCT_FREE                | NUMBER                          | Minimum percentage of free space in a block                                                                                                                                               |
| LOGGING                 | VARCHAR(3)                      | Indicates whether or not changes to the index are logged: (YES) or (NO)                                                                                                                   |
| BLOCKS                  | NUMBER                          | Number of used blocks in the index                                                                                                                                                        |
| EMPTY_BLOCKS            | NUMBER                          | Number of empty blocks in the index                                                                                                                                                       |
| BLEVEL                  | NUMBER                          | <ul style="list-style-type: none"> <li>reserved</li> </ul> B-Tree level (depth of the index from its root block to its leaf blocks )                                                      |
| LEAF_BLOCKS             | NUMBER                          | <ul style="list-style-type: none"> <li>reserved</li> </ul> Number of leaf blocks in the index                                                                                             |
| DISTINCT_KEYS           | NUMBER                          | Number of distinct indexed values.                                                                                                                                                        |
| AVG_LEAF_BLOCKS_PER_KEY | NUMBER                          | <ul style="list-style-type: none"> <li>reserved</li> </ul> Average number of leaf blocks in which each distinct value in the index appears, rounded to the nearest integer                |
| AVG_DATA_BLOCKS_PER_KEY | NUMBER                          | <ul style="list-style-type: none"> <li>reserved</li> </ul> Average number of data blocks in the table that are pointed to by a distinct value in the index rounded to the nearest integer |
| CLUSTERING_FACTOR       | NUMBER                          | <ul style="list-style-type: none"> <li>reserved</li> </ul> Indicates the amount of order of the rows in the table based on the values of the index                                        |
| STATUS                  | VARCHAR(32)                     | <ul style="list-style-type: none"> <li>reserved</li> </ul> Indicates whether a nonpartitioned index is VALID or UNUSABLE                                                                  |
| NUM_ROWS                | NUMBER                          | <ul style="list-style-type: none"> <li>reserved</li> </ul> Number of rows in the index                                                                                                    |
| SAMPLE_SIZE             | NUMBER                          | Size of the sample used to analyze the index                                                                                                                                              |
| LAST_ANALYZED           | TIMESTAMP(6) WITH OUT TIME ZONE | Date on which this index was most recently analyzed                                                                                                                                       |
| DEGREE                  | VARCHAR(32)                     | <ul style="list-style-type: none"> <li>reserved</li> </ul> Number of threads per instance for scanning the index, or DEFAULT                                                              |
| INSTANCES               | VARCHAR(32)                     | <ul style="list-style-type: none"> <li>reserved</li> </ul> Number of instances across which the indexes to be scanned, or DEFAULT                                                         |
| PARTITIONED             | VARCHAR(3)                      | <ul style="list-style-type: none"> <li>reserved</li> </ul> Indicates whether the index is partitioned (YES) or not (NO)                                                                   |
| TEMPORARY               | VARCHAR(1)                      | Indicates whether the index is on a temporary table (Y) or not (N)                                                                                                                        |
| GENERATED               | VARCHAR(1)                      | Indicates whether the name of the index is system-generated (Y) or not (N)                                                                                                                |
| SECONDARY               | VARCHAR(1)                      | <ul style="list-style-type: none"> <li>reserved</li> </ul> Indicates whether the index is a secondary object created by the method of the Data Cartridge (Y) or not (N)                   |

| Column name             | Data type     | Description                                                                                                                                                                                                                                                     |
|-------------------------|---------------|-----------------------------------------------------------------------------------------------------------------------------------------------------------------------------------------------------------------------------------------------------------------|
| BUFFER_POOL             | VARCHAR(32)   | <ul style="list-style-type: none"> <li>reserved</li> </ul> Buffer pool to be used for index blocks                                                                                                                                                              |
| FLASH_CACHE             | VARCHAR(32)   | <ul style="list-style-type: none"> <li>reserved</li> </ul> Database Smart Flash Cache hint to be used for index blocks                                                                                                                                          |
| CELL_FLASH_CACHE        | VARCHAR(32)   | <ul style="list-style-type: none"> <li>reserved</li> </ul> Cell flash cache hint to be used for index blocks                                                                                                                                                    |
| USER_STATS              | VARCHAR(3)    | <ul style="list-style-type: none"> <li>reserved</li> </ul> Indicates whether statistics were entered directly by the user (YES) or not (NO)                                                                                                                     |
| DURATION                | VARCHAR(32)   | Indicates the duration of a temporary table, the value is in ( TRANSACTION, SESSION )                                                                                                                                                                           |
| PCT_DIRECT_ACCESS       | NUMBER        | <ul style="list-style-type: none"> <li>reserved</li> </ul> For a secondary index on an index-organized table, the percentage of rows with VALID guess                                                                                                           |
| ITYP_OWNER              | VARCHAR(128)  | <ul style="list-style-type: none"> <li>reserved</li> </ul> For a domain index, the owner of the indextype                                                                                                                                                       |
| ITYP_NAME               | VARCHAR(128)  | <ul style="list-style-type: none"> <li>reserved</li> </ul> For a domain index, the name of the indextype                                                                                                                                                        |
| PARAMETERS              | VARCHAR(1024) | <ul style="list-style-type: none"> <li>reserved</li> </ul> For a domain index, the parameter string                                                                                                                                                             |
| GLOBAL_STATS            | VARCHAR(3)    | <ul style="list-style-type: none"> <li>reserved</li> </ul> For partitioned indexes, indicates whether statistics were collected by analyzing the index as a whole (YES) or were estimated from statistics on underlying index partitions and subpartitions (NO) |
| DOMIDX_STATUS           | VARCHAR(32)   | <ul style="list-style-type: none"> <li>reserved</li> </ul> Status of a domain index                                                                                                                                                                             |
| DOMIDX_OPSTATUS         | VARCHAR(32)   | <ul style="list-style-type: none"> <li>reserved</li> </ul> Status of the operation on a domain index                                                                                                                                                            |
| FUNCIDX_STATUS          | VARCHAR(32)   | <ul style="list-style-type: none"> <li>reserved</li> </ul> Status of a function-based index                                                                                                                                                                     |
| JOIN_INDEX              | VARCHAR(3)    | <ul style="list-style-type: none"> <li>reserved</li> </ul> Indicates whether the index is a join index (YES) or not (NO)                                                                                                                                        |
| IOT_REDUNDANT_PKEY_ELIM | VARCHAR(3)    | <ul style="list-style-type: none"> <li>reserved</li> </ul> Indicates whether redundant primary key columns are eliminated from secondary indexes on index-organized tables (YES) or not (NO)                                                                    |
| DROPPED                 | VARCHAR(3)    | Indicates whether the index has been dropped and is in the recycle bin (YES) or not (NO)                                                                                                                                                                        |
| VISIBILITY              | VARCHAR(3)    | <ul style="list-style-type: none"> <li>reserved</li> </ul> Indicates whether the index is VISIBLE or INVISIBLE to the optimizer                                                                                                                                 |
| DOMIDX_MANAGE           |               | <ul style="list-style-type: none"> <li>reserved</li> </ul> If this is a domain index, indicates whether the domain index is syst                                                                                                                                |

| Column name     | Data type     | Description                                                            |
|-----------------|---------------|------------------------------------------------------------------------|
| MENT            | VARCHAR(32)   | em-managed (SYSTEM_MANAGED) or user-managed (USER_MANAGED)             |
| SEGMENT_CREATED | VARCHAR(3)    | Indicates whether the index segment has been created (YES) or not (NO) |
| COMMENTS        | VARCHAR(1024) | Comments of the index                                                  |
| EMPTY_BLOCKS    | NUMBER        | Number of empty blocks in the index                                    |

## DBA\_IND\_COLUMNS

DBA\_IND\_COLUMNS describes the columns of all the indexes on all tables and clusters in the database.

**Table 9-72** Column information

| Column name     | Data type    | Description                                                                                                                  |
|-----------------|--------------|------------------------------------------------------------------------------------------------------------------------------|
| INDEX_OWNER     | VARCHAR(128) | Owner of the index                                                                                                           |
| INDEX_SCHEMA    | VARCHAR(128) | Schema of the index                                                                                                          |
| INDEX_NAME      | VARCHAR(128) | Name of the index                                                                                                            |
| TABLE_OWNER     | VARCHAR(128) | Owner of the table or cluster                                                                                                |
| TABLE_SCHEMA    | VARCHAR(128) | Schema of the table or cluster                                                                                               |
| TABLE_NAME      | VARCHAR(128) | Name of the table or cluster                                                                                                 |
| COLUMN_NAME     | VARCHAR(128) | Column name or attribute of the object type column                                                                           |
| COLUMN_POSITION | NUMBER       | Position of the column or attribute within the index                                                                         |
| COLUMN_LENGTH   | NUMBER       | Indexed length of the column                                                                                                 |
| CHAR_LENGTH     | NUMBER       | <ul style="list-style-type: none"> <li>reserved</li> </ul> Maximum codepoint length of the column                            |
| DESCEND         | VARCHAR(32)  | Indicates whether the column is sorted in descending order (DESC) or ascending order (ASC)                                   |
| NULL_ORDER      | VARCHAR(32)  | Indicates whether the null value of the column is sorted in nulls first order (NULLS FIRST) or nulls last order (NULLS LAST) |



## DBA\_IND\_PLACE

DBA\_IND\_PLACE describes node placement of all indexes in the cluster system.



It is available only on a cluster.

**Table 9-73** Column information

| Column name    | Data type                          | Description                                                                              |
|----------------|------------------------------------|------------------------------------------------------------------------------------------|
| OWNER          | VARCHAR(128)                       | Owner of the index                                                                       |
| INDEX_SCHEMA   | VARCHAR(128)                       | Schema of the index                                                                      |
| INDEX_NAME     | VARCHAR(128)                       | Name of the index                                                                        |
| TABLE_OWNER    | VARCHAR(128)                       | Owner of the indexed object                                                              |
| TABLE_SCHEMA   | VARCHAR(128)                       | Schema of the indexed object                                                             |
| TABLE_NAME     | VARCHAR(128)                       | Name of the indexed object                                                               |
| GROUP_ID       | NUMBER                             | Group identifier of the node where the index placed                                      |
| GROUP_NAME     | VARCHAR(128)                       | Group name of the node where the index placed                                            |
| MEMBER_ID      | NUMBER                             | Member identifier of the node where the index placed                                     |
| MEMBER_NAME    | VARCHAR(128)                       | Member name of the node where the index placed                                           |
| MEMBER_OFFLINE | BOOLEAN                            | data of the cluster member is offline or not                                             |
| DROPPED        | VARCHAR(3)                         | Indicates whether the index has been dropped and is in the recycle bin (YES) or not (NO) |
| DISTINCT_KEYS  | NUMBER                             | (deprecated)                                                                             |
| SAMPLE_SIZE    | NUMBER                             | (deprecated)                                                                             |
| BLOCKS         | NUMBER                             | Number of used blocks of the node where the index placed                                 |
| LAST_ANALYZED  | TIMESTAMP(2) WITH<br>OUT TIME ZONE | (deprecated)                                                                             |

## DBA\_NONSCHEMA\_COMMENTS

DBA\_NONSCHEMA\_COMMENTS displays comments on all non-schema objects (database, authorizations, schemas, tablespaces).

**Table 9-74** Column information

| Column name | Data type     | Description                                                                         |
|-------------|---------------|-------------------------------------------------------------------------------------|
| OBJECT_NAME | VARCHAR(128)  | Name of the non-schema object                                                       |
| OBJECT_TYPE | VARCHAR(32)   | Type of the non-schema object: DATABASE, PROFILE, AUTHORIZATION, SCHEMA, TABLESPACE |
| COMMENTS    | VARCHAR(1024) | Comments of the non-schema object                                                   |

## DBA\_OBJECTS

DBA\_OBJECTS describes all objects in the database.

**Table 9-75** Column information

| Column name    | Data type                          | Description                                                                                                                           |
|----------------|------------------------------------|---------------------------------------------------------------------------------------------------------------------------------------|
| OWNER          | VARCHAR(128)                       | Owner of the object                                                                                                                   |
| SCHEMA_NAME    | VARCHAR(128)                       | Schema of the object                                                                                                                  |
| OBJECT_NAME    | VARCHAR(128)                       | Name of the object                                                                                                                    |
| SUBOBJECT_NAME | VARCHAR(128)                       | Name of the subobject (for example, partition)                                                                                        |
| OBJECT_ID      | NUMBER                             | Dictionary object number of the object                                                                                                |
| DATA_OBJECT_ID | NUMBER                             | Dictionary object number of the segment that contains the object                                                                      |
| OBJECT_TYPE    | VARCHAR(32)                        | Type of the object (such as TABLE, INDEX)                                                                                             |
| CREATED        | TIMESTAMP(2) WITH<br>OUT TIME ZONE | Timestamp for the creation of the object                                                                                              |
| LAST_DDL_TIME  | TIMESTAMP(2) WITH<br>OUT TIME ZONE | Timestamp for the last modification of the object resulting from a DDL statement                                                      |
| TIMESTAMP      | VARCHAR(32)                        | Timestamp for the specification of the object (character data)                                                                        |
| STATUS         | VARCHAR(32)                        | Status of the object: the value in ( VALID, INVALID, N/A )                                                                            |
| TEMPORARY      | VARCHAR(1)                         | Indicates whether the object is temporary (the current session can see only data that it placed in this object itself) (Y) or not (N) |
| GENERATED      | VARCHAR(1)                         | Indicates whether the name of this object was system-generated (Y) or not (N)                                                         |
| SECONDARY      | VARCHAR(1)                         | Indicates whether this is a secondary object created by the ODCIIndexCreate method of the Oracle Data Cartridge (Y) or not (N)        |
| NAMESPACE      | NUMBER                             | Namespace for the object                                                                                                              |
| EDITION_NAME   | VARCHAR(128)                       | <ul style="list-style-type: none"> <li>reserved</li> </ul> Name of the edition in which the object is actual                          |
| DROPPED        | VARCHAR(3)                         | Indicates whether the object has been dropped and is in the recycle bin (YES) or not (NO)                                             |

## DBA\_PACKAGE\_PRIVS

DBA\_PACKAGE\_PRIVS describes all packages grants in the database.

**Table 9-76** Column information

| Column name      | Data type    | Description                                                                         |
|------------------|--------------|-------------------------------------------------------------------------------------|
| GRANTOR          | VARCHAR(128) | Name of the user who performed the grant                                            |
| GRANTEE          | VARCHAR(128) | Name of the user or role to whom access was granted                                 |
| PROCEDURE_OWNER  | VARCHAR(128) | Owner of the procedure, function or package                                         |
| PROCEDURE_SCHEMA | VARCHAR(128) | Schema of the procedure, function or package                                        |
| PROCEDURE_NAME   | VARCHAR(128) | Name of the procedure, function or package                                          |
| PRIVILEGE        | VARCHAR(32)  | Privilege on the procedure, function or package                                     |
| GRANTABLE        | VARCHAR(3)   | Indicates whether the privilege was granted with the GRANT OPTION (YES) or not (NO) |

## DBA\_PROCEDURES

DBA\_PROCEDURES lists all function, procedures or pacakage

**Table 9-77** Column information

| Column name    | Data type    | Description                                                                                             |
|----------------|--------------|---------------------------------------------------------------------------------------------------------|
| OWNER          | VARCHAR(128) | Owner of function, procedures or pacakage                                                               |
| SCHEMA_NAME    | VARCHAR(128) | Schema Name of function, procedures or package                                                          |
| OBJECT_NAME    | VARCHAR(128) | Name of function, procedures or pacakage                                                                |
| PROCEDURE_NAME | VARCHAR(128) | Name when a procedures in pacakage                                                                      |
| OBJECT_ID      | NUMBER       | ID of a function, procedures or pacakage                                                                |
| SUBPROGRAM_ID  | NUMBER       | ID of procedures in pacakage                                                                            |
| OVERLOAD       | VARCHAR(32)  | ID of overloading procedure in pacakage                                                                 |
| OBJECT_TYPE    | VARCHAR(32)  | Type of function, procedures or package                                                                 |
| AGGREGATE      | VARCHAR(3)   | Indicate whether the procedure is an aggreage function(YES) or not (NO)                                 |
| PIPELINED      | VARCHAR(3)   | Indicate whether the procedure is a pipelined table function(YES) or not(NO)                            |
| IMPLTYPEOWNER  | VARCHAR(128) | Name of the owner of the implementation type, if any                                                    |
| IMPLTYPENAME   | VARCHAR(128) | Name of the implementation type, if any                                                                 |
| PARALLEL       | VARCHAR(3)   | Indicates whether the procedure or function is parallel-enabled (YES ) or not (NO)                      |
| INTERFACE      | VARCHAR(3)   | YES, if the procedure/function is a table function implemented using the SQLCLI interface; otherwise NO |
| DETERMINISTIC  | VARCHAR(3)   | YES, if the procedure/function is declared to be deterministic; otherwise NO                            |
| AUTHID         | VARCHAR(32)  | Indicates whether the procedure/function is declared to execute as DEFINER or CURRENT_USER (invoker)    |

## DBA\_PROC\_PRIVS

DBA\_PROC\_PRIVS describes the procedure grants, for which the current user is the procedure owner, grantor, or grantee, or for which an enabled role or PUBLIC is the grantee.

**Table 9-78** Column information

| Column name      | Data type    | Description                                                                         |
|------------------|--------------|-------------------------------------------------------------------------------------|
| GRANTOR          | VARCHAR(128) | Name of the user who performed the grant                                            |
| GRANTEE          | VARCHAR(128) | Name of the user or role to whom access was granted                                 |
| PROCEDURE_OWNER  | VARCHAR(128) | Owner of the procedure, function or package                                         |
| PROCEDURE_SCHEMA | VARCHAR(128) | Schema of the procedure, function or package                                        |
| PROCEDURE_NAME   | VARCHAR(128) | Name of the procedure, function or package                                          |
| PRIVILEGE        | VARCHAR(32)  | Privilege on the procedure, function or package                                     |
| GRANTABLE        | VARCHAR(3)   | Indicates whether the privilege was granted with the GRANT OPTION (YES) or not (NO) |

## DBA\_PROFILES

DBA\_PROFILES displays all profiles and their limits.

**Table 9-79** Column information

| Column name   | Data type    | Description                                                                |
|---------------|--------------|----------------------------------------------------------------------------|
| PROFILE_NAME  | VARCHAR(128) | Profile name                                                               |
| RESOURCE_NAME | VARCHAR(128) | Resource name                                                              |
| RESOURCE_TYPE | VARCHAR(32)  | Indicates whether the resource profile is a KERNEL or a PASSWORD parameter |
| LIMIT_VALUE   | LONG VARCHAR | Limit placed on this resource for this profile                             |
| COMMON        | VARCHAR(3)   | Indicates whether a given profile is common. (YES or NO)                   |

## DBA\_RECYCLEBIN

DBA\_RECYCLEBIN describes all recycle bins in the database.

**Table 9-80** Column information

| Column name     | Data type                          | Description                                                                             |
|-----------------|------------------------------------|-----------------------------------------------------------------------------------------|
| OWNER           | VARCHAR(128)                       | Owner of the object                                                                     |
| SCHEMA_NAME     | VARCHAR(128)                       | Schema name of the object                                                               |
| OBJECT_NAME     | VARCHAR(128)                       | Name of the object                                                                      |
| ORIGINAL_NAME   | VARCHAR(128)                       | Original name of the object                                                             |
| OPERATION       | VARCHAR(4)                         | Operation carried out on the object                                                     |
| OBJECT_TYPE     | VARCHAR(32)                        | Type of the object                                                                      |
| TABLESPACE_NAME | VARCHAR(128)                       | Name of the tablespace containing the object                                            |
| CREATED_TIME    | TIMESTAMP(2) WITH<br>OUT TIME ZONE | Created time of the object                                                              |
| DROPPED_TIME    | TIMESTAMP(2) WITH<br>OUT TIME ZONE | Dropped time of the object                                                              |
| DROP_SCN        | VARCHAR(128)                       | System change number (SCN) of the transaction which moved the object to the recycle bin |
| DROP_GCN        | NUMBER                             | Global change number (GCN) of the transaction which moved the object to the recycle bin |
| DROP_DCN        | NUMBER                             | Domain change number (DCN) of the transaction which moved the object to the recycle bin |
| DROP_LCN        | NUMBER                             | Local change number (LCN) of the transaction which moved the object to the recycle bin  |
| CAN_UNDROP      | VARCHAR(3)                         | Indicates whether the object can be undropped (YES) or not (NO)                         |
| CAN_PURGE       | VARCHAR(3)                         | Indicates whether the object can be purged (YES) or not (NO)                            |
| BASE_OBJECT     | NUMBER                             | Object number of the base object                                                        |
| PURGE_OBJECT    | NUMBER                             | Object number for the object which gets purged                                          |



## DBA\_SCHEMAS

Identify the schemata in the database.

**Table 9-81** Column information

| Column name   | Data type                      | Description                      |
|---------------|--------------------------------|----------------------------------|
| SCHEMA_OWNER  | VARCHAR(128)                   | Owner of the schema              |
| SCHEMA_NAME   | VARCHAR(128)                   | Name of the schema               |
| CREATED_TIME  | TIMESTAMP(2) WITHOUT TIME ZONE | Created time of the schema       |
| MODIFIED_TIME | TIMESTAMP(2) WITHOUT TIME ZONE | Last modified time of the schema |
| COMMENTS      | VARCHAR(1024)                  | Comments of the schema           |

## DBA\_SCHEMA\_PATH

DBA\_SCHEMA\_PATH describes the schema search order of all authorizations in the database.

**Table 9-82** Column information

| Column name  | Data type    | Description                              |
|--------------|--------------|------------------------------------------|
| AUTH_NAME    | VARCHAR(128) | Name of the authorization                |
| SCHEMA_NAME  | VARCHAR(128) | Name of the schema                       |
| SEARCH_ORDER | NUMBER       | Schema search order of the authorization |

## DBA\_SCHEMA\_PRIVS

DBA\_SCHEMA\_PRIVS describes all schema grants in the database.

**Table 9-83** Column information

| Column name | Data type    | Description                                                                         |
|-------------|--------------|-------------------------------------------------------------------------------------|
| GRANTOR     | VARCHAR(128) | Name of the user who performed the grant                                            |
| GRANTEE     | VARCHAR(128) | Name of the user or role to whom access was granted                                 |
| OWNER       | VARCHAR(128) | Owner of the schema                                                                 |
| SCHEMA_NAME | VARCHAR(128) | Name of the schema                                                                  |
| PRIVILEGE   | VARCHAR(32)  | Privilege on the schema                                                             |
| GRANTABLE   | VARCHAR(3)   | Indicates whether the privilege was granted with the GRANT OPTION (YES) or not (NO) |

## DBA\_SEQUENCES

DBA\_SEQUENCES describes all sequences in the database.

**Table 9-84** Column information

| Column name     | Data type     | Description                                                                                                                                           |
|-----------------|---------------|-------------------------------------------------------------------------------------------------------------------------------------------------------|
| SEQUENCE_OWNER  | VARCHAR(128)  | Owner of the sequence                                                                                                                                 |
| SEQUENCE_SCHEMA | VARCHAR(128)  | Schema of the sequence                                                                                                                                |
| SEQUENCE_NAME   | VARCHAR(128)  | Sequence name                                                                                                                                         |
| MIN_VALUE       | NUMBER        | Minimum value of the sequence                                                                                                                         |
| MAX_VALUE       | NUMBER        | Maximum value of the sequence                                                                                                                         |
| INCREMENT_BY    | NUMBER        | Value by which sequence is incremented                                                                                                                |
| CYCLE_FLAG      | VARCHAR(1)    | Indicates whether the sequence wraps around on reaching the limit (Y) or not (N)                                                                      |
| ORDER_FLAG      | VARCHAR(1)    | <ul style="list-style-type: none"> <li>reserved</li> </ul> Indicates whether sequence numbers are generated in order (Y) or not (N)                   |
| CACHE_SIZE      | NUMBER        | Number of sequence numbers to cache                                                                                                                   |
| LAST_NUMBER     | NUMBER        | Last sequence number written to database. If a sequence uses caching, the number written to database is the last number placed in the sequence cache. |
| COMMENTS        | VARCHAR(1024) | Comments of the sequence                                                                                                                              |

## DBA\_SEQ\_PRIVS

DBA\_SEQ\_PRIVS describes all sequence grants in the database.

**Table 9-85** Column information

| Column name     | Data type    | Description                                                                         |
|-----------------|--------------|-------------------------------------------------------------------------------------|
| GRANTOR         | VARCHAR(128) | Name of the user who performed the grant                                            |
| GRANTEE         | VARCHAR(128) | Name of the user or role to whom access was granted                                 |
| SEQUENCE_OWNER  | VARCHAR(128) | Owner of the sequence                                                               |
| SEQUENCE_SCHEMA | VARCHAR(128) | Schema of the sequence                                                              |
| SEQUENCE_NAME   | VARCHAR(128) | Name of the sequence                                                                |
| PRIVILEGE       | VARCHAR(32)  | Privilege on the sequence                                                           |
| GRANTABLE       | VARCHAR(3)   | Indicates whether the privilege was granted with the GRANT OPTION (YES) or not (NO) |

## DBA\_SHARD\_KEY\_COLUMNS

DBA\_SHARD\_KEY\_COLUMNS describes shard key columns of all shared tables in the cluster system.



It is available only on a cluster.

**Table 9-86** Column information

| Column name     | Data type    | Description                                 |
|-----------------|--------------|---------------------------------------------|
| OWNER           | VARCHAR(128) | Owner of the table                          |
| TABLE_SCHEMA    | VARCHAR(128) | Schema of the table                         |
| TABLE_NAME      | VARCHAR(128) | Name of the table                           |
| COLUMN_NAME     | VARCHAR(128) | Column name of the shard key                |
| COLUMN_POSITION | NUMBER       | Position of the column within the shard key |

## DBA\_SOURCE

DBA\_SOURCE describes the text source of the stored objects accessible to the current user.

**Table 9-87** Column information

| Column name   | Data type    | Description                                                         |
|---------------|--------------|---------------------------------------------------------------------|
| OWNER         | VARCHAR(128) | Owner of object                                                     |
| SCHEMA_NAME   | VARCHAR(128) | Schema Name of object                                               |
| NAME          | VARCHAR(128) | Name of object                                                      |
| TYPE          | VARCHAR(32)  | Type of object: FUNCTION, PROCEDURE, PACKAGE, PACKAGE BODY, TRIGGER |
| LINE          | NUMBER       | Line number of this line of source                                  |
| TEXT          | LONG VARCHAR | Text source of the stored object                                    |
| ORIGIN_CON_ID | VARCHAR(256) | ID of the container where the data originates                       |

## DBA\_STAT\_SYSTEM

DBA\_STAT\_SYSTEM describes analyzed system statistics.

**Table 9-88** Column information

| Column name     | Data type                          | Description                                        |
|-----------------|------------------------------------|----------------------------------------------------|
| CPU_OPS         | NATIVE_BIGINT                      | OPS(operations per second) of CPU                  |
| NETWORK_IOPS    | NATIVE_BIGINT                      | IOPS(I/O operations per second) of Cluster NETWORK |
| NETWORK_BUFSIZE | NATIVE_BIGINT                      | buffer size of Cluster NETWORK when analyzed       |
| LAST_ANALYZED   | TIMESTAMP(2) WITH<br>OUT TIME ZONE | Date on which the table was most recently analyzed |



## DBA\_SYS\_PRIVS

DBA\_SYS\_PRIVS describes all system (database, tablespace, schema) privileges in the database.

**Table 9-89** Column information

| Column name  | Data type    | Description                                                                         |
|--------------|--------------|-------------------------------------------------------------------------------------|
| GRANTEE      | VARCHAR(128) | Name of the grantee                                                                 |
| PRIVILEGE    | VARCHAR(256) | System(database, tablespace, schema) privilege                                      |
| GRANTABLE    | VARCHAR(3)   | Indicates whether the privilege was granted with the GRANT OPTION (YES) or not (NO) |
| ADMIN_OPTION | VARCHAR(3)   | equal to GRANTABLE column                                                           |

## DBA\_SYNONYMS

DBA\_SYNONYMS describes all synonyms in the database.

**Table 9-90** Column information

| Column name        | Data type    | Description             |
|--------------------|--------------|-------------------------|
| SYNONYM_OWNER      | VARCHAR(128) | Owner of the synonym    |
| SYNONYM_SCHEMA     | VARCHAR(128) | Schema of the synonym   |
| SYNONYM_NAME       | VARCHAR(128) | Synonym name            |
| OBJECT_SCHEMA_NAME | VARCHAR(128) | Object schema name      |
| OBJECT_NAME        | VARCHAR(128) | Object name             |
| DB_LINK            | VARCHAR(128) | Reserved for future use |

## DBA\_TABLES

DBA\_TABLES describes all relational tables in the database.

**Table 9-91** Column information

| Column name     | Data type    | Description                                                                                                                                                               |
|-----------------|--------------|---------------------------------------------------------------------------------------------------------------------------------------------------------------------------|
| OWNER           | VARCHAR(128) | Owner of the table                                                                                                                                                        |
| TABLE_SCHEMA    | VARCHAR(128) | Schema of the table                                                                                                                                                       |
| TABLE_NAME      | VARCHAR(128) | Name of the table                                                                                                                                                         |
| TABLESPACE_NAME | VARCHAR(128) | Name of the tablespace containing the table                                                                                                                               |
| CLUSTER_NAME    | VARCHAR(128) | <ul style="list-style-type: none"> <li>reserved</li> </ul> Name of the cluster                                                                                            |
| IOT_NAME        | VARCHAR(128) | <ul style="list-style-type: none"> <li>reserved</li> </ul> Name of the index-organized table                                                                              |
| STATUS          | VARCHAR(32)  | <ul style="list-style-type: none"> <li>reserved</li> </ul> If a previous DROP TABLE operation failed, indicates whether the table is unusable (UNUSABLE) or valid (VALID) |
| PCT_FREE        | NUMBER       | Minimum percentage of free space in a block                                                                                                                               |
| PCT_USED        | NUMBER       | Minimum percentage of used space in a block                                                                                                                               |
| INI_TRANS       | NUMBER       | Initial number of transactions                                                                                                                                            |
| MAX_TRANS       | NUMBER       | Maximum number of transactions                                                                                                                                            |
| INITIAL_EXTENT  | NUMBER       | Size of the initial extent (in bytes)                                                                                                                                     |
| NEXT_EXTENT     | NUMBER       | Size of secondary extents (in bytes)                                                                                                                                      |
| MIN_EXTENTS     | NUMBER       | Minimum number of extents allowed in the segment                                                                                                                          |
| MAX_EXTENTS     | NUMBER       | Maximum number of extents allowed in the segment                                                                                                                          |
| PCT_INCREASE    | NUMBER       | <ul style="list-style-type: none"> <li>reserved</li> </ul> Percentage increase in extent size                                                                             |
| FREELISTS       | NUMBER       | <ul style="list-style-type: none"> <li>reserved</li> </ul> Number of process freelists allocated to the segment                                                           |
| FREELIST_GROUPS | NUMBER       | <ul style="list-style-type: none"> <li>reserved</li> </ul> Number of freelist groups allocated to the segment                                                             |
| LOGGING         | VARCHAR(3)   | Indicates whether or not changes to the table are logged                                                                                                                  |
| BACKED_UP       | VARCHAR(1)   | <ul style="list-style-type: none"> <li>reserved</li> </ul> Indicates whether the table has been backed up since the last modification (Y) or not (N)                      |
| NUM_ROWS        | NUMBER       | Number of rows in the table                                                                                                                                               |
| BLOCKS          | NUMBER       | <ul style="list-style-type: none"> <li>reserved</li> </ul> Number of used blocks in the table                                                                             |
| EMPTY_BLOCKS    | NUMBER       | <ul style="list-style-type: none"> <li>reserved</li> </ul> Number of empty (never used) blocks in the table                                                               |
|                 |              | <ul style="list-style-type: none"> <li>reserved</li> </ul>                                                                                                                |

| Column name               | Data type                         | Description                                                                                                                                                                                                             |
|---------------------------|-----------------------------------|-------------------------------------------------------------------------------------------------------------------------------------------------------------------------------------------------------------------------|
| AVG_SPACE                 | NUMBER                            | Average available free space in the table                                                                                                                                                                               |
| CHAIN_CNT                 | NUMBER                            | <ul style="list-style-type: none"> <li>reserved</li> </ul> Number of rows in the table that are chained from one data block to another or that have migrated to a new block, requiring a link to preserve the old rowid |
| AVG_ROW_LEN               | NUMBER                            | <ul style="list-style-type: none"> <li>reserved</li> </ul> Average row length, including row overhead                                                                                                                   |
| AVG_SPACE_FREELIST_BLOCKS | NUMBER                            | <ul style="list-style-type: none"> <li>reserved</li> </ul> Average freespace of all blocks on a freelist                                                                                                                |
| NUM_FREELIST_BLOCKS       | NUMBER                            | <ul style="list-style-type: none"> <li>reserved</li> </ul> Number of blocks on the freelist                                                                                                                             |
| DEGREE                    | VARCHAR(32)                       | <ul style="list-style-type: none"> <li>reserved</li> </ul> Number of threads per instance for scanning the table, or DEFAULT                                                                                            |
| INSTANCES                 | VARCHAR(32)                       | <ul style="list-style-type: none"> <li>reserved</li> </ul> Number of instances across which the table is to be scanned, or DEFAULT                                                                                      |
| CACHE                     | VARCHAR(1)                        | <ul style="list-style-type: none"> <li>reserved</li> </ul> Indicates whether the table is to be cached in the buffer cache (Y) or not (N)                                                                               |
| TABLE_LOCK                | VARCHAR(32)                       | Indicates whether table locking is enabled (ENABLED) or disabled (DISABLED)                                                                                                                                             |
| SAMPLE_SIZE               | NUMBER                            | Sample size used in analyzing the table                                                                                                                                                                                 |
| LAST_ANALYZED             | TIMESTAMP(6)<br>WITHOUT TIME ZONE | Date on which the table was most recently analyzed                                                                                                                                                                      |
| PARTITIONED               | VARCHAR(3)                        | <ul style="list-style-type: none"> <li>reserved</li> </ul> Indicates whether the table is partitioned (YES) or not (NO)                                                                                                 |
| IOT_TYPE                  | VARCHAR(32)                       | <ul style="list-style-type: none"> <li>reserved</li> </ul> If the table is an index-organized table, then IOT_TYPE is IOT, IOT_OVERFLOW, or IOT_MAPPING.                                                                |
| TEMPORARY                 | VARCHAR(1)                        | Indicates whether the table is temporary (Y) or not (N)                                                                                                                                                                 |
| SECONDARY                 | VARCHAR(1)                        | <ul style="list-style-type: none"> <li>reserved</li> </ul> Indicates whether the table is a secondary object created by cartridge                                                                                       |
| NESTED                    | VARCHAR(3)                        | <ul style="list-style-type: none"> <li>reserved</li> </ul> Indicates whether the table is a nested table (YES) or not (NO)                                                                                              |
| BUFFER_POOL               | VARCHAR(32)                       | <ul style="list-style-type: none"> <li>reserved</li> </ul> Buffer pool to be used for table blocks                                                                                                                      |
| FLASH_CACHE               | VARCHAR(32)                       | <ul style="list-style-type: none"> <li>reserved</li> </ul> Database Smart Flash Cache hint to be used for table blocks                                                                                                  |
| CELL_FLASH_CACHE          | VARCHAR(32)                       | <ul style="list-style-type: none"> <li>reserved</li> </ul> Cell flash cache hint to be used for table blocks                                                                                                            |
|                           |                                   | <ul style="list-style-type: none"> <li>reserved</li> </ul>                                                                                                                                                              |

| Column name     | Data type    | Description                                                                                                                                                                              |
|-----------------|--------------|------------------------------------------------------------------------------------------------------------------------------------------------------------------------------------------|
| ROW_MOVEMENT    | VARCHAR(32)  | If a partitioned table, indicates whether row movement is enabled (ENABLED) or disabled (DISABLED)                                                                                       |
| GLOBAL_STATS    | VARCHAR(3)   | <ul style="list-style-type: none"> <li>reserved</li> </ul> For partitioned tables, indicates whether statistics for the table as a whole (global statistics) are accurate (YES)          |
| USER_STATS      | VARCHAR(3)   | <ul style="list-style-type: none"> <li>reserved</li> </ul> Indicates whether statistics were entered directly by the user (YES) or not (NO)                                              |
| DURATION        | VARCHAR(32)  | Indicates the duration of a temporary table, the value is in ( TRANSACTION, SESSION )                                                                                                    |
| SKIP_CORRUPT    | VARCHAR(32)  | <ul style="list-style-type: none"> <li>reserved</li> </ul> Indicates whether Database ignores blocks marked corrupt during table and index scans (ENABLED) or raises an error (DISABLED) |
| MONITORING      | VARCHAR(3)   | <ul style="list-style-type: none"> <li>reserved</li> </ul> Indicates whether the table has the MONITORING attribute set (YES) or not (NO)                                                |
| CLUSTER_OWNER   | VARCHAR(128) | <ul style="list-style-type: none"> <li>reserved</li> </ul> Owner of the cluster, if any                                                                                                  |
| DEPENDENCIES    | VARCHAR(32)  | <ul style="list-style-type: none"> <li>reserved</li> </ul> Indicates whether row-level dependency tracking is enabled (ENABLED) or disabled (DISABLED)                                   |
| COMPRESSION     | VARCHAR(32)  | <ul style="list-style-type: none"> <li>reserved</li> </ul> Indicates whether table compression is enabled (ENABLED) or not (DISABLED)                                                    |
| COMPRESS_FOR    | VARCHAR(32)  | <ul style="list-style-type: none"> <li>reserved</li> </ul> Default compression for what kind of operations                                                                               |
| DROPPED         | VARCHAR(3)   | Indicates whether the table has been dropped and is in the recycle bin (YES) or not (NO)                                                                                                 |
| READ_ONLY       | VARCHAR(3)   | Indicates whether the table IS READ-ONLY (YES) or not (NO)                                                                                                                               |
| SEGMENT_CREATED | VARCHAR(3)   | Indicates whether the table segment has been created (YES) or not (NO)                                                                                                                   |
| RESULT_CACHE    | VARCHAR(32)  | <ul style="list-style-type: none"> <li>reserved</li> </ul> Result cache mode annotation for the table: the value in ( NULL, DEFAULT, FORCE, MANUAL )                                     |

## DBA\_TABLESPACES

DBA\_TABLESPACES describes all tablespaces in the database.

**Table 9-92** Column information

| Column name              | Data type    | Description                                                                                                                                                                           |
|--------------------------|--------------|---------------------------------------------------------------------------------------------------------------------------------------------------------------------------------------|
| TABLESPACE_NAME          | VARCHAR(128) | Name of the tablespace                                                                                                                                                                |
| BLOCK_SIZE               | NUMBER       | Tablespace block size                                                                                                                                                                 |
| INITIAL_EXTENT           | NUMBER       | <ul style="list-style-type: none"> <li>reserved</li> </ul> Default initial extent size (in bytes)                                                                                     |
| NEXT_EXTENT              | NUMBER       | <ul style="list-style-type: none"> <li>reserved</li> </ul> Default incremental extent size (in bytes)                                                                                 |
| MIN_EXTENTS              | NUMBER       | <ul style="list-style-type: none"> <li>reserved</li> </ul> Default minimum number of extents                                                                                          |
| MAX_EXTENTS              | NUMBER       | <ul style="list-style-type: none"> <li>reserved</li> </ul> Default maximum number of extents                                                                                          |
| MAX_SIZE                 | NUMBER       | <ul style="list-style-type: none"> <li>reserved</li> </ul> Default maximum size of segments                                                                                           |
| PCT_INCREASE             | NUMBER       | <ul style="list-style-type: none"> <li>reserved</li> </ul> Default percent increase for extent size                                                                                   |
| MIN_EXTLEN               | NUMBER       | <ul style="list-style-type: none"> <li>reserved</li> </ul> Minimum extent size for this tablespace (in bytes)                                                                         |
| STATUS                   | VARCHAR(32)  | Tablespace status: the value in ( ONLINE, OFFLINE, READ ONLY )                                                                                                                        |
| CONTENTS                 | VARCHAR(32)  | Tablespace contents: the value in ( SYSTEM, DATA, TEMPORARY, UNDO )                                                                                                                   |
| LOGGING                  | VARCHAR(32)  | Default logging attribute: LOGGING, NOLOGGING                                                                                                                                         |
| FORCE_LOGGING            | VARCHAR(3)   | <ul style="list-style-type: none"> <li>reserved</li> </ul> Indicates whether the tablespace is under force logging mode (YES) or not (NO)                                             |
| EXTENT_MANAGEMENT        | VARCHAR(32)  | <ul style="list-style-type: none"> <li>reserved</li> </ul> Indicates whether the extents in the tablespace are dictionary managed (DICTIONARY) or locally managed (LOCAL)             |
| ALLOCATION_TYPE          | VARCHAR(32)  | <ul style="list-style-type: none"> <li>reserved</li> </ul> Type of extent allocation in effect for the tablespace: the value in ( SYSTEM, UNIFORM, USER )                             |
| PLUGGED_IN               | VARCHAR(3)   | <ul style="list-style-type: none"> <li>reserved</li> </ul> Indicates whether the tablespace is plugged in (YES) or not (NO)                                                           |
| SEGMENT_SPACE_MANAGEMENT | VARCHAR(32)  | <ul style="list-style-type: none"> <li>reserved</li> </ul> Indicates whether the free and used segment space in the tablespace is managed using free lists (MANUAL) or bitmaps (AUTO) |
| DEF_TAB_COMPRESSION      | VARCHAR(32)  | <ul style="list-style-type: none"> <li>reserved</li> </ul> Indicates whether default table compression is enabled (ENABLED)                                                           |

| Column name          | Data type   | Description                                                                                                                                              |
|----------------------|-------------|----------------------------------------------------------------------------------------------------------------------------------------------------------|
|                      |             | or not (DISABLED)                                                                                                                                        |
| RETENTION            | VARCHAR(32) | <ul style="list-style-type: none"> <li>reserved</li> </ul> Undo tablespace retention: the value in ( GUARANTEE, NOGUARANTEE, NOT APPLY )                 |
| BIGFILE              | VARCHAR(3)  | <ul style="list-style-type: none"> <li>reserved</li> </ul> Indicates whether the tablespace is a bigfile tablespace (YES) or a smallfile tablespace (NO) |
| PREDICATE_EVALUATION | VARCHAR(32) | <ul style="list-style-type: none"> <li>reserved</li> </ul> Indicates whether predicates are evaluated by host (HOST) or by storage (STORAGE)             |
| ENCRYPTED            | VARCHAR(3)  | <ul style="list-style-type: none"> <li>reserved</li> </ul> Indicates whether the tablespace is encrypted (YES) or not (NO)                               |
| COMPRESS_FOR         | VARCHAR(32) | <ul style="list-style-type: none"> <li>reserved</li> </ul> Indicates whether the tablespace is encrypted (YES) or not (NO)                               |

## DBA\_TAB\_COLS

DBA\_TAB\_COLS describes the columns (including hidden columns) of all tables, views, and clusters in the database.

**Table 9-93** Column information

| Column name          | Data type                          | Description                                                                                                                                                                                                     |
|----------------------|------------------------------------|-----------------------------------------------------------------------------------------------------------------------------------------------------------------------------------------------------------------|
| OWNER                | VARCHAR(128)                       | Owner of the object                                                                                                                                                                                             |
| TABLE_SCHEMA         | VARCHAR(128)                       | Schema of the object                                                                                                                                                                                            |
| TABLE_NAME           | VARCHAR(128)                       | Name of the object                                                                                                                                                                                              |
| COLUMN_NAME          | VARCHAR(128)                       | Column name                                                                                                                                                                                                     |
| DATA_TYPE            | VARCHAR(128)                       | Datatype of the column                                                                                                                                                                                          |
| DATA_TYPE_MOD        | VARCHAR(3)                         | <ul style="list-style-type: none"> <li>reserved</li> </ul> Datatype modifier of the column                                                                                                                      |
| DATA_TYPE_OWNER      | VARCHAR(128)                       | <ul style="list-style-type: none"> <li>reserved</li> </ul> Owner of the datatype of the column                                                                                                                  |
| DATA_LENGTH          | NUMBER                             | Length of the column (in bytes)                                                                                                                                                                                 |
| DATA_PRECISION       | NUMBER                             | Decimal precision for NUMBER datatype; binary precision for FLOAT datatype; NULL for all other datatypes                                                                                                        |
| DATA_SCALE           | NUMBER                             | Digits to the right of the decimal point in a number                                                                                                                                                            |
| NULLABLE             | VARCHAR(1)                         | Indicates whether a column allows NULLs.                                                                                                                                                                        |
| COLUMN_ID            | NUMBER                             | Sequence number of the column as created                                                                                                                                                                        |
| DEFAULT_LENGTH       | NUMBER                             | Length of the default value for the column                                                                                                                                                                      |
| DATA_DEFAULT         | LONG VARCHAR                       | Default value for the column                                                                                                                                                                                    |
| NUM_DISTINCT         | NUMBER                             | Number of distinct values in the column                                                                                                                                                                         |
| LOW_VALUE            | VARBINARY(32)                      | Low value in the column                                                                                                                                                                                         |
| HIGH_VALUE           | VARBINARY(32)                      | High value in the column                                                                                                                                                                                        |
| DENSITY              | NUMBER                             | <ul style="list-style-type: none"> <li>reserved</li> </ul> If a histogram is available on COLUMN_NAME, then this column displays the selectivity of a value that spans fewer than 2 endpoints in the histogram. |
| NUM_NULLS            | NUMBER                             | Number of NULLs in the column                                                                                                                                                                                   |
| NUM_BUCKETS          | NUMBER                             | <ul style="list-style-type: none"> <li>reserved</li> </ul> Number of buckets in the histogram for the column                                                                                                    |
| LAST_ANALYZED        | TIMESTAMP(6) WITH<br>OUT TIME ZONE | Date on which this column was most recently analyzed                                                                                                                                                            |
| SAMPLE_SIZE          | NUMBER                             | Sample size used in analyzing this column                                                                                                                                                                       |
| CHARACTER_SET_NAME   | VARCHAR(128)                       | <ul style="list-style-type: none"> <li>reserved</li> </ul> Name of the character set                                                                                                                            |
| CHAR_COL_DECL_LENGTH | NUMBER                             | Declaration length of the character type column                                                                                                                                                                 |
|                      |                                    | <ul style="list-style-type: none"> <li>reserved</li> </ul>                                                                                                                                                      |



| Column name           | Data type     | Description                                                                                                                                                        |
|-----------------------|---------------|--------------------------------------------------------------------------------------------------------------------------------------------------------------------|
| GLOBAL_STATS          | VARCHAR(3)    | For partitioned tables, indicates whether column statistics were collected for the table                                                                           |
| USER_STATS            | VARCHAR(3)    | <ul style="list-style-type: none"> <li>reserved</li> </ul> Indicates whether statistics were entered directly by the user (YES) or not (NO)                        |
| AVG_COL_LEN           | NUMBER        | Average length of the column (in bytes)                                                                                                                            |
| CHAR_LENGTH           | NUMBER        | Displays the length of the column in characters.                                                                                                                   |
| CHAR_USED             | VARCHAR(1)    | Indicates that the column uses BYTE length semantics (B) or CHAR length semantics (C)                                                                              |
| V80_FMT_IMAGE         | VARCHAR(3)    | <ul style="list-style-type: none"> <li>reserved</li> </ul> Indicates whether the column data is in release older image format (YES) or not (NO)                    |
| DATA_UPGRADED         | VARCHAR(3)    | <ul style="list-style-type: none"> <li>reserved</li> </ul> Indicates whether the column data has been upgraded to the latest type version format (YES) or not (NO) |
| HIDDEN_COLUMN         | VARCHAR(3)    | Indicates whether the column is a hidden column (YES) or not (NO)                                                                                                  |
| VIRTUAL_COLUMN        | VARCHAR(3)    | <ul style="list-style-type: none"> <li>reserved</li> </ul> Indicates whether the column is a virtual column (YES) or not (NO)                                      |
| SEGMENT_COLUMN_ID     | NUMBER        | Sequence number of the column in the segment                                                                                                                       |
| INTERNAL_COLUMN_ID    | NUMBER        | Internal sequence number of the column                                                                                                                             |
| HISTOGRAM             | VARCHAR(32)   | <ul style="list-style-type: none"> <li>reserved</li> </ul> Indicates existence/type of histogram                                                                   |
| QUALIFIED_COLUMN_NAME | VARCHAR(4000) | Qualified column name                                                                                                                                              |
| IDENTITY_COLUMN       | VARCHAR(3)    | Indicates whether this is an identity column (YES) or not (NO)                                                                                                     |

## DBA\_TAB\_COLUMNS

DBA\_TAB\_COLUMNS describes the columns of the tables, views, and clusters accessible to the current user.

**Table 9-94** Column information

| Column name          | Data type                          | Description                                                                                                                                                                                                     |
|----------------------|------------------------------------|-----------------------------------------------------------------------------------------------------------------------------------------------------------------------------------------------------------------|
| OWNER                | VARCHAR(128)                       | Owner of the object                                                                                                                                                                                             |
| TABLE_SCHEMA         | VARCHAR(128)                       | Schema of the object                                                                                                                                                                                            |
| TABLE_NAME           | VARCHAR(128)                       | Name of the object                                                                                                                                                                                              |
| COLUMN_NAME          | VARCHAR(128)                       | Column name                                                                                                                                                                                                     |
| DATA_TYPE            | VARCHAR(128)                       | Datatype of the column                                                                                                                                                                                          |
| DATA_TYPE_MOD        | VARCHAR(3)                         | <ul style="list-style-type: none"> <li>reserved</li> </ul> Datatype modifier of the column                                                                                                                      |
| DATA_TYPE_OWNER      | VARCHAR(128)                       | <ul style="list-style-type: none"> <li>reserved</li> </ul> Owner of the datatype of the column                                                                                                                  |
| DATA_LENGTH          | NUMBER                             | Length of the column (in bytes)                                                                                                                                                                                 |
| DATA_PRECISION       | NUMBER                             | Decimal precision for NUMBER datatype; binary precision for FLOAT datatype; NULL for all other datatypes                                                                                                        |
| DATA_SCALE           | NUMBER                             | Digits to the right of the decimal point in a number                                                                                                                                                            |
| NULLABLE             | VARCHAR(1)                         | Indicates whether a column allows NULLs.                                                                                                                                                                        |
| COLUMN_ID            | NUMBER                             | Sequence number of the column as created                                                                                                                                                                        |
| DEFAULT_LENGTH       | NUMBER                             | Length of the default value for the column                                                                                                                                                                      |
| DATA_DEFAULT         | LONG VARCHAR                       | Default value for the column                                                                                                                                                                                    |
| NUM_DISTINCT         | NUMBER                             | Number of distinct values in the column                                                                                                                                                                         |
| LOW_VALUE            | VARBINARY(32)                      | Low value in the column                                                                                                                                                                                         |
| HIGH_VALUE           | VARBINARY(32)                      | High value in the column                                                                                                                                                                                        |
| DENSITY              | NUMBER                             | <ul style="list-style-type: none"> <li>reserved</li> </ul> If a histogram is available on COLUMN_NAME, then this column displays the selectivity of a value that spans fewer than 2 endpoints in the histogram. |
| NUM_NULLS            | NUMBER                             | Number of NULLs in the column                                                                                                                                                                                   |
| NUM_BUCKETS          | NUMBER                             | <ul style="list-style-type: none"> <li>reserved</li> </ul> Number of buckets in the histogram for the column                                                                                                    |
| LAST_ANALYZED        | TIMESTAMP(6) WITH<br>OUT TIME ZONE | Date on which this column was most recently analyzed                                                                                                                                                            |
| SAMPLE_SIZE          | NUMBER                             | Sample size used in analyzing this column                                                                                                                                                                       |
| CHARACTER_SET_NAME   | VARCHAR(128)                       | <ul style="list-style-type: none"> <li>reserved</li> </ul> Name of the character set                                                                                                                            |
| CHAR_COL_DECL_LENGTH | NUMBER                             | Declaration length of the character type column                                                                                                                                                                 |
|                      |                                    | <ul style="list-style-type: none"> <li>reserved</li> </ul>                                                                                                                                                      |

| Column name     | Data type   | Description                                                                                                                                                        |
|-----------------|-------------|--------------------------------------------------------------------------------------------------------------------------------------------------------------------|
| GLOBAL_STATS    | VARCHAR(3)  | For partitioned tables, indicates whether column statistics were collected for the table                                                                           |
| USER_STATS      | VARCHAR(3)  | <ul style="list-style-type: none"> <li>reserved</li> </ul> Indicates whether statistics were entered directly by the user (YES) or not (NO)                        |
| AVG_COL_LEN     | NUMBER      | Average length of the column (in bytes)                                                                                                                            |
| CHAR_LENGTH     | NUMBER      | Displays the length of the column in characters.                                                                                                                   |
| CHAR_USED       | VARCHAR(1)  | Indicates that the column uses BYTE length semantics (B) or CHAR length semantics (C)                                                                              |
| V80_FMT_IMAGE   | VARCHAR(3)  | <ul style="list-style-type: none"> <li>reserved</li> </ul> Indicates whether the column data is in release older image format (YES) or not (NO)                    |
| DATA_UPGRADED   | VARCHAR(3)  | <ul style="list-style-type: none"> <li>reserved</li> </ul> Indicates whether the column data has been upgraded to the latest type version format (YES) or not (NO) |
| HISTOGRAM       | VARCHAR(32) | <ul style="list-style-type: none"> <li>reserved</li> </ul> Indicates existence/type of histogram                                                                   |
| IDENTITY_COLUMN | VARCHAR(3)  | Indicates whether this is an identity column (YES) or not (NO)                                                                                                     |

## DBA\_TAB\_COMMENTS

DBA\_TAB\_COMMENTS displays comments on all tables and views in the database.

**Table 9-95** Column information

| Column name  | Data type     | Description           |
|--------------|---------------|-----------------------|
| OWNER        | VARCHAR(128)  | Owner of the object   |
| TABLE_SCHEMA | VARCHAR(128)  | Schema of the object  |
| TABLE_NAME   | VARCHAR(128)  | Name of the object    |
| TABLE_TYPE   | VARCHAR(32)   | Type of the object    |
| COMMENTS     | VARCHAR(1024) | Comment on the object |

## DBA\_TAB\_IDENTITY\_COLS

DBA\_TAB\_IDENTITY\_COLS describes all table identity columns.

**Table 9-96** Column information

| Column name      | Data type     | Description                                                                      |
|------------------|---------------|----------------------------------------------------------------------------------|
| OWNER            | VARCHAR(128)  | Owner of the table                                                               |
| TABLE_SCHEMA     | VARCHAR(128)  | Schema of the table                                                              |
| TABLE_NAME       | VARCHAR(128)  | Name of the table                                                                |
| COLUMN_NAME      | VARCHAR(128)  | Name of the identity column                                                      |
| GENERATION_TYPE  | VARCHAR(32)   | Generation type of the identity column. Possible values are ALWAYS or BY DEFAULT |
| IDENTITY_OPTIONS | VARCHAR(1024) | Options for the identity column sequence generator                               |

## DBA\_TAB\_PLACE

DBA\_TAB\_PLACE describes node placement of all cluster tables in the cluster system.



It is available only on a cluster.

**Table 9-97** Column information

| Column name      | Data type                          | Description                                                                              |
|------------------|------------------------------------|------------------------------------------------------------------------------------------|
| OWNER            | VARCHAR(128)                       | Owner of the table                                                                       |
| TABLE_SCHEMA     | VARCHAR(128)                       | Schema of the table                                                                      |
| TABLE_NAME       | VARCHAR(128)                       | Name of the table                                                                        |
| GROUP_ID         | NUMBER                             | Group identifier of the node where the table placed                                      |
| GROUP_NAME       | VARCHAR(128)                       | Group name of the node where the table placed                                            |
| MEMBER_ID        | NUMBER                             | Member identifier of the node where the table placed                                     |
| MEMBER_NAME      | VARCHAR(128)                       | Member name of the node where the table placed                                           |
| MEMBER_POSITION  | NUMBER                             | Member position of the node where the table placed                                       |
| MEMBER_OFFLINE   | BOOLEAN                            | data of the cluster member is offline or not                                             |
| IS_UPDATE_MASTER | BOOLEAN                            | whether the cluster member is update master or not                                       |
| DROPPED          | VARCHAR(3)                         | Indicates whether the table has been dropped and is in the recycle bin (YES) or not (NO) |
| SCN              | VARCHAR(64)                        | table scn of the node where the table placed                                             |
| NUM_ROWS         | NUMBER                             | Number of rows in the table                                                              |
| BLOCKS           | NUMBER                             | Number of used blocks of the node where the table placed                                 |
| LAST_ANALYZED    | TIMESTAMP(6) WITH<br>OUT TIME ZONE | Date on which the table was most recently analyzed                                       |

## DBA\_TAB\_PRIVS

DBA\_TAB\_PRIVS describes all object grants in the database.

**Table 9-98** Column information

| Column name  | Data type    | Description                                                                             |
|--------------|--------------|-----------------------------------------------------------------------------------------|
| GRANTEE      | VARCHAR(128) | Name of the user or role to whom access was granted                                     |
| OWNER        | VARCHAR(128) | Owner of the object                                                                     |
| TABLE_SCHEMA | VARCHAR(128) | Schema of the object                                                                    |
| TABLE_NAME   | VARCHAR(128) | Name of the object                                                                      |
| GRANTOR      | VARCHAR(128) | Name of the user who performed the grant                                                |
| PRIVILEGE    | VARCHAR(32)  | Privilege on the object                                                                 |
| GRANTABLE    | VARCHAR(3)   | Indicates whether the privilege was granted with the GRANT OPTION (YES) or not (NO)     |
| HIERARCHY    | VARCHAR(3)   | Indicates whether the privilege was granted with the HIERARCHY OPTION (YES) or not (NO) |

## DBA\_TAB\_SHARDS

DBA\_TAB\_SHARDS describes shard information of all sharded tables in the cluster system.



It is available only on a cluster.

**Table 9-99** Column information

| Column name      | Data type    | Description                                                                                    |
|------------------|--------------|------------------------------------------------------------------------------------------------|
| OWNER            | VARCHAR(128) | Owner of the table                                                                             |
| TABLE_SCHEMA     | VARCHAR(128) | Schema of the table                                                                            |
| TABLE_NAME       | VARCHAR(128) | Name of the table                                                                              |
| SHARD_STRATEGY   | VARCHAR(32)  | Sharding strategy of the table:<br>the value in (HASH SHARDING, RANGE SHARDING, LIST SHARDING) |
| SHARD_NAME       | VARCHAR(128) | Shard name                                                                                     |
| SHARD_NUMBER     | NUMBER       | Shard number                                                                                   |
| SHARD_DEFINITION | LONG VARCHAR | Shard definition (if hash sharded, the value is null)                                          |
| GROUP_ID         | NUMBER       | Group identifier where the shard placed                                                        |
| GROUP_NAME       | VARCHAR(128) | Group Name where the shard placed                                                              |
| DROPPED          | VARCHAR(3)   | Indicates whether the table has been dropped and is in the recycle bin (YES) or not (NO)       |



## DBA\_TBS\_PRIVS

DBA\_TBS\_PRIVS describes all tablespace grants in the database.

**Table 9-100** Column information

| Column name     | Data type    | Description                                                                         |
|-----------------|--------------|-------------------------------------------------------------------------------------|
| GRANTOR         | VARCHAR(128) | Name of the user who performed the grant                                            |
| GRANTEE         | VARCHAR(128) | Name of the user or role to whom access was granted                                 |
| TABLESPACE_NAME | VARCHAR(128) | Name of the tablespace                                                              |
| PRIVILEGE       | VARCHAR(32)  | Privilege on the tablespace                                                         |
| GRANTABLE       | VARCHAR(3)   | Indicates whether the privilege was granted with the GRANT OPTION (YES) or not (NO) |

## DBA\_USERS

DBA\_USERS describes all users of the database.

**Table 9-101** Column information

| Column name                         | Data type                             | Description                                                                                                                                                                                       |
|-------------------------------------|---------------------------------------|---------------------------------------------------------------------------------------------------------------------------------------------------------------------------------------------------|
| USERNAME                            | VARCHAR(128)                          | Name of the user                                                                                                                                                                                  |
| USER_ID                             | NUMBER                                | ID number of the user                                                                                                                                                                             |
| PASSWORD                            | VARCHAR(128)                          | encrypted password                                                                                                                                                                                |
| ACCOUNT_STAT<br>US                  | VARCHAR(32)                           | Account status: the value in ( OPEN, EXPIRED, EXPIRED(GRACE), LOCKED(T<br>IMED), LOCKED, EXPIRED & LOCKED(TIMED), EXPIRED(GRACE) & LOCKED<br>(TIMED), EXPIRED & LOCKED, EXPIRED(GRACE) & LOCKED ) |
| LOCK_DATE                           | TIMESTAMP(2)<br>WITHOUT TIME Z<br>ONE | Timestamp the account was locked if account status was LOCKED                                                                                                                                     |
| EXPIRY_DATE                         | TIMESTAMP(2)<br>WITHOUT TIME Z<br>ONE | Timestamp of expiration of the account                                                                                                                                                            |
| FAILED_LOGIN_A<br>TTEMPTS           | NUMBER                                | Consecutive failed login attempts count                                                                                                                                                           |
| DEFAULT_TABLE<br>SPACE              | VARCHAR(128)                          | Default tablespace for data                                                                                                                                                                       |
| TEMPORARY_TA<br>BLESPEACE           | VARCHAR(128)                          | Name of the default tablespace for temporary tables or the name of a tables<br>pace group                                                                                                         |
| INDEX_TABLESP<br>ACE                | VARCHAR(128)                          | Default tablespace for index                                                                                                                                                                      |
| CREATED                             | TIMESTAMP(2)<br>WITHOUT TIME Z<br>ONE | User creation timestamp                                                                                                                                                                           |
| PROFIL_NAME                         | VARCHAR(128)                          | User resource profile name                                                                                                                                                                        |
| INITIAL_RSRC_C<br>ONSUMER_GRO<br>UP | VARCHAR(128)                          | <ul style="list-style-type: none"> <li>reserved</li> </ul> Initial resource consumer group for the user                                                                                           |
| EXTERNAL_NAM<br>E                   | VARCHAR(128)                          | <ul style="list-style-type: none"> <li>reserved</li> </ul> User external name                                                                                                                     |
| PASSWORD_VER<br>SIONS               | VARCHAR(32)                           | <ul style="list-style-type: none"> <li>reserved</li> </ul> Shows the list of versions of the password hashes (verifiers).                                                                         |
| EDITIONS_ENABL<br>ED                | VARCHAR(1)                            | Indicates whether editions have been enabled for the corresponding user (Y<br>) or not (N).                                                                                                       |
| AUTHENTICATIO<br>N_TYPE             | VARCHAR(32)                           | <ul style="list-style-type: none"> <li>reserved</li> </ul> Indicates the authentication mechanism for the user.                                                                                   |

## DBA\_VIEWS

DBA\_VIEWS describes all views in the database.

**Table 9-102** Column information

| Column name      | Data type     | Description                                                                                                          |
|------------------|---------------|----------------------------------------------------------------------------------------------------------------------|
| OWNER            | VARCHAR(128)  | Owner of the view                                                                                                    |
| VIEW_SCHEMA      | VARCHAR(128)  | Schema of the view                                                                                                   |
| VIEW_NAME        | VARCHAR(128)  | Name of the view                                                                                                     |
| TEXT_LENGTH      | NUMBER        | Length of the view text                                                                                              |
| TEXT             | LONG VARCHAR  | View text                                                                                                            |
| TYPE_TEXT_LENGTH | NUMBER        | <ul style="list-style-type: none"> <li>reserved</li> </ul> Length of the type clause of the typed view               |
| TYPE_TEXT        | VARCHAR(4000) | <ul style="list-style-type: none"> <li>reserved</li> </ul> Type clause of the typed view                             |
| OID_TEXT_LENGTH  | NUMBER        | <ul style="list-style-type: none"> <li>reserved</li> </ul> Length of the WITH OID clause of the typed view           |
| OID_TEXT         | VARCHAR(4000) | <ul style="list-style-type: none"> <li>reserved</li> </ul> WITH OID clause of the typed view                         |
| VIEW_TYPE_OWNER  | VARCHAR(128)  | <ul style="list-style-type: none"> <li>reserved</li> </ul> Owner of the type of the view if the view is a typed view |
| VIEW_TYPE        | VARCHAR(32)   | <ul style="list-style-type: none"> <li>reserved</li> </ul> Type of the view if the view is a typed view              |
| SUPERVIEW_NAME   | VARCHAR(128)  | <ul style="list-style-type: none"> <li>reserved</li> </ul> Name of the superview                                     |
| EDITIONING_VIEW  | VARCHAR(1)    | Reserved for future use                                                                                              |
| READ_ONLY        | VARCHAR(1)    | Indicates whether the view is read-only (Y) or not (N)                                                               |

## Views of USER\_family

It retrieves information about objects which are owned by current user.

### USER\_ALL\_TABLES

USER\_ALL\_TABLES describes the object tables and relational tables owned by the current user.

**Table 9-103** Column information

| Column name     | Data type    | Description                                                                                                                                                               |
|-----------------|--------------|---------------------------------------------------------------------------------------------------------------------------------------------------------------------------|
| TABLE_SCHEMA    | VARCHAR(128) | Schema of the table                                                                                                                                                       |
| TABLE_NAME      | VARCHAR(128) | Name of the table                                                                                                                                                         |
| TABLESPACE_NAME | VARCHAR(128) | Name of the tablespace containing the table                                                                                                                               |
| CLUSTER_NAME    | VARCHAR(128) | <ul style="list-style-type: none"> <li>reserved</li> </ul> Name of the cluster                                                                                            |
| IOT_NAME        | VARCHAR(128) | <ul style="list-style-type: none"> <li>reserved</li> </ul> Name of the index-organized table                                                                              |
| STATUS          | VARCHAR(32)  | <ul style="list-style-type: none"> <li>reserved</li> </ul> If a previous DROP TABLE operation failed, indicates whether the table is unusable (UNUSABLE) or valid (VALID) |
| PCT_FREE        | NUMBER       | Minimum percentage of free space in a block                                                                                                                               |
| PCT_USED        | NUMBER       | Minimum percentage of used space in a block                                                                                                                               |
| INI_TRANS       | NUMBER       | Initial number of transactions                                                                                                                                            |
| MAX_TRANS       | NUMBER       | Maximum number of transactions                                                                                                                                            |
| INITIAL_EXTENT  | NUMBER       | Size of the initial extent (in bytes)                                                                                                                                     |
| NEXT_EXTENT     | NUMBER       | Size of secondary extents (in bytes)                                                                                                                                      |
| MIN_EXTENTS     | NUMBER       | Minimum number of extents allowed in the segment                                                                                                                          |
| MAX_EXTENTS     | NUMBER       | Maximum number of extents allowed in the segment                                                                                                                          |
| PCT_INCREASE    | NUMBER       | <ul style="list-style-type: none"> <li>reserved</li> </ul> Percentage increase in extent size                                                                             |
| FREELISTS       | NUMBER       | <ul style="list-style-type: none"> <li>reserved</li> </ul> Number of process freelists allocated to the segment                                                           |
| FREELIST_GROUPS | NUMBER       | <ul style="list-style-type: none"> <li>reserved</li> </ul> Number of freelist groups allocated to the segment                                                             |
| LOGGING         | VARCHAR(3)   | Indicates whether or not changes to the table are logged                                                                                                                  |
| BACKED_UP       | VARCHAR(1)   | <ul style="list-style-type: none"> <li>reserved</li> </ul> Indicates whether the table has been backed up since the last modification (Y) or not (N)                      |
| NUM_ROWS        | NUMBER       | Number of rows in the table                                                                                                                                               |
| BLOCKS          | NUMBER       | Number of used blocks in the table                                                                                                                                        |

| Column name               | Data type                      | Description                                                                                                                                                                                                             |
|---------------------------|--------------------------------|-------------------------------------------------------------------------------------------------------------------------------------------------------------------------------------------------------------------------|
| EMPTY_BLOCKS              | NUMBER                         | <ul style="list-style-type: none"> <li>reserved</li> </ul> Number of empty (never used) blocks in the table                                                                                                             |
| AVG_SPACE                 | NUMBER                         | <ul style="list-style-type: none"> <li>reserved</li> </ul> Average available free space in the table                                                                                                                    |
| CHAIN_CNT                 | NUMBER                         | <ul style="list-style-type: none"> <li>reserved</li> </ul> Number of rows in the table that are chained from one data block to another or that have migrated to a new block, requiring a link to preserve the old rowid |
| AVG_ROW_LEN               | NUMBER                         | <ul style="list-style-type: none"> <li>reserved</li> </ul> Average row length, including row overhead                                                                                                                   |
| AVG_SPACE_FREELIST_BLOCKS | NUMBER                         | <ul style="list-style-type: none"> <li>reserved</li> </ul> Average freespace of all blocks on a freelist                                                                                                                |
| NUM_FREELIST_BLOCKS       | NUMBER                         | <ul style="list-style-type: none"> <li>reserved</li> </ul> Number of blocks on the freelist                                                                                                                             |
| DEGREE                    | VARCHAR(32)                    | <ul style="list-style-type: none"> <li>reserved</li> </ul> Number of threads per instance for scanning the table, or DEFAULT                                                                                            |
| INSTANCES                 | VARCHAR(32)                    | <ul style="list-style-type: none"> <li>reserved</li> </ul> Number of instances across which the table is to be scanned, or DEFAULT                                                                                      |
| CACHE                     | VARCHAR(1)                     | <ul style="list-style-type: none"> <li>reserved</li> </ul> Indicates whether the table is to be cached in the buffer cache (Y) or not (N)                                                                               |
| TABLE_LOCK                | VARCHAR(32)                    | Indicates whether table locking is enabled (ENABLED) or disabled (DISABLED)                                                                                                                                             |
| SAMPLE_SIZE               | NUMBER                         | Sample size used in analyzing the table                                                                                                                                                                                 |
| LAST_ANALYZED             | TIMESTAMP(6) WITHOUT TIME ZONE | Date on which the table was most recently analyzed                                                                                                                                                                      |
| PARTITIONED               | VARCHAR(3)                     | <ul style="list-style-type: none"> <li>reserved</li> </ul> Indicates whether the table is partitioned (YES) or not (NO)                                                                                                 |
| IOT_TYPE                  | VARCHAR(32)                    | <ul style="list-style-type: none"> <li>reserved</li> </ul> If the table is an index-organized table, then IOT_TYPE is IOT, IOT_OVERFLOW, or IOT_MAPPING.                                                                |
| OBJECT_ID_TYPE            | VARCHAR(32)                    | <ul style="list-style-type: none"> <li>reserved</li> </ul> Indicates whether the object ID (OID) is USER-DEFINED or SYSTEM GENERATED                                                                                    |
| TABLE_TYPE_OWNER          | VARCHAR(128)                   | <ul style="list-style-type: none"> <li>reserved</li> </ul> If an object table, owner of the type from which the table is created                                                                                        |
| TABLE_TYPE                | VARCHAR(128)                   | <ul style="list-style-type: none"> <li>reserved</li> </ul> If an object table, type of the table                                                                                                                        |
| TEMPORARY                 | VARCHAR(1)                     | Indicates whether the table is temporary (Y) or not (N)                                                                                                                                                                 |
|                           |                                | <ul style="list-style-type: none"> <li>reserved</li> </ul>                                                                                                                                                              |

| Column name      | Data type    | Description                                                                                                                                                                              |
|------------------|--------------|------------------------------------------------------------------------------------------------------------------------------------------------------------------------------------------|
| SECONDARY        | VARCHAR(1)   | Indicates whether the table is a secondary object created by cartridge                                                                                                                   |
| NESTED           | VARCHAR(3)   | <ul style="list-style-type: none"> <li>reserved</li> </ul> Indicates whether the table is a nested table (YES) or not (NO)                                                               |
| BUFFER_POOL      | VARCHAR(32)  | <ul style="list-style-type: none"> <li>reserved</li> </ul> Buffer pool to be used for table blocks                                                                                       |
| FLASH_CACHE      | VARCHAR(32)  | <ul style="list-style-type: none"> <li>reserved</li> </ul> Database Smart Flash Cache hint to be used for table blocks                                                                   |
| CELL_FLASH_CACHE | VARCHAR(32)  | <ul style="list-style-type: none"> <li>reserved</li> </ul> Cell flash cache hint to be used for table blocks                                                                             |
| ROW_MOVEMENT     | VARCHAR(32)  | <ul style="list-style-type: none"> <li>reserved</li> </ul> If a partitioned table, indicates whether row movement is enabled (ENABLED) or disabled (DISABLED)                            |
| GLOBAL_STATS     | VARCHAR(3)   | <ul style="list-style-type: none"> <li>reserved</li> </ul> For partitioned tables, indicates whether statistics for the table as a whole (global statistics) are accurate (YES)          |
| USER_STATS       | VARCHAR(3)   | <ul style="list-style-type: none"> <li>reserved</li> </ul> Indicates whether statistics were entered directly by the user (YES) or not (NO)                                              |
| DURATION         | VARCHAR(32)  | Indicates the duration of a temporary table, the value is in ( TRANSACTION, SESSION )                                                                                                    |
| SKIP_CORRUPT     | VARCHAR(32)  | <ul style="list-style-type: none"> <li>reserved</li> </ul> Indicates whether Database ignores blocks marked corrupt during table and index scans (ENABLED) or raises an error (DISABLED) |
| MONITORING       | VARCHAR(3)   | <ul style="list-style-type: none"> <li>reserved</li> </ul> Indicates whether the table has the MONITORING attribute set (YES) or not (NO)                                                |
| CLUSTER_OWNER    | VARCHAR(128) | <ul style="list-style-type: none"> <li>reserved</li> </ul> Owner of the cluster, if any                                                                                                  |
| DEPENDENCIES     | VARCHAR(32)  | <ul style="list-style-type: none"> <li>reserved</li> </ul> Indicates whether row-level dependency tracking is enabled (ENABLED) or disabled (DISABLED)                                   |
| COMPRESSION      | VARCHAR(32)  | <ul style="list-style-type: none"> <li>reserved</li> </ul> Indicates whether table compression is enabled (ENABLED) or not (DISABLED)                                                    |
| COMPRESS_FOR     | VARCHAR(32)  | <ul style="list-style-type: none"> <li>reserved</li> </ul> Default compression for what kind of operations                                                                               |
| DROPPED          | VARCHAR(3)   | Indicates whether the table has been dropped and is in the recycle bin (YES) or not (NO)                                                                                                 |
| READ_ONLY        | VARCHAR(3)   | Indicates whether the table IS READ-ONLY (YES) or not (NO)                                                                                                                               |
| SEGMENT_CREATED  | VARCHAR(3)   | Indicates whether the table segment has been created (YES) or not                                                                                                                        |

| Column name | Data type | Description |
|-------------|-----------|-------------|
|             |           | (NO)        |

## USER\_ARGUMENTS

USER\_ARGUMENTS lists all arguments of functions, procedures.

**Table 9-104** Column information

| Column name        | Data type    | Description                                                           |
|--------------------|--------------|-----------------------------------------------------------------------|
| SCHEMA_NAME        | VARCHAR(128) | Schema Name of function, procedures or package                        |
| OBJECT_NAME        | VARCHAR(128) | Name of function, procedures                                          |
| PACKAGE_NAME       | VARCHAR(128) | Package Name of function, procedures                                  |
| OBJECT_ID          | NUMBER       | ID of a function, procedures                                          |
| SUBPROGRAM_ID      | NUMBER       | ID of procedures in package                                           |
| ARGUMENT_NAME      | VARCHAR(128) | Name of argument or attribute name of record type argument            |
| POSITION           | NUMBER       | Position of argument or position of attribute in record type          |
| SEQUENCE           | NUMBER       | Sequential order of argument and its attributes                       |
| DATA_LEVEL         | NUMBER       | Nesting depth of the argument for composite types                     |
| DATA_TYPE          | VARCHAR(128) | Data type of the argument                                             |
| DEFAULTED          | VARCHAR(1)   | Whether or not the argument is defaulted                              |
| DEFAULT_VALUE      | VARCHAR(1)   | Reserved for future use                                               |
| DEFAULT_LENGTH     | VARCHAR(1)   | Reserved for future use                                               |
| IN_OUT             | VARCHAR(32)  | Direction of the argument (IN, OUT, IN/OUT)                           |
| DATA_LENGTH        | NUMBER       | Length of the column(in bytes)                                        |
| DATA_PRECISION     | NUMBER       | Length in decimal digits(NUMBER) or binary digits(FLOAT)              |
| DATA_SCALE         | NUMBER       | Digits to the right of the decimal point in a number                  |
| RADIX              | NUMBER       | Argument radix for a number                                           |
| CHARACTER_SET_NAME | VARCHAR(128) | Character set name for the argument                                   |
| TYPE_OWNER         | VARCHAR(128) | Owner of the type of the argument                                     |
| TYPE_NAME          | VARCHAR(128) | Name of the type of the argument                                      |
| TYPE_SUBNAME       | VARCHAR(128) | Name of the type of the argument declared in package                  |
| TYPE_LINK          | VARCHAR(128) | Name of the type of the argument declared in a remote package         |
| PLS_TYPE           | VARCHAR(128) | Name of the type of the argument at PSM                               |
| CHAR_LENGTH        | NUMBER       | Character limit for string datatypes                                  |
| CHAR_USED          | VARCHAR(1)   | Whether the byte limit(B) or char limit(C) is official for the string |
| ORIGIN_CON_ID      | VARCHAR(256) | ID of the container where the data originates                         |



## USER\_CATALOG

USER\_CATALOG lists tables, views, synonyms, and sequences owned by the current user.

**Table 9-105** Column information

| Column name  | Data type    | Description                                                |
|--------------|--------------|------------------------------------------------------------|
| TABLE_SCHEMA | VARCHAR(128) | Schema of the TABLE, VIEW, SYNONYM, SEQUENCE, or UNDEFINED |
| TABLE_NAME   | VARCHAR(128) | Name of the TABLE, VIEW, SYNONYM, SEQUENCE, or UNDEFINED   |
| TABLE_TYPE   | VARCHAR(32)  | Type of the TABLE, VIEW, SYNONYM, SEQUENCE, or UNDEFINED   |

## USER\_COL\_COMMENTS

USER\_COL\_COMMENTS displays comments on the columns of the tables and views owned by the current user.

**Table 9-106** Column information

| Column name  | Data type     | Description           |
|--------------|---------------|-----------------------|
| TABLE_SCHEMA | VARCHAR(128)  | Schema of the object  |
| TABLE_NAME   | VARCHAR(128)  | Name of the object    |
| COLUMN_NAME  | VARCHAR(128)  | Name of the column    |
| COMMENTS     | VARCHAR(1024) | Comment on the column |

## USER\_CLUSTER\_TABLES

USER\_CLUSTER\_TABLES describes all cluster tables owned by the current user in the cluster system.



It is available only on a cluster.

**Table 9-107** Column information

| Column name     | Data type    | Description                                                                                            |
|-----------------|--------------|--------------------------------------------------------------------------------------------------------|
| TABLE_SCHEMA    | VARCHAR(128) | Schema of the table                                                                                    |
| TABLE_NAME      | VARCHAR(128) | Name of the table                                                                                      |
| SHARD_STRATEGY  | VARCHAR(32)  | Sharding strategy of the table:<br>the value in (CLONED, HASH SHARDING, RANGE SHARDING, LIST SHARDING) |
| SHARD_PLACEMENT | VARCHAR(32)  | Shard placement of the table:<br>the value in (AT CLUSTER WIDE or AT CLUSTER GROUP)                    |
| SHARD_COUNT     | NUMBER       | Shard count of the table (if cloned table, the value is null)                                          |
| SHARD_KEY_COUNT | NUMBER       | Shard key column count of the table (if cloned table, the value is null)                               |
| HAS_GSI         | VARCHAR(3)   | Indicate whether the table has global secondary index: (YES) or (NO)                                   |
| DROPPED         | VARCHAR(3)   | Indicates whether the table has been dropped and is in the recycle bin (YES) or not (NO)               |

## USER\_COL\_PRIVS

USER\_COL\_PRIVS describes the column object grants for which the current user is the object owner, grantor, or grantee.

**Table 9-108** Column information

| Column name  | Data type    | Description                                                                         |
|--------------|--------------|-------------------------------------------------------------------------------------|
| GRANTEE      | VARCHAR(128) | Name of the user or role to whom access was granted                                 |
| OWNER        | VARCHAR(128) | Owner of the object                                                                 |
| TABLE_SCHEMA | VARCHAR(128) | Schema of the object                                                                |
| TABLE_NAME   | VARCHAR(128) | Name of the object                                                                  |
| COLUMN_NAME  | VARCHAR(128) | Name of the column                                                                  |
| GRANTOR      | VARCHAR(128) | Name of the user who performed the grant                                            |
| PRIVILEGE    | VARCHAR(32)  | Privilege on the column                                                             |
| GRANTABLE    | VARCHAR(3)   | Indicates whether the privilege was granted with the GRANT OPTION (YES) or not (NO) |

## USER\_COL\_PRIVS\_MADE

USER\_COL\_PRIVS\_MADE describes the column object grants for which the current user is the object owner.

**Table 9-109** Column information

| Column name  | Data type    | Description                                                                         |
|--------------|--------------|-------------------------------------------------------------------------------------|
| GRANTEE      | VARCHAR(128) | Name of the user or role to whom access was granted                                 |
| TABLE_SCHEMA | VARCHAR(128) | Schema of the object                                                                |
| TABLE_NAME   | VARCHAR(128) | Name of the object                                                                  |
| COLUMN_NAME  | VARCHAR(128) | Name of the column                                                                  |
| GRANTOR      | VARCHAR(128) | Name of the user who performed the grant                                            |
| PRIVILEGE    | VARCHAR(32)  | Privilege on the column                                                             |
| GRANTABLE    | VARCHAR(3)   | Indicates whether the privilege was granted with the GRANT OPTION (YES) or not (NO) |

## USER\_COL\_PRIVS\_RECD

USER\_COL\_PRIVS\_RECD describes the column object grants for which the current user is the grantee.

**Table 9-110** Column information

| Column name  | Data type    | Description                                                                         |
|--------------|--------------|-------------------------------------------------------------------------------------|
| GRANTEE      | VARCHAR(128) | Name of the user or role to whom access was granted                                 |
| TABLE_SCHEMA | VARCHAR(128) | Schema of the object                                                                |
| TABLE_NAME   | VARCHAR(128) | Name of the object                                                                  |
| COLUMN_NAME  | VARCHAR(128) | Name of the column                                                                  |
| GRANTOR      | VARCHAR(128) | Name of the user who performed the grant                                            |
| PRIVILEGE    | VARCHAR(32)  | Privilege on the column                                                             |
| GRANTABLE    | VARCHAR(3)   | Indicates whether the privilege was granted with the GRANT OPTION (YES) or not (NO) |

## USER\_CONSTRAINTS

USER\_CONSTRAINTS describes all constraint definitions on tables owned by the current user.

**Table 9-111** Column information

| Column name       | Data type                      | Description                                                                                                                                                                         |
|-------------------|--------------------------------|-------------------------------------------------------------------------------------------------------------------------------------------------------------------------------------|
| OWNER             | VARCHAR(128)                   | Owner of the constraint definition                                                                                                                                                  |
| CONSTRAINT_SCHEMA | VARCHAR(128)                   | Schema of the constraint definition                                                                                                                                                 |
| CONSTRAINT_NAME   | VARCHAR(128)                   | Name of the constraint definition                                                                                                                                                   |
| CONSTRAINT_TYPE   | VARCHAR(1)                     | Type of the constraint definition: the value in ( C: check constraint, P: Primary key, U: Unique Key, R: Referential integrity )                                                    |
| TABLE_OWNER       | VARCHAR(128)                   | Owner of the table (or view) associated with the constraint definition                                                                                                              |
| TABLE_SCHEMA      | VARCHAR(128)                   | Schema of the table (or view) associated with the constraint definition                                                                                                             |
| TABLE_NAME        | VARCHAR(128)                   | Name of the table (or view) associated with the constraint definition                                                                                                               |
| SEARCH_CONDITION  | LONG VARCHAR                   | Text of search condition for a check constraint                                                                                                                                     |
| R_OWNER           | VARCHAR(128)                   | Owner of the unique constraint definition for the referenced table                                                                                                                  |
| R_SCHEMA          | VARCHAR(128)                   | Schema of the unique constraint definition for the referenced table                                                                                                                 |
| R_CONSTRAINT_NAME | VARCHAR(128)                   | Name of the unique constraint definition for the referenced table                                                                                                                   |
| DELETE_RULE       | VARCHAR(32)                    | Delete rule for a referential constraint: the value in ( NO ACTION, RESTRICT, CASCADE, SET NULL, SET DEFAULT )                                                                      |
| UPDATE_RULE       | VARCHAR(32)                    | Update rule for a referential constraint: the value in ( NO ACTION, RESTRICT, CASCADE, SET NULL, SET DEFAULT )                                                                      |
| STATUS            | VARCHAR(32)                    | Enforcement status of the constraint: the value in ( ENABLED, DISABLE )                                                                                                             |
| DEFERRABLE        | VARCHAR(32)                    | Indicates whether the constraint is deferrable (DEFERRABLE) or not (NOT DEFERRABLE)                                                                                                 |
| DEFERRED          | VARCHAR(32)                    | Indicates whether the constraint was initially deferred (DEFERRED) or not (IMMEDIATE)                                                                                               |
| VALIDATED         | VARCHAR(32)                    | Indicates whether all data may obey the constraint or not: the value in ( VALIDATED, NOT VALIDATED )                                                                                |
| GENERATED         | VARCHAR(32)                    | Indicates whether the name of the constraint is user-generated (USER NAME) or system-generated (GENERATED NAME)                                                                     |
| BAD               | VARCHAR(32)                    | <ul style="list-style-type: none"> <li>reserved</li> </ul> Indicates whether this constraint specifies a century in an ambiguous manner (BAD) or not (NULL)                         |
| RELY              | VARCHAR(32)                    | <ul style="list-style-type: none"> <li>reserved</li> </ul> When NOT VALIDATED, indicates whether the constraint is to be taken in to account for query rewrite (RELY) or not (NULL) |
| LAST_CHANGE       | TIMESTAMP(2) WITHOUT TIME ZONE | When the constraint was last enabled or disabled                                                                                                                                    |

| Column name  | Data type     | Description                                                                                                                                  |
|--------------|---------------|----------------------------------------------------------------------------------------------------------------------------------------------|
| INDEX_OWNER  | VARCHAR(128)  | Owner of the index associated with the key constraint                                                                                        |
| INDEX_SCHEMA | VARCHAR(128)  | Schema of the index associated with the key constraint                                                                                       |
| INDEX_NAME   | VARCHAR(128)  | Name of the index associated with the key constraint                                                                                         |
| INVALID      | VARCHAR(32)   | Indicates whether the constraint is invalid (INVALID) or not (NULL)                                                                          |
| VIEW_RELATED | VARCHAR(32)   | <ul style="list-style-type: none"> <li>reserved</li> </ul> Indicates whether the constraint depends on a view (DEPEND ON VIEW) or not (NULL) |
| DROPPED      | VARCHAR(3)    | Indicates whether the constraint has been dropped and is in the recycle bin (YES) or not (NO)                                                |
| COMMENTS     | VARCHAR(1024) | Comments of the constraint definition                                                                                                        |



## USER\_CONS\_COLUMNS

USER\_CONS\_COLUMNS describes columns that are owned by the current user and that are specified in constraint definitions.

**Table 9-112** Column information

| Column name       | Data type    | Description                                                                                      |
|-------------------|--------------|--------------------------------------------------------------------------------------------------|
| OWNER             | VARCHAR(128) | Owner of the constraint definition                                                               |
| CONSTRAINT_SCHEMA | VARCHAR(128) | Schema of the constraint definition                                                              |
| CONSTRAINT_NAME   | VARCHAR(128) | Name of the constraint definition                                                                |
| TABLE_OWNER       | VARCHAR(128) | Owner of the table with the constraint definition                                                |
| TABLE_SCHEMA      | VARCHAR(128) | Schema of the table with the constraint definition                                               |
| TABLE_NAME        | VARCHAR(128) | Name of the table with the constraint definition                                                 |
| COLUMN_NAME       | VARCHAR(128) | Name of the column or attribute of the object type column specified in the constraint definition |
| POSITION          | NUMBER       | Original position of the column or attribute in the definition of the object                     |

## USER\_DEPENDENCIES

USER\_DEPENDENCIES describes dependencies between objects accessible to the current user

**Table 9-113** Column information

| Column name            | Data type    | Description                                                                                               |
|------------------------|--------------|-----------------------------------------------------------------------------------------------------------|
| SCHEMA_NAME            | VARCHAR(128) | Schema Name of object                                                                                     |
| NAME                   | VARCHAR(128) | Name of object                                                                                            |
| TYPE                   | VARCHAR(32)  | Type of object: FUNCTION, PROCEDURE, VIEW, PACKAGE, PACKAGE BODY, TRIGGER                                 |
| REFERENCED_OWNER       | VARCHAR(128) | Owner of the referenced object                                                                            |
| REFERENCED_SCHEMA_NAME | VARCHAR(128) | Schema Name of the referenced object                                                                      |
| REFERENCED_TYPE        | VARCHAR(32)  | Type of the referenced object: FUNCTION, PROCEDURE, TABLE, VIEW, SEQUENCE, PACKAGE, PACKAGE BODY, TRIGGER |
| REFERENCED_LINK_NAME   | VARCHAR(128) | Name of the link to the parent object                                                                     |
| REFERENCED_NAME        | VARCHAR(128) | Name of the referenced object                                                                             |
| DEPENDENCY_TYPE        | VARCHAR(32)  | Indicates whether the dependency is a REF dependency (REF) or not (HARD)                                  |

## USER\_EXTENTS

USER\_EXTENTS describes the extents comprising the segments owned by the current user's objects.

**Table 9-114** Column information

| Column name     | Data type    | Description                                                                                                                |
|-----------------|--------------|----------------------------------------------------------------------------------------------------------------------------|
| SEGMENT_SCHEMA  | VARCHAR(128) | Schema of the segment associated with the extent                                                                           |
| SEGMENT_NAME    | VARCHAR(128) | Name of the segment associated with the extent                                                                             |
| PARTITION_NAME  | VARCHAR(128) | <ul style="list-style-type: none"> <li>reserved</li> </ul> Object Partition Name (Set to NULL for non-partitioned objects) |
| SEGMENT_TYPE    | VARCHAR(32)  | Type of the segment: TABLE, INDEX                                                                                          |
| TABLESPACE_NAME | VARCHAR(128) | Name of the tablespace containing the extent                                                                               |
| EXTENT_ID       | NUMBER       | <ul style="list-style-type: none"> <li>reserved</li> </ul> Extent number in the segment                                    |
| BYTES           | NUMBER       | Size of the extent in bytes                                                                                                |
| BLOCKS          | NUMBER       | Size of the extent in Oracle blocks                                                                                        |

## USER\_GLOBAL\_SECONDARY\_INDEXES

USER\_GLOBAL\_SECONDARY\_INDEXES describes the global secondary indexes on the tables owned by the current user.



It is available only on a cluster.

**Table 9-115** Column information

| Column name     | Data type    | Description                                                                                               |
|-----------------|--------------|-----------------------------------------------------------------------------------------------------------|
| TABLE_SCHEMA    | VARCHAR(128) | Schema of the global secondary indexed object                                                             |
| TABLE_NAME      | VARCHAR(128) | Name of the global secondary indexed object                                                               |
| TABLESPACE_NAME | VARCHAR(128) | Name of the tablespace containing the global secondary index                                              |
| INI_TRANS       | NUMBER       | Initial number of transactions                                                                            |
| MAX_TRANS       | NUMBER       | Maximum number of transactions                                                                            |
| INITIAL_EXTENT  | NUMBER       | Size of the initial extent                                                                                |
| NEXT_EXTENT     | NUMBER       | Size of secondary extents                                                                                 |
| MIN_EXTENTS     | NUMBER       | Minimum number of extents allowed in the segment                                                          |
| MAX_EXTENTS     | NUMBER       | Maximum number of extents allowed in the segment                                                          |
| PCT_FREE        | NUMBER       | Minimum percentage of free space in a block                                                               |
| LOGGING         | VARCHAR(3)   | Indicates whether or not changes to the global secondary index are logged: (YES) or (NO)                  |
| BLOCKS          | NUMBER       | Number of used blocks in the global secondary index                                                       |
| EMPTY_BLOCKS    | NUMBER       | Number of empty blocks in the global secondary index                                                      |
| DROPPED         | VARCHAR(3)   | Indicates whether the global secondary index has been dropped and is in the recycle bin (YES) or not (NO) |

## USER\_GSI\_PLACE

USER\_GSI\_PLACE describes node placement of all global secondary indexes on the tables owned by the current user in the cluster system.



It is available only on a cluster.

**Table 9-116** Column information

| Column name    | Data type    | Description                                                                                               |
|----------------|--------------|-----------------------------------------------------------------------------------------------------------|
| TABLE_SCHEMA   | VARCHAR(128) | Schema of the global secondary indexed object                                                             |
| TABLE_NAME     | VARCHAR(128) | Name of the global secondary indexed object                                                               |
| GROUP_ID       | NUMBER       | Group identifier of the node where the global secondary index placed                                      |
| GROUP_NAME     | VARCHAR(128) | Group name of the node where the global secondary index placed                                            |
| MEMBER_ID      | NUMBER       | Member identifier of the node where the global secondary index placed                                     |
| MEMBER_NAME    | VARCHAR(128) | Member name of the node where the global secondary index placed                                           |
| MEMBER_OFFLINE | BOOLEAN      | data of the cluster member is offline or not                                                              |
| DROPPED        | VARCHAR(3)   | Indicates whether the global secondary index has been dropped and is in the recycle bin (YES) or not (NO) |
| BLOCKS         | NUMBER       | Number of used blocks of the node where the global secondary index placed                                 |

## USER\_INDEXES

USER\_INDEXES describes indexes owned by the current user.

**Table 9-117** Column information

| Column name     | Data type    | Description                                                                                                                                                      |
|-----------------|--------------|------------------------------------------------------------------------------------------------------------------------------------------------------------------|
| INDEX_SCHEMA    | VARCHAR(128) | Schema of the index                                                                                                                                              |
| INDEX_NAME      | VARCHAR(128) | Name of the index                                                                                                                                                |
| INDEX_TYPE      | VARCHAR(32)  | Type of the index: the value in ( NORMAL, NORMAL/REV, BITMAP, FUNCTION-BASED NORMAL, FUNCTION-BASED NORMAL/REV, FUNCTION-BASED BITMAP, IOT - TOP, DOMAIN )       |
| TABLE_OWNER     | VARCHAR(128) | Owner of the indexed object                                                                                                                                      |
| TABLE_SCHEMA    | VARCHAR(128) | Schema of the indexed object                                                                                                                                     |
| TABLE_NAME      | VARCHAR(128) | Name of the indexed object                                                                                                                                       |
| TABLE_TYPE      | VARCHAR(32)  | Type of the indexed object: the value in ( NEXT OBJECT, INDEX, TABLE, VIEW, SYNONYM, SEQUENCE )                                                                  |
| UNIQUENESS      | VARCHAR(32)  | Indicates whether the index is unique (UNIQUE) or nonunique (NONUNIQUE)                                                                                          |
| COMPRESSION     | VARCHAR(32)  | <ul style="list-style-type: none"> <li>reserved</li> </ul> Indicates whether index compression is enabled (ENABLED) or not (DISABLED)                            |
| PREFIX_LENGTH   | NUMBER       | <ul style="list-style-type: none"> <li>reserved</li> </ul> Number of columns in the prefix of the compression key                                                |
| TABLESPACE_NAME | VARCHAR(128) | Name of the tablespace containing the index                                                                                                                      |
| INI_TRANS       | NUMBER       | Initial number of transactions                                                                                                                                   |
| MAX_TRANS       | NUMBER       | Maximum number of transactions                                                                                                                                   |
| INITIAL_EXTENT  | NUMBER       | Size of the initial extent                                                                                                                                       |
| NEXT_EXTENT     | NUMBER       | Size of secondary extents                                                                                                                                        |
| MIN_EXTENTS     | NUMBER       | Minimum number of extents allowed in the segment                                                                                                                 |
| MAX_EXTENTS     | NUMBER       | Maximum number of extents allowed in the segment                                                                                                                 |
| PCT_INCREASE    | NUMBER       | <ul style="list-style-type: none"> <li>reserved</li> </ul> Percentage increase in extent size                                                                    |
| PCT_THRESHOLD   | NUMBER       | <ul style="list-style-type: none"> <li>reserved</li> </ul> Threshold percentage of block space allowed per index entry                                           |
| INCLUDE_COLUMN  | NUMBER       | <ul style="list-style-type: none"> <li>reserved</li> </ul> Column ID of the last column to be included in index-organized table primary key (non-overflow) index |
| FREELISTS       | NUMBER       | <ul style="list-style-type: none"> <li>reserved</li> </ul> Number of process freelists allocated to this segment                                                 |
| FREELIST_GROUPS | NUMBER       | <ul style="list-style-type: none"> <li>reserved</li> </ul> Number of freelist groups allocated to this segment                                                   |

| Column name             | Data type                         | Description                                                                                                                                                                               |
|-------------------------|-----------------------------------|-------------------------------------------------------------------------------------------------------------------------------------------------------------------------------------------|
| PCT_FREE                | NUMBER                            | Minimum percentage of free space in a block                                                                                                                                               |
| LOGGING                 | VARCHAR(3)                        | Indicates whether or not changes to the index are logged: (YES) or (NO)                                                                                                                   |
| BLOCKS                  | NUMBER                            | Number of used blocks in the index                                                                                                                                                        |
| EMPTY_BLOCKS            | NUMBER                            | Number of empty blocks in the index                                                                                                                                                       |
| BLEVEL                  | NUMBER                            | <ul style="list-style-type: none"> <li>reserved</li> </ul> B-Tree level (depth of the index from its root block to its leaf blocks)                                                       |
| LEAF_BLOCKS             | NUMBER                            | <ul style="list-style-type: none"> <li>reserved</li> </ul> Number of leaf blocks in the index                                                                                             |
| DISTINCT_KEYS           | NUMBER                            | Number of distinct indexed values.                                                                                                                                                        |
| AVG_LEAF_BLOCKS_PER_KEY | NUMBER                            | <ul style="list-style-type: none"> <li>reserved</li> </ul> Average number of leaf blocks in which each distinct value in the index appears, rounded to the nearest integer                |
| AVG_DATA_BLOCKS_PER_KEY | NUMBER                            | <ul style="list-style-type: none"> <li>reserved</li> </ul> Average number of data blocks in the table that are pointed to by a distinct value in the index rounded to the nearest integer |
| CLUSTERING_FACTOR       | NUMBER                            | <ul style="list-style-type: none"> <li>reserved</li> </ul> Indicates the amount of order of the rows in the table based on the values of the index                                        |
| STATUS                  | VARCHAR(32)                       | <ul style="list-style-type: none"> <li>reserved</li> </ul> Indicates whether a nonpartitioned index is VALID or UNUSABLE                                                                  |
| NUM_ROWS                | NUMBER                            | <ul style="list-style-type: none"> <li>reserved</li> </ul> Number of rows in the index                                                                                                    |
| SAMPLE_SIZE             | NUMBER                            | Size of the sample used to analyze the index                                                                                                                                              |
| LAST_ANALYZED           | TIMESTAMP(6)<br>WITHOUT TIME ZONE | Date on which this index was most recently analyzed                                                                                                                                       |
| DEGREE                  | VARCHAR(32)                       | <ul style="list-style-type: none"> <li>reserved</li> </ul> Number of threads per instance for scanning the index, or DEFAULT                                                              |
| INSTANCES               | VARCHAR(32)                       | <ul style="list-style-type: none"> <li>reserved</li> </ul> Number of instances across which the indexes to be scanned, or DEFAULT                                                         |
| PARTITIONED             | VARCHAR(3)                        | <ul style="list-style-type: none"> <li>reserved</li> </ul> Indicates whether the index is partitioned (YES) or not (NO)                                                                   |
| TEMPORARY               | VARCHAR(1)                        | Indicates whether the index is on a temporary table (Y) or not (N)                                                                                                                        |
| GENERATED               | VARCHAR(1)                        | Indicates whether the name of the index is system-generated (Y) or not (N)                                                                                                                |
| SECONDARY               | VARCHAR(1)                        | <ul style="list-style-type: none"> <li>reserved</li> </ul> Indicates whether the index is a secondary object created by the method of the Data Cartridge (Y) or not (N)                   |
| BUFFER_POOL             | VARCHAR(32)                       | <ul style="list-style-type: none"> <li>reserved</li> </ul> Buffer pool to be used for index blocks                                                                                        |
| FLASH_CACHE             | VARCHAR(32)                       | <ul style="list-style-type: none"> <li>reserved</li> </ul> Database Smart Flash Cache hint to be used for index blocks                                                                    |

| Column name             | Data type     | Description                                                                                                                                                                                                                                                     |
|-------------------------|---------------|-----------------------------------------------------------------------------------------------------------------------------------------------------------------------------------------------------------------------------------------------------------------|
| CELL_FLASH_CACHE        | VARCHAR(32)   | <ul style="list-style-type: none"> <li>reserved</li> </ul> Cell flash cache hint to be used for index blocks                                                                                                                                                    |
| USER_STATS              | VARCHAR(3)    | <ul style="list-style-type: none"> <li>reserved</li> </ul> Indicates whether statistics were entered directly by the user (YES) or not (NO)                                                                                                                     |
| DURATION                | VARCHAR(32)   | Indicates the duration of a temporary table, the value is in ( TRANSACTION, SESSION )                                                                                                                                                                           |
| PCT_DIRECT_ACCESS       | NUMBER        | <ul style="list-style-type: none"> <li>reserved</li> </ul> For a secondary index on an index-organized table, the percentage of rows with VALID guess                                                                                                           |
| ITYP_OWNER              | VARCHAR(128)  | <ul style="list-style-type: none"> <li>reserved</li> </ul> For a domain index, the owner of the indextype                                                                                                                                                       |
| ITYP_NAME               | VARCHAR(128)  | <ul style="list-style-type: none"> <li>reserved</li> </ul> For a domain index, the name of the indextype                                                                                                                                                        |
| PARAMETERS              | VARCHAR(1024) | <ul style="list-style-type: none"> <li>reserved</li> </ul> For a domain index, the parameter string                                                                                                                                                             |
| GLOBAL_STATS            | VARCHAR(3)    | <ul style="list-style-type: none"> <li>reserved</li> </ul> For partitioned indexes, indicates whether statistics were collected by analyzing the index as a whole (YES) or were estimated from statistics on underlying index partitions and subpartitions (NO) |
| DOMIDX_STATUSES         | VARCHAR(32)   | <ul style="list-style-type: none"> <li>reserved</li> </ul> Status of a domain index                                                                                                                                                                             |
| DOMIDX_OPSTATUS         | VARCHAR(32)   | <ul style="list-style-type: none"> <li>reserved</li> </ul> Status of the operation on a domain index                                                                                                                                                            |
| FUNCIDX_STATUSES        | VARCHAR(32)   | <ul style="list-style-type: none"> <li>reserved</li> </ul> Status of a function-based index                                                                                                                                                                     |
| JOIN_INDEX              | VARCHAR(3)    | <ul style="list-style-type: none"> <li>reserved</li> </ul> Indicates whether the index is a join index (YES) or not (NO)                                                                                                                                        |
| IOT_REDUNDANT_PKEY_ELIM | VARCHAR(3)    | <ul style="list-style-type: none"> <li>reserved</li> </ul> Indicates whether redundant primary key columns are eliminated from secondary indexes on index-organized tables (YES) or not (NO)                                                                    |
| DROPPED                 | VARCHAR(3)    | Indicates whether the index has been dropped and is in the recycle bin (YES) or not (NO)                                                                                                                                                                        |
| VISIBILITY              | VARCHAR(3)    | <ul style="list-style-type: none"> <li>reserved</li> </ul> Indicates whether the index is VISIBLE or INVISIBLE to the optimizer                                                                                                                                 |
| DOMIDX_MANAGEMENT       | VARCHAR(32)   | <ul style="list-style-type: none"> <li>reserved</li> </ul> If this is a domain index, indicates whether the domain index is system-managed (SYSTEM_MANAGED) or user-managed (USER_MANAGED)                                                                      |
| SEGMENT_CREATED         | VARCHAR(3)    | Indicates whether the index segment has been created (YES) or not (NO)                                                                                                                                                                                          |
| COMMENTS                | VARCHAR(1024) | Comments of the index                                                                                                                                                                                                                                           |



| Column name  | Data type | Description                         |
|--------------|-----------|-------------------------------------|
| EMPTY_BLOCKS | NUMBER    | Number of empty blocks in the index |

## USER\_IND\_COLUMNS

USER\_IND\_COLUMNS describes the columns of the indexes owned by the current user and columns of indexes on tables owned by the current user.

**Table 9-118** Column information

| Column name     | Data type    | Description                                                                                                                  |
|-----------------|--------------|------------------------------------------------------------------------------------------------------------------------------|
| INDEX_SCHEMA    | VARCHAR(128) | Schema of the index                                                                                                          |
| INDEX_NAME      | VARCHAR(128) | Name of the index                                                                                                            |
| TABLE_SCHEMA    | VARCHAR(128) | Schema of the table or cluster                                                                                               |
| TABLE_NAME      | VARCHAR(128) | Name of the table or cluster                                                                                                 |
| COLUMN_NAME     | VARCHAR(128) | Column name or attribute of the object type column                                                                           |
| COLUMN_POSITION | NUMBER       | Position of the column or attribute within the index                                                                         |
| COLUMN_LENGTH   | NUMBER       | Indexed length of the column                                                                                                 |
| CHAR_LENGTH     | NUMBER       | <ul style="list-style-type: none"> <li>reserved</li> </ul> Maximum codepoint length of the column                            |
| DESCEND         | VARCHAR(32)  | Indicates whether the column is sorted in descending order (DESC) or ascending order (ASC)                                   |
| NULL_ORDER      | VARCHAR(32)  | Indicates whether the null value of the column is sorted in nulls first order (NULLS FIRST) or nulls last order (NULLS LAST) |

## USER\_IND\_PLACE

USER\_IND\_PLACE describes node placement of the indexes owned by the current user in the cluster system.



It is available only on a cluster.

**Table 9-119** Column information

| Column name    | Data type                          | Description                                                                              |
|----------------|------------------------------------|------------------------------------------------------------------------------------------|
| INDEX_SCHEMA   | VARCHAR(128)                       | Schema of the index                                                                      |
| INDEX_NAME     | VARCHAR(128)                       | Name of the index                                                                        |
| TABLE_OWNER    | VARCHAR(128)                       | Owner of the indexed object                                                              |
| TABLE_SCHEMA   | VARCHAR(128)                       | Schema of the indexed object                                                             |
| TABLE_NAME     | VARCHAR(128)                       | Name of the indexed object                                                               |
| GROUP_ID       | NUMBER                             | Group identifier of the node where the index placed                                      |
| GROUP_NAME     | VARCHAR(128)                       | Group name of the node where the index placed                                            |
| MEMBER_ID      | NUMBER                             | Member identifier of the node where the index placed                                     |
| MEMBER_NAME    | VARCHAR(128)                       | Member name of the node where the index placed                                           |
| MEMBER_OFFLINE | BOOLEAN                            | data of the cluster member is offline or not                                             |
| DROPPED        | VARCHAR(3)                         | Indicates whether the index has been dropped and is in the recycle bin (YES) or not (NO) |
| DISTINCT_KEYS  | NUMBER                             | (deprecated)                                                                             |
| SAMPLE_SIZE    | NUMBER                             | (deprecated)                                                                             |
| BLOCKS         | NUMBER                             | Number of used blocks of the node where the index placed                                 |
| LAST_ANALYZED  | TIMESTAMP(2) WITH<br>OUT TIME ZONE | (deprecated)                                                                             |

## USER\_OBJECTS

USER\_OBJECTS describes all objects owned by the current user.

**Table 9-120** Column information

| Column name    | Data type                      | Description                                                                                                                                                                                |
|----------------|--------------------------------|--------------------------------------------------------------------------------------------------------------------------------------------------------------------------------------------|
| SCHEMA_NAME    | VARCHAR(128)                   | Schema of the object                                                                                                                                                                       |
| OBJECT_NAME    | VARCHAR(128)                   | Name of the object                                                                                                                                                                         |
| SUBOBJECT_NAME | VARCHAR(128)                   | Name of the subobject (for example, partition)                                                                                                                                             |
| OBJECT_ID      | NUMBER                         | Dictionary object number of the object                                                                                                                                                     |
| DATA_OBJECT_ID | NUMBER                         | Dictionary object number of the segment that contains the object                                                                                                                           |
| OBJECT_TYPE    | VARCHAR(32)                    | Type of the object (such as TABLE, INDEX)                                                                                                                                                  |
| CREATED        | TIMESTAMP(2) WITHOUT TIME ZONE | Timestamp for the creation of the object                                                                                                                                                   |
| LAST_DDL_TIME  | TIMESTAMP(2) WITHOUT TIME ZONE | Timestamp for the last modification of the object resulting from a DDL statement                                                                                                           |
| TIMESTAMP      | VARCHAR(32)                    | Timestamp for the specification of the object (character data)                                                                                                                             |
| STATUS         | VARCHAR(32)                    | <ul style="list-style-type: none"> <li>reserved</li> </ul> Status of the object: the value in ( VALID, INVALID, N/A )                                                                      |
| TEMPORARY      | VARCHAR(1)                     | Indicates whether the object is temporary (the current session can see only data that it placed in this object itself) (Y) or not (N)                                                      |
| GENERATED      | VARCHAR(1)                     | Indicates whether the name of this object was system-generated (Y) or not (N)                                                                                                              |
| SECONDARY      | VARCHAR(1)                     | <ul style="list-style-type: none"> <li>reserved</li> </ul> Indicates whether this is a secondary object created by the ODCIIndex Create method of the Oracle Data Cartridge (Y) or not (N) |
| NAMESPACE      | NUMBER                         | Namespace for the object                                                                                                                                                                   |
| EDITION_NAME   | VARCHAR(128)                   | <ul style="list-style-type: none"> <li>reserved</li> </ul> Name of the edition in which the object is actual                                                                               |
| DROPPED        | VARCHAR(3)                     | Indicates whether the object has been dropped and is in the recycle bin (YES) or not (NO)                                                                                                  |

## USER\_PACKAGE\_PRIVS

USER\_PACKAGE\_PRIVS describes the package grants for which the current user is the package owner, grantor, or grantee.

**Table 9-121** Column information

| Column name      | Data type    | Description                                                                         |
|------------------|--------------|-------------------------------------------------------------------------------------|
| GRANTOR          | VARCHAR(128) | Name of the user who performed the grant                                            |
| GRANTEE          | VARCHAR(128) | Name of the user or role to whom access was granted                                 |
| PROCEDURE_OWNER  | VARCHAR(128) | Owner of the package                                                                |
| PROCEDURE_SCHEMA | VARCHAR(128) | Schema of the package                                                               |
| PROCEDURE_NAME   | VARCHAR(128) | Name of the package                                                                 |
| PRIVILEGE        | VARCHAR(32)  | Privilege on the package                                                            |
| GRANTABLE        | VARCHAR(3)   | Indicates whether the privilege was granted with the GRANT OPTION (YES) or not (NO) |

## USER\_PACKAGE\_PRIVS\_MADE

USER\_PACKAGE\_PRIVS\_MADE describes the package grants for which the current user is the package owner.

**Table 9-122** Column information

| Column name      | Data type    | Description                                                                         |
|------------------|--------------|-------------------------------------------------------------------------------------|
| GRANTOR          | VARCHAR(128) | Name of the user who performed the grant                                            |
| GRANTEE          | VARCHAR(128) | Name of the user or role to whom access was granted                                 |
| PROCEDURE_OWNER  | VARCHAR(128) | Owner of the package                                                                |
| PROCEDURE_SCHEMA | VARCHAR(128) | Schema of the package                                                               |
| PROCEDURE_NAME   | VARCHAR(128) | Name of the package                                                                 |
| PRIVILEGE        | VARCHAR(32)  | Privilege on the package                                                            |
| GRANTABLE        | VARCHAR(3)   | Indicates whether the privilege was granted with the GRANT OPTION (YES) or not (NO) |

## USER\_PACKAGE\_PRIVS\_REC'D

USER\_PACKAGE\_PRIVS\_REC'D describes the package grants for which the current user is the grantee.

**Table 9-123** Column information

| Column name      | Data type    | Description                                                                         |
|------------------|--------------|-------------------------------------------------------------------------------------|
| GRANTOR          | VARCHAR(128) | Name of the user who performed the grant                                            |
| GRANTEE          | VARCHAR(128) | Name of the user or role to whom access was granted                                 |
| PROCEDURE_OWNER  | VARCHAR(128) | Owner of the package                                                                |
| PROCEDURE_SCHEMA | VARCHAR(128) | Schema of the package                                                               |
| PROCEDURE_NAME   | VARCHAR(128) | Name of the package                                                                 |
| PRIVILEGE        | VARCHAR(32)  | Privilege on the package                                                            |
| GRANTABLE        | VARCHAR(3)   | Indicates whether the privilege was granted with the GRANT OPTION (YES) or not (NO) |

## USER\_PROCEDURES

USER\_PROCEDURES lists of procedures owned by the current user.

**Table 9-124** Column information

| Column name    | Data type    | Description                                                                                             |
|----------------|--------------|---------------------------------------------------------------------------------------------------------|
| SCHEMA_NAME    | VARCHAR(128) | Schema Name of function, procedures or package                                                          |
| OBJECT_NAME    | VARCHAR(128) | Name of function, procedures or package                                                                 |
| PROCEDURE_NAME | VARCHAR(128) | Name when a procedure in package                                                                        |
| OBJECT_ID      | NUMBER       | ID of a function, procedures or package                                                                 |
| SUBPROGRAM_ID  | NUMBER       | ID of procedures in package                                                                             |
| OVERLOAD       | VARCHAR(32)  | ID of overloading procedure in package                                                                  |
| OBJECT_TYPE    | VARCHAR(32)  | Type of function, procedures or package                                                                 |
| AGGREGATE      | VARCHAR(3)   | Indicate whether the procedure is an aggregate function (YES) or not (NO)                               |
| PIPELINED      | VARCHAR(3)   | Indicate whether the procedure is a pipelined table function (YES) or not (NO)                          |
| IMPLTYPEOWNER  | VARCHAR(128) | Name of the owner of the implementation type, if any                                                    |
| IMPLTYPE_NAME  | VARCHAR(128) | Name of the implementation type, if any                                                                 |
| PARALLEL       | VARCHAR(3)   | Indicates whether the procedure or function is parallel-enabled (YES) or not (NO)                       |
| INTERFACE      | VARCHAR(3)   | YES, if the procedure/function is a table function implemented using the SQLCLI interface; otherwise NO |
| DETERMINISTIC  | VARCHAR(3)   | YES, if the procedure/function is declared to be deterministic; otherwise NO                            |
| AUTHID         | VARCHAR(32)  | Indicates whether the procedure/function is declared to execute as DEFINER or CURRENT_USER (invoker)    |



## USER\_PROC\_PRIVS

USER\_PROC\_PRIVS describes the procedure grants for which the current user is the procedure owner, grantor, or grantee.

**Table 9-125** Column information

| Column name      | Data type    | Description                                                                         |
|------------------|--------------|-------------------------------------------------------------------------------------|
| GRANTOR          | VARCHAR(128) | Name of the user who performed the grant                                            |
| GRANTEE          | VARCHAR(128) | Name of the user or role to whom access was granted                                 |
| PROCEDURE_OWNER  | VARCHAR(128) | Owner of the procedure and function                                                 |
| PROCEDURE_SCHEMA | VARCHAR(128) | Schema of the procedure and function                                                |
| PROCEDURE_NAME   | VARCHAR(128) | Name of the procedure and function                                                  |
| PRIVILEGE        | VARCHAR(32)  | Privilege on the procedure and function                                             |
| GRANTABLE        | VARCHAR(3)   | Indicates whether the privilege was granted with the GRANT OPTION (YES) or not (NO) |

## USER\_PROC\_PRIVS\_MADE

USER\_PROC\_PRIVS\_MADE describes the procedure grants for which the current user is the procedure owner or grantor.

**Table 9-126** Column information

| Column name      | Data type    | Description                                                                         |
|------------------|--------------|-------------------------------------------------------------------------------------|
| GRANTOR          | VARCHAR(128) | Name of the user who performed the grant                                            |
| GRANTEE          | VARCHAR(128) | Name of the user or role to whom access was granted                                 |
| PROCEDURE_OWNER  | VARCHAR(128) | Owner of the procedure and function                                                 |
| PROCEDURE_SCHEMA | VARCHAR(128) | Schema of the procedure and function                                                |
| PROCEDURE_NAME   | VARCHAR(128) | Name of the procedure and function                                                  |
| PRIVILEGE        | VARCHAR(32)  | Privilege on the procedure and function                                             |
| GRANTABLE        | VARCHAR(3)   | Indicates whether the privilege was granted with the GRANT OPTION (YES) or not (NO) |

## USER\_PROC\_PRIVS\_RECD

USER\_PROC\_PRIVS\_RECD describes the procedure grants, for which the current user is the grantee, or for which an enabled role or PUBLIC is the grantee.

**Table 9-127** Column information

| Column name      | Data type    | Description                                                                         |
|------------------|--------------|-------------------------------------------------------------------------------------|
| GRANTOR          | VARCHAR(128) | Name of the user who performed the grant                                            |
| GRANTEE          | VARCHAR(128) | Name of the user or role to whom access was granted                                 |
| PROCEDURE_OWNER  | VARCHAR(128) | Owner of the procedure and function                                                 |
| PROCEDURE_SCHEMA | VARCHAR(128) | Schema of the procedure and function                                                |
| PROCEDURE_NAME   | VARCHAR(128) | Name of the procedure and function                                                  |
| PRIVILEGE        | VARCHAR(32)  | Privilege on the procedure and function                                             |
| GRANTABLE        | VARCHAR(3)   | Indicates whether the privilege was granted with the GRANT OPTION (YES) or not (NO) |

## USER\_RECYCLEBIN

USER\_RECYCLEBIN describes recycle bins owned by the current user.

**Table 9-128** Column information

| Column name     | Data type                          | Description                                                                             |
|-----------------|------------------------------------|-----------------------------------------------------------------------------------------|
| SCHEMA_NAME     | VARCHAR(128)                       | Schema name of the object                                                               |
| OBJECT_NAME     | VARCHAR(128)                       | Name of the object                                                                      |
| ORIGINAL_NAME   | VARCHAR(128)                       | Original name of the object                                                             |
| OPERATION       | VARCHAR(4)                         | Operation carried out on the object                                                     |
| OBJECT_TYPE     | VARCHAR(32)                        | Type of the object                                                                      |
| TABLESPACE_NAME | VARCHAR(128)                       | Name of the tablespace containing the object                                            |
| CREATED_TIME    | TIMESTAMP(2) WITH<br>OUT TIME ZONE | Created time of the object                                                              |
| DROPPED_TIME    | TIMESTAMP(2) WITH<br>OUT TIME ZONE | Dropped time of the object                                                              |
| DROP_SCN        | VARCHAR(128)                       | System change number (SCN) of the transaction which moved the object to the recycle bin |
| DROP_GCN        | NUMBER                             | Global change number (GCN) of the transaction which moved the object to the recycle bin |
| DROP_DCN        | NUMBER                             | Domain change number (DCN) of the transaction which moved the object to the recycle bin |
| DROP_LCN        | NUMBER                             | Local change number (LCN) of the transaction which moved the object to the recycle bin  |
| CAN_UNDROP      | VARCHAR(3)                         | Indicates whether the object can be undropped (YES) or not (NO)                         |
| CAN_PURGE       | VARCHAR(3)                         | Indicates whether the object can be purged (YES) or not (NO)                            |
| BASE_OBJECT     | NUMBER                             | Object number of the base object                                                        |
| PURGE_OBJECT    | NUMBER                             | Object number for the object which gets purged                                          |

## USER\_SCHEMAS

Identify the schemata in a catalog that are owned by current user.

**Table 9-129** Column information

| Column name   | Data type                      | Description                      |
|---------------|--------------------------------|----------------------------------|
| SCHEMA_OWNER  | VARCHAR(128)                   | Owner of the schema              |
| SCHEMA_NAME   | VARCHAR(128)                   | Name of the schema               |
| CREATED_TIME  | TIMESTAMP(2) WITHOUT TIME ZONE | Created time of the schema       |
| MODIFIED_TIME | TIMESTAMP(2) WITHOUT TIME ZONE | Last modified time of the schema |
| COMMENTS      | VARCHAR(1024)                  | Comments of the schema           |

## USER\_SCHEMA\_PATH

USER\_SCHEMA\_PATH describes the schema search order of the current user, for naming resolution of unqualified SQL schema objects.

**Table 9-130** Column information

| Column name  | Data type    | Description                     |
|--------------|--------------|---------------------------------|
| AUTH_NAME    | VARCHAR(128) | Name of the user                |
| SCHEMA_NAME  | VARCHAR(128) | Name of the schema              |
| SEARCH_ORDER | NUMBER       | Schema search order of the user |

## USER\_SCHEMA\_PRIVS

USER\_SCHEMA\_PRIVS describes the schema grants, for which the current user is the schema owner, grantor, or grantee.

**Table 9-131** Column information

| Column name | Data type    | Description                                                                         |
|-------------|--------------|-------------------------------------------------------------------------------------|
| GRANTOR     | VARCHAR(128) | Name of the user who performed the grant                                            |
| GRANTEE     | VARCHAR(128) | Name of the user or role to whom access was granted                                 |
| OWNER       | VARCHAR(128) | Owner of the schema                                                                 |
| SCHEMA_NAME | VARCHAR(128) | Name of the schema                                                                  |
| PRIVILEGE   | VARCHAR(32)  | Privilege on the schema                                                             |
| GRANTABLE   | VARCHAR(3)   | Indicates whether the privilege was granted with the GRANT OPTION (YES) or not (NO) |

## USER\_SCHEMA\_PRIVS\_MADE

USER\_SCHEMA\_PRIVS\_MADE describes the schema grants for which the current user is the schema owner.

**Table 9-132** Column information

| Column name | Data type    | Description                                                                         |
|-------------|--------------|-------------------------------------------------------------------------------------|
| GRANTOR     | VARCHAR(128) | Name of the user who performed the grant                                            |
| GRANTEE     | VARCHAR(128) | Name of the user or role to whom access was granted                                 |
| OWNER       | VARCHAR(128) | Owner of the schema                                                                 |
| SCHEMA_NAME | VARCHAR(128) | Name of the schema                                                                  |
| PRIVILEGE   | VARCHAR(32)  | Privilege on the schema                                                             |
| GRANTABLE   | VARCHAR(3)   | Indicates whether the privilege was granted with the GRANT OPTION (YES) or not (NO) |



## USER\_SCHEMA\_PRIVS\_REC'D

USER\_SCHEMA\_PRIVS\_REC'D describes the schema grants for which the current user is the grantee.

**Table 9-133** Column information

| Column name | Data type    | Description                                                                         |
|-------------|--------------|-------------------------------------------------------------------------------------|
| GRANTOR     | VARCHAR(128) | Name of the user who performed the grant                                            |
| GRANTEE     | VARCHAR(128) | Name of the user or role to whom access was granted                                 |
| OWNER       | VARCHAR(128) | Owner of the schema                                                                 |
| SCHEMA_NAME | VARCHAR(128) | Name of the schema                                                                  |
| PRIVILEGE   | VARCHAR(32)  | Privilege on the schema                                                             |
| GRANTABLE   | VARCHAR(3)   | Indicates whether the privilege was granted with the GRANT OPTION (YES) or not (NO) |

## USER\_SEQUENCES

USER\_SEQUENCES describes all sequences owned by the current user.

**Table 9-134** Column information

| Column name     | Data type     | Description                                                                                                                                           |
|-----------------|---------------|-------------------------------------------------------------------------------------------------------------------------------------------------------|
| SEQUENCE_OWNER  | VARCHAR(128)  | Owner of the sequence                                                                                                                                 |
| SEQUENCE_SCHEMA | VARCHAR(128)  | Schema of the sequence                                                                                                                                |
| SEQUENCE_NAME   | VARCHAR(128)  | Sequence name                                                                                                                                         |
| MIN_VALUE       | NUMBER        | Minimum value of the sequence                                                                                                                         |
| MAX_VALUE       | NUMBER        | Maximum value of the sequence                                                                                                                         |
| INCREMENT_BY    | NUMBER        | Value by which sequence is incremented                                                                                                                |
| CYCLE_FLAG      | VARCHAR(1)    | Indicates whether the sequence wraps around on reaching the limit (Y) or not (N)                                                                      |
| ORDER_FLAG      | VARCHAR(1)    | <ul style="list-style-type: none"> <li>reserved</li> </ul> Indicates whether sequence numbers are generated in order (Y) or not (N)                   |
| CACHE_SIZE      | NUMBER        | Number of sequence numbers to cache                                                                                                                   |
| LAST_NUMBER     | NUMBER        | Last sequence number written to database. If a sequence uses caching, the number written to database is the last number placed in the sequence cache. |
| COMMENTS        | VARCHAR(1024) | Comments of the sequence                                                                                                                              |

## USER\_SEQ\_PRIVS

USER\_SEQ\_PRIVS describes the sequence grants for which the current user is the sequence owner, grantor, or grantee.

**Table 9-135** Column information

| Column name     | Data type    | Description                                                                         |
|-----------------|--------------|-------------------------------------------------------------------------------------|
| GRANTOR         | VARCHAR(128) | Name of the user who performed the grant                                            |
| GRANTEE         | VARCHAR(128) | Name of the user or role to whom access was granted                                 |
| SEQUENCE_OWNER  | VARCHAR(128) | Owner of the sequence                                                               |
| SEQUENCE_SCHEMA | VARCHAR(128) | Schema of the sequence                                                              |
| SEQUENCE_NAME   | VARCHAR(128) | Name of the sequence                                                                |
| PRIVILEGE       | VARCHAR(32)  | Privilege on the sequence                                                           |
| GRANTABLE       | VARCHAR(3)   | Indicates whether the privilege was granted with the GRANT OPTION (YES) or not (NO) |

## USER\_SEQ\_PRIVS\_MADE

USER\_SEQ\_PRIVS\_MADE describes the sequence grants for which the current user is the sequence owner.

**Table 9-136** Column information

| Column name     | Data type    | Description                                                                         |
|-----------------|--------------|-------------------------------------------------------------------------------------|
| GRANTOR         | VARCHAR(128) | Name of the user who performed the grant                                            |
| GRANTEE         | VARCHAR(128) | Name of the user or role to whom access was granted                                 |
| SEQUENCE_OWNER  | VARCHAR(128) | Owner of the sequence                                                               |
| SEQUENCE_SCHEMA | VARCHAR(128) | Schema of the sequence                                                              |
| SEQUENCE_NAME   | VARCHAR(128) | Name of the sequence                                                                |
| PRIVILEGE       | VARCHAR(32)  | Privilege on the sequence                                                           |
| GRANTABLE       | VARCHAR(3)   | Indicates whether the privilege was granted with the GRANT OPTION (YES) or not (NO) |

## USER\_SEQ\_PRIVS\_REC'D

USER\_SEQ\_PRIVS\_REC'D describes the sequence grants for which the current user is the grantee.

**Table 9-137** Column information

| Column name     | Data type    | Description                                                                         |
|-----------------|--------------|-------------------------------------------------------------------------------------|
| GRANTOR         | VARCHAR(128) | Name of the user who performed the grant                                            |
| GRANTEE         | VARCHAR(128) | Name of the user or role to whom access was granted                                 |
| SEQUENCE_OWNER  | VARCHAR(128) | Owner of the sequence                                                               |
| SEQUENCE_SCHEMA | VARCHAR(128) | Schema of the sequence                                                              |
| SEQUENCE_NAME   | VARCHAR(128) | Name of the sequence                                                                |
| PRIVILEGE       | VARCHAR(32)  | Privilege on the sequence                                                           |
| GRANTABLE       | VARCHAR(3)   | Indicates whether the privilege was granted with the GRANT OPTION (YES) or not (NO) |

## USER\_SHARD\_KEY\_COLUMNS

USER\_SHARD\_KEY\_COLUMNS describes shard key columns of shared tables owned by the current user in the cluster system.



It is available only on a cluster.

**Table 9-138** Column information

| Column name     | Data type    | Description                                 |
|-----------------|--------------|---------------------------------------------|
| TABLE_SCHEMA    | VARCHAR(128) | Schema of the table                         |
| TABLE_NAME      | VARCHAR(128) | Name of the table                           |
| COLUMN_NAME     | VARCHAR(128) | Column name of the shard key                |
| COLUMN_POSITION | NUMBER       | Position of the column within the shard key |

## USER\_SOURCE

USER\_SOURCE describes the text source of the stored objects accessible to the current user.

**Table 9-139** Column information

| Column name   | Data type    | Description                                                         |
|---------------|--------------|---------------------------------------------------------------------|
| SCHEMA_NAME   | VARCHAR(128) | Schema Name of object                                               |
| NAME          | VARCHAR(128) | Name of object                                                      |
| TYPE          | VARCHAR(32)  | Type of object: FUNCTION, PROCEDURE, PACKAGE, PACKAGE BODY, TRIGGER |
| LINE          | NUMBER       | Line number of this line of source                                  |
| TEXT          | LONG VARCHAR | Text source of the stored object                                    |
| ORIGIN_CON_ID | VARCHAR(256) | ID of the container where the data originates                       |

## USER\_SYNONYMS

USER\_SYNONYMS describes all synonyms owned by the current user.

**Table 9-140** Column information

| Column name        | Data type    | Description             |
|--------------------|--------------|-------------------------|
| SYNONYM_OWNER      | VARCHAR(128) | Owner of the synonym    |
| SYNONYM_SCHEMA     | VARCHAR(128) | Schema of the synonym   |
| SYNONYM_NAME       | VARCHAR(128) | Synonym name            |
| OBJECT_SCHEMA_NAME | VARCHAR(128) | Object schema name      |
| OBJECT_NAME        | VARCHAR(128) | Object name             |
| DB_LINK            | VARCHAR(128) | Reserved for future use |



## USER\_SYS\_PRIVS

USER\_SYS\_PRIVS describes system (database, tablespace, schema) privileges granted to the current user or PUBLIC.

**Table 9-141** Column information

| Column name  | Data type    | Description                                                                         |
|--------------|--------------|-------------------------------------------------------------------------------------|
| USERNAME     | VARCHAR(128) | Name of the user, or PUBLIC                                                         |
| PRIVILEGE    | VARCHAR(256) | System(database, tablespace, schema) privilege                                      |
| GRANTABLE    | VARCHAR(3)   | Indicates whether the privilege was granted with the GRANT OPTION (YES) or not (NO) |
| ADMIN_OPTION | VARCHAR(3)   | equal to GRANTABLE column                                                           |

## USER\_TABLES

USER\_TABLES describes the relational tables owned by the current user.

**Table 9-142** Column information

| Column name     | Data type    | Description                                                                                                                                                               |
|-----------------|--------------|---------------------------------------------------------------------------------------------------------------------------------------------------------------------------|
| TABLE_SCHEMA    | VARCHAR(128) | Schema of the table                                                                                                                                                       |
| TABLE_NAME      | VARCHAR(128) | Name of the table                                                                                                                                                         |
| TABLESPACE_NAME | VARCHAR(128) | Name of the tablespace containing the table                                                                                                                               |
| CLUSTER_NAME    | VARCHAR(128) | <ul style="list-style-type: none"> <li>reserved</li> </ul> Name of the cluster                                                                                            |
| IOT_NAME        | VARCHAR(128) | <ul style="list-style-type: none"> <li>reserved</li> </ul> Name of the index-organized table                                                                              |
| STATUS          | VARCHAR(32)  | <ul style="list-style-type: none"> <li>reserved</li> </ul> If a previous DROP TABLE operation failed, indicates whether the table is unusable (UNUSABLE) or valid (VALID) |
| PCT_FREE        | NUMBER       | Minimum percentage of free space in a block                                                                                                                               |
| PCT_USED        | NUMBER       | Minimum percentage of used space in a block                                                                                                                               |
| INI_TRANS       | NUMBER       | Initial number of transactions                                                                                                                                            |
| MAX_TRANS       | NUMBER       | Maximum number of transactions                                                                                                                                            |
| INITIAL_EXTENT  | NUMBER       | Size of the initial extent (in bytes)                                                                                                                                     |
| NEXT_EXTENT     | NUMBER       | Size of secondary extents (in bytes)                                                                                                                                      |
| MIN_EXTENTS     | NUMBER       | Minimum number of extents allowed in the segment                                                                                                                          |
| MAX_EXTENTS     | NUMBER       | Maximum number of extents allowed in the segment                                                                                                                          |
| PCT_INCREASE    | NUMBER       | <ul style="list-style-type: none"> <li>reserved</li> </ul> Percentage increase in extent size                                                                             |
| FREELISTS       | NUMBER       | <ul style="list-style-type: none"> <li>reserved</li> </ul> Number of process freelists allocated to the segment                                                           |
| FREELIST_GROUPS | NUMBER       | <ul style="list-style-type: none"> <li>reserved</li> </ul> Number of freelist groups allocated to the segment                                                             |
| LOGGING         | VARCHAR(3)   | Indicates whether or not changes to the table are logged                                                                                                                  |
| BACKED_UP       | VARCHAR(1)   | <ul style="list-style-type: none"> <li>reserved</li> </ul> Indicates whether the table has been backed up since the last modification (Y) or not (N)                      |
| NUM_ROWS        | NUMBER       | Number of rows in the table                                                                                                                                               |
| BLOCKS          | NUMBER       | Number of used blocks in the table                                                                                                                                        |
| EMPTY_BLOCKS    | NUMBER       | <ul style="list-style-type: none"> <li>reserved</li> </ul> Number of empty (never used) blocks in the table                                                               |
| AVG_SPACE       | NUMBER       | <ul style="list-style-type: none"> <li>reserved</li> </ul> Average available free space in the table                                                                      |
|                 |              | <ul style="list-style-type: none"> <li>reserved</li> </ul>                                                                                                                |

| Column name               | Data type                         | Description                                                                                                                                                   |
|---------------------------|-----------------------------------|---------------------------------------------------------------------------------------------------------------------------------------------------------------|
| CHAIN_CNT                 | NUMBER                            | Number of rows in the table that are chained from one data block to another or that have migrated to a new block, requiring a link to preserve the old rowid  |
| AVG_ROW_LEN               | NUMBER                            | <ul style="list-style-type: none"> <li>reserved</li> </ul> Average row length, including row overhead                                                         |
| AVG_SPACE_FREELIST_BLOCKS | NUMBER                            | <ul style="list-style-type: none"> <li>reserved</li> </ul> Average freespace of all blocks on a freelist                                                      |
| NUM_FREELIST_BLOCKS       | NUMBER                            | <ul style="list-style-type: none"> <li>reserved</li> </ul> Number of blocks on the freelist                                                                   |
| DEGREE                    | VARCHAR(32)                       | <ul style="list-style-type: none"> <li>reserved</li> </ul> Number of threads per instance for scanning the table, or DEFAULT                                  |
| INSTANCES                 | VARCHAR(32)                       | <ul style="list-style-type: none"> <li>reserved</li> </ul> Number of instances across which the table is to be scanned, or DEFAULT                            |
| CACHE                     | VARCHAR(1)                        | <ul style="list-style-type: none"> <li>reserved</li> </ul> Indicates whether the table is to be cached in the buffer cache (Y) or not (N)                     |
| TABLE_LOCK                | VARCHAR(32)                       | Indicates whether table locking is enabled (ENABLED) or disabled (DISABLED)                                                                                   |
| SAMPLE_SIZE               | NUMBER                            | Sample size used in analyzing the table                                                                                                                       |
| LAST_ANALYZED             | TIMESTAMP(6)<br>WITHOUT TIME ZONE | Date on which the table was most recently analyzed                                                                                                            |
| PARTITIONED               | VARCHAR(3)                        | <ul style="list-style-type: none"> <li>reserved</li> </ul> Indicates whether the table is partitioned (YES) or not (NO)                                       |
| IOT_TYPE                  | VARCHAR(32)                       | <ul style="list-style-type: none"> <li>reserved</li> </ul> If the table is an index-organized table, then IOT_TYPE is IOT, IOT_OVERFLOW, or IOT_MAPPING.      |
| TEMPORARY                 | VARCHAR(1)                        | Indicates whether the table is temporary (Y) or not (N)                                                                                                       |
| SECONDARY                 | VARCHAR(1)                        | <ul style="list-style-type: none"> <li>reserved</li> </ul> Indicates whether the table is a secondary object created by cartridge                             |
| NESTED                    | VARCHAR(3)                        | <ul style="list-style-type: none"> <li>reserved</li> </ul> Indicates whether the table is a nested table (YES) or not (NO)                                    |
| BUFFER_POOL               | VARCHAR(32)                       | <ul style="list-style-type: none"> <li>reserved</li> </ul> Buffer pool to be used for table blocks                                                            |
| FLASH_CACHE               | VARCHAR(32)                       | <ul style="list-style-type: none"> <li>reserved</li> </ul> Database Smart Flash Cache hint to be used for table blocks                                        |
| CELL_FLASH_CACHE          | VARCHAR(32)                       | <ul style="list-style-type: none"> <li>reserved</li> </ul> Cell flash cache hint to be used for table blocks                                                  |
| ROW_MOVEMENT              | VARCHAR(32)                       | <ul style="list-style-type: none"> <li>reserved</li> </ul> If a partitioned table, indicates whether row movement is enabled (ENABLED) or disabled (DISABLED) |

| Column name     | Data type    | Description                                                                                                                                                                              |
|-----------------|--------------|------------------------------------------------------------------------------------------------------------------------------------------------------------------------------------------|
| GLOBAL_STATS    | VARCHAR(3)   | <ul style="list-style-type: none"> <li>reserved</li> </ul> For partitioned tables, indicates whether statistics for the table as a whole (global statistics) are accurate (YES)          |
| USER_STATS      | VARCHAR(3)   | <ul style="list-style-type: none"> <li>reserved</li> </ul> Indicates whether statistics were entered directly by the user (YES) or not (NO)                                              |
| DURATION        | VARCHAR(32)  | Indicates the duration of a temporary table, the value is in ( TRANSACTION, SESSION )                                                                                                    |
| SKIP_CORRUPT    | VARCHAR(32)  | <ul style="list-style-type: none"> <li>reserved</li> </ul> Indicates whether Database ignores blocks marked corrupt during table and index scans (ENABLED) or raises an error (DISABLED) |
| MONITORING      | VARCHAR(3)   | <ul style="list-style-type: none"> <li>reserved</li> </ul> Indicates whether the table has the MONITORING attribute set (YES) or not (NO)                                                |
| CLUSTER_OWNER   | VARCHAR(128) | <ul style="list-style-type: none"> <li>reserved</li> </ul> Owner of the cluster, if any                                                                                                  |
| DEPENDENCIES    | VARCHAR(32)  | <ul style="list-style-type: none"> <li>reserved</li> </ul> Indicates whether row-level dependency tracking is enabled (ENABLED) or disabled (DISABLED)                                   |
| COMPRESSION     | VARCHAR(32)  | <ul style="list-style-type: none"> <li>reserved</li> </ul> Indicates whether table compression is enabled (ENABLED) or not (DISABLED)                                                    |
| COMPRESS_FOR    | VARCHAR(32)  | <ul style="list-style-type: none"> <li>reserved</li> </ul> Default compression for what kind of operations                                                                               |
| DROPPED         | VARCHAR(3)   | Indicates whether the table has been dropped and is in the recycle bin (YES) or not (NO)                                                                                                 |
| READ_ONLY       | VARCHAR(3)   | Indicates whether the table IS READ-ONLY (YES) or not (NO)                                                                                                                               |
| SEGMENT_CREATED | VARCHAR(3)   | Indicates whether the table segment has been created (YES) or not (NO)                                                                                                                   |
| RESULT_CACHE    | VARCHAR(32)  | <ul style="list-style-type: none"> <li>reserved</li> </ul> Result cache mode annotation for the table: the value in ( NULL, DEFAULT, FORCE, MANUAL )                                     |

## USER\_TABLESPACES

USER\_TABLESPACES describes the tablespaces accessible to the current user.

**Table 9-143** Column information

| Column name              | Data type    | Description                                                                                                                                                                           |
|--------------------------|--------------|---------------------------------------------------------------------------------------------------------------------------------------------------------------------------------------|
| TABLESPACE_NAME          | VARCHAR(128) | Name of the tablespace                                                                                                                                                                |
| BLOCK_SIZE               | NUMBER       | Tablespace block size                                                                                                                                                                 |
| INITIAL_EXTENT           | NUMBER       | <ul style="list-style-type: none"> <li>reserved</li> </ul> Default initial extent size (in bytes)                                                                                     |
| NEXT_EXTENT              | NUMBER       | <ul style="list-style-type: none"> <li>reserved</li> </ul> Default incremental extent size (in bytes)                                                                                 |
| MIN_EXTENTS              | NUMBER       | <ul style="list-style-type: none"> <li>reserved</li> </ul> Default minimum number of extents                                                                                          |
| MAX_EXTENTS              | NUMBER       | <ul style="list-style-type: none"> <li>reserved</li> </ul> Default maximum number of extents                                                                                          |
| MAX_SIZE                 | NUMBER       | <ul style="list-style-type: none"> <li>reserved</li> </ul> Default maximum size of segments                                                                                           |
| PCT_INCREASE             | NUMBER       | <ul style="list-style-type: none"> <li>reserved</li> </ul> Default percent increase for extent size                                                                                   |
| MIN_EXTLEN               | NUMBER       | <ul style="list-style-type: none"> <li>reserved</li> </ul> Minimum extent size for this tablespace (in bytes)                                                                         |
| STATUS                   | VARCHAR(32)  | Tablespace status: the value in ( ONLINE, OFFLINE, READ ONLY )                                                                                                                        |
| CONTENTS                 | VARCHAR(32)  | Tablespace contents: the value in ( SYSTEM, DATA, TEMPORARY, UNDO )                                                                                                                   |
| LOGGING                  | VARCHAR(32)  | Default logging attribute: LOGGING, NOLOGGING                                                                                                                                         |
| FORCE_LOGGING            | VARCHAR(3)   | <ul style="list-style-type: none"> <li>reserved</li> </ul> Indicates whether the tablespace is under force logging mode (YES) or not (NO)                                             |
| EXTENT_MANAGEMENT        | VARCHAR(32)  | <ul style="list-style-type: none"> <li>reserved</li> </ul> Indicates whether the extents in the tablespace are dictionary managed (DICTIONARY) or locally managed (LOCAL)             |
| ALLOCATION_TYPE          | VARCHAR(32)  | <ul style="list-style-type: none"> <li>reserved</li> </ul> Type of extent allocation in effect for the tablespace: the value in ( SYSTEM, UNIFORM, USER )                             |
| SEGMENT_SPACE_MANAGEMENT | VARCHAR(32)  | <ul style="list-style-type: none"> <li>reserved</li> </ul> Indicates whether the free and used segment space in the tablespace is managed using free lists (MANUAL) or bitmaps (AUTO) |
| DEF_TAB_COMPRESSION      | VARCHAR(32)  | <ul style="list-style-type: none"> <li>reserved</li> </ul> Indicates whether default table compression is enabled (ENABLED) or not (DISABLED)                                         |
|                          |              | <ul style="list-style-type: none"> <li>reserved</li> </ul>                                                                                                                            |

| Column name          | Data type   | Description                                                                                                                                              |
|----------------------|-------------|----------------------------------------------------------------------------------------------------------------------------------------------------------|
| RETENTION            | VARCHAR(32) | Undo tablespace retention: the value in ( GUARANTEE, NOGUARANTEE, NOT APPLY )                                                                            |
| BIGFILE              | VARCHAR(3)  | <ul style="list-style-type: none"> <li>reserved</li> </ul> Indicates whether the tablespace is a bigfile tablespace (YES) or a smallfile tablespace (NO) |
| PREDICATE_EVALUATION | VARCHAR(32) | <ul style="list-style-type: none"> <li>reserved</li> </ul> Indicates whether predicates are evaluated by host (HOST) or by storage (STORAGE)             |
| ENCRYPTED            | VARCHAR(3)  | <ul style="list-style-type: none"> <li>reserved</li> </ul> Indicates whether the tablespace is encrypted (YES) or not (NO)                               |
| COMPRESS_FOR         | VARCHAR(32) | <ul style="list-style-type: none"> <li>reserved</li> </ul> Indicates whether the tablespace is encrypted (YES) or not (NO)                               |

## USER\_TAB\_COLS

USER\_TAB\_COLS describes the columns (including hidden columns) of the tables, views, and clusters owned by the current user.

**Table 9-144** Column information

| Column name          | Data type                      | Description                                                                                                                                                                                                     |
|----------------------|--------------------------------|-----------------------------------------------------------------------------------------------------------------------------------------------------------------------------------------------------------------|
| TABLE_SCHEMA         | VARCHAR(128)                   | Schema of the object                                                                                                                                                                                            |
| TABLE_NAME           | VARCHAR(128)                   | Name of the object                                                                                                                                                                                              |
| COLUMN_NAME          | VARCHAR(128)                   | Column name                                                                                                                                                                                                     |
| DATA_TYPE            | VARCHAR(128)                   | Datatype of the column                                                                                                                                                                                          |
| DATA_TYPE_MOD        | VARCHAR(3)                     | <ul style="list-style-type: none"> <li>reserved</li> </ul> Datatype modifier of the column                                                                                                                      |
| DATA_TYPE_OWNER      | VARCHAR(128)                   | <ul style="list-style-type: none"> <li>reserved</li> </ul> Owner of the datatype of the column                                                                                                                  |
| DATA_LENGTH          | NUMBER                         | Length of the column (in bytes)                                                                                                                                                                                 |
| DATA_PRECISION       | NUMBER                         | Decimal precision for NUMBER datatype; binary precision for FLOAT datatype; NULL for all other datatypes                                                                                                        |
| DATA_SCALE           | NUMBER                         | Digits to the right of the decimal point in a number                                                                                                                                                            |
| NULLABLE             | VARCHAR(1)                     | Indicates whether a column allows NULLs.                                                                                                                                                                        |
| COLUMN_ID            | NUMBER                         | Sequence number of the column as created                                                                                                                                                                        |
| DEFAULT_LENGTH       | NUMBER                         | Length of the default value for the column                                                                                                                                                                      |
| DATA_DEFAULT         | LONG VARCHAR                   | Default value for the column                                                                                                                                                                                    |
| NUM_DISTINCT         | NUMBER                         | Number of distinct values in the column                                                                                                                                                                         |
| LOW_VALUE            | VARBINARY(32)                  | Low value in the column                                                                                                                                                                                         |
| HIGH_VALUE           | VARBINARY(32)                  | High value in the column                                                                                                                                                                                        |
| DENSITY              | NUMBER                         | <ul style="list-style-type: none"> <li>reserved</li> </ul> If a histogram is available on COLUMN_NAME, then this column displays the selectivity of a value that spans fewer than 2 endpoints in the histogram. |
| NUM_NULLS            | NUMBER                         | Number of NULLs in the column                                                                                                                                                                                   |
| NUM_BUCKETS          | NUMBER                         | <ul style="list-style-type: none"> <li>reserved</li> </ul> Number of buckets in the histogram for the column                                                                                                    |
| LAST_ANALYZED        | TIMESTAMP(6) WITHOUT TIME ZONE | Date on which this column was most recently analyzed                                                                                                                                                            |
| SAMPLE_SIZE          | NUMBER                         | Sample size used in analyzing this column                                                                                                                                                                       |
| CHARACTER_SET_NAME   | VARCHAR(128)                   | <ul style="list-style-type: none"> <li>reserved</li> </ul> Name of the character set                                                                                                                            |
| CHAR_COL_DECL_LENGTH | NUMBER                         | Declaration length of the character type column                                                                                                                                                                 |
| GLOBAL_STATS         | VARCHAR(3)                     | <ul style="list-style-type: none"> <li>reserved</li> </ul> For partitioned tables, indicates whether column statistics were collected for the table                                                             |

| Column name        | Data type     | Description                                                                                                                                                        |
|--------------------|---------------|--------------------------------------------------------------------------------------------------------------------------------------------------------------------|
| USER_STATS         | VARCHAR(3)    | <ul style="list-style-type: none"> <li>reserved</li> </ul> Indicates whether statistics were entered directly by the user (YES) or not (NO)                        |
| AVG_COL_LEN        | NUMBER        | Average length of the column (in bytes)                                                                                                                            |
| CHAR_LENGTH        | NUMBER        | Displays the length of the column in characters.                                                                                                                   |
| CHAR_USED          | VARCHAR(1)    | Indicates that the column uses BYTE length semantics (B) or CHAR length semantics (C)                                                                              |
| V80_FMT_IMAGE      | VARCHAR(3)    | <ul style="list-style-type: none"> <li>reserved</li> </ul> Indicates whether the column data is in release older image format (YES) or not (NO)                    |
| DATA_UPGRADED      | VARCHAR(3)    | <ul style="list-style-type: none"> <li>reserved</li> </ul> Indicates whether the column data has been upgraded to the latest type version format (YES) or not (NO) |
| HIDDEN_COLUMN      | VARCHAR(3)    | Indicates whether the column is a hidden column (YES) or not (NO)                                                                                                  |
| VIRTUAL_COLUMN     | VARCHAR(3)    | <ul style="list-style-type: none"> <li>reserved</li> </ul> Indicates whether the column is a virtual column (YES) or not (NO)                                      |
| SEGMENT_COLUMN_ID  | NUMBER        | Sequence number of the column in the segment                                                                                                                       |
| INTERNAL_COLUMN_ID | NUMBER        | Internal sequence number of the column                                                                                                                             |
| HISTOGRAM          | VARCHAR(32)   | <ul style="list-style-type: none"> <li>reserved</li> </ul> Indicates existence/type of histogram                                                                   |
| QUALIFIED_COL_NAME | VARCHAR(4000) | Qualified column name                                                                                                                                              |
| IDENTITY_COLUMN    | VARCHAR(3)    | Indicates whether this is an identity column (YES) or not (NO)                                                                                                     |



## USER\_TAB\_COLUMNS

USER\_TAB\_COLUMNS describes the columns of the tables, views, and clusters owned by the current user.

**Table 9-145** Column information

| Column name          | Data type                       | Description                                                                                                                                                                                                     |
|----------------------|---------------------------------|-----------------------------------------------------------------------------------------------------------------------------------------------------------------------------------------------------------------|
| TABLE_SCHEMA         | VARCHAR(128)                    | Schema of the object                                                                                                                                                                                            |
| TABLE_NAME           | VARCHAR(128)                    | Name of the object                                                                                                                                                                                              |
| COLUMN_NAME          | VARCHAR(128)                    | Column name                                                                                                                                                                                                     |
| DATA_TYPE            | VARCHAR(128)                    | Datatype of the column                                                                                                                                                                                          |
| DATA_TYPE_MOD        | VARCHAR(3)                      | <ul style="list-style-type: none"> <li>reserved</li> </ul> Datatype modifier of the column                                                                                                                      |
| DATA_TYPE_OWNER      | VARCHAR(128)                    | <ul style="list-style-type: none"> <li>reserved</li> </ul> Owner of the datatype of the column                                                                                                                  |
| DATA_LENGTH          | NUMBER                          | Length of the column (in bytes)                                                                                                                                                                                 |
| DATA_PRECISION       | NUMBER                          | Decimal precision for NUMBER datatype; binary precision for FLOAT datatype; NULL for all other datatypes                                                                                                        |
| DATA_SCALE           | NUMBER                          | Digits to the right of the decimal point in a number                                                                                                                                                            |
| NULLABLE             | VARCHAR(1)                      | Indicates whether a column allows NULLs.                                                                                                                                                                        |
| COLUMN_ID            | NUMBER                          | Sequence number of the column as created                                                                                                                                                                        |
| DEFAULT_LENGTH       | NUMBER                          | Length of the default value for the column                                                                                                                                                                      |
| DATA_DEFAULT         | LONG VARCHAR                    | Default value for the column                                                                                                                                                                                    |
| NUM_DISTINCT         | NUMBER                          | Number of distinct values in the column                                                                                                                                                                         |
| LOW_VALUE            | VARBINARY(32)                   | Low value in the column                                                                                                                                                                                         |
| HIGH_VALUE           | VARBINARY(32)                   | High value in the column                                                                                                                                                                                        |
| DENSITY              | NUMBER                          | <ul style="list-style-type: none"> <li>reserved</li> </ul> If a histogram is available on COLUMN_NAME, then this column displays the selectivity of a value that spans fewer than 2 endpoints in the histogram. |
| NUM_NULLS            | NUMBER                          | Number of NULLs in the column                                                                                                                                                                                   |
| NUM_BUCKETS          | NUMBER                          | <ul style="list-style-type: none"> <li>reserved</li> </ul> Number of buckets in the histogram for the column                                                                                                    |
| LAST_ANALYZED        | TIMESTAMP(6) WITH OUT TIME ZONE | Date on which this column was most recently analyzed                                                                                                                                                            |
| SAMPLE_SIZE          | NUMBER                          | Sample size used in analyzing this column                                                                                                                                                                       |
| CHARACTER_SET_NAME   | VARCHAR(128)                    | <ul style="list-style-type: none"> <li>reserved</li> </ul> Name of the character set                                                                                                                            |
| CHAR_COL_DECL_LENGTH | NUMBER                          | Declaration length of the character type column                                                                                                                                                                 |
| GLOBAL_STATS         | VARCHAR(3)                      | <ul style="list-style-type: none"> <li>reserved</li> </ul> For partitioned tables, indicates whether column statistics were collected for the table                                                             |

| Column name     | Data type   | Description                                                                                                                                                        |
|-----------------|-------------|--------------------------------------------------------------------------------------------------------------------------------------------------------------------|
| USER_STATS      | VARCHAR(3)  | <ul style="list-style-type: none"> <li>reserved</li> </ul> Indicates whether statistics were entered directly by the user (YES) or not (NO)                        |
| AVG_COL_LEN     | NUMBER      | Average length of the column (in bytes)                                                                                                                            |
| CHAR_LENGTH     | NUMBER      | Displays the length of the column in characters.                                                                                                                   |
| CHAR_USED       | VARCHAR(1)  | Indicates that the column uses BYTE length semantics (B) or CHAR length semantics (C)                                                                              |
| V80_FMT_IMAGE   | VARCHAR(3)  | <ul style="list-style-type: none"> <li>reserved</li> </ul> Indicates whether the column data is in release older image format (YES) or not (NO)                    |
| DATA_UPGRADED   | VARCHAR(3)  | <ul style="list-style-type: none"> <li>reserved</li> </ul> Indicates whether the column data has been upgraded to the latest type version format (YES) or not (NO) |
| HISTOGRAM       | VARCHAR(32) | <ul style="list-style-type: none"> <li>reserved</li> </ul> Indicates existence/type of histogram                                                                   |
| IDENTITY_COLUMN | VARCHAR(3)  | Indicates whether this is an identity column (YES) or not (NO)                                                                                                     |

## USER\_TAB\_COMMENTS

USER\_TAB\_COMMENTS displays comments on the tables and views owned by the current user.

**Table 9-146** Column information

| Column name  | Data type     | Description           |
|--------------|---------------|-----------------------|
| TABLE_SCHEMA | VARCHAR(128)  | Schema of the object  |
| TABLE_NAME   | VARCHAR(128)  | Name of the object    |
| TABLE_TYPE   | VARCHAR(32)   | Type of the object    |
| COMMENTS     | VARCHAR(1024) | Comment on the object |

## USER\_TAB\_IDENTITY\_COLS

USER\_TAB\_IDENTITY\_COLS describes all table identity columns.

**Table 9-147** Column information

| Column name      | Data type     | Description                                                                      |
|------------------|---------------|----------------------------------------------------------------------------------|
| TABLE_SCHEMA     | VARCHAR(128)  | Schema of the table                                                              |
| TABLE_NAME       | VARCHAR(128)  | Name of the table                                                                |
| COLUMN_NAME      | VARCHAR(128)  | Name of the identity column                                                      |
| GENERATION_TYPE  | VARCHAR(32)   | Generation type of the identity column. Possible values are ALWAYS or BY DEFAULT |
| IDENTITY_OPTIONS | VARCHAR(1024) | Options for the identity column sequence generator                               |

## USER\_TAB\_PLACE

USER\_TAB\_PLACE describes node placement of cluster tables owned by the current user in the cluster system.



It is available only on a cluster.

**Table 9-148** Column information

| Column name      | Data type                          | Description                                                                              |
|------------------|------------------------------------|------------------------------------------------------------------------------------------|
| TABLE_SCHEMA     | VARCHAR(128)                       | Schema of the table                                                                      |
| TABLE_NAME       | VARCHAR(128)                       | Name of the table                                                                        |
| GROUP_ID         | NUMBER                             | Group identifier of the node where the table placed                                      |
| GROUP_NAME       | VARCHAR(128)                       | Group name of the node where the table placed                                            |
| MEMBER_ID        | NUMBER                             | Member identifier of the node where the table placed                                     |
| MEMBER_NAME      | VARCHAR(128)                       | Member name of the node where the table placed                                           |
| MEMBER_POSITION  | NUMBER                             | Member position of the node where the table placed                                       |
| MEMBER_OFFLINE   | BOOLEAN                            | data of the cluster member is offline or not                                             |
| IS_UPDATE_MASTER | BOOLEAN                            | whether the cluster member is update master or not                                       |
| DROPPED          | VARCHAR(3)                         | Indicates whether the table has been dropped and is in the recycle bin (YES) or not (NO) |
| SCN              | VARCHAR(64)                        | table scn of the node where the table placed                                             |
| NUM_ROWS         | NUMBER                             | Number of rows in the table                                                              |
| BLOCKS           | NUMBER                             | Number of used blocks of the node where the table placed                                 |
| LAST_ANALYZED    | TIMESTAMP(6) WITH<br>OUT TIME ZONE | Date on which the table was most recently analyzed                                       |

## USER\_TAB\_PRIVS

USER\_TAB\_PRIVS describes the object grants for which the current user is the object owner, grantor, or grantee.

**Table 9-149** Column information

| Column name  | Data type    | Description                                                                             |
|--------------|--------------|-----------------------------------------------------------------------------------------|
| GRANTEE      | VARCHAR(128) | Name of the user or role to whom access was granted                                     |
| OWNER        | VARCHAR(128) | Owner of the object                                                                     |
| TABLE_SCHEMA | VARCHAR(128) | Schema of the object                                                                    |
| TABLE_NAME   | VARCHAR(128) | Name of the object                                                                      |
| GRANTOR      | VARCHAR(128) | Name of the user who performed the grant                                                |
| PRIVILEGE    | VARCHAR(32)  | Privilege on the object                                                                 |
| GRANTABLE    | VARCHAR(3)   | Indicates whether the privilege was granted with the GRANT OPTION (YES) or not (NO)     |
| HIERARCHY    | VARCHAR(3)   | Indicates whether the privilege was granted with the HIERARCHY OPTION (YES) or not (NO) |

## USER\_TAB\_PRIVS\_MADE

USER\_TAB\_PRIVS\_MADE describes the object grants for which the current user is the object owner.

**Table 9-150** Column information

| Column name  | Data type    | Description                                                                             |
|--------------|--------------|-----------------------------------------------------------------------------------------|
| GRANTEE      | VARCHAR(128) | Name of the user or role to whom access was granted                                     |
| TABLE_SCHEMA | VARCHAR(128) | Schema of the object                                                                    |
| TABLE_NAME   | VARCHAR(128) | Name of the object                                                                      |
| GRANTOR      | VARCHAR(128) | Name of the user who performed the grant                                                |
| PRIVILEGE    | VARCHAR(32)  | Privilege on the object                                                                 |
| GRANTABLE    | VARCHAR(3)   | Indicates whether the privilege was granted with the GRANT OPTION (YES) or not (NO)     |
| HIERARCHY    | VARCHAR(3)   | Indicates whether the privilege was granted with the HIERARCHY OPTION (YES) or not (NO) |

## USER\_TAB\_PRIVS\_RECD

USER\_TAB\_PRIVS\_RECD describes the object grants for which the current user is the grantee.

**Table 9-151** Column information

| Column name  | Data type    | Description                                                                             |
|--------------|--------------|-----------------------------------------------------------------------------------------|
| OWNER        | VARCHAR(128) | Owner of the object                                                                     |
| TABLE_SCHEMA | VARCHAR(128) | Schema of the object                                                                    |
| TABLE_NAME   | VARCHAR(128) | Name of the object                                                                      |
| GRANTOR      | VARCHAR(128) | Name of the user who performed the grant                                                |
| PRIVILEGE    | VARCHAR(32)  | Privilege on the object                                                                 |
| GRANTABLE    | VARCHAR(3)   | Indicates whether the privilege was granted with the GRANT OPTION (YES) or not (NO)     |
| HIERARCHY    | VARCHAR(3)   | Indicates whether the privilege was granted with the HIERARCHY OPTION (YES) or not (NO) |



## USER\_TAB\_SHARDS

USER\_TAB\_SHARDS describes shard information of sharded tables owned by the current user in the cluster system.



It is available only on a cluster.

**Table 9-152** Column information

| Column name      | Data type    | Description                                                                                    |
|------------------|--------------|------------------------------------------------------------------------------------------------|
| TABLE_SCHEMA     | VARCHAR(128) | Schema of the table                                                                            |
| TABLE_NAME       | VARCHAR(128) | Name of the table                                                                              |
| SHARD_STRATEGY   | VARCHAR(32)  | Sharding strategy of the table:<br>the value in (HASH SHARDING, RANGE SHARDING, LIST SHARDING) |
| SHARD_NAME       | VARCHAR(128) | Shard name                                                                                     |
| SHARD_NUMBER     | NUMBER       | Shard number                                                                                   |
| SHARD_DEFINITION | LONG VARCHAR | Shard definition (if hash sharded, the value is null)                                          |
| GROUP_ID         | NUMBER       | Group identifier where the shard placed                                                        |
| GROUP_NAME       | VARCHAR(128) | Group Name where the shard placed                                                              |
| DROPPED          | VARCHAR(3)   | Indicates whether the table has been dropped and is in the recycle bin (YES) or not (NO)       |

## USER\_USERS

USER\_USERS describes the current user.

**Table 9-153** Column information

| Column name                 | Data type                          | Description                                                                                                                                                                               |
|-----------------------------|------------------------------------|-------------------------------------------------------------------------------------------------------------------------------------------------------------------------------------------|
| USERNAME                    | VARCHAR(128)                       | Name of the user                                                                                                                                                                          |
| USER_ID                     | NUMBER                             | ID number of the user                                                                                                                                                                     |
| ACCOUNT_STATUS              | VARCHAR(32)                        | Account status: the value in ( OPEN, EXPIRED, EXPIRED(GRACE), LOCKED(TIMED), LOCKED, EXPIRED & LOCKED(TIMED), EXPIRED(GRACE) & LOCKED(TIMED), EXPIRED & LOCKED, EXPIRED(GRACE) & LOCKED ) |
| LOCK_DATE                   | TIMESTAMP(2) WITH<br>OUT TIME ZONE | Timestamp the account was locked if account status was LOCKED                                                                                                                             |
| EXPIRY_DATE                 | TIMESTAMP(2) WITH<br>OUT TIME ZONE | Timestamp of expiration of the account                                                                                                                                                    |
| DEFAULT_TABLESPACE          | VARCHAR(128)                       | Default tablespace for data                                                                                                                                                               |
| TEMPORARY_TABLESPACE        | VARCHAR(128)                       | Name of the default tablespace for temporary tables or the name of a tablespace group                                                                                                     |
| INDEX_TABLESPACE            | VARCHAR(128)                       | Default tablespace for index                                                                                                                                                              |
| CREATED                     | TIMESTAMP(2) WITH<br>OUT TIME ZONE | User creation timestamp                                                                                                                                                                   |
| INITIAL_RSRC_CONSUMER_GROUP | VARCHAR(128)                       | <ul style="list-style-type: none"> <li>reserved</li> </ul> Initial resource consumer group for the user                                                                                   |
| EXTERNAL_NAME               | VARCHAR(128)                       | <ul style="list-style-type: none"> <li>reserved</li> </ul> User external name                                                                                                             |

## USER\_VIEWS

USER\_VIEWS describes the views owned by the current user.

**Table 9-154** Column information

| Column name      | Data type     | Description                                                                                                          |
|------------------|---------------|----------------------------------------------------------------------------------------------------------------------|
| VIEW_SCHEMA      | VARCHAR(128)  | Schema of the view                                                                                                   |
| VIEW_NAME        | VARCHAR(128)  | Name of the view                                                                                                     |
| TEXT_LENGTH      | NUMBER        | Length of the view text                                                                                              |
| TEXT             | LONG VARCHAR  | View text                                                                                                            |
| TYPE_TEXT_LENGTH | NUMBER        | <ul style="list-style-type: none"> <li>reserved</li> </ul> Length of the type clause of the typed view               |
| TYPE_TEXT        | VARCHAR(4000) | <ul style="list-style-type: none"> <li>reserved</li> </ul> Type clause of the typed view                             |
| OID_TEXT_LENGTH  | NUMBER        | <ul style="list-style-type: none"> <li>reserved</li> </ul> Length of the WITH OID clause of the typed view           |
| OID_TEXT         | VARCHAR(4000) | <ul style="list-style-type: none"> <li>reserved</li> </ul> WITH OID clause of the typed view                         |
| VIEW_TYPE_OWNER  | VARCHAR(128)  | <ul style="list-style-type: none"> <li>reserved</li> </ul> Owner of the type of the view if the view is a typed view |
| VIEW_TYPE        | VARCHAR(32)   | <ul style="list-style-type: none"> <li>reserved</li> </ul> Type of the view if the view is a typed view              |
| SUPERVIEW_NAME   | VARCHAR(128)  | <ul style="list-style-type: none"> <li>reserved</li> </ul> Name of the superview                                     |
| EDITIONING_VIEW  | VARCHAR(1)    | Reserved for future use                                                                                              |
| READ_ONLY        | VARCHAR(1)    | Indicates whether the view is read-only (Y) or not (N)                                                               |

## Other Views

There are other views or tables which are none of All-family, DBA-family or USER-family.

### AUDIT\_POLICIES

AUDIT\_POLICIES contains one row for each audit policy.

**Table 9-155** Column information

| Column name   | Data type                          | Description                                                     |
|---------------|------------------------------------|-----------------------------------------------------------------|
| POLICY_NAME   | VARCHAR(128)                       | audit policy name                                               |
| ENABLED       | VARCHAR(3)                         | indicates whether the audit policy is enabled (YES) or not (NO) |
| CREATED_TIME  | TIMESTAMP(2) WITH<br>OUT TIME ZONE | created time of the audit policy                                |
| MODIFIED_TIME | TIMESTAMP(2) WITH<br>OUT TIME ZONE | last modified time of the audit policy                          |
| COMMENTS      | VARCHAR(1024)                      | comments of the audit policy                                    |

## AUDIT\_POLICY\_OPTIONS

AUDIT\_POLICY\_OPTIONS describes all audit policies created in the database.

**Table 9-156** Column information

| Column name       | Data type    | Description                                                                                        |
|-------------------|--------------|----------------------------------------------------------------------------------------------------|
| POLICY_NAME       | VARCHAR(128) | audit policy name                                                                                  |
| AUDIT_OPTION      | VARCHAR(32)  | auditing option defined in the audit policy                                                        |
| AUDIT_OPTION_TYPE | VARCHAR(32)  | The values of AUDIT_OPTION_TYPE_NAME in ( 'DATABASE PRIVILEGE', 'SYSTEM ACTION', 'OBJECT ACTION' ) |
| OBJECT_SCHEMA     | VARCHAR(128) | schema name, for an object-specific auditing option                                                |
| OBJECT_NAME       | VARCHAR(128) | object name, for an object-specific auditing option                                                |
| OBJECT_TYPE       | VARCHAR(32)  | object type name, for an object-specific auditing option                                           |
| DROPPED           | VARCHAR(3)   | Indicates whether the object has been dropped and is in the recycle bin (YES) or not (NO)          |

## AUDIT\_POLICY\_ENABLED

AUDIT\_POLICY\_ENABLE describes all the audit policies that are enable in the database.

**Table 9-157** Column information

| Column name  | Data type    | Description                                                                          |
|--------------|--------------|--------------------------------------------------------------------------------------|
| POLICY_NAME  | VARCHAR(128) | audit policy name                                                                    |
| ENABLED_OPT  | VARCHAR(32)  | enable option of the audit policy, the possible values are BY, EXCEPT                |
| USER_NAME    | VARCHAR(128) | user name for whom the audit policy is enable                                        |
| WHEN_SUCCESS | VARCHAR(3)   | indicates whether the audit policy is enable for auditing successful events or not   |
| WHEN_FAILURE | VARCHAR(3)   | indicates whether the audit policy is enable for auditing unsuccessful events or not |

## AUDIT\_TRAIL

AUDIT\_TRAIL displays audit records from the audit trail.

**Table 9-158** Column information

| Column name         | Data type                      | Description                                                             |
|---------------------|--------------------------------|-------------------------------------------------------------------------|
| MEMBER_NAME         | VARCHAR(128)                   | cluster member name                                                     |
| SESSION_ID          | NUMBER                         | session identifier                                                      |
| SESSION_SERIAL      | NUMBER                         | session serial number                                                   |
| LOGON_USERNAME      | VARCHAR(128)                   | logon user name of the user whose actions were audited                  |
| CURRENT_USERNAME    | VARCHAR(128)                   | effective user for the statement execution                              |
| SERVER_PROCESS      | NUMBER                         | server process identifier for the session                               |
| CLIENT_PROGRAM_NAME | VARCHAR(128)                   | client program used for session                                         |
| CLIENT_USERNAME     | VARCHAR(128)                   | client operating system user name for the session                       |
| CLIENT_PROCESS      | NUMBER                         | client process identifier for the session                               |
| CLIENT_HOST         | VARCHAR(128)                   | client host ip address for the session                                  |
| CLIENT_PORT         | NUMBER                         | client port number for the session                                      |
| CLIENT_TERMINAL     | VARCHAR(128)                   | client terminal name for the session                                    |
| TRANSACTION_ID      | NUMBER                         | transaction identifier                                                  |
| SCN                 | VARCHAR(128)                   | system change number (SCN) string of the query at the time of the event |
| GCN                 | NUMBER                         | global change number (GCN) of the query at the time of the event        |
| DCN                 | NUMBER                         | domain change number (DCN) of the query at the time of the event        |
| LCN                 | NUMBER                         | local change number (LCN) of the query at the time of the event         |
| STMT_NO             | NUMBER                         | numeric number for each statement run in a session                      |
| SQL_TEXT            | LONG VARCHAR                   | SQL associated with the event                                           |
| SQL_BINDS           | LONG VARCHAR                   | list of bind variables, if any, associated with SQL_TEXT                |
| RETURN_CODE         | NUMBER                         | error code generated by the action, zero if the action succeeded        |
| ERROR_MESSAGE       | VARCHAR(1024)                  | error message generated by the action, null if the action succeeded     |
| ENTRY_ID            | NUMBER                         | audit trail entry identifier in the session                             |
| EVENT_TIMESTAMP     | TIMESTAMP(2) WITHOUT TIME ZONE | timestamp of the creation of the audit trail entry in local time zone   |
| POLICY_NAME         | VARCHAR(128)                   | audit policy name that caused the current audit record                  |
| PRIVILEGE_USED      | VARCHAR(32)                    | database privilege used to execute the action                           |
| ACTION_NAME         | VARCHAR(32)                    | action name executed by the user                                        |

| Column name   | Data type    | Description                                  |
|---------------|--------------|----------------------------------------------|
| OBJECT_TYPE   | VARCHAR(32)  | object type of object affected by the action |
| OBJECT_SCHEMA | VARCHAR(128) | schema name of object affected by the action |
| OBJECT_NAME   | VARCHAR(128) | object name of object affected by the action |



## DATABASE\_PROPERTIES

DATABASE\_PROPERTIES lists permanent database properties.

**Table 9-159** Column information

| Column name    | Data type     | Description          |
|----------------|---------------|----------------------|
| PROPERTY_NAME  | VARCHAR(128)  | Property name        |
| PROPERTY_VALUE | VARCHAR(4000) | Property value       |
| DESCRIPTION    | VARCHAR(4000) | Property description |

## DBC\_TABLE\_TYPE\_INFO

Identify the ODBC/JDBC table types available in this database.

**Table 9-160** Column information

| Column name       | Data type     | Description                                      |
|-------------------|---------------|--------------------------------------------------|
| DBC_TABLE_TYPE_ID | NUMBER        | number identifier of the table type in ODBC/JDBC |
| DBC_TABLE_TYPE    | VARCHAR(128)  | name of the table type in ODBC/JDBC              |
| IS_SUPPORTED      | BOOLEAN       | is supported feature                             |
| COMMENTS          | VARCHAR(1024) | comments of the table type                       |

## DICTIONARY

DICTIONARY contains descriptions of data dictionary tables and views.

**Table 9-161** Column information

| Column name  | Data type     | Description                |
|--------------|---------------|----------------------------|
| TABLE_SCHEMA | VARCHAR(128)  | Schema of the object       |
| TABLE_NAME   | VARCHAR(128)  | Name of the object         |
| COMMENTS     | VARCHAR(1024) | Text comment on the object |

## DICT\_COLUMNS

DICT\_COLUMNS contains descriptions of columns in data dictionary tables and views.

**Table 9-162** Column information

| Column name  | Data type     | Description                                   |
|--------------|---------------|-----------------------------------------------|
| TABLE_SCHEMA | VARCHAR(128)  | Schema of the object that contains the column |
| TABLE_NAME   | VARCHAR(128)  | Name of the object that contains the column   |
| COLUMN_NAME  | VARCHAR(128)  | Name of the column                            |
| COMMENTS     | VARCHAR(1024) | Text comment on the column                    |

## IMPLEMENTATION\_INFO

IMPLEMENTATION\_INFO contains information about various aspects that are left implementation-defined.

**Table 9-163** Column information

| Column name              | Data type     | Description                                                                                       |
|--------------------------|---------------|---------------------------------------------------------------------------------------------------|
| IMPLEMENTATION_INFO_ID   | NUMBER        | identifier of the implementation item                                                             |
| IMPLEMENTATION_INFO_NAME | VARCHAR(1024) | descriptive name of the implementation item                                                       |
| INTEGER_VALUE            | NUMBER        | Value of the implementation item, or null if the value is contained in the column CHARACTER_VALUE |
| CHARACTER_VALUE          | VARCHAR(1024) | Value of the implementation item, or null if the value is contained in the column INTEGER_VALUE   |
| COMMENTS                 | VARCHAR(1024) | possibly a comment pertaining to the implementation item                                          |

## IMPLEMENTATION\_INFO\_BASE

The IMPLEMENTATION\_INFO\_BASE table has one row for each implementation information item.

**Table 9-164** Column information

| Column name     | Data type     | Description                                                                                       |
|-----------------|---------------|---------------------------------------------------------------------------------------------------|
| ID              | VARCHAR(32)   | identifier string of the implementation item                                                      |
| SUB_ID          | VARCHAR(32)   | identifier string of the implementation item                                                      |
| NAME            | VARCHAR(1024) | descriptive name of the implementation item                                                       |
| SUB_NAME        | VARCHAR(1024) | descriptive name of the implementation item                                                       |
| IS_SUPPORTED    | BOOLEAN       | TRUE if the implementation item is supported, FALSE if not                                        |
| INTEGER_VALUE   | NUMBER        | Value of the implementation item, or null if the value is contained in the column CHARACTER_VALUE |
| CHARACTER_VALUE | VARCHAR(1024) | Value of the implementation item, or null if the value is contained in the column INTEGER_VALUE   |
| COMMENTS        | VARCHAR(1024) | possibly a comment pertaining to the implementation item                                          |

## JDBC\_CLIENT\_PROPS

JDBC\_CLIENT\_PROPS is the set of jdbc client properties.

**Table 9-165** Column information

| Column name   | Data type      | Description                  |
|---------------|----------------|------------------------------|
| NAME          | VARCHAR(128)   | property name                |
| MAX_LEN       | NATIVE_INTEGER | max length of a value        |
| DEFAULT_VALUE | VARCHAR(128)   | default value                |
| DESCRIPTION   | VARCHAR(256)   | description on that property |

## PRODUCT

PRODUCT is about the product name, version for ODBC, JDBC interface.

**Table 9-166** Column information

| Column name     | Data type    | Description                      |
|-----------------|--------------|----------------------------------|
| NAME            | VARCHAR(32)  | the product name                 |
| VERSION         | VARCHAR(128) | product full version information |
| PRODUCT_VERSION | NUMBER       | product version                  |
| MAJOR_VERSION   | NUMBER       | major version                    |
| MINOR_VERSION   | NUMBER       | minor version                    |
| PATCH_VERSION   | NUMBER       | patch version                    |



## SESSION\_PRIVS

SESSION\_PRIVS describes the privileges that are currently available to the user.

**Table 9-167** Column information

| Column name | Data type    | Description           |
|-------------|--------------|-----------------------|
| PRIVILEGE   | VARCHAR(256) | Name of the privilege |

## SUPPLEMENTAL\_LOG\_TABLE\_INFO

SUPPLEMENTAL\_LOG\_TABLE\_INFO describes table-level supplemental logging status.

**Table 9-168** Column information

| Column name              | Data type    | Description                                                                               |
|--------------------------|--------------|-------------------------------------------------------------------------------------------|
| TABLE_SCHEMA             | VARCHAR(128) | Schema of the object                                                                      |
| TABLE_NAME               | VARCHAR(128) | Name of the object                                                                        |
| SUPPLEMENTAL_LOG_DATA_PK | VARCHAR(32)  | Status of table-level PRIMARY KEY COLUMNS supplemental logging: IMPLICIT, EXPLICIT, NO    |
| DROPPED                  | VARCHAR(3)   | Indicates whether the object has been dropped and is in the recycle bin (YES) or not (NO) |

## Aliased Synonym

It is the public synonym which indicates the view or table in DICTIONARY\_SCHEMA.

### COLS

COLS is a public synonym for USER\_TAB\_COLUMNS.

### DICT

DICT is a public synonym for DICTIONARY.

### IND

IND is a public synonym for USER\_INDEXES.

### OBJ

OBJ is a public synonym for USER\_OBJECTS.

### SEQ

SEQ is a public synonym for USER\_SEQUENCES.

### TABS

TABS is a public synonym for USER\_TABLES.

### RECYCLEBIN

RECYCLEBIN is a public synonym for USER\_RECYCLEBIN.

## 9.2 INFORMATION\_SCHEMA

Views of INFORMATION\_SCHEMA schema provides the same information as those defined in the SQL standard.

Execute *InformationSchema.sql* as follows to use the views.

- For standalone

```
% gsql sys gliese --as sysdba --import  
$GOLDILOCKS_HOME/admin/standalone/InformationSchema.sql
```

- For cluster

```
% gsql sys gliese --as sysdba --import $GOLDILOCKS_HOME/admin/cluster/InformationSchema.sql
```



- Views and tables of INFORMATION\_SCHEMA can be retrieved from OPEN phase.
- Objects stored in the recyclebin can not be retrieved in the view of INFORMATION\_SCHEMA.

# COLUMNS

Identify the columns of tables defined in this catalog that are accessible to given user or role.

**Table 9-169** Column information

| Column name              | Data type    | Description                                                                                                                                                                                 |
|--------------------------|--------------|---------------------------------------------------------------------------------------------------------------------------------------------------------------------------------------------|
| TABLE_CATALOG            | VARCHAR(128) | catalog name of the column                                                                                                                                                                  |
| TABLE_OWNER              | VARCHAR(128) | owner name of the column                                                                                                                                                                    |
| TABLE_SCHEMA             | VARCHAR(128) | schema name of the column                                                                                                                                                                   |
| TABLE_NAME               | VARCHAR(128) | table name of the column                                                                                                                                                                    |
| COLUMN_NAME              | VARCHAR(128) | column name                                                                                                                                                                                 |
| ORDINAL_POSITION         | NUMBER       | the ordinal position (> 0) of the column in the table                                                                                                                                       |
| COLUMN_DEFAULT           | LONG VARCHAR | the default for the column                                                                                                                                                                  |
| IS_NULLABLE              | BOOLEAN      | is nullable of the column                                                                                                                                                                   |
| DATA_TYPE                | VARCHAR(128) | the standard name of the data type                                                                                                                                                          |
| CHARACTER_MAXIMUM_LENGTH | NUMBER       | the maximum length in characters                                                                                                                                                            |
| CHARACTER_OCTET_LENGTH   | NUMBER       | the maximum length in octets                                                                                                                                                                |
| NUMERIC_PRECISION        | NUMBER       | the numeric precision of the numerical Data type                                                                                                                                            |
| NUMERIC_PRECISION_RADIX  | NUMBER       | the radix ( 2 or 10 ) of the precision of the numerical data type                                                                                                                           |
| NUMERIC_SCALE            | NUMBER       | the numeric scale of the exact numerical data type                                                                                                                                          |
| DATETIME_PRECISION       | NUMBER       | for a datetime or interval type, the value is the fractional seconds precision                                                                                                              |
| INTERVAL_TYPE            | VARCHAR(32)  | for a interval type, the value is in ( YEAR, MONTH, DAY, HOUR, MINUTE, SECOND, YEAR TO MONTH, DAY TO HOUR, DAY TO MINUTE, DAY TO SECOND, HOUR TO MINUTE, HOUR TO SECOND, MINUTE TO SECOND ) |
| INTERVAL_PRECISION       | NUMBER       | for a interval type, the value is the leading precision                                                                                                                                     |
| CHARACTER_SET_CATALOG    | VARCHAR(128) | catalog name of the character set if is is a character string type                                                                                                                          |
| CHARACTER_SET_SCHEMA     | VARCHAR(128) | schema name of the character set if is is a character string type                                                                                                                           |
| CHARACTER_SET_NAME       | VARCHAR(128) | character set name of the character set if is is a character string type                                                                                                                    |
| COLLATION_CATALOG        | VARCHAR(128) | catalog name of the applicable collation if is is a character string type                                                                                                                   |
| COLLATION_SCHEMA         | VARCHAR(128) | schema name of the applicable collation if is is a character string type                                                                                                                    |
| COLLATION_NAME           | VARCHAR(128) | collation name of the applicable collation if is is a character                                                                                                                             |

| Column name                         | Data type    | Description                                                                      |
|-------------------------------------|--------------|----------------------------------------------------------------------------------|
|                                     |              | string type                                                                      |
| DOMAIN_CATALOG                      | VARCHAR(128) | catalog name of the domain used by the column being described                    |
| DOMAIN_SCHEMA                       | VARCHAR(128) | schema name of the domain used by the column being described                     |
| DOMAIN_NAME                         | VARCHAR(128) | domain name of the domain used by the column being described                     |
| UDT_CATALOG                         | VARCHAR(128) | catalog name of the user-defined type of the data type being described           |
| UDT_SCHEMA                          | VARCHAR(128) | schema name of the user-defined type of the data type being described            |
| UDT_NAME                            | VARCHAR(128) | user-defined type name of the user-defined type of the data type being described |
| SCOPE_CATALOG                       | VARCHAR(128) | catalog name of the referenceable table if DATA_TYPE is REF                      |
| SCOPE_SCHEMA                        | VARCHAR(128) | schema name of the referenceable table if DATA_TYPE is REF                       |
| SCOPE_NAME                          | VARCHAR(128) | scope name of the referenceable table if DATA_TYPE is REF                        |
| MAXIMUM_CARDINALITY                 | NUMBER       | maximum cardinality if DATA_TYPE is ARRAY                                        |
| DTD_IDENTIFIER                      | NUMBER       | data type descriptor identifier                                                  |
| IS_SELF_REFERENCING                 | BOOLEAN      | is a self-referencing column                                                     |
| IS_IDENTITY                         | BOOLEAN      | is an identity column                                                            |
| IDENTITY_GENERATION                 | VARCHAR(32)  | for an identity column, the value is in ( ALWAYS, BY DEFAULT )                   |
| IDENTITY_START                      | NUMBER       | for an identity column, the start value of the identity column                   |
| IDENTITY_INCREMENT                  | NUMBER       | for an identity column, the increment of the identity column                     |
| IDENTITY_MAXIMUM                    | NUMBER       | for an identity column, the maximum value of the identity column                 |
| IDENTITY_MINIMUM                    | NUMBER       | for an identity column, the minimum value of the identity column                 |
| IDENTITY_CYCLE                      | BOOLEAN      | for an identity column, the cycle option                                         |
| IS_GENERATED                        | BOOLEAN      | is a generated column                                                            |
| GENERATION_EXPRESSION               | VARCHAR(128) | for a generated column, the text of the generation expression                    |
| IS_SYSTEM_VERSION_START             | BOOLEAN      | is a system-version start column                                                 |
| IS_SYSTEM_VERSION_END               | BOOLEAN      | is a system-version end column                                                   |
| SYSTEM_VERSION_TIMESTAMP_GENERATION | VARCHAR(32)  | for a system-version column, the value is ALWAYS                                 |
| IS_UPDATABLE                        | BOOLEAN      | is an updatable column                                                           |
| DECLARED_DATA_TYPE                  | VARCHAR(128) | the data type name that a user declared                                          |

| Column name                | Data type     | Description                              |
|----------------------------|---------------|------------------------------------------|
| DECLARED_NUMERIC_PRECISION | NUMBER        | the precision value that a user declared |
| DECLARED_NUMERIC_SCALE     | NUMBER        | the scale value that a user declared     |
| COMMENTS                   | VARCHAR(1024) | comments of the column                   |

## COLUMN\_PRIVILEGES

Identify the privileges on columns of tables defined in this catalog that are available to or granted by a given user or role.

**Table 9-170** Column information

| Column name    | Data type    | Description                                                                                                                       |
|----------------|--------------|-----------------------------------------------------------------------------------------------------------------------------------|
| GRANTOR        | VARCHAR(128) | authorization name of the user who granted column privileges                                                                      |
| GRANTEE        | VARCHAR(128) | authorization name of some user or role, or PUBLIC to indicate all users, to whom the column privilege being described is granted |
| TABLE_CATALOG  | VARCHAR(128) | catalog name of the column on which the privilege being described was granted                                                     |
| TABLE_OWNER    | VARCHAR(128) | table owner name of the column on which the privilege being described was granted                                                 |
| TABLE_SCHEMA   | VARCHAR(128) | schema name of the column on which the privilege being described was granted                                                      |
| TABLE_NAME     | VARCHAR(128) | table name of the column on which the privilege being described was granted                                                       |
| COLUMN_NAME    | VARCHAR(128) | column name of the column on which the privilege being described was granted                                                      |
| PRIVILEGE_TYPE | VARCHAR(32)  | the value is in ( SELECT, INSERT, UPDATE, REFERENCES )                                                                            |
| IS_GRANTABLE   | BOOLEAN      | is grantable                                                                                                                      |



## CONSTRAINT\_COLUMN\_USAGE

Identify the columns used by referential constraints, unique constraints, check constraints, and assertions defined in this catalog and owned by a given user or role.

**Table 9-171** Column information

| Column name        | Data type    | Description                                                                    |
|--------------------|--------------|--------------------------------------------------------------------------------|
| TABLE_CATALOG      | VARCHAR(128) | catalog name of the column that participates in the constraint being described |
| TABLE_OWNER        | VARCHAR(128) | owner name of the column that participates in the constraint being described   |
| TABLE_SCHEMA       | VARCHAR(128) | schema name of the column that participates in the constraint being described  |
| TABLE_NAME         | VARCHAR(128) | table name of the column that participates in the constraint being described   |
| COLUMN_NAME        | VARCHAR(128) | column name that participates in the constraint being described                |
| CONSTRAINT_CATALOG | VARCHAR(128) | catalog name of the constraint                                                 |
| CONSTRAINT_OWNER   | VARCHAR(128) | owner name of the constraint                                                   |
| CONSTRAINT_SCHEMA  | VARCHAR(128) | schema name of the constraint                                                  |
| CONSTRAINT_NAME    | VARCHAR(128) | constraint name                                                                |

## CONSTRAINT\_TABLE\_USAGE

Identify the tables that are used by referential constraints, unique constraints, check constraints, and assertions defined in this catalog and owned by a given user or role.

**Table 9-172** Column information

| Column name        | Data type    | Description                                                                   |
|--------------------|--------------|-------------------------------------------------------------------------------|
| TABLE_CATALOG      | VARCHAR(128) | catalog name of the table that participates in the constraint being described |
| TABLE_OWNER        | VARCHAR(128) | owner name of the table that participates in the constraint being described   |
| TABLE_SCHEMA       | VARCHAR(128) | schema name of the table that participates in the constraint being described  |
| TABLE_NAME         | VARCHAR(128) | table name that participates in the constraint being described                |
| CONSTRAINT_CATALOG | VARCHAR(128) | catalog name of the constraint                                                |
| CONSTRAINT_OWNER   | VARCHAR(128) | owner name of the constraint                                                  |
| CONSTRAINT_SCHEMA  | VARCHAR(128) | schema name of the constraint                                                 |
| CONSTRAINT_NAME    | VARCHAR(128) | constraint name                                                               |

## INFORMATION\_SCHEMA\_CATALOG\_NAME

Identify the catalog that contains the Information Schema

**Table 9-173** Column information

| Column name  | Data type    | Description                                                  |
|--------------|--------------|--------------------------------------------------------------|
| CATALOG_NAME | VARCHAR(128) | the name of catalog in which this Information Schema resides |

## KEY\_COLUMN\_USAGE

Identify the columns defined in this catalog that are constrained as keys and that are accessible by a given user or role.

**Table 9-174** Column information

| Column name                   | Data type    | Description                                                                                                                                                                                                                                                          |
|-------------------------------|--------------|----------------------------------------------------------------------------------------------------------------------------------------------------------------------------------------------------------------------------------------------------------------------|
| CONSTRAINT_CATALOG            | VARCHAR(128) | catalog name of the constraint                                                                                                                                                                                                                                       |
| CONSTRAINT_OWNER              | VARCHAR(128) | owner name of the constraint                                                                                                                                                                                                                                         |
| CONSTRAINT_SCHEMA             | VARCHAR(128) | schema name of the constraint                                                                                                                                                                                                                                        |
| CONSTRAINT_NAME               | VARCHAR(128) | constraint name                                                                                                                                                                                                                                                      |
| TABLE_CATALOG                 | VARCHAR(128) | catalog name of the column that participates in the constraint being described                                                                                                                                                                                       |
| TABLE_OWNER                   | VARCHAR(128) | owner name of the column that participates in the constraint being described                                                                                                                                                                                         |
| TABLE_SCHEMA                  | VARCHAR(128) | schema name of the column that participates in the constraint being described                                                                                                                                                                                        |
| TABLE_NAME                    | VARCHAR(128) | table name of the column that participates in the constraint being described                                                                                                                                                                                         |
| COLUMN_NAME                   | VARCHAR(128) | column name that participates in the constraint being described                                                                                                                                                                                                      |
| ORDINAL_POSITION              | NUMBER       | the ordinal position of the specific column in the constraint being described. If the constraint described is a key of cardinality 1 (one), then the value of ORDINAL_POSITION is always 1 (one).                                                                    |
| POSITION_IN_UNIQUE_CONSTRAINT | NUMBER       | If the constraint being described is a foreign key constraint, then the value of POSITION_IN_UNIQUE_CONSTRAINT is the ordinal position of the referenced column corresponding to the referencing column being described, in the corresponding unique key constraint. |

## MODULES

Identify the SQL-server modules in this catalog that are accessible to a given user or role.

**Table 9-175** Column information

| Column name                   | Data type                      | Description                                                 |
|-------------------------------|--------------------------------|-------------------------------------------------------------|
| MODULE_CATALOG                | VARCHAR(128)                   | catalog name of the SQL-server module                       |
| MODULE_OWNER                  | VARCHAR(128)                   | owner name of the SQL-server module                         |
| MODULE_SCHEMA                 | VARCHAR(128)                   | schema name of the SQL-server module                        |
| MODULE_NAME                   | VARCHAR(128)                   | name of the SQL-server module                               |
| DEFAULT_CHARACTER_SET_CATALOG | VARCHAR(128)                   | default character set catalog name of the SQL-server module |
| DEFAULT_CHARACTER_SET_SCHEMA  | VARCHAR(128)                   | default character set schema name of the SQL-server module  |
| DEFAULT_CHARACTER_SET         | VARCHAR(128)                   | default character set name of the SQL-server module         |
| DEFAULT_SCHEMA_CATALOG        | VARCHAR(128)                   | catalog name of default schema of SQL-server module         |
| DEFAULT_SCHEMA_NAME           | VARCHAR(128)                   | default schema name of the SQL-server module                |
| MODULE_DEFINITION             | LONG VARCHAR                   | definition of the SQL-server module                         |
| MODULE_AUTHORIZATION          | VARCHAR(32)                    | authorization of the SQL-server module(DEFINER/INVOKER)     |
| SQL_PATH                      | VARCHAR(1024)                  | described SQL PATH when the SQL-server module is defined    |
| CREATED                       | TIMESTAMP(2) WITHOUT TIME ZONE | creation time of the SQL-server module                      |
| LAST_ALTERED                  | TIMESTAMP(2) WITHOUT TIME ZONE | most lately altered time of the SQL-server module           |

## MODULE\_BODY

Identify the SQL-server module bodies in this catalog that are accessible to a given user or role.

**Table 9-176** Column information

| Column name       | Data type                          | Description                                            |
|-------------------|------------------------------------|--------------------------------------------------------|
| MODULE_CATALOG    | VARCHAR(128)                       | catalog name of the SQL-server module                  |
| MODULE_OWNER      | VARCHAR(128)                       | owner name of the SQL-server module'                   |
| MODULE_SCHEMA     | VARCHAR(128)                       | schema name of the SQL-server module                   |
| MODULE_NAME       | VARCHAR(128)                       | name of the SQL-server module                          |
| MODULE_DEFINITION | LONG VARCHAR                       | definition of the SQL-server module body               |
| CREATED           | TIMESTAMP(2) WITH<br>OUT TIME ZONE | creation time of the SQL-server module body            |
| LAST_ALTERED      | TIMESTAMP(2) WITH<br>OUT TIME ZONE | most lately altered time of the SQL-server module body |

## MODULE\_BODY\_MODULE\_USAGE

Identify the SQL-server modules owned by a given user or role on which SQL-server module bodies defined in this catalog are dependent.

**Table 9-177** Column information

| Column name        | Data type    | Description                                                                                         |
|--------------------|--------------|-----------------------------------------------------------------------------------------------------|
| MODULE_CATALOG     | VARCHAR(128) | catalog name of the SQL-server module                                                               |
| MODULE_OWNER       | VARCHAR(128) | owner name of the SQL-server module                                                                 |
| MODULE_SCHEMA      | VARCHAR(128) | schema name of the SQL-server module                                                                |
| MODULE_NAME        | VARCHAR(128) | name of the SQL-server module                                                                       |
| REF_MODULE_CATALOG | VARCHAR(128) | catalog name of the SQL-server module of contained in definition text of the SQL-server module body |
| REF_MODULE_OWNER   | VARCHAR(128) | owner name of the SQL-server module of contained in definition text of the SQL-server module body   |
| REF_MODULE_SCHEMA  | VARCHAR(128) | schema name of the SQL-server module of contained in definition text of the SQL-server module body  |
| REF_MODULE_NAME    | VARCHAR(128) | SQL-server module name of contained in definition text of the SQL-server module body                |

## MODULE\_BODY\_ROUTINE\_USAGE

Identify the SQL-invoked routines owned by a given user or role on which SQL-server module bodies defined in this catalog are dependent.

**Table 9-178** Column information

| Column name     | Data type    | Description                                                                                           |
|-----------------|--------------|-------------------------------------------------------------------------------------------------------|
| MODULE_CATALOG  | VARCHAR(128) | catalog name of the SQL-server module                                                                 |
| MODULE_OWNER    | VARCHAR(128) | owner name of the SQL-server module                                                                   |
| MODULE_SCHEMA   | VARCHAR(128) | schema name of the SQL-server module                                                                  |
| MODULE_NAME     | VARCHAR(128) | name of the SQL-server module                                                                         |
| ROUTINE_CATALOG | VARCHAR(128) | catalog name of the SQL-invoked routine of contained in definition text of the SQL-server module body |
| ROUTINE_OWNER   | VARCHAR(128) | owner name of the SQL-invoked routine of contained in definition text of the SQL-server module body   |
| ROUTINE_SCHEMA  | VARCHAR(128) | schema name of the SQL-invoked routine of contained in definition text of the SQL-server module body  |
| ROUTINE_NAME    | VARCHAR(128) | SQL-invoked routine name of contained in definition text of the SQL-server module body                |



## MODULE\_BODY\_SEQUENCE\_USAGE

Identify the sequences owned by a given user or role on which SQL-server module bodies defined in this catalog are dependent.

**Table 9-179** Column information

| Column name      | Data type    | Description                                                                                |
|------------------|--------------|--------------------------------------------------------------------------------------------|
| MODULE_CATALOG   | VARCHAR(128) | catalog name of the SQL-server module                                                      |
| MODULE_OWNER     | VARCHAR(128) | owner name of the SQL-server module                                                        |
| MODULE_SCHEMA    | VARCHAR(128) | schema name of the SQL-server module                                                       |
| MODULE_NAME      | VARCHAR(128) | name of the SQL-server module                                                              |
| SEQUENCE_CATALOG | VARCHAR(128) | catalog name of the sequence of contained in definition text of the SQL-server module body |
| SEQUENCE_OWNER   | VARCHAR(128) | owner name of the sequence of contained in definition text of the SQL-server module body   |
| SEQUENCE_SCHEMA  | VARCHAR(128) | schema name of the sequence of contained in definition text of the SQL-server module body  |
| SEQUENCE_NAME    | VARCHAR(128) | sequence name of contained in definition text of the SQL-server module body                |

## MODULE\_BODY\_TABLE\_USAGE

Identify the tables owned by a given user or role on which SQL-server module bodies defined in this catalog are dependent.

**Table 9-180** Column information

| Column name    | Data type    | Description                                                                             |
|----------------|--------------|-----------------------------------------------------------------------------------------|
| MODULE_CATALOG | VARCHAR(128) | catalog name of the SQL-server module                                                   |
| MODULE_OWNER   | VARCHAR(128) | owner name of the SQL-server module                                                     |
| MODULE_SCHEMA  | VARCHAR(128) | schema name of the SQL-server module                                                    |
| MODULE_NAME    | VARCHAR(128) | name of the SQL-server module                                                           |
| TABLE_CATALOG  | VARCHAR(128) | catalog name of the table of contained in definition text of the SQL-server module body |
| TABLE_OWNER    | VARCHAR(128) | owner name of the table of contained in definition text of the SQL-server module body   |
| TABLE_SCHEMA   | VARCHAR(128) | schema name of the table of contained in definition text of the SQL-server module body  |
| TABLE_NAME     | VARCHAR(128) | table name of contained in definition text of the SQL-server module body                |

## MODULE\_MODULE\_USAGE

Identify the SQL-server modules owned by a given user or role on which SQL-server modules defined in this catalog are dependent.

**Table 9-181** Column information

| Column name        | Data type    | Description                                                                                    |
|--------------------|--------------|------------------------------------------------------------------------------------------------|
| MODULE_CATALOG     | VARCHAR(128) | catalog name of the SQL-server module                                                          |
| MODULE_OWNER       | VARCHAR(128) | owner name of the SQL-server module                                                            |
| MODULE_SCHEMA      | VARCHAR(128) | schema name of the SQL-server module                                                           |
| MODULE_NAME        | VARCHAR(128) | name of the SQL-server module                                                                  |
| REF_MODULE_CATALOG | VARCHAR(128) | catalog name of the SQL-server module of contained in definition text of the SQL-server module |
| REF_MODULE_OWNER   | VARCHAR(128) | owner name of the SQL-server module of contained in definition text of the SQL-server module   |
| REF_MODULE_SCHEMA  | VARCHAR(128) | schema name of the SQL-server module of contained in definition text of the SQL-server module  |
| REF_MODULE_NAME    | VARCHAR(128) | SQL-server module name of contained in definition text of the SQL-server module                |

## MODULE\_PRIVILEGES

Identify the privileges on SQL-server modules defined in this catalog that are available to or granted by a given user or role.

**Table 9-182** Column information

| Column name    | Data type    | Description                                                                                                                                  |
|----------------|--------------|----------------------------------------------------------------------------------------------------------------------------------------------|
| GRANTOR        | VARCHAR(128) | authorization name of the user who granted SQL-server module privileges                                                                      |
| GRANTEE        | VARCHAR(128) | authorization name of some user or role, or PUBLIC to indicate all users, to whom the SQL-server module privilege being described is granted |
| MODULE_CATALOG | VARCHAR(128) | catalog name of the SQL-server module on which the privilege being described was granted                                                     |
| MODULE_OWNER   | VARCHAR(128) | owner name of the the SQL-server module on which the privilege being described was granted                                                   |
| MODULE_SCHEMA  | VARCHAR(128) | schema name of the the SQL-server module on which the privilege being described was granted                                                  |
| MODULE_NAME    | VARCHAR(128) | name of the the SQL-server module on which the privilege being described was granted                                                         |
| PRIVILEGE_TYPE | VARCHAR(32)  | the value is in ( EXECUTE )                                                                                                                  |
| IS_GRANTABLE   | BOOLEAN      | is grantable                                                                                                                                 |

## MODULE\_ROUTINE\_USAGE

Identify the SQL-invoked routines owned by a given user or role on which SQL-server modules defined in this catalog are dependent.

**Table 9-183** Column information

| Column name     | Data type    | Description                                                                                      |
|-----------------|--------------|--------------------------------------------------------------------------------------------------|
| MODULE_CATALOG  | VARCHAR(128) | catalog name of the SQL-server module                                                            |
| MODULE_OWNER    | VARCHAR(128) | owner name of the SQL-server module                                                              |
| MODULE_SCHEMA   | VARCHAR(128) | schema name of the SQL-server module                                                             |
| MODULE_NAME     | VARCHAR(128) | name of the SQL-server module                                                                    |
| ROUTINE_CATALOG | VARCHAR(128) | catalog name of the SQL-invoked routine of contained in definition text of the SQL-server module |
| ROUTINE_OWNER   | VARCHAR(128) | owner name of the SQL-invoked routine of contained in definition text of the SQL-server module   |
| ROUTINE_SCHEMA  | VARCHAR(128) | schema name of the SQL-invoked routine of contained in definition text of the SQL-server module  |
| ROUTINE_NAME    | VARCHAR(128) | SQL-invoked routine name of contained in definition text of the SQL-server module                |

## MODULE\_SEQUENCE\_USAGE

Identify the sequences owned by a given user or role on which SQL-server modules defined in this catalog are dependent.

**Table 9-184** Column information

| Column name      | Data type    | Description                                                                           |
|------------------|--------------|---------------------------------------------------------------------------------------|
| MODULE_CATALOG   | VARCHAR(128) | catalog name of the SQL-server module                                                 |
| MODULE_OWNER     | VARCHAR(128) | owner name of the SQL-server module                                                   |
| MODULE_SCHEMA    | VARCHAR(128) | schema name of the SQL-server module                                                  |
| MODULE_NAME      | VARCHAR(128) | name of the SQL-server module                                                         |
| SEQUENCE_CATALOG | VARCHAR(128) | catalog name of the sequence of contained in definition text of the SQL-server module |
| SEQUENCE_OWNER   | VARCHAR(128) | owner name of the sequence of contained in definition text of the SQL-server module   |
| SEQUENCE_SCHEMA  | VARCHAR(128) | schema name of the sequence of contained in definition text of the SQL-server module  |
| SEQUENCE_NAME    | VARCHAR(128) | sequence name of contained in definition text of the SQL-server module                |

## MODULE\_TABLE\_USAGE

Identify the tables owned by a given user or role on which SQL-server modules defined in this catalog are dependent.

**Table 9-185** Column information

| Column name    | Data type    | Description                                                                        |
|----------------|--------------|------------------------------------------------------------------------------------|
| MODULE_CATALOG | VARCHAR(128) | catalog name of the SQL-server module                                              |
| MODULE_OWNER   | VARCHAR(128) | owner name of the SQL-server module                                                |
| MODULE_SCHEMA  | VARCHAR(128) | schema name of the SQL-server module                                               |
| MODULE_NAME    | VARCHAR(128) | name of the SQL-server module                                                      |
| TABLE_CATALOG  | VARCHAR(128) | catalog name of the table of contained in definition text of the SQL-server module |
| TABLE_OWNER    | VARCHAR(128) | owner name of the table of contained in definition text of the SQL-server module   |
| TABLE_SCHEMA   | VARCHAR(128) | schema name of the table of contained in definition text of the SQL-server module  |
| TABLE_NAME     | VARCHAR(128) | table name of contained in definition text of the SQL-server module                |

## PARAMETERS

Identify the SQL parameters of SQL-invoked routines defined in this catalog that are accessible to a given user or role.

**Table 9-186** Column information

| Column name               | Data type    | Description                                                                                                   |
|---------------------------|--------------|---------------------------------------------------------------------------------------------------------------|
| SPECIFIC_CATALOG          | VARCHAR(128) | catalog name of the specific name of the SQL- invoked routine that contains the SQL parameter being described |
| SPECIFIC_OWNER            | VARCHAR(128) | owner name of the specific name of the SQL- invoked routine that contains the SQL parameter being described   |
| SPECIFIC_SCHEMA           | VARCHAR(128) | schema name of the specific name of the SQL- invoked routine that contains the SQL parameter being described  |
| SPECIFIC_NAME             | VARCHAR(128) | specific name of the SQL- invoked routine that contains the SQL parameter being described                     |
| ORDINAL_POSITION          | NUMBER       | ordinal position of the SQL- invoked routine that contains the SQL parameter being described                  |
| PARAMETER_MODE            | VARCHAR(32)  | parameter mode of the SQL parameter being described                                                           |
| IS_RESULT                 | BOOLEAN      | the parameter is RESULT parameter of type-preserving function                                                 |
| AS_LOCATOR                | BOOLEAN      | the parameter is passed as locator                                                                            |
| PARAMETER_NAME            | VARCHAR(128) | name of the SQL parameter being described                                                                     |
| FROM_SQL_SPECIFIC_CATALOG | VARCHAR(128) | specific catalog name of the from-sql routine for the input parameter being described                         |
| FROM_SQL_SPECIFIC_SCHEMA  | VARCHAR(128) | specific schema name of the from-sql routine for the input parameter being described                          |
| FROM_SQL_SPECIFIC_NAME    | VARCHAR(128) | specific name of the from-sql routine for the input parameter being described                                 |
| TO_SQL_SPECIFIC_CATALOG   | VARCHAR(128) | specific catalog name of the to-sql routine for the input parameter being described                           |
| TO_SQL_SPECIFIC_SCHEMA    | VARCHAR(128) | specific schema name of the to-sql routine for the input parameter being described                            |
| TO_SQL_SPECIFIC_NAME      | VARCHAR(128) | specific name of the to-sql routine for the input parameter being described                                   |
| DATA_TYPE                 | VARCHAR(128) | data type of the SQL parameter being described                                                                |
| CHARACTER_MAXIMUM_LENGTH  | NUMBER       | maximum length of the SQL parameter being described                                                           |
|                           |              | maximum length in octets of the SQL parameter being described                                                 |



| Column name             | Data type    | Description                                                                                |
|-------------------------|--------------|--------------------------------------------------------------------------------------------|
| CHARACTER_OCTET_LENGTH  | NUMBER       | g described                                                                                |
| CHARACTER_SET_CATALOG   | VARCHAR(128) | character set catalog name of the data type of the SQL parameter being described           |
| CHARACTER_SET_SCHEMA    | VARCHAR(128) | character set schema name of the data type of the SQL parameter being described            |
| CHARACTER_SET_NAME      | VARCHAR(128) | character set name of the data type of the SQL parameter being described                   |
| COLLATION_CATALOG       | VARCHAR(128) | collation catalog name of the data type of the SQL parameter being described               |
| COLLATION_SCHEMA        | VARCHAR(128) | collation schema name of the data type of the SQL parameter being described                |
| COLLATION_NAME          | VARCHAR(128) | collation name of the data type of the SQL parameter being described                       |
| NUMERIC_PRECISION       | NUMBER       | precision of the data type of the SQL parameter being described                            |
| NUMERIC_PRECISION_RADIX | NUMBER       | precision radix of the data type of the SQL parameter being described                      |
| NUMERIC_SCALE           | NUMBER       | scale of the data type of the SQL parameter being described                                |
| DATETIME_PRECISION      | NUMBER       | fractional second precisions of the data type of the SQL parameter being described         |
| INTERVAL_TYPE           | VARCHAR(32)  | interval qualifier of the data type of the SQL parameter being described                   |
| INTERVAL_PRECISION      | NUMBER       | interval precision of the data type of the SQL parameter being described                   |
| UDT_CATALOG             | VARCHAR(128) | catalog name of UDT of the data type of the SQL parameter being described                  |
| UDT_SCHEMA              | VARCHAR(128) | schema name of UDT of the data type of the SQL parameter being described                   |
| UDT_NAME                | VARCHAR(128) | name of UDT of the data type of the SQL parameter being described                          |
| SCOPE_CATALOG           | VARCHAR(128) | catalog name of referenceable tables of the data type of the SQL parameter being described |
| SCOPE_SCHEMA            | VARCHAR(128) | schema name of referenceable tables of the data type of the SQL parameter being described  |
| SCOPE_NAME              | VARCHAR(128) | name of referenceable tables of the data type of the SQL parameter being described         |
| MAXIMUM_CARDINALITY     | NUMBER       | maximum cardinality of the data type of the SQL parameter being described                  |
| DTD_IDENTIFIER          | NUMBER       | dtd identifier of the data type of the SQL parameter being described                       |
|                         |              | declared data type of the SQL parameter being described                                    |

| Column name                | Data type    | Description                                                          |
|----------------------------|--------------|----------------------------------------------------------------------|
| DECLARED_DATA_TYPE         | VARCHAR(128) | bed                                                                  |
| DECLARED_NUMERIC_PRECISION | NUMBER       | precision of declared data type of the SQL parameter being described |
| DECLARED_NUMERIC_SCALE     | NUMBER       | scale of declared data type of the SQL parameter being described     |
| PARAMETER_DEFAULT          | LONG VARCHAR | default value of the SQL parameter being described                   |

## REFERENTIAL\_CONSTRAINTS

Identify the referential constraints defined on tables in this catalog that are accessible to a given user or role.

**Table 9-187** Column information

| Column name                   | Data type    | Description                                                                                                              |
|-------------------------------|--------------|--------------------------------------------------------------------------------------------------------------------------|
| CONSTRAINT_CATALOG            | VARCHAR(128) | catalog name of the referential constraint                                                                               |
| CONSTRAINT_OWNER              | VARCHAR(128) | owner name who owns the referential constraint                                                                           |
| CONSTRAINT_SCHEMA             | VARCHAR(128) | schema name of the referential constraint being described                                                                |
| CONSTRAINT_NAME               | VARCHAR(128) | referential constraint name                                                                                              |
| CONSTRAINT_TABLE_NAME         | VARCHAR(128) | name of the table to which the referential constraint being described applies                                            |
| CONSTRAINT_COLUMN_NAME        | VARCHAR(128) | column name of the table to which the referential constraint being described applies                                     |
| ORDINAL_POSITION              | NUMBER       | the ordinal position of the specific column in the referential constraint being described.                               |
| UNIQUE_CONSTRAINT_CATALOG     | VARCHAR(128) | catalog name of the unique or primary key constraint applied to the referenced column list being described               |
| UNIQUE_CONSTRAINT_OWNER       | VARCHAR(128) | owner name of the unique or primary key constraint applied to the referenced column list being described                 |
| UNIQUE_CONSTRAINT_SCHEMA      | VARCHAR(128) | schema name of the unique or primary key constraint applied to the referenced column list being described                |
| UNIQUE_CONSTRAINT_NAME        | VARCHAR(128) | constraint name of the unique or primary key constraint applied to the referenced column list being described            |
| UNIQUE_CONSTRAINT_TABLE_NAME  | VARCHAR(128) | table name of the unique or primary key constraint applied to the referenced column list being described                 |
| UNIQUE_CONSTRAINT_COLUMN_NAME | VARCHAR(128) | column name of the unique or primary key constraint applied to the referenced column list being described                |
| IS_PRIMARY_KEY                | BOOLEAN      | whether the constraint applied to the referenced column list being described, is primary key or not                      |
| MATCH_OPTION                  | VARCHAR(32)  | the referential constraint that has a match option: the value in ( SIMPLE, PARTIAL, FULL )                               |
| UPDATE_RULE                   | VARCHAR(32)  | the referential constraint that has an update rule: the value in ( NO ACTION, RESTRICT, CASCADE, SET NULL, SET DEFAULT ) |
|                               |              | the referential constraint that has a delete rule: the value in ( NO ACTION, R                                           |

| Column name        | Data type   | Description                               |
|--------------------|-------------|-------------------------------------------|
| DELETE_RULE        | VARCHAR(32) | ESTRICT, CASCADE, SET NULL, SET DEFAULT ) |
| IS_DEFERRABLE      | BOOLEAN     | is a deferrable constraint                |
| INITIALLY_DEFERRED | BOOLEAN     | is an initially deferred constraint       |

## ROUTINES

Identify the SQL-invoked routines in this catalog that are accessible to a given user or role.

**Table 9-188** Column information

| Column name              | Data type    | Description                                                                               |
|--------------------------|--------------|-------------------------------------------------------------------------------------------|
| SPECIFIC_CATALOG         | VARCHAR(128) | specific catalog name of the routine                                                      |
| SPECIFIC_OWNER           | VARCHAR(128) | specific owner name of the routine                                                        |
| SPECIFIC_SCHEMA          | VARCHAR(128) | specific schema name of the routine                                                       |
| SPECIFIC_NAME            | VARCHAR(128) | specific name of the routine                                                              |
| ROUTINE_CATALOG          | VARCHAR(128) | catalog name of the routine                                                               |
| ROUTINE_OWNER            | VARCHAR(128) | owner name of the routine                                                                 |
| ROUTINE_SCHEMA           | VARCHAR(128) | schema name of the routine                                                                |
| ROUTINE_NAME             | VARCHAR(128) | null                                                                                      |
| ROUTINE_TYPE             | VARCHAR(128) | name of the routine                                                                       |
| MODULE_CATALOG           | VARCHAR(128) | module name of the routine                                                                |
| MODULE_SCHEMA            | VARCHAR(128) | schema name of the module in which the routine is defined                                 |
| MODULE_NAME              | VARCHAR(128) | name of the module in which the routine is defined                                        |
| UDT_CATALOG              | VARCHAR(128) | catalog name of the user-defined data type which defined the routine as a method function |
| UDT_SCHEMA               | VARCHAR(128) | schema name of the user-defined data type which defined the routine as a method function  |
| UDT_NAME                 | VARCHAR(128) | name of the user-defined data type which defined the routine as a method function         |
| DATA_TYPE                | VARCHAR(128) | data type the routine returns                                                             |
| CHARACTER_MAXIMUM_LENGTH | NUMBER       | maximum character length of data type the routine returns                                 |
| CHARACTER_OCTET_LENGTH   | NUMBER       | maximum character length in octets of data type the routine returns                       |
| CHARACTER_SET_CATALOG    | VARCHAR(128) | character set catalog name of data type the routine returns                               |
| CHARACTER_SET_SCHEMA     | VARCHAR(128) | character set schema name of data type the routine returns                                |
| CHARACTER_SET_NAME       | VARCHAR(128) | character set name of data type the routine returns                                       |
| COLLATION_CATALOG        | VARCHAR(128) | collation catalog name of data type the routine returns                                   |
| COLLATION_SCHEMA         | VARCHAR(128) | collation schema name of data type the routine returns                                    |
| COLLATION_NAME           | VARCHAR(128) | collation name of data type the routine returns                                           |
| NUMERIC_PRECISION        | NUMBER       | precision of data type the routine returns                                                |
| NUMERIC_PRECISION_RADIX  | NUMBER       | precision radix of data type the routine returns                                          |
| NUMERIC_SCALE            | NUMBER       | scale of data type the routine returns                                                    |

| Column name             | Data type                      | Description                                                                            |
|-------------------------|--------------------------------|----------------------------------------------------------------------------------------|
| DATETIME_PRECISION      | NUMBER                         | fractional seconds precision of data type the routine returns                          |
| INTERVAL_TYPE           | VARCHAR(32)                    | interval qualifier for data type the routine returns                                   |
| INTERVAL_PRECISION      | NUMBER                         | interval leading field precision of data type the routine returns                      |
| TYPE_UDT_CATALOG        | VARCHAR(128)                   | catalog name of the user-defined data type, which is the data type the routine returns |
| TYPE_UDT_SCHEMA         | VARCHAR(128)                   | schema name of the user-defined data type, which is the data type the routine returns  |
| TYPE_UDT_NAME           | VARCHAR(128)                   | name of the user-defined data type, which is the data type the routine returns         |
| SCOPE_CATALOG           | VARCHAR(128)                   | catalog name of referenceable table                                                    |
| SCOPE_SCHEMA            | VARCHAR(128)                   | schema name of referenceable table                                                     |
| SCOPE_NAME              | VARCHAR(128)                   | name of referenceable table                                                            |
| MAXIMUM_CARDINALITY     | NUMBER                         | maximum cardinality of data type the routine returns                                   |
| DTD_IDENTIFIER          | NUMBER                         | dtd identifier of data type the routine returns                                        |
| ROUTINE_BODY            | VARCHAR(32)                    | type of the routine body                                                               |
| ROUTINE_DEFINITION      | LONG VARCHAR                   | catalog name of the routine                                                            |
| EXTERNAL_NAME           | VARCHAR(128)                   | external name of the external routine                                                  |
| EXTERNAL_LANGUAGE       | VARCHAR(32)                    | language of the external routine                                                       |
| PARAMETER_STYLE         | VARCHAR(32)                    | SQL parameter passing style of the external routine                                    |
| IS_DETERMINISTIC        | BOOLEAN                        | the routine is deterministic or not                                                    |
| SQL_DATA_ACCESS         | VARCHAR(32)                    | routine possibly contains SQL or access data                                           |
| IS_NULL_CALL            | BOOLEAN                        | routine returns NULL if any of parameter values are NULL                               |
| SQL_PATH                | VARCHAR(1024)                  | described SQL PATH when the routine is defined                                         |
| SCHEMA_LEVEL_ROUTINE    | BOOLEAN                        | the routine is schema-level routine                                                    |
| MAX_DYNAMIC_RESULT_SETS | NUMBER                         | max result set count of the routine                                                    |
| IS_USER_DEFINED_CAST    | BOOLEAN                        | the routine is a function that is a user-defined cast function                         |
| IS_IMPLICITLY_INVOCABLE | BOOLEAN                        | the user-defined cast function is implicitly invocable                                 |
| SECURITY_TYPE           | VARCHAR(32)                    | security type of the routine(DEFINER/INVOKER)                                          |
| TO_SQL_SPECIFIC_CATALOG | VARCHAR(128)                   | catalog name of the to-sql routine of the result type of routine                       |
| TO_SQL_SPECIFIC_SCHEMA  | VARCHAR(128)                   | schema name of the to-sql routine of the result type of routine                        |
| TO_SQL_SPECIFIC_NAME    | VARCHAR(128)                   | name of the to-sql routine of the result type of routine                               |
| AS_LOCATOR              | BOOLEAN                        | return value of the routine is passed as locator                                       |
| CREATED                 | TIMESTAMP(2) WITHOUT TIME ZONE | creation time of the routine                                                           |
| LAST_ALTERED            | TIMESTAMP(2) WITHOUT TIME ZONE | most lately altered time of the routine                                                |
| NEW_SAVEPOINT_LEVEL     | BOOLEAN                        | specify new savepoint level or not                                                     |

| Column name                    | Data type    | Description                                                                                                        |
|--------------------------------|--------------|--------------------------------------------------------------------------------------------------------------------|
| IS_UDT_DEPENDENT               | BOOLEAN      | routine is dependent                                                                                               |
| RESULT_CAST_FROM_DATA_TYPE     | VARCHAR(128) | data type which is specified in result cast clause of the routine definition                                       |
| RESULT_CAST_AS_LOCATOR         | BOOLEAN      | locator indication which is specified in result cast clause of the routine definition                              |
| RESULT_CAST_CHAR_MAX_LENGTH    | NUMBER       | maximum character length of data type which is specified in result cast clause of the routine definition           |
| RESULT_CAST_CHAR_OCTET_LENGTH  | NUMBER       | maximum character length in octets of data type which is specified in result cast clause of the routine definition |
| RESULT_CAST_CHAR_SET_CATALOG   | VARCHAR(128) | character set catalog name of data type which is specified in result cast clause of the routine definition         |
| RESULT_CAST_CHAR_SET_SCHEMA    | VARCHAR(128) | character set schema name of data type which is specified in result cast clause of the routine definition          |
| RESULT_CAST_CHARACTER_SET_NAME | VARCHAR(128) | character set name of data type which is specified in result cast clause of the routine definition                 |
| RESULT_CAST_COLLATION_CATALOG  | VARCHAR(128) | collation catalog name of data type which is specified in result cast clause of the routine definition             |
| RESULT_CAST_COLLATION_SCHEMA   | VARCHAR(128) | collation schema name of data type which is specified in result cast clause of the routine definition              |
| RESULT_CAST_COLLATION_NAME     | VARCHAR(128) | collation name of data type which is specified in result cast clause of the routine definition                     |
| RESULT_CAST_NUMERIC_PRECISION  | NUMBER       | precision of data type which is specified in result cast clause of the routine definition                          |
| RESULT_CAST_NUMERIC_RADIX      | NUMBER       | precision radix of data type which is specified in result cast clause of the routine definition                    |
| RESULT_CAST_NUMERIC_SCALE      | NUMBER       | scale of data type which is specified in result cast clause of the routine definition                              |
| RESULT_CAST_DATETIME_PRECISION | NUMBER       | fractional seconds precision of data type which is specified in result cast clause of the routine definition       |
| RESULT_CAST_INTERVAL_TYPE      | VARCHAR(32)  | interval qualifier of data type which is specified in result cast clause of the routine definition                 |
| RESULT_CAST_INTERVAL_PRECISION | NUMBER       | interval precision of data type which is specified in result cast clause of the routine definition                 |
| RESULT_CAST_TYPE_UDT_CATALOG   | VARCHAR(128) | UDT catalog name of data type which is specified in result cast clause of the routine definition                   |
| RESULT_CAST_TYPE_UDT_SCHEMA    | VARCHAR(128) | UDT schema name of data type which is specified in result cast clause of the routine definition                    |
| RESULT_CAST_TYPE_UDT_NAME      | VARCHAR(128) | UDT name of data type which is specified in result cast clause of the routine definition                           |
| RESULT_CAST_SCOPE_CATALOG      | VARCHAR(128) | catalog name of referenceable table described in result cast clause of the routine definition                      |
| RESULT_CAST_SCOPE_SCHEMA       |              | schema name of referenceable table described in result cast cl                                                     |

| Column name                            | Data type    | Description                                                                                         |
|----------------------------------------|--------------|-----------------------------------------------------------------------------------------------------|
| EMA                                    | VARCHAR(128) | ause of the routine definition                                                                      |
| RESULT_CAST_SCOPE_NAME                 | VARCHAR(128) | name of referenceable table described in result cast clause of the routine definition               |
| RESULT_CAST_MAX_CARDINALITY            | NUMBER       | maximum cardinality of data type which is specified in result cast clause of the routine definition |
| RESULT_CAST_DTD_IDENTIFIER             | NUMBER       | dtd identifier of data type which is specified in result cast clause of the routine definition      |
| DECLARED_DATA_TYPE                     | VARCHAR(128) | declared data type of the routine returns                                                           |
| DECLARED_NUMERIC_PRECISION             | NUMBER       | declared data type precision of the routine returns                                                 |
| DECLARED_NUMERIC_SCALE                 | NUMBER       | declared data type scale of the routine returns                                                     |
| RESULT_CAST_FROM_DECLARED_DATA_TYPE    | VARCHAR(128) | declared data type which is specified in result cast clause of the routine definition               |
| RESULT_CAST_DECLARED_NUMERIC_PRECISION | NUMBER       | declared data type precision which is specified in result cast clause of the routine definition     |
| RESULT_CAST_DECLARED_NUMERIC_SCALE     | NUMBER       | declared data type scale which is specified in result cast clause of the routine definition         |



## ROUTINE\_MODULE\_USAGE

Identify the SQL-server modules owned by a given user or role on which SQL routines defined in this catalog are dependent.

**Table 9-189** Column information

| Column name      | Data type    | Description                                                                                   |
|------------------|--------------|-----------------------------------------------------------------------------------------------|
| SPECIFIC_CATALOG | VARCHAR(128) | specific catalog name of the routine                                                          |
| SPECIFIC_OWNER   | VARCHAR(128) | specific owner name of the routine                                                            |
| SPECIFIC_SCHEMA  | VARCHAR(128) | specific schema name of the routine                                                           |
| SPECIFIC_NAME    | VARCHAR(128) | specific name of the routine                                                                  |
| MODULE_CATALOG   | VARCHAR(128) | catalog name of the SQL-server module of contained in routine body of the SQL-invoked routine |
| MODULE_OWNER     | VARCHAR(128) | owner name of the SQL-server module of contained in routine body of the SQL-invoked routine   |
| MODULE_SCHEMA    | VARCHAR(128) | schema name of the SQL-server module of contained in routine body of the SQL-invoked routine  |
| MODULE_NAME      | VARCHAR(128) | SQL-server module name of contained in routine body of the SQL-invoked routine                |

## ROUTINE\_PRIVILEGES

Identify the privileges on SQL-invoked routines defined in this catalog that are available to or granted by a given user or role.

**Table 9-190** Column information

| Column name      | Data type    | Description                                                                                                                        |
|------------------|--------------|------------------------------------------------------------------------------------------------------------------------------------|
| GRANTOR          | VARCHAR(128) | authorization name of the user who granted routine privileges                                                                      |
| GRANTEE          | VARCHAR(128) | authorization name of some user or role, or PUBLIC to indicate all users, to whom the routine privilege being described is granted |
| SPECIFIC_CATALOG | VARCHAR(128) | specific catalog name of the SQL-invoked routine on which the privilege being described was granted                                |
| SPECIFIC_OWNER   | VARCHAR(128) | specific owner name of the the SQL-invoked routine on which the privilege being described was granted                              |
| SPECIFIC_SCHEMA  | VARCHAR(128) | specific schema name of the the SQL-invoked routine on which the privilege being described was granted                             |
| SPECIFIC_NAME    | VARCHAR(128) | specific name of the the SQL-invoked routine on which the privilege being described was granted                                    |
| ROUTINE_CATALOG  | VARCHAR(128) | routine catalog name of the SQL-invoked routine on which the privilege being described was granted                                 |
| ROUTINE_OWNER    | VARCHAR(128) | null                                                                                                                               |
| ROUTINE_SCHEMA   | VARCHAR(128) | routine schema name of the the SQL-invoked routine on which the privilege being described was granted                              |
| ROUTINE_NAME     | VARCHAR(128) | routine name of the the SQL-invoked routine on which the privilege being described was granted                                     |
| PRIVILEGE_TYPE   | VARCHAR(32)  | the value is in ( EXECUTE )                                                                                                        |
| IS_GRANTABLE     | BOOLEAN      | is grantable                                                                                                                       |

## ROUTINE\_ROUTINE\_USAGE

Identify each SQL-invoked routine owned by a given user or role on which an SQL routine defined in this catalog is dependent.

**Table 9-191** Column information

| Column name      | Data type    | Description                                                                            |
|------------------|--------------|----------------------------------------------------------------------------------------|
| SPECIFIC_CATALOG | VARCHAR(128) | specific catalog name of the routine                                                   |
| SPECIFIC_OWNER   | VARCHAR(128) | specific owner name of the routine                                                     |
| SPECIFIC_SCHEMA  | VARCHAR(128) | specific schema name of the routine                                                    |
| SPECIFIC_NAME    | VARCHAR(128) | specific name of the routine                                                           |
| ROUTINE_CATALOG  | VARCHAR(128) | routine catalog name of a routine contained in routine body of the SQL-invoked routine |
| ROUTINE_OWNER    | VARCHAR(128) | routine owner name of a routine contained in routine body of the SQL-invoked routine   |
| ROUTINE_SCHEMA   | VARCHAR(128) | routine schema name of a routine contained in routine body of the SQL-invoked routine  |
| ROUTINE_NAME     | VARCHAR(128) | routine name of a routine contained in routine body of the SQL-invoked routine         |

## ROUTINE\_SEQUENCE\_USAGE

Identify each external sequence generator owned by a given user or role on which some SQL routine defined in this catalog is dependent.

**Table 9-192** Column information

| Column name      | Data type    | Description                                                                          |
|------------------|--------------|--------------------------------------------------------------------------------------|
| SPECIFIC_CATALOG | VARCHAR(128) | specific catalog name of the routine                                                 |
| SPECIFIC_OWNER   | VARCHAR(128) | specific owner name of the routine                                                   |
| SPECIFIC_SCHEMA  | VARCHAR(128) | specific schema name of the routine                                                  |
| SPECIFIC_NAME    | VARCHAR(128) | specific name of the routine                                                         |
| SEQUENCE_CATALOG | VARCHAR(128) | catalog name of the sequence of contained in routine body of the SQL-invoked routine |
| SEQUENCE_OWNER   | VARCHAR(128) | owner name of the sequence of contained in routine body of the SQL-invoked routine   |
| SEQUENCE_SCHEMA  | VARCHAR(128) | schema name of the sequence of contained in routine body of the SQL-invoked routine  |
| SEQUENCE_NAME    | VARCHAR(128) | sequence name of contained in routine body of the SQL-invoked routine                |

## ROUTINE\_TABLE\_USAGE

Identify the tables owned by a given user or role on which SQL routines defined in this catalog are dependent.

**Table 9-193** Column information

| Column name      | Data type    | Description                                                                       |
|------------------|--------------|-----------------------------------------------------------------------------------|
| SPECIFIC_CATALOG | VARCHAR(128) | specific catalog name of the routine                                              |
| SPECIFIC_OWNER   | VARCHAR(128) | specific owner name of the routine                                                |
| SPECIFIC_SCHEMA  | VARCHAR(128) | specific schema name of the routine                                               |
| SPECIFIC_NAME    | VARCHAR(128) | specific name of the routine                                                      |
| TABLE_CATALOG    | VARCHAR(128) | catalog name of the table of contained in routine body of the SQL-invoked routine |
| TABLE_OWNER      | VARCHAR(128) | owner name of the table of contained in routine body of the SQL-invoked routine   |
| TABLE_SCHEMA     | VARCHAR(128) | schema name of the table of contained in routine body of the SQL-invoked routine  |
| TABLE_NAME       | VARCHAR(128) | table name of contained in routine body of the SQL-invoked routine                |

## SCHEMATA

Identify the schemata in a catalog that are owned by given user or accessible to given user or role.

**Table 9-194** Column information

| Column name                   | Data type                      | Description                                                                             |
|-------------------------------|--------------------------------|-----------------------------------------------------------------------------------------|
| CATALOG_NAME                  | VARCHAR(128)                   | catalog name of the schema                                                              |
| SCHEMA_NAME                   | VARCHAR(128)                   | schema name                                                                             |
| SCHEMA_OWNER                  | VARCHAR(128)                   | authorization name who owns the schema                                                  |
| DEFAULT_CHARACTER_SET_CATALOG | VARCHAR(128)                   | catalog name of the default character set for columns and domains in the schemata       |
| DEFAULT_CHARACTER_SET_SCHEMA  | VARCHAR(128)                   | schema name of the default character set for columns and domains in the schemata        |
| DEFAULT_CHARACTER_SET_NAME    | VARCHAR(128)                   | character set name of the default character set for columns and domains in the schemata |
| SQL_PATH                      | VARCHAR(1024)                  | character representation of schema path specification                                   |
| CREATED_TIME                  | TIMESTAMP(2) WITHOUT TIME ZONE | created time of the schema                                                              |
| MODIFIED_TIME                 | TIMESTAMP(2) WITHOUT TIME ZONE | last modified time of the schema                                                        |
| COMMENTS                      | VARCHAR(1024)                  | comments of the schema                                                                  |

# SEQUENCES

Identify the external sequence generators defined in this catalog that are accesible to a given user or role.

**Table 9-195** Column information

| Column name                | Data type                      | Description                                                       |
|----------------------------|--------------------------------|-------------------------------------------------------------------|
| SEQUENCE_CATALOG           | VARCHAR(128)                   | catalog name of the sequence                                      |
| SEQUENCE_OWNER             | VARCHAR(128)                   | owner name of the sequence                                        |
| SEQUENCE_SCHEMA            | VARCHAR(128)                   | schema name of the sequence                                       |
| SEQUENCE_NAME              | VARCHAR(128)                   | sequence name                                                     |
| DATA_TYPE                  | VARCHAR(128)                   | the standard name of the data type                                |
| NUMERIC_PRECISION          | NUMBER                         | the numeric precision of the numerical data type                  |
| NUMERIC_PRECISION_RADIX    | NUMBER                         | the radix ( 2 or 10 ) of the precision of the numerical data type |
| NUMERIC_SCALE              | NUMBER                         | the numeric scale of the exact numerical data type                |
| START_VALUE                | NUMBER                         | the start value of the sequence generator                         |
| MINIMUM_VALUE              | NUMBER                         | the minimum value of the sequence generator                       |
| MAXIMUM_VALUE              | NUMBER                         | the maximum value of the sequence generator                       |
| INCREMENT                  | NUMBER                         | the increment of the sequence generator                           |
| CYCLE_OPTION               | BOOLEAN                        | cycle option                                                      |
| CACHE_SIZE                 | NATIVE_INTEGER                 | number of sequence numbers to cache                               |
| DECLARED_DATA_TYPE         | VARCHAR(128)                   | the data type name that a user declared                           |
| DECLARED_NUMERIC_PRECISION | NUMBER                         | the precision value that a user declared                          |
| DECLARED_NUMERIC_SCALE     | NUMBER                         | the scale value that a user declared                              |
| CREATED_TIME               | TIMESTAMP(2) WITHOUT TIME ZONE | created time of the sequence generator                            |
| MODIFIED_TIME              | TIMESTAMP(2) WITHOUT TIME ZONE | last modified time of the sequence generator                      |
| COMMENTS                   | VARCHAR(1024)                  | comments of the sequence generator                                |

## SQL\_FEATURES

List the features and subfeatures of this ISO/IEC 9075 standard, and indicate which of these the SQL-implementation supports.

**Table 9-196** Column information

| Column name      | Data type     | Description                                                                                                                                                                                                                                                           |
|------------------|---------------|-----------------------------------------------------------------------------------------------------------------------------------------------------------------------------------------------------------------------------------------------------------------------|
| FEATURE_ID       | VARCHAR(32)   | identifier string of the conformance element                                                                                                                                                                                                                          |
| FEATURE_NAME     | VARCHAR(1024) | descriptive name of the conformance element                                                                                                                                                                                                                           |
| SUB_FEATURE_ID   | VARCHAR(32)   | identifier string of the subfeature, or a single space if not a subfeature                                                                                                                                                                                            |
| SUB_FEATURE_NAME | VARCHAR(1024) | descriptive name of the subfeature, or a single space if not a subfeature                                                                                                                                                                                             |
| IS_SUPPORTED     | BOOLEAN       | TRUE if an SQL-implementation fully supports that conformance element described when SQL-data in the identified catalog is accessed through that implementation, FALSE if not                                                                                         |
| IS_VERIFIED_BY   | VARCHAR(1024) | If full support for the conformance element described has been verified by testing, then the IS_VERIFIED_BY column shall contain information identifying the conformance test used to verify the conformance claim; otherwise, IS_VERIFIED_BY shall be the null value |
| COMMENTS         | VARCHAR(1024) | possibly a comment pertaining to the conformance element                                                                                                                                                                                                              |



## SQL\_IMPLEMENTATION\_INFO

List the SQL-implementation information items defined in this ISO/IEC 9075 standard and, for each of these, indicate the value supported by the SQL-implementation.

**Table 9-197** Column information

| Column name              | Data type      | Description                                                                                                   |
|--------------------------|----------------|---------------------------------------------------------------------------------------------------------------|
| IMPLEMENTATION_INFO_ID   | VARCHAR(32)    | identifier string of the implementation information item                                                      |
| IMPLEMENTATION_INFO_NAME | VARCHAR(1024)  | descriptive name of the implementation information item                                                       |
| INTEGER_VALUE            | NATIVE_INTEGER | value of the implementation information item, or null if the value is contained in the column CHARACTER_VALUE |
| CHARACTER_VALUE          | VARCHAR(32)    | value of the implementation information item, or null if the value is contained in the column INTEGER_VALUE   |
| COMMENTS                 | VARCHAR(1024)  | possibly a comment pertaining to the implementation information item                                          |

## SQL\_PACKAGES

List the packages of this ISO/IEC 9075 standard, and indicate which of these the SQL-implementation supports.

**Table 9-198** Column information

| Column name    | Data type     | Description                                                                                                                                                                                                                                                           |
|----------------|---------------|-----------------------------------------------------------------------------------------------------------------------------------------------------------------------------------------------------------------------------------------------------------------------|
| ID             | VARCHAR(32)   | identifier string of the conformance element                                                                                                                                                                                                                          |
| NAME           | VARCHAR(1024) | descriptive name of the conformance element                                                                                                                                                                                                                           |
| IS_SUPPORTED   | BOOLEAN       | TRUE if an SQL-implementation fully supports that conformance element described when SQL-data in the identified catalog is accessed through that implementation, FALSE if not                                                                                         |
| IS_VERIFIED_BY | VARCHAR(1024) | If full support for the conformance element described has been verified by testing, then the IS_VERIFIED_BY column shall contain information identifying the conformance test used to verify the conformance claim; otherwise, IS_VERIFIED_BY shall be the null value |
| COMMENTS       | VARCHAR(1024) | possibly a comment pertaining to the conformance element                                                                                                                                                                                                              |

## SQL\_PARTS

List the parts of this ISO/IEC 9075 standard, and indicate which of these the SQL-implementation supports.

**Table 9-199** Column information

| Column name    | Data type     | Description                                                                                                                                                                                                                                                           |
|----------------|---------------|-----------------------------------------------------------------------------------------------------------------------------------------------------------------------------------------------------------------------------------------------------------------------|
| ID             | VARCHAR(32)   | identifier string of the conformance element                                                                                                                                                                                                                          |
| NAME           | VARCHAR(1024) | descriptive name of the conformance element                                                                                                                                                                                                                           |
| IS_SUPPORTED   | BOOLEAN       | TRUE if an SQL-implementation fully supports that conformance element described when SQL-data in the identified catalog is accessed through that implementation, FALSE if not                                                                                         |
| IS_VERIFIED_BY | VARCHAR(1024) | If full support for the conformance element described has been verified by testing, then the IS_VERIFIED_BY column shall contain information identifying the conformance test used to verify the conformance claim; otherwise, IS_VERIFIED_BY shall be the null value |
| COMMENTS       | VARCHAR(1024) | possibly a comment pertaining to the conformance element                                                                                                                                                                                                              |

## SQL\_SIZING

List the sizing items of this ISO/IEC 9075 standard, for each of these, indicate the size supported by the SQL-implementation.

**Table 9-200** Column information

| Column name     | Data type      | Description                                                                                                                                                        |
|-----------------|----------------|--------------------------------------------------------------------------------------------------------------------------------------------------------------------|
| SIZING_ID       | NATIVE_INTEGER | identifier of the sizing item                                                                                                                                      |
| SIZING_NAME     | VARCHAR(1024)  | descriptive name of the sizing item                                                                                                                                |
| SUPPORTED_VALUE | NATIVE_INTEGER | value of the sizing item, or 0 if the size is unlimited or cannot be determined, or null if the features for which the sizing item is applicable are not supported |
| COMMENTS        | VARCHAR(1024)  | possibly a comment pertaining to the sizing item                                                                                                                   |

## STATISTICS

Provide a list of statistics about a single table and the indexes associated with the table that are accessible to a given user or role.

**Table 9-201** Column information

| Column name        | Data type     | Description                                                                                                                                         |
|--------------------|---------------|-----------------------------------------------------------------------------------------------------------------------------------------------------|
| TABLE_CATALOG      | VARCHAR(128)  | catalog name of the table                                                                                                                           |
| TABLE_OWNER        | VARCHAR(128)  | owner name of the table                                                                                                                             |
| TABLE_SCHEMA       | VARCHAR(128)  | schema name of the table                                                                                                                            |
| TABLE_NAME         | VARCHAR(128)  | table name of the table                                                                                                                             |
| STAT_TYPE          | VARCHAR(32)   | statistics type: the value in ( TABLE STAT, INDEX CLUSTERED, INDEX HASHED, INDEX OTHER )                                                            |
| NON_UNIQUE         | BOOLEAN       | indicates whether the index does not allow duplicate values                                                                                         |
| INDEX_CATALOG      | VARCHAR(128)  | catalog name of the index                                                                                                                           |
| INDEX_OWNER        | VARCHAR(128)  | owner name of the index                                                                                                                             |
| INDEX_SCHEMA       | VARCHAR(128)  | schema name of the index                                                                                                                            |
| INDEX_NAME         | VARCHAR(128)  | name of the index                                                                                                                                   |
| COLUMN_NAME        | VARCHAR(128)  | column name that participates in the index                                                                                                          |
| ORDINAL_POSITION   | NUMBER        | ordinal position of the specific column in the index described                                                                                      |
| IS_ASCENDING_ORDER | BOOLEAN       | index key column being described is sorted in ASCENDING(TRUE) or DESCENDING(FALSE) order                                                            |
| IS_NULLS_FIRST     | BOOLEAN       | the null values of the key column are sorted before(TRUE) or after(FALSE) non-null values                                                           |
| CARDINALITY        | NUMBER        | if STAT_TYPE is (TABLE TYPE), then this is the number of rows in the table; otherwise, it is the number of unique values in the index               |
| PAGES              | NUMBER        | if STAT_TYPE is (TABLE TYPE), then this is the number of pages used for the table; otherwise, it is the number of pages used for the current index. |
| FILTER_CONDITION   | VARCHAR(1024) | filter condition, if any.                                                                                                                           |
| COMMENTS           | VARCHAR(1024) | if STAT_TYPE is (TABLE TYPE), then this is the table comments; otherwise, it is the index comments.                                                 |

## TABLES

Identify the tables defined in this catalog that are accessible to a given user or role

**Table 9-202** Column information

| Column name                      | Data type                      | Description                                                                                                                             |
|----------------------------------|--------------------------------|-----------------------------------------------------------------------------------------------------------------------------------------|
| TABLE_CATALOG                    | VARCHAR(128)                   | catalog name of the table                                                                                                               |
| TABLE_OWNER                      | VARCHAR(128)                   | owner name of the table                                                                                                                 |
| TABLE_SCHEMA                     | VARCHAR(128)                   | schema name of the table                                                                                                                |
| TABLE_NAME                       | VARCHAR(128)                   | table name of the table                                                                                                                 |
| TABLE_TYPE                       | VARCHAR(32)                    | the value is in ( BASE TABLE, VIEW, GLOBAL TEMPORARY, LOCAL TEMPORARY, SYSTEM VERSIONED, FIXED TABLE, DUMP TABLE )                      |
| DBC_TABLE_TYPE                   | VARCHAR(32)                    | ODBC/JDBC table type: the value is in ( TABLE, VIEW, GLOBAL TEMPORARY, LOCAL TEMPORARY, IMMUTABLE TABLE, SYSTEM TABLE, ALIAS, SYNONYM ) |
| TABLESPACE_NAME                  | VARCHAR(128)                   | tablespace name of the table, NULL if view                                                                                              |
| SYSTEM_VERSION_START_COLUMN_NAME | VARCHAR(128)                   | if the table is a system-versioned table, then the name of the system-version start column of the table                                 |
| SYSTEM_VERSION_END_COLUMN_NAME   | VARCHAR(128)                   | if the table is a system-versioned table, then the name of the system-version end column of the table                                   |
| SYSTEM_VERSION_RETENTION_PERIOD  | VARCHAR(32)                    | if the table is a system-versioned table, then the character representation of the value of the retention period of the table           |
| SELF_REFERENCING_COLUMN_NAME     | VARCHAR(128)                   | if the table is a typed table, then the name of the self-referencing column of the table                                                |
| REFERENCE_GENERATION             | VARCHAR(32)                    | if the table has a self-referencing column, the value is in ( SYSTEM GENERATED, USER GENERATED, DERIVED )                               |
| USER_DEFINED_TYPE_CATALOG        | VARCHAR(128)                   | if the table being described is a table of a structured type, the catalog name of the structured type                                   |
| USER_DEFINED_TYPE_SCHEMA         | VARCHAR(128)                   | if the table being described is a table of a structured type, the schema name of the structured type                                    |
| USER_DEFINED_TYPE_NAME           | VARCHAR(128)                   | if the table being described is a table of a structured type, the name of the structured type                                           |
| IS_INSERTABLE_INTO               | BOOLEAN                        | is an insertable-into table                                                                                                             |
| IS_TYPED                         | BOOLEAN                        | is a typed table                                                                                                                        |
| COMMIT_ACTION                    | VARCHAR(32)                    | if the table is a temporary table, the value is in ( DELETE, PRESERVE )                                                                 |
| CREATED_TIME                     | TIMESTAMP(2) WITHOUT TIME ZONE | created time of the table                                                                                                               |
| MODIFIED_TIME                    | TIMESTAMP(2) WITHOUT TIME ZONE | last modified time of the table                                                                                                         |
| COMMENTS                         | VARCHAR(1024)                  | comments of the table                                                                                                                   |

## TABLE\_CONSTRAINTS

Identify the table constraints defined on tables in this catalog that are accessible to a given user or role

**Table 9-203** Column information

| Column name        | Data type                      | Description                                                                                    |
|--------------------|--------------------------------|------------------------------------------------------------------------------------------------|
| CONSTRAINT_CATALOG | VARCHAR(128)                   | catalog name of the constraint                                                                 |
| CONSTRAINT_OWNER   | VARCHAR(128)                   | authorization name who owns the constraint                                                     |
| CONSTRAINT_SCHEMA  | VARCHAR(128)                   | schema name of the constraint being described                                                  |
| CONSTRAINT_NAME    | VARCHAR(128)                   | constraint name                                                                                |
| TABLE_CATALOG      | VARCHAR(128)                   | catalog name of the table to which the table constraint being described applies                |
| TABLE_OWNER        | VARCHAR(128)                   | authorization name who owns the table to to which the table constraint being described applies |
| TABLE_SCHEMA       | VARCHAR(128)                   | schema name of the table to to which the table constraint being described applies              |
| TABLE_NAME         | VARCHAR(128)                   | table name of the table to to which the table constraint being described applies               |
| CONSTRAINT_TYPE    | VARCHAR(32)                    | the value is in ( PRIMARY KEY, UNIQUE, FOREIGN KEY, NOT NULL, CHECK )                          |
| IS_DEFERRABLE      | BOOLEAN                        | is a deferrable constraint                                                                     |
| INITIALLY_DEFERRED | BOOLEAN                        | is an initially deferred constraint                                                            |
| ENFORCED           | BOOLEAN                        | is an enforced constraint                                                                      |
| CREATED_TIME       | TIMESTAMP(2) WITHOUT TIME ZONE | created time of the constraint                                                                 |
| MODIFIED_TIME      | TIMESTAMP(2) WITHOUT TIME ZONE | last modified time of the constraint                                                           |
| COMMENTS           | VARCHAR(1024)                  | comments of the constraint                                                                     |

## TABLE\_PRIVILEGES

Identify the privileges on tables of tables defined in this catalog that are available to or granted by a given user or role.

**Table 9-204** Column information

| Column name    | Data type    | Description                                                                                                                      |
|----------------|--------------|----------------------------------------------------------------------------------------------------------------------------------|
| GRANTOR        | VARCHAR(128) | authorization name of the user who granted table privileges                                                                      |
| GRANTEE        | VARCHAR(128) | authorization name of some user or role, or PUBLIC to indicate all users, to whom the table privilege being described is granted |
| TABLE_CATALOG  | VARCHAR(128) | catalog name of the table on which the privilege being described was granted                                                     |
| TABLE_OWNER    | VARCHAR(128) | table owner name of the table on which the privilege being described was granted                                                 |
| TABLE_SCHEMA   | VARCHAR(128) | schema name of the table on which the privilege being described was granted                                                      |
| TABLE_NAME     | VARCHAR(128) | table name on which the privilege being described was granted                                                                    |
| PRIVILEGE_TYPE | VARCHAR(32)  | the value is in ( CONTROL, SELECT, INSERT, UPDATE, DELETE, REFERENCES, LOCK, INDEX, ALTER )                                      |
| IS_GRANTABLE   | BOOLEAN      | is grantable                                                                                                                     |
| WITH_HIERARCHY | BOOLEAN      | whether the privilege was granted WITH HIERARCHY OPTION or not                                                                   |



## USAGE\_PRIVILEGES

Identify the USAGE privileges on objects defined in this catalog that are available to or granted by a given user or role.

**Table 9-205** Column information

| Column name    | Data type    | Description                                                                                                                            |
|----------------|--------------|----------------------------------------------------------------------------------------------------------------------------------------|
| GRANTOR        | VARCHAR(128) | authorization name of the user who granted usage privileges, on the object of the type identified by OBJECT_TYPE                       |
| GRANTEE        | VARCHAR(128) | authorization identifier of some user or role, or PUBLIC to indicate all users, to whom the usage privilege being described is granted |
| OBJECT_CATALOG | VARCHAR(128) | catalog name of the object of the type identified by OBJECT_TYPE on which the privilege being described was granted                    |
| OBJECT_OWNER   | VARCHAR(128) | owner name of the object of the type identified by OBJECT_TYPE on which the privilege being described was granted                      |
| OBJECT_SCHEMA  | VARCHAR(128) | schema name of the object of the type identified by OBJECT_TYPE on which the privilege being described was granted                     |
| OBJECT_NAME    | VARCHAR(128) | object name of the type identified by OBJECT_TYPE on which the privilege being described was granted                                   |
| OBJECT_TYPE    | VARCHAR(32)  | the value is in ( DOMAIN, CHARACTER SET, COLLATION, TRANSLATION, SEQUENCE )                                                            |
| PRIVILEGE_TYPE | VARCHAR(32)  | the value is in ( USAGE )                                                                                                              |
| IS_GRANTABLE   | BOOLEAN      | is grantable                                                                                                                           |

## VIEWS

Identify the viewed tables defined in this catalog that are accessible to a given user or role.

**Table 9-206** Column information

| Column name                | Data type     | Description                                                                                                        |
|----------------------------|---------------|--------------------------------------------------------------------------------------------------------------------|
| TABLE_CATALOG              | VARCHAR(128)  | catalog name of the viewed table                                                                                   |
| TABLE_OWNER                | VARCHAR(128)  | owner name of the viewed table                                                                                     |
| TABLE_SCHEMA               | VARCHAR(128)  | schema name of the viewed table                                                                                    |
| TABLE_NAME                 | VARCHAR(128)  | view name of the viewed table                                                                                      |
| VIEW_DEFINITION            | LONG VARCHAR  | the character representation of the user-specified query expression contained in the corresponding view descriptor |
| CHECK_OPTION               | VARCHAR(32)   | the value is in ( CASCADED, LOCAL, NONE )                                                                          |
| IS_UPDATABLE               | BOOLEAN       | is an updatable view                                                                                               |
| INSERTABLE_INTO            | BOOLEAN       | is an insertable view                                                                                              |
| IS_TRIGGER_UPDATABLE       | BOOLEAN       | whether an update INSTEAD OF trigger is defined on the view or not                                                 |
| IS_TRIGGER_DELETABLE       | BOOLEAN       | whether a delete INSTEAD OF trigger is defined on the view or not                                                  |
| IS_TRIGGER_INSERTABLE_INTO | BOOLEAN       | whether an insert INSTEAD OF trigger is defined on the view or not                                                 |
| IS_COMPILED                | BOOLEAN       | whether the view is compiled or not                                                                                |
| IS_AFFECTED                | BOOLEAN       | whether the view is affected by modification of underlying object or not                                           |
| COMMENTS                   | VARCHAR(1024) | comments of the view                                                                                               |

## VIEW\_MODULE\_USAGE

Identify the SQL-server modules owned by a given user or role on which views defined in this catalog are dependent.

**Table 9-207** Column information

| Column name    | Data type    | Description                                                                       |
|----------------|--------------|-----------------------------------------------------------------------------------|
| TABLE_CATALOG  | VARCHAR(128) | catalog name of the viewed table                                                  |
| TABLE_OWNER    | VARCHAR(128) | owner name of the viewed table                                                    |
| TABLE_SCHEMA   | VARCHAR(128) | schema name of the viewed table                                                   |
| TABLE_NAME     | VARCHAR(128) | view name of the viewed table                                                     |
| MODULE_CATALOG | VARCHAR(128) | catalog name of the SQL-server module of contained in definition text of the view |
| MODULE_OWNER   | VARCHAR(128) | owner name of the SQL-server module of contained in definition text of the view   |
| MODULE_SCHEMA  | VARCHAR(128) | schema name of the SQL-server module of contained in definition text of the view' |
| MODULE_NAME    | VARCHAR(128) | SQL-server module name of contained in definition text of the view                |

## VIEW\_ROUTINE\_USAGE

Identify each routine owned by a given user or role on which a view defined in this catalog is dependent.

**Table 9-208** Column information

| Column name      | Data type    | Description                                                                                      |
|------------------|--------------|--------------------------------------------------------------------------------------------------|
| TABLE_CATALOG    | VARCHAR(128) | catalog name of the viewed table                                                                 |
| TABLE_OWNER      | VARCHAR(128) | owner name of the viewed table                                                                   |
| TABLE_SCHEMA     | VARCHAR(128) | schema name of the viewed table                                                                  |
| TABLE_NAME       | VARCHAR(128) | view name of the viewed table                                                                    |
| SPECIFIC_CATALOG | VARCHAR(128) | specific catalog name of a routine contained in the query expression of the view being described |
| SPECIFIC_OWNER   | VARCHAR(128) | specific owner name of a routine contained in the query expression of the view being described   |
| SPECIFIC_SCHEMA  | VARCHAR(128) | specific schema name of a routine contained in the query expression of the view being described  |
| SPECIFIC_NAME    | VARCHAR(128) | specific name of a routine contained in the query expression of the view being described         |

## VIEW\_TABLE\_USAGE

Identify the tables on which viewed tables defined in this catalog and owned by a given user or role are dependent.

**Table 9-209** Column information

| Column name   | Data type    | Description                                                                                                                               |
|---------------|--------------|-------------------------------------------------------------------------------------------------------------------------------------------|
| VIEW_CATALOG  | VARCHAR(128) | catalog name of the viewed table                                                                                                          |
| VIEW_OWNER    | VARCHAR(128) | owner name of the viewed table                                                                                                            |
| VIEW_SCHEMA   | VARCHAR(128) | schema name of the viewed table                                                                                                           |
| VIEW_NAME     | VARCHAR(128) | view name of the viewed table                                                                                                             |
| TABLE_CATALOG | VARCHAR(128) | catalog name of a table that is explicitly or implicitly referenced in the original query expression of the compiled view being described |
| TABLE_OWNER   | VARCHAR(128) | owner name of a table that is explicitly or implicitly referenced in the original query expression of the compiled view being described   |
| TABLE_SCHEMA  | VARCHAR(128) | schema name of a table that is explicitly or implicitly referenced in the original query expression of the compiled view being described  |
| TABLE_NAME    | VARCHAR(128) | table name of a table that is explicitly or implicitly referenced in the original query expression of the compiled view being described   |

## 9.3 PERFORMANCE\_VIEW\_SCHEMA

PERFORMANCE\_VIEW\_SCHEMA schema consists of views which can retrieve the current state of the system.

Execute *PerformanceViewSchema.sql* as follows to use the views.

- For standalone

```
% gsql sys gliese --as sysdba --import
$GOLDILOCKS_HOME/admin/standalone/PerformanceViewSchema.sql
```

- For cluster

```
% gsql sys gliese --as sysdba --import
$GOLDILOCKS_HOME/admin/cluster/PerformanceViewSchema.sql
```

The retrievable information of PERFORMANCE\_VIEW\_SCHEMA views vary upon its phase of the startup. (nomount, mount, open)

Execute the followings to figure out the startup phase in which each views are retrieved.

```
gSQL> select table_name, startup_phase from v$tables order by 1;
```

| TABLE_NAME                  | STARTUP_PHASE |
|-----------------------------|---------------|
| V\$AGABLE_INFO              | OPEN          |
| V\$ARCHIVELOG               | MOUNT         |
| V\$AUDITABLE_DB_PRIVILEGES  | NO_MOUNT      |
| V\$AUDITABLE_SYSTEM_ACTIONS | NO_MOUNT      |
| V\$BACKUP                   | MOUNT         |
| V\$BALANCER                 | OPEN          |
| V\$BCH                      | MOUNT         |
| V\$BUFFER_STAT              | MOUNT         |
| V\$COLUMNS                  | OPEN          |
| V\$CONTROLFILE              | MOUNT         |
| V\$DATAFILE                 | MOUNT         |
| V\$DB_CHANGE_TRACKING       | MOUNT         |
| V\$DB_FILE                  | MOUNT         |
| V\$DISPATCHER               | OPEN          |
| V\$ERROR_CODE               | NO_MOUNT      |
| V\$INCREMENTAL_BACKUP       | MOUNT         |
| V\$INSTANCE                 | NO_MOUNT      |

|                         |               |
|-------------------------|---------------|
| V\$KEYWORDS             | NO_MOUNT      |
| V\$LATCH                | NO_MOUNT      |
| V\$LOCK_WAIT            | OPEN          |
| TABLE_NAME              | STARTUP_PHASE |
| -----                   |               |
| V\$LOGFILE              | MOUNT         |
| V\$PLAN_HISTORY         | OPEN          |
| V\$PLAN_HISTORY_LATEST  | OPEN          |
| V\$PROCESS_MEM_STAT     | NO_MOUNT      |
| V\$PROCESS_SQL_STAT     | NO_MOUNT      |
| V\$PROCESS_STAT         | NO_MOUNT      |
| V\$PROPERTY             | NO_MOUNT      |
| V\$PSM_RESERVED_WORDS   | NO_MOUNT      |
| V\$QUEUE                | OPEN          |
| V\$RESERVED_WORDS       | NO_MOUNT      |
| V\$SEQUENCE             | OPEN          |
| V\$SESSION              | NO_MOUNT      |
| V\$SESSION_AUDIT        | OPEN          |
| V\$SESSION_CONNECT_INFO | NO_MOUNT      |
| V\$SESSION_EVENT        | OPEN          |
| V\$SESSION_MEM_STAT     | NO_MOUNT      |
| V\$SESSION_SQL_STAT     | NO_MOUNT      |
| V\$SESSION_STAT         | NO_MOUNT      |
| V\$SESSION_WAIT         | OPEN          |
| V\$SHARED_MODE          | OPEN          |
| TABLE_NAME              | STARTUP_PHASE |
| -----                   |               |
| V\$SHARED_SERVER        | OPEN          |
| V\$SHM_SEGMENT          | NO_MOUNT      |
| V\$SPROPERTY            | NO_MOUNT      |
| V\$SQLFN_METADATA       | NO_MOUNT      |
| V\$SQL_CACHE            | NO_MOUNT      |
| V\$SQL_COMMAND          | NO_MOUNT      |
| V\$SQL_HISTORY          | NO_MOUNT      |
| V\$STATEMENT            | NO_MOUNT      |
| V\$SYSTEM_EVENT         | OPEN          |
| V\$SYSTEM_MEM_STAT      | NO_MOUNT      |
| V\$SYSTEM_SQL_STAT      | NO_MOUNT      |
| V\$SYSTEM_STAT          | NO_MOUNT      |
| V\$TABLES               | NO_MOUNT      |
| V\$TABLESPACE           | MOUNT         |

```
V$TABLESPACE_STAT      OPEN
V$TRANSACTION           OPEN
V$WAIT_EVENT_CLASS_NAME OPEN
V$WAIT_EVENT_NAME      OPEN
V$XA_TRANSACTION        OPEN
59 rows selected.
```



## GV\$ Global View

The cluster provides GV\$ view corresponding to almost every V\$ views.

V\$ view retrieves the information of the currently connected server, but GV\$ view retrieves the information of all servers.

GV\$ view includes all column information of V\$ view, and it additionally has ORIGIN\_MEMBER\_NAME column which is a server having acquired the data (cluster member).



It is available only on a cluster.

For example, V\$TRANSACTION information retrieves the transaction information of the currently connected server as follows.

```
gSQL> SELECT TRANS_ID, SESSION_ID, TRANS_VIEW_SCN, START_TIME FROM V$TRANSACTION;
TRANS_ID SESSION_ID TRANS_VIEW_SCN START_TIME
-----
40501296      48 1098.1.26      2017-04-07 17:14:01.912637
```

On the other hand, GV\$TRANSACTION information retrieves the transaction information of all servers as follows.

```
gSQL> SELECT ORIGIN_MEMBER_NAME, TRANS_ID, SESSION_ID, TRANS_VIEW_SCN, START_TIME FROM
GV$TRANSACTION;
ORIGIN_MEMBER_NAME TRANS_ID SESSION_ID TRANS_VIEW_SCN START_TIME
-----
G1N1      40501296      48 1098.1.26      2017-04-07 17:14:01.912637
G2N2      40304688      48 1098.0.888      2017-04-07 17:14:55.134015
G2N1      42205232      48 1098.0.888      2017-04-07 17:14:55.135996
G1N2      40435760      48 1098.1.889      2017-04-07 17:14:01.910138
```

In the example above, the ORIGIN\_MEMBER\_NAME information indicates that the transaction information were obtained from the cluster members corresponding to G1N1, G2N1, G1N2, G2N2 each.

The information of a specific remote server can be retrieved by using the condition for ORIGIN\_MEMBER\_NAME column as follows.

```
gSQL>
SELECT ORIGIN_MEMBER_NAME, TRANS_ID, SESSION_ID, TRANS_VIEW_SCN, START_TIME
FROM GV$TRANSACTION
WHERE ORIGIN_MEMBER_NAME IN ( 'G2N1', 'G3N2' );
```

| ORIGIN_MEMBER_NAME | TRANS_ID | SESSION_ID | TRANS_VIEW_SCN | START_TIME                 |
|--------------------|----------|------------|----------------|----------------------------|
| G3N2               | 32178224 | 48         | 1099.0.888     | 2017-04-07 17:33:10.934752 |
| G2N1               | 42270768 | 48         | 1099.0.888     | 2017-04-07 17:31:14.726007 |

2 rows selected.

## V\$AGABLE\_INFO

The V\$AGABLE\_INFO displays the system agable information.

**Table 9-210** Column information

| Column name       | Data type   | Description                           |
|-------------------|-------------|---------------------------------------|
| SCN               | VARCHAR(32) | system scn                            |
| AGABLE_SCN        | VARCHAR(32) | system agable scn                     |
| AGABLE_SCN_GAP    | VARCHAR(32) | gap between system scn and agable scn |
| OLDEST_SESSION_ID | NUMBER      | identifier of session blocking aging  |

## V\$ARCHIVELOG

The V\$ARCHIVELOG displays information of log archiving.

**Table 9-211** Column information

| Column name            | Data type     | Description                                                  |
|------------------------|---------------|--------------------------------------------------------------|
| ARCHIVELOG_MODE        | VARCHAR(32)   | database log mode: the value in ( NOARCHIVELOG, ARCHIVELOG ) |
| LAST_ARCHIVED_LOG      | NUMBER        | sequence number of last archived log file                    |
| ARCHIVELOG_DIR         | VARCHAR(1024) | archive destination path                                     |
| ARCHIVELOG_FILE_PREFIX | VARCHAR(128)  | file prefix name of the archived log                         |

## V\$AUDITABLE\_DB\_PRIVILEGES

The V\$AUDITABLE\_DB\_PRIVILEGES displays auditable database privileges.

**Table 9-212** Column information

| Column name    | Data type    | Description                   |
|----------------|--------------|-------------------------------|
| PRIVILEGE_ID   | NUMBER       | database privilege identifier |
| PRIVILEGE_NAME | VARCHAR(128) | database privilege name       |

## V\$AUDITABLE\_SYSTEM\_ACTIONS

The V\$AUDITABLE\_SYSTEM\_ACTIONS displays auditable system actions.

**Table 9-213** Column information

| Column name | Data type    | Description                        |
|-------------|--------------|------------------------------------|
| ACTION_ID   | NUMBER       | auditable system action identifier |
| ACTION_NAME | VARCHAR(128) | auditable system action name       |

## V\$BACKUP

The V\$BACKUP displays information of backup.

**Table 9-214** Column information

| Column name   | Data type    | Description                                                                   |
|---------------|--------------|-------------------------------------------------------------------------------|
| TBS_NAME      | VARCHAR(128) | tablespace name                                                               |
| BACKUP_STATUS | VARCHAR(16)  | indicates whether the tablespace begin backup ( ACTIVE ) or not ( I NACTIVE ) |
| BACKUP_LSN    | NUMBER       | the last checkpoint lsn of tablespace when backup started                     |

## V\$BALANCER

The V\$BALANCER displays information of balancer.

**Table 9-215** Column information

| Column name           | Data type   | Description                   |
|-----------------------|-------------|-------------------------------|
| PROCESS_ID            | NUMBER      | balancer process identifier   |
| CUR_CONNECTIONS       | NUMBER      | current number of connections |
| CONNECTIONS           | NUMBER      | total number of connections   |
| CONNECTIONS_HIGHWATER | NUMBER      | highest number of connections |
| MAX_CONNECTIONS       | NUMBER      | maximum connections           |
| STATUS                | VARCHAR(16) | status                        |



## V\$BCH

The V\$BCH displays information of database buffer control header array.

**Table 9-216** Column information

| Column name                       | Data type                       | Description                                                                               |
|-----------------------------------|---------------------------------|-------------------------------------------------------------------------------------------|
| BCH_SEQ                           | NUMBER                          | bch sequence                                                                              |
| TABLESPACE_ID                     | NUMBER                          | tablespace identifier of the page cached in the frame of bch                              |
| PAGE_ID                           | NUMBER                          | page identifier of the page cached in the frame of bch                                    |
| LOGICAL_ADDRESS                   | VARCHAR(18)                     | logical address of the frame of bch                                                       |
| DIRTY                             | BOOLEAN                         | dirty state of the page cached in the frame of bch                                        |
| PGAE_TYPE                         | VARCHAR(20)                     | page type of the page cached in the frame of bch                                          |
| FIRST_DIRTY_LSN                   | NUMBER                          | first dirty lsn of the page cached in the frame of bch                                    |
| RECOVERY_LSN                      | NUMBER                          | recovery lsn of the page cached in the frame of bch                                       |
| LAST_FLUSHED_LSN                  | NUMBER                          | last flushed lsn of the page cached in the frame of bch                                   |
| FIXED_COUNT                       | NUMBER                          | fixed count of the page cached in the frame of bch                                        |
| TOUCHED_COUNT                     | NUMBER                          | touched count of the page cached in the frame of bch                                      |
| RECENT_TOUCH_COUNT_INCREASED_TIME | TIMESTAMP(2) WITH OUT TIME ZONE | timestamp that touch count of the page cached in the frame of bch increased most recently |
| BCH_LIST_TYPE                     | VARCHAR(16)                     | list type to which the bch belongs                                                        |
| BCH_STATE                         | VARCHAR(16)                     | bch state                                                                                 |

## V\$BUFFER\_STAT

The V\$BUFFER\_STAT displays database buffer statistics.

**Table 9-217** Column information

| Column name           | Data type | Description                                               |
|-----------------------|-----------|-----------------------------------------------------------|
| BUFFER_POOL_SIZE      | NUMBER    | total buffer frame size ( page count )                    |
| HASH_BUCKET_COUNT     | NUMBER    | buffer hash bucket count                                  |
| LRU_LIST_COUNT        | NUMBER    | buffer lru list count                                     |
| HOT_REGION_PERCENTAGE | NUMBER    | percentage of lru hot region                              |
| HOT_REGION_CRITERIA   | NUMBER    | touch count criteria of lru hot region                    |
| CHECKPOINT_LIST_COUNT | NUMBER    | buffer checkpoint list count                              |
| FLUSH_LIST_COUNT      | NUMBER    | buffer flush list count                                   |
| FREE_LIST_COUNT       | NUMBER    | buffer free list count                                    |
| FREE_BUFFER_WAIT      | NUMBER    | total number of waiting for free list                     |
| READ_COMPLETE_WAIT    | NUMBER    | total number of waiting for read page complete            |
| BUFFER_LOOKUPS        | NUMBER    | total number of lookups in the buffer for requested pages |
| BUFFER_HIT            | NUMBER    | total number of hits in the buffer for requested pages    |
| BUFFER_MISS           | NUMBER    | total number of misses in the buffer for requested pages  |
| TOTAL_WRITES          | NUMBER    | total number of physical writes                           |
| TOTAL_READS           | NUMBER    | total number of physical reads                            |
| FLUSH_PER_SECOND      | NUMBER    | total number of disk writes per one second                |
| READ_PER_SECOND       | NUMBER    | total number of disk reads per one second                 |
| AVERAGE_WRITE_LATENCY | NUMBER    | average latency of disk writes                            |
| AVERAGE_READ_LATENCY  | NUMBER    | average latency of disk reads                             |

## V\$CLUSTER\_DISPATCHER

The V\$CLUSTER\_DISPATCHER displays cluster dispatcher information.



It is available only on a cluster.

**Table 9-218** Column information

| Column name   | Data type | Description                                                      |
|---------------|-----------|------------------------------------------------------------------|
| DISPATCHER_ID | NUMBER    | dispatcher identifier                                            |
| IS_SYNC       | BOOLEAN   | whether the dispatcher is sync or not                            |
| RX_BYTES      | NUMBER    | total amount of data that has received through the dispatcher    |
| TX_BYTES      | NUMBER    | total amount of data that has transmitted through the dispatcher |
| RX_JOBS       | NUMBER    | the total number of jobs received                                |
| TX_JOBS       | NUMBER    | the total number of jobs transmitted                             |

## V\$CLUSTER\_LOCATION

The V\$CLUSTER\_LOCATION displays cluster location information.



It is available only on a cluster.

**Table 9-219** Column information

| Column name | Data type    | Description              |
|-------------|--------------|--------------------------|
| MEMBER_NAME | VARCHAR(128) | member name              |
| HOST        | VARCHAR(128) | host address of a member |
| PORT        | NUMBER       | host port of a member    |

## V\$CLUSTER\_MEMBER

The V\$CLUSTER\_MEMBER displays cluster member information.



It is available only on a cluster.

**Table 9-220** Column information

| Column name     | Data type   | Description                                                            |
|-----------------|-------------|------------------------------------------------------------------------|
| MEMBER_ID       | NUMBER      | member identifier                                                      |
| MEMBER_POSITION | NUMBER      | member position                                                        |
| STATUS          | VARCHAR(64) | status of the member: the value in ( ACTIVE, INACTIVE )                |
| IS_GLOBAL_COORD | BOOLEAN     | indicates whether a member is global coordinator (TRUE) or not (FALSE) |
| IS_GROUP_COORD  | BOOLEAN     | indicates whether a member is group coordinator (TRUE) or not (FALSE)  |

## V\$COLUMNS

The V\$COLUMNS has one row for each column of all the performance views (views beginning with V\$).

Execute \desc as follows to retrieve the column information of performance view in nomount or mount phase in which V\$COLUMNS is not available.

```

gSQL> \desc V$INSTANCE
COLUMN_NAME      TYPE                                IS_NULLABLE
-----
RELEASE_VERSION  VARCHAR(64)                        FALSE
STARTUP_TIME     TIMESTAMP(2) WITHOUT TIME ZONE    FALSE
INSTANCE_STATUS  VARCHAR(16)                        FALSE

```

**Table 9-221** Column information

| Column name      | Data type     | Description                                                      |
|------------------|---------------|------------------------------------------------------------------|
| TABLE_OWNER      | VARCHAR(128)  | owner name who owns the performance view                         |
| TABLE_SCHEMA     | VARCHAR(128)  | schema name of the performance view                              |
| TABLE_NAME       | VARCHAR(128)  | name of the performance view                                     |
| COLUMN_NAME      | VARCHAR(128)  | column name                                                      |
| ORDINAL_POSITION | NUMBER        | the ordinal position (> 0) of the column in the performance view |
| DATA_TYPE        | VARCHAR(128)  | the data type name that a user declared                          |
| DATA_PRECISION   | NUMBER        | the precision value that a user declared                         |
| DATA_SCALE       | NUMBER        | the scale value that a user declared                             |
| COMMENTS         | VARCHAR(1024) | comments of the column                                           |

## V\$CONTROLFILE

This view displays information about GOLDILOCKS control files.

**Table 9-222** Column information

| Column name         | Data type     | Description                                   |
|---------------------|---------------|-----------------------------------------------|
| STATUS              | VARCHAR(16)   | control file status ( VALID, CORRUPTED )      |
| CONTROLFILE_NAME    | VARCHAR(1152) | control file name ( absolute path )           |
| LAST_CHECKPOINT_LSN | NATIVE_BIGINT | the last checkpoint lsn                       |
| IS_PRIMARY          | BOLLEAN       | indicates whether the control file is primary |

## V\$DATAFILE

The V\$DATAFILE displays information of all datafiles.

**Table 9-223** Column information

| Column name           | Data type                          | Description                                             |
|-----------------------|------------------------------------|---------------------------------------------------------|
| TBS_NAME              | VARCHAR(128)                       | tablespace name                                         |
| DATAFILE_NAME         | VARCHAR(1024)                      | datafile name ( absolute path )                         |
| CHECKPOINT_LSN        | NUMBER                             | LSN at last checkpoint ( null if temporary tablespace ) |
| CREATION_TIME         | TIMESTAMP(2) WITH<br>OUT TIME ZONE | timestamp of the datafile creation                      |
| FILE_SIZE             | NUMBER                             | datafile size ( in bytes )                              |
| LOADED_CHECKPOINT_LSN | NUMBER                             | checkpoint LSN of the datafile loaded in memory         |
| CORRUPT_PAGE_COUNT    | NUMBER                             | number of corrupt pages in the datafile                 |



## V\$DB\_CHANGE\_TRACKING

The V\$DB\_CHANGE\_TRACKING displays information of database change tracking.

**Table 9-224** Column information

| Column name               | Data type   | Description                                     |
|---------------------------|-------------|-------------------------------------------------|
| TABLESPACE_ID             | NUMBER      | tablespace identifier                           |
| DATAFILE_ID               | NUMBER      | datafile identifier                             |
| CHANGE_TRACKING_STATE     | VARCHAR(32) | state of datafile change tracking               |
| CHANGE_TRACKING_CHUNK_SEQ | NUMBER      | sequence of change tracking chunk for datafile  |
| MAX_SIZE                  | NUMBER      | maximum size of datafile (byte)                 |
| BITMAP_BLOCK_COUNT        | NUMBER      | bitmap block count of change tracking chunk     |
| LAST_PAGE_SEQ             | NUMBER      | the last page sequence of change tracking chunk |

## V\$DB\_FILE

The V\$DB\_FILE displays a list of all files using in database.

**Table 9-225** Column information

| Column name | Data type     | Description |
|-------------|---------------|-------------|
| FILE_NAME   | VARCHAR(1024) | file name   |
| FILE_TYPE   | VARCHAR(16)   | file type   |

# V\$DISPATCHER

The V\$DISPATCHER displays information of dispatchers.

**Table 9-226** Column information

| Column name           | Data type   | Description                                                    |
|-----------------------|-------------|----------------------------------------------------------------|
| PROCESS_ID            | NUMBER      | dispatcher process identifier                                  |
| RESPONSE_JOB_COUNT    | NUMBER      | response job count                                             |
| ACCEPT                | NUMBER      | indicates whether this dispatcher is accepting new connections |
| START_TIME            | NUMBER      | process start time                                             |
| CUR_CONNECTIONS       | NUMBER      | current number of connections                                  |
| CONNECTIONS           | NUMBER      | total number of connections                                    |
| CONNECTIONS_HIGHWATER | NUMBER      | highest number of connections                                  |
| MAX_CONNECTIONS       | NUMBER      | maximum connections                                            |
| RECV_STATUS           | VARCHAR(16) | receive status                                                 |
| RECV_BYTES            | NUMBER      | total bytes of received                                        |
| RECV_UNITS            | NUMBER      | total units of received                                        |
| RECV_IDLE             | NUMBER      | total idle time of receive (1/100 second)                      |
| RECV_BUSY             | NUMBER      | total busy time of receive (1/100 second)                      |
| SEND_STATUS           | VARCHAR(16) | send status                                                    |
| SEND_BYTES            | NUMBER      | total bytes of sent                                            |
| SEND_UNITS            | NUMBER      | total units of sent                                            |
| SEND_IDLE             | NUMBER      | total idle time of send (1/100 second)                         |
| SEND_BUSY             | NUMBER      | total busy time of send (1/100 second)                         |

## V\$ERROR\_CODE

The V\$ERROR\_CODE displays a list of all GOLDDILOCKS error codes.

**Table 9-227** Column information

| Column name   | Data type     | Description            |
|---------------|---------------|------------------------|
| ERROR_CODE    | NUMBER        | GOLDDILOCKS error code |
| SQL_STATE     | VARCHAR(32)   | standard SQLSTATE code |
| ERROR_MESSAGE | VARCHAR(1024) | error message          |

## V\$GLOBAL\_TRANSACTION

The V\$GLOBAL\_TRANSACTION displays information on the currently active global transactions.

**Table 9-228** Column information

| Column name        | Data type                          | Description                                                                                                            |
|--------------------|------------------------------------|------------------------------------------------------------------------------------------------------------------------|
| GLOBAL_TRANS_ID    | VARCHAR(1024)                      | global transaction identifier                                                                                          |
| LOCAL_TRANS_ID     | NUMBER                             | local transaction identifier                                                                                           |
| GLOBAL_TRANS_STATE | VARCHAR(32)                        | state of the global transaction: the value in ( NOTR, ACTIVE, I<br>DLE, PREPARED, ROLLBACK_ONLY, HEURISTIC_COMPLETED ) |
| ASSO_STATE         | VARCHAR(32)                        | associate state of the global transaction: the value in ( NOT_A<br>SSOCIATED, ASSOCIATED, ASSOCIATION_SUSPENDED )      |
| START_TIME         | TIMESTAMP(2) WITH<br>OUT TIME ZONE | global transaction start time                                                                                          |
| IS_REPREPARABLE    | BOOLEAN                            | indicates whether the global transaction is reparable                                                                  |

## V\$INCREMENTAL\_BACKUP

The V\$INCREMENTAL\_BACKUP displays information about control files and datafiles in backup sets from the control file.

**Table 9-229** Column information

| Column name       | Data type                          | Description                                                              |
|-------------------|------------------------------------|--------------------------------------------------------------------------|
| BACKUP_NAME       | VARCHAR(1024)                      | backup file name ( absolute path )                                       |
| BACKUP_SCOPE      | VARCHAR(128)                       | incremental backup scope: the value in ( database, tablespace, control ) |
| INCREMENTAL_LEVEL | NUMBER                             | incremental backup level: the value in ( 0, 1, 2, 3, 4 )                 |
| INCREMENTAL_TYPE  | VARCHAR(32)                        | incremental backup type: the value in ( DIFFERENTIAL, CUMULATIVE )       |
| LSN               | NUMBER                             | all changes up to checkpoint LSN are included in this backup             |
| BEGIN_TIME        | TIMESTAMP(2) WITH<br>OUT TIME ZONE | incremental backup beginning time                                        |
| COMPLETION_TIME   | TIMESTAMP(2) WITH<br>OUT TIME ZONE | incremental backup completion time                                       |

## V\$INSTANCE

This view displays the state of the current instance.



When database is transited to open phase, it is possible to select *READ ONLY* or *READ WRITE*. If not selected, *DATA\_ACCESS\_MODE* is determined by the value of *DATABASE\_ACCESS\_MODE* property. *DATA\_ACCESS\_MODE* is displayed as *NONE* in nomount or mount phase.

**Table 9-230** Column information

| Column name      | Data type                          | Description                                                                    |
|------------------|------------------------------------|--------------------------------------------------------------------------------|
| RELEASE_VERSION  | VARCHAR(64)                        | release version                                                                |
| STARTUP_TIME     | TIMESTAMP(2) WITH<br>OUT TIME ZONE | time when the instance was started                                             |
| INSTANCE_STATUS  | VARCHAR(16)                        | status of the instance: the value in ( STARTED, MOUNTED, OPEN )                |
| DATA_ACCESS_MODE | VARCHAR(16)                        | data access mode of the instance: the value in ( NONE, READ_ONLY, READ_WRITE ) |

## V\$JOURNALING

The V\$JOURNALING displays journaling information.



It is available only on a cluster.

**Table 9-231** Column information

| Column name  | Data type    | Description                              |
|--------------|--------------|------------------------------------------|
| TABLE_NAME   | VARCHAR(128) | table name                               |
| SHARD_ID     | NUMBER       | shard identifier                         |
| RECORD_COUNT | NUMBER       | journalized record count                 |
| TOTAL_SIZE   | NUMBER       | total size of journalized records (byte) |



## V\$KEYWORDS

The V\$KEYWORDS displays a list of all SQL keywords.

**Table 9-232** Column information

| Column name    | Data type    | Description                                                                                                         |
|----------------|--------------|---------------------------------------------------------------------------------------------------------------------|
| KEYWORD_NAME   | VARCHAR(128) | name of keyword                                                                                                     |
| KEYWORD_LENGTH | NUMBER       | length of the keyword                                                                                               |
| IS_RESERVED    | BOOLEAN      | indicates whether the keyword cannot be used as an identifier (TRUE) or whether the keyword is not reserved (FALSE) |

## V\$LATCH

The V\$LATCH shows latch information.

**Table 9-233** Column information

| Column name       | Data type   | Description                                                     |
|-------------------|-------------|-----------------------------------------------------------------|
| LATCH_DESCRIPTION | VARCHAR(64) | latch description                                               |
| REF_COUNT         | NUMBER      | reference count                                                 |
| SPIN_LOCK         | VARCHAR(3)  | indicates whether the spin lock is locked ( YES ) or not ( NO ) |
| WAIT_COUNT        | NUMBER      | wait count                                                      |
| CURRENT_MODE      | VARCHAR(32) | current latch mode: the value in ( INITIAL, SHARED, EXCLUSIVE ) |

## V\$LOGFILE

The V\$LOGFILE displays information of all redo log members.

**Table 9-234** Column information

| Column name | Data type     | Description                                                                 |
|-------------|---------------|-----------------------------------------------------------------------------|
| GROUP_ID    | NUMBER        | redo log group identifier                                                   |
| FILE_NAME   | VARCHAR(1024) | name of the log member                                                      |
| GROUP_STATE | VARCHAR(32)   | state of the log group: the value in ( UNUSED, ACTIVE, CURRENT, IN ACTIVE ) |
| FILE_SEQ    | NUMBER        | file sequence number of the log member                                      |
| FILE_SIZE   | NUMBER        | file size of the log member ( in bytes )                                    |

## V\$LOCK\_WAIT

This view lists the locks currently held and outstanding requests for a lock.

**Table 9-235** Column information

| Column name      | Data type | Description                                   |
|------------------|-----------|-----------------------------------------------|
| GRANT_TRANS_ID   | NUMBER    | transaction identifier that holds the lock    |
| REQUEST_TRANS_ID | NUMBER    | transaction identifier that requests the lock |

## V\$LOCKED\_OBJECT

This view shows locked object information.

**Table 9-236** Column information

| Column name  | Data type    | Description                           |
|--------------|--------------|---------------------------------------|
| LOCK_SLOT_ID | NUMBER       | lock slot identifier                  |
| TABLE_OWNER  | VARCHAR(128) | owner name who owns the locked table  |
| TABLE_SCHEMA | VARCHAR(128) | schema of the locked table            |
| TABLE_NAME   | VARCHAR(128) | locked table name                     |
| LOCK_MODE    | VARCHAR(8)   | granted lock mode (IS, IX, S, X, SIX) |

## V\$PLAN\_HISTORY

The V\$PLAN\_HISTORY displays information of SQL plans.

**Table 9-237** Column information

| Column name       | Data type                      | Description                                      |
|-------------------|--------------------------------|--------------------------------------------------|
| DRIVER_MEMBER_POS | NUMBER                         | driver member position                           |
| DRIVER_SESSION_ID | NUMBER                         | driver session identifier                        |
| SESSION_ID        | NUMBER                         | session identifier                               |
| STMT_ID           | NUMBER                         | statement identifier in a session                |
| CL_STMT_ID        | NUMBER                         | cluster statement identifier in a session        |
| DRIVER_CL_STMT_ID | NUMBER                         | driver cluster statement identifier in a session |
| PLAN_HISTORY_POS  | NUMBER                         | plan history position                            |
| PLAN_HISTORY_ID   | NUMBER                         | plan history identifier                          |
| SQL_TEXT          | LONG VARCHAR                   | SQL text for the statement                       |
| PLAN_TEXT         | LONG VARCHAR                   | plan text for the statement                      |
| LAST_EXEC_TIME    | TIMESTAMP(2) WITHOUT TIME ZONE | statement last execution time                    |

## V\$PLAN\_HISTORY\_LATEST

The V\$PLAN\_HISTORY\_LATEST displays information of the latest SQL plan.

**Table 9-238** Column information

| Column name       | Data type                      | Description                                      |
|-------------------|--------------------------------|--------------------------------------------------|
| DRIVER_MEMBER_POS | NUMBER                         | driver member position                           |
| DRIVER_SESSION_ID | NUMBER                         | driver session identifier                        |
| SESSION_ID        | NUMBER                         | session identifier                               |
| STMT_ID           | NUMBER                         | statement identifier in a session                |
| CL_STMT_ID        | NUMBER                         | cluster statement identifier in a session        |
| DRIVER_CL_STMT_ID | NUMBER                         | driver cluster statement identifier in a session |
| PLAN_HISTORY_POS  | NUMBER                         | plan history position                            |
| PLAN_HISTORY_ID   | NUMBER                         | plan history identifier                          |
| SQL_TEXT          | LONG VARCHAR                   | SQL text for the statement                       |
| PLAN_TEXT         | LONG VARCHAR                   | plan text for the statement                      |
| LAST_EXEC_TIME    | TIMESTAMP(2) WITHOUT TIME ZONE | statement last execution time                    |

## V\$PROCESS\_STAT

The V\$PROCESS\_STAT displays goldilocks process statistics.

**Table 9-239** Column information

| Column name | Data type    | Description                   |
|-------------|--------------|-------------------------------|
| STAT_NAME   | VARCHAR(128) | statistic name                |
| PROC_ID     | NUMBER       | goldilocks process identifier |
| STAT_VALUE  | NUMBER       | statistic value               |



## V\$PROCESS\_MEM\_STAT

The V\$PROCESS\_MEM\_STAT displays goldilocks process memory statistics.

**Table 9-240** Column information

| Column name | Data type    | Description                   |
|-------------|--------------|-------------------------------|
| STAT_NAME   | VARCHAR(128) | statistic name                |
| PROC_ID     | NUMBER       | goldilocks process identifier |
| STAT_VALUE  | NUMBER       | statistic value               |

## V\$PROCESS\_SQL\_STAT

The V\$PROCESS\_SQL\_STAT displays goldilocks process SQL statistics.

**Table 9-241** Column information

| Column name | Data type    | Description                   |
|-------------|--------------|-------------------------------|
| STAT_NAME   | VARCHAR(128) | statistic name                |
| PROC_ID     | NUMBER       | goldilocks process identifier |
| STAT_VALUE  | NUMBER       | statistic value               |

## V\$PROPERTY

The V\$PROPERTY displays a list of all properties at current session. Otherwise, the instance-wide value.

**Table 9-242** Column information

| Column name     | Data type     | Description                                                                                                                   |
|-----------------|---------------|-------------------------------------------------------------------------------------------------------------------------------|
| PROPERTY_NAME   | VARCHAR(128)  | name of the property                                                                                                          |
| DESCRIPTION     | VARCHAR(2048) | description of the property                                                                                                   |
| DATA_TYPE       | VARCHAR(32)   | data type of the property                                                                                                     |
| STARTUP_PHASE   | VARCHAR(32)   | modifiable startup-phase: the value IN ( NO MOUNT / MOUNT / OPEN & [BELOW ABOVE] )                                            |
| VALUE_UNIT      | VARCHAR(32)   | unit of the property value: the value in ( NONE, BYTE, MS(milisc) )                                                           |
| PROPERTY_VALUE  | VARCHAR(2048) | property value for the session. otherwise, the instance-wide value                                                            |
| PROPERTY_SOURCE | VARCHAR(32)   | source of the current property value: the value IN ( USER, DEFAULT, ENV_VAR, BINARY_FILE, FILE, SYSTEM )                      |
| INIT_VALUE      | VARCHAR(2048) | property init value for the session                                                                                           |
| INIT_SOURCE     | VARCHAR(32)   | source of the current property INIT_VALUE: the value IN ( USER, DEFAULT, ENV_VAR, BINARY_FILE, FILE, SYSTEM )                 |
| MIN_VALUE       | NUMBER        | minimum value for property. null if type is varchar                                                                           |
| MAX_VALUE       | NUMBER        | maximum value for property. null if type is varchar                                                                           |
| SES_MODIFIABLE  | VARCHAR(32)   | property can be changed with ALTER SESSION or not: the value in ( TRUE, FALSE )                                               |
| SYS_MODIFIABLE  | VARCHAR(32)   | property can be changed with ALTER SYSTEM and when the change takes effect: the value in ( NONE, FALSE, IMMEDIATE, DEFERRED ) |
| IS_MODIFIABLE   | VARCHAR(32)   | property can be changed or not: the value in ( TRUE, FALSE )                                                                  |
| IS_DEPRECATED   | VARCHAR(32)   | whether a property is deprecated or not: the value in (TRUE, FALSE)                                                           |
| IS_GLOBAL       | VARCHAR(32)   | whether a property scope is global or not: the value in (TRUE, FALSE)                                                         |

## V\$PSM\_RESERVED\_WORDS

The V\$PSM\_RESERVED\_WORDS displays a list of all PSM reserved keywords. Reserved words cannot be used in variable name or procedure name.

**Table 9-243** Column information

| Column name    | Data type    | Description           |
|----------------|--------------|-----------------------|
| KEYWORD_NAME   | VARCHAR(128) | name of keyword       |
| KEYWORD_LENGTH | NUMBER       | length of the keyword |

# V\$QUEUE

The V\$QUEUE displays information of queue.

**Table 9-244** Column information

| Column name | Data type    | Description                                                        |
|-------------|--------------|--------------------------------------------------------------------|
| TYPE        | NUMBER       | queue type ( COMMON or DISPATCHER )                                |
| INDEX       | NUMBER       | index                                                              |
| QUEUED      | NUMBER       | number of items in the queue                                       |
| WAIT        | NUMBER       | total time that all items in this queue have waited (1/100 second) |
| TOTALQ      | VARCHAR(128) | total number of items that have ever been in the queue             |

## V\$RESERVED\_WORDS

The V\$RESERVED\_WORDS displays a list of all SQL reserved keywords. Reserved words cannot be used in table name or column name.

**Table 9-245** Column information

| Column name    | Data type    | Description           |
|----------------|--------------|-----------------------|
| KEYWORD_NAME   | VARCHAR(128) | name of keyword       |
| KEYWORD_LENGTH | NUMBER       | length of the keyword |

## V\$SEQUENCE

The V\$SEQUENCE displays information of sequences

**Table 9-246** Column information

| Column name                     | Data type                          | Description                                                                                     |
|---------------------------------|------------------------------------|-------------------------------------------------------------------------------------------------|
| SEQUENCE_NAME                   | VARCHAR(128)                       | sequence name                                                                                   |
| PHYSICAL_ID                     | NUMBER                             | sequence physical identifier                                                                    |
| START_WITH                      | NUMBER                             | start with value                                                                                |
| INCREMENT_BY                    | NUMBER                             | increment value                                                                                 |
| MAXVALUE                        | NUMBER                             | maximum value                                                                                   |
| MINVALUE                        | NUMBER                             | minimum value                                                                                   |
| CACHE_SIZE                      | NUMBER                             | cache size                                                                                      |
| LOCAL_NEXT_VALUE                | NUMBER                             | local next value                                                                                |
| LOCAL_CURR_VALU<br>E            | NUMBER                             | local current value                                                                             |
| RESTART_VALUE                   | NUMBER                             | restart value                                                                                   |
| CYCLE                           | BOOLEAN                            | allow cycle                                                                                     |
| USE_LAST_VALUE                  | BOOLEAN                            | use last value or not                                                                           |
| LOCAL_CACHE_COU<br>NT           | NUMBER                             | current local cache count                                                                       |
| GLOBAL_NEXT_VAL<br>UE           | NUMBER                             | global next cache chunk start value                                                             |
| SYNC_COMPARE_SN                 | NUMBER                             | serial number for global sequence synchronization                                               |
| GLOBAL_LATCH_SES<br>SION_ID     | NUMBER                             | identifier of the session acquiring the global latch ( -1 if the latch is not acquired )        |
| GLOBAL_LATCH_SES<br>SION_SERIAL | NUMBER                             | serial number of the session acquiring the global latch ( -1 if the latc<br>h is not acquired ) |
| DDL_LATCH_SESSIO<br>N_ID        | NUMBER                             | identifier of the session acquiring the ddl latch ( -1 if the latch is not<br>acquired )        |
| DDL_LATCH_SESSIO<br>N_SERIAL    | NUMBER                             | serial number of the session acquiring the ddl latch ( -1 if the latch is<br>not acquired )     |
| LOCAL_LATCH_SESSI<br>ON_ID      | NUMBER                             | identifier of the session acquiring the local latch ( -1 if the latch is no<br>t acquired )     |
| LOCAL_LATCH_SESSI<br>ON_SERIAL  | NUMBER                             | serial number of the session acquiring the local latch ( -1 if the latch<br>is not acquired )   |
| IS_ONLINE                       | BOOLEAN                            | is online                                                                                       |
| LAST_SYNC_TIME                  | TIMESTAMP(2) WITH<br>OUT TIME ZONE | last time the sequence was synchronized                                                         |

## V\$SESSION

The V\$SESSION displays session information for each current session.

**Table 9-247** Column information

| Column name     | Data type                          | Description                                                                                                              |
|-----------------|------------------------------------|--------------------------------------------------------------------------------------------------------------------------|
| SESSION_ID      | NUMBER                             | session identifier                                                                                                       |
| SERIAL_NO       | NUMBER                             | session serial number                                                                                                    |
| TRANS_ID        | NUMBER                             | transaction identifier ( -1 if inactive transaction )                                                                    |
| CONNECTION_TYPE | VARCHAR(32)                        | connection type: the value in ( DA, TCP )                                                                                |
| USER_NAME       | VARCHAR(128)                       | user name                                                                                                                |
| SESSION_STATUS  | VARCHAR(32)                        | status of the session: the value in ( CONNECTED, SIGNALED, SNIPED, DEAD )                                                |
| SERVER_TYPE     | VARCHAR(32)                        | server type: the value in ( DEDICATED, SHARED )                                                                          |
| PROCESS_ID      | NUMBER                             | client process identifier                                                                                                |
| LOGON_TIME      | TIMESTAMP(2) WITH<br>OUT TIME ZONE | logon time                                                                                                               |
| PROGRAM_NAME    | VARCHAR(128)                       | program name                                                                                                             |
| CLIENT_ADDRESS  | VARCHAR(1024)                      | client address ( null if DA )                                                                                            |
| CLIENT_PORT     | NUMBER                             | client port ( 0 if DA )                                                                                                  |
| FAILOVER_TYPE   | VARCHAR(13)                        | indicates whether and to what extent transparent application failover (TAF) is enabled for the session ( NONE, SESSION ) |
| FAILED_OVER     | VARCHAR(3)                         | indicates whether the session is running in failover mode and failover has occurred (YES) or not (NO)                    |
| IS_AUDITED      | VARCHAR(3)                         | indicates whether the session is audited (YES) or not (NO)                                                               |



## V\$SESSION\_AUDIT

The V\$SESSION\_AUDIT displays audited session information.

**Table 9-248** Column information

| Column name  | Data type    | Description                                                                          |
|--------------|--------------|--------------------------------------------------------------------------------------|
| SESSION_ID   | NUMBER       | session identifier                                                                   |
| SERIAL_NO    | NUMBER       | session serial number                                                                |
| POLICY_NAME  | VARCHAR(128) | active audit policy name                                                             |
| WHEN_SUCCESS | VARCHAR(3)   | indicates whether the audit policy is enable for auditing successful events or not   |
| WHEN_FAILURE | VARCHAR(3)   | indicates whether the audit policy is enable for auditing unsuccessful events or not |

## V\$SESSION\_CONNECT\_INFO

The V\$SESSION\_CONNECT\_INFO displays information about network connections for the current session.

**Table 9-249** Column information

| Column name    | Data type   | Description           |
|----------------|-------------|-----------------------|
| SESSION_ID     | NUMBER      | session identifier    |
| SERIAL_NO      | NUMBER      | session serial number |
| CLIENT_CHARSET | VARCHAR(40) | client character set  |

## V\$SESSION\_EVENT

The V\$SESSION\_EVENT displays information on waits for an event by a session.

**Table 9-250** Column information

| Column name     | Data type   | Description                                                    |
|-----------------|-------------|----------------------------------------------------------------|
| SESSION_ID      | NUMBER      | ID of the session                                              |
| WAIT_EVENT_ID   | NUMBER      | Identifier of the wait event                                   |
| WAIT_EVENT_NAME | VARCHAR(64) | Name of the wait event                                         |
| TOTAL_WAITS     | NUMBER      | Total number of waits for the event                            |
| TOTAL_TIMEOUTS  | NUMBER      | Total number of timeouts for the event                         |
| TIME_WAITED     | NUMBER      | Total amount of time waited for the event (microsecond)        |
| AVERAGE_WAIT    | NUMBER      | Average amount of time waited for the event (microsecond)      |
| MAX_WAIT        | NUMBER      | Maximum time waited for the event by the session (microsecond) |
| CLASS_NAME      | VARCHAR(64) | Name of the class of the wait event                            |

## V\$SESSION\_STAT

The V\$SESSION\_STAT displays session statistics.

**Table 9-251** Column information

| Column name | Data type    | Description        |
|-------------|--------------|--------------------|
| STAT_NAME   | VARCHAR(128) | statistic name     |
| SESS_ID     | NUMBER       | session identifier |
| STAT_VALUE  | NUMBER       | statistic value    |

## V\$SESSION\_MEM\_STAT

The V\$SESSION\_MEM\_STAT displays session memory statistics.

**Table 9-252** Column information

| Column name | Data type    | Description        |
|-------------|--------------|--------------------|
| STAT_NAME   | VARCHAR(128) | statistic name     |
| SESS_ID     | NUMBER       | session identifier |
| STAT_VALUE  | NUMBER       | statistic value    |

## V\$SESSION\_MEM\_USAGE

The V\$SESSION\_MEM\_USAGE displays session memory usage for each session.

**Table 9-253** Column information

| Column name    | Data type  | Description                                 |
|----------------|------------|---------------------------------------------|
| SESSION_ID     | NUMBER     | session identifier                          |
| ALLOCATOR_ID   | NUMBER     | memory allocator identifier                 |
| ALLOCATOR_TYPE | VARCHAR(7) | memory allocator type ( REGION or DYNAMIC ) |
| MEMORY_TYPE    | VARCHAR(4) | memory type ( HEAP, SHM )                   |
| TOTAL_SIZE     | NUMBER     | total memory size                           |

## V\$SESSION\_SQL\_STAT

The V\$SESSION\_SQL\_STAT displays session SQL statistics.

**Table 9-254** Column information

| Column name | Data type    | Description        |
|-------------|--------------|--------------------|
| STAT_NAME   | VARCHAR(128) | statistic name     |
| SESS_ID     | NUMBER       | session identifier |
| STAT_VALUE  | NUMBER       | statistic value    |

## V\$SESSION\_WAIT

The V\$SESSION\_WAIT displays the current or last wait for each session.

**Table 9-255** Column information

| Column name          | Data type   | Description                                                                                                                                                                                 |
|----------------------|-------------|---------------------------------------------------------------------------------------------------------------------------------------------------------------------------------------------|
| SESSION_ID           | NUMBER      | ID of the session                                                                                                                                                                           |
| SEQ_NO               | NUMBER      | Identifier of the wait event                                                                                                                                                                |
| WAIT_EVENT_ID        | NUMBER      | Name of the wait event                                                                                                                                                                      |
| WAIT_EVENT_NAME      | VARCHAR(64) | A number that uniquely identifies the current or last wait (incremented for each wait)                                                                                                      |
| P1TEXT               | VARCHAR(64) | Description of the first parameter for the wait event                                                                                                                                       |
| P1                   | NUMBER      | First wait event parameter (in decimal)                                                                                                                                                     |
| P1HEX                | VARCHAR(32) | First wait event parameter (in hex)                                                                                                                                                         |
| P2TEXT               | VARCHAR(64) | Description of the second parameter for the wait event                                                                                                                                      |
| P2                   | NUMBER      | Second wait event parameter (in decimal)                                                                                                                                                    |
| P2HEX                | VARCHAR(32) | Second wait event parameter (in hex)                                                                                                                                                        |
| P3TEXT               | VARCHAR(64) | Description of the third parameter for the wait event                                                                                                                                       |
| P3                   | NUMBER      | Third wait event parameter (in decimal)                                                                                                                                                     |
| P3HEX                | VARCHAR(32) | Third wait event parameter (in hex)                                                                                                                                                         |
| STATE                | VARCHAR(64) | Wait state                                                                                                                                                                                  |
| WAIT_TIME            | NUMBER      | If the session is currently waiting, then the value is time waited for the current wait. If the session is not in a wait, then the value is the duration of the last wait (in microseconds) |
| TIME_SINCE_LAST_WAIT | NUMBER      | Time elapsed since the end of the last wait (in microseconds). If the session is currently in a wait, then the value is 0.                                                                  |
| CLASS_NAME           | VARCHAR(64) | Name of the class of the wait event                                                                                                                                                         |



## V\$SHARED\_MODE

The V\$SHARED\_MODE displays information of shared mode.

**Table 9-256** Column information

| Column name | Data type    | Description |
|-------------|--------------|-------------|
| NAME        | VARCHAR(128) | name        |
| VALUE       | VARCHAR(128) | value       |

## V\$SHARED\_SERVER

The V\$SHARED\_SERVER displays information of shared servers.

**Table 9-257** Column information

| Column name         | Data type    | Description                      |
|---------------------|--------------|----------------------------------|
| PROCESS_ID          | NUMBER       | shared server process identifier |
| PROCESSED_JOB_COUNT | NUMBER       | processed job count              |
| STATUS              | VARCHAR(128) | status                           |
| IDLE                | NUMBER       | total idle time (1/100 second)   |
| BUSY                | NUMBER       | total busy time (1/100 second)   |

## V\$SHM\_SEGMENT

The V\$SHM\_SEGMENT displays a list of all shared memory segments.

**Table 9-258** Column information

| Column name | Data type   | Description                                                 |
|-------------|-------------|-------------------------------------------------------------|
| SHM_NAME    | VARCHAR(32) | shared memory segment name                                  |
| SHM_ID      | NUMBER      | shared memory segment identifier                            |
| SHM_SIZE    | NUMBER      | shared memory segment size ( in bytes )                     |
| SHM_KEY     | NUMBER      | shared memory segment key                                   |
| SHM_SEQ     | NUMBER      | shared memory segment sequence                              |
| SHM_ADDR    | VARCHAR(32) | start address of the shared memory segment                  |
| LARGE_PAGES | BOOLEAN     | indicates whether the shared memory segment use large pages |

## V\$SPROPERTY

The V\$SPROPERTY displays a list of Properties. This is store a binary property file.

**Table 9-259** Column information

| Column name     | Data type     | Description                                                                                                                   |
|-----------------|---------------|-------------------------------------------------------------------------------------------------------------------------------|
| PROPERTY_NAME   | VARCHAR(128)  | name of the property                                                                                                          |
| DESCRIPTION     | VARCHAR(2048) | description of the property                                                                                                   |
| DATA_TYPE       | VARCHAR(32)   | data type of the property                                                                                                     |
| STARTUP_PHASE   | VARCHAR(32)   | modifiable startup-phase: the value IN ( NO MOUNT / MOUNT / OPEN & [BELOW ABOVE] )                                            |
| VALUE_UNIT      | VARCHAR(32)   | unit of the property value: the value in ( NONE, BYTE, MS(milisc) )                                                           |
| PROPERTY_VALUE  | VARCHAR(2048) | property value stored in the binary property file                                                                             |
| PROPERTY_SOURCE | VARCHAR(32)   | source of the current property value: the value is BINARY_FILE                                                                |
| INIT_VALUE      | VARCHAR(2048) | property init value for the system                                                                                            |
| INIT_SOURCE     | VARCHAR(32)   | source of the current property INIT_VALUE: the value IN ( USER, DEFAULT, ENV_VAR, BINARY_FILE, FILE, SYSTEM )                 |
| MIN_VALUE       | NUMBER        | minimum value for property. null if type is varchar                                                                           |
| MAX_VALUE       | NUMBER        | maximum value for property. null if type is varchar                                                                           |
| SES_MODIFIABLE  | VARCHAR(32)   | property can be changed with ALTER SESSION or not: the value in ( TRUE, FALSE )                                               |
| SYS_MODIFIABLE  | VARCHAR(32)   | property can be changed with ALTER SYSTEM and when the change takes effect: the value in ( NONE, FALSE, IMMEDIATE, DEFERRED ) |
| IS_MODIFIABLE   | VARCHAR(32)   | property can be changed or not: the value in ( TRUE, FALSE )                                                                  |

## V\$SQLFN\_METADATA

The V\$SQLFN\_METADATA contains metadata about operators and built-in functions

**Table 9-260** Column information

| Column name  | Data type    | Description                                                                   |
|--------------|--------------|-------------------------------------------------------------------------------|
| FUNC_NAME    | VARCHAR(128) | name of the built-in function                                                 |
| MINARGS      | NUMBER       | minimum number of arguments for the function                                  |
| MAXARGS      | NUMBER       | maximum number of arguments for the function                                  |
| IS_AGGREGATE | BOOLEAN      | indicates whether the function is an aggregate function (TRUE) or not (FALSE) |

## V\$SQL\_CACHE

The V\$SQL\_CACHE lists statistics of shared SQL plan.

**Table 9-261** Column information

| Column name      | Data type    | Description                                            |
|------------------|--------------|--------------------------------------------------------|
| SQL_HANDLE       | NUMBER       | SQL handle                                             |
| HASH_VALUE       | NUMBER       | hash value of the SQL statement                        |
| REF_COUNT        | NUMBER       | count of prepared statements referencing the statement |
| PLAN_SIZE        | NUMBER       | the total plan size of the SQL statement ( in bytes )  |
| CLOCK_ID         | NUMBER       | clock identifier                                       |
| PLAN_AGE         | NUMBER       | plan age                                               |
| USER_NAME        | VARCHAR(128) | user name                                              |
| BIND_PARAM_COUNT | NUMBER       | count of bind parameters                               |
| SQL_TEXT         | LONG VARCHAR | SQL full text                                          |
| PLAN_COUNT       | NUMBER       | physical plan count of the SQL statement               |
| PLAN_ID          | NUMBER       | plan identifier                                        |
| PLAN_SIZE        | NUMBER       | the total plan size of the SQL statement ( in bytes )  |
| PLAN_IS_ATOMIC   | BOOLEAN      | plan is atomic array insert or not                     |
| PLAN_TEXT        | LONG VARCHAR | plan text for SQL statement                            |

## V\$SQL\_COMMAND

The V\$SQL\_COMMAND lists attribute information of each SQL command.

**Table 9-262** Column information

| Column name       | Data type    | Description                                                             |
|-------------------|--------------|-------------------------------------------------------------------------|
| COMMAND           | VARCHAR(128) | SQL command                                                             |
| FROM_PHASE        | VARCHAR(32)  | executable from start-up phase                                          |
| UNTIL_PHASE       | VARCHAR(32)  | executable until start-up phase                                         |
| ACCESS_MODE       | VARCHAR(32)  | database access mode: values in (NONE, READ & WRITE, READ, READ & LOCK) |
| NEED_FETCH        | VARCHAR(32)  | the command is a query which has result set and need fetch              |
| IS_DDL            | VARCHAR(3)   | the command is a DDL(Data Defintion Language) or not                    |
| CLUSTER_LOCK_MODE | VARCHAR(32)  | cluster lock mode: values in (NONE, SERIAL, MANUAL)                     |
| AUTO_COMMIT       | VARCHAR(3)   | the command is auto-commit or not                                       |
| IS_CACHEABLE      | VARCHAR(3)   | the command is plan-cacheable or not                                    |
| AUDIT_ACTION      | VARCHAR(128) | auditable action name for the SQL command                               |

## V\$SQL\_HISTORY

The V\$SQL\_HISTORY displays information of SQLs.

**Table 9-263** Column information

| Column name       | Data type                      | Description                                                       |
|-------------------|--------------------------------|-------------------------------------------------------------------|
| DRIVER_MEMBER_POS | NUMBER                         | driver member position                                            |
| SESSION_ID        | NUMBER                         | session identifier                                                |
| START_TIME        | TIMESTAMP(2) WITHOUT TIME ZONE | statement start time                                              |
| EXEC_TIME         | NUMBER                         | execution time(us)                                                |
| PREPARED          | BOOLEAN                        | indicates whether the statement is prepared ( YES ) or not ( NO ) |
| SUCCESS           | BOOLEAN                        | indicates whether the statement is success ( YES ) or not ( NO )  |
| STATUS            | CHARACTER VARYING(16)          | status of the statement: the value in ( RUNNING, DONE )           |
| SQL_TEXT          | CHARACTER VARYING(1024 )       | first 1024 bytes of the SQL text for the statement                |



## V\$STATEMENT

The V\$STATEMENT lists all statements.

**Table 9-264** Column information

| Column name     | Data type                      | Description                                        |
|-----------------|--------------------------------|----------------------------------------------------|
| SESSION_ID      | NUMBER                         | session identifier                                 |
| STMT_ID         | NUMBER                         | statement identifier in a session                  |
| STMT_VIEW_SCN   | NUMBER                         | statement view scn                                 |
| SQL_TEXT        | VARCHAR(1024)                  | first 1024 bytes of the SQL text for the statement |
| START_TIME      | TIMESTAMP(2) WITHOUT TIME ZONE | statement start time                               |
| TOTAL_EXEC_TIME | NATIVE_BIGINT                  | total execution time(us)                           |
| LAST_EXEC_TIME  | NATIVE_BIGINT                  | last execution time(us)                            |
| EXECUTIONS      | NATIVE_BIGINT                  | number of executions                               |

## V\$SYSTEM\_EVENT

The V\$SYSTEM\_EVENT displays information on total waits for an event.

**Table 9-265** Column information

| Column name     | Data type   | Description                                               |
|-----------------|-------------|-----------------------------------------------------------|
| WAIT_EVENT_ID   | NUMBER      | Identifier of the wait event                              |
| WAIT_EVENT_NAME | VARCHAR(64) | Name of the wait event                                    |
| TOTAL_WAITS     | NUMBER      | Total number of waits for the event                       |
| TOTAL_TIMEOUTS  | NUMBER      | Total number of timeouts for the event                    |
| TIME_WAITED     | NUMBER      | Total amount of time waited for the event (microsecond)   |
| AVERAGE_WAIT    | NUMBER      | Average amount of time waited for the event (microsecond) |
| CLASS_NAME      | VARCHAR(64) | Name of the class of the wait event                       |

## V\$SYSTEM\_STAT

The V\$SYSTEM\_STAT displays system statistics.

**Table 9-266** Column information

| Column name | Data type     | Description     |
|-------------|---------------|-----------------|
| STAT_NAME   | VARCHAR(128)  | statistic name  |
| STAT_VALUE  | NUMBER        | statistic value |
| COMMENTS    | VARCHAR(1024) | comments        |

## V\$SYSTEM\_MEM\_STAT

The V\$SYSTEM\_MEM\_STAT displays system memory statistics.

**Table 9-267** Column information

| Column name | Data type     | Description     |
|-------------|---------------|-----------------|
| STAT_NAME   | VARCHAR(128)  | statistic name  |
| STAT_VALUE  | NUMBER        | statistic value |
| COMMENTS    | VARCHAR(1024) | comments        |

## V\$SYSTEM\_SQL\_STAT

The V\$SYSTEM\_SQL\_STAT displays system SQL statistics.

**Table 9-268** Column information

| Column name | Data type     | Description     |
|-------------|---------------|-----------------|
| STAT_NAME   | VARCHAR(128)  | statistic name  |
| STAT_VALUE  | NUMBER        | statistic value |
| COMMENTS    | VARCHAR(1024) | comments        |

## V\$TABLES

The V\$TABLES contains the definitions of all the performance views (views beginning with V\$).

**Table 9-269** Column information

| Column name   | Data type                      | Description                                                                                                          |
|---------------|--------------------------------|----------------------------------------------------------------------------------------------------------------------|
| TABLE_OWNER   | VARCHAR(128)                   | owner name who owns the performance view                                                                             |
| TABLE_SCHEMA  | VARCHAR(128)                   | schema name of the performance view                                                                                  |
| TABLE_NAME    | VARCHAR(128)                   | name of the performance view                                                                                         |
| STARTUP_PHASE | VARCHAR(32)                    | visible startup phase of the performance view                                                                        |
| CREATED_TIME  | TIMESTAMP(2) WITHOUT TIME ZONE | <ul style="list-style-type: none"> <li>available only in OPEN phase</li> </ul> created time of the performance view  |
| MODIFIED_TIME | TIMESTAMP(2) WITHOUT TIME ZONE | <ul style="list-style-type: none"> <li>available only in OPEN phase</li> </ul> modified time of the performance view |
| COMMENTS      | VARCHAR(1024)                  | <ul style="list-style-type: none"> <li>available only in OPEN phase</li> </ul> comments of the performance view      |

## V\$TABLESPACE

This view displays tablespace information.

**Table 9-270** Column information

| Column name   | Data type    | Description                                                                                                                                                   |
|---------------|--------------|---------------------------------------------------------------------------------------------------------------------------------------------------------------|
| TBS_NAME      | VARCHAR(128) | tablespace name                                                                                                                                               |
| TBS_ID        | NUMBER       | tablespace identifier                                                                                                                                         |
| TBS_ATTR      | VARCHAR(128) | tablespace attribute: the value in ( device attribute (MEMORY)   temporary attribute (TEMPORARY, PERSISTENT)   usage attribute(DICT, UNDO, DATA, TEMPORARY) ) |
| IS_LOGGING    | BOOLEAN      | indicates whether the tablespace is a logging tablespace ( YES ) or not ( NO )                                                                                |
| IS_ONLINE     | BOOLEAN      | indicates whether the tablespace is ONLINE ( YES ) or OFFLINE ( NO )                                                                                          |
| OFFLINE_STATE | VARCHAR(32)  | indicates whether the tablespace can be taken online normally ( CONSISTENT ) or not ( INCONSISTENT ). null if the tablespace is ONLINE                        |
| EXTENT_SIZE   | NUMBER       | extent size of the tablespace ( in bytes )                                                                                                                    |
| PAGE_SIZE     | NUMBER       | page size of the tablespace ( in bytes )                                                                                                                      |

## V\$TABLESPACE\_STAT

This view displays tablespace statistical information.

**Table 9-271** Column information

| Column name         | Data type    | Description                                        |
|---------------------|--------------|----------------------------------------------------|
| TBS_NAME            | VARCHAR(128) | tablespace name                                    |
| TBS_ID              | NUMBER       | tablespace identifier                              |
| TOTAL_EXT_COUNT     | NUMBER       | total extent count of the tablespace               |
| USED_META_EXT_COUNT | NUMBER       | meta extent count currently used on the tablespace |
| USED_DATA_EXT_COUNT | NUMBER       | data extent count currently used on the tablespace |
| FREE_EXT_COUNT      | NUMBER       | free extent count of the tablespace                |
| EXTENT_SIZE         | NUMBER       | extent size of the tablespace ( in bytes )         |



## V\$TRANSACTION

The V\$TRANSACTION lists the active transactions in the system.

**Table 9-272** Column information

| Column name       | Data type                          | Description                                                                                   |
|-------------------|------------------------------------|-----------------------------------------------------------------------------------------------|
| TRANS_ID          | NUMBER                             | transaction identifier                                                                        |
| SESSION_ID        | NUMBER                             | session identifier ( null if the global transaction is unassociated                           |
| TRANS_SLOT_ID     | NUMBER                             | transaction slot identifier                                                                   |
| PHYSICAL_TRANS_ID | NUMBER                             | physical transaction identifier                                                               |
| TRANS_STATE       | VARCHAR(32)                        | transaction state: the value in ( ACTIVE, BLOCK, PREPARE, COMMIT, ROLLBACK, IDLE, PRECOMMIT ) |
| IS_GLOBAL         | BOOLEAN                            | indicates whether the transaction is global or not                                            |
| TRANS_ATTRIBUTE   | VARCHAR(32)                        | transaction attribute: the value in ( READ_ONLY, UPDATABLE, LOCKABLE, UPDATABLE   LOCKABLE )  |
| ISOLATION_LEVEL   | VARCHAR(32)                        | transaction isolation level: the value in ( READ COMMITTED, SERIALI ZABLE )                   |
| TRANS_VIEW_SCN    | NUMBER                             | transaction view scn                                                                          |
| TCN               | NUMBER                             | transaction change number                                                                     |
| TRANS_SEQ         | NUMBER                             | transaction sequence number                                                                   |
| START_TIME        | TIMESTAMP(2) WITH<br>OUT TIME ZONE | transaction start time                                                                        |

## V\$WAIT\_EVENT\_CLASS\_NAME

The V\$WAIT\_EVENT\_CLASS\_NAME displays information about Class of wait event.

**Table 9-273** Column information

| Column name | Data type    | Description                                |
|-------------|--------------|--------------------------------------------|
| CLASS_ID    | NUMBER       | Identifier of the class of the wait event  |
| NAME        | VARCHAR(64)  | Name of the class of the wait event        |
| DESCRIPTION | VARCHAR(128) | Description of the class of the wait event |

## V\$WAIT\_EVENT\_NAME

The V\$WAIT\_EVENT\_NAME displays information about wait events.

**Table 9-274** Column information

| Column name | Data type    | Description                                            |
|-------------|--------------|--------------------------------------------------------|
| CLASS_ID    | NUMBER       | Identifier of the wait event                           |
| NAME        | VARCHAR(64)  | Name of the wait event                                 |
| DESCRIPTION | VARCHAR(128) | Description of the wait event                          |
| PARAMETER1  | NUMBER       | Description of the first parameter for the wait event  |
| PARAMETER1  | NUMBER       | Description of the second parameter for the wait event |
| PARAMETER1  | NUMBER       | Description of the third parameter for the wait event  |
| CLASS_ID    | NUMBER       | Identifier of the class of the wait event              |
| CLASS_NAME  | VARCHAR(64)  | Name of the class of the wait event                    |

## V\$XA\_TRANSACTION

The V\$XA\_TRANSACTION displays information on the currently active XA transactions.

**Table 9-275** Column information

| Column name     | Data type                          | Description                                                                                                    |
|-----------------|------------------------------------|----------------------------------------------------------------------------------------------------------------|
| XA_TRANS_ID     | VARCHAR(1024)                      | XA transaction identifier                                                                                      |
| LOCAL_TRANS_ID  | NUMBER                             | local transaction identifier                                                                                   |
| XA_TRANS_STATE  | VARCHAR(32)                        | state of the XA transaction: the value in ( NOTR, ACTIVE, IDLE, PREPARED, ROLLBACK_ONLY, HEURISTIC_COMPLETED ) |
| ASSO_STATE      | VARCHAR(32)                        | associate state of the XA transaction: the value in ( NOT_ASSOCIATED, ASSOCIATED, ASSOCIATION_SUSPENDED )      |
| START_TIME      | TIMESTAMP(2) WITH<br>OUT TIME ZONE | XA transaction start time                                                                                      |
| IS_REPREPARABLE | BOOLEAN                            | indicates whether the XA transaction is reparable                                                              |

**10.**

---

## **Server Property**

## 10.1 Server Property Information

For more information about SQL syntax to change properties, refer to the followings.

- **ALTER SYSTEM SET `property_name`**
- **ALTER SESSION SET `property_name`**

For more information about property types, refer to the followings.

- **V\$PROPERTY**
- **V\$SPROPERTY**

The followings describe basic information items of property in this manual.

| Item             | Description                                                                                                                                                                                                                                                                                                                                                                                                                                                                                                                                                                                                                                                             |
|------------------|-------------------------------------------------------------------------------------------------------------------------------------------------------------------------------------------------------------------------------------------------------------------------------------------------------------------------------------------------------------------------------------------------------------------------------------------------------------------------------------------------------------------------------------------------------------------------------------------------------------------------------------------------------------------------|
| Name             | Property name                                                                                                                                                                                                                                                                                                                                                                                                                                                                                                                                                                                                                                                           |
| Summary          | Short description of the property                                                                                                                                                                                                                                                                                                                                                                                                                                                                                                                                                                                                                                       |
| Data type        | Data type of the property value                                                                                                                                                                                                                                                                                                                                                                                                                                                                                                                                                                                                                                         |
| Applicable phase | A startup phase which can be updated with ALTER SYSTEM or ALTER SESSION <ul style="list-style-type: none"> <li>• NONE: Applicable phase does not exist. (If it can be updated, but applicable phase is NONE, then use <i>SCOPE = FILE</i> option.)</li> </ul>                                                                                                                                                                                                                                                                                                                                                                                                           |
| Updatable        | Whether property is updatable or not <ul style="list-style-type: none"> <li>• If the property value is TRUE, it is updatable.</li> <li>• If the property value is FALSE, only the read-only is possible.</li> </ul>                                                                                                                                                                                                                                                                                                                                                                                                                                                     |
| ALTER SESSION    | Whether property is updatable or not by using <b>ALTER SESSION SET <code>property_name</code></b>                                                                                                                                                                                                                                                                                                                                                                                                                                                                                                                                                                       |
| ALTER SYSTEM     | Whether property is updatable or not by using <b>ALTER SYSTEM SET <code>property_name</code></b> <ul style="list-style-type: none"> <li>• IMMEDIATE: The updated value is immediately reflected in all session after execution.</li> <li>• DEFERRED: The updated value is reflected only in the session which is connected after execution. However, it is not reflected in already connected session.</li> <li>• FALSE: The updated value is not reflected in the session during execution. However, the updated value is reflected after restart, (Properties are updatable by using only <i>SCOPE=FILE</i> option.)</li> <li>• NONE: It is not updatable.</li> </ul> |
| MIN              | If the data type is BIGINT, it is the minimum value of property.<br>If the data type is VARCHAR, the minimum value of property is N/A.                                                                                                                                                                                                                                                                                                                                                                                                                                                                                                                                  |
| MAX              | If the data type is BIGINT, it is the maximum value of property.<br>If the data type is VARCHAR, the maximum value of property is N/A.                                                                                                                                                                                                                                                                                                                                                                                                                                                                                                                                  |
| Default value    | Default value of the property                                                                                                                                                                                                                                                                                                                                                                                                                                                                                                                                                                                                                                           |

## 10.2 AGING\_INTERVAL

### Basic Information

| Item             | Description             |
|------------------|-------------------------|
| Name             | AGING_INTERVAL          |
| Summary          | aging interval time(ms) |
| Data type        | BIGINT                  |
| Applicable phase | NO MOUNT or above       |
| Updatable        | TRUE                    |
| ALTER SESSION    | FALSE                   |
| ALTER SYSTEM     | IMMEDIATE               |
| MIN              | 1                       |
| MAX              | 100000000               |
| Default value    | 10                      |

### Description

It sets the idle time (second) when an ager thread which deletes the previous version data does not have a job to process in MVCC based database.

## 10.3 AGING\_PLAN\_INTERVAL

### Basic Information

| Item             | Description                 |
|------------------|-----------------------------|
| Name             | AGING_PLAN_INTERVAL         |
| Summary          | aging plan interval time(s) |
| Data type        | BIGINT                      |
| Applicable phase | NO MOUNT or above           |
| Updatable        | TRUE                        |
| ALTER SESSION    | FALSE                       |
| ALTER SYSTEM     | IMMEDIATE                   |
| MIN              | 0                           |
| MAX              | 31536000                    |
| Default value    | 0                           |

### Description

The SQL plan which is older than AGING\_PLAN\_INTERVAL becomes the aging target.



## 10.4 ARCHIVELOG\_DIR\_1 ~ ARCHIVELOG\_DIR\_10

### Basic Information

| Item             | Description                                                            |
|------------------|------------------------------------------------------------------------|
| Name             | ARCHIVELOG_DIR_1 ~ ARCHIVELOG_DIR_10                                   |
| Summary          | archive log directory                                                  |
| Data type        | VARCHAR                                                                |
| Applicable phase | NO MOUNT or above                                                      |
| Updatable        | TRUE                                                                   |
| ALTER SESSION    | FALSE(ARCHIVELOG_DIR_1),<br>TRUE(ARCHIVELOG_DIR_2 ~ ARCHIVELOG_DIR_10) |
| ALTER SYSTEM     | DEFERRED                                                               |
| MIN              | N/A                                                                    |
| MAX              | N/A                                                                    |
| Default value    | \$GOLDILOCKS_DATA/archive_log                                          |

### Description

It specifies archiving directory of GOLDILOCKS database's online redo log file. Also, it specifies where to read of archive redo log file at media recovery. The online redo log file creates archive redo log file only in ARCHIVELOG\_DIR\_1.

ARCHIVELOG\_DIR\_1 sets only the system, but ARCHIVELOG\_DIR\_2 ~ ARCHIVELOG\_DIR\_10 sets the session.

## 10.5 ARCHIVELOG\_FILE

### Basic Information

| Item             | Description              |
|------------------|--------------------------|
| Name             | ARCHIVELOG_FILE          |
| Summary          | default archive log file |
| Data type        | VARCHAR                  |
| Applicable phase | MOUNT or below           |
| Updatable        | TRUE                     |
| ALTER SESSION    | FALSE                    |
| ALTER SYSTEM     | DEFERRED                 |
| MIN              | N/A                      |
| MAX              | N/A                      |
| Default value    | archive                  |

### Description

It sets the prefix of the targeted file name stored in the archive directory when archiving the online redo log file. The archive logfile's name consists of the prefix defined in ARCHIVELOG\_FILE, followed by '\_', the file sequence and the file extension 'log'. For example, the online logfile with a sequence number of 0 is archived as 'archive\_0.log'.

## 10.6 ARCHIVELOG\_MODE

### Basic Information

| Item             | Description                           |
|------------------|---------------------------------------|
| Name             | ARCHIVELOG_MODE                       |
| Summary          | archive log mode(0:disable, 1:enable) |
| Data type        | BIGINT                                |
| Applicable phase | NONE                                  |
| Updatable        | FALSE                                 |
| ALTER SESSION    | FALSE                                 |
| ALTER SYSTEM     | FALSE                                 |
| MIN              | 0                                     |
| MAX              | 1                                     |
| Default value    | 0                                     |

### Description

The property is applied at database creation. The archivelog mode can be set to one of the following values.

- 0: NOARCHIVELOG
- 1: ARCHIVELOG

It does not affect archive log mode during operation after database is created. The archive log mode can be modified by using *ALTER DATABASE {ARCHIVELOG | NOARCHIVELOG}* in MOUNT phase.

## 10.7 BACKUP\_DIR\_1 ~ BACKUP\_DIR\_10

### Basic Information

| Item             | Description                                                |
|------------------|------------------------------------------------------------|
| Name             | BACKUP_DIR_1 ~ BACKUP_DIR_10                               |
| Summary          | backup directory                                           |
| Data type        | VARCHAR                                                    |
| Applicable phase | NO MOUNT or above                                          |
| Updatable        | TRUE                                                       |
| ALTER SESSION    | FALSE(BACKUP_DIR_1),<br>TRUE(BACKUP_DIR_2 ~ BACKUP_DIR_10) |
| ALTER SYSTEM     | DEFERRED                                                   |
| MIN              | N/A                                                        |
| MAX              | N/A                                                        |
| Default value    | \$GOLDILOCKS_DATA/backup                                   |

### Description

A backup file is created when incremental backup is executed. Then it sets a directory of backup file to be read when restoring files using incremental backup. Incremental backups are created only in the directory set in BACKUP\_DIR\_1.

BACKUP\_DIR\_1 sets only the system, but BACKUP\_DIR\_2 ~ BACKUP\_DIR\_10 sets the session.

## 10.8 BLOCK\_READ\_COUNT

### Basic Information

| Item             | Description                  |
|------------------|------------------------------|
| Name             | BLOCK_READ_COUNT             |
| Summary          | value count for a block read |
| Data type        | BIGINT                       |
| Applicable phase | NO MOUNT or above            |
| Updatable        | TRUE                         |
| ALTER SESSION    | TRUE                         |
| ALTER SYSTEM     | DEFERRED                     |
| MIN              | 1                            |
| MAX              | 65536                        |
| Default value    | 20                           |

### Description

The SQL executes operation by reading row in the unit of BLOCK\_READ\_COUNT which is a row bundle. BLOCK\_READ\_COUNT means the number of rows to be processed at a time when operation is executed. It is a basic unit of pipe-lining process of execution nodes which are used in SQL query processing.

If BLOCK\_READ\_COUNT value is big the processing performance improves, but many memory resources are used.

The value between 10 and 100 is recommended.

If the value becomes bigger than 100 the resource usage increases proportionately, but the performance improvement does not increase proportionately.

## 10.9 BROADCAST\_INDEX\_REBUILD\_PROTOCOL

### Basic Information

| Item             | Description                      |
|------------------|----------------------------------|
| Name             | BROADCAST_INDEX_REBUILD_PROTOCOL |
| Summary          | broadcast index rebuild protocol |
| Data type        | BOOLEAN                          |
| Applicable phase | NO MOUNT or above                |
| Updatable        | TRUE                             |
| ALTER SESSION    | TRUE                             |
| ALTER SYSTEM     | IMMEDIATE                        |
| MIN              | 0                                |
| MAX              | 1                                |
| Default value    | NO                               |

### Description

It sets whether to simultaneously rebuild the indexes on multiple members when rebuilding the index in a cluster environment.

## 10.10 BROADCAST\_REBALANCE\_PROTOCOL

### Basic Information

| Item             | Description                  |
|------------------|------------------------------|
| Name             | BROADCAST_REBALANCE_PROTOCOL |
| Summary          | broadcast rebalance protocol |
| Data type        | BOOLEAN                      |
| Applicable phase | NO MOUNT or above            |
| Updatable        | TRUE                         |
| ALTER SESSION    | TRUE                         |
| ALTER SYSTEM     | IMMEDIATE                    |
| MIN              | 0                            |
| MAX              | 1                            |
| Default value    | NO                           |

### Description

It sets whether to simultaneously process protocol which can be processed on multiple members at the same time when performing table rebalancing in a cluster environment.

## 10.11 BUFFER\_CACHE\_SIZE

### Basic Information

| Item             | Description                |
|------------------|----------------------------|
| Name             | BUFFER_CACHE_SIZE          |
| Summary          | buffer cache size ( byte ) |
| Data type        | BIGINT                     |
| Applicable phase | NONE                       |
| Updatable        | FALSE                      |
| ALTER SESSION    | FALSE                      |
| ALTER SYSTEM     | FALSE                      |
| MIN              | 1 MB                       |
| MAX              | 1 TB                       |
| Default value    | 64 MB                      |

### Description

It sets the size of the buffer which caches the page in the disk tablespace.



## 10.12 BUFFER\_CHECKPOINT\_LIST\_COUNT

### Basic Information

| Item             | Description                       |
|------------------|-----------------------------------|
| Name             | BUFFER_CHECKPOINT_LIST_COUNT      |
| Summary          | number of buffer checkpoint lists |
| Data type        | BIGINT                            |
| Applicable phase | NONE                              |
| Updatable        | FALSE                             |
| ALTER SESSION    | FALSE                             |
| ALTER SYSTEM     | FALSE                             |
| MIN              | 1                                 |
| MAX              | 36                                |
| Default value    | 1                                 |

### Description

It is linked to the checklist when pages of disk tablespace cached to the buffer are updated. Each checkpoint list flushes updated pages linked to the checkpoint list by its own flush thread to the disk, and BUFFER\_CHECKPOINT\_LIST\_COUNT sets the number of checkpoint lists and the number of flush threads.

## 10.13 BUFFER\_FLUSH\_THREADS

### Basic Information

| Item             | Description                    |
|------------------|--------------------------------|
| Name             | BUFFER_FLUSH_THREADS           |
| Summary          | number of buffer flush threads |
| Data type        | BIGINT                         |
| Applicable phase | NONE                           |
| Updatable        | FALSE                          |
| ALTER SESSION    | FALSE                          |
| ALTER SYSTEM     | FALSE                          |
| MIN              | 1                              |
| MAX              | 36                             |
| Default value    | 1                              |

### Description

It is linked to the flush list then requests flush to the buffer flusher, to reuse bch which cached the updated pages in the buffer lru list. In this case, BUFFER\_FLUSH\_THREADS sets the number of buffer flushers and flush lists to be used in the database.

## 10.14 BUFFER\_FLUSHING\_INTERVAL

### Basic Information

| Item             | Description                         |
|------------------|-------------------------------------|
| Name             | BUFFER_FLUSHING_INTERVAL            |
| Summary          | buffer flushing interval time (sec) |
| Data type        | BIGINT                              |
| Applicable phase | NO MOUNT or above                   |
| Updatable        | TRUE                                |
| ALTER SESSION    | FALSE                               |
| ALTER SYSTEM     | IMMEDIATE                           |
| MIN              | 1                                   |
| MAX              | 86400 (1 day)                       |
| Default value    | 3                                   |

### Description

It sets the idle time (sec) when the job to be processed by the buffer flusher flushing updated disk tablespaces pages to the disk does not exist.

## 10.15 BUFFER\_FREE\_LIST\_COUNT

### Basic Information

| Item             | Description                 |
|------------------|-----------------------------|
| Name             | BUFFER_FREE_LIST_COUNT      |
| Summary          | number of buffer free lists |
| Data type        | BIGINT                      |
| Applicable phase | NONE                        |
| Updatable        | FALSE                       |
| ALTER SESSION    | FALSE                       |
| ALTER SYSTEM     | FALSE                       |
| MIN              | 1                           |
| MAX              | 64                          |
| Default value    | 16                          |

### Description

It sets the number of buffer free lists connecting bch which are instantly available to use in the buffer cache.

## 10.16 BUFFER\_HASH\_BUCKETS

### Basic Information

| Item             | Description                   |
|------------------|-------------------------------|
| Name             | BUFFER_HASH_BUCKETS           |
| Summary          | number of buffer hash buckets |
| Data type        | BIGINT                        |
| Applicable phase | NONE                          |
| Updatable        | FALSE                         |
| ALTER SESSION    | FALSE                         |
| ALTER SYSTEM     | FALSE                         |
| MIN              | 0                             |
| MAX              | 1073741824                    |
| Default value    | 0                             |

### Description

It sets the number of hash buckets for the disk tablespace pages cached in the buffer. It can be set from 0 to 1073741824, and 0 is set by calculating hash buckets as many as pages which can be cached to the buffer which is set according to BUFFER\_CACHE\_SIZE. If the buffer size is smaller than the specified value, then it adjusts the number of hash buckets to the buffer size.

## 10.17 BUFFER\_HOT\_REGION\_CRITERIA

### Basic Information

| Item             | Description                                                |
|------------------|------------------------------------------------------------|
| Name             | BUFFER_HOT_REGION_CRITERIA                                 |
| Summary          | threshold touch count of hot region in the buffer lru list |
| Data type        | BIGINT                                                     |
| Applicable phase | NO MOUNT or above                                          |
| Updatable        | TRUE                                                       |
| ALTER SESSION    | FALSE                                                      |
| ALTER SYSTEM     | IMMEDIATE                                                  |
| MIN              | 2                                                          |
| MAX              | 100                                                        |
| Default value    | 2                                                          |

### Description

It sets touch count to transfer pages existing in the cold region to the hot region in buffer lru list.

## 10.18 BUFFER\_HOT\_REGION\_PERCENT

### Basic Information

| Item             | Description                                         |
|------------------|-----------------------------------------------------|
| Name             | BUFFER_HOT_REGION_PERCENT                           |
| Summary          | the percentage of hot region in the buffer lru list |
| Data type        | BIGINT                                              |
| Applicable phase | NO MOUNT or above                                   |
| Updatable        | TRUE                                                |
| ALTER SESSION    | FALSE                                               |
| ALTER SYSTEM     | IMMEDIATE                                           |
| MIN              | 0                                                   |
| MAX              | 80                                                  |
| Default value    | 20                                                  |

### Description

It sets the proportion (percentage) of hot region pages to the entire page in the buffer lru list.

## 10.19 BUFFER\_LRU\_LIST\_COUNT

### Basic Information

| Item             | Description                |
|------------------|----------------------------|
| Name             | BUFFER_LRU_LIST_COUNT      |
| Summary          | number of buffer LRU lists |
| Data type        | BIGINT                     |
| Applicable phase | NONE                       |
| Updatable        | FALSE                      |
| ALTER SESSION    | FALSE                      |
| ALTER SYSTEM     | FALSE                      |
| MIN              | 1                          |
| MAX              | 64                         |
| Default value    | 16                         |

### Description

It sets the number of lru lists to select a victim among pages in use by caching when the free buffer for caching disk tablespace pages does not exist.



## 10.20 BUFFER\_MULTIPAGE\_READ\_COUNT

### Basic Information

| Item             | Description                                                          |
|------------------|----------------------------------------------------------------------|
| Name             | BUFFER_MULTIPAGE_READ_COUNT                                          |
| Summary          | maximum number of pages read in one I/O operation during a full scan |
| Data type        | BIGINT                                                               |
| Applicable phase | NO MOUNT or above                                                    |
| Updatable        | TRUE                                                                 |
| ALTER SESSION    | TRUE                                                                 |
| ALTER SYSTEM     | DEFERRED                                                             |
| MIN              | 1                                                                    |
| MAX              | 128                                                                  |
| Default value    | 32                                                                   |

### Description

It sets the maximum number of pages to be used for one time disk IO when full scanning the disk table.

## 10.21 BUFFER\_PREFETCH\_PAGE\_COUNT

### Basic Information

| Item             | Description                                                                  |
|------------------|------------------------------------------------------------------------------|
| Name             | BUFFER_PREFETCH_PAGE_COUNT                                                   |
| Summary          | the maximum number of pages to be prefetched to the buffer per I/O operation |
| Data type        | BIGINT                                                                       |
| Applicable phase | NO MOUNT or above                                                            |
| Updatable        | TRUE                                                                         |
| ALTER SESSION    | TRUE                                                                         |
| ALTER SYSTEM     | IMMEDIATE                                                                    |
| MIN              | 1                                                                            |
| MAX              | 128                                                                          |
| Default value    | 32                                                                           |

### Description

It sets the maximum number of pages nearby to be prefetched per a disk I/O when accessing to the page in the disk tablespace which does not exist in the buffer.

## 10.22 BULK\_IO\_PAGE\_COUNT

### Basic Information

| Item             | Description                      |
|------------------|----------------------------------|
| Name             | BULK_IO_PAGE_COUNT               |
| Summary          | page count for bulk IO operation |
| Data type        | BIGINT                           |
| Applicable phase | NO MOUNT or above                |
| Updatable        | TRUE                             |
| ALTER SESSION    | FALSE                            |
| ALTER SYSTEM     | IMMEDIATE                        |
| MIN              | 128                              |
| MAX              | 131072                           |
| Default value    | 3840                             |

### Description

It is used when IO READ of the data file occurs during server restart, or when IO WRITE occurs during creating a data file.

The heap memory is allocated as big as  $BULK\_IO\_PAGE\_COUNT * 8192$  when server restarts or data file is created. If the session's `PRIVATE_STATIC_AREA_SIZE` is smaller than the heap memory size, an error of insufficient memory may occur. In this case, extend `PRIVATE_STATIC_AREA_SIZE`.

## 10.23 CDISPATCHER\_HOT\_POLICY\_INTERVAL

### Basic Information

| Item             | Description                                                    |
|------------------|----------------------------------------------------------------|
| Name             | CDISPATCHER_HOT_POLICY_INTERVAL                                |
| Summary          | cdispatcher dequeue interval for busy waiting ( micro second ) |
| Data type        | BIGINT                                                         |
| Applicable phase | NO MOUNT or above                                              |
| Updatable        | TRUE                                                           |
| ALTER SESSION    | FALSE                                                          |
| ALTER SYSTEM     | IMMEDIATE                                                      |
| MIN              | 0                                                              |
| MAX              | 86400000000 (1day)                                             |
| Default value    | 0                                                              |

### Description

It is the time of the busy waiting when performing the dequeue in the cdispatcher. It is a micro second unit. If this value is big, it uses more cpu but the user response time (latency) is decreased.

The default value is 0, and the busy waiting is not allowed.

## 10.24 CDISPATCHER\_LOCKLESS\_THREADS

### Basic Information

| Item             | Description                                        |
|------------------|----------------------------------------------------|
| Name             | CDISPATCHER_LOCKLESS_THREADS                       |
| Summary          | cdispatcher lockless sender, receiver thread count |
| Data type        | BIGINT                                             |
| Applicable phase | NONE                                               |
| Updatable        | TRUE                                               |
| ALTER SESSION    | FALSE                                              |
| ALTER SYSTEM     | FALSE                                              |
| MIN              | 1                                                  |
| MAX              | 30                                                 |
| Default value    | 1                                                  |

### Description

It sets the number of cdispatcher threads of lockless data sender and receiver. However, the number of c dispatcher threads of lockable data sender and receiver is set by using **CDISPATCHER\_THREADS**.

## 10.25 CDISPATCHER\_SOCKET\_BUFFER\_SIZE

### Basic Information

| Item             | Description                                      |
|------------------|--------------------------------------------------|
| Name             | CDISPATCHER_SOCKET_BUFFER_SIZE                   |
| Summary          | cdispatcher socket buffer(sender, receiver) size |
| Data type        | BIGINT                                           |
| Applicable phase | NONE                                             |
| Updatable        | TRUE                                             |
| ALTER SESSION    | FALSE                                            |
| ALTER SYSTEM     | FALSE                                            |
| MIN              | 64                                               |
| MAX              | 100 Mega                                         |
| Default value    | 32768                                            |

### Description

It is the socket buffer(sender, receiver) size of cdispatcher.

## 10.26 CDISPATCHER\_SYNC\_THREADS

### Basic Information

| Item             | Description                   |
|------------------|-------------------------------|
| Name             | CDISPATCHER_SYNC_THREADS      |
| Summary          | cdispatcher sync thread count |
| Data type        | BIGINT                        |
| Applicable phase | NONE                          |
| Updatable        | TRUE                          |
| ALTER SESSION    | FALSE                         |
| ALTER SYSTEM     | FALSE                         |
| MIN              | 1                             |
| MAX              | 30                            |
| Default value    | 1                             |

### Description

It is the thread count of cdispatcher sync.

## 10.27 CDISPATCHER\_THREADS

### Basic Information

| Item             | Description                                        |
|------------------|----------------------------------------------------|
| Name             | CDISPATCHER_THREADS                                |
| Summary          | cdispatcher lockable sender, receiver thread count |
| Data type        | BIGINT                                             |
| Applicable phase | NONE                                               |
| Updatable        | TRUE                                               |
| ALTER SESSION    | FALSE                                              |
| ALTER SYSTEM     | FALSE                                              |
| MIN              | 1                                                  |
| MAX              | 30                                                 |
| Default value    | 1                                                  |

### Description

It sets the number of cdispatcher threads of lockable data sender and receiver. However, the number of cdispatcher threads of lockless data sender and receiver is set by using **CDISPATCHER\_LOCKLESS\_THREADS**.



## 10.28 CHANGE\_TRACKING

### Basic Information

| Item             | Description                                   |
|------------------|-----------------------------------------------|
| Name             | CHANGE_TRACKING                               |
| Summary          | enable change tracking for incremental backup |
| Data type        | BOOLEAN                                       |
| Applicable phase | NONE                                          |
| Updatable        | FALSE                                         |
| ALTER SESSION    | FALSE                                         |
| ALTER SYSTEM     | FALSE                                         |
| MIN              | 0                                             |
| MAX              | 1                                             |
| Default value    | NO                                            |

### Description

It sets whether to track the updated pages to perform the incremental backup of disk tablespace.

- NO: disable change tracking
- YES: enable change tracking

*change tracking* can be enabled by using `ALTER DATABASE { ENABLE | DISABLE } CHANGE TRACKING` on mount or above phase only when the database is operated in archive log.

## 10.29 CHANGE\_TRACKING\_EXTENT\_SIZE

### Basic Information

| Item             | Description                                            |
|------------------|--------------------------------------------------------|
| Name             | CHANGE_TRACKING_EXTENT_SIZE                            |
| Summary          | number of pages to track changed of incremental backup |
| Data type        | BIGINT                                                 |
| Applicable phase | NONE                                                   |
| Updatable        | FALSE                                                  |
| ALTER SESSION    | FALSE                                                  |
| ALTER SYSTEM     | FALSE                                                  |
| MIN              | 16                                                     |
| MAX              | 128                                                    |
| Default value    | 32                                                     |

### Description

It sets the number of pages to display with one dirty flag when change tracking. For example, if it is set to 32, then one dirty flag is used per 32 pages, and if it is set to 128, then then one dirty flag is used per 128 pages.

## 10.30 CHANGE\_TRACKING\_FILE

### Basic Information

| Item             | Description                                                       |
|------------------|-------------------------------------------------------------------|
| Name             | CHANGE_TRACKING_FILE                                              |
| Summary          | default change tracking file                                      |
| Data type        | VARCHAR                                                           |
| Applicable phase | NO MOUNT or above                                                 |
| Updatable        | TRUE                                                              |
| ALTER SESSION    | FALSE                                                             |
| ALTER SYSTEM     | DEFERRED                                                          |
| MIN              | N/A                                                               |
| MAX              | N/A                                                               |
| Default value    | <code>\$GOLDILOCKS_DATA/backup/gl_change_tracking_file.ctf</code> |

### Description

It sets the file directory which stores the change tracking, and the file name.

## 10.31 CHAR\_LENGTH\_UNITS

### Basic Information

| Item             | Description       |
|------------------|-------------------|
| Name             | CHAR_LENGTH_UNITS |
| Summary          | char length units |
| Data type        | VARCHAR           |
| Applicable phase | NONE              |
| Updatable        | FALSE             |
| ALTER SESSION    | FALSE             |
| ALTER SYSTEM     | FALSE             |
| MIN              | N/A               |
| MAX              | N/A               |
| Default value    | OCTETS            |

### Description

It is the value of char length units used when defining character string such as CHAR, VARCHAR and omitting char length unit as follows.

```
CREATE TABLE t1
(
  id CHAR( 10 OCTETS ),
  name VARCHAR( 128 CHARACTERS ),
  addr VARCHAR( 128 )
);
```

- id CHAR( 10 OCTETS ) means 10 bytes.
- name VARCHAR( 128 CHARACTERS ) means 128 characters.
- addr VARCHAR( 128 ) means that this value is referenced when char length unit is omitted.

When database is created, the property is set to either OCTETS or CHARACTERS. OCTETS is the number of bytes, and CHARACTERS is the number of characters.



The SQL standard defines CHARACTERS as default value. Other DBMS defines the default value of char length unit as follows.

- Oracle and DB2 define OCTETS as default value.
- MS-SQL, MySQL, PostgreSQL define CHARACTERS as default value.

## 10.32 CHARACTER\_SET

### Basic Information

| Item             | Description   |
|------------------|---------------|
| Name             | CHARACTER_SET |
| Summary          | character set |
| Data type        | VARCHAR       |
| Applicable phase | NONE          |
| Updatable        | FALSE         |
| ALTER SESSION    | FALSE         |
| ALTER SYSTEM     | FALSE         |
| MIN              | N/A           |
| MAX              | N/A           |
| Default value    | UTF8          |

### Description

It is a character set of database, and it is applied when database is created.

The property is set to one of the following values.

| Character set | Description                  |
|---------------|------------------------------|
| SQL_ASCII     | ASCII standards              |
| UTF8          | Unicode, 8-bit               |
| UHC           | Unified Hangul code          |
| GB18030       | Chinese government standards |

## 10.33 CHECK\_DEDICATE\_CONNECTION\_INTERVAL

### Basic Information

| Item             | Description                        |
|------------------|------------------------------------|
| Name             | CHECK_DEDICATE_CONNECTION_INTERVAL |
| Summary          | check dedicate socket              |
| Data type        | BIGINT                             |
| Applicable phase | NO MOUNT or above                  |
| Updatable        | TRUE                               |
| ALTER SESSION    | TRUE                               |
| ALTER SYSTEM     | IMMEDIATE                          |
| MIN              | 0                                  |
| MAX              | 100000                             |
| Default value    | 1000                               |

### Description

It is the interval of checking for when the client forcibly cut the connection in C/S dedicate environment. The dedicate server(gserver) checks the socket, and it terminates it if it was cut. The default value is 1,000 millisecond (1 second).

## 10.34 CLIENT\_MAX\_COUNT

### Basic Information

| Item             | Description           |
|------------------|-----------------------|
| Name             | CLIENT_MAX_COUNT      |
| Summary          | maximum session count |
| Data type        | BIGINT                |
| Applicable phase | NONE                  |
| Updatable        | TRUE                  |
| ALTER SESSION    | FALSE                 |
| ALTER SYSTEM     | FALSE                 |
| MIN              | 12                    |
| MAX              | 65535                 |
| Default value    | 128                   |

### Description

It sets the maximum number of sessions to connect.



## 10.35 CLIENT\_NUMA\_POLICY

### Basic Information

| Item             | Description                                                          |
|------------------|----------------------------------------------------------------------|
| Name             | CLIENT_NUMA_POLICY                                                   |
| Summary          | client numa policy( 0: by modular, 1: by statistics , 2: by manual ) |
| Data type        | BIGINT                                                               |
| Applicable phase | NO MOUNT or above                                                    |
| Updatable        | TRUE                                                                 |
| ALTER SESSION    | TRUE                                                                 |
| ALTER SYSTEM     | DEFERRED                                                             |
| MIN              | 0                                                                    |
| MAX              | 2                                                                    |
| Default value    | 0                                                                    |

### Description

It determines the policy to distribute client processes to NUMA nodes. This property is operated when NUMA property is set to on.

- 0: It determines the NUMA node to be connected by modularizing the session ID.
- 1: It connects to the NUMA node of which is the least connected based on the statistics information.
- 2: C/S client is determined by TCP\_CLIENT\_NUMA\_NODE property, D/A client is determined by DA\_CLIENT\_NUMA\_NODE property.

## 10.36 CLOSE\_PSM\_CHILD\_STMTS

### Basic Information

| Item             | Description                                                |
|------------------|------------------------------------------------------------|
| Name             | CLOSE_PSM_CHILD_STMTS                                      |
| Summary          | close child statements of PSM at the end of each execution |
| Data type        | BOOLEAN                                                    |
| Applicable phase | NO MOUNT or above                                          |
| Updatable        | TRUE                                                       |
| ALTER SESSION    | TRUE                                                       |
| ALTER SYSTEM     | DEFERRED                                                   |
| MIN              | 0                                                          |
| MAX              | 1                                                          |
| Default value    | NO                                                         |

### Description

It closes the child statement of PSM at the end of each execution.

## 10.37 CLUSTER\_ASYNC\_COMMIT

### Basic Information

| Item             | Description                                  |
|------------------|----------------------------------------------|
| Name             | CLUSTER_ASYNC_COMMIT                         |
| Summary          | enable asynchronous commit in cluster system |
| Data type        | BOOLEAN                                      |
| Applicable phase | NO MOUNT or above                            |
| Updatable        | TRUE                                         |
| ALTER SESSION    | TRUE                                         |
| ALTER SYSTEM     | IMMEDIATE                                    |
| MIN              | 0                                            |
| MAX              | 1                                            |
| Default value    | YES                                          |

### Description

It determines whether to internally process the commit protocol on an async mode in cluster system.



If this property is set to on, it asynchronously commits each node, so the temporary inconsistency among nodes may occur. On the other hand, if it is set to off, it synchronizes everytime it commits, so it may reduce the performance. Therefore, it is required to determine the appropriate property depending on the purpose.

## 10.38 CLUSTER\_ASYNC\_REPLICATION

### Basic Information

| Item             | Description                     |
|------------------|---------------------------------|
| Name             | CLUSTER_ASYNC_REPLICATION       |
| Summary          | enable asynchronous replication |
| Data type        | BOOLEAN                         |
| Applicable phase | NO MOUNT or above               |
| Updatable        | TRUE                            |
| ALTER SESSION    | TRUE                            |
| ALTER SYSTEM     | IMMEDIATE                       |
| MIN              | 0                               |
| MAX              | 1                               |
| Default value    | YES                             |

### Description

It determines whether to internally process the replication on an async mode in cluster system.



If this property is set to on, it asynchronously reflects the data on each node, so the response time varies upon on which node is connected during the operation. On the other hand, if it is set to off, it synchronizes everytime the data is updated, so it may reduce the performance. Therefore, it is required to determine the appropriate property depending on the purpose.

## 10.39 CLUSTER\_CM\_BUFFER\_COUNT

### Basic Information

| Item             | Description                            |
|------------------|----------------------------------------|
| Name             | CLUSTER_CM_BUFFER_COUNT                |
| Summary          | communication buffer count for cluster |
| Data type        | BIGINT                                 |
| Applicable phase | NONE                                   |
| Updatable        | TRUE                                   |
| ALTER SESSION    | FALSE                                  |
| ALTER SYSTEM     | FALSE                                  |
| MIN              | 1                                      |
| MAX              | 256                                    |
| Default value    | 4                                      |

### Description

It is the communication buffer count for cluster.

## 10.40 CLUSTER\_CM\_BUFFER\_SIZE

### Basic Information

| Item             | Description                           |
|------------------|---------------------------------------|
| Name             | CLUSTER_CM_BUFFER_SIZE                |
| Summary          | communication buffer size for cluster |
| Data type        | BIGINT                                |
| Applicable phase | NONE                                  |
| Updatable        | TRUE                                  |
| ALTER SESSION    | FALSE                                 |
| ALTER SYSTEM     | FALSE                                 |
| MIN              | 10 Mega                               |
| MAX              | 32 Giga                               |
| Default value    | 10 Mega                               |

### Description

It is the communication buffer size for cluster.

## 10.41 CLUSTER\_CM\_READ\_BUFFER\_SIZE

### Basic Information

| Item             | Description                   |
|------------------|-------------------------------|
| Name             | CLUSTER_CM_READ_BUFFER_SIZE   |
| Summary          | communication read block size |
| Data type        | BIGINT                        |
| Applicable phase | NO MOUNT or above             |
| Updatable        | TRUE                          |
| ALTER SESSION    | FALSE                         |
| ALTER SYSTEM     | IMMEDIATE                     |
| MIN              | 8192                          |
| MAX              | 10485,760                     |
| Default value    | 65536                         |

### Description

It is the communication read block size.

## 10.42 CLUSTER\_COMMIT\_SLAVES

### Basic Information

| Item             | Description             |
|------------------|-------------------------|
| Name             | CLUSTER_COMMIT_SLAVES   |
| Summary          | number of commit slaves |
| Data type        | BIGINT                  |
| Applicable phase | NONE                    |
| Updatable        | TRUE                    |
| ALTER SESSION    | FALSE                   |
| ALTER SYSTEM     | FALSE                   |
| MIN              | 1                       |
| MAX              | 8                       |
| Default value    | 1                       |

### Description

It is the number of commit slaves.



## 10.43 CLUSTER\_COMMIT\_STREAM\_ISOLATION

### Basic Information

| Item             | Description                                           |
|------------------|-------------------------------------------------------|
| Name             | CLUSTER_COMMIT_STREAM_ISOLATION                       |
| Summary          | isolate cluster dispatcher stream for commit protocol |
| Data type        | BOOLEAN                                               |
| Applicable phase | NONE                                                  |
| Updatable        | TRUE                                                  |
| ALTER SESSION    | FALSE                                                 |
| ALTER SYSTEM     | FALSE                                                 |
| MIN              | 0                                                     |
| MAX              | 1                                                     |
| Default value    | 0                                                     |

### Description

It determines whether to internally perform the commit process flow in the cluster system separately from other protocol process. The performance may be improved when separating the commit process according to the system environment.

## 10.44 CLUSTER\_CONNECTION

### Basic Information

| Item             | Description                                      |
|------------------|--------------------------------------------------|
| Name             | CLUSTER_CONNECTION                               |
| Summary          | connection mode for cluster ( socket:0, rdma:1 ) |
| Data type        | BIGINT                                           |
| Applicable phase | NONE                                             |
| Updatable        | TRUE                                             |
| ALTER SESSION    | FALSE                                            |
| ALTER SYSTEM     | FALSE                                            |
| MIN              | 0                                                |
| MAX              | 1                                                |
| Default value    | 0: socket                                        |

### Description

It is the connection mode for cluster. ( socket:0, rdma:1 )

## 10.45 CLUSTER\_CONNECTION\_TIMEOUT\_SEC

### Basic Information

| Item             | Description                    |
|------------------|--------------------------------|
| Name             | CLUSTER_CONNECTION_TIMEOUT_SEC |
| Summary          | connection timeout for cluster |
| Data type        | BIGINT                         |
| Applicable phase | NO MOUNT or above              |
| Updatable        | TRUE                           |
| ALTER SESSION    | FALSE                          |
| ALTER SYSTEM     | IMMEDIATE                      |
| MIN              | 0                              |
| MAX              | 86400                          |
| Default value    | 5                              |

### Description

It is the connection timeout for cluster.

## 10.46 CLUSTER\_DATA\_SYNC\_SERVERS

### Basic Information

| Item             | Description                          |
|------------------|--------------------------------------|
| Name             | CLUSTER_DATA_SYNC_SERVERS            |
| Summary          | count of data synchronization server |
| Data type        | BIGINT                               |
| Applicable phase | NONE                                 |
| Updatable        | TRUE                                 |
| ALTER SESSION    | FALSE                                |
| ALTER SYSTEM     | FALSE                                |
| MIN              | 1                                    |
| MAX              | 128                                  |
| Default value    | 3                                    |

### Description

It is the count of data synchronization server.

## 10.47 CLUSTER\_DEADLOCK\_TIMEOUT

### Basic Information

| Item             | Description                                       |
|------------------|---------------------------------------------------|
| Name             | CLUSTER_DEADLOCK_TIMEOUT                          |
| Summary          | a time limit (sec) for resolving cluster deadlock |
| Data type        | BIGINT                                            |
| Applicable phase | NO MOUNT or above                                 |
| Updatable        | TRUE                                              |
| ALTER SESSION    | FALSE                                             |
| ALTER SYSTEM     | IMMEDIATE                                         |
| MIN              | 1                                                 |
| MAX              | 3600 (1 hour)                                     |
| Default value    | 3600 (1 hour)                                     |

### Description

If the competition to occupy the cluster server becomes keen due to the lack of the lockable cluster server, then the cluster deadlock may occur. When cluster deadlock occurs, it waits for the deadlock to be resolved as long as the time set in this property. However, if it is not resolved, then CLUSTER\_DEADLOCK\_TIMEOUT error occurs.

## 10.48 CLUSTER\_DISPATCHER\_IN\_QUEUE\_SIZE

### Basic Information

| Item             | Description                          |
|------------------|--------------------------------------|
| Name             | CLUSTER_DISPATCHER_IN_QUEUE_SIZE     |
| Summary          | in-queue size for cluster dispatcher |
| Data type        | BIGINT                               |
| Applicable phase | NONE                                 |
| Updatable        | TRUE                                 |
| ALTER SESSION    | FALSE                                |
| ALTER SYSTEM     | FALSE                                |
| MIN              | 1024                                 |
| MAX              | 32768                                |
| Default value    | 1024                                 |

### Description

It is the in-queue size for cluster dispatcher.

# 10.49 CLUSTER\_DISPATCHER\_NUMA\_STREAM\_MAP

## AP

### Basic Information

| Item             | Description                            |
|------------------|----------------------------------------|
| Name             | CLUSTER_DISPATCHER_NUMA_STREAM_MAP     |
| Summary          | numa stream map for cluster dispatcher |
| Data type        | VARCHAR                                |
| Applicable phase | NONE                                   |
| Updatable        | TRUE                                   |
| ALTER SESSION    | FALSE                                  |
| ALTER SYSTEM     | FALSE                                  |
| MIN              | N/A                                    |
| MAX              | N/A                                    |
| Default value    | 'x' : no binding                       |

### Description

It determines a NUMA node to which the cluster dispatcher is to be connected. This property is operated when NUMA property is set to on.



If CLUSTER\_COMMIT\_STREAM\_ISOLATION property is set to on, then the 0 stream is set to NUMA node of a commit stream.

The following is an example of three dispatchers. It connects number 0 stream to number 0 NUMA node, connects number 1 stream to number 1 NUMA node, and number 2 stream to number 2 NUMA node.

```
CLUSTER_DISPATCHER_NUMA_STREAM_MAP = '0:1:2'
```

## 10.50 CLUSTER\_DISPATCHER\_OUT\_QUEUE\_SIZE

### Basic Information

| Item             | Description                           |
|------------------|---------------------------------------|
| Name             | CLUSTER_DISPATCHER_OUT_QUEUE_SIZE     |
| Summary          | out-queue size for cluster dispatcher |
| Data type        | BIGINT                                |
| Applicable phase | NONE                                  |
| Updatable        | TRUE                                  |
| ALTER SESSION    | FALSE                                 |
| ALTER SYSTEM     | FALSE                                 |
| MIN              | 1024                                  |
| MAX              | 32768                                 |
| Default value    | 1024                                  |

### Description

It is the out-queue size for cluster dispatcher.



## 10.51 CLUSTER\_HEARTBEAT\_INTERVAL

### Basic Information

| Item             | Description                                     |
|------------------|-------------------------------------------------|
| Name             | CLUSTER_HEARTBEAT_INTERVAL                      |
| Summary          | interval seconds for health checking of cluster |
| Data type        | BIGINT                                          |
| Applicable phase | NO MOUNT or above                               |
| Updatable        | TRUE                                            |
| ALTER SESSION    | FALSE                                           |
| ALTER SYSTEM     | IMMEDIATE                                       |
| MIN              | 0                                               |
| MAX              | 86400                                           |
| Default value    | 3                                               |

### Description

It is the interval seconds for health checking of cluster. 0 means that it is disabled.

## 10.52 CLUSTER\_HEARTBEAT\_RETRY\_COUNT

### Basic Information

| Item             | Description                                |
|------------------|--------------------------------------------|
| Name             | CLUSTER_HEARTBEAT_RETRY_COUNT              |
| Summary          | retry count for health checking of cluster |
| Data type        | BIGINT                                     |
| Applicable phase | NO MOUNT or above                          |
| Updatable        | TRUE                                       |
| ALTER SESSION    | FALSE                                      |
| ALTER SYSTEM     | IMMEDIATE                                  |
| MIN              | 1                                          |
| MAX              | 65536                                      |
| Default value    | 5                                          |

### Description

It is the retry count for health checking of cluster.

## 10.53 CLUSTER\_IGNORE\_INACTIVE\_MEMBER

### Basic Information

| Item             | Description                         |
|------------------|-------------------------------------|
| Name             | CLUSTER_IGNORE_INACTIVE_MEMBER      |
| Summary          | ignore in-active member for cluster |
| Data type        | BOOLEAN                             |
| Applicable phase | NO MOUNT or above                   |
| Updatable        | TRUE                                |
| ALTER SESSION    | TRUE                                |
| ALTER SYSTEM     | FALSE                               |
| MIN              | 0                                   |
| MAX              | 1                                   |
| Default value    | NO                                  |

### Description

It ignores in-active member for cluster.

## 10.54 CLUSTER\_MAX\_PACKET\_SIZE

### Basic Information

| Item             | Description                             |
|------------------|-----------------------------------------|
| Name             | CLUSTER_MAX_PACKET_SIZE                 |
| Summary          | maximum packet size for cluster session |
| Data type        | BIGINT                                  |
| Applicable phase | NO MOUNT or above                       |
| Updatable        | TRUE                                    |
| ALTER SESSION    | FALSE                                   |
| ALTER SYSTEM     | IMMEDIATE                               |
| MIN              | 10 Mega                                 |
| MAX              | 32 Giga                                 |
| Default value    | 100 Mega                                |

### Description

It sets the maximum packet size of which the remote protocol can transfer at a time. If the column size to be remotely transferred exceeds the property size, then the property size should be set bigger than the column size.

## 10.55 CLUSTER\_MAX\_PAYLOAD\_SIZE

### Basic Information

| Item             | Description                                            |
|------------------|--------------------------------------------------------|
| Name             | CLUSTER_MAX_PAYLOAD_SIZE                               |
| Summary          | maximum packet payload size for cluster session (byte) |
| Data type        | BIGINT                                                 |
| Applicable phase | NO MOUNT or above                                      |
| Updatable        | TRUE                                                   |
| ALTER SESSION    | TRUE                                                   |
| ALTER SYSTEM     | IMMEDIATE                                              |
| MIN              | 524288                                                 |
| MAX              | 33554432                                               |
| Default value    | 524288                                                 |

### Description

The cluster packet which is remotely transferred may be delivered in pieces, and this property sets the maximum size of data to be stored in a piece.

## 10.56 CLUSTER\_PACKET\_ALLOCATION\_TIMEOUT

### Basic Information

| Item             | Description                                                                   |
|------------------|-------------------------------------------------------------------------------|
| Name             | CLUSTER_PACKET_ALLOCATION_TIMEOUT                                             |
| Summary          | a time limit (sec) for how long statemets will wait to allocate packet memory |
| Data type        | BIGINT                                                                        |
| Applicable phase | NO MOUNT or above                                                             |
| Updatable        | TRUE                                                                          |
| ALTER SESSION    | FALSE                                                                         |
| ALTER SYSTEM     | IMMEDIATE                                                                     |
| MIN              | 1                                                                             |
| MAX              | 100000000                                                                     |
| Default value    | 3                                                                             |

### Description

It sets the maximum time (second) of waiting when allocating memory required for cluster packet configuration.

# 10.57 CLUSTER\_PROTOCOL\_FAILOVER\_POLICY\_TIMEOUT

## Basic Information

| Item             | Description                                                                      |
|------------------|----------------------------------------------------------------------------------|
| Name             | CLUSTER_PROTOCOL_FAILOVER_POLICY_TIMEOUT                                         |
| Summary          | a time limit of failover policy to wait for a response from the cluster protocol |
| Data type        | BIGINT                                                                           |
| Applicable phase | NO_MOUNT or above                                                                |
| Updatable        | TRUE                                                                             |
| ALTER SESSION    | TRUE                                                                             |
| ALTER SYSTEM     | IMMEDIATE                                                                        |
| MIN              | 0                                                                                |
| MAX              | 100000000                                                                        |
| Default value    | 0                                                                                |

## Description

It is the maximum time of when waiting for the response after transferring the protocol in cluster. If it does not respond within the specified time, then GOLDILOCKS, depending on the protocol, may terminate the protocol or make the remote cluster member which does not respond to be failover. Specify the time limit by using `CLUSTER_PROTOCOL_FAILOVER_POLICY_TIMEOUT` property to use the failover policy. However, specify the time limit by using `CLUSTER_PROTOCOL_SESSION_FATAL_POLICY_TIMEOUT` property to use the policy terminating the session.

## 10.58 CLUSTER\_PROTOCOL\_SESSION\_FATAL\_POLICY\_TIMEOUT

### Basic Information

| Item             | Description                                                                           |
|------------------|---------------------------------------------------------------------------------------|
| Name             | CLUSTER_PROTOCOL_SESSION_FATAL_POLICY_TIMEOUT                                         |
| Summary          | a time limit of session fatal policy to wait for a response from the cluster protocol |
| Data type        | BIGINT                                                                                |
| Applicable phase | NO_MOUNT or above                                                                     |
| Updatable        | TRUE                                                                                  |
| ALTER SESSION    | TRUE                                                                                  |
| ALTER SYSTEM     | IMMEDIATE                                                                             |
| MIN              | 0                                                                                     |
| MAX              | 100000000                                                                             |
| Default value    | 0                                                                                     |

### Description

It is the maximum time of when waiting for the response after transferring the protocol in cluster. If it does not respond within the specified time, then GOLDILOCKS, depending on the protocol, may terminate the protocol or make the remote cluster member which does not respond to be failover. Specify the time limit by using `CLUSTER_PROTOCOL_SESSION_FATAL_POLICY_TIMEOUT` property to use the policy terminating the session. However, specify the time limit by using `CLUSTER_PROTOCOL_FAILOVER_POLICY_TIMEOUT` property to use the failover policy.



## 10.59 CLUSTER\_SERVER\_RESPONSE\_QUEUE\_SIZE

### Basic Information

| Item             | Description                            |
|------------------|----------------------------------------|
| Name             | CLUSTER_SERVER_RESPONSE_QUEUE_SIZE     |
| Summary          | response queue size for cluster server |
| Data type        | BIGINT                                 |
| Applicable phase | NONE                                   |
| Updatable        | TRUE                                   |
| ALTER SESSION    | FALSE                                  |
| ALTER SYSTEM     | FALSE                                  |
| MIN              | 30                                     |
| MAX              | 32768                                  |
| Default value    | 30                                     |

### Description

It sets the maximum queue size to get response from the remote server.

## 10.60 CLUSTER\_SESSION\_HASH\_BUCKETS

### Basic Information

| Item             | Description                                 |
|------------------|---------------------------------------------|
| Name             | CLUSTER_SESSION_HASH_BUCKETS                |
| Summary          | Number of hash buckets for cluster sessions |
| Data type        | BIGINT                                      |
| Applicable phase | NONE                                        |
| Updatable        | TRUE                                        |
| ALTER SESSION    | FALSE                                       |
| ALTER SYSTEM     | FALSE                                       |
| MIN              | 127                                         |
| MAX              | 1073741824                                  |
| Default value    | 127                                         |

### Description

It sets the number of hash buckets to control the cluster session.

# 10.61 CLUSTER\_SPLIT\_BRAIN\_RESOLUTION\_POLICY

## Basic Information

| Item             | Description                                      |
|------------------|--------------------------------------------------|
| Name             | CLUSTER_SPLIT_BRAIN_RESOLUTION_POLICY            |
| Summary          | split brain resolution policy for cluster system |
| Data type        | BIGINT                                           |
| Applicable phase | NO MOUNT or above                                |
| Updatable        | TRUE                                             |
| ALTER SESSION    | FALSE                                            |
| ALTER SYSTEM     | IMMEDIATE                                        |
| MIN              | 0                                                |
| MAX              | 2                                                |
| Default value    | 0                                                |

## Description

It sets the policy to resolve split-brain situation in the cluster system. If the value is set to 1 or over, it enquires the solution of a locator.



If the query for a locator is timed out, it tries to enquire as many times as CLUSTER\_SPLIT\_BRAIN\_RETRY\_COUNT. If the property value after the retry failure is 1, then it forcibly proceeds the fail over. If it is 2, then it terminates the fatal.

## 10.62 CLUSTER\_SPLIT\_BRAIN\_RETRY\_COUNT

### Basic Information

| Item             | Description                                              |
|------------------|----------------------------------------------------------|
| Name             | CLUSTER_SPLIT_BRAIN_RETRY_COUNT                          |
| Summary          | retry count for split brain resolution policy(1 ~ 65536) |
| Data type        | BIGINT                                                   |
| Applicable phase | NO MOUNT or above                                        |
| Updatable        | TRUE                                                     |
| ALTER SESSION    | FALSE                                                    |
| ALTER SYSTEM     | IMMEDIATE                                                |
| MIN              | 1                                                        |
| MAX              | 65536                                                    |
| Default value    | 1                                                        |

### Description

It is used when CLUSTER\_SPLIT\_BRAIN\_RESOLUTION\_POLICY is set to 1 or over in cluster system. It sets the times of retrying to enquire when the query to a locator does not respond.

## 10.63 COMMITTER\_HOT\_POLICY\_INTERVAL

### Basic Information

| Item             | Description                               |
|------------------|-------------------------------------------|
| Name             | COMMITTER_HOT_POLICY_INTERVAL             |
| Summary          | committer deque interval for busy waiting |
| Data type        | BIGINT                                    |
| Applicable phase | NO MOUNT or above                         |
| Updatable        | TRUE                                      |
| ALTER SESSION    | FALSE                                     |
| ALTER SYSTEM     | IMMEDIATE                                 |
| MIN              | 0                                         |
| MAX              | 86400000000 (1 day)                       |
| Default value    | 0 (cold policy)                           |

### Description

It sets the timezone interval of busy waiting when the commit cserver is dequeing to read the commit protocol message. If it is set to 1,000,000 (1 second), and the time is not passed over 1 second from the last deque success to another deque retry, then it sets the timeout in deque to 0 and performs the busy waiting.

## 10.64 CONTROL\_FILE\_0 ~ CONTROL\_FILE\_7

### Basic Information

| Item             | Description                         |
|------------------|-------------------------------------|
| Name             | CONTROL_FILE_0                      |
| Summary          | control file name                   |
| Data type        | VARCHAR                             |
| Applicable phase | NONE                                |
| Updatable        | TRUE                                |
| ALTER SESSION    | FALSE                               |
| ALTER SYSTEM     | FALSE                               |
| MIN              | N/A                                 |
| MAX              | N/A                                 |
| Default value    | \$GOLDILOCKS_DATA/wal/control_0.ctl |

### Description

If a control file is corrupted, database can not be used. Therefore, the control file is multiplexed for stability of database. It specifies the directory and file name of which stores each control file.

## 10.65 CONTROL\_FILE\_COUNT

### Basic Information

| Item             | Description        |
|------------------|--------------------|
| Name             | CONTROL_FILE_COUNT |
| Summary          | control file count |
| Data type        | BIGINT             |
| Applicable phase | NONE               |
| Updatable        | TRUE               |
| ALTER SESSION    | FALSE              |
| ALTER SYSTEM     | FALSE              |
| MIN              | 2                  |
| MAX              | 8                  |
| Default value    | 2                  |

### Description

If a control file is corrupted, database can not be used. The control file is multiplexed for stability of database. CONTROL\_FILE\_COUNT specifies the multiplexing number of control files. A control file is multiplexed at least 2 up to 8.

## 10.66 CONTROL\_FILE\_TEMP\_NAME

### Basic Information

| Item             | Description                          |
|------------------|--------------------------------------|
| Name             | CONTROL_FILE_TEMP_NAME               |
| Summary          | temporary file name for control file |
| Data type        | VARCHAR                              |
| Applicable phase | NO MOUNT or above                    |
| Updatable        | TRUE                                 |
| ALTER SESSION    | FALSE                                |
| ALTER SYSTEM     | DEFERRED                             |
| MIN              | N/A                                  |
| MAX              | N/A                                  |
| Default value    | \$GOLDILOCKS_DATA/backup/control.tmp |

### Description

During database operation, a control file is frequently changed, and its temporary copy can be made if necessary. CONTROL\_FILE\_TEMP\_NAME specifies the directory and its file name to temporarily store the control file.



## 10.67 COORDINATOR\_COMMIT\_WRITE\_MODE

### Basic Information

| Item             | Description                                           |
|------------------|-------------------------------------------------------|
| Name             | COORDINATOR_COMMIT_WRITE_MODE                         |
| Summary          | coordinator commit write mode(0:disable, 1:wait mode) |
| Data type        | BIGINT                                                |
| Applicable phase | NO MOUNT or above                                     |
| Updatable        | TRUE                                                  |
| ALTER SESSION    | FALSE                                                 |
| ALTER SYSTEM     | IMMEDIATE                                             |
| MIN              | 0                                                     |
| MAX              | 1                                                     |
| Default value    | 0                                                     |

### Description

It is a commit write mode applied to a coordinator. If TRANSACTION\_COMMIT\_WRITE\_MODE is *no wait*, and its property is *wait*, then the coordinator node is operated as *wait*, and other nodes are operated as *no wait*.

## 10.68 CSERVERS

### Basic Information

| Item             | Description                          |
|------------------|--------------------------------------|
| Name             | CSERVERS                             |
| Summary          | number of lockable cserver processes |
| Data type        | BIGINT                               |
| Applicable phase | MOUNT or below                       |
| Updatable        | TRUE                                 |
| ALTER SESSION    | FALSE                                |
| ALTER SYSTEM     | IMMEDIATE                            |
| MIN              | 1                                    |
| MAX              | 512                                  |
| Default value    | 10                                   |

### Description

It sets the number of cluster server processes performing the operation which acquires the lock. The number of cluster server processes performing the operation which does not acquire the lock is set by using `LOCKLESS_CServers`.

## 10.69 DA\_CLIENT\_NUMA\_NODE

### Basic Information

| Item             | Description              |
|------------------|--------------------------|
| Name             | DA_CLIENT_NUMA_NODE      |
| Summary          | numa node for DA clients |
| Data type        | BIGINT                   |
| Applicable phase | NONE                     |
| Updatable        | TRUE                     |
| ALTER SESSION    | FALSE                    |
| ALTER SYSTEM     | FALSE                    |
| MIN              | -1                       |
| MAX              | 63                       |
| Default value    | -1                       |

### Description

It sets the NUMA node ID to which the direct access (D/A) session is to be bound. This property is operated when NUMA property is set to ON.

## 10.70 DATA\_STORE\_MODE

### Basic Information

| Item             | Description                  |
|------------------|------------------------------|
| Name             | DATA_STORE_MODE              |
| Summary          | data store mode(cds:1,tds:2) |
| Data type        | BIGINT                       |
| Applicable phase | NONE                         |
| Updatable        | TRUE                         |
| ALTER SESSION    | FALSE                        |
| ALTER SYSTEM     | FALSE                        |
| MIN              | 1                            |
| MAX              | 2                            |
| Default value    | 2                            |

### Description

It sets the storing method of database.

- 1: CDS mode supports the concurrency for multiple users but it does not guarantee the durability. It does not record logs for all update operations such as insert/ delete/ update data, consequentially a failure can not be recovered.
- 2: TDS mode guarantees the concurrency for multiple users and the durability using logs.

## 10.71 DATABASE\_ACCESS\_MODE

### Basic Information

| Item             | Description                                          |
|------------------|------------------------------------------------------|
| Name             | DATABASE_ACCESS_MODE                                 |
| Summary          | database access mode ( 0: read only, 1: read write ) |
| Data type        | BIGINT                                               |
| Applicable phase | NO MOUNT or below                                    |
| Updatable        | TRUE                                                 |
| ALTER SESSION    | FALSE                                                |
| ALTER SYSTEM     | IMMEDIATE                                            |
| MIN              | 0                                                    |
| MAX              | 1                                                    |
| Default value    | 1                                                    |

### Description

When database starts, it sets the access mode.

- 0: It is able to read operation, but unable to insert/ update/ delete operations on database.
- 1: It is able to read/ insert/ update/ delete operations on database.

## 10.72 DATABASE\_INSTANCE\_NAME

### Basic Information

| Item             | Description            |
|------------------|------------------------|
| Name             | DATABASE_INSTANCE_NAME |
| Summary          | database instance name |
| Data type        | VARCHAR                |
| Applicable phase | NONE                   |
| Updatable        | TRUE                   |
| ALTER SESSION    | FALSE                  |
| ALTER SYSTEM     | FALSE                  |
| MIN              | N/A                    |
| MAX              | N/A                    |
| Default value    | GOLDILOCKS             |

### Description

It is the database instance name.

## 10.73 DDL\_AUTOCOMMIT

### Basic Information

| Item             | Description       |
|------------------|-------------------|
| Name             | DDL_AUTOCOMMIT    |
| Summary          | DDL auto commit   |
| Data type        | BOOL              |
| Applicable phase | NO MOUNT or above |
| Updatable        | TRUE              |
| ALTER SESSION    | TRUE              |
| ALTER SYSTEM     | IMMEDIATE         |
| MIN              | 0                 |
| MAX              | 1                 |
| Default value    | NO                |

### Description

It sets whether to autocommit DDL operations which are not autocommitted yet. For example, autocommit is not applied to the operations such as creating/altering a table, so if DDL\_AUTOCOMMIT is 0, a table creation and alteration can be undone by the rollback. On the other hand, if DDL\_AUTOCOMMIT is 1, DDL to which autocommit is not applied is committed immediately.

## 10.74 DDL\_LOCK\_TIMEOUT

### Basic Information

| Item             | Description                                             |
|------------------|---------------------------------------------------------|
| Name             | DDL_LOCK_TIMEOUT                                        |
| Summary          | a time limit (sec) for how long DDL statemets will wait |
| Data type        | BIGINT                                                  |
| Applicable phase | NO MOUNT or above                                       |
| Updatable        | TRUE                                                    |
| ALTER SESSION    | TRUE                                                    |
| ALTER SYSTEM     | IMMEDIATE                                               |
| MIN              | 0                                                       |
| MAX              | 100000000                                               |
| Default value    | 0                                                       |

### Description

It means the lock wait time when DDL operations occur to the same object at the same time. The default value is 0 second, and it does not wait for a lock when the DDL operation occurs.

When operations of altering a table structure simultaneously occur, they wait for the time specified in DDL\_LOCK\_TIMEOUT, without waiting for other transactions termination as follows.

- Transaction A

```
ALTER TABLE t1 ADD COLUMN ( new_column NUMBER );
```

- Transaction B

```
TRUNCATE TABLE t1;
```

If the waiting time exceeds DDL\_LOCK\_TIMEOUT, an error occurs as follows.

```
gSQL> TRUNCATE TABLE t1;
ERR-HYT00(14026): resource busy or timeout expired
```



## 10.75 DEADLOCK\_PRIORITY

### Basic Information

| Item             | Description                          |
|------------------|--------------------------------------|
| Name             | DEADLOCK_PRIORITY                    |
| Summary          | importance to choose deadlock victim |
| Data type        | BIGINT                               |
| Applicable phase | NO MOUNT or above                    |
| Updatable        | TRUE                                 |
| ALTER SESSION    | TRUE                                 |
| ALTER SYSTEM     | FALSE                                |
| MIN              | 0                                    |
| MAX              | 9                                    |
| Default value    | 5                                    |

### Description

When a deadlock occurs while simultaneously processing multiple transactions, a specific transaction with the low weight is selected as a victim among transactions which caused the deadlock, to solve the problem. If a deadlock occurs between a transaction started in sessions which have higher value for this property and a transaction started in sessions which have lower value for this property, then latter is selected as a deadlock victim. Therefore, set this property according to the priority of each transaction.

Start the transaction after setting this property value so that this value is applied as a weight of that transaction. The transaction weight is not altered if this value is changed after the transaction already has been started.

## 10.76 DEFAULT\_GLOBAL\_SECONDARY\_INDEX\_CREATION

### Basic Information

| Item             | Description                                                              |
|------------------|--------------------------------------------------------------------------|
| Name             | DEFAULT_GLOBAL_SECONDARY_INDEX_CREATION                                  |
| Summary          | specifies whether or not create global secondary index at table creation |
| Data type        | BOOLEAN                                                                  |
| Applicable phase | NO MOUNT or above                                                        |
| Updatable        | TRUE                                                                     |
| ALTER SESSION    | TRUE                                                                     |
| ALTER SYSTEM     | FALSE                                                                    |
| MIN              | 0                                                                        |
| MAX              | 1                                                                        |
| Default value    | YES                                                                      |

### Description

It sets whether to create the global secondary index when creating a table in cluster system. A non-deterministic query for the table which did not create the global secondary index fails. The global secondary index can be separately created after creating the table when the property is set to NO.

## 10.77 DEFAULT\_INDEX\_LOGGING



It is not supported after 3.2.

### Basic Information

| Item             | Description                     |
|------------------|---------------------------------|
| Name             | DEFAULT_INDEX_LOGGING           |
| Summary          | default logging flag of indexes |
| Data type        | BOOLEAN                         |
| Applicable phase | NO MOUNT or above               |
| Updatable        | TRUE                            |
| ALTER SESSION    | TRUE                            |
| ALTER SYSTEM     | IMMEDIATE                       |
| MIN              | 0                               |
| MAX              | 1                               |
| Default value    | NO                              |

### Description

If LOGGING property is not explicitly set by a user when an index is created, then it is set to DEFAULT\_INDEX\_LOGGING value. If an index is created in LOGGING tablespace, the LOGGING property should be set.

## 10.78 DEFAULT\_INDEX\_PCTFREE

### Basic Information

| Item             | Description                            |
|------------------|----------------------------------------|
| Name             | DEFAULT_INDEX_PCTFREE                  |
| Summary          | default pctfree value of indexes ( % ) |
| Data type        | BIGINT                                 |
| Applicable phase | NO MOUNT or above                      |
| Updatable        | TRUE                                   |
| ALTER SESSION    | TRUE                                   |
| ALTER SYSTEM     | IMMEDIATE                              |
| MIN              | 0                                      |
| MAX              | 99                                     |
| Default value    | 10                                     |

### Description

If a user does not explicitly specify PCTFREE syntax when creating an index, the PCTFREE is set to DEFAULT\_INDEX\_PCTFREE property value.

## 10.79 DEFAULT\_INITRANS

### Basic Information

| Item             | Description                      |
|------------------|----------------------------------|
| Name             | DEFAULT_INITRANS                 |
| Summary          | default initrans value of tables |
| Data type        | BIGINT                           |
| Applicable phase | NO MOUNT or above                |
| Updatable        | TRUE                             |
| ALTER SESSION    | TRUE                             |
| ALTER SYSTEM     | IMMEDIATE                        |
| MIN              | 1                                |
| MAX              | 32                               |
| Default value    | 4                                |

### Description

If a user does not explicitly set INITRANS syntax when creating a table or an index, then it is set to DEFAULT\_INITRANS property value.

## 10.80 DEFAULT\_MAXTRANS

### Basic Information

| Item             | Description                      |
|------------------|----------------------------------|
| Name             | DEFAULT_MAXTRANS                 |
| Summary          | default maxtrans value of tables |
| Data type        | BIGINT                           |
| Applicable phase | NO MOUNT or above                |
| Updatable        | TRUE                             |
| ALTER SESSION    | TRUE                             |
| ALTER SYSTEM     | IMMEDIATE                        |
| MIN              | 1                                |
| MAX              | 32                               |
| Default value    | 32                               |

### Description

If a user does not explicitly set the MAXTRANS syntax when creating a table or an index, then it is set to DEFAULT\_MAXTRANS property value.

## 10.81 DEFAULT\_PCTFREE

### Basic Information

| Item             | Description                           |
|------------------|---------------------------------------|
| Name             | DEFAULT_PCTFREE                       |
| Summary          | default pctfree value of tables ( % ) |
| Data type        | BIGINT                                |
| Applicable phase | NO MOUNT or above                     |
| Updatable        | TRUE                                  |
| ALTER SESSION    | TRUE                                  |
| ALTER SYSTEM     | IMMEDIATE                             |
| MIN              | 0                                     |
| MAX              | 99                                    |
| Default value    | 10                                    |

### Description

If a user does not explicitly set the PCTFREE property when creating a table, it is set to DEFAULT\_PCTFREE property value.

## 10.82 DEFAULT\_PCTUSED

### Basic Information

| Item             | Description                           |
|------------------|---------------------------------------|
| Name             | DEFAULT_PCTUSED                       |
| Summary          | default pctused value of tables ( % ) |
| Data type        | BIGINT                                |
| Applicable phase | NO MOUNT or above                     |
| Updatable        | TRUE                                  |
| ALTER SESSION    | TRUE                                  |
| ALTER SYSTEM     | IMMEDIATE                             |
| MIN              | 0                                     |
| MAX              | 99                                    |
| Default value    | 60                                    |

### Description

If a user does not explicitly set the PCTUSED property when creating a table, it is set to DEFAULT\_PCTUSED value.



## 10.83 DEFAULT\_REMOVAL\_BACKUP\_FILE

### Basic Information

| Item             | Description                                      |
|------------------|--------------------------------------------------|
| Name             | DEFAULT_REMOVAL_BACKUP_FILE                      |
| Summary          | default removal flag of incremental backup files |
| Data type        | BOOLEAN                                          |
| Applicable phase | NO MOUNT or above                                |
| Updatable        | TRUE                                             |
| ALTER SESSION    | TRUE                                             |
| ALTER SYSTEM     | IMMEDIATE                                        |
| MIN              | 0                                                |
| MAX              | 1                                                |
| Default value    | NO                                               |

### Description

It specifies whether to delete the backup file when deleting the backup list.

## 10.84 DEFAULT\_REMOVAL\_OBSOLETE\_BACKUP\_LIST

### Basic Information

| Item             | Description                                               |
|------------------|-----------------------------------------------------------|
| Name             | DEFAULT_REMOVAL_OBSOLETE_BACKUP_LIST                      |
| Summary          | default removal flag of obsolete incremental backup lists |
| Data type        | BOOLEAN                                                   |
| Applicable phase | NO MOUNT or above                                         |
| Updatable        | TRUE                                                      |
| ALTER SESSION    | TRUE                                                      |
| ALTER SYSTEM     | IMMEDIATE                                                 |
| MIN              | 0                                                         |
| MAX              | 1                                                         |
| Default value    | NO                                                        |

### Description

It specifies whether to delete the previous obsoleted backup list when executing INCREMENTAL BACKUP.

## 10.85 DEFAULT\_SHARDING

### Basic Information

| Item             | Description                                             |
|------------------|---------------------------------------------------------|
| Name             | DEFAULT_SHARDING                                        |
| Summary          | default sharding strategy (0: cloned, 1: hash sharding) |
| Data type        | BOOLEAN                                                 |
| Applicable phase | NO MOUNT or above                                       |
| Updatable        | TRUE                                                    |
| ALTER SESSION    | TRUE                                                    |
| ALTER SYSTEM     | DEFERRED                                                |
| MIN              | 0                                                       |
| MAX              | 1                                                       |
| Default value    | NO                                                      |

### Description

It sets the default sharding strategy to be used if the sharding strategy is not determined when creating a table.

The following is an example of executing CREATE TABLE statement.

```
CREATE TABLE t1
(
  id INTEGER,
  name VARCHAR(128)
);
```

If DEFAULT\_SHARDING value is 0 (cloned), the table is created as a cloned table as follows.

```
CREATE TABLE t1
(
  id INTEGER,
  name VARCHAR(128)
)
CLONED
```

```
AT CLUSTER WIDE
;
```

If DEFAULT\_SHARDING value is 1 (hash sharding), the table is created as a hash-sharded table as follows.

```
CREATE TABLE t1
(
  id INTEGER,
  name VARCHAR(128)
)
SHARDING BY HASH (id)
SHARD COUNT 24
AT CLUSTER WIDE
;
```

If DEFAULT\_SHARDING is 1 (hash sharding) and <table sharding strategy> is not described, then the hash sharding key is determined based on the following order.

1. If PRIMARY KEY constraint is defined, primary key is used as a sharding key.

- The original message

```
CREATE TABLE t1 ( id INTEGER PRIMARY KEY, name VARCHAR(128) );
```

- Translation

```
CREATE TABLE t1 ( id INTEGER PRIMARY KEY, name VARCHAR(128) )
SHARDING BY HASH(id)
SHARD COUNT 24
AT CLUSTER WIDE;
```

2. If UNIQUE constraint is defined, the firstly described UNIQUE constraint is used as the sharding key.

- The original message

```
CREATE TABLE t1 ( id INTEGER, name VARCHAR(128) UNIQUE );
```

- Translation

```
CREATE TABLE t1 ( id INTEGER, name VARCHAR(128) UNIQUE )
SHARDING BY HASH(name)
SHARD COUNT 24
AT CLUSTER WIDE;
```

3. If key constraint is not defined, the first column except for the following excluded data type is used as a sharding key.
  - The excluded data type: LONG VARCHAR, LONG VARBINARY, BOOLEAN

- The original message

```
CREATE TABLE t1 ( is_man BOOLEAN, id INTEGER, name VARCHAR(128) );
```

- Translation

```
CREATE TABLE t1 ( is_man BOOLEAN, id INTEGER, name VARCHAR(128) )  
    SHARDING BY HASH(id)  
    SHARD COUNT 24  
    AT CLUSTER WIDE;
```

## 10.86 DISABLE\_DDL

### Basic Information

| Item             | Description       |
|------------------|-------------------|
| Name             | DISABLE_DDL       |
| Summary          | disable All DDL   |
| Data type        | BOOLEAN           |
| Applicable phase | NO MOUNT or above |
| Updatable        | TRUE              |
| ALTER SESSION    | FALSE             |
| ALTER SYSTEM     | IMMEDIATE         |
| MIN              | 0                 |
| MAX              | 1                 |
| Default value    | NO                |

### Description

It prevents all DDL execution.

The SQL statements which are affected by DISABLE\_DDL are queried as follows.

```
gSQL>
SELECT command
  FROM v$sql_command
 WHERE is_ddl = 'YES'
 ORDER BY 1
;
COMMAND
-----
ALTER AUDIT POLICY
ALTER CLUSTER GROUP .. ADD CLUSTER MEMBER
ALTER CLUSTER GROUP .. OFFLINE CLUSTER MEMBER
ALTER DATABASE ADD LOGFILE GROUP
ALTER DATABASE ADD LOGFILE MEMBER
ALTER DATABASE ARCHIVELOG
ALTER DATABASE CLEAR PASSWORD HISTORY
```

```
ALTER DATABASE DATAFILE AUTOEXTEND ..
ALTER DATABASE DROP INACTIVE CLUSTER MEMBERS
ALTER DATABASE DROP LOGFILE GROUP
ALTER DATABASE DROP LOGFILE MEMBER
ALTER DATABASE NOARCHIVELOG
ALTER DATABASE OFFLINE INACTIVE CLUSTER MEMBERS
ALTER DATABASE RENAME LOGFILE
ALTER DATABASE RESET LOCAL CLUSTER MEMBER
ALTER FUNCTION
ALTER INDEX .. REBUILD
ALTER INDEX .. RENAME
ALTER INDEX .. STORAGE
ALTER INDEX AGING
ALTER PACKAGE
ALTER PROCEDURE
ALTER PROFILE
ALTER SEQUENCE
ALTER SEQUENCE .. SYNCHRONIZE
ALTER SYSTEM SWITCH LOGFILE
ALTER TABLE .. ADD COLUMN
ALTER TABLE .. ADD CONSTRAINT
ALTER TABLE .. ADD GLOBAL SECONDARY INDEX
ALTER TABLE .. ADD SUPPLEMENTAL LOG
ALTER TABLE .. ALTER COLUMN .. AS IDENTITY
ALTER TABLE .. ALTER COLUMN .. DROP DEFAULT
ALTER TABLE .. ALTER COLUMN .. DROP IDENTITY
ALTER TABLE .. ALTER COLUMN .. DROP NOT NULL
ALTER TABLE .. ALTER COLUMN .. SET DATA TYPE
ALTER TABLE .. ALTER COLUMN .. SET DEFAULT
ALTER TABLE .. ALTER COLUMN .. SET NOT NULL
ALTER TABLE .. ALTER CONSTRAINT
ALTER TABLE .. ALTER GLOBAL SECONDARY INDEX
ALTER TABLE .. ALTER GLOBAL SECONDARY INDEX AGING
ALTER TABLE .. DROP CONSTRAINT
ALTER TABLE .. DROP GLOBAL SECONDARY INDEX
ALTER TABLE .. DROP SUPPLEMENTAL LOG
ALTER TABLE .. MERGE SHARDS .. INTO ..
ALTER TABLE .. MOVE SHARD .. TO CLUSTER GROUP ..
ALTER TABLE .. READ ONLY
ALTER TABLE .. READ WRITE
ALTER TABLE .. REBALANCE ..
```

```
ALTER TABLE .. REBUILD GLOBAL SECONDARY INDEX
ALTER TABLE .. RENAME COLUMN
ALTER TABLE .. RENAME CONSTRAINT
ALTER TABLE .. RENAME SHARD .. TO ..
ALTER TABLE .. RENAME TO ..
ALTER TABLE .. SET UNUSED COLUMN
ALTER TABLE .. SPLIT SHARD .. INTO .. AT CLUSTER GROUP ..
ALTER TABLE .. STORAGE
ALTER TABLE .. SYNCHRONIZE IDENTITY COLUMN
ALTER TABLESPACE .. ADD
ALTER TABLESPACE .. DROP
ALTER TABLESPACE .. OFFLINE
ALTER TABLESPACE .. ONLINE
ALTER TABLESPACE .. RENAME TO
ALTER TABLESPACE .. RENAME { DATAFILE | MEMORY }
ALTER USER
ALTER USER .. IDENTIFIED BY
ALTER VIEW
ANALYZE SYSTEM COMPUTE STATISTICS
ANALYZE SYSTEM DELETE STATISTICS
ANALYZE TABLE .. DELETE STATISTICS
ANALYZE TABLE .. [COMPUTE|ESTIMATE] STATISTICS
AUDIT POLICY
COMMENT ON .. IS
CREATE AUDIT POLICY
CREATE CLUSTER GROUP
CREATE FUNCTION
CREATE INDEX
CREATE PACKAGE
CREATE PACKAGE BODY
CREATE PROCEDURE
CREATE PROFILE
CREATE SCHEMA
CREATE SEQUENCE
CREATE SYNONYM
CREATE TABLE
CREATE TABLE ... AS SELECT
CREATE TABLESPACE
CREATE USER
CREATE VIEW
DROP AUDIT POLICY
```



```
DROP CLUSTER GROUP
DROP FUNCTION
DROP INDEX
DROP PACKAGE
DROP PROCEDURE
DROP PROFILE
DROP SCHEMA
DROP SEQUENCE
DROP SYNONYM
DROP TABLE
DROP TABLESPACE
DROP USER
DROP VIEW
FLASHBACK TABLE
GRANT .. ON DATABASE
GRANT .. ON PACKAGE
GRANT .. ON PROCEDURE
GRANT .. ON SCHEMA
GRANT .. ON TABLE
GRANT .. ON TABLESPACE
GRANT USAGE ON ..
NOAUDIT POLICY
PURGE CONSTRAINT
PURGE DBA_RECYCLEBIN
PURGE INDEX
PURGE RECYCLEBIN
PURGE TABLE
PURGE TABLESPACE
REVOKE .. ON DATABASE
REVOKE .. ON PACKAGE
REVOKE .. ON PROCEDURE
REVOKE .. ON SCHEMA
REVOKE .. ON TABLE
REVOKE .. ON TABLESPACE
REVOKE USAGE ON ..
TRUNCATE TABLE
125 rows selected.
```

## 10.87 DISABLE\_DDL\_CDC\_GIVEUP

### Basic Information

| Item             | Description                           |
|------------------|---------------------------------------|
| Name             | DISABLE_DDL_CDC_GIVEUP                |
| Summary          | disable DDL which causing CDC give-up |
| Data type        | BOOLEAN                               |
| Applicable phase | OPEN                                  |
| Updatable        | TRUE                                  |
| ALTER SESSION    | TRUE                                  |
| ALTER SYSTEM     | TRUE                                  |
| MIN              | 0                                     |
| MAX              | 1                                     |
| Default value    | NO                                    |

### Description

It prohibits DDL operation on the table of supplemental log, because it affects CDC's give up.

For more information, refer to **Table 50-1 The occurrence of give up and whether to allow DDL statements according to DDL category.**

## 10.88 DISABLE\_SERIAL\_DDL

### Basic Information

| Item             | Description        |
|------------------|--------------------|
| Name             | DISABLE_SERIAL_DDL |
| Summary          | disable Serial DDL |
| Data type        | BOOLEAN            |
| Applicable phase | NO MOUNT or above  |
| Updatable        | TRUE               |
| ALTER SESSION    | FALSE              |
| ALTER SYSTEM     | IMMEDIATE          |
| MIN              | 0                  |
| MAX              | 1                  |
| Default value    | NO                 |

### Description

DDL is executed for all cluster members after sequentially acquiring locks in cluster environment as described in **Processing DDL in Cluster**.

The DDL which is performed in the serial lock method is called as the serial DDL.

DDL statements which are affected by DISABLE\_SERIAL\_DDL are queried as follows, and most of schema DDLs are affected.

```

gSQL>
SELECT command
       , is_ddl
       , cluster_lock_mode
FROM v$sql_command
WHERE is_ddl = 'YES'
      AND cluster_lock_mode = 'SERIAL'
ORDER BY 1
;
COMMAND                                IS_DDL  CLUSTER_LOCK_MODE
-----
ALTER AUDIT POLICY                      YES     SERIAL

```

|                                                   |     |        |
|---------------------------------------------------|-----|--------|
| ALTER DATABASE CLEAR PASSWORD HISTORY             | YES | SERIAL |
| ALTER DATABASE DATAFILE AUTOEXTEND ..             | YES | SERIAL |
| ALTER FUNCTION                                    | YES | SERIAL |
| ALTER INDEX .. RENAME                             | YES | SERIAL |
| ALTER INDEX .. STORAGE                            | YES | SERIAL |
| ALTER INDEX AGING                                 | YES | SERIAL |
| ALTER PACKAGE                                     | YES | SERIAL |
| ALTER PROCEDURE                                   | YES | SERIAL |
| ALTER PROFILE                                     | YES | SERIAL |
| ALTER SEQUENCE                                    | YES | SERIAL |
| ALTER TABLE .. ADD COLUMN                         | YES | SERIAL |
| ALTER TABLE .. ADD CONSTRAINT                     | YES | SERIAL |
| ALTER TABLE .. ADD GLOBAL SECONDARY INDEX         | YES | SERIAL |
| ALTER TABLE .. ADD SUPPLEMENTAL LOG               | YES | SERIAL |
| ALTER TABLE .. ALTER COLUMN .. AS IDENTITY        | YES | SERIAL |
| ALTER TABLE .. ALTER COLUMN .. DROP DEFAULT       | YES | SERIAL |
| ALTER TABLE .. ALTER COLUMN .. DROP IDENTITY      | YES | SERIAL |
| ALTER TABLE .. ALTER COLUMN .. DROP NOT NULL      | YES | SERIAL |
| ALTER TABLE .. ALTER COLUMN .. SET DATA TYPE      | YES | SERIAL |
| ALTER TABLE .. ALTER COLUMN .. SET DEFAULT        | YES | SERIAL |
| ALTER TABLE .. ALTER COLUMN .. SET NOT NULL       | YES | SERIAL |
| ALTER TABLE .. ALTER CONSTRAINT                   | YES | SERIAL |
| ALTER TABLE .. ALTER GLOBAL SECONDARY INDEX       | YES | SERIAL |
| ALTER TABLE .. ALTER GLOBAL SECONDARY INDEX AGING | YES | SERIAL |
| ALTER TABLE .. DROP CONSTRAINT                    | YES | SERIAL |
| ALTER TABLE .. DROP GLOBAL SECONDARY INDEX        | YES | SERIAL |
| ALTER TABLE .. DROP SUPPLEMENTAL LOG              | YES | SERIAL |
| ALTER TABLE .. READ ONLY                          | YES | SERIAL |
| ALTER TABLE .. READ WRITE                         | YES | SERIAL |
| ALTER TABLE .. RENAME COLUMN                      | YES | SERIAL |
| ALTER TABLE .. RENAME CONSTRAINT                  | YES | SERIAL |
| ALTER TABLE .. RENAME SHARD .. TO ..              | YES | SERIAL |
| ALTER TABLE .. RENAME TO ..                       | YES | SERIAL |
| ALTER TABLE .. SET UNUSED COLUMN                  | YES | SERIAL |
| ALTER TABLE .. STORAGE                            | YES | SERIAL |
| ALTER TABLESPACE .. ADD                           | YES | SERIAL |
| ALTER TABLESPACE .. DROP                          | YES | SERIAL |
| ALTER TABLESPACE .. OFFLINE                       | YES | SERIAL |
| ALTER TABLESPACE .. ONLINE                        | YES | SERIAL |
| ALTER TABLESPACE .. RENAME TO                     | YES | SERIAL |
| ALTER TABLESPACE .. RENAME { DATAFILE   MEMORY }  | YES | SERIAL |

|                                                |     |        |
|------------------------------------------------|-----|--------|
| ALTER USER                                     | YES | SERIAL |
| ALTER USER .. IDENTIFIED BY                    | YES | SERIAL |
| ALTER VIEW                                     | YES | SERIAL |
| ANALYZE SYSTEM COMPUTE STATISTICS              | YES | SERIAL |
| ANALYZE SYSTEM DELETE STATISTICS               | YES | SERIAL |
| ANALYZE TABLE .. DELETE STATISTICS             | YES | SERIAL |
| ANALYZE TABLE .. [COMPUTE ESTIMATE] STATISTICS | YES | SERIAL |
| AUDIT POLICY                                   | YES | SERIAL |
| COMMENT ON .. IS                               | YES | SERIAL |
| CREATE AUDIT POLICY                            | YES | SERIAL |
| CREATE FUNCTION                                | YES | SERIAL |
| CREATE INDEX                                   | YES | SERIAL |
| CREATE PACKAGE                                 | YES | SERIAL |
| CREATE PACKAGE BODY                            | YES | SERIAL |
| CREATE PROCEDURE                               | YES | SERIAL |
| CREATE PROFILE                                 | YES | SERIAL |
| CREATE SCHEMA                                  | YES | SERIAL |
| CREATE SEQUENCE                                | YES | SERIAL |
| CREATE SYNONYM                                 | YES | SERIAL |
| CREATE TABLE                                   | YES | SERIAL |
| CREATE TABLE ... AS SELECT                     | YES | SERIAL |
| CREATE TABLESPACE                              | YES | SERIAL |
| CREATE USER                                    | YES | SERIAL |
| CREATE VIEW                                    | YES | SERIAL |
| DROP AUDIT POLICY                              | YES | SERIAL |
| DROP FUNCTION                                  | YES | SERIAL |
| DROP INDEX                                     | YES | SERIAL |
| DROP PACKAGE                                   | YES | SERIAL |
| DROP PROCEDURE                                 | YES | SERIAL |
| DROP PROFILE                                   | YES | SERIAL |
| DROP SCHEMA                                    | YES | SERIAL |
| DROP SEQUENCE                                  | YES | SERIAL |
| DROP SYNONYM                                   | YES | SERIAL |
| DROP TABLE                                     | YES | SERIAL |
| DROP TABLESPACE                                | YES | SERIAL |
| DROP USER                                      | YES | SERIAL |
| DROP VIEW                                      | YES | SERIAL |
| FLASHBACK TABLE                                | YES | SERIAL |
| GRANT .. ON DATABASE                           | YES | SERIAL |
| GRANT .. ON PACKAGE                            | YES | SERIAL |
| GRANT .. ON PROCEDURE                          | YES | SERIAL |

```

GRANT .. ON SCHEMA                YES    SERIAL
GRANT .. ON TABLE                 YES    SERIAL
GRANT .. ON TABLESPACE            YES    SERIAL
GRANT USAGE ON ..                 YES    SERIAL
NOAUDIT POLICY                     YES    SERIAL
PURGE CONSTRAINT                   YES    SERIAL
PURGE DBA_RECYCLEBIN               YES    SERIAL
PURGE INDEX                        YES    SERIAL
PURGE RECYCLEBIN                   YES    SERIAL
PURGE TABLE                       YES    SERIAL
PURGE TABLESPACE                  YES    SERIAL
REVOKE .. ON DATABASE              YES    SERIAL
REVOKE .. ON PACKAGE               YES    SERIAL
REVOKE .. ON PROCEDURE             YES    SERIAL
REVOKE .. ON SCHEMA                YES    SERIAL
REVOKE .. ON TABLE                YES    SERIAL
REVOKE .. ON TABLESPACE           YES    SERIAL
REVOKE USAGE ON ..                YES    SERIAL
TRUNCATE TABLE                    YES    SERIAL
102 rows selected.

```

DDL statements which are not affected by `DISABLE_SERIAL_DDL` are queried as follows, and most of cluster DDLs are affected.

```

gSQL>
SELECT command
      , is_ddl
      , cluster_lock_mode
FROM v$sql_command
WHERE is_ddl = 'YES'
      AND cluster_lock_mode <> 'SERIAL'
ORDER BY 1
;

```

| COMMAND                                       | IS_DDL | CLUSTER_LOCK_MODE |
|-----------------------------------------------|--------|-------------------|
| ALTER CLUSTER GROUP .. ADD CLUSTER MEMBER     | YES    | MANUAL            |
| ALTER CLUSTER GROUP .. OFFLINE CLUSTER MEMBER | YES    | MANUAL            |
| ALTER DATABASE ADD LOGFILE GROUP              | YES    | NONE              |
| ALTER DATABASE ADD LOGFILE MEMBER             | YES    | NONE              |
| ALTER DATABASE ARCHIVELOG                     | YES    | NONE              |
| ALTER DATABASE DROP INACTIVE CLUSTER MEMBERS  | YES    | MANUAL            |

|                                                           |     |        |
|-----------------------------------------------------------|-----|--------|
| ALTER DATABASE DROP LOGFILE GROUP                         | YES | NONE   |
| ALTER DATABASE DROP LOGFILE MEMBER                        | YES | NONE   |
| ALTER DATABASE NOARCHIVELOG                               | YES | NONE   |
| ALTER DATABASE OFFLINE INACTIVE CLUSTER MEMBERS           | YES | MANUAL |
| ALTER DATABASE RENAME LOGFILE                             | YES | NONE   |
| ALTER DATABASE RESET LOCAL CLUSTER MEMBER                 | YES | NONE   |
| ALTER INDEX .. REBUILD                                    | YES | MANUAL |
| ALTER SEQUENCE .. SYNCHRONIZE                             | YES | MANUAL |
| ALTER SYSTEM SWITCH LOGFILE                               | YES | NONE   |
| ALTER TABLE .. MERGE SHARDS .. INTO ..                    | YES | MANUAL |
| ALTER TABLE .. MOVE SHARD .. TO CLUSTER GROUP ..          | YES | MANUAL |
| ALTER TABLE .. REBALANCE ..                               | YES | MANUAL |
| ALTER TABLE .. REBUILD GLOBAL SECONDARY INDEX             | YES | MANUAL |
| ALTER TABLE .. SPLIT SHARD .. INTO .. AT CLUSTER GROUP .. | YES | MANUAL |
| ALTER TABLE .. SYNCHRONIZE IDENTITY COLUMN                | YES | MANUAL |
| CREATE CLUSTER GROUP                                      | YES | MANUAL |
| DROP CLUSTER GROUP                                        | YES | MANUAL |

23 rows selected.

## 10.89 DISABLE\_UPDATE\_PK\_CDC\_GIVEUP

### Basic Information

| Item             | Description                                         |
|------------------|-----------------------------------------------------|
| Name             | DISABLE_UPDATE_PK_CDC_GIVEUP                        |
| Summary          | disable UPDATE primary key which caused CDC give-up |
| Data type        | BOOLEAN                                             |
| Applicable phase | NO MOUNT or above                                   |
| Updatable        | TRUE                                                |
| ALTER SESSION    | TRUE                                                |
| ALTER SYSTEM     | IMMEDIATE                                           |
| MIN              | 0                                                   |
| MAX              | 1                                                   |
| Default value    | NO                                                  |

### Description

It disables UPDATE primary key which caused CDC give up.



## 10.90 DISALLOWED\_PROTOCOL\_TARGETTYPE

### Basic Information

| Item             | Description                    |
|------------------|--------------------------------|
| Name             | DISALLOWED_PROTOCOL_TARGETTYPE |
| Summary          | disallowed TARGETTYPE protocol |
| Data type        | BOOLEAN                        |
| Applicable phase | NO MOUNT or above              |
| Updatable        | TRUE                           |
| ALTER SESSION    | FALSE                          |
| ALTER SYSTEM     | DEFERRED                       |
| MIN              | 0                              |
| MAX              | 1                              |
| Default value    | NO                             |

### Description

It disallows TARGETTYPE protocol.

# 10.91 DISALLOWED\_PROTOCOL\_TARGETTYPE\_WITH\_ALL

## Basic Information

| Item             | Description                             |
|------------------|-----------------------------------------|
| Name             | DISALLOWED_PROTOCOL_TARGETTYPE_WITH_ALL |
| Summary          | disallowed TARGETTYPE_WITH_ALL protocol |
| Data type        | BOOLEAN                                 |
| Applicable phase | NO MOUNT or above                       |
| Updatable        | TRUE                                    |
| ALTER SESSION    | FALSE                                   |
| ALTER SYSTEM     | DEFERRED                                |
| MIN              | 0                                       |
| MAX              | 1                                       |
| Default value    | NO                                      |

## Description

It disallows TARGETTYPE\_WITH\_ALL protocol.

## 10.92 DISALLOWED\_PROTOCOL\_TARGETTYPE\_WITH\_NAME

### Basic Information

| Item             | Description                              |
|------------------|------------------------------------------|
| Name             | DISALLOWED_PROTOCOL_TARGETTYPE_WITH_NAME |
| Summary          | disallowed TARGETTYPE_WITH_NAME protocol |
| Data type        | BOOLEAN                                  |
| Applicable phase | NO MOUNT or above                        |
| Updatable        | TRUE                                     |
| ALTER SESSION    | FALSE                                    |
| ALTER SYSTEM     | DEFERRED                                 |
| MIN              | 0                                        |
| MAX              | 1                                        |
| Default value    | NO                                       |

### Description

It disallows TARGETTYPE\_WITH\_NAME protocol.

## 10.93 DISPATCHER\_CM\_BUFFER\_SIZE

### Basic Information

| Item             | Description               |
|------------------|---------------------------|
| Name             | DISPATCHER_CM_BUFFER_SIZE |
| Summary          | communication buffer size |
| Data type        | BIGINT                    |
| Applicable phase | NONE                      |
| Updatable        | TRUE                      |
| ALTER SESSION    | FALSE                     |
| ALTER SYSTEM     | FALSE                     |
| MIN              | 10485760                  |
| MAX              | 34359738368               |
| Default value    | 31457280                  |

### Description

It is the size of entire communication buffer used in shared mode. It is allocated to and used in Shared Static Area (SSA).

## 10.94 DISPATCHER\_CM\_UNIT\_SIZE

### Basic Information

| Item             | Description             |
|------------------|-------------------------|
| Name             | DISPATCHER_CM_UNIT_SIZE |
| Summary          | communication unit size |
| Data type        | BIGINT                  |
| Applicable phase | MOUNT or below          |
| Updatable        | TRUE                    |
| ALTER SESSION    | FALSE                   |
| ALTER SYSTEM     | IMMEDIATE               |
| MIN              | 1024                    |
| MAX              | 10485760                |
| Default value    | 1024                    |

### Description

It is the unit size managed by dispatcher in shared mode. If the size is large, the memory is wasted. If it is small, the performance is degraded. It is set to the maximum communication packet size in the shared mode.

## 10.95 DISPATCHER\_CONNECTIONS

### Basic Information

| Item             | Description                                       |
|------------------|---------------------------------------------------|
| Name             | DISPATCHER_CONNECTIONS                            |
| Summary          | maximum number of connections for each dispatcher |
| Data type        | BIGINT                                            |
| Applicable phase | MOUNT or below                                    |
| Updatable        | TRUE                                              |
| ALTER SESSION    | FALSE                                             |
| ALTER SYSTEM     | IMMEDIATE                                         |
| MIN              | 10                                                |
| MAX              | 32768                                             |
| Default value    | 950                                               |

### Description

It is the maximum number of connection (client) which a dispatcher can manage in shared mode.

If the system- supported maximum value is smaller than the set value, it is internally set to the system maximum.

## 10.96 DISPATCHER\_HOT\_POLICY\_INTERVAL

### Basic Information

| Item             | Description                                  |
|------------------|----------------------------------------------|
| Name             | DISPATCHER_HOT_POLICY_INTERVAL               |
| Summary          | dispatcher dequeue interval for busy waiting |
| Data type        | BIGINT                                       |
| Applicable phase | NO MOUNT or above                            |
| Updatable        | TRUE                                         |
| ALTER SESSION    | FALSE                                        |
| ALTER SYSTEM     | IMMEDIATE                                    |
| MIN              | 0                                            |
| MAX              | 86400000000: 1 day                           |
| Default value    | 100000: 0.1 second                           |

### Description

It is the dispatcher dequeue interval for busy waiting. (micro second)

## 10.97 DISPATCHER\_LOAD\_BALANCING

### Basic Information

| Item             | Description                                                                     |
|------------------|---------------------------------------------------------------------------------|
| Name             | DISPATCHER_LOAD_BALANCING                                                       |
| Summary          | load balancing algorithm for shared mode (0: number of clients, 1: round robin) |
| Data type        | BIGINT                                                                          |
| Applicable phase | NO MOUNT or above                                                               |
| Updatable        | TRUE                                                                            |
| ALTER SESSION    | FALSE                                                                           |
| ALTER SYSTEM     | IMMEDIATE                                                                       |
| MIN              | 0                                                                               |
| MAX              | 1                                                                               |
| Default value    | 0                                                                               |

### Description

It is an algorithm allocating a dispatcher when connecting to a client in the shared mode.

- 0: It is allocated to a dispatcher of which the number of currently attached clients are small.
- 1: It is sequentially allocated to a dispatcher.



## 10.98 DISPATCHER\_NUMA\_STREAM\_MAP

### Basic Information

| Item             | Description                    |
|------------------|--------------------------------|
| Name             | DISPATCHER_NUMA_STREAM_MAP     |
| Summary          | numa stream map for dispatcher |
| Data type        | VARCHAR                        |
| Applicable phase | NONE                           |
| Updatable        | TRUE                           |
| ALTER SESSION    | FALSE                          |
| ALTER SYSTEM     | FALSE                          |
| MIN              | N/A                            |
| MAX              | N/A                            |
| Default value    | 'x' : no binding               |

### Description

It determines NUMA node to which dispatchers are to be connected. This property is operated when NUMA property is set to on.

The following is an example of three dispatchers. It connects number 0 stream to number 0 NUMA node, connects number 1 stream to number 1 NUMA node, and number 2 stream to number 2 NUMA node.

**DISPATCHER\_NUMA\_STREAM\_MAP = '0:1:2'**

## 10.99 DISPATCHER\_QUEUE\_SIZE

### Basic Information

| Item             | Description           |
|------------------|-----------------------|
| Name             | DISPATCHER_QUEUE_SIZE |
| Summary          | dispatcher queue size |
| Data type        | BIGINT                |
| Applicable phase | MOUNT or below        |
| Updatable        | TRUE                  |
| ALTER SESSION    | FALSE                 |
| ALTER SYSTEM     | IMMEDIATE             |
| MIN              | 1024                  |
| MAX              | 32768                 |
| Default value    | 1024                  |

### Description

In shared mode, it sets the queue size for the communication between the dispatcher and the shared-server.

# 10.100 DISPATCHER\_REQUEST\_MINI\_QUEUE\_COUNT

## Basic Information

| Item             | Description                           |
|------------------|---------------------------------------|
| Name             | DISPATCHER_REQUEST_MINI_QUEUE_COUNT   |
| Summary          | count of mini queue per request queue |
| Data type        | BIGINT                                |
| Applicable phase | NONE                                  |
| Updatable        | TRUE                                  |
| ALTER SESSION    | FALSE                                 |
| ALTER SYSTEM     | FALSE                                 |
| MIN              | 1                                     |
| MAX              | 16                                    |
| Default value    | 4                                     |

## Description

It is the count of mini queue per request queue.

# 10.101 DISPATCHER\_RESPONSE\_MINI\_QUEUE\_COUNT

## Basic Information

| Item             | Description                            |
|------------------|----------------------------------------|
| Name             | DISPATCHER_RESPONSE_MINI_QUEUE_COUNT   |
| Summary          | count of mini queue per response queue |
| Data type        | BIGINT                                 |
| Applicable phase | NONE                                   |
| Updatable        | TRUE                                   |
| ALTER SESSION    | FALSE                                  |
| ALTER SYSTEM     | FALSE                                  |
| MIN              | 1                                      |
| MAX              | 16                                     |
| Default value    | 4                                      |

## Description

It is the count of mini queue per response queue.

## 10.102 DISPATCHERS

### Basic Information

| Item             | Description                    |
|------------------|--------------------------------|
| Name             | DISPATCHERS                    |
| Summary          | number of dispatcher processes |
| Data type        | BIGINT                         |
| Applicable phase | NO MOUNT or above              |
| Updatable        | TRUE                           |
| ALTER SESSION    | FALSE                          |
| ALTER SYSTEM     | IMMEDIATE                      |
| MIN              | 1                              |
| MAX              | 256                            |
| Default value    | 2                              |

### Description

It sets the number of dispatcher processes when using the shared mode.  
It can not reduce the value by using alter system on open phase.

## 10.103 EXECUTE\_INST\_HASH\_TABLE\_USING\_AVAILABLE\_MEMORY

### Basic Information

| Item             | Description                                                          |
|------------------|----------------------------------------------------------------------|
| Name             | EXECUTE_INST_HASH_TABLE_USING_AVAILABLE_MEMORY                       |
| Summary          | execute instant hash table using available memory even if not enough |
| Data type        | BOOLEAN                                                              |
| Applicable phase | NO_MOUNT or above                                                    |
| Updatable        | TRUE                                                                 |
| ALTER SESSION    | TRUE                                                                 |
| ALTER SYSTEM     | IMMEDIATE                                                            |
| MIN              | 0                                                                    |
| MAX              | 1                                                                    |
| Default value    | YES                                                                  |

### Description

If the memory is not sufficient to expand the hash bucket in the query using an instant hash table, then it determines whether to fail the query or to perform the query without expanding the hash bucket.

## 10.104 FETCH\_FAILOVER

### Basic Information

| Item             | Description           |
|------------------|-----------------------|
| Name             | FETCH_FAILOVER        |
| Summary          | enable fetch failover |
| Data type        | BOOLEAN               |
| Applicable phase | NO MOUNT or above     |
| Updatable        | TRUE                  |
| ALTER SESSION    | TRUE                  |
| ALTER SYSTEM     | FALSE                 |
| MIN              | 0                     |
| MAX              | 1                     |
| Default value    | NO                    |

### Description

It enables the fetch failover.

## 10.105 GLOBAL\_CONNECTION\_ALLOW\_SESSION\_DEPENDENCY

### Basic Information

| Item             | Description                                             |
|------------------|---------------------------------------------------------|
| Name             | GLOBAL_CONNECTION_ALLOW_SESSION_DEPENDENCY              |
| Summary          | allowed session dependent features in global connection |
| Data type        | BOOLEAN                                                 |
| Applicable phase | NO MOUNT or above                                       |
| Updatable        | TRUE                                                    |
| ALTER SESSION    | TRUE                                                    |
| ALTER SYSTEM     | TRUE                                                    |
| MIN              | 0                                                       |
| MAX              | 1                                                       |
| Default value    | NO                                                      |

### Description

It sets whether to support the query execution including the session dependent information in the global connection.



## 10.106 GLOBAL\_JOURNAL\_BUFFER\_SIZE

### Basic Information

| Item             | Description                |
|------------------|----------------------------|
| Name             | GLOBAL_JOURNAL_BUFFER_SIZE |
| Summary          | global journal buffer size |
| Data type        | BIGINT                     |
| Applicable phase | NONE                       |
| Updatable        | TRUE                       |
| ALTER SESSION    | FALSE                      |
| ALTER SYSTEM     | FALSE                      |
| MIN              | 1024                       |
| MAX              | 10 Giga                    |
| Default value    | 1 Mega                     |

### Description

It is the size of global journal buffer.

# 10.107 GLOBAL\_JOURNAL\_BUFFER\_TOTAL\_MAX\_SIZE

## Basic Information

| Item             | Description                          |
|------------------|--------------------------------------|
| Name             | GLOBAL_JOURNAL_BUFFER_TOTAL_MAX_SIZE |
| Summary          | global journal buffer total max size |
| Data type        | BIGINT                               |
| Applicable phase | NONE                                 |
| Updatable        | TRUE                                 |
| ALTER SESSION    | FALSE                                |
| ALTER SYSTEM     | FALSE                                |
| MIN              | 1 Mega                               |
| MAX              | 100 Giga                             |
| Default value    | 64 Mega                              |

## Description

It is the total max size of global journal buffer.

## 10.108 GLOBAL\_PROPERTY\_LOCK\_TIMEOUT

### Basic Information

| Item             | Description                                                                 |
|------------------|-----------------------------------------------------------------------------|
| Name             | GLOBAL_PROPERTY_LOCK_TIMEOUT                                                |
| Summary          | a time limit(second) for how long global property lock statements will wait |
| Data type        | BIGINT                                                                      |
| Applicable phase | NO MOUNT or above                                                           |
| Updatable        | TRUE                                                                        |
| ALTER SESSION    | TRUE                                                                        |
| ALTER SYSTEM     | IMMEDIATE                                                                   |
| MIN              | 0 (infinite)                                                                |
| MAX              | 100000000                                                                   |
| Default value    | 0                                                                           |

### Description

When changing the global property, it performs the lock to control the concurrency. In this case, the waiting time to perform the lock is set.

# 10.109 GLOBAL\_TRANSACTION\_COMMIT\_WRITE\_MODE

## Basic Information

| Item             | Description                                                            |
|------------------|------------------------------------------------------------------------|
| Name             | GLOBAL_TRANSACTION_COMMIT_WRITE_MODE                                   |
| Summary          | global transaction commit write mode (0: no_wait, 1: wait, 2: disable) |
| Data type        | BIGINT                                                                 |
| Applicable phase | NO MOUNT or above                                                      |
| Updatable        | TRUE                                                                   |
| ALTER SESSION    | TRUE                                                                   |
| ALTER SYSTEM     | IMMEDIATE                                                              |
| MIN              | 0                                                                      |
| MAX              | 2                                                                      |
| Default value    | 2                                                                      |

## Description

It is a property to change the commit write mode of the global transaction. TRANSACTION\_COMMIT\_WRITE\_MODE property is applied to all transactions, but GLOBAL\_TRANSACTION\_COMMIT\_WRITE\_MODE property is applied only to a global transaction. If the property is set to 2, then it follows the TRANSACTION\_COMMIT\_WRITE\_MODE.

- 0: It does not wait.
- 1: It waits.
- 2: It follows the value of TRANSACTION\_COMMIT\_WRITE\_MODE.

# 10.110 GLOBAL\_TRANSACTION\_ISOLATION\_SCOPE

## Basic Information

| Item             | Description                                                 |
|------------------|-------------------------------------------------------------|
| Name             | GLOBAL_TRANSACTION_ISOLATION_SCOPE                          |
| Summary          | isolation scope for global transaction(0: system, 1: group) |
| Data type        | BIGINT                                                      |
| Applicable phase | NO MOUNT or above                                           |
| Updatable        | TRUE                                                        |
| ALTER SESSION    | TRUE                                                        |
| ALTER SYSTEM     | IMMEDIATE                                                   |
| MIN              | 0                                                           |
| MAX              | 1                                                           |
| Default value    | 0                                                           |

## Description

It determines whether to process the data with a global transaction or with multiple domain transactions when the transaction changed the data through two cluster groups.

- 0: It processes with a global transaction.
- 1: It processes with multiple domain transactions.



If this property is set to 1, it commits each cluster group with a separate transaction, so it does not guarantee the transaction atomicity.

## 10.111 GLOBAL\_TRANSACTION\_LOG\_DIR

### Basic Information

| Item             | Description                              |
|------------------|------------------------------------------|
| Name             | GLOBAL_TRANSACTION_LOG_DIR               |
| Summary          | default global transaction log directory |
| Data type        | VARCHAR                                  |
| Applicable phase | NO MOUNT or above                        |
| Updatable        | TRUE                                     |
| ALTER SESSION    | FALSE                                    |
| ALTER SYSTEM     | DEFERRED                                 |
| MIN              | N/A                                      |
| MAX              | N/A                                      |
| Default value    | \$(GOLDILOCKS_DATA)/wal                  |

### Description

It is the default directory of global transaction log.

## 10.112 GLOBAL\_TRANSACTION\_LOG\_FILE\_SIZE

### Basic Information

| Item             | Description                      |
|------------------|----------------------------------|
| Name             | GLOBAL_TRANSACTION_LOG_FILE_SIZE |
| Summary          | global transaction log file size |
| Data type        | BIGINT                           |
| Applicable phase | NONE                             |
| Updatable        | TRUE                             |
| ALTER SESSION    | FALSE                            |
| ALTER SYSTEM     | FALSE                            |
| MIN              | 20 Mega                          |
| MAX              | 10 Giga                          |
| Default value    | 100 Mega                         |

### Description

It is the file size of global transaction log.

## 10.113 GMASTER\_NUMA\_NODE

### Basic Information

| Item             | Description                   |
|------------------|-------------------------------|
| Name             | GMASTER_NUMA_NODE             |
| Summary          | numa node for gmaster process |
| Data type        | BIGINT                        |
| Applicable phase | NONE                          |
| Updatable        | TRUE                          |
| ALTER SESSION    | FALSE                         |
| ALTER SYSTEM     | FALSE                         |
| MIN              | -1                            |
| MAX              | 63                            |
| Default value    | -1                            |

### Description

It sets the ID of NUMA node to be used by gmaster daemon. This property is operated when NUMA property is set to on.



## 10.114 GMON\_AUTOSTART

### Basic Information

| Item             | Description                                                         |
|------------------|---------------------------------------------------------------------|
| Name             | GMON_AUTOSTART                                                      |
| Summary          | Indicate whether gmon process automatically starts or not ( 0   1 ) |
| Data type        | BOOLEAN                                                             |
| Applicable phase | MOUNT or below                                                      |
| Updatable        | TRUE                                                                |
| ALTER SESSION    | FALSE                                                               |
| ALTER SYSTEM     | FALSE                                                               |
| MIN              | 0                                                                   |
| MAX              | 1                                                                   |
| Default value    | 1                                                                   |

### Description

It sets whether to start gmon process automatically.

## 10.115 HINT\_ERROR

### Basic Information

| Item             | Description       |
|------------------|-------------------|
| Name             | HINT_ERROR        |
| Summary          | enable hint error |
| Data type        | BOOLEAN           |
| Applicable phase | NO MOUNT or above |
| Updatable        | TRUE              |
| ALTER SESSION    | TRUE              |
| ALTER SYSTEM     | DEFERRED          |
| MIN              | 0                 |
| MAX              | 1                 |
| Default value    | NO                |

### Description

It sets whether to check syntax error and validation error for hint syntax.

# 10.116 IDLE\_TIMEOUT

## Basic Information

| Item             | Description       |
|------------------|-------------------|
| Name             | IDLE_TIMEOUT      |
| Summary          | idle timeout(s)   |
| Data type        | BIGINT            |
| Applicable phase | NO MOUNT or above |
| Updatable        | TRUE              |
| ALTER SESSION    | TRUE              |
| ALTER SYSTEM     | IMMEDIATE         |
| MIN              | 0                 |
| MAX              | 10000000          |
| Default value    | 0                 |

## Description

It sets the maximum IDLE time possible to wait in C/S session. If it exceeds the specified idle time, TIMEOUT error occurs.

- 0: It means infinite waiting, and TIMEOUT error does not occur.

## 10.117 IN\_DOUBT\_DECISION

### Basic Information

| Item             | Description                       |
|------------------|-----------------------------------|
| Name             | IN_DOUBT_DECISION                 |
| Summary          | decision for in-doubt transaction |
| Data type        | BIGINT                            |
| Applicable phase | MOUNT or below                    |
| Updatable        | TRUE                              |
| ALTER SESSION    | FALSE                             |
| ALTER SYSTEM     | IMMEDIATE                         |
| MIN              | 1                                 |
| MAX              | 2                                 |
| Default value    | 2                                 |

### Description

It determines whether to commit or to rollback the in-doubt transaction of distributed transactions.

- 1: Commit
- 2: Rollback

## 10.118 IN\_KEY\_RANGE\_ARRAY\_COUNT

### Basic Information

| Item             | Description                       |
|------------------|-----------------------------------|
| Name             | IN_KEY_RANGE_ARRAY_COUNT          |
| Summary          | array count for in key range scan |
| Data type        | BIGINT                            |
| Applicable phase | NO MOUNT or above                 |
| Updatable        | TRUE                              |
| ALTER SESSION    | TRUE                              |
| ALTER SYSTEM     | DEFERRED                          |
| MIN              | 1                                 |
| MAX              | 65536                             |
| Default value    | 20                                |

### Description

It is the maximum number of values which are targets of *in key range* performing the *in key range scan* based on array.

- IN\_KEY\_RANGE\_ARRAY\_COUNT should be 3 or bigger to perform the *in key range scan* based on array for the statement below.

```
gSQL> SELECT * FROM T1 WHERE C1 IN ( 1, 2, 3 )
```

If the maximum number of in key range target values are bigger than IN\_KEY\_RANGE\_ARRAY\_COUNT value, then in key range in key range scan is performed based on instant table.

# 10.119 INCREMENTAL\_BACKUP\_SCAN\_BUFFER\_SIZE

## Basic Information

| Item             | Description                                                            |
|------------------|------------------------------------------------------------------------|
| Name             | INCREMENTAL_BACKUP_SCAN_BUFFER_SIZE                                    |
| Summary          | number of pages read in one I/O operation during an incremental backup |
| Data type        | BIGINT                                                                 |
| Applicable phase | NO MOUNT or above                                                      |
| Updatable        | TRUE                                                                   |
| ALTER SESSION    | TRUE                                                                   |
| ALTER SYSTEM     | DEFERRED                                                               |
| MIN              | 1                                                                      |
| MAX              | 8192                                                                   |
| Default value    | 32                                                                     |

## Description

It sets the number of pages to read by one time disk IO for performing incremental backup of the disk tablespaces.

## 10.120 INDEX\_BUILD\_PARALLEL\_FACTOR

### Basic Information

| Item             | Description                 |
|------------------|-----------------------------|
| Name             | INDEX_BUILD_PARALLEL_FACTOR |
| Summary          | index build parallel factor |
| Data type        | BIGINT                      |
| Applicable phase | NO MOUNT or above           |
| Updatable        | TRUE                        |
| ALTER SESSION    | TRUE                        |
| ALTER SYSTEM     | IMMEDIATE                   |
| MIN              | 0                           |
| MAX              | 64                          |
| Default value    | 0                           |

### Description

When creating an index, it specifies the number of parallel factor.

- 0: It is specified as the number of the core factor in the system.

## 10.121 INDEX\_LOGGING\_THROTTLING

### Basic Information

| Item             | Description                                                                                   |
|------------------|-----------------------------------------------------------------------------------------------|
| Name             | INDEX_LOGGING_THROTTLING                                                                      |
| Summary          | The limit on the number of dirty blocks in the log buffer during index building or rebuilding |
| Data type        | BIGINT                                                                                        |
| Applicable phase | NO_MOUNT or above                                                                             |
| Updatable        | TRUE                                                                                          |
| ALTER SESSION    | TRUE                                                                                          |
| ALTER SYSTEM     | IMMEDIATE                                                                                     |
| MIN              | 1048576                                                                                       |
| MAX              | 10737418240                                                                                   |
| Default value    | 10737418240                                                                                   |

### Description

This property is used to prevent system overload caused by bulk logging during index creation and rebuild, ensuring that online services are not affected.

If there are more dirty blocks than the specified property value in the log buffer during index logging, it will wait until the dirty blocks are flushed to disk.



## 10.122 INDEX\_REBUILD\_BLOCK\_READ\_COUNT

### Basic Information

| Item             | Description                                    |
|------------------|------------------------------------------------|
| Name             | INDEX_REBUILD_BLOCK_READ_COUNT                 |
| Summary          | value count for a block read for index rebuild |
| Data type        | BIGINT                                         |
| Applicable phase | NO_MOUNT or above                              |
| Updatable        | TRUE                                           |
| ALTER SESSION    | TRUE                                           |
| ALTER SYSTEM     | DEFERRED                                       |
| MIN              | 1                                              |
| MAX              | 65536                                          |
| Default value    | 100                                            |

### Description

When DML is performed while rebuilding the index on ONLINE mode, the journal data is stored. The index is rebuilt based on the data at the time of beginning of the rebuilding, then the updated data during the rebuilding is applied to the index through the journal data. INDEX\_REBUILD\_BLOCK\_READ\_COUNT sets how much journal data to be read and applied to the index during this process.

## 10.123 INDEX\_TREE\_MERGE\_PARALLEL\_FACTOR

### Basic Information

| Item             | Description                           |
|------------------|---------------------------------------|
| Name             | INDEX_TREE_MERGE_PARALLEL_FACTOR      |
| Summary          | parallel factor for merging sub-trees |
| Data type        | BIGINT                                |
| Applicable phase | NO MOUNT or above                     |
| Updatable        | TRUE                                  |
| ALTER SESSION    | TRUE                                  |
| ALTER SYSTEM     | IMMEDIATE                             |
| MIN              | 0                                     |
| MAX              | 64                                    |
| Default value    | 0                                     |

### Description

When creating an index, it specifies the number of parallel factor to merge the sub-tree.

If that value is bigger than INDEX\_BUILD\_PARALLEL\_FACTOR, then INDEX\_BUILD\_PARALLEL\_FACTOR is used.

- 0: It follows INDEX\_BUILD\_PARALLEL\_FACTOR.

## 10.124 INST\_ALLOCATOR\_COUNT

### Basic Information

| Item             | Description                                          |
|------------------|------------------------------------------------------|
| Name             | INST_ALLOCATOR_COUNT                                 |
| Summary          | memory allocator count for instant tables or indexes |
| Data type        | BIGINT                                               |
| Applicable phase | NONE                                                 |
| Updatable        | TRUE                                                 |
| ALTER SESSION    | FALSE                                                |
| ALTER SYSTEM     | FALSE                                                |
| MIN              | 3                                                    |
| MAX              | 128                                                  |
| Default value    | 3                                                    |

### Description

This property increases the parallel property of operation allocating or deleting an instant block.

## 10.125 INST\_HASH\_TABLE\_BUCKET\_MAX\_COUNT

### Basic Information

| Item             | Description                         |
|------------------|-------------------------------------|
| Name             | INST_HASH_TABLE_BUCKET_MAX_COUNT    |
| Summary          | instant hash table bucket max count |
| Data type        | BIGINT                              |
| Applicable phase | NO MOUNT or above                   |
| Updatable        | TRUE                                |
| ALTER SESSION    | TRUE                                |
| ALTER SYSTEM     | DEFERRED                            |
| MIN              | 0                                   |
| MAX              | 4294967295                          |
| Default value    | 0                                   |

### Description

It sets the maximum expected bucket counts of the hash instant table.

# 10.126 INST\_TABLE\_BLOCK\_SIZE

## Basic Information

| Item             | Description                               |
|------------------|-------------------------------------------|
| Name             | INST_TABLE_BLOCK_SIZE                     |
| Summary          | a block size of instant tables or indexes |
| Data type        | BIGINT                                    |
| Applicable phase | NO MOUNT or above                         |
| Updatable        | TRUE                                      |
| ALTER SESSION    | TRUE                                      |
| ALTER SYSTEM     | IMMEDIATE                                 |
| MIN              | 8192                                      |
| MAX              | 1048576                                   |
| Default value    | 16384                                     |

## Description

It determines the size of an instant block. If the anchor area of an instant record is bigger than an instant block, then the following error occurs.

```
gSQL> SELECT DISTINCT * FROM T1, T1, T1, T1, T1, T1, T1, T1, T1, T1;
ERR-HY000(14098): maximum record length(16360) exceeds
```

## 10.127 IPC\_CHANNEL\_COUNT

### Basic Information

| Item             | Description       |
|------------------|-------------------|
| Name             | IPC_CHANNEL_COUNT |
| Summary          | IPC Channel Count |
| Data type        | BIGINT            |
| Applicable phase | NONE              |
| Updatable        | TRUE              |
| ALTER SESSION    | FALSE             |
| ALTER SYSTEM     | FALSE             |
| MIN              | 0                 |
| MAX              | 2048              |
| Default value    | 0                 |

### Description

It sets the number of channels for IPC communication.

# 10.128 JOURNAL\_TEMP\_DIR

## Basic Information

| Item             | Description                    |
|------------------|--------------------------------|
| Name             | JOURNAL_TEMP_DIR               |
| Summary          | journaling temporary directory |
| Data type        | VARCHAR                        |
| Applicable phase | NO MOUNT or above              |
| Updatable        | TRUE                           |
| ALTER SESSION    | FALSE                          |
| ALTER SYSTEM     | DEFERRED                       |
| MIN              | N/A                            |
| MAX              | N/A                            |
| Default value    | \$(GOLDILOCKS_DATA)/journal    |

## Description

It is the temporary directory of journaling.

## 10.129 KEEPALIVE\_IDLE\_TIME

### Basic Information

| Item             | Description                                                    |
|------------------|----------------------------------------------------------------|
| Name             | KEEPALIVE_IDLE_TIME                                            |
| Summary          | tcp keepalive idle time for checking dead client session (sec) |
| Data type        | BIGINT                                                         |
| Applicable phase | NO MOUNT or above                                              |
| Updatable        | TRUE                                                           |
| ALTER SESSION    | FALSE                                                          |
| ALTER SYSTEM     | DEFERRED                                                       |
| MIN              | 1                                                              |
| MAX              | 16383                                                          |
| Default value    | 300                                                            |

### Description

It means the idle duration between the server and client without tcp packet exchange before sending keep alive packet. If there is not tcp packet exchange for seconds (KEEPALIVE\_IDLE\_TIME), keep alive mechanism starts execution to detect the dead connection on the server side.



## 10.130 LOCAL\_CLUSTER\_MEMBER

### Basic Information

| Item             | Description               |
|------------------|---------------------------|
| Name             | LOCAL_CLUSTER_MEMBER      |
| Summary          | local cluster member name |
| Data type        | VARCHAR                   |
| Applicable phase | NONE                      |
| Updatable        | FALSE                     |
| ALTER SESSION    | FALSE                     |
| ALTER SYSTEM     | NONE                      |
| MIN              | N/A                       |
| MAX              | N/A                       |
| Default value    | 'G1N1'                    |

### Description

It is the local cluster member name.

## 10.131 LOCAL\_CLUSTER\_MEMBER\_HOST

### Basic Information

| Item             | Description                       |
|------------------|-----------------------------------|
| Name             | LOCAL_CLUSTER_MEMBER_HOST         |
| Summary          | host name of local cluster member |
| Data type        | VARCHAR                           |
| Applicable phase | NONE                              |
| Updatable        | FALSE                             |
| ALTER SESSION    | FALSE                             |
| ALTER SYSTEM     | NONE                              |
| MIN              | N/A                               |
| MAX              | N/A                               |
| Default value    | '127.0.0.1'                       |

### Description

It is host name of local cluster member.

## 10.132 LOCAL\_CLUSTER\_MEMBER\_PORT

### Basic Information

| Item             | Description                         |
|------------------|-------------------------------------|
| Name             | LOCAL_CLUSTER_MEMBER_PORT           |
| Summary          | listen port of local cluster member |
| Data type        | BIGINT                              |
| Applicable phase | NONE                                |
| Updatable        | FALSE                               |
| ALTER SESSION    | FALSE                               |
| ALTER SYSTEM     | NONE                                |
| MIN              | 1024                                |
| MAX              | 49151                               |
| Default value    | 10101                               |

### Description

It is listen port of local cluster member.

## 10.133 LOCAL\_JOURNAL\_BUFFER\_SIZE

### Basic Information

| Item             | Description               |
|------------------|---------------------------|
| Name             | LOCAL_JOURNAL_BUFFER_SIZE |
| Summary          | local journal buffer size |
| Data type        | BIGINT                    |
| Applicable phase | NONE                      |
| Updatable        | TRUE                      |
| ALTER SESSION    | FALSE                     |
| ALTER SYSTEM     | FALSE                     |
| MIN              | 1024                      |
| MAX              | 10737418240 (10 Giga)     |
| Default value    | 65536                     |

### Description

It is the local journal buffer size.

## 10.134 LOCATION\_FILE

### Basic Information

| Item             | Description                                     |
|------------------|-------------------------------------------------|
| Name             | LOCATION_FILE                                   |
| Summary          | location file name                              |
| Data type        | VARCHAR                                         |
| Applicable phase | NONE                                            |
| Updatable        | TRUE                                            |
| ALTER SESSION    | FALSE                                           |
| ALTER SYSTEM     | FALSE                                           |
| MIN              | N/A                                             |
| MAX              | N/A                                             |
| Default value    | <code>\$GOLDILOCKS_DATA/wal/location.ctl</code> |

### Description

It is the location file name.

## 10.135 LOCATOR\_QUERY\_TIMEOUT

### Basic Information

| Item             | Description                                |
|------------------|--------------------------------------------|
| Name             | LOCATOR_QUERY_TIMEOUT                      |
| Summary          | timeout for waiting locator response (sec) |
| Data type        | BIGINT                                     |
| Applicable phase | NO MOUNT or above                          |
| Updatable        | TRUE                                       |
| ALTER SESSION    | FALSE                                      |
| ALTER SYSTEM     | IMMEDIATE                                  |
| MIN              | 0                                          |
| MAX              | 10000000                                   |
| Default value    | 3                                          |

### Description

It sets the time (second) waiting for the response after the cluster system enquires of a locator about the solution of split-brain situation. This property is used only when CLUSTER\_SPLIT\_BRAIN\_RESOLUTION\_POLICY is set to 1 or more.

## 10.136 LOCK\_HASH\_TABLE\_SIZE

### Basic Information

| Item             | Description                                          |
|------------------|------------------------------------------------------|
| Name             | LOCK_HASH_TABLE_SIZE                                 |
| Summary          | lock manager hash table size (The number of buckets) |
| Data type        | BIGINT                                               |
| Applicable phase | MOUNT or below                                       |
| Updatable        | TRUE                                                 |
| ALTER SESSION    | FALSE                                                |
| ALTER SYSTEM     | IMMEDIATE                                            |
| MIN              | 2                                                    |
| MAX              | 1000000                                              |
| Default value    | 65519                                                |

### Description

It specifies the maximum hash table size managed by a lock manager.

## 10.137 LOCKLESS\_CSERVERS

### Basic Information

| Item             | Description                          |
|------------------|--------------------------------------|
| Name             | LOCKLESS_CSERVERS                    |
| Summary          | number of lockless cserver processes |
| Data type        | BIGINT                               |
| Applicable phase | MOUNT or below                       |
| Updatable        | TRUE                                 |
| ALTER SESSION    | FALSE                                |
| ALTER SYSTEM     | IMMEDIATE                            |
| MIN              | 1                                    |
| MAX              | 2048                                 |
| Default value    | 5                                    |

### Description

It sets the number of cluster server processes performing the operation which does not acquire the lock. The number of cluster server processes performing the operation which acquires the lock is set by using `C SERVERS`.



## 10.138 LOG\_BLOCK\_SIZE

### Basic Information

| Item             | Description           |
|------------------|-----------------------|
| Name             | LOG_BLOCK_SIZE        |
| Summary          | log block size (byte) |
| Data type        | BIGINT                |
| Applicable phase | NONE                  |
| Updatable        | FALSE                 |
| ALTER SESSION    | FALSE                 |
| ALTER SYSTEM     | FALSE                 |
| MIN              | 512                   |
| MAX              | 4096                  |
| Default value    | 512                   |

### Description

It means the minimum size of what log buffer is flushed to the log file of the disk. Its value should be set to one of 512, 1024, 2048, 4096.

## 10.139 LOG\_BUFFER\_SIZE

### Basic Information

| Item             | Description                    |
|------------------|--------------------------------|
| Name             | LOG_BUFFER_SIZE                |
| Summary          | default log buffer size (byte) |
| Data type        | BIGINT                         |
| Applicable phase | NO MOUNT or below              |
| Updatable        | TRUE                           |
| ALTER SESSION    | FALSE                          |
| ALTER SYSTEM     | DEFERRED                       |
| MIN              | 1048576                        |
| MAX              | 10737418240                    |
| Default value    | 10485760                       |

### Description

A log buffer is the shared memory space in which the redo logs generated in database by the DML/DDL operations are stored. LOG\_BUFFER\_SIZE is referenced to set the memory size for the log buffer.

## 10.140 LOG\_DIR

### Basic Information

| Item             | Description           |
|------------------|-----------------------|
| Name             | LOG_DIR               |
| Summary          | default log direcotry |
| Data type        | VARCHAR               |
| Applicable phase | NO MOUNT or above     |
| Updatable        | TRUE                  |
| ALTER SESSION    | FALSE                 |
| ALTER SYSTEM     | DEFERRED              |
| MIN              | N/A                   |
| MAX              | N/A                   |
| Default value    | \$GOLDILOCKS_DATA/wal |

### Description

The log recorded in the log buffer is flushed to the logfile which exists in a non-volatile storage device to ensure the database durability. LOG\_DIR sets the path to the log file.

## 10.141 LOG\_FILE\_SIZE

### Basic Information

| Item             | Description          |
|------------------|----------------------|
| Name             | LOG_FILE_SIZE        |
| Summary          | log file size (byte) |
| Data type        | BIGINT               |
| Applicable phase | NONE                 |
| Updatable        | FALSE                |
| ALTER SESSION    | FALSE                |
| ALTER SYSTEM     | FALSE                |
| MIN              | 20 Mbytes            |
| MAX              | 120 Gbytes           |
| Default value    | 100 Mbytes           |

### Description

It sets the size of the logfile used in database. It is referenced only when creating the database, then log file size can not be updated after then.

## 10.142 LOG\_GROUP\_COUNT

### Basic Information

| Item             | Description                |
|------------------|----------------------------|
| Name             | LOG_GROUP_COUNT            |
| Summary          | initial count of log group |
| Data type        | BIGINT                     |
| Applicable phase | NONE                       |
| Updatable        | FALSE                      |
| ALTER SESSION    | FALSE                      |
| ALTER SYSTEM     | FALSE                      |
| MIN              | 4                          |
| MAX              | 254                        |
| Default value    | 4                          |

### Description

It sets the number of log group used in database. It is referenced only when creating the database, but after that, it does not affect any operations. After creating database, the operation to add or remove a log group is supported by a separate syntax.

## 10.143 LOG\_MIRROR\_MODE

### Basic Information

| Item             | Description                          |
|------------------|--------------------------------------|
| Name             | LOG_MIRROR_MODE                      |
| Summary          | LogMirror Mode (1:Enable, 0:Disable) |
| Data type        | BOOLEAN                              |
| Applicable phase | MOUNT or below                       |
| Updatable        | TRUE                                 |
| ALTER SESSION    | FALSE                                |
| ALTER SYSTEM     | IMMEDIATE                            |
| MIN              | 0                                    |
| MAX              | 1                                    |
| Default value    | NO                                   |

### Description

It is the property to configure the required shared memory when operating LogMirror, the redo log replication tool, at database startup.

It should be enabled to execute the LogMirror.

The size of the shared Memory can be changed using LOG\_MIRROR\_SHARED\_MEMORY\_STATIC\_SIZE.

# 10.144 LOG\_MIRROR\_SHARED\_MEMORY\_STATIC\_SIZE

## Basic Information

| Item             | Description                             |
|------------------|-----------------------------------------|
| Name             | LOG_MIRROR_SHARED_MEMORY_STATIC_SIZE    |
| Summary          | shared memory size for LogMirror (byte) |
| Data type        | BIGINT                                  |
| Applicable phase | MOUNT or below                          |
| Updatable        | TRUE                                    |
| ALTER SESSION    | FALSE                                   |
| ALTER SYSTEM     | IMMEDIATE                               |
| MIN              | 10485760 (10 M)                         |
| MAX              | 1073741824 (1 G)                        |
| Default value    | 104857600 (100 M)                       |

## Description

It sets the size of the shared memory used in LogMirror, the redo log replication tool. It is applied in the state which LOG\_MIRROR\_MODE is enabled.

## 10.145 LOG\_MIRROR\_TIMEOUT

### Basic Information

| Item             | Description                   |
|------------------|-------------------------------|
| Name             | LOG_MIRROR_TIMEOUT            |
| Summary          | logmirror retry timeout (sec) |
| Data type        | BIGINT                        |
| Applicable phase | NO MOUNT or above             |
| Updatable        | TRUE                          |
| ALTER SESSION    | FALSE                         |
| ALTER SYSTEM     | IMMEDIATE                     |
| MIN              | 0                             |
| MAX              | 100000000                     |
| Default value    | 0                             |

### Description

It is the response waiting time of the LogMirror.

If its value is 0, it waits indefinitely. Otherwise, it waits as long as the value set, then TIMEOUT occurs, and it stops LogMirror service. Later, the server is operated normally.

It is applied in the state which LOG\_MIRROR\_MODE is enabled.



## 10.146 LOG\_SYNC\_INTERVAL

### Basic Information

| Item             | Description                      |
|------------------|----------------------------------|
| Name             | LOG_SYNC_INTERVAL                |
| Summary          | interval for synchronize log (s) |
| Data type        | BIGINT                           |
| Applicable phase | NO MOUNT or above                |
| Updatable        | TRUE                             |
| ALTER SESSION    | FALSE                            |
| ALTER SYSTEM     | IMMEDIATE                        |
| MIN              | 1                                |
| MAX              | 10000                            |
| Default value    | 3                                |

### Description

Log flusher of GOLDILOCKS is a system thread which flushes the log buffer contents to disk logfile. When log flusher wakes up in the idle phase, it checks if log to flush exists. Then it flushes the log if any. If the log flusher did not flush within the time set in LOG\_SYNC\_INTERVAL, it synchronizes the log buffer and the log file by performing a flush until the last block of the current log buffer.

## 10.147 LOG\_SYNC\_INTERVAL\_MSEC

### Basic Information

| Item             | Description                               |
|------------------|-------------------------------------------|
| Name             | LOG_SYNC_INTERVAL_MSEC                    |
| Summary          | milli-second interval for synchronize log |
| Data type        | BIGINT                                    |
| Applicable phase | NO MOUNT or above                         |
| Updatable        | TRUE                                      |
| ALTER SESSION    | FALSE                                     |
| ALTER SYSTEM     | IMMEDIATE                                 |
| MIN              | 0                                         |
| MAX              | 10000000                                  |
| Default value    | 0                                         |

### Description

It is the millisecond interval for synchronize log.

## 10.148 MAX\_GROUP\_COUNT

### Basic Information

| Item             | Description         |
|------------------|---------------------|
| Name             | MAX_GROUP_COUNT     |
| Summary          | maximum group count |
| Data type        | BIGINT              |
| Applicable phase | NONE                |
| Updatable        | TRUE                |
| ALTER SESSION    | FALSE               |
| ALTER SYSTEM     | FALSE               |
| MIN              | 0                   |
| MAX              | 8192                |
| Default value    | 32                  |

### Description

It is the maximum group count in the cluster system.

## 10.149 MAX\_JOURNAL\_FILE\_SIZE

### Basic Information

| Item             | Description                 |
|------------------|-----------------------------|
| Name             | MAX_JOURNAL_FILE_SIZE       |
| Summary          | maximum journal file size   |
| Data type        | BIGINT                      |
| Applicable phase | MOUNT or above              |
| Updatable        | TRUE                        |
| ALTER SESSION    | FALSE                       |
| ALTER SYSTEM     | IMMEDIATE                   |
| MIN              | 0                           |
| MAX              | 1099511627776 (1 Terabytes) |
| Default value    | 0 (no limit)                |

### Description

It sets the maximum size (quota) of the global journaling file which internally stores journaling data when a journaling occurs in cluster system.

## 10.150 MAX\_NODE\_COUNT

### Basic Information

| Item             | Description        |
|------------------|--------------------|
| Name             | MAX_NODE_COUNT     |
| Summary          | maximum node count |
| Data type        | BIGINT             |
| Applicable phase | NONE               |
| Updatable        | FALSE              |
| ALTER SESSION    | FALSE              |
| ALTER SYSTEM     | NONE               |
| MIN              | 1                  |
| MAX              | 8192               |
| Default value    | 64                 |

### Description

It is the maximum node (instance) count which can join the cluster system.

## 10.151 MAXIMUM\_CONCURRENT\_ACTIVITIES

### Basic Information

| Item             | Description                                                                      |
|------------------|----------------------------------------------------------------------------------|
| Name             | MAXIMUM_CONCURRENT_ACTIVITIES                                                    |
| Summary          | maximum number of active statements that the driver can support for a connection |
| Data type        | BIGINT                                                                           |
| Applicable phase | NO MOUNT or above                                                                |
| Updatable        | TRUE                                                                             |
| ALTER SESSION    | FALSE                                                                            |
| ALTER SYSTEM     | DEFERRED                                                                         |
| MIN              | 1                                                                                |
| MAX              | 65535                                                                            |
| Default value    | 1024                                                                             |

### Description

It sets the number of statements which can be executed simultaneously.

## 10.152 MAXIMUM\_FILE\_CACHE\_SIZE

### Basic Information

| Item             | Description                        |
|------------------|------------------------------------|
| Name             | MAXIMUM_FILE_CACHE_SIZE            |
| Summary          | the limit of file descriptor cache |
| Data type        | BIGINT                             |
| Applicable phase | NO MOUNT or above                  |
| Updatable        | TRUE                               |
| ALTER SESSION    | FALSE                              |
| ALTER SYSTEM     | IMMEDIATE                          |
| MIN              | 16                                 |
| MAX              | 32768                              |
| Default value    | 128                                |

### Description

It sets the maximum number of file caches which is being used in the session.

## 10.153 MAXIMUM\_FLANGE\_COUNT

### Basic Information

| Item             | Description                          |
|------------------|--------------------------------------|
| Name             | MAXIMUM_FLANGE_COUNT                 |
| Summary          | maximum flange count in a plan clock |
| Data type        | BIGINT                               |
| Applicable phase | NO MOUNT or above                    |
| Updatable        | TRUE                                 |
| ALTER SESSION    | FALSE                                |
| ALTER SYSTEM     | IMMEDIATE                            |
| MIN              | 128                                  |
| MAX              | 65535                                |
| Default value    | 1024                                 |

### Description

It is the maximum number of flanges which can be expanded in plan clock.



# 10.154 MAXIMUM\_FLUSH\_BUFFER\_PAGE\_COUNT

## Basic Information

| Item             | Description                                        |
|------------------|----------------------------------------------------|
| Name             | MAXIMUM_FLUSH_BUFFER_PAGE_COUNT                    |
| Summary          | maximum number of buffer page count to be flushing |
| Data type        | BIGINT                                             |
| Applicable phase | NO MOUNT or above                                  |
| Updatable        | TRUE                                               |
| ALTER SESSION    | FALSE                                              |
| ALTER SYSTEM     | IMMEDIATE                                          |
| MIN              | 1                                                  |
| MAX              | 8192                                               |
| Default value    | 64                                                 |

## Description

It sets the maximum number of pages which can be recorded per disk writing operation. If the pages in the disk tablespace are updated in the buffer, then IO thread records them on the disk. If recording nearby pages together when performing disk writing operation, then it increases the efficiency of the system resource by decreasing the number of disk recording.

## 10.155 MAXIMUM\_FLUSH\_LOG\_BLOCK\_COUNT

### Basic Information

| Item             | Description                                      |
|------------------|--------------------------------------------------|
| Name             | MAXIMUM_FLUSH_LOG_BLOCK_COUNT                    |
| Summary          | maximum number of log block count to be flushing |
| Data type        | BIGINT                                           |
| Applicable phase | NO MOUNT or above                                |
| Updatable        | TRUE                                             |
| ALTER SESSION    | FALSE                                            |
| ALTER SYSTEM     | IMMEDIATE                                        |
| MIN              | 1000                                             |
| MAX              | 2000000                                          |
| Default value    | 100000                                           |

### Description

When flushing the contents of the log buffer to disk log file, it sets the maximum number of log blocks to be flushed with a single writing operation.

## 10.156 MAXIMUM\_FLUSH\_PAGE\_COUNT

### Basic Information

| Item             | Description                                 |
|------------------|---------------------------------------------|
| Name             | MAXIMUM_FLUSH_PAGE_COUNT                    |
| Summary          | maximum number of page count to be flushing |
| Data type        | BIGINT                                      |
| Applicable phase | NO MOUNT or above                           |
| Updatable        | TRUE                                        |
| ALTER SESSION    | FALSE                                       |
| ALTER SYSTEM     | IMMEDIATE                                   |
| MIN              | 1                                           |
| MAX              | 8192                                        |
| Default value    | 1024                                        |

### Description

GOLDILOCKS datafiles are flushed to the disk by the checkpoint and certain DDL statements. For flushing datafiles, it sets the maximum number of data pages to be flushed with a single writing operation.

# 10.157 MAXIMUM\_INDEX\_REBUILD\_JOURNAL\_REPLAY\_COUNT

## Basic Information

| Item             | Description                                            |
|------------------|--------------------------------------------------------|
| Name             | MAXIMUM_INDEX_REBUILD_JOURNAL_REPLAY_COUNT             |
| Summary          | maximum number of replaying journals for rebuild index |
| Data type        | BIGINT                                                 |
| Applicable phase | NO_MOUNT or above                                      |
| Updatable        | TRUE                                                   |
| ALTER SESSION    | TRUE                                                   |
| ALTER SYSTEM     | IMMEDIATE                                              |
| MIN              | 2                                                      |
| MAX              | 1024                                                   |
| Default value    | 2                                                      |

## Description

When rebuilding the index on ONLINE mode, it can be performed together with DML, and DML records the updates on the journal log. The index is rebuilt based on the data at the time of beginning of the rebuilding, then the updated data during the rebuilding is applied to the index through the journal log. The journal logs are initially applied, then journal logs which were accumulated while applying the journal logs are applied. This property sets how many times the journal logs are applied in this way.

## 10.158 MAXIMUM\_JOURNAL\_REPLAY\_COUNT

### Basic Information

| Item             | Description                                              |
|------------------|----------------------------------------------------------|
| Name             | MAXIMUM_JOURNAL_REPLAY_COUNT                             |
| Summary          | maximum number of replaying journals for rebalance table |
| Data type        | BIGINT                                                   |
| Applicable phase | NO_MOUNT or above                                        |
| Updatable        | TRUE                                                     |
| ALTER SESSION    | TRUE                                                     |
| ALTER SYSTEM     | IMMEDIATE                                                |
| MIN              | 2                                                        |
| MAX              | 1024                                                     |
| Default value    | 2                                                        |

### Description

The table rebalancing online can be performed together with DML in the cluster environment, and DML records the updates on the journal log at that moment. The table rebalancing initially applies the journal logs which occurred during synchronizing tables, then applies journal logs which were accumulated while applying the journal logs. This property sets how many times the journal logs are applied in this way.

## 10.159 MAXIMUM\_NAMED\_CURSOR\_COUNT

### Basic Information

| Item             | Description                                                                 |
|------------------|-----------------------------------------------------------------------------|
| Name             | MAXIMUM_NAMED_CURSOR_COUNT                                                  |
| Summary          | maximum number of named cursor that the driver can support for a connection |
| Data type        | BIGINT                                                                      |
| Applicable phase | NO MOUNT or above                                                           |
| Updatable        | TRUE                                                                        |
| ALTER SESSION    | FALSE                                                                       |
| ALTER SYSTEM     | DEFERRED                                                                    |
| MIN              | 1                                                                           |
| MAX              | 100000                                                                      |
| Default value    | 128                                                                         |

### Description

It is the maximum number of named cursor which can be used within a single session.

A named cursor is created in the following cases.

- When a named cursor is declared using functions like `SQLSetCursorName()`, `SQLGetCursorName()`

```
{
  ...
  SQLSetCursorName( stmt,
                   "my_cursor",
                   SQL_NTS );
  ...
}
```

- When the DECLARE cursor syntax is used by a function such as `SQLExecDirect ()`, `SQLPrepare ()`

```
{
  ...
  SQLExecDirect( stmt,
                "DECLARE my_cursor CURSOR FOR SELECT col_name FROM tab_name",
```

```

        SQL_NTS );
    ...
}

```

- When DECLARE cursor FOR UPDATE syntax is used in an embedded SQL

```

{
    ...
    EXEC SQL DECLARE my_cursor CURSOR FOR SELECT col_name FROM tab_name FOR UPDATE;
    ...
    EXEC SQL OPEN my_cursor;
    ...
    EXEC SQL FETCH my_cursor INTO :data;
    EXEC SQL DELETE FROM tab_name WHERE CURRENT OF my_cursor;
    ...
    EXEC SQL CLOSE my_cursor;
}

```



In an embedded SQL, DECLARE CURSOR syntax without FOR UPDATE as follows does not create a named cursor on the session.

```

{
    ...
    EXEC SQL DECLARE my_cursor CURSOR FOR SELECT col_name FROM tab_name;
    ...
}

```

## 10.160 MAXIMUM\_PACKAGE\_INSTANCE\_COUNT

### Basic Information

| Item             | Description                                                                     |
|------------------|---------------------------------------------------------------------------------|
| Name             | MAXIMUM_PACKAGE_INSTANCE_COUNT                                                  |
| Summary          | maximum number of package instance that the driver can support for a connection |
| Data type        | BIGINT                                                                          |
| Applicable phase | NO MOUNT or above                                                               |
| Updatable        | TRUE                                                                            |
| ALTER SESSION    | FALSE                                                                           |
| ALTER SYSTEM     | DEFERRED                                                                        |
| MIN              | 1                                                                               |
| MAX              | 100000                                                                          |
| Default value    | 128                                                                             |

### Description

It is the maximum number of package instances which are available in a single session. A package instance is created when using the stateful package in the session.



## 10.161 MAXIMUM\_SESSION\_CM\_BUFFER\_SIZE

### Basic Information

| Item             | Description                                         |
|------------------|-----------------------------------------------------|
| Name             | MAXIMUM_SESSION_CM_BUFFER_SIZE                      |
| Summary          | maximum communication bytes per shared mode session |
| Data type        | BIGINT                                              |
| Applicable phase | MOUNT or below                                      |
| Updatable        | TRUE                                                |
| ALTER SESSION    | TRUE                                                |
| ALTER SYSTEM     | IMMEDIATE                                           |
| MIN              | 1048576                                             |
| MAX              | 1073741824                                          |
| Default value    | 20971520                                            |

### Description

It sets the maximum buffer size available in a single session which is connected to shared mode. For more information, refer to **DISPATCHER\_CM\_BUFFER\_SIZE**.

## 10.162 MEASURE\_CLUSTER\_LATENCY

### Basic Information

| Item             | Description             |
|------------------|-------------------------|
| Name             | MEASURE_CLUSTER_LATENCY |
| Summary          | measure cluster latency |
| Data type        | BOOL                    |
| Applicable phase | NO MOUNT or above       |
| Updatable        | TRUE                    |
| ALTER SESSION    | TRUE                    |
| ALTER SYSTEM     | IMMEDIATE               |
| MIN              | 0                       |
| MAX              | 1                       |
| Default value    | NO                      |

### Description

It is the measure cluster latency.

## 10.163 MEMORY\_MERGE\_RUN\_COUNT

### Basic Information

| Item             | Description                      |
|------------------|----------------------------------|
| Name             | MEMORY_MERGE_RUN_COUNT           |
| Summary          | merge run count for memory index |
| Data type        | BIGINT                           |
| Applicable phase | NO MOUNT or above                |
| Updatable        | TRUE                             |
| ALTER SESSION    | TRUE                             |
| ALTER SYSTEM     | IMMEDIATE                        |
| MIN              | 2                                |
| MAX              | 64                               |
| Default value    | 32                               |

### Description

Memory B-tree index of bottom-up approach is created by extracting all keys from a table, sorting them in certain block size (MEMORY\_SORT\_RUN\_SIZE) units, merging the sorted blocks, and generating the internal node. MEMORY\_MERGE\_RUN\_COUNT sets the number of the sorted blocks to be merged at a time.

## 10.164 MEMORY\_SORT\_RUN\_SIZE

### Basic Information

| Item             | Description                           |
|------------------|---------------------------------------|
| Name             | MEMORY_SORT_RUN_SIZE                  |
| Summary          | sort run size for memory index (byte) |
| Data type        | BIGINT                                |
| Applicable phase | NO MOUNT or above                     |
| Updatable        | TRUE                                  |
| ALTER SESSION    | TRUE                                  |
| ALTER SYSTEM     | IMMEDIATE                             |
| MIN              | 8192                                  |
| MAX              | 32768                                 |
| Default value    | 8192                                  |

### Description

Memory B-tree index of bottom-up approach is created by extracting all keys from a table, sorting them in a certain block size (MEMORY\_SORT\_RUN\_SIZE) unit, merging the sorted blocks, and generating the internal node. MEMORY\_SORT\_RUN\_SIZE sets the size of a single block to be sorted.

## 10.165 MIN\_SAMPLE\_ROW\_COUNT

### Basic Information

| Item             | Description                                  |
|------------------|----------------------------------------------|
| Name             | MIN_SAMPLE_ROW_COUNT                         |
| Summary          | minimum sampling row count for analyze table |
| Data type        | BIGINT                                       |
| Applicable phase | NO MOUNT or above                            |
| Updatable        | TRUE                                         |
| ALTER SESSION    | TRUE                                         |
| ALTER SYSTEM     | DEFERRED                                     |
| MIN              | 0                                            |
| MAX              | 9223372036854775807 (INT64_MAX)              |
| Default value    | 100000                                       |

### Description

It is the minimum number of sampling rows when executing **ANALYZE TABLE** by using the sampling.

# 10.166 MINIMUM\_UNDO\_PAGE\_COUNT

## Basic Information

| Item             | Description             |
|------------------|-------------------------|
| Name             | MINIMUM_UNDO_PAGE_COUNT |
| Summary          | minimum undo page count |
| Data type        | BIGINT                  |
| Applicable phase | NO MOUNT or above       |
| Updatable        | TRUE                    |
| ALTER SESSION    | FALSE                   |
| ALTER SYSTEM     | IMMEDIATE               |
| MIN              | 16                      |
| MAX              | 1048576                 |
| Default value    | 16                      |

## Description

DML uses the undo page to store the previous image. Undo page is consumed by using a single undo segment per DML. If all allocated pages of undo segments are consumed, the page of another undo segment can be used. MINIMUM UNDO PAGE\_COUNT is the minimum number of undo page to specify the undo segment to import page when undo pages are insufficient. If the undo pages are insufficient, the pages can be imported only from the undo segment having more pages than MINIMUM UNDO PAGE\_COUNT.

## 10.167 NET\_BUFFER\_SIZE

### Basic Information

| Item             | Description                    |
|------------------|--------------------------------|
| Name             | NET_BUFFER_SIZE                |
| Summary          | TCP network buffer size (byte) |
| Data type        | BIGINT                         |
| Applicable phase | NO MOUNT or above              |
| Updatable        | TRUE                           |
| ALTER SESSION    | FALSE                          |
| ALTER SYSTEM     | DEFERRED                       |
| MIN              | 1024                           |
| MAX              | 1073741824                     |
| Default value    | 32768                          |

### Description

It sets the TCP communications buffer size.

In the dedicated mode, it is set to the maximum communication packet size.

In the shared mode, it is set to `DISPATCHER_CM_UNIT_SIZE`.

## 10.168 NLS\_DATE\_FORMAT

### Basic Information

| Item             | Description       |
|------------------|-------------------|
| Name             | NLS_DATE_FORMAT   |
| Summary          | nls date format   |
| Data type        | VARCHAR           |
| Applicable phase | NO MOUNT or above |
| Updatable        | TRUE              |
| ALTER SESSION    | TRUE              |
| ALTER SYSTEM     | FALSE             |
| MIN              | N/A               |
| MAX              | N/A               |
| Default value    | YYYY-MM-DD        |

### Description

NLS\_DATE\_FORMAT specifies the default date format of TO\_CHAR and TO\_DATE functions.



## 10.169 NLS\_TIME\_FORMAT

### Basic Information

| Item             | Description       |
|------------------|-------------------|
| Name             | NLS_TIME_FORMAT   |
| Summary          | nls time format   |
| Data type        | VARCHAR           |
| Applicable phase | NO MOUNT or above |
| Updatable        | TRUE              |
| ALTER SESSION    | TRUE              |
| ALTER SYSTEM     | FALSE             |
| MIN              | N/A               |
| MAX              | N/A               |
| Default value    | HH24:MI:SS.FF6    |

### Description

NLS\_DATE\_FORMAT specifies the default time format of TO\_CHAR and TO\_DATE functions.

## 10.170 NLS\_TIME\_WITH\_TIME\_ZONE\_FORMAT

### Basic Information

| Item             | Description                    |
|------------------|--------------------------------|
| Name             | NLS_TIME_WITH_TIME_ZONE_FORMAT |
| Summary          | nls time with time zone format |
| Data type        | VARCHAR                        |
| Applicable phase | NO MOUNT or above              |
| Updatable        | TRUE                           |
| ALTER SESSION    | TRUE                           |
| ALTER SYSTEM     | FALSE                          |
| MIN              | N/A                            |
| MAX              | N/A                            |
| Default value    | HH24:MI:SS.FF6 TZH:TZM         |

### Description

NLS\_TIME\_WITH\_TIME\_ZONE\_FORMAT specifies the default time with time zone format of TO\_CHAR and TO\_TIME\_WITH\_TIME\_ZONE functions.

## 10.171 NLS\_TIMESTAMP\_FORMAT

### Basic Information

| Item             | Description               |
|------------------|---------------------------|
| Name             | NLS_TIMESTAMP_FORMAT      |
| Summary          | nls timestamp format      |
| Data type        | VARCHAR                   |
| Applicable phase | NO MOUNT or above         |
| Updatable        | TRUE                      |
| ALTER SESSION    | TRUE                      |
| ALTER SYSTEM     | FALSE                     |
| MIN              | N/A                       |
| MAX              | N/A                       |
| Default value    | YYYY-MM-DD HH24:MI:SS.FF6 |

### Description

NLS\_TIMESTAMP\_FORMAT specifies the default timestamp format of TO\_CHAR and TO\_TIMESTAMP functions.

# 10.172 NLS\_TIMESTAMP\_WITH\_TIME\_ZONE\_FORMAT

## Basic Information

| Item             | Description                         |
|------------------|-------------------------------------|
| Name             | NLS_TIMESTAMP_WITH_TIME_ZONE_FORMAT |
| Summary          | nls timestamp with time zone format |
| Data type        | VARCHAR                             |
| Applicable phase | NO MOUNT or above                   |
| Updatable        | TRUE                                |
| ALTER SESSION    | TRUE                                |
| ALTER SYSTEM     | FALSE                               |
| MIN              | N/A                                 |
| MAX              | N/A                                 |
| Default value    | YYYY-MM-DD HH24:MI:SS.FF6 TZH:TZM   |

## Description

NLS\_TIMESTAMP\_WITH\_TIME\_ZONE\_FORMAT specifies the default timestamp with time zone format of TO\_CHAR and TO\_TIMESTAMP WITH TIMEZONE functions.

## 10.173 NUMA

### Basic Information

| Item             | Description |
|------------------|-------------|
| Name             | NUMA        |
| Summary          | enable numa |
| Data type        | BOOLEAN     |
| Applicable phase | NONE        |
| Updatable        | TRUE        |
| ALTER SESSION    | FALSE       |
| ALTER SYSTEM     | FALSE       |
| MIN              | 0           |
| MAX              | 1           |
| Default value    | NO          |

### Description

It enables NUMA.



To use the NUMA property in AIX, the user account should be modified. Execute the following command as a root user.

```
# chuser "capabilities=CAP_NUMA_ATTACH,CAP_PROPAGATE" <username>
```

<username> is not a root but it is a user account of AIX.

Logout then login again to apply the modifications.

# 10.174 NUMA\_MAP

## Basic Information

| Item             | Description      |
|------------------|------------------|
| Name             | NUMA_MAP         |
| Summary          | numa node map    |
| Data type        | VARCHAR          |
| Applicable phase | NONE             |
| Updatable        | TRUE             |
| ALTER SESSION    | FALSE            |
| ALTER SYSTEM     | FALSE            |
| MIN              | N/A              |
| MAX              | N/A              |
| Default value    | 'x' : no binding |

## Description

It sets the map to connect cores of the system to NUMA node. This property is operated when NUMA property is set to on.

The following is an example of the system having four cores.

- Connect core 0 and 1 to number 0 NUMA node, and core 2 and 3 to number 1 NUMA node.

```
NUMA_MAP = '0:0:1:1' # core
```

- Connect core 0 and 1 to number 0 NUMA node, and core 2 and 3 to number 1 NUMA node, and core 1 and 3 to number 2 NUMA node.

```
NUMA_MAP = '0:0,2:1:1,2' # core
```

# 10.175 OFFLINE\_MEMBER\_AFTER\_FAILOVER

## Basic Information

| Item             | Description                                 |
|------------------|---------------------------------------------|
| Name             | OFFLINE_MEMBER_AFTER_FAILOVER               |
| Summary          | Automatically offline member after failover |
| Data type        | BOOLEAN                                     |
| Applicable phase | NO MOUNT or above                           |
| Updatable        | TRUE                                        |
| ALTER SESSION    | FALSE                                       |
| ALTER SYSTEM     | IMMEDIATE                                   |
| MIN              | 0                                           |
| MAX              | 1                                           |
| Default value    | YES                                         |

## Description

The background process automatically takes the errored member offline after completing the failover caused by the node error.

If it is not possible to take the errored member offline because it is set to *NO*, then execute the following syntax before the errored member joins the system again.

```
gSQL> ALTER DATABASE OFFLINE INACTIVE CLUSTER MEMBERS;  
Database altered.
```

# 10.176 ONLINE\_INDEX\_REBUILD\_JOURNAL\_REPLAY\_THRESHOLD

## Basic Information

| Item             | Description                                               |
|------------------|-----------------------------------------------------------|
| Name             | ONLINE_INDEX_REBUILD_JOURNAL_REPLAY_THRESHOLD             |
| Summary          | threshold bytes for replaying journals without table lock |
| Data type        | BIGINT                                                    |
| Applicable phase | NO_MOUNT or above                                         |
| Updatable        | TRUE                                                      |
| ALTER SESSION    | TRUE                                                      |
| ALTER SYSTEM     | IMMEDIATE                                                 |
| MIN              | 0                                                         |
| MAX              | 10737418240                                               |
| Default value    | 1048576                                                   |

## Description

DML performed during rebuilding the index on ONLINE mode records the journal log. The journals are applied to the index multiple times when finishing rebuilding the index. **MAXIMUM\_INDEX\_REBUILD\_JOURNAL\_REPLAY\_COUNT** sets how many times to apply the journal logs. However, if the amount of journal logs to be applied are small, then it is not repeated as many as it is set to be, but instantly set the table the EXCLUSIVE lock, and uses it as the threshold value to apply the last journal log.



# 10.177 ONLINE\_JOURNAL\_REPLAY\_THRESHOLD

## Basic Information

| Item             | Description                                               |
|------------------|-----------------------------------------------------------|
| Name             | ONLINE_JOURNAL_REPLAY_THRESHOLD                           |
| Summary          | threshold bytes for replaying journals without table lock |
| Data type        | BIGINT                                                    |
| Applicable phase | NO_MOUNT or above                                         |
| Updatable        | TRUE                                                      |
| ALTER SESSION    | TRUE                                                      |
| ALTER SYSTEM     | IMMEDIATE                                                 |
| MIN              | 0                                                         |
| MAX              | 10737418240 (10G)                                         |
| Default value    | 1048576 (1M)                                              |

## Description

The table rebalancing online applies journal logs several times which were recorded by dml occurred during the performance in the cluster environment. `MAXIMUM_JOURNAL_REPLAY_COUNT` sets how many times to apply the journal logs. However, if the amount of journal logs to be applied are small, then it is not repeated as many as it is set to be, but instantly set the table the `EXCLUSIVE` lock, and uses it as the threshold value to apply the last journal log.

## 10.178 OS\_GROUP\_ACCESS

### Basic Information

| Item             | Description                                     |
|------------------|-------------------------------------------------|
| Name             | OS_GROUP_ACCESS                                 |
| Summary          | enable access database with OS group permission |
| Data type        | BOOLEAN                                         |
| Applicable phase | NO MOUNT or above                               |
| Updatable        | TRUE                                            |
| ALTER SESSION    | FALSE                                           |
| ALTER SYSTEM     | DEFERRED                                        |
| MIN              | 0                                               |
| MAX              | 1                                               |
| Default value    | NO                                              |

### Description

To connect to DA with another user of the same group, this property should be set to *YES*. Also, the `umask` of the system should be modified to `0002`.

# 10.179 PACKET\_COMPRESSION\_THRESHOLD

## Basic Information

| Item             | Description                                           |
|------------------|-------------------------------------------------------|
| Name             | PACKET_COMPRESSION_THRESHOLD                          |
| Summary          | The size limit at which packets are compressed(bytes) |
| Data type        | BIGINT                                                |
| Applicable phase | NO MOUNT or above                                     |
| Updatable        | TRUE                                                  |
| ALTER SESSION    | TRUE                                                  |
| ALTER SYSTEM     | IMMEDIATE                                             |
| MIN              | 32                                                    |
| MAX              | 2113929216                                            |
| Default value    | 2113929216                                            |

## Description

If the data size to be sent to the client is bigger than `PACKET_COMPRESSION_THRESHOLD`, it compresses the communication data.

## 10.180 PAGE\_CHECKSUM\_TYPE

### Basic Information

| Item             | Description                       |
|------------------|-----------------------------------|
| Name             | PAGE_CHECKSUM_TYPE                |
| Summary          | page checksum type (0:LSN, 1:CRC) |
| Data type        | BIGINT                            |
| Applicable phase | NO MOUNT or above                 |
| Updatable        | TRUE                              |
| ALTER SESSION    | FALSE                             |
| ALTER SYSTEM     | IMMEDIATE                         |
| MIN              | 0                                 |
| MAX              | 1                                 |
| Default value    | 0                                 |

### Description

A checksum is used to guarantee the physical consistency for each page of the datafile. GOLDILOCKS supports a page checksum of LSN, CRC scheme.

- 0: LSN
- 1: CRC

# 10.181 PARALLEL\_IO\_FACTOR

## Basic Information

| Item             | Information          |
|------------------|----------------------|
| Name             | PARALLEL_IO_FACTOR   |
| Summary          | parallel load factor |
| Data type        | BIGINT               |
| Applicable phase | NO MOUNT or below    |
| Updatable        | TRUE                 |
| ALTER SESSION    | FALSE                |
| ALTER SYSTEM     | DEFERRED             |
| MIN              | 1                    |
| MAX              | 16                   |
| Default value    | 1                    |

## Description

It sets the number of threads for the parallel loading of data file when starting database and the number of threads for parallel recording of data file at checkpoint.

## 10.182 PARALLEL\_IO\_GROUP\_1 ~ PARALLEL\_IO\_GROUP\_16

### Basic Information

| Item             | Description           |
|------------------|-----------------------|
| Name             | PARALLEL_IO_GROUP_1   |
| Summary          | parallel load group 1 |
| Data type        | VARCHAR               |
| Applicable phase | NO MOUNT or below     |
| Updatable        | TRUE                  |
| ALTER SESSION    | FALSE                 |
| ALTER SYSTEM     | DEFERRED              |
| MIN              | N/A                   |
| MAX              | N/A                   |
| Default value    | \$GOLDILOCKS_DATA/db  |

### Description

It sets the group directory for parallel I/O of data file. It sets the number of group as many as PARALLEL\_I  
O\_FACTOR, then parallel I/O is performed in data file unit which belongs to each group.

## 10.183 PARALLEL\_LOAD\_FACTOR

### Basic Information

| Item             | Description          |
|------------------|----------------------|
| Name             | PARALLEL_LOAD_FACTOR |
| Summary          | parallel load factor |
| Data type        | BIGINT               |
| Applicable phase | NO MOUNT or below    |
| Updatable        | TRUE                 |
| ALTER SESSION    | FALSE                |
| ALTER SYSTEM     | IMMEDIATE            |
| MIN              | 1                    |
| MAX              | 64                   |
| Default value    | 1                    |

### Description

When starting database, it sets the number of threads for parallel operation after loading the memory of a data file.

## 10.184 PENDING\_LOG\_BUFFER\_COUNT

### Basic Information

| Item             | Description                      |
|------------------|----------------------------------|
| Name             | PENDING_LOG_BUFFER_COUNT         |
| Summary          | default pending log buffer count |
| Data type        | BIGINT                           |
| Applicable phase | NO MOUNT or below                |
| Updatable        | TRUE                             |
| ALTER SESSION    | FALSE                            |
| ALTER SYSTEM     | IMMEDIATE                        |
| MIN              | 0                                |
| MAX              | 32                               |
| Default value    | 4                                |

### Description

When multiple transactions are simultaneously running, the pending log buffer is used to reduce the competition for the log buffer. PENDING LOG\_BUFFER COUNT sets the number of pending log buffer which can be used simultaneously.



# 10.185 PLAN\_CACHE

## Basic Information

| Item             | Description       |
|------------------|-------------------|
| Name             | PLAN_CACHE        |
| Summary          | caching sql plan  |
| Data type        | BOOLEAN           |
| Applicable phase | NO MOUNT or above |
| Updatable        | TRUE              |
| ALTER SESSION    | TRUE              |
| ALTER SYSTEM     | DEFERRED          |
| MIN              | 0                 |
| MAX              | 1                 |
| Default value    | YES               |

## Description

It determines whether to use the plan cache.

## 10.186 PLAN\_CACHE\_SIZE

### Basic Information

| Item             | Description                |
|------------------|----------------------------|
| Name             | PLAN_CACHE_SIZE            |
| Summary          | sql plan cache size (byte) |
| Data type        | BIGINT                     |
| Applicable phase | NONE                       |
| Updatable        | TRUE                       |
| ALTER SESSION    | FALSE                      |
| ALTER SYSTEM     | FALSE                      |
| MIN              | 20971520                   |
| MAX              | 1099511627776              |
| Default value    | 104857600                  |

### Description

It sets the memory size to be used for the plan cache.

# 10.187 PLAN\_HISTORY

## Basic Information

| Item             | Description           |
|------------------|-----------------------|
| Name             | PLAN_HISTORY          |
| Summary          | plan history for SQLs |
| Data type        | BOOLEAN               |
| Applicable phase | NO MOUNT or above     |
| Updatable        | TRUE                  |
| ALTER SESSION    | TRUE                  |
| ALTER SYSTEM     | IMMEDIATE             |
| MIN              | 0                     |
| MAX              | 1                     |
| Default value    | NO                    |

## Description

It sets whether to use the plan history.

## 10.188 PLAN\_HISTORY\_SIZE

### Basic Information

| Item             | Description       |
|------------------|-------------------|
| Name             | PLAN_HISTORY_SIZE |
| Summary          | plan history size |
| Data type        | BIGINT            |
| Applicable phase | NONE              |
| Updatable        | TRUE              |
| ALTER SESSION    | FALSE             |
| ALTER SYSTEM     | DEFERRED          |
| MIN              | 0                 |
| MAX              | 100000            |
| Default value    | 0                 |

### Description

It sets the number of plans to be stored in the plan history.

## 10.189 PRIVATE\_STATIC\_AREA\_INIT\_SIZE

### Basic Information

| Item             | Description                                |
|------------------|--------------------------------------------|
| Name             | PRIVATE_STATIC_AREA_INIT_SIZE              |
| Summary          | Initial size of Private Static Area (byte) |
| Data type        | BIGINT                                     |
| Applicable phase | NO MOUNT or above                          |
| Updatable        | TRUE                                       |
| ALTER SESSION    | FALSE                                      |
| ALTER SYSTEM     | IMMEDIATE                                  |
| MIN              | 1048576                                    |
| MAX              | 34359738368                                |
| Default value    | 10485760                                   |

### Description

It sets the initial size of the heap memory to use in the session. Even when there are memories which are not used in the session, the memories are not returned to operating system.

## 10.190 PRIVATE\_STATIC\_AREA\_NEXT\_SIZE

### Basic Information

| Item             | Description                             |
|------------------|-----------------------------------------|
| Name             | PRIVATE_STATIC_AREA_NEXT_SIZE           |
| Summary          | Next size of Private Static Area (byte) |
| Data type        | BIGINT                                  |
| Applicable phase | NO MOUNT or above                       |
| Updatable        | TRUE                                    |
| ALTER SESSION    | FALSE                                   |
| ALTER SYSTEM     | IMMEDIATE                               |
| MIN              | 1024                                    |
| MAX              | 34359738368                             |
| Default value    | 10485760                                |

### Description

It sets the size of memory to extend when the session allocates additional heap memory.

# 10.191 PRIVATE\_STATIC\_AREA\_SHRINK\_THRESHOLD

## Basic Information

| Item             | Description                                                    |
|------------------|----------------------------------------------------------------|
| Name             | PRIVATE_STATIC_AREA_SHRINK_THRESHOLD                           |
| Summary          | Threshold bytes to attempt to shrink private static area(byte) |
| Data type        | BIGINT                                                         |
| Applicable phase | NO MOUNT or above                                              |
| Updatable        | TRUE                                                           |
| ALTER SESSION    | FALSE                                                          |
| ALTER SYSTEM     | IMMEDIATE                                                      |
| MIN              | 1048576                                                        |
| MAX              | 34359738368                                                    |
| Default value    | 10485760                                                       |

## Description

The memory size is preserved as big as this property even when there are unused heap memories in the session, and those memories are not returned to the system but are reused in the session.

Even when it is set to smaller than PRIVATE\_STATIC\_AREA\_INIT\_SIZE, it is not decreased to smaller than the size.

## 10.192 PRIVATE\_STATIC\_AREA\_SIZE

### Basic Information

| Item             | Description                    |
|------------------|--------------------------------|
| Name             | PRIVATE_STATIC_AREA_SIZE       |
| Summary          | Shared Static Area Size (byte) |
| Data type        | BIGINT                         |
| Applicable phase | NO MOUNT or above              |
| Updatable        | TRUE                           |
| ALTER SESSION    | TRUE                           |
| ALTER SYSTEM     | IMMEDIATE                      |
| MIN              | 104857600                      |
| MAX              | 34359738368                    |
| Default value    | 104857600                      |

### Description

It specifies the maximum heap memory size to be allocated by the session.



## 10.193 PROCESS\_MAX\_COUNT

### Basic Information

| Item             | Description       |
|------------------|-------------------|
| Name             | PROCESS_MAX_COUNT |
| Summary          | Process Max Count |
| Data type        | BIGINT            |
| Applicable phase | NONE              |
| Updatable        | TRUE              |
| ALTER SESSION    | FALSE             |
| ALTER SYSTEM     | FALSE             |
| MIN              | 12                |
| MAX              | 65535             |
| Default value    | 128               |

### Description

It specifies the maximum number of processes (threads) available on the system.

Creating system process

- The process is created each time of connection to D/A mode or C/S dedicated mode.
- In C/S shared mode, processes are basic balancer, dispatcher and shared-server. A process is not created when connecting from client.

# 10.194 QUERY\_TIMEOUT

## Basic Information

| Item             | Description       |
|------------------|-------------------|
| Name             | QUERY_TIMEOUT     |
| Summary          | query timeout (s) |
| Data type        | BIGINT            |
| Applicable phase | NO MOUNT or above |
| Updatable        | TRUE              |
| ALTER SESSION    | TRUE              |
| ALTER SYSTEM     | IMMEDIATE         |
| MIN              | 0                 |
| MAX              | 10000000          |
| Default value    | 0                 |

## Description

It specifies the maximum time which a command received from the session can be executed. If the execution time exceeds, the TIMEOUT error occurs.

- 0: It means infinite waiting, and TIMEOUT error does not occur.

# 10.195 READABLE\_ARCHIVELOG\_DIR\_COUNT

## Basic Information

| Item             | Description                          |
|------------------|--------------------------------------|
| Name             | READABLE_ARCHIVELOG_DIR_COUNT        |
| Summary          | readable archive log directory count |
| Data type        | BIGINT                               |
| Applicable phase | NO MOUNT or above                    |
| Updatable        | TRUE                                 |
| ALTER SESSION    | TRUE                                 |
| ALTER SYSTEM     | DEFERRED                             |
| MIN              | 1                                    |
| MAX              | 10                                   |
| Default value    | 1                                    |

## Description

It sets the number of directories in which archive redo logs exist when executing media recovery.

## 10.196 READABLE\_BACKUP\_DIR\_COUNT

### Basic Information

| Item             | Description                     |
|------------------|---------------------------------|
| Name             | READABLE_BACKUP_DIR_COUNT       |
| Summary          | readable backup directory count |
| Data type        | BIGINT                          |
| Applicable phase | NO MOUNT or above               |
| Updatable        | TRUE                            |
| ALTER SESSION    | TRUE                            |
| ALTER SYSTEM     | DEFERRED                        |
| MIN              | 1                               |
| MAX              | 10                              |
| Default value    | 1                               |

### Description

It sets the number of directories in which incremental backups exist when restoring files using incremental backups.

# 10.197 REBALANCE\_BLOCK\_READ\_COUNT

## Basic Information

| Item             | Description                    |
|------------------|--------------------------------|
| Name             | REBALANCE_BLOCK_READ_COUNT     |
| Summary          | block read count for rebalance |
| Data type        | BIGINT                         |
| Applicable phase | NO MOUNT or above              |
| Updatable        | TRUE                           |
| ALTER SESSION    | TRUE                           |
| ALTER SYSTEM     | DEFERRED                       |
| MIN              | 1                              |
| MAX              | 65536                          |
| Default value    | 1                              |

## Description

It is the block read count for rebalance.

# 10.198 RECOMPILE\_CHECK\_MINIMUM\_PAGE\_COUNT



It is not supported after 3.1.

## Basic Information

| Item             | Description                            |
|------------------|----------------------------------------|
| Name             | RECOMPILE_CHECK_MINIMUM_PAGE_COUNT     |
| Summary          | minimum page count for recompile check |
| Data type        | BIGINT                                 |
| Applicable phase | NO MOUNT or above                      |
| Updatable        | TRUE                                   |
| ALTER SESSION    | TRUE                                   |
| ALTER SYSTEM     | IMMEDIATE                              |
| MIN              | 1                                      |
| MAX              | 10000                                  |
| Default value    | 64                                     |

## Description

It sets the minimum page count to check if the plan is recompiled due to the page count modification.

# 10.199 RECOMPILE\_PAGE\_PERCENT



It is not supported after 3.1.

## Basic Information

| Item             | Description            |
|------------------|------------------------|
| Name             | RECOMPILE_PAGE_PERCENT |
| Summary          | recompile page percent |
| Data type        | BIGINT                 |
| Applicable phase | NO MOUNT or above      |
| Updatable        | TRUE                   |
| ALTER SESSION    | TRUE                   |
| ALTER SYSTEM     | IMMEDIATE              |
| MIN              | 0                      |
| MAX              | 1000                   |
| Default value    | 30                     |

## Description

It sets the page percentage when recompiles the plan due to the page count modification. If its value is 0, it does not recompile due to the page count modification.

## 10.200 RECOVERY\_LOG\_BUFFER\_SIZE

### Basic Information

| Item             | Description                          |
|------------------|--------------------------------------|
| Name             | RECOVERY_LOG_BUFFER_SIZE             |
| Summary          | default log buffer size for recovery |
| Data type        | BIGINT                               |
| Applicable phase | NO MOUNT or above                    |
| Updatable        | TRUE                                 |
| ALTER SESSION    | TRUE                                 |
| ALTER SYSTEM     | IMMEDIATE                            |
| MIN              | 786432                               |
| MAX              | 32 Mega                              |
| Default value    | 10 Mega                              |

### Description

It is the default log buffer size for recovery.



## 10.201 RECYCLEBIN

### Basic Information

| Item             | Description                          |
|------------------|--------------------------------------|
| Name             | RECYCLEBIN                           |
| Summary          | enable or disable recyclebin feature |
| Data type        | BOOLEAN                              |
| Applicable phase | NO_MOUNT or above                    |
| Updatable        | TRUE                                 |
| ALTER SESSION    | TRUE                                 |
| ALTER SYSTEM     | DEFERRED                             |
| MIN              | 0                                    |
| MAX              | 1                                    |
| Default value    | NO                                   |

### Description

It sets whether to activate the recyclebin feature.

## 10.202 REDO\_LOG\_COMPRESSION\_THRESHOLD

### Basic Information

| Item             | Description                                            |
|------------------|--------------------------------------------------------|
| Name             | REDO_LOG_COMPRESSION_THRESHOLD                         |
| Summary          | The size limit at which redo log are compressed(bytes) |
| Data type        | BIGINT                                                 |
| Applicable phase | NO MOUNT or above                                      |
| Updatable        | TRUE                                                   |
| ALTER SESSION    | FALSE                                                  |
| ALTER SYSTEM     | IMMEDIATE                                              |
| MIN              | 32                                                     |
| MAX              | 2113929216                                             |
| Default value    | 2113929216                                             |

### Description

If the size of the created REDO LOG is bigger than REDO\_LOG\_COMPRESSION\_THRESHOLD value, it compresses REDO LOG.

## 10.203 REFINE\_RELATION

### Basic Information

| Item             | Description           |
|------------------|-----------------------|
| Name             | REFINE_RELATION       |
| Summary          | refine aged relations |
| Data type        | BOOLEAN               |
| Applicable phase | NO MOUNT or above     |
| Updatable        | TRUE                  |
| ALTER SESSION    | FALSE                 |
| ALTER SYSTEM     | IMMEDIATE             |
| MIN              | 0                     |
| MAX              | 1                     |
| Default value    | YES                   |

### Description

If this property is set to NO, then REFINE RELATION process is not performed when restarting the server.

This property can be used when an error occurs during the REFINE RELATION process. However, segments of RELATIONS (tables or indexes) which were dropped but not REFINEd can not be reused. When resolving the error then setting this property to YES and restarting, it tries to REFINE relations which were not dropped.

## 10.204 SESSION\_FATAL\_BEHAVIOR

### Basic Information

| Item             | Description            |
|------------------|------------------------|
| Name             | SESSION_FATAL_BEHAVIOR |
| Summary          | session fatal behavior |
| Data type        | BIGINT                 |
| Applicable phase | NO MOUNT or above      |
| Updatable        | TRUE                   |
| ALTER SESSION    | FALSE                  |
| ALTER SYSTEM     | IMMEDIATE              |
| MIN              | 0                      |
| MAX              | 1                      |
| Default value    | 0                      |

### Description

When session fatal occurs, it determines whether to terminate only the thread which caused the fatal or to terminate the process.

- 0: It terminates only the thread which caused fatal.
- 1: It terminates the process.

If multiple sessions are simultaneously performed in the process, the process is terminated after all sessions finish using database.

## 10.205 SESSION\_MEMORY\_INIT\_SIZE

### Basic Information

| Item             | Description                     |
|------------------|---------------------------------|
| Name             | SESSION_MEMORY_INIT_SIZE        |
| Summary          | initial memory size for session |
| Data type        | BIGINT                          |
| Applicable phase | NO MOUNT or above               |
| Updatable        | TRUE                            |
| ALTER SESSION    | FALSE                           |
| ALTER SYSTEM     | IMMEDIATE                       |
| MIN              | 131072 (128K)                   |
| MAX              | 1073741824 (1G)                 |
| Default value    | 131072 (128K)                   |

### Description

It sets the shared memory size to be allocated in advance so that it can be used in the session.

## 10.206 SESSION\_MEMORY\_SHRINK\_THRESHOLD

### Basic Information

| Item             | Description                                                            |
|------------------|------------------------------------------------------------------------|
| Name             | SESSION_MEMORY_SHRINK_THRESHOLD                                        |
| Summary          | threshold bytes to attempt to shrink session memory allocator ( byte ) |
| Data type        | BIGINT                                                                 |
| Applicable phase | NO MOUNT or above                                                      |
| Updatable        | TRUE                                                                   |
| ALTER SESSION    | FALSE                                                                  |
| ALTER SYSTEM     | IMMEDIATE                                                              |
| MIN              | 131072 (128K)                                                          |
| MAX              | 1073741824 (1G)                                                        |
| Default value    | 131072 (128K)                                                          |

### Description

It sets the threshold value to determine whether to return the dynamic shared memory which is not used by the session to the system when releasing the dynamic shared memory used in the session. In other words, if the memory chunk which is bigger than the set value among unused memory exists, then it is returned to the system.

## 10.207 SHARED\_MEMORY\_ADDRESS

### Basic Information

| Item             | Description           |
|------------------|-----------------------|
| Name             | SHARED_MEMORY_ADDRESS |
| Summary          | shared memory address |
| Data type        | BIGINT                |
| Applicable phase | NONE                  |
| Updatable        | TRUE                  |
| ALTER SESSION    | FALSE                 |
| ALTER SYSTEM     | FALSE                 |
| MIN              | N/A                   |
| MAX              | N/A                   |
| Default value    | 1610612736            |

### Description

It specifies the address of Shared Static Area (SSA).

## 10.208 SHARED\_MEMORY\_STATIC\_KEY

### Basic Information

| Item             | Description              |
|------------------|--------------------------|
| Name             | SHARED_MEMORY_STATIC_KEY |
| Summary          | Shared Memory Static KEY |
| Data type        | BIGINT                   |
| Applicable phase | NONE                     |
| Updatable        | TRUE                     |
| ALTER SESSION    | FALSE                    |
| ALTER SYSTEM     | FALSE                    |
| MIN              | N/A                      |
| MAX              | N/A                      |
| Default value    | 542353                   |

### Description

When running server, it specifies the shared memory key values which are used to allocate Static Shared Area (SSA) space.



## 10.209 SHARED\_MEMORY\_STATIC\_NAME

### Basic Information

| Item             | Description               |
|------------------|---------------------------|
| Name             | SHARED_MEMORY_STATIC_NAME |
| Summary          | Shared Memory Static Name |
| Data type        | VARCHAR                   |
| Applicable phase | NONE                      |
| Updatable        | TRUE                      |
| ALTER SESSION    | FALSE                     |
| ALTER SYSTEM     | FALSE                     |
| MIN              | N/A                       |
| MAX              | N/A                       |
| Default value    | _STATIC                   |

### Description

When running server, it specifies the shared memory name which is used to allocate Static Shared Area (S SA) space.

## 10.210 SHARED\_MEMORY\_STATIC\_SIZE

### Basic Information

| Item             | Description                      |
|------------------|----------------------------------|
| Name             | SHARED_MEMORY_STATIC_SIZE        |
| Summary          | Shared Memory Static Size (byte) |
| Data type        | BIGINT                           |
| Applicable phase | NONE                             |
| Updatable        | TRUE                             |
| ALTER SESSION    | FALSE                            |
| ALTER SYSTEM     | FALSE                            |
| MIN              | 104857600                        |
| MAX              | 1099511627776                    |
| Default value    | 629145600                        |

### Description

It specifies the size of the Shared Static Area (SSA).

## 10.211 SHARED\_REQUEST\_QUEUE\_COUNT

### Basic Information

| Item             | Description                   |
|------------------|-------------------------------|
| Name             | SHARED_REQUEST_QUEUE_COUNT    |
| Summary          | count of global request queue |
| Data type        | BIGINT                        |
| Applicable phase | NONE                          |
| Updatable        | TRUE                          |
| ALTER SESSION    | FALSE                         |
| ALTER SYSTEM     | FALSE                         |
| MIN              | 1                             |
| MAX              | 16                            |
| Default value    | 1                             |

### Description

In shared mode, it sets the number of queues of which the dispatcher requests to the shared-server. A queue is used when multiple dispatchers allocate user's requests to the shared-server. Generally, a single queue is used for the load-balance.

However, SHARED\_REQUEST\_QUEUE\_COUNT value is increased because if the number of dispatchers and shared-servers increase, then a conflict to the queue causes performance degradation.

If the value becomes bigger, the load-balance can be inefficient and the possibility of deadlock increases.

## 10.212 SHARED\_SERVERS

### Basic Information

| Item             | Description                       |
|------------------|-----------------------------------|
| Name             | SHARED_SERVERS                    |
| Summary          | number of shared-server processes |
| Data type        | BIGINT                            |
| Applicable phase | NO MOUNT or above                 |
| Updatable        | TRUE                              |
| ALTER SESSION    | FALSE                             |
| ALTER SYSTEM     | IMMEDIATE                         |
| MIN              | 1                                 |
| MAX              | 2048                              |
| Default value    | 10                                |

### Description

It sets the number of shared-server processes on shared mode.

At open phase, the value can not be decreased by using alter system.

## 10.213 SHARED\_SESSION

### Basic Information

| Item             | Description              |
|------------------|--------------------------|
| Name             | SHARED_SESSION           |
| Summary          | to enable shared session |
| Data type        | BOOL                     |
| Applicable phase | MOUNT or below           |
| Updatable        | TRUE                     |
| ALTER SESSION    | FALSE                    |
| ALTER SYSTEM     | IMMEDIATE                |
| MIN              | 0                        |
| MAX              | 1                        |
| Default value    | YES                      |

### Description

It sets whether to activate shared mode. If the value is set to *NO*, load-balancer (gbalancer), dispatcher (g dispatcher), shared-server (gserver) are not executed.

## 10.214 SNAPSHOT\_STATEMENT\_TIMEOUT

### Basic Information

| Item             | Description                    |
|------------------|--------------------------------|
| Name             | SNAPSHOT_STATEMENT_TIMEOUT     |
| Summary          | snapshot statement timeout (s) |
| Data type        | BIGINT                         |
| Applicable phase | NO MOUNT or above              |
| Updatable        | TRUE                           |
| ALTER SESSION    | FALSE                          |
| ALTER SYSTEM     | IMMEDIATE                      |
| MIN              | 1                              |
| MAX              | 22118400 (1 year)              |
| Default value    | 22118400 (1 year)              |

### Description

It sets the maximum holding time of the statement required for the snapshot read. TIMEOUT error occurs for a snapshot statement which exceeds the time.

## 10.215 SQL\_HISTORY\_SIZE

### Basic Information

| Item             | Description           |
|------------------|-----------------------|
| Name             | SQL_HISTORY_SIZE      |
| Summary          | history size for SQLs |
| Data type        | BIGINT                |
| Applicable phase | NO MOUNT or above     |
| Updatable        | TRUE                  |
| ALTER SESSION    | FALSE                 |
| ALTER SYSTEM     | DEFERRED              |
| MIN              | 0                     |
| MAX              | 100000                |
| Default value    | 0                     |

### Description

It is the history size for SQLs.

## 10.216 SQL\_HISTORY\_TYPE

### Basic Information

| Item             | Description           |
|------------------|-----------------------|
| Name             | SQL_HISTORY_TYPE      |
| Summary          | history type for SQLs |
| Data type        | BIGINT                |
| Applicable phase | NO MOUNT or above     |
| Updatable        | TRUE                  |
| ALTER SESSION    | TRUE                  |
| ALTER SYSTEM     | IMMEDIATE             |
| MIN              | 0                     |
| MAX              | 2                     |
| Default value    | 0                     |

### Description

It is the history type for SQLs.

- 0: Direct-execute
- 1: Prepare-execute
- 2: All



# 10.217 SUPPLEMENTAL\_LOG\_DATA\_PRIMARY\_KEY

## Basic Information

| Item             | Description                                                              |
|------------------|--------------------------------------------------------------------------|
| Name             | SUPPLEMENTAL_LOG_DATA_PRIMARY_KEY                                        |
| Summary          | supplemental log data of primary key columns be logged in redo log files |
| Data type        | BOOLEAN                                                                  |
| Applicable phase | MOUNT or below                                                           |
| Updatable        | TRUE                                                                     |
| ALTER SESSION    | FALSE                                                                    |
| ALTER SYSTEM     | IMMEDIATE                                                                |
| MIN              | 0                                                                        |
| MAX              | 1                                                                        |
| Default value    | NO                                                                       |

## Description

It records supplemental log for all changes in the database.

## 10.218 SYSTEM\_DISK\_DATA\_TABLESPACE\_SIZE

### Basic Information

| Item             | Description                                    |
|------------------|------------------------------------------------|
| Name             | SYSTEM_DISK_DATA_TABLESPACE_SIZE               |
| Summary          | default system disk data tablespace size(byte) |
| Data type        | BIGINT                                         |
| Applicable phase | NONE                                           |
| Updatable        | FALSE                                          |
| ALTER SESSION    | FALSE                                          |
| ALTER SYSTEM     | NONE                                           |
| MIN              | 32 Mega                                        |
| MAX              | 30 Giga                                        |
| Default value    | 200 Mega                                       |

### Description

It sets the initial DISK\_DATA\_TBS tablespace size when creating the database.

## 10.219 SYSTEM\_FILE\_IO

### Basic Information

| Item             | Description                                               |
|------------------|-----------------------------------------------------------|
| Name             | SYSTEM_FILE_IO                                            |
| Summary          | i/o type for system file ( 0: direct io, 1: buffered io ) |
| Data type        | BIGINT                                                    |
| Applicable phase | NO MOUNT or above                                         |
| Updatable        | TRUE                                                      |
| ALTER SESSION    | FALSE                                                     |
| ALTER SYSTEM     | IMMEDIATE                                                 |
| MIN              | 0                                                         |
| MAX              | 1                                                         |
| Default value    | 0                                                         |

### Description

It sets IO type of when using the database file except for the data file and the log file.

## 10.220 SYSTEM\_LOGGER\_DIR

### Basic Information

| Item             | Description             |
|------------------|-------------------------|
| Name             | SYSTEM_LOGGER_DIR       |
| Summary          | system logger directory |
| Data type        | VARCHAR                 |
| Applicable phase | NONE                    |
| Updatable        | TRUE                    |
| ALTER SESSION    | FALSE                   |
| ALTER SYSTEM     | FALSE                   |
| MIN              | N/A                     |
| MAX              | N/A                     |
| Default value    | \$GOLDILOCKS_DATA/trc   |

### Description

It sets the disk path on which the trace log message is recorded.

# 10.221 SYSTEM\_MEMORY\_AUX\_TABLESPACE\_SIZE

## Basic Information

| Item             | Description                                            |
|------------------|--------------------------------------------------------|
| Name             | SYSTEM_MEMORY_AUX_TABLESPACE_SIZE                      |
| Summary          | default system memory auxiliary tablespace size (byte) |
| Data type        | BIGINT                                                 |
| Applicable phase | NONE                                                   |
| Updatable        | FALSE                                                  |
| ALTER SESSION    | FALSE                                                  |
| ALTER SYSTEM     | NONE                                                   |
| MIN              | 32 Mega                                                |
| MAX              | 30 Giga                                                |
| Default value    | 200 Mega                                               |

## Description

It determines the size of initial MEM\_AUX\_TBS tablespace when creating the database.

## 10.222 SYSTEM\_MEMORY\_DATA\_TABLESPACE\_SIZE

### Basic Information

| Item             | Description                                       |
|------------------|---------------------------------------------------|
| Name             | SYSTEM_MEMORY_DATA_TABLESPACE_SIZE                |
| Summary          | default system memory data tablespace size (byte) |
| Data type        | BIGINT                                            |
| Applicable phase | NONE                                              |
| Updatable        | FALSE                                             |
| ALTER SESSION    | FALSE                                             |
| ALTER SYSTEM     | NONE                                              |
| MIN              | 32 Mega                                           |
| MAX              | 30 Giga                                           |
| Default value    | 200 Mega                                          |

### Description

It determines the initial tablespace size of MEM\_DATA\_TBS when creating database.

# 10.223 SYSTEM\_MEMORY\_DICT\_TABLESPACE\_SIZE

## Basic Information

| Item             | Description                               |
|------------------|-------------------------------------------|
| Name             | SYSTEM_MEMORY_DICT_TABLESPACE_SIZE        |
| Summary          | default dictionary tablespace size (byte) |
| Data type        | BIGINT                                    |
| Applicable phase | NONE                                      |
| Updatable        | FALSE                                     |
| ALTER SESSION    | FALSE                                     |
| ALTER SYSTEM     | NONE                                      |
| MIN              | 256 Mega                                  |
| MAX              | 30 Giga                                   |
| Default value    | 256 Mega                                  |

## Description

It determines the initial tablespace size of DICTONARY\_TBS when creating database.

## 10.224 SYSTEM\_MEMORY\_TEMP\_TABLESPACE\_SIZE

### Basic Information

| Item             | Description                                            |
|------------------|--------------------------------------------------------|
| Name             | SYSTEM_MEMORY_TEMP_TABLESPACE_SIZE                     |
| Summary          | default system memory temporary tablespace size (byte) |
| Data type        | BIGINT                                                 |
| Applicable phase | NONE                                                   |
| Updatable        | FALSE                                                  |
| ALTER SESSION    | FALSE                                                  |
| ALTER SYSTEM     | NONE                                                   |
| MIN              | 32 Mega                                                |
| MAX              | 30 Giga                                                |
| Default value    | 200 Mega                                               |

### Description

It determines the initial tablespace size of MEM\_TEMP\_TBS when creating database.



# 10.225 SYSTEM\_MEMORY\_UNDO\_TABLESPACE\_SIZE

## Basic Information

| Item             | Description                                       |
|------------------|---------------------------------------------------|
| Name             | SYSTEM_MEMORY_UNDO_TABLESPACE_SIZE                |
| Summary          | default system memory undo tablespace size (byte) |
| Data type        | BIGINT                                            |
| Applicable phase | NONE                                              |
| Updatable        | FALSE                                             |
| ALTER SESSION    | FALSE                                             |
| ALTER SYSTEM     | NONE                                              |
| MIN              | 32 Mega                                           |
| MAX              | 30 Giga                                           |
| Default value    | 32 Mega                                           |

## Description

It determines the initial tablespace size of MEM\_UNDO\_TBS when creating database.

## 10.226 SYSTEM\_TABLESPACE\_DIR

### Basic Information

| Item             | Description                 |
|------------------|-----------------------------|
| Name             | SYSTEM_TABLESPACE_DIR       |
| Summary          | system tablespace directory |
| Data type        | VARCHAR                     |
| Applicable phase | NO MOUNT or above           |
| Updatable        | TRUE                        |
| ALTER SESSION    | FALSE                       |
| ALTER SYSTEM     | DEFERRED                    |
| MIN              | N/A                         |
| MAX              | N/A                         |
| Default value    | \$(GOLDILOCKS_DATA)/db      |

### Description

It sets the path to which the initial system tablespaces are stored when creating database.

## 10.227 SYSTEM\_UDS\_DIR

### Basic Information

| Item             | Description                         |
|------------------|-------------------------------------|
| Name             | SYSTEM_UDS_DIR                      |
| Summary          | system unix domain socket directory |
| Data type        | VARCHAR                             |
| Applicable phase | NONE                                |
| Updatable        | TRUE                                |
| ALTER SESSION    | FALSE                               |
| ALTER SYSTEM     | FALSE                               |
| MIN              | N/A                                 |
| MAX              | N/A                                 |
| Default value    | '/tmp'                              |

### Description

It sets a directory on which the unix domain socket file is created.

Setting the directory for the unix domain socket except for DB system, such asglsnr, is managed by a separate configuration file.

The maximum setting value is 60 bytes. (The maximum size of the absolute path (directory + file name) for the unix domain socket file varies according to OS, but generally it is around 100 bytes.)

## 10.228 TCP\_CLIENT\_NUMA\_NODE

### Basic Information

| Item             | Description               |
|------------------|---------------------------|
| Name             | TCP_CLIENT_NUMA_NODE      |
| Summary          | numa node for TCP clients |
| Data type        | BIGINT                    |
| Applicable phase | NONE                      |
| Updatable        | TRUE                      |
| ALTER SESSION    | FALSE                     |
| ALTER SYSTEM     | FALSE                     |
| MIN              | -1                        |
| MAX              | 63                        |
| Default value    | -1                        |

### Description

It sets the NUMA node ID to which the client server session is bound. This property is operated when NUMA property is set to on.

## 10.229 TCP\_NODELAY

### Basic Information

| Item             | Description                                                   |
|------------------|---------------------------------------------------------------|
| Name             | TCP_NODELAY                                                   |
| Summary          | no delays in buffer flushing within the TCP/IP protocol stack |
| Data type        | BOOLEAN                                                       |
| Applicable phase | NO MOUNT or above                                             |
| Updatable        | TRUE                                                          |
| ALTER SESSION    | FALSE                                                         |
| ALTER SYSTEM     | DEFERRED                                                      |
| MIN              | 0                                                             |
| MAX              | 1                                                             |
| Default value    | YES                                                           |

### Description

It sets TCP\_NODELAY option of the socket when transferring the data to a client in C/S method (TCP socket).

Set it to *NO* when fast latency is not required and reducing the network load is needed.

## 10.230 TEMP\_SEGMENT\_CACHE\_SIZE

### Basic Information

| Item             | Description                                                                                 |
|------------------|---------------------------------------------------------------------------------------------|
| Name             | TEMP_SEGMENT_CACHE_SIZE                                                                     |
| Summary          | the number of segments to be cached for global temporary tables and indexes in each session |
| Data type        | BIGINT                                                                                      |
| Applicable phase | NO MOUNT or above                                                                           |
| Updatable        | TRUE                                                                                        |
| ALTER SESSION    | FALSE                                                                                       |
| ALTER SYSTEM     | DEFERRED                                                                                    |
| MIN              | 0                                                                                           |
| MAX              | 4294967295                                                                                  |
| Default value    | 3                                                                                           |

### Description

It sets the number of segments to be cached in a session instead of returning them to a tablespace when dropping a global temporary table or a global temporary index segment. Segments in the segment cache are reused later in a global temporary table or a global temporary index.

- 0: It does not use a segment cache of a global temporary table or of a global temporary index in a session.
- 1 ~ 4294967295: It keeps the specific number of segment caches of a global temporary table or a global temporary index in a session.

## 10.231 TEMP\_UNDO\_ENABLED

### Basic Information

| Item             | Description                                                                    |
|------------------|--------------------------------------------------------------------------------|
| Name             | TEMP_UNDO_ENABLED                                                              |
| Summary          | enables writing undo records of global temporary tables to the temp tablespace |
| Data type        | BOOLEAN                                                                        |
| Applicable phase | NO MOUNT or above                                                              |
| Updatable        | TRUE                                                                           |
| ALTER SESSION    | TRUE                                                                           |
| ALTER SYSTEM     | IMMEDIATE                                                                      |
| MIN              | 0                                                                              |
| MAX              | 1                                                                              |
| Default value    | 0                                                                              |

### Description

It defines the location of logging undo records for a global temporary table.

- 0 (FALSE): It records the undo records in the default undo tablespace of database.
- 1 (TRUE): It records the undo records in the default temporary tablespace of database.

## 10.232 TIMED\_STATISTICS

### Basic Information

| Item             | Description       |
|------------------|-------------------|
| Name             | TIMED_STATISTICS  |
| Summary          | timed statistics  |
| Data type        | BIGINT            |
| Applicable phase | NO MOUNT or above |
| Updatable        | TRUE              |
| ALTER SESSION    | TRUE              |
| ALTER SYSTEM     | IMMEDIATE         |
| MIN              | 0                 |
| MAX              | 2                 |
| Default value    | 0                 |

### Description

It is whether to check the wait event.

To record the statistics related to wait event on v\$system\_event, v\$session\_event and v\$session\_wait table, set this property.

- 0: It does not record the statistics.
- 1: It records the statistics.
- 2: It records the statistics by using the high precision timer.



## 10.233 TIMER\_INTERVAL

### Basic Information

| Item             | Description             |
|------------------|-------------------------|
| Name             | TIMER_INTERVAL          |
| Summary          | timer interval time(us) |
| Data type        | BIGINT                  |
| Applicable phase | NO MOUNT or above       |
| Updatable        | TRUE                    |
| ALTER SESSION    | FALSE                   |
| ALTER SYSTEM     | IMMEDIATE               |
| MIN              | 10                      |
| MAX              | 100000                  |
| Default value    | 10000                   |

### Description

It sets the time interval which is required when the timer thread sets the system time.

## 10.234 TIMEZONE

### Basic Information

| Item             | Description |
|------------------|-------------|
| Name             | TIMEZONE    |
| Summary          | timezone    |
| Data type        | VARCHAR     |
| Applicable phase | NONE        |
| Updatable        | FALSE       |
| ALTER SESSION    | FALSE       |
| ALTER SYSTEM     | FALSE       |
| MIN              | N/A         |
| MAX              | N/A         |
| Default value    | +09:00      |

### Description

It is a time zone value of database.

It is applied when creating database, and it uses the value of the range from '-14:00' to '+14:00'.

## 10.235 TRACE\_ALTER\_SYSTEM

### Basic Information

| Item             | Description                           |
|------------------|---------------------------------------|
| Name             | TRACE_ALTER_SYSTEM                    |
| Summary          | write trace messages for ALTER SYSTEM |
| Data type        | BOOLEAN                               |
| Applicable phase | NO MOUNT or above                     |
| Updatable        | TRUE                                  |
| ALTER SESSION    | FALSE                                 |
| ALTER SYSTEM     | IMMEDIATE                             |
| MIN              | 0                                     |
| MAX              | 1                                     |
| Default value    | NO                                    |

### Description

It records the SQL statements in trace file (\$GOLDILOCKS\_DATA/trc/system.trc) when executing ALTER SYSTEM syntax.

Set TRACE\_ALTER\_SYSTEM property to *ON* to record system changes.

SELECT inquiry, and execution of INSERT, UPDATE, DELETE syntax have nothing to do with TRACE\_ALTER\_SYSTEM property, so they do not affect the performance of TRACE\_ALTER\_SYSTEM.

## 10.236 TRACE\_DDL

### Basic Information

| Item             | Description                  |
|------------------|------------------------------|
| Name             | TRACE_DDL                    |
| Summary          | write trace messages for DDL |
| Data type        | BOOLEAN                      |
| Applicable phase | NO MOUNT or above            |
| Updatable        | TRUE                         |
| ALTER SESSION    | TRUE                         |
| ALTER SYSTEM     | IMMEDIATE                    |
| MIN              | 0                            |
| MAX              | 1                            |
| Default value    | NO                           |

### Description

When executing DDL, it records the executed SQL statements in trace file (\$GOLDILOCKS\_DATA/trc/system.trc).

Set *TRACE\_ALTER\_SYSTEM* property to *ON* to record SQL statements execution such as CREATE/DROP/ALTER table.

TRACE\_DDL property affects only to DDL statements. However, it has nothing to do with SELECT inquiry, and execution of INSERT, UPDATE, DELETE syntax. Therefore, it does not affect the performance.

## 10.237 TRACE\_LOG\_ID

### Basic Information

| Item             | Description       |
|------------------|-------------------|
| Name             | TRACE_LOG_ID      |
| Summary          | trace log ID      |
| Data type        | BIGINT            |
| Applicable phase | NO MOUNT or above |
| Updatable        | TRUE              |
| ALTER SESSION    | TRUE              |
| ALTER SYSTEM     | IMMEDIATE         |
| MIN              | 0                 |
| MAX              | 100000000         |
| Default value    | 0                 |

### Description

The execution plan for the query, and other related information are recorded in the trace file (opt\_p[process ID\_s [session ID].trc) under the trace directory (\$GOLDILOCKS\_DATA/trc/) when processing queries.

To record SQL statement for the query, the execution plan and the execution time, refer to the following flag information.

**Table 10-1** Flag information for TRACE\_LOG\_ID

| Information                                           | Flag(on) | Flag(off) |
|-------------------------------------------------------|----------|-----------|
| Whether to output the successful SQL query            | 100000   | 0         |
| Whether to output the failed SQL query                | 10000    | 0         |
| Whether to output the execution plan                  | 1000     | 0         |
| Whether to output the execution type (direct/prepare) | 100      | 0         |
| Whether to output the bind value                      | 10       | 0         |
| Whether to output the execution time per section      | 1        | 0         |

To set it in a form of "output the successful SQL query" + "output the execution plan" + "output the bind value", set the TRACE\_LOG\_ID value to 101010.

## 10.238 TRACE\_LOG\_MSGBUF\_SIZE

### Basic Information

| Item             | Description                              |
|------------------|------------------------------------------|
| Name             | TRACE_LOG_MSGBUF_SIZE                    |
| Summary          | memory buffer size for trace log message |
| Data type        | BIGINT                                   |
| Applicable phase | NONE                                     |
| Updatable        | TRUE                                     |
| ALTER SESSION    | FALSE                                    |
| ALTER SYSTEM     | FALSE                                    |
| MIN              | 8192                                     |
| MAX              | 10485760                                 |
| Default value    | 24576                                    |

### Description

It sets the size of the heap memory buffer which is used to configure the log message to be recorded in the trace logfile.

## 10.239 TRACE\_LOG\_TIME\_DETAIL

### Basic Information

| Item             | Description           |
|------------------|-----------------------|
| Name             | TRACE_LOG_TIME_DETAIL |
| Summary          | detail trace log time |
| Data type        | BOOLEAN               |
| Applicable phase | NO MOUNT or above     |
| Updatable        | TRUE                  |
| ALTER SESSION    | TRUE                  |
| ALTER SYSTEM     | IMMEDIATE             |
| MIN              | 0                     |
| MAX              | 1                     |
| Default value    | NO                    |

### Description

It sets whether to increase the time accuracy when recording trace log.

If the value is ON, it has an accuracy of 1 us.

If the value is OFF, it has an accuracy of 10 ms.

## 10.240 TRACE\_LOGGER

### Basic Information

| Item             | Description                                |
|------------------|--------------------------------------------|
| Name             | TRACE_LOGGER                               |
| Summary          | trace log type ( 1:file, 2:file & remote ) |
| Data type        | BIGINT                                     |
| Applicable phase | NONE                                       |
| Updatable        | TRUE                                       |
| ALTER SESSION    | FALSE                                      |
| ALTER SYSTEM     | IMMEDIATE                                  |
| MIN              | 1                                          |
| MAX              | 2                                          |
| Default value    | 1                                          |

### Description

It sets the target on which the trace log is written.

If it is 1, then it is recorded in a file, and if it is 2, then it is remotely recorded in a file.

When it is remotely written, then it remotely collects trace logs from gtrclogger and records in a file.



## 10.241 TRACE\_LOGGER\_REMOTE\_HOST

### Basic Information

| Item             | Description                  |
|------------------|------------------------------|
| Name             | TRACE_LOGGER_REMOTE_HOST     |
| Summary          | remote host for trace logger |
| Data type        | BIGINT                       |
| Applicable phase | NONE                         |
| Updatable        | TRUE                         |
| ALTER SESSION    | FALSE                        |
| ALTER SYSTEM     | IMMEDIATE                    |
| MIN              | 0                            |
| MAX              | 255255255255                 |
| Default value    | 127000000001                 |

### Description

It sets the host to which the trace log is remotely transferred by setting TRACE\_LOGGER to 2.

## 10.242 TRACE\_LOGGER\_REMOTE\_PORT

### Basic Information

| Item             | Description                  |
|------------------|------------------------------|
| Name             | TRACE_LOGGER_REMOTE_PORT     |
| Summary          | remote port for trace logger |
| Data type        | BIGINT                       |
| Applicable phase | NONE                         |
| Updatable        | TRUE                         |
| ALTER SESSION    | FALSE                        |
| ALTER SYSTEM     | IMMEDIATE                    |
| MIN              | 1024                         |
| MAX              | 49151                        |
| Default value    | 21470                        |

### Description

It sets the port to which the trace log is remotely transferred by setting TRACE\_LOGGER to 2.

## 10.243 TRACE\_LOGIN

### Basic Information

| Item             | Description                         |
|------------------|-------------------------------------|
| Name             | TRACE_LOGIN                         |
| Summary          | write login trace messages for user |
| Data type        | BOOLEAN                             |
| Applicable phase | NO MOUNT or above                   |
| Updatable        | TRUE                                |
| ALTER SESSION    | FALSE                               |
| ALTER SYSTEM     | IMMEDIATE                           |
| MIN              | 0                                   |
| MAX              | 1                                   |
| Default value    | NO                                  |

### Description

It records the related access information in trace file (\$GOLDILOCKS\_DATA/trc/login.trc) on login. Set TRACE\_LOGIN property to *ON* to record the related information on login.

## 10.244 TRACE\_LONG\_RUN\_CURSOR

### Basic Information

| Item             | Description                                                                      |
|------------------|----------------------------------------------------------------------------------|
| Name             | TRACE_LONG_RUN_CURSOR                                                            |
| Summary          | write trace SQL for cursor life-time over specific time (mili-sec. 0 ~ 10000000) |
| Data type        | BIGINT                                                                           |
| Applicable phase | NO MOUNT or above                                                                |
| Updatable        | TRUE                                                                             |
| ALTER SESSION    | TRUE                                                                             |
| ALTER SYSTEM     | IMMEDIATE                                                                        |
| MIN              | 0                                                                                |
| MAX              | 10000000                                                                         |
| Default value    | 0                                                                                |

### Description

When cursor life-time is longer than the specified property time, then it records the SQL statement of the cursor in the trace file (\$GOLDILOCKS\_DATA/trc/system.trc).

- Description of value
  - Unit: millisecond
  - Value 0: It does not record information.
  - Recommended value: 20 (millisecond) or longer
  - The value of 20 or longer is recommended because the execution time is measured using the timer in 10 ms period.
  - Use **TRACE\_LONG\_RUN\_TIMER** property to increase the precision.
- The following is an example of recording the SQL statement whose cursor life-time is longer than 1 second.

```
gSQL> ALTER SYSTEM SET TRACE_LONG_RUN_CURSOR = 1000;
```

- The following is an example of restoring to the default value.

```
gSQL> ALTER SYSTEM SET TRACE_LONG_RUN_CURSOR TO DEFAULT;
```

It is used to trace the user program maintaining the cursor for a long time as follows.

```
int main()
{
    ...
    EXEC SQL DECLARE cur1 CURSOR FOR SELECT name FROM t1 WHERE pk = :s_id;
    EXEC SQL OPEN cur1
    EXEC SQL FETCH cur1 INTO :s_name;
    ...
    long_run_user_logic( s_name ); ❶ Due to the user logic, user fails to clean up resources
    for a long time.
    ...
    EXEC SQL CLOSE cur1;
    ...
}
```

## 10.245 TRACE\_LONG\_RUN\_SQL

### Basic Information

| Item             | Description                                                                        |
|------------------|------------------------------------------------------------------------------------|
| Name             | TRACE_LONG_RUN_SQL                                                                 |
| Summary          | write trace for long-run SQL over specific execution time (mili-sec. 0 ~ 10000000) |
| Data type        | BIGINT                                                                             |
| Applicable phase | NO MOUNT or above                                                                  |
| Updatable        | TRUE                                                                               |
| ALTER SESSION    | TRUE                                                                               |
| ALTER SYSTEM     | IMMEDIATE                                                                          |
| MIN              | 0                                                                                  |
| MAX              | 10000000                                                                           |
| Default value    | 0                                                                                  |

### Description

It records the SQL statement whose execution time is longer than the specified property time in the trace file (\$GOLDILOCKS\_DATA/trc/system.trc).

- Description of value
  - Unit: millisecond
  - Value 0: It does not record information.
  - Recommended value: 20 (millisecond) or longer
  - The value of 20 or longer is recommended because the execution time is measured using the timer in 10 ms period.
  - Use **TRACE\_LONG\_RUN\_TIMER** property to increase the precision.

The following is an example of recording the SQL statement whose execution time is longer than 1 second.

```
gSQL> ALTER SYSTEM SET TRACE_LONG_RUN_SQL = 1000;
```

The following is an example of restoring to the default value.

```
| gSQL> ALTER SYSTEM SET TRACE_LONG_RUN_SQL TO DEFAULT;
```

## 10.246 TRACE\_LONG\_RUN\_TIMER

### Basic Information

| Item             | Description                                                                            |
|------------------|----------------------------------------------------------------------------------------|
| Name             | TRACE_LONG_RUN_TIMER                                                                   |
| Summary          | trace long-run timer resolution ( 0: timer thread(10 ms interval), 1: gettimeofday() ) |
| Data type        | BOOLEAN                                                                                |
| Applicable phase | NO MOUNT or above                                                                      |
| Updatable        | TRUE                                                                                   |
| ALTER SESSION    | TRUE                                                                                   |
| ALTER SYSTEM     | IMMEDIATE                                                                              |
| MIN              | 0                                                                                      |
| MAX              | 1                                                                                      |
| Default value    | 0                                                                                      |

### Description

It controls the measurement precision when measuring the execution time of the SQL statement by using the following properties.

- **TRACE\_LONG\_RUN\_CURSOR**
- **TRACE\_LONG\_RUN\_SQL**
- Description of value
  - 0: It uses the timer thread whose interval is 10 milliseconds.
  - 1: It measures the time by using gettimeofday() function. In this case, the precision is higher but the system call causes the work load.



## 10.247 TRACE\_XA

### Basic Information

| Item             | Description                         |
|------------------|-------------------------------------|
| Name             | TRACE_XA                            |
| Summary          | logging trace log for xa interfaces |
| Data type        | BOOLEAN                             |
| Applicable phase | NO MOUNT or above                   |
| Updatable        | TRUE                                |
| ALTER SESSION    | FALSE                               |
| ALTER SYSTEM     | IMMEDIATE                           |
| MIN              | 0                                   |
| MAX              | 1                                   |
| Default value    | NO                                  |

### Description

It specifies whether to output trace messages when using XA interface. Message is output to the 'SYSTEM\_LOGGER\_DIR / xa.trc'.

## 10.248 TRANSACTION\_ALLOCATION\_TIMEOUT

### Basic Information

| Item             | Description                                        |
|------------------|----------------------------------------------------|
| Name             | TRANSACTION_ALLOCATION_TIMEOUT                     |
| Summary          | a time limit (sec) for allocating transaction slot |
| Data type        | BIGINT                                             |
| Applicable phase | NO MOUNT or above                                  |
| Updatable        | TRUE                                               |
| ALTER SESSION    | TRUE                                               |
| ALTER SYSTEM     | IMMEDIATE                                          |
| MIN              | 0                                                  |
| MAX              | 100000000                                          |
| Default value    | 3                                                  |

### Description

It is the maximum waiting time when allocating transaction slots.

The following error occurs when the waiting time exceeds TRANSACTION\_ALLOCATION\_TIMEOUT.

```
gSQL> insert into t1 values(1);  
ERR-HYT00(14129): transaction allocation time exceeded
```

## 10.249 TRANSACTION\_COMMIT\_WRITE\_MODE

### Basic Information

| Item             | Description                                         |
|------------------|-----------------------------------------------------|
| Name             | TRANSACTION_COMMIT_WRITE_MODE                       |
| Summary          | transaction commit write mode (0: no_wait, 1: wait) |
| Data type        | BIGINT                                              |
| Applicable phase | NO MOUNT or above                                   |
| Updatable        | TRUE                                                |
| ALTER SESSION    | TRUE                                                |
| ALTER SYSTEM     | IMMEDIATE                                           |
| MIN              | 0                                                   |
| MAX              | 1                                                   |
| Default value    | 0                                                   |

### Description

TRANSACTION\_COMMIT\_WRITE\_MODE specifies whether a log generated by the transaction is flushed to the disk log file, when the transaction is committed. If TRANSACTION\_COMMIT\_WRITE\_MODE is '1', the log should be flushed to the disk log file at the time of the transaction commit. Otherwise the transaction is committed regardless of log flush.

If the system is operated when TRANSACTION\_COMMIT\_WRITE\_MODE is set to '0', the latest data will be lost when GOLDILOCKS is abnormally terminated without log flush after COMMIT transaction. It is because the logs are not recorded in this case.

Therefore, if all committed transactions should be remained (stored) in database, the system should be operated after setting TRANSACTION\_COMMIT\_WRITE\_MODE to '1'. Or, 'ALTER SYSTEM FLUSH LOGS' statement should be explicitly performed at the time of transaction commit in order to flush log after TRANSACTION\_COMMIT\_WRITE\_MODE is set to '0'.

- 0: no wait
- 1: wait

# 10.250 TRANSACTION\_MAXIMUM\_UNDO\_PAGE\_COUNT

## Basic Information

| Item             | Description                                                    |
|------------------|----------------------------------------------------------------|
| Name             | TRANSACTION_MAXIMUM_UNDO_PAGE_COUNT                            |
| Summary          | The maximum number of undo pages that a transaction can write. |
| Data type        | BIGINT                                                         |
| Applicable phase | NO MOUNT or below                                              |
| Updatable        | TRUE                                                           |
| ALTER SESSION    | TRUE                                                           |
| ALTER SYSTEM     | IMMEDIATE                                                      |
| MIN              | 1                                                              |
| MAX              | 13107200                                                       |
| Default value    | 13107200                                                       |

## Description

It means the maximum number of undo pages which the transaction can record. The minimum value is 1 (8 Kbytes) and the maximum value is 13107200 (100 Gbytes).

## 10.251 TRANSACTION\_TABLE\_SIZE

### Basic Information

| Item             | Description            |
|------------------|------------------------|
| Name             | TRANSACTION_TABLE_SIZE |
| Summary          | transaction table size |
| Data type        | BIGINT                 |
| Applicable phase | NO MOUNT or below      |
| Updatable        | TRUE                   |
| ALTER SESSION    | FALSE                  |
| ALTER SYSTEM     | IMMEDIATE              |
| MIN              | 64                     |
| MAX              | 10240                  |
| Default value    | 1024                   |

### Description

It sets the maximum number of transaction table which is executed in database. The transaction table is allocated to ensure ACID of transaction when updating database. The database should restart to modify the number of transaction tables, and the number can be modified only to the number bigger than the previously specified number.

If it is modified to a smaller number, then the restart fails. For example, if the value set as 1,024 is modified to 512, then the restart fails as follows. In this case, modify it to 1,024 or bigger, then the restart succeeds.

```
gSQL> ALTER SYSTEM SET TRANSACTION_TABLE_SIZE = 512 SCOPE = FILE;
```

```
System altered.
```

```
gSQL> \CONNECT sys gliese as sysdba
```

```
gSQL> \SHUTDOWN
```

```
Shutdown success
```

- The restart fails.

```
gSQL> \STARTUP
```

```
ERR-HY000(14118): TRANSACTION_TABLE_SIZE property value must be equal to or greater than
```

'1024'

```
gSQL> ALTER SYSTEM SET TRANSACTION_TABLE_SIZE = 1024 SCOPE = FILE;
```

System altered.

```
gSQL> \SHUTDOWN
```

Shutdown success

```
gSQL> \STARTUP
```

Startup success

## 10.252 TRANSACTION\_TIMEOUT

### Basic Information

| Item             | Description             |
|------------------|-------------------------|
| Name             | TRANSACTION_TIMEOUT     |
| Summary          | transaction timeout (s) |
| Data type        | BIGINT                  |
| Applicable phase | NO MOUNT or above       |
| Updatable        | TRUE                    |
| ALTER SESSION    | FALSE                   |
| ALTER SYSTEM     | IMMEDIATE               |
| MIN              | 0                       |
| MAX              | 10000000                |
| Default value    | 0                       |

### Description

It sets the duration of when the transaction is activated. It is used to prevent the side effects of when the transaction is activated for a long time. If a transaction exceeds the specified time, then gmaster daemon automatically terminates the session owned by that transaction.

## 10.253 UNDO\_RELATION\_ALLOCATION\_TIMEOUT

### Basic Information

| Item             | Description                                     |
|------------------|-------------------------------------------------|
| Name             | UNDO_RELATION_ALLOCATION_TIMEOUT                |
| Summary          | a time limit (sec) for allocating undo relation |
| Data type        | BIGINT                                          |
| Applicable phase | NO MOUNT or above                               |
| Updatable        | TRUE                                            |
| ALTER SESSION    | TRUE                                            |
| ALTER SYSTEM     | IMMEDIATE                                       |
| MIN              | 0                                               |
| MAX              | 100000000                                       |
| Default value    | 3                                               |

### Description

It is the maximum waiting time when allocating undo relations.

The following error occurs when the waiting time exceeds UNDO\_RELATION\_ALLOCATION\_TIMEOUT.

```
gSQL> insert into t1 values(1);  
ERR-HYT00(14130): undo relation allocation time exceeded
```



## 10.254 UNDO\_RELATION\_COUNT

### Basic Information

| Item             | Description         |
|------------------|---------------------|
| Name             | UNDO_RELATION_COUNT |
| Summary          | undo relation count |
| Data type        | BIGINT              |
| Applicable phase | NO MOUNT or below   |
| Updatable        | TRUE                |
| ALTER SESSION    | FALSE               |
| ALTER SYSTEM     | IMMEDIATE           |
| MIN              | 8                   |
| MAX              | 10240               |
| Default value    | 128                 |

### Description

It sets the number of undo relation to be used in database. Undo relation is allocated for the purpose that the transaction executing DML uses undo segment. The database should restart to modify the number of undo relations, and the number can be modified only to the number bigger than the previously specified number.

If it is modified to a smaller number, then the restart fails. For example, if the value set as 128 is modified to 64, then the restart fails as follows. In this case, modify it to 128 or bigger, then the restart succeeds.

```
gSQL> ALTER SYSTEM SET UNDO_RELATION_COUNT = 64 SCOPE = FILE;
```

```
System altered.
```

```
gSQL> \CONNECT sys gliese as sysdba
```

```
gSQL> \SHUTDOWN
```

```
Shutdown success
```

- The restart fails.

```
gSQL> \STARTUP
```

```
ERR-HY000(14119): UNDO_RELATION_COUNT property value must be equal to or greater than '128'
```

```
gSQL> ALTER SYSTEM SET UNDO_RELATION_COUNT = 128 SCOPE = FILE;
```

```
System altered.  
gSQL> \SHUTDOWN  
Shutdown success  
gSQL> \STARTUP  
Startup success
```

## 10.255 UNDO\_SHRINK\_THRESHOLD

### Basic Information

| Item             | Description                                              |
|------------------|----------------------------------------------------------|
| Name             | UNDO_SHRINK_THRESHOLD                                    |
| Summary          | threshold bytes to attempt to shrink undo segment (byte) |
| Data type        | BIGINT                                                   |
| Applicable phase | NO MOUNT or above                                        |
| Updatable        | TRUE                                                     |
| ALTER SESSION    | FALSE                                                    |
| ALTER SYSTEM     | IMMEDIATE                                                |
| MIN              | 1048576                                                  |
| MAX              | 107374182400                                             |
| Default value    | 10485760                                                 |

### Description

Ager thread periodically (10 seconds) checks the undo segment space. If it occupies more space than this property value, then the reusable space is returned to the tablespace. The attempt to return is made until the undo segment space remains as big as this property (byte), and the return is finished when the amount of the remaining undo page becomes smaller than MINIMUM\_UNDO\_PAGE\_COUNT.

# 10.256 USE\_LARGE\_PAGES

## Basic Information

| Item             | Description       |
|------------------|-------------------|
| Name             | USE_LARGE_PAGES   |
| Summary          | use large pages   |
| Data type        | BIGINT            |
| Applicable phase | NO MOUNT or above |
| Updatable        | TRUE              |
| ALTER SESSION    | FALSE             |
| ALTER SYSTEM     | IMMEDIATE         |
| MIN              | 0                 |
| MAX              | 2                 |
| Default value    | 0                 |

## Description

It uses HugePage. HugePage should first be set in the device to use USE\_LARGE\_PAGES property.

- 0: It does not use the large page.
- 1: It uses the large page. When it fails to allocate the shared memory, then an error occurs.
- 2: It tries to allocate the shared memory by using the large page. When it fails to allocate the shared memory, then it allocates the memory by using the regular page.



It can be used in Linux kernel 2.6.32-573 or higher.

## 10.257 USER\_DATA\_TABLESPACE\_MEDIA\_TYPE

### Basic Information

| Item             | Description                                |
|------------------|--------------------------------------------|
| Name             | USER_DATA_TABLESPACE_MEDIA_TYPE            |
| Summary          | default media type of user data tablespace |
| Data type        | BIGINT                                     |
| Applicable phase | NO MOUNT or above                          |
| Updatable        | TRUE                                       |
| ALTER SESSION    | TRUE                                       |
| ALTER SYSTEM     | IMMEDIATE                                  |
| MIN              | 0 ( Memory )                               |
| MAX              | 1 ( Disk )                                 |
| Default value    | 0 ( Memory )                               |

### Description

It sets the default media type if the media type of the tablespace is omitted when creating the user data tablespace. 0 is memory and 1 is the disk.

## 10.258 USER\_DATA\_TABLESPACE\_SIZE

### Basic Information

| Item             | Description                             |
|------------------|-----------------------------------------|
| Name             | USER_DATA_TABLESPACE_SIZE               |
| Summary          | default user data tablespace size(byte) |
| Data type        | BIGINT                                  |
| Applicable phase | NO MOUNT or above                       |
| Updatable        | TRUE                                    |
| ALTER SESSION    | TRUE                                    |
| ALTER SYSTEM     | IMMEDIATE                               |
| MIN              | 32 Mega                                 |
| MAX              | 30 Giga                                 |
| Default value    | 32 Mega                                 |

### Description

It sets the default size if the data file size is omitted when creating the user data tablespace or adding the data file.

# 10.259 USER\_DISK\_DATA\_TABLESPACE\_NEXTSIZE

## Basic Information

| Item             | Description                               |
|------------------|-------------------------------------------|
| Name             | USER_DISK_DATA_TABLESPACE_NEXTSIZE        |
| Summary          | default next size of user data tablespace |
| Data type        | BIGINT                                    |
| Applicable phase | NO MOUNT or above                         |
| Updatable        | TRUE                                      |
| ALTER SESSION    | TRUE                                      |
| ALTER SYSTEM     | IMMEDIATE                                 |
| MIN              | 3554432 Byte                              |
| MAX              | 30 Giga                                   |
| Default value    | 10 Mega                                   |

## Description

It sets the default size if the size to be extended is not set when it is required to extend the data file of the user disk data tablespace.

## 10.260 USER\_TEMP\_TABLESPACE\_SIZE

### Basic Information

| Item             | Description                             |
|------------------|-----------------------------------------|
| Name             | USER_TEMP_TABLESPACE_SIZE               |
| Summary          | default user temp tablespace size(byte) |
| Data type        | BIGINT                                  |
| Applicable phase | NO MOUNT or above                       |
| Updatable        | TRUE                                    |
| ALTER SESSION    | TRUE                                    |
| ALTER SYSTEM     | IMMEDIATE                               |
| MIN              | 32 Mega                                 |
| MAX              | 30 Giga                                 |
| Default value    | 32 Mega                                 |

### Description

It sets the default size if the data file size is omitted when creating the user temp tablespace or adding the data file.



## 10.261 XA\_TRANSACTION\_IDLE\_TIMEOUT

### Basic Information

| Item             | Description                     |
|------------------|---------------------------------|
| Name             | XA_TRANSACTION_IDLE_TIMEOUT     |
| Summary          | idle timeout for xa transaction |
| Data type        | BIGINT                          |
| Applicable phase | NO MOUNT or above               |
| Updatable        | TRUE                            |
| ALTER SESSION    | FALSE                           |
| ALTER SYSTEM     | IMMEDIATE                       |
| MIN              | 0 ( no limit )                  |
| MAX              | 10000000                        |
| Default value    | 60                              |

### Description

It is the maximum waiting time of xa transaction in idle (The duration between the beginning of XA and the next transaction). If it remains in Idle exceeding this time, then xa transaction is rolled back.

If it is set to 0, then XA infinitely waits even in idle.



## Part III.

---

# SQL Manual

|                                   |              |
|-----------------------------------|--------------|
| <b>11. SQL Elements</b>           | <b>1,069</b> |
| 11.1 Syntax Elements              | 1,070        |
| Identifiers                       | 1,070        |
| Literals                          | 1,070        |
| Null Value                        | 1,084        |
| Comments                          | 1,084        |
| SQL Reserved Words and Keywords   | 1,085        |
| Compatibility for Syntax Elements | 1,090        |
| 11.2 Data Type                    | 1,092        |
| Numeric Type                      | 1,092        |
| CHARACTER STRING Type             | 1,094        |
| BINARY STRING Type                | 1,094        |
| Date/ Time Type                   | 1,095        |
| INTERVAL Type                     | 1,095        |
| BOOLEAN Type                      | 1,095        |
| ROWID Type                        | 1,096        |
| Type Comparison                   | 1,096        |
| Type Conversion                   | 1,103        |
| Type Combination                  | 1,110        |
| Compatibility for Data Type       | 1,115        |
| 11.3 Format String                | 1,118        |
| Number Format String              | 1,118        |
| Datetime Format String            | 1,121        |
| 11.4 Expressions                  | 1,132        |
| Boolean Value Expression          | 1,132        |
| CASE Expression                   | 1,134        |
| CAST Specification                | 1,136        |
| Scalar Subquery Expression        | 1,137        |
| Compatibility                     | 1,137        |
| 11.5 Pseudo Columns               | 1,139        |
| ROWID Pseudo Column               | 1,139        |
| CLUSTER_GROUP_ID Pseudo Column    | 1,140        |
| CLUSTER_MEMBER_ID Pseudo Column   | 1,141        |
| CLUSTER_GROUP_NAME Pseudo Column  | 1,141        |
| CLUSTER_MEMBER_NAME Pseudo Column | 1,142        |
| CLUSTER_SHARD_ID Pseudo Column    | 1,142        |
| Compatibility                     | 1,143        |
| 11.6 Operators                    | 1,144        |
| Arithmetic Operator               | 1,144        |

|                                 |              |
|---------------------------------|--------------|
| Concatenation Operator          | 1,145        |
| Set Operator                    | 1,145        |
| Compatibility                   | 1,146        |
| 11.7 Functions                  | 1,147        |
| Single Row Function             | 1,147        |
| Aggregate Function              | 1,153        |
| Compatibility                   | 1,153        |
| 11.8 Conditions                 | 1,155        |
| Condition                       | 1,155        |
| Comparison Conditions           | 1,155        |
| Logical Conditions              | 1,159        |
| Null Condition                  | 1,160        |
| Compound Conditions             | 1,161        |
| Pattern-matching Conditions     | 1,161        |
| BETWEEN Condition               | 1,162        |
| IN Condition                    | 1,163        |
| EXISTS Condition                | 1,164        |
| Compatibility                   | 1,165        |
| <b>12. SQL Languages</b>        | <b>1,167</b> |
| 12.1 Data Definition Language   | 1,168        |
| DDL Related Statements          | 1,168        |
| Concepts of DDL                 | 1,168        |
| DDL and Transaction             | 1,169        |
| 12.2 Data Manipulation Language | 1,178        |
| DML Related Statements          | 1,178        |
| Concepts of DML                 | 1,178        |
| Inserting Data                  | 1,179        |
| Deleting Data                   | 1,181        |
| Updating Data                   | 1,181        |
| Manipulating Data Using Cursor  | 1,182        |
| DML Query                       | 1,183        |
| 12.3 Data Query Language        | 1,186        |
| Query Related Statements        | 1,186        |
| Concepts of Query               | 1,186        |
| Basic Query                     | 1,187        |
| SET Operator                    | 1,189        |
| Common Table Expression (CTE)   | 1,190        |
| Join                            | 1,195        |
| Hierarchical Query              | 1,200        |

|                                     |              |
|-------------------------------------|--------------|
| Grouping Result Set (group by)      | 1,205        |
| Sorting Result Set (order by)       | 1,206        |
| Subquery                            | 1,207        |
| 12.4 Control Language               | 1,209        |
| Control Language Related Statements | 1,209        |
| Transaction Control                 | 1,209        |
| Session Control                     | 1,212        |
| System Control                      | 1,213        |
| 12.5 Processing SQL in Cluster      | 1,214        |
| Processing DDL in Cluster           | 1,214        |
| Processing SELECT in Cluster        | 1,215        |
| Processing DML in Cluster           | 1,310        |
| <b>13. SQL Objects</b>              | <b>1,331</b> |
| 13.1 Database                       | 1,332        |
| Database-related Statements         | 1,332        |
| Database Configuration Objects      | 1,333        |
| Built-in Objects                    | 1,336        |
| 13.2 Profile                        | 1,339        |
| Profile-related Statements          | 1,339        |
| Concepts of Profile                 | 1,339        |
| 13.3 Audit Policy                   | 1,345        |
| Audit Policy-related Statement      | 1,345        |
| Examples                            | 1,345        |
| Concepts of Audit Policy            | 1,349        |
| 13.4 Authorization                  | 1,373        |
| Authorization-related Statements    | 1,373        |
| Concepts of User                    | 1,374        |
| Creating Objects and Privileges     | 1,375        |
| Privileges                          | 1,378        |
| 13.5 Schema                         | 1,384        |
| Schema-related Statements           | 1,384        |
| Concepts of Schema                  | 1,384        |
| User and Schema                     | 1,385        |
| Schema Path                         | 1,387        |
| PUBLIC Schema                       | 1,390        |
| Examples of Using User and Schema   | 1,392        |
| 13.6 Tablespace                     | 1,395        |
| Tablespace-related Statements       | 1,395        |
| Concepts of Tablespace              | 1,395        |

|                                     |              |
|-------------------------------------|--------------|
| 13.7 Table                          | 1,398        |
| Table-related Statements            | 1,398        |
| Concepts of Table                   | 1,399        |
| Global Temporary Table              | 1,402        |
| Table in Cluster                    | 1,403        |
| Managing Recycle Bin of Table       | 1,403        |
| 13.8 Index                          | 1,408        |
| Index-related Statements            | 1,408        |
| Concepts of Index                   | 1,408        |
| Concepts of UNIQUE                  | 1,410        |
| 13.9 View                           | 1,412        |
| View-related Statements             | 1,412        |
| Concepts of View                    | 1,412        |
| 13.10 Sequence                      | 1,415        |
| Sequence-related Statements         | 1,415        |
| Concepts of Sequence                | 1,415        |
| Cluster Sequence                    | 1,418        |
| 13.11 Synonym                       | 1,419        |
| Synonym-related Statements          | 1,419        |
| Concepts of Synonym                 | 1,419        |
| 13.12 Stored Procedure              | 1,422        |
| Stored Procedure-related Statements | 1,422        |
| Concepts of Stored Procedure        | 1,422        |
| 13.13 Stored Function               | 1,424        |
| Stored Function-related Statements  | 1,424        |
| Concepts of Stored Function         | 1,424        |
| 13.14 Package                       | 1,426        |
| Package-related Statement           | 1,426        |
| Concepts of Package                 | 1,427        |
| <b>14. Cluster Objects</b>          | <b>1,429</b> |
| 14.1 Cluster System                 | 1,430        |
| Cluster System Related Statements   | 1,430        |
| Concepts of Cluster System          | 1,430        |
| Availability of Cluster System      | 1,433        |
| Expanding Cluster System            | 1,434        |
| 14.2 Cluster Group                  | 1,437        |
| Cluster Group Related Statements    | 1,437        |
| Concepts of Cluster Group           | 1,437        |
| 14.3 Cluster Member                 | 1,439        |

|                                                |              |
|------------------------------------------------|--------------|
| Cluster Member Related Statements              | 1,439        |
| Concepts of Cluster Member                     | 1,439        |
| 14.4 Cluster Location                          | 1,441        |
| Cluster Location Related Statements            | 1,441        |
| Concepts of Cluster Location                   | 1,441        |
| 14.5 Cluster Table and Shard                   | 1,442        |
| Shard Related Statements                       | 1,442        |
| Cluster Table Type                             | 1,442        |
| Cloned Table                                   | 1,443        |
| Hash-sharded table                             | 1,447        |
| Range-sharded Table                            | 1,449        |
| List-sharded Table                             | 1,451        |
| Rebalancing Cluster Table                      | 1,454        |
| 14.6 Global Secondary Index                    | 1,461        |
| Global Secondary Index Related Statements      | 1,461        |
| Concepts of Global Secondary Index             | 1,461        |
| <b>15. SQL Tuning</b>                          | <b>1,463</b> |
| 15.1 SQL Tuning                                | 1,464        |
| Overview                                       | 1,464        |
| SQL Processing                                 | 1,464        |
| 15.2 Rewriter                                  | 1,472        |
| Filter Push Down                               | 1,472        |
| DISTINCT Elimination                           | 1,473        |
| ORDER BY Elimination                           | 1,474        |
| Simple View Merging                            | 1,475        |
| Outer Join Table Elimination                   | 1,478        |
| Outer Join Operation Elimination               | 1,479        |
| EXISTS/NOT EXIST Operation Target Optimization | 1,480        |
| Quantifier Elimination                         | 1,482        |
| Transitive Closure                             | 1,484        |
| Join Transitive Closure                        | 1,484        |
| Subquery Unnesting                             | 1,486        |
| Complex View Merging                           | 1,489        |
| 15.3 Enumerator                                | 1,492        |
| Access Paths                                   | 1,492        |
| Join                                           | 1,498        |
| Group By                                       | 1,518        |
| Distinct                                       | 1,521        |
| Single Row Aggregation                         | 1,522        |



|                                                |              |
|------------------------------------------------|--------------|
| Order By .....                                 | 1,524        |
| 15.4 Cluster .....                             | 1,527        |
| Table Sharding Strategy .....                  | 1,527        |
| Access .....                                   | 1,530        |
| Join .....                                     | 1,537        |
| Group By .....                                 | 1,550        |
| Distinct .....                                 | 1,552        |
| Order By .....                                 | 1,555        |
| Aggregation .....                              | 1,558        |
| 15.5 Statistics Information .....              | 1,562        |
| Adjusting Optimizer .....                      | 1,562        |
| 15.6 SQL Hint .....                            | 1,563        |
| Description .....                              | 1,563        |
| Syntax .....                                   | 1,563        |
| Statement Hint .....                           | 1,569        |
| Query Block Hint .....                         | 1,571        |
| Operation Hint .....                           | 1,661        |
| 15.7 SQL Trace Log .....                       | 1,735        |
| Overview .....                                 | 1,735        |
| Output .....                                   | 1,735        |
| Output Format .....                            | 1,736        |
| Examples .....                                 | 1,738        |
| <b>16. Built-in Data Type References .....</b> | <b>1,741</b> |
| 16.1 Aliases of Built-in Data Types .....      | 1,742        |
| 16.2 BINARY .....                              | 1,745        |
| Syntax .....                                   | 1,745        |
| Syntax Rules and Parameters .....              | 1,745        |
| Description .....                              | 1,745        |
| For More Information .....                     | 1,745        |
| 16.3 BINARY VARYING .....                      | 1,746        |
| Syntax .....                                   | 1,746        |
| Syntax Rules and Parameters .....              | 1,746        |
| Description .....                              | 1,746        |
| For More Information .....                     | 1,746        |
| 16.4 BINARY LONG VARYING .....                 | 1,747        |
| Syntax .....                                   | 1,747        |
| Description .....                              | 1,747        |
| For More Information .....                     | 1,747        |
| 16.5 BOOLEAN .....                             | 1,748        |

|                                   |       |
|-----------------------------------|-------|
| Syntax .....                      | 1,748 |
| Description .....                 | 1,748 |
| 16.6 CHARACTER .....              | 1,749 |
| Syntax .....                      | 1,749 |
| Syntax Rules and Parameters ..... | 1,749 |
| Description .....                 | 1,749 |
| For More Information .....        | 1,750 |
| 16.7 CHARACTER VARYING .....      | 1,751 |
| Syntax .....                      | 1,751 |
| Syntax Rules and Parameters ..... | 1,751 |
| Description .....                 | 1,751 |
| For More Information .....        | 1,751 |
| 16.8 CHARACTER LONG VARYING ..... | 1,752 |
| Syntax .....                      | 1,752 |
| Description .....                 | 1,752 |
| For More Information .....        | 1,752 |
| 16.9 DATE .....                   | 1,753 |
| Syntax .....                      | 1,753 |
| Description .....                 | 1,753 |
| For More Information .....        | 1,753 |
| 16.10 FLOAT .....                 | 1,754 |
| Syntax .....                      | 1,754 |
| Syntax Rules and Parameters ..... | 1,754 |
| Description .....                 | 1,754 |
| For More Information .....        | 1,754 |
| 16.11 INTERVAL .....              | 1,755 |
| Syntax .....                      | 1,755 |
| Syntax Rules and Parameters ..... | 1,755 |
| Description .....                 | 1,758 |
| For More Information .....        | 1,758 |
| 16.12 NATIVE_BIGINT .....         | 1,759 |
| Syntax .....                      | 1,759 |
| Description .....                 | 1,759 |
| 16.13 NATIVE_DOUBLE .....         | 1,760 |
| Syntax .....                      | 1,760 |
| Description .....                 | 1,760 |
| 16.14 NATIVE_INTEGER .....        | 1,761 |
| Syntax .....                      | 1,761 |
| Description .....                 | 1,761 |

|            |                                     |              |
|------------|-------------------------------------|--------------|
| 16.15      | NATIVE_REAL                         | 1,762        |
|            | Syntax                              | 1,762        |
|            | Description                         | 1,762        |
| 16.16      | NATIVE_SMALLINT                     | 1,763        |
|            | Syntax                              | 1,763        |
|            | Description                         | 1,763        |
| 16.17      | NUMBER                              | 1,764        |
|            | Syntax                              | 1,764        |
|            | Syntax Rules and Parameters         | 1,764        |
|            | Description                         | 1,764        |
|            | For More Information                | 1,765        |
| 16.18      | NUMERIC                             | 1,766        |
|            | Syntax                              | 1,766        |
|            | Syntax Rules and Parameters         | 1,766        |
|            | Description                         | 1,766        |
|            | For More Information                | 1,767        |
| 16.19      | ROWID                               | 1,768        |
|            | Syntax                              | 1,768        |
|            | Description                         | 1,768        |
|            | For More Information                | 1,768        |
| 16.20      | TIME                                | 1,769        |
|            | Syntax                              | 1,769        |
|            | Syntax Rules and Parameters         | 1,769        |
|            | Description                         | 1,769        |
|            | For More Information                | 1,769        |
| 16.21      | TIMESTAMP                           | 1,770        |
|            | Syntax                              | 1,770        |
|            | Syntax Rules and Parameters         | 1,770        |
|            | Description                         | 1,770        |
|            | For More Information                | 1,770        |
| <b>17.</b> | <b>Built-in Function References</b> | <b>1,771</b> |
| 17.1       | * (MULTIPLICATION)                  | 1,772        |
|            | Syntax                              | 1,772        |
|            | Description                         | 1,772        |
|            | Example                             | 1,773        |
| 17.2       | + (ADDITION)                        | 1,774        |
|            | Syntax                              | 1,774        |
|            | Description                         | 1,774        |
|            | Example                             | 1,775        |

|                       |       |
|-----------------------|-------|
| 17.3 + (POSITIVE)     | 1,776 |
| Syntax                | 1,776 |
| Description           | 1,776 |
| Example               | 1,776 |
| 17.4 - (NEGATIVE)     | 1,777 |
| Syntax                | 1,777 |
| Description           | 1,777 |
| Example               | 1,777 |
| 17.5 - (SUBTRACTION)  | 1,778 |
| Syntax                | 1,778 |
| Description           | 1,778 |
| Example               | 1,779 |
| 17.6 / (DIVISION)     | 1,781 |
| Syntax                | 1,781 |
| Description           | 1,781 |
| Example               | 1,781 |
| 17.7    (CONCATENATE) | 1,783 |
| Syntax                | 1,783 |
| Description           | 1,783 |
| Example               | 1,783 |
| 17.8 ABS              | 1,785 |
| Syntax                | 1,785 |
| Description           | 1,785 |
| Example               | 1,785 |
| 17.9 ACOS             | 1,786 |
| Syntax                | 1,786 |
| Description           | 1,786 |
| Example               | 1,786 |
| 17.10 ADDDATE         | 1,787 |
| Syntax                | 1,787 |
| Description           | 1,787 |
| Example               | 1,787 |
| 17.11 ADDTIME         | 1,788 |
| Syntax                | 1,788 |
| Description           | 1,788 |
| Example               | 1,788 |
| 17.12 ADD_MONTHS      | 1,789 |
| Syntax                | 1,789 |
| Description           | 1,789 |

|                        |       |
|------------------------|-------|
| Example .....          | 1,789 |
| 17.13 ASCII .....      | 1,790 |
| Syntax .....           | 1,790 |
| Description .....      | 1,790 |
| Example .....          | 1,790 |
| 17.14 ASIN .....       | 1,791 |
| Syntax .....           | 1,791 |
| Description .....      | 1,791 |
| Example .....          | 1,791 |
| 17.15 ATAN .....       | 1,792 |
| Syntax .....           | 1,792 |
| Description .....      | 1,792 |
| Example .....          | 1,792 |
| 17.16 ATAN2 .....      | 1,793 |
| Syntax .....           | 1,793 |
| Description .....      | 1,793 |
| Example .....          | 1,793 |
| 17.17 AVG .....        | 1,794 |
| Syntax .....           | 1,794 |
| Description .....      | 1,794 |
| Example .....          | 1,794 |
| 17.18 BITAND .....     | 1,795 |
| Syntax .....           | 1,795 |
| Description .....      | 1,795 |
| Example .....          | 1,795 |
| 17.19 BITNOT .....     | 1,796 |
| Syntax .....           | 1,796 |
| Description .....      | 1,796 |
| Example .....          | 1,796 |
| 17.20 BITOR .....      | 1,797 |
| Syntax .....           | 1,797 |
| Description .....      | 1,797 |
| Example .....          | 1,797 |
| 17.21 BITXOR .....     | 1,798 |
| Syntax .....           | 1,798 |
| Description .....      | 1,798 |
| Example .....          | 1,798 |
| 17.22 BIT_LENGTH ..... | 1,799 |
| Syntax .....           | 1,799 |

|                                  |       |
|----------------------------------|-------|
| Description .....                | 1,799 |
| Example .....                    | 1,799 |
| 17.23 BYTE_LENGTH .....          | 1,800 |
| Syntax .....                     | 1,800 |
| Description .....                | 1,800 |
| Example .....                    | 1,800 |
| 17.24 CASE2 .....                | 1,801 |
| Syntax .....                     | 1,801 |
| Description .....                | 1,801 |
| Example .....                    | 1,802 |
| 17.25 CBRT .....                 | 1,803 |
| Syntax .....                     | 1,803 |
| Description .....                | 1,803 |
| Example .....                    | 1,803 |
| 17.26 CEIL .....                 | 1,804 |
| Syntax .....                     | 1,804 |
| Description .....                | 1,804 |
| Example .....                    | 1,804 |
| 17.27 CHAR_LENGTH .....          | 1,805 |
| Syntax .....                     | 1,805 |
| Description .....                | 1,805 |
| Example .....                    | 1,805 |
| 17.28 CHR .....                  | 1,806 |
| Syntax .....                     | 1,806 |
| Description .....                | 1,806 |
| Example .....                    | 1,806 |
| 17.29 CLOCK_DATE .....           | 1,807 |
| Syntax .....                     | 1,807 |
| Description .....                | 1,807 |
| Example .....                    | 1,807 |
| 17.30 CLOCK_LOCALTIME .....      | 1,808 |
| Syntax .....                     | 1,808 |
| Description .....                | 1,808 |
| Example .....                    | 1,808 |
| 17.31 CLOCK_LOCALTIMESTAMP ..... | 1,809 |
| Syntax .....                     | 1,809 |
| Description .....                | 1,809 |
| Example .....                    | 1,809 |
| 17.32 CLOCK_TIME .....           | 1,810 |

|                             |       |
|-----------------------------|-------|
| Syntax .....                | 1,810 |
| Description .....           | 1,810 |
| Example .....               | 1,810 |
| 17.33 CLOCK_TIMESTAMP ..... | 1,811 |
| Syntax .....                | 1,811 |
| Description .....           | 1,811 |
| Example .....               | 1,811 |
| 17.34 COALESCE .....        | 1,812 |
| Syntax .....                | 1,812 |
| Description .....           | 1,812 |
| Example .....               | 1,812 |
| 17.35 CONCAT .....          | 1,814 |
| Syntax .....                | 1,814 |
| Description .....           | 1,814 |
| Example .....               | 1,814 |
| 17.36 CONCATENATE .....     | 1,815 |
| Syntax .....                | 1,815 |
| Description .....           | 1,815 |
| Example .....               | 1,815 |
| 17.37 COS .....             | 1,816 |
| Syntax .....                | 1,816 |
| Description .....           | 1,816 |
| Example .....               | 1,816 |
| 17.38 COT .....             | 1,817 |
| Syntax .....                | 1,817 |
| Description .....           | 1,817 |
| Example .....               | 1,817 |
| 17.39 COUNT .....           | 1,818 |
| Syntax .....                | 1,818 |
| Description .....           | 1,818 |
| Example .....               | 1,818 |
| 17.40 COUNT(*) .....        | 1,819 |
| Syntax .....                | 1,819 |
| Description .....           | 1,819 |
| Example .....               | 1,819 |
| 17.41 CURRENT_CATALOG ..... | 1,820 |
| Syntax .....                | 1,820 |
| Description .....           | 1,820 |
| Example .....               | 1,820 |

|       |                   |       |
|-------|-------------------|-------|
| 17.42 | CURRENT_DATE      | 1,821 |
|       | Syntax            | 1,821 |
|       | Description       | 1,821 |
|       | Example           | 1,821 |
| 17.43 | CURRENT_SCHEMA    | 1,822 |
|       | Syntax            | 1,822 |
|       | Description       | 1,822 |
|       | Example           | 1,822 |
| 17.44 | CURRENT_TIME      | 1,823 |
|       | Syntax            | 1,823 |
|       | Description       | 1,823 |
|       | Example           | 1,823 |
| 17.45 | CURRENT_TIMESTAMP | 1,824 |
|       | Syntax            | 1,824 |
|       | Description       | 1,824 |
|       | Example           | 1,824 |
| 17.46 | CURRENT_USER      | 1,825 |
|       | Syntax            | 1,825 |
|       | Description       | 1,825 |
|       | Example           | 1,825 |
| 17.47 | CURRVAL           | 1,826 |
|       | Syntax            | 1,826 |
|       | Description       | 1,826 |
|       | Example           | 1,826 |
| 17.48 | DATEADD           | 1,827 |
|       | Syntax            | 1,827 |
|       | Description       | 1,827 |
|       | Example           | 1,828 |
| 17.49 | DATEDIFF          | 1,829 |
|       | Syntax            | 1,829 |
|       | Description       | 1,829 |
|       | Example           | 1,829 |
| 17.50 | DATE_ADD          | 1,831 |
|       | Syntax            | 1,831 |
|       | Description       | 1,831 |
|       | Example           | 1,831 |
| 17.51 | DATE_PART         | 1,832 |
|       | Syntax            | 1,832 |
|       | Description       | 1,832 |



|                         |       |
|-------------------------|-------|
| Example .....           | 1,832 |
| 17.52 DECODE .....      | 1,834 |
| Syntax .....            | 1,834 |
| Description .....       | 1,834 |
| Example .....           | 1,835 |
| 17.53 DEGREES .....     | 1,836 |
| Syntax .....            | 1,836 |
| Description .....       | 1,836 |
| Example .....           | 1,836 |
| 17.54 DIGEST .....      | 1,837 |
| Syntax .....            | 1,837 |
| Description .....       | 1,837 |
| Example .....           | 1,837 |
| 17.55 DUMP .....        | 1,838 |
| Syntax .....            | 1,838 |
| Description .....       | 1,838 |
| Example .....           | 1,838 |
| 17.56 EXP .....         | 1,839 |
| Syntax .....            | 1,839 |
| Description .....       | 1,839 |
| Example .....           | 1,839 |
| 17.57 EXTRACT .....     | 1,840 |
| Syntax .....            | 1,840 |
| Description .....       | 1,840 |
| Example .....           | 1,840 |
| 17.58 FACTORIAL .....   | 1,842 |
| Syntax .....            | 1,842 |
| Description .....       | 1,842 |
| Example .....           | 1,842 |
| 17.59 FLOOR .....       | 1,843 |
| Syntax .....            | 1,843 |
| Description .....       | 1,843 |
| Example .....           | 1,843 |
| 17.60 FROM_BASE64 ..... | 1,844 |
| Syntax .....            | 1,844 |
| Description .....       | 1,844 |
| Example .....           | 1,844 |
| 17.61 FROM_TZ .....     | 1,845 |
| Syntax .....            | 1,845 |

|                                 |       |
|---------------------------------|-------|
| Description .....               | 1,845 |
| Example .....                   | 1,845 |
| 17.62 GREATEST .....            | 1,846 |
| Syntax .....                    | 1,846 |
| Description .....               | 1,846 |
| Example .....                   | 1,846 |
| 17.63 HEX .....                 | 1,847 |
| Syntax .....                    | 1,847 |
| Description .....               | 1,847 |
| Example .....                   | 1,847 |
| 17.64 INITCAP .....             | 1,848 |
| Syntax .....                    | 1,848 |
| Description .....               | 1,848 |
| Example .....                   | 1,848 |
| 17.65 INSTR .....               | 1,849 |
| Syntax .....                    | 1,849 |
| Description .....               | 1,849 |
| Example .....                   | 1,849 |
| 17.66 LAST_DAY .....            | 1,851 |
| Syntax .....                    | 1,851 |
| Description .....               | 1,851 |
| Example .....                   | 1,851 |
| 17.67 LAST_IDENTITY_VALUE ..... | 1,852 |
| Syntax .....                    | 1,852 |
| Description .....               | 1,852 |
| Example .....                   | 1,853 |
| 17.68 LEAST .....               | 1,855 |
| Syntax .....                    | 1,855 |
| Description .....               | 1,855 |
| Example .....                   | 1,855 |
| 17.69 LENGTH .....              | 1,856 |
| Syntax .....                    | 1,856 |
| Description .....               | 1,856 |
| Example .....                   | 1,856 |
| 17.70 LENGTHB .....             | 1,857 |
| Syntax .....                    | 1,857 |
| Description .....               | 1,857 |
| Example .....                   | 1,857 |
| 17.71 LN .....                  | 1,858 |

|                               |       |
|-------------------------------|-------|
| Syntax .....                  | 1,858 |
| Description .....             | 1,858 |
| Example .....                 | 1,858 |
| 17.72 LNNVL .....             | 1,859 |
| Syntax .....                  | 1,859 |
| Description .....             | 1,859 |
| Example .....                 | 1,859 |
| 17.73 LOCALTIME .....         | 1,860 |
| Syntax .....                  | 1,860 |
| Description .....             | 1,860 |
| Example .....                 | 1,860 |
| 17.74 LOCALTIMESTAMP .....    | 1,861 |
| Syntax .....                  | 1,861 |
| Description .....             | 1,861 |
| Example .....                 | 1,861 |
| 17.75 LOCAL_GROUP_ID .....    | 1,862 |
| Syntax .....                  | 1,862 |
| Description .....             | 1,862 |
| Example .....                 | 1,862 |
| 17.76 LOCAL_GROUP_NAME .....  | 1,863 |
| Syntax .....                  | 1,863 |
| Description .....             | 1,863 |
| Example .....                 | 1,863 |
| 17.77 LOCAL_MEMBER_ID .....   | 1,864 |
| Syntax .....                  | 1,864 |
| Description .....             | 1,864 |
| Example .....                 | 1,864 |
| 17.78 LOCAL_MEMBER_NAME ..... | 1,865 |
| Syntax .....                  | 1,865 |
| Description .....             | 1,865 |
| Example .....                 | 1,865 |
| 17.79 LOG .....               | 1,866 |
| Syntax .....                  | 1,866 |
| Description .....             | 1,866 |
| Example .....                 | 1,866 |
| 17.80 LOGON_USER .....        | 1,867 |
| Syntax .....                  | 1,867 |
| Description .....             | 1,867 |
| Example .....                 | 1,867 |

|       |                |       |
|-------|----------------|-------|
| 17.81 | LOWER          | 1,868 |
|       | Syntax         | 1,868 |
|       | Description    | 1,868 |
|       | Example        | 1,868 |
| 17.82 | LPAD           | 1,869 |
|       | Syntax         | 1,869 |
|       | Description    | 1,869 |
|       | Example        | 1,870 |
| 17.83 | LTRIM          | 1,871 |
|       | Syntax         | 1,871 |
|       | Description    | 1,871 |
|       | Example        | 1,871 |
| 17.84 | MAX            | 1,872 |
|       | Syntax         | 1,872 |
|       | Description    | 1,872 |
|       | Example        | 1,872 |
| 17.85 | MIN            | 1,873 |
|       | Syntax         | 1,873 |
|       | Description    | 1,873 |
|       | Example        | 1,873 |
| 17.86 | MOD            | 1,874 |
|       | Syntax         | 1,874 |
|       | Description    | 1,874 |
|       | Example        | 1,874 |
| 17.87 | MONTHS_BETWEEN | 1,875 |
|       | Syntax         | 1,875 |
|       | Description    | 1,875 |
|       | Example        | 1,875 |
| 17.88 | NEXT_DAY       | 1,877 |
|       | Syntax         | 1,877 |
|       | Description    | 1,877 |
|       | Example        | 1,877 |
| 17.89 | NEXTVAL        | 1,879 |
|       | Syntax         | 1,879 |
|       | Description    | 1,879 |
|       | Example        | 1,879 |
| 17.90 | NULLIF         | 1,880 |
|       | Syntax         | 1,880 |
|       | Description    | 1,880 |

|                             |       |
|-----------------------------|-------|
| Example .....               | 1,880 |
| 17.91 NUMTODSINTERVAL ..... | 1,881 |
| Syntax .....                | 1,881 |
| Description .....           | 1,881 |
| Example .....               | 1,881 |
| 17.92 NUMTOYMINTERVAL ..... | 1,883 |
| Syntax .....                | 1,883 |
| Description .....           | 1,883 |
| Example .....               | 1,883 |
| 17.93 NVL .....             | 1,884 |
| Syntax .....                | 1,884 |
| Description .....           | 1,884 |
| Example .....               | 1,884 |
| 17.94 NVL2 .....            | 1,885 |
| Syntax .....                | 1,885 |
| Description .....           | 1,885 |
| Example .....               | 1,885 |
| 17.95 OCTET_LENGTH .....    | 1,886 |
| Syntax .....                | 1,886 |
| Description .....           | 1,886 |
| Example .....               | 1,886 |
| 17.96 OVERLAY .....         | 1,888 |
| Syntax .....                | 1,888 |
| Description .....           | 1,888 |
| Example .....               | 1,889 |
| 17.97 PHYSICAL_LENGTH ..... | 1,890 |
| Syntax .....                | 1,890 |
| Description .....           | 1,890 |
| Example .....               | 1,890 |
| 17.98 PI .....              | 1,892 |
| Syntax .....                | 1,892 |
| Description .....           | 1,892 |
| Example .....               | 1,892 |
| 17.99 POSITION .....        | 1,893 |
| Syntax .....                | 1,893 |
| Description .....           | 1,893 |
| Example .....               | 1,893 |
| 17.100 POWER .....          | 1,894 |
| Syntax .....                | 1,894 |

|                                   |       |
|-----------------------------------|-------|
| Description .....                 | 1,894 |
| Example .....                     | 1,894 |
| 17.101 RADIANS .....              | 1,895 |
| Syntax .....                      | 1,895 |
| Description .....                 | 1,895 |
| Example .....                     | 1,895 |
| 17.102 RANDOM .....               | 1,896 |
| Syntax .....                      | 1,896 |
| Description .....                 | 1,896 |
| Example .....                     | 1,896 |
| 17.103 REPEAT .....               | 1,897 |
| Syntax .....                      | 1,897 |
| Description .....                 | 1,897 |
| Example .....                     | 1,897 |
| 17.104 REPLACE .....              | 1,898 |
| Syntax .....                      | 1,898 |
| Description .....                 | 1,898 |
| Example .....                     | 1,898 |
| 17.105 REVERSE .....              | 1,899 |
| Syntax .....                      | 1,899 |
| Description .....                 | 1,899 |
| Example .....                     | 1,899 |
| 17.106 ROUND( number ) .....      | 1,901 |
| Syntax .....                      | 1,901 |
| Description .....                 | 1,901 |
| Example .....                     | 1,901 |
| 17.107 ROUND( date ) .....        | 1,902 |
| Syntax .....                      | 1,902 |
| Description .....                 | 1,902 |
| Example .....                     | 1,903 |
| 17.108 ROWID_GRID_BLOCK_ID .....  | 1,904 |
| Syntax .....                      | 1,904 |
| Description .....                 | 1,904 |
| Example .....                     | 1,904 |
| 17.109 ROWID_GRID_BLOCK_SEQ ..... | 1,905 |
| Syntax .....                      | 1,905 |
| Description .....                 | 1,905 |
| Example .....                     | 1,905 |
| 17.110 ROWID_MEMBER_ID .....      | 1,906 |

|                                  |       |
|----------------------------------|-------|
| Syntax .....                     | 1,906 |
| Description .....                | 1,906 |
| Example .....                    | 1,906 |
| 17.111 ROWID_OBJECT_ID .....     | 1,907 |
| Syntax .....                     | 1,907 |
| Description .....                | 1,907 |
| Example .....                    | 1,907 |
| 17.112 ROWID_PAGE_ID .....       | 1,908 |
| Syntax .....                     | 1,908 |
| Description .....                | 1,908 |
| Example .....                    | 1,908 |
| 17.113 ROWID_ROW_NUMBER .....    | 1,909 |
| Syntax .....                     | 1,909 |
| Description .....                | 1,909 |
| Example .....                    | 1,909 |
| 17.114 ROWID_SHARD_ID .....      | 1,910 |
| Syntax .....                     | 1,910 |
| Description .....                | 1,910 |
| Example .....                    | 1,910 |
| 17.115 ROWID_TABLESPACE_ID ..... | 1,911 |
| Syntax .....                     | 1,911 |
| Description .....                | 1,911 |
| Example .....                    | 1,911 |
| 17.116 ROWNUM .....              | 1,912 |
| Syntax .....                     | 1,912 |
| Description .....                | 1,912 |
| Example .....                    | 1,915 |
| 17.117 RPAD .....                | 1,916 |
| Syntax .....                     | 1,916 |
| Description .....                | 1,916 |
| Example .....                    | 1,916 |
| 17.118 RTRIM .....               | 1,918 |
| Syntax .....                     | 1,918 |
| Description .....                | 1,918 |
| Example .....                    | 1,918 |
| 17.119 SESSION_ID .....          | 1,920 |
| Syntax .....                     | 1,920 |
| Description .....                | 1,920 |
| Example .....                    | 1,920 |

|        |                  |       |
|--------|------------------|-------|
| 17.120 | SESSION_SERIAL   | 1,921 |
|        | Syntax           | 1,921 |
|        | Description      | 1,921 |
|        | Example          | 1,921 |
| 17.121 | SESSION_USER     | 1,922 |
|        | Syntax           | 1,922 |
|        | Description      | 1,922 |
|        | Example          | 1,922 |
| 17.122 | SHARD_GROUP_ID   | 1,923 |
|        | Syntax           | 1,923 |
|        | Description      | 1,923 |
|        | Example          | 1,923 |
| 17.123 | SHARD_GROUP_NAME | 1,925 |
|        | Syntax           | 1,925 |
|        | Description      | 1,925 |
|        | Example          | 1,925 |
| 17.124 | SHARD_ID         | 1,927 |
|        | Syntax           | 1,927 |
|        | Description      | 1,927 |
|        | Example          | 1,927 |
| 17.125 | SHARD_NAME       | 1,929 |
|        | Syntax           | 1,929 |
|        | Description      | 1,929 |
|        | Example          | 1,929 |
| 17.126 | SHIFT_LEFT       | 1,931 |
|        | Syntax           | 1,931 |
|        | Description      | 1,931 |
|        | Example          | 1,931 |
| 17.127 | SHIFT_RIGHT      | 1,932 |
|        | Syntax           | 1,932 |
|        | Description      | 1,932 |
|        | Example          | 1,932 |
| 17.128 | SIGN             | 1,933 |
|        | Syntax           | 1,933 |
|        | Description      | 1,933 |
|        | Example          | 1,933 |
| 17.129 | SIN              | 1,934 |
|        | Syntax           | 1,934 |
|        | Description      | 1,934 |



|                                       |       |
|---------------------------------------|-------|
| Example .....                         | 1,934 |
| 17.130 SPLIT_PART .....               | 1,935 |
| Syntax .....                          | 1,935 |
| Description .....                     | 1,935 |
| Example .....                         | 1,935 |
| 17.131 SQRT .....                     | 1,936 |
| Syntax .....                          | 1,936 |
| Description .....                     | 1,936 |
| Example .....                         | 1,936 |
| 17.132 STATEMENT_DATE .....           | 1,937 |
| Syntax .....                          | 1,937 |
| Description .....                     | 1,937 |
| Example .....                         | 1,937 |
| 17.133 STATEMENT_LOCALTIME .....      | 1,938 |
| Syntax .....                          | 1,938 |
| Description .....                     | 1,938 |
| Example .....                         | 1,938 |
| 17.134 STATEMENT_LOCALTIMESTAMP ..... | 1,939 |
| Syntax .....                          | 1,939 |
| Description .....                     | 1,939 |
| Example .....                         | 1,939 |
| 17.135 STATEMENT_TIME .....           | 1,940 |
| Syntax .....                          | 1,940 |
| Description .....                     | 1,940 |
| Example .....                         | 1,940 |
| 17.136 STATEMENT_TIMESTAMP .....      | 1,941 |
| Syntax .....                          | 1,941 |
| Description .....                     | 1,941 |
| Example .....                         | 1,941 |
| 17.137 STATEMENT_VIEW_SCN .....       | 1,942 |
| Syntax .....                          | 1,942 |
| Description .....                     | 1,942 |
| Example .....                         | 1,942 |
| 17.138 STATEMENT_VIEW_SCN_DCN .....   | 1,943 |
| Syntax .....                          | 1,943 |
| Description .....                     | 1,943 |
| Example .....                         | 1,943 |
| 17.139 STATEMENT_VIEW_SCN_GCN .....   | 1,944 |
| Syntax .....                          | 1,944 |

|                                     |       |
|-------------------------------------|-------|
| Description .....                   | 1,944 |
| Example .....                       | 1,944 |
| 17.140 STATEMENT_VIEW_SCN_LCN ..... | 1,945 |
| Syntax .....                        | 1,945 |
| Description .....                   | 1,945 |
| Example .....                       | 1,945 |
| 17.141 STDDEV .....                 | 1,946 |
| Syntax .....                        | 1,946 |
| Description .....                   | 1,946 |
| Example .....                       | 1,947 |
| 17.142 STDDEV_POP .....             | 1,948 |
| Syntax .....                        | 1,948 |
| Description .....                   | 1,948 |
| Example .....                       | 1,949 |
| 17.143 STDDEV_SAMP .....            | 1,950 |
| Syntax .....                        | 1,950 |
| Description .....                   | 1,950 |
| Example .....                       | 1,951 |
| 17.144 SUBSTR .....                 | 1,952 |
| Syntax .....                        | 1,952 |
| Description .....                   | 1,952 |
| Example .....                       | 1,952 |
| 17.145 SUBSTRB .....                | 1,953 |
| Syntax .....                        | 1,953 |
| Description .....                   | 1,953 |
| Example .....                       | 1,953 |
| 17.146 SUBSTRING .....              | 1,954 |
| Syntax .....                        | 1,954 |
| Description .....                   | 1,954 |
| Example .....                       | 1,955 |
| 17.147 SUM .....                    | 1,956 |
| Syntax .....                        | 1,956 |
| Description .....                   | 1,956 |
| Example .....                       | 1,956 |
| 17.148 SYSDATE .....                | 1,957 |
| Syntax .....                        | 1,957 |
| Description .....                   | 1,957 |
| Example .....                       | 1,957 |
| 17.149 SYS_EXTRACT_UTC .....        | 1,958 |

|                                  |       |
|----------------------------------|-------|
| Syntax .....                     | 1,958 |
| Description .....                | 1,958 |
| Example .....                    | 1,958 |
| 17.150 SYSTIME .....             | 1,959 |
| Syntax .....                     | 1,959 |
| Description .....                | 1,959 |
| Example .....                    | 1,959 |
| 17.151 SYSTIMESTAMP .....        | 1,960 |
| Syntax .....                     | 1,960 |
| Description .....                | 1,960 |
| Example .....                    | 1,960 |
| 17.152 TAN .....                 | 1,961 |
| Syntax .....                     | 1,961 |
| Description .....                | 1,961 |
| Example .....                    | 1,961 |
| 17.153 TO_BASE64 .....           | 1,962 |
| Syntax .....                     | 1,962 |
| Description .....                | 1,962 |
| Example .....                    | 1,962 |
| 17.154 TO_CHAR( datetime ) ..... | 1,963 |
| Syntax .....                     | 1,963 |
| Description .....                | 1,963 |
| Example .....                    | 1,963 |
| 17.155 TO_CHAR( number ) .....   | 1,965 |
| Syntax .....                     | 1,965 |
| Description .....                | 1,965 |
| Example .....                    | 1,965 |
| 17.156 TO_DATE .....             | 1,966 |
| Syntax .....                     | 1,966 |
| Description .....                | 1,966 |
| Example .....                    | 1,966 |
| 17.157 TO_NATIVE_BIGINT .....    | 1,968 |
| Syntax .....                     | 1,968 |
| Description .....                | 1,968 |
| Example .....                    | 1,968 |
| 17.158 TO_NATIVE_DOUBLE .....    | 1,969 |
| Syntax .....                     | 1,969 |
| Description .....                | 1,969 |
| Example .....                    | 1,969 |

|        |                             |       |
|--------|-----------------------------|-------|
| 17.159 | TO_NATIVE_INTEGER           | 1,970 |
|        | Syntax                      | 1,970 |
|        | Description                 | 1,970 |
|        | Example                     | 1,970 |
| 17.160 | TO_NATIVE_REAL              | 1,971 |
|        | Syntax                      | 1,971 |
|        | Description                 | 1,971 |
|        | Example                     | 1,971 |
| 17.161 | TO_NATIVE_SMALLINT          | 1,972 |
|        | Syntax                      | 1,972 |
|        | Description                 | 1,972 |
|        | Example                     | 1,972 |
| 17.162 | TO_NUMBER                   | 1,973 |
|        | Syntax                      | 1,973 |
|        | Description                 | 1,973 |
|        | Example                     | 1,973 |
| 17.163 | TO_TIME                     | 1,974 |
|        | Syntax                      | 1,974 |
|        | Description                 | 1,974 |
|        | Example                     | 1,974 |
| 17.164 | TO_TIME_TZ                  | 1,976 |
|        | Syntax                      | 1,976 |
|        | Description                 | 1,976 |
|        | Example                     | 1,976 |
| 17.165 | TO_TIME_WITH_TIME_ZONE      | 1,977 |
|        | Syntax                      | 1,977 |
|        | Description                 | 1,977 |
|        | Example                     | 1,977 |
| 17.166 | TO_TIMESTAMP                | 1,979 |
|        | Syntax                      | 1,979 |
|        | Description                 | 1,979 |
|        | Example                     | 1,979 |
| 17.167 | TO_TIMESTAMP_TZ             | 1,981 |
|        | Syntax                      | 1,981 |
|        | Description                 | 1,981 |
|        | Example                     | 1,981 |
| 17.168 | TO_TIMESTAMP_WITH_TIME_ZONE | 1,982 |
|        | Syntax                      | 1,982 |
|        | Description                 | 1,982 |

|                                         |       |
|-----------------------------------------|-------|
| Example .....                           | 1,982 |
| 17.169 TRANSACTION_DATE .....           | 1,984 |
| Syntax .....                            | 1,984 |
| Description .....                       | 1,984 |
| Example .....                           | 1,984 |
| 17.170 TRANSACTION_LOCALTIME .....      | 1,985 |
| Syntax .....                            | 1,985 |
| Description .....                       | 1,985 |
| Example .....                           | 1,985 |
| 17.171 TRANSACTION_LOCALTIMESTAMP ..... | 1,986 |
| Syntax .....                            | 1,986 |
| Description .....                       | 1,986 |
| Example .....                           | 1,986 |
| 17.172 TRANSACTION_TIME .....           | 1,987 |
| Syntax .....                            | 1,987 |
| Description .....                       | 1,987 |
| Example .....                           | 1,987 |
| 17.173 TRANSACTION_TIMESTAMP .....      | 1,988 |
| Syntax .....                            | 1,988 |
| Description .....                       | 1,988 |
| Example .....                           | 1,988 |
| 17.174 TRANSLATE .....                  | 1,989 |
| Syntax .....                            | 1,989 |
| Description .....                       | 1,989 |
| Example .....                           | 1,990 |
| 17.175 TRIM .....                       | 1,991 |
| Syntax .....                            | 1,991 |
| Description .....                       | 1,991 |
| Example .....                           | 1,992 |
| 17.176 TRUNC( number ) .....            | 1,993 |
| Syntax .....                            | 1,993 |
| Description .....                       | 1,993 |
| Example .....                           | 1,993 |
| 17.177 TRUNC( date ) .....              | 1,994 |
| Syntax .....                            | 1,994 |
| Description .....                       | 1,994 |
| Example .....                           | 1,995 |
| 17.178 UPPER .....                      | 1,996 |
| Syntax .....                            | 1,996 |

|                                       |              |
|---------------------------------------|--------------|
| Description .....                     | 1,996        |
| Example .....                         | 1,996        |
| 17.179 UNHEX .....                    | 1,997        |
| Syntax .....                          | 1,997        |
| Description .....                     | 1,997        |
| Example .....                         | 1,997        |
| 17.180 UNHEX_TO_CHARSTR .....         | 1,998        |
| Syntax .....                          | 1,998        |
| Description .....                     | 1,998        |
| Example .....                         | 1,998        |
| 17.181 USER_ID .....                  | 1,999        |
| Syntax .....                          | 1,999        |
| Description .....                     | 1,999        |
| Example .....                         | 1,999        |
| 17.182 UUID .....                     | 2,000        |
| Syntax .....                          | 2,000        |
| Description .....                     | 2,000        |
| Example .....                         | 2,000        |
| 17.183 VAR_POP .....                  | 2,001        |
| Syntax .....                          | 2,001        |
| Description .....                     | 2,001        |
| Example .....                         | 2,002        |
| 17.184 VAR_SAMP .....                 | 2,003        |
| Syntax .....                          | 2,003        |
| Description .....                     | 2,003        |
| Example .....                         | 2,004        |
| 17.185 VARIANCE .....                 | 2,005        |
| Syntax .....                          | 2,005        |
| Description .....                     | 2,005        |
| Example .....                         | 2,006        |
| 17.186 VERSION .....                  | 2,007        |
| Syntax .....                          | 2,007        |
| Description .....                     | 2,007        |
| Example .....                         | 2,007        |
| 17.187 WIDTH_BUCKET .....             | 2,008        |
| Syntax .....                          | 2,008        |
| Description .....                     | 2,008        |
| Example .....                         | 2,008        |
| <b>18. SQL References (A~B) .....</b> | <b>2,009</b> |

|                                                    |       |
|----------------------------------------------------|-------|
| 18.1 ALTER AUDIT POLICY .....                      | 2,010 |
| Function .....                                     | 2,010 |
| Syntax .....                                       | 2,010 |
| Invocation and Access Rules .....                  | 2,010 |
| Syntax Rules and Parameters .....                  | 2,011 |
| Description .....                                  | 2,011 |
| Examples .....                                     | 2,012 |
| Compatibility .....                                | 2,012 |
| For More Information .....                         | 2,012 |
| 18.2 ALTER CLUSTER GROUP name ADD MEMBER .....     | 2,013 |
| Function .....                                     | 2,013 |
| Syntax .....                                       | 2,013 |
| Invocation and Access Rules .....                  | 2,013 |
| Syntax Rules and Parameters .....                  | 2,013 |
| Description .....                                  | 2,015 |
| Examples .....                                     | 2,015 |
| Compatibility .....                                | 2,016 |
| For More Information .....                         | 2,016 |
| 18.3 ALTER CLUSTER GROUP name OFFLINE MEMBER ..... | 2,017 |
| Function .....                                     | 2,017 |
| Syntax .....                                       | 2,017 |
| Invocation and Access Rules .....                  | 2,017 |
| Syntax Rules and Parameters .....                  | 2,017 |
| Description .....                                  | 2,018 |
| Examples .....                                     | 2,018 |
| Compatibility .....                                | 2,018 |
| For More Information .....                         | 2,018 |
| 18.4 ALTER CLUSTER LOCATION .....                  | 2,019 |
| Function .....                                     | 2,019 |
| Syntax .....                                       | 2,019 |
| Invocation and Access Rules .....                  | 2,019 |
| Syntax Rules and Parameters .....                  | 2,019 |
| Description .....                                  | 2,020 |
| Examples .....                                     | 2,020 |
| Compatibility .....                                | 2,020 |
| For More Information .....                         | 2,020 |
| 18.5 ALTER DATABASE ADD LOGFILE .....              | 2,021 |
| Function .....                                     | 2,021 |
| Syntax .....                                       | 2,021 |

|                                            |       |
|--------------------------------------------|-------|
| Invocation and Access Rules                | 2,021 |
| Syntax Rules and Parameters                | 2,021 |
| Description                                | 2,022 |
| Examples                                   | 2,023 |
| Compatibility                              | 2,023 |
| For More Information                       | 2,023 |
| 18.6 ALTER DATABASE ARCHIVELOG             | 2,024 |
| Function                                   | 2,024 |
| Syntax                                     | 2,024 |
| Invocation and Access Rules                | 2,024 |
| Syntax Rules and Parameters                | 2,024 |
| Description                                | 2,024 |
| Example                                    | 2,025 |
| Compatibility                              | 2,025 |
| For More Information                       | 2,025 |
| 18.7 ALTER DATABASE BACKUP                 | 2,026 |
| Function                                   | 2,026 |
| Syntax                                     | 2,026 |
| Invocation and Access Rules                | 2,026 |
| Syntax Rules and Parameters                | 2,027 |
| Description                                | 2,028 |
| Examples                                   | 2,028 |
| Compatibility                              | 2,029 |
| For More Information                       | 2,029 |
| 18.8 ALTER DATABASE CLEAR AUDIT TRAIL      | 2,030 |
| Function                                   | 2,030 |
| Syntax                                     | 2,030 |
| Invocation and Access Rules                | 2,030 |
| Description                                | 2,030 |
| Storing Audit Trail                        | 2,030 |
| Examples                                   | 2,031 |
| Compatibility                              | 2,031 |
| For More Information                       | 2,031 |
| 18.9 ALTER DATABASE CLEAR PASSWORD HISTORY | 2,032 |
| Function                                   | 2,032 |
| Syntax                                     | 2,032 |
| Invocation and Access Rules                | 2,032 |
| Description                                | 2,032 |
| Examples                                   | 2,033 |



|                                                          |       |
|----------------------------------------------------------|-------|
| Compatibility .....                                      | 2,033 |
| For More Information .....                               | 2,033 |
| 18.10 ALTER DATABASE DATAFILE AUTOEXTEND .....           | 2,034 |
| Function .....                                           | 2,034 |
| Syntax .....                                             | 2,034 |
| Invocation and Access Rules .....                        | 2,034 |
| Description .....                                        | 2,035 |
| Examples .....                                           | 2,035 |
| Compatibility .....                                      | 2,035 |
| For More Information .....                               | 2,036 |
| 18.11 ALTER DATABASE DELETE BACKUP .....                 | 2,037 |
| Function .....                                           | 2,037 |
| Syntax .....                                             | 2,037 |
| Invocation and Access Rules .....                        | 2,037 |
| Syntax Rules and Parameters .....                        | 2,037 |
| Description .....                                        | 2,038 |
| Example .....                                            | 2,038 |
| Compatibility .....                                      | 2,038 |
| For More Information .....                               | 2,039 |
| 18.12 ALTER DATABASE DROP INACTIVE CLUSTER MEMBERS ..... | 2,040 |
| Function .....                                           | 2,040 |
| Syntax .....                                             | 2,040 |
| Invocation and Access Rules .....                        | 2,040 |
| Syntax Rules and Parameters .....                        | 2,040 |
| Description .....                                        | 2,041 |
| Examples .....                                           | 2,041 |
| Compatibility .....                                      | 2,041 |
| For More Information .....                               | 2,042 |
| 18.13 ALTER DATABASE DROP LOGFILE .....                  | 2,043 |
| Function .....                                           | 2,043 |
| Syntax .....                                             | 2,043 |
| Invocation and Access Rules .....                        | 2,043 |
| Syntax Rules and Parameters .....                        | 2,043 |
| Description .....                                        | 2,044 |
| Examples .....                                           | 2,044 |
| Compatibility .....                                      | 2,044 |
| For More Information .....                               | 2,045 |
| 18.14 ALTER DATABASE MOVE SHARD .....                    | 2,046 |
| Function .....                                           | 2,046 |

|                                                       |       |
|-------------------------------------------------------|-------|
| Syntax                                                | 2,046 |
| Invocation and Access Rules                           | 2,046 |
| Syntax Rules and Parameters                           | 2,046 |
| Description                                           | 2,047 |
| Examples                                              | 2,048 |
| Compatibility                                         | 2,048 |
| For More Information                                  | 2,048 |
| 18.15 ALTER DATABASE OFFLINE INACTIVE CLUSTER MEMBERS | 2,049 |
| Function                                              | 2,049 |
| Syntax                                                | 2,049 |
| Invocation and Access Rules                           | 2,049 |
| Syntax Rules and Parameters                           | 2,049 |
| Description                                           | 2,050 |
| Examples                                              | 2,050 |
| Compatibility                                         | 2,050 |
| For More Information                                  | 2,050 |
| 18.16 ALTER DATABASE REBALANCE                        | 2,051 |
| Function                                              | 2,051 |
| Syntax                                                | 2,051 |
| Invocation and Access Rules                           | 2,051 |
| Syntax Rules and Parameters                           | 2,051 |
| Description                                           | 2,052 |
| Examples                                              | 2,052 |
| Compatibility                                         | 2,053 |
| For More Information                                  | 2,053 |
| 18.17 ALTER DATABASE REBALANCE EXCLUDE CLUSTER GROUP  | 2,054 |
| Function                                              | 2,054 |
| Syntax                                                | 2,054 |
| Invocation and Access Rules                           | 2,054 |
| Syntax Rules and Parameters                           | 2,054 |
| Description                                           | 2,055 |
| Examples                                              | 2,055 |
| Compatibility                                         | 2,056 |
| For More Information                                  | 2,056 |
| 18.18 ALTER DATABASE RECOVER                          | 2,057 |
| Function                                              | 2,057 |
| Syntax                                                | 2,057 |
| Invocation and Access Rules                           | 2,058 |
| Syntax Rules and Parameters                           | 2,058 |

|                                                       |       |
|-------------------------------------------------------|-------|
| Description .....                                     | 2,060 |
| Examples .....                                        | 2,060 |
| Compatibility .....                                   | 2,061 |
| For More Information .....                            | 2,061 |
| 18.19 ALTER DATABASE REGISTER .....                   | 2,062 |
| Function .....                                        | 2,062 |
| Syntax .....                                          | 2,062 |
| Invocation and Access Rules .....                     | 2,062 |
| Syntax Rules and Parameters .....                     | 2,062 |
| Description .....                                     | 2,063 |
| Example .....                                         | 2,063 |
| Compatibility .....                                   | 2,063 |
| For More Information .....                            | 2,063 |
| 18.20 ALTER DATABASE RENAME LOGFILE .....             | 2,064 |
| Function .....                                        | 2,064 |
| Syntax .....                                          | 2,064 |
| Invocation and Access Rules .....                     | 2,064 |
| Syntax Rules and Parameters .....                     | 2,064 |
| Description .....                                     | 2,065 |
| Example .....                                         | 2,065 |
| Compatibility .....                                   | 2,065 |
| For More Information .....                            | 2,065 |
| 18.21 ALTER DATABASE RESET LOCAL CLUSTER MEMBER ..... | 2,066 |
| Function .....                                        | 2,066 |
| Syntax .....                                          | 2,066 |
| Invocation and Access Rules .....                     | 2,066 |
| Description .....                                     | 2,066 |
| Examples .....                                        | 2,067 |
| Compatibility .....                                   | 2,067 |
| For More Information .....                            | 2,067 |
| 18.22 ALTER DATABASE RESTORE .....                    | 2,068 |
| Function .....                                        | 2,068 |
| Syntax .....                                          | 2,068 |
| Invocation and Access Rules .....                     | 2,068 |
| Syntax Rules and Parameters .....                     | 2,068 |
| Description .....                                     | 2,069 |
| Examples .....                                        | 2,069 |
| Compatibility .....                                   | 2,070 |
| For More Information .....                            | 2,070 |

|                                  |       |
|----------------------------------|-------|
| 18.23 ALTER INDEX                | 2,071 |
| Function                         | 2,071 |
| Syntax                           | 2,071 |
| Invocation and Access Rules      | 2,071 |
| Syntax Rules and Parameters      | 2,071 |
| Description                      | 2,072 |
| Examples                         | 2,072 |
| Compatibility                    | 2,072 |
| 18.24 ALTER INDEX name AGING     | 2,073 |
| Function                         | 2,073 |
| Syntax                           | 2,073 |
| Invocation and Access Rules      | 2,073 |
| Syntax Rules and Parameters      | 2,073 |
| Description                      | 2,073 |
| Examples                         | 2,074 |
| Compatibility                    | 2,074 |
| For More Information             | 2,074 |
| 18.25 ALTER INDEX name REBUILD   | 2,075 |
| Function                         | 2,075 |
| Syntax                           | 2,075 |
| Invocation and Access Rules      | 2,076 |
| Syntax Rules and Parameters      | 2,076 |
| Description                      | 2,079 |
| Examples                         | 2,079 |
| Compatibility                    | 2,080 |
| For More Information             | 2,080 |
| 18.26 ALTER INDEX name RENAME TO | 2,081 |
| Function                         | 2,081 |
| Syntax                           | 2,081 |
| Invocation and Access Rules      | 2,081 |
| Syntax Rules and Parameters      | 2,081 |
| Description                      | 2,082 |
| Examples                         | 2,082 |
| Compatibility                    | 2,082 |
| For More Information             | 2,082 |
| 18.27 ALTER INDEX name STORAGE   | 2,083 |
| Function                         | 2,083 |
| Syntax                           | 2,083 |
| Invocation and Access Rules      | 2,083 |

|                                                            |       |
|------------------------------------------------------------|-------|
| Syntax Rules and Parameters                                | 2,084 |
| Description                                                | 2,086 |
| Examples                                                   | 2,086 |
| Compatibility                                              | 2,086 |
| For More Information                                       | 2,086 |
| 18.28 ALTER PROFILE                                        | 2,087 |
| Function                                                   | 2,087 |
| Syntax                                                     | 2,087 |
| Invocation and Access Rules                                | 2,087 |
| Syntax Rules and Parameters                                | 2,088 |
| Examples                                                   | 2,089 |
| Compatibility                                              | 2,090 |
| For More Information                                       | 2,090 |
| 18.29 ALTER SEQUENCE                                       | 2,091 |
| Function                                                   | 2,091 |
| Syntax                                                     | 2,091 |
| Invocation and Access Rules                                | 2,092 |
| Syntax Rules and Parameters                                | 2,092 |
| Description                                                | 2,094 |
| Examples                                                   | 2,095 |
| Compatibility                                              | 2,095 |
| For More Information                                       | 2,096 |
| 18.30 ALTER SESSION CLEANUP GLOBAL TEMPORARY SEGMENT POOL; | 2,097 |
| Function                                                   | 2,097 |
| Syntax                                                     | 2,097 |
| Description                                                | 2,097 |
| Examples                                                   | 2,097 |
| Compatibility                                              | 2,097 |
| For More Information                                       | 2,098 |
| 18.31 ALTER SESSION SET property_name                      | 2,099 |
| Function                                                   | 2,099 |
| Syntax                                                     | 2,099 |
| Syntax Rules and Parameters                                | 2,099 |
| Description                                                | 2,099 |
| Examples                                                   | 2,100 |
| Compatibility                                              | 2,100 |
| For More Information                                       | 2,100 |
| 18.32 ALTER SYSTEM CHECKPOINT                              | 2,101 |
| Function                                                   | 2,101 |

|                                                 |       |
|-------------------------------------------------|-------|
| Syntax                                          | 2,101 |
| Invocation and Access Rules                     | 2,101 |
| Syntax Rules and Parameters                     | 2,101 |
| Description                                     | 2,102 |
| Example                                         | 2,102 |
| Compatibility                                   | 2,102 |
| 18.33 ALTER SYSTEM CLEANUP BUFFER_CACHE         | 2,103 |
| Function                                        | 2,103 |
| Syntax                                          | 2,103 |
| Invocation and Access Rules                     | 2,103 |
| Syntax Rules and Parameters                     | 2,103 |
| Description                                     | 2,104 |
| Example                                         | 2,104 |
| Compatibility                                   | 2,104 |
| 18.34 ALTER SYSTEM CLEANUP PLAN                 | 2,105 |
| Function                                        | 2,105 |
| Syntax                                          | 2,105 |
| Invocation and Access Rules                     | 2,105 |
| Syntax Rules and Parameters                     | 2,105 |
| Description                                     | 2,105 |
| Examples                                        | 2,106 |
| Compatibility                                   | 2,106 |
| 18.35 ALTER SYSTEM IRRECOVERABLE CLUSTER MEMBER | 2,107 |
| Function                                        | 2,107 |
| Syntax                                          | 2,107 |
| Invocation and Access Rules                     | 2,107 |
| Syntax Rules and Parameters                     | 2,107 |
| Description                                     | 2,108 |
| Examples                                        | 2,108 |
| Compatibility                                   | 2,108 |
| 18.36 ALTER SYSTEM JOIN DATABASE                | 2,109 |
| Function                                        | 2,109 |
| Syntax                                          | 2,109 |
| Invocation and Access Rules                     | 2,109 |
| Description                                     | 2,109 |
| Examples                                        | 2,110 |
| Compatibility                                   | 2,110 |
| For More Information                            | 2,111 |
| 18.37 ALTER SYSTEM [KILL   DISCONNECT] SESSION  | 2,112 |

|                                                |       |
|------------------------------------------------|-------|
| Function                                       | 2,112 |
| Syntax                                         | 2,112 |
| Invocation and Access Rules                    | 2,112 |
| Syntax Rules and Parameters                    | 2,112 |
| Description                                    | 2,113 |
| Example                                        | 2,113 |
| Compatibility                                  | 2,114 |
| 18.38 ALTER SYSTEM {MOUNT   OPEN} DATABASE     | 2,115 |
| Function                                       | 2,115 |
| Syntax                                         | 2,115 |
| Invocation and Access Rules                    | 2,115 |
| Syntax Rules and Parameters                    | 2,115 |
| Examples                                       | 2,116 |
| Compatibility                                  | 2,116 |
| For More Information                           | 2,117 |
| 18.39 ALTER SYSTEM RECONNECT GLOBAL CONNECTION | 2,118 |
| Function                                       | 2,118 |
| Syntax                                         | 2,118 |
| Invocation and Access Rules                    | 2,118 |
| Description                                    | 2,118 |
| Examples                                       | 2,119 |
| Compatibility                                  | 2,119 |
| 18.40 ALTER SYSTEM RESET property_name         | 2,120 |
| Function                                       | 2,120 |
| Syntax                                         | 2,120 |
| Invocation and Access Rules                    | 2,120 |
| Syntax Rules and Parameters                    | 2,120 |
| Description                                    | 2,121 |
| Examples                                       | 2,121 |
| Compatibility                                  | 2,122 |
| For More Information                           | 2,122 |
| 18.41 ALTER SYSTEM SET property_name           | 2,123 |
| Function                                       | 2,123 |
| Syntax                                         | 2,123 |
| Invocation and Access Rules                    | 2,123 |
| Syntax Rules and Parameters                    | 2,123 |
| Description                                    | 2,125 |
| Examples                                       | 2,125 |
| Compatibility                                  | 2,125 |

|                                                         |       |
|---------------------------------------------------------|-------|
| For More Information .....                              | 2,126 |
| 18.42 ALTER SYSTEM SWITCH LOGFILE .....                 | 2,127 |
| Function .....                                          | 2,127 |
| Syntax .....                                            | 2,127 |
| Invocation and Access Rules .....                       | 2,127 |
| Syntax Rules and Parameters .....                       | 2,127 |
| Description .....                                       | 2,128 |
| Example .....                                           | 2,128 |
| Compatibility .....                                     | 2,128 |
| For More Information .....                              | 2,128 |
| 18.43 ALTER TABLE .....                                 | 2,129 |
| Function .....                                          | 2,129 |
| Syntax .....                                            | 2,129 |
| Invocation and Access Rules .....                       | 2,129 |
| Syntax Rules and Parameters .....                       | 2,130 |
| Description .....                                       | 2,132 |
| Example .....                                           | 2,132 |
| Compatibility .....                                     | 2,133 |
| 18.44 ALTER TABLE name ADD COLUMN .....                 | 2,134 |
| Function .....                                          | 2,134 |
| Syntax .....                                            | 2,134 |
| Invocation and Access Rules .....                       | 2,134 |
| Syntax Rules and Parameters .....                       | 2,135 |
| Description .....                                       | 2,136 |
| Examples .....                                          | 2,136 |
| Compatibility .....                                     | 2,137 |
| For More Information .....                              | 2,137 |
| 18.45 ALTER TABLE name ADD CONSTRAINT .....             | 2,138 |
| Function .....                                          | 2,138 |
| Syntax .....                                            | 2,138 |
| Invocation and Access Rules .....                       | 2,138 |
| Syntax Rules and Parameters .....                       | 2,139 |
| Description .....                                       | 2,139 |
| Examples .....                                          | 2,139 |
| Compatibility .....                                     | 2,140 |
| For More Information .....                              | 2,140 |
| 18.46 ALTER TABLE name ADD GLOBAL SECONDARY INDEX ..... | 2,141 |
| Function .....                                          | 2,141 |
| Syntax .....                                            | 2,141 |



|                                                           |       |
|-----------------------------------------------------------|-------|
| Invocation and Access Rules .....                         | 2,142 |
| Syntax Rules and Parameters .....                         | 2,142 |
| Description .....                                         | 2,145 |
| Examples .....                                            | 2,145 |
| Compatibility .....                                       | 2,146 |
| For More Information .....                                | 2,146 |
| 18.47 ALTER TABLE name ADD SUPPLEMENTAL LOG .....         | 2,147 |
| Function .....                                            | 2,147 |
| Syntax .....                                              | 2,147 |
| Invocation and Access Rules .....                         | 2,147 |
| Syntax Rules and Parameters .....                         | 2,147 |
| Description .....                                         | 2,148 |
| Example .....                                             | 2,148 |
| Compatibility .....                                       | 2,148 |
| For More Information .....                                | 2,148 |
| 18.48 ALTER TABLE name ALTER COLUMN .....                 | 2,149 |
| Function .....                                            | 2,149 |
| Syntax .....                                              | 2,149 |
| Invocation and Access Rules .....                         | 2,150 |
| Syntax Rules and Parameters .....                         | 2,150 |
| Description .....                                         | 2,158 |
| Examples .....                                            | 2,159 |
| Compatibility .....                                       | 2,160 |
| For More Information .....                                | 2,160 |
| 18.49 ALTER TABLE name ALTER CONSTRAINT .....             | 2,161 |
| Function .....                                            | 2,161 |
| Syntax .....                                              | 2,161 |
| Invocation and Access Rules .....                         | 2,161 |
| Syntax Rules and Parameters .....                         | 2,162 |
| Description .....                                         | 2,163 |
| Example .....                                             | 2,163 |
| Compatibility .....                                       | 2,163 |
| 18.50 ALTER TABLE name ALTER GLOBAL SECONDARY INDEX ..... | 2,164 |
| Function .....                                            | 2,164 |
| Syntax .....                                              | 2,164 |
| Invocation and Access Rules .....                         | 2,164 |
| Syntax Rules and Parameters .....                         | 2,165 |
| Description .....                                         | 2,167 |
| Examples .....                                            | 2,167 |

|                                                    |       |
|----------------------------------------------------|-------|
| Compatibility                                      | 2,167 |
| For More Information                               | 2,168 |
| 18.51 ALTER TABLE name DROP CONSTRAINT             | 2,169 |
| Function                                           | 2,169 |
| Syntax                                             | 2,169 |
| Invocation and Access Rules                        | 2,169 |
| Syntax Rules and Parameters                        | 2,170 |
| Description                                        | 2,170 |
| Examples                                           | 2,170 |
| Compatibility                                      | 2,171 |
| For More Information                               | 2,171 |
| 18.52 ALTER TABLE name DROP GLOBAL SECONDARY INDEX | 2,172 |
| Function                                           | 2,172 |
| Syntax                                             | 2,172 |
| Invocation and Access Rules                        | 2,172 |
| Syntax Rules and Parameters                        | 2,172 |
| Description                                        | 2,173 |
| Examples                                           | 2,173 |
| Compatibility                                      | 2,173 |
| For More Information                               | 2,173 |
| 18.53 ALTER TABLE name DROP SUPPLEMENTAL LOG       | 2,174 |
| Function                                           | 2,174 |
| Syntax                                             | 2,174 |
| Invocation and Access Rules                        | 2,174 |
| Syntax Rules and Parameters                        | 2,174 |
| Description                                        | 2,175 |
| Example                                            | 2,175 |
| Compatibility                                      | 2,175 |
| 18.54 ALTER TABLE name MERGE SHARDS                | 2,176 |
| Function                                           | 2,176 |
| Syntax                                             | 2,176 |
| Invocation and Access Rules                        | 2,176 |
| Syntax Rules and Parameters                        | 2,176 |
| Description                                        | 2,177 |
| Examples                                           | 2,178 |
| Compatibility                                      | 2,179 |
| For More Information                               | 2,179 |
| 18.55 ALTER TABLE name MOVE SHARD                  | 2,180 |
| Function                                           | 2,180 |

|                                                                           |       |
|---------------------------------------------------------------------------|-------|
| Syntax                                                                    | 2,180 |
| Invocation and Access Rules                                               | 2,180 |
| Syntax Rules and Parameters                                               | 2,180 |
| Description                                                               | 2,181 |
| Examples                                                                  | 2,182 |
| Compatibility                                                             | 2,182 |
| For More Information                                                      | 2,182 |
| 18.56 ALTER TABLE name READ { ONLY   WRITE }                              | 2,183 |
| Function                                                                  | 2,183 |
| Syntax                                                                    | 2,183 |
| Invocation and Access Rules                                               | 2,183 |
| Syntax Rules and Parameters                                               | 2,183 |
| Description                                                               | 2,184 |
| Examples                                                                  | 2,184 |
| Compatibility                                                             | 2,185 |
| For More Information                                                      | 2,185 |
| 18.57 ALTER TABLE name REBALANCE                                          | 2,186 |
| Function                                                                  | 2,186 |
| Syntax                                                                    | 2,186 |
| Invocation and Access Rules                                               | 2,186 |
| Syntax Rules and Parameters                                               | 2,186 |
| Description                                                               | 2,187 |
| Examples                                                                  | 2,187 |
| Compatibility                                                             | 2,187 |
| 18.58 ALTER TABLE name REBALANCE EXCLUDE CLUSTER GROUP cluster_group_list | 2,188 |
| Function                                                                  | 2,188 |
| Syntax                                                                    | 2,188 |
| Invocation and Access Rules                                               | 2,188 |
| Syntax Rules and Parameters                                               | 2,188 |
| Description                                                               | 2,189 |
| Examples                                                                  | 2,189 |
| Compatibility                                                             | 2,190 |
| 18.59 ALTER TABLE name REBUILD GLOBAL SECONDARY INDEX                     | 2,191 |
| Function                                                                  | 2,191 |
| Syntax                                                                    | 2,191 |
| Invocation and Access Rules                                               | 2,192 |
| Syntax Rules and Parameters                                               | 2,192 |
| Description                                                               | 2,195 |
| Examples                                                                  | 2,195 |

|                                          |       |
|------------------------------------------|-------|
| Compatibility                            | 2,196 |
| For More Information                     | 2,196 |
| 18.60 ALTER TABLE name RENAME COLUMN     | 2,197 |
| Function                                 | 2,197 |
| Syntax                                   | 2,197 |
| Invocation and Access Rules              | 2,197 |
| Syntax Rules and Parameters              | 2,197 |
| Description                              | 2,198 |
| Example                                  | 2,198 |
| Compatibility                            | 2,198 |
| For More Information                     | 2,198 |
| 18.61 ALTER TABLE name RENAME CONSTRAINT | 2,199 |
| Function                                 | 2,199 |
| Syntax                                   | 2,199 |
| Invocation and Access Rules              | 2,199 |
| Syntax Rules and Parameters              | 2,199 |
| Description                              | 2,200 |
| Examples                                 | 2,200 |
| Compatibility                            | 2,200 |
| For More Information                     | 2,201 |
| 18.62 ALTER TABLE name RENAME SHARD      | 2,202 |
| Function                                 | 2,202 |
| Syntax                                   | 2,202 |
| Invocation and Access Rules              | 2,202 |
| Syntax Rules and Parameters              | 2,202 |
| Description                              | 2,203 |
| Examples                                 | 2,203 |
| Compatibility                            | 2,203 |
| For More Information                     | 2,204 |
| 18.63 ALTER TABLE name RENAME TO         | 2,205 |
| Function                                 | 2,205 |
| Syntax                                   | 2,205 |
| Invocation and Access Rules              | 2,205 |
| Syntax Rules and Parameters              | 2,205 |
| Description                              | 2,206 |
| Example                                  | 2,206 |
| Compatibility                            | 2,206 |
| For More Information                     | 2,206 |
| 18.64 ALTER TABLE name SET UNUSED COLUMN | 2,207 |

|                                                         |       |
|---------------------------------------------------------|-------|
| Function .....                                          | 2,207 |
| Syntax .....                                            | 2,207 |
| Invocation and Access Rules .....                       | 2,207 |
| Syntax Rules and Parameters .....                       | 2,207 |
| Description .....                                       | 2,208 |
| Example .....                                           | 2,208 |
| Compatibility .....                                     | 2,209 |
| For More Information .....                              | 2,209 |
| 18.65 ALTER TABLE name SPLIT SHARD .....                | 2,210 |
| Function .....                                          | 2,210 |
| Syntax .....                                            | 2,210 |
| Invocation and Access Rules .....                       | 2,210 |
| Syntax Rules and Parameters .....                       | 2,211 |
| Description .....                                       | 2,212 |
| Examples .....                                          | 2,213 |
| Compatibility .....                                     | 2,213 |
| For More Information .....                              | 2,213 |
| 18.66 ALTER TABLE name STORAGE .....                    | 2,214 |
| Function .....                                          | 2,214 |
| Syntax .....                                            | 2,214 |
| Invocation and Access Rules .....                       | 2,214 |
| Syntax Rules and Parameters .....                       | 2,215 |
| Description .....                                       | 2,215 |
| Example .....                                           | 2,215 |
| Compatibility .....                                     | 2,216 |
| For More Information .....                              | 2,216 |
| 18.67 ALTER TABLESPACE .....                            | 2,217 |
| Function .....                                          | 2,217 |
| Syntax .....                                            | 2,217 |
| Invocation and Access Rules .....                       | 2,217 |
| Syntax Rules and Parameters .....                       | 2,217 |
| Description .....                                       | 2,218 |
| Example .....                                           | 2,218 |
| Compatibility .....                                     | 2,218 |
| For More Information .....                              | 2,219 |
| 18.68 ALTER TABLESPACE name ADD [DATAFILE MEMORY] ..... | 2,220 |
| Function .....                                          | 2,220 |
| Syntax .....                                            | 2,220 |
| Invocation and Access Rules .....                       | 2,221 |

|                                                    |       |
|----------------------------------------------------|-------|
| Syntax Rules and Parameters                        | 2,221 |
| Description                                        | 2,223 |
| Example                                            | 2,223 |
| Compatibility                                      | 2,223 |
| For More Information                               | 2,223 |
| 18.69 ALTER TABLESPACE name BACKUP                 | 2,224 |
| Function                                           | 2,224 |
| Syntax                                             | 2,224 |
| Invocation and Access Rules                        | 2,224 |
| Syntax Rules and Parameters                        | 2,224 |
| Description                                        | 2,226 |
| Examples                                           | 2,226 |
| Compatibility                                      | 2,226 |
| For More Information                               | 2,226 |
| 18.70 ALTER TABLESPACE name DROP [DATAFILE MEMORY] | 2,227 |
| Function                                           | 2,227 |
| Syntax                                             | 2,227 |
| Invocation and Access Rules                        | 2,227 |
| Syntax Rules and Parameters                        | 2,227 |
| Description                                        | 2,228 |
| Example                                            | 2,228 |
| Compatibility                                      | 2,228 |
| For More Information                               | 2,228 |
| 18.71 ALTER TABLESPACE name [ONLINE OFFLINE]       | 2,229 |
| Function                                           | 2,229 |
| Syntax                                             | 2,229 |
| Invocation and Access Rules                        | 2,229 |
| Syntax Rules and Parameters                        | 2,229 |
| Description                                        | 2,230 |
| Examples                                           | 2,230 |
| Compatibility                                      | 2,231 |
| For More Information                               | 2,231 |
| 18.72 ALTER TABLESPACE name RENAME DATAFILE        | 2,232 |
| Function                                           | 2,232 |
| Syntax                                             | 2,232 |
| Invocation and Access Rules                        | 2,232 |
| Syntax Rules and Parameters                        | 2,232 |
| Description                                        | 2,233 |
| Example                                            | 2,233 |

|                                       |       |
|---------------------------------------|-------|
| Compatibility                         | 2,233 |
| For More Information                  | 2,233 |
| 18.73 ALTER TABLESPACE name RENAME TO | 2,234 |
| Function                              | 2,234 |
| Syntax                                | 2,234 |
| Invocation and Access Rules           | 2,234 |
| Syntax Rules and Parameters           | 2,234 |
| Description                           | 2,235 |
| Example                               | 2,235 |
| Compatibility                         | 2,235 |
| For More Information                  | 2,235 |
| 18.74 ALTER USER                      | 2,236 |
| Function                              | 2,236 |
| Syntax                                | 2,236 |
| Invocation and Access Rules           | 2,237 |
| Syntax Rules and Parameters           | 2,237 |
| Description                           | 2,240 |
| Examples                              | 2,240 |
| Compatibility                         | 2,241 |
| For More Information                  | 2,242 |
| 18.75 ALTER VIEW                      | 2,243 |
| Function                              | 2,243 |
| Syntax                                | 2,243 |
| Invocation and Access Rules           | 2,243 |
| Syntax Rules and Parameters           | 2,243 |
| Description                           | 2,244 |
| Example                               | 2,244 |
| Compatibility                         | 2,245 |
| For More Information                  | 2,245 |
| 18.76 ANALYZE SYSTEM                  | 2,246 |
| Function                              | 2,246 |
| Syntax                                | 2,246 |
| Invocation and Access Rules           | 2,246 |
| Syntax Rules and Parameters           | 2,246 |
| Description                           | 2,247 |
| Examples                              | 2,247 |
| Compatibility                         | 2,247 |
| For More Information                  | 2,248 |
| 18.77 ANALYZE TABLE                   | 2,249 |

|                                 |              |
|---------------------------------|--------------|
| Function                        | 2,249        |
| Syntax                          | 2,249        |
| Invocation and Access Rules     | 2,249        |
| Syntax Rules and Parameters     | 2,250        |
| Description                     | 2,253        |
| Examples                        | 2,253        |
| Compatibility                   | 2,255        |
| For More Information            | 2,255        |
| <b>18.78 AUDIT POLICY</b>       | <b>2,256</b> |
| Function                        | 2,256        |
| Syntax                          | 2,256        |
| Invocation and Access Rules     | 2,256        |
| Syntax Rules and Parameters     | 2,256        |
| Description                     | 2,257        |
| Examples                        | 2,260        |
| Compatibility                   | 2,261        |
| For More Information            | 2,261        |
| <b>19. SQL References (C~G)</b> | <b>2,263</b> |
| <b>19.1 CLOSE cursor_name</b>   | <b>2,264</b> |
| Function                        | 2,264        |
| Syntax                          | 2,264        |
| Syntax Rules and Parameters     | 2,264        |
| Description                     | 2,264        |
| Example                         | 2,264        |
| Compatibility                   | 2,265        |
| For More Information            | 2,265        |
| <b>19.2 COMMENT ON name IS</b>  | <b>2,266</b> |
| Function                        | 2,266        |
| Syntax                          | 2,266        |
| Invocation and Access Rules     | 2,266        |
| Syntax Rules and Parameters     | 2,268        |
| Description                     | 2,269        |
| Examples                        | 2,270        |
| Compatibility                   | 2,271        |
| <b>19.3 COMMIT</b>              | <b>2,272</b> |
| Function                        | 2,272        |
| Syntax                          | 2,272        |
| Syntax Rules and Parameters     | 2,272        |
| Description                     | 2,273        |



|                                        |       |
|----------------------------------------|-------|
| Example .....                          | 2,274 |
| Compatibility .....                    | 2,274 |
| For More Information .....             | 2,274 |
| 19.4 CREATE AUDIT POLICY .....         | 2,275 |
| Function .....                         | 2,275 |
| Syntax .....                           | 2,275 |
| Invocation and Access Rules .....      | 2,275 |
| Syntax Rules and Parameters .....      | 2,276 |
| Description .....                      | 2,278 |
| Examples .....                         | 2,280 |
| Compatibility .....                    | 2,281 |
| For More Information .....             | 2,281 |
| 19.5 CREATE CLUSTER GROUP .....        | 2,282 |
| Function .....                         | 2,282 |
| Syntax .....                           | 2,282 |
| Invocation and Access Rules .....      | 2,282 |
| Syntax Rules and Parameters .....      | 2,282 |
| Description .....                      | 2,284 |
| Examples .....                         | 2,284 |
| Compatibility .....                    | 2,285 |
| For More Information .....             | 2,285 |
| 19.6 CREATE CLUSTER LOCATION .....     | 2,286 |
| Function .....                         | 2,286 |
| Syntax .....                           | 2,286 |
| Invocation and Access Rules .....      | 2,286 |
| Syntax Rules and Parameters .....      | 2,286 |
| Description .....                      | 2,287 |
| Examples .....                         | 2,287 |
| Compatibility .....                    | 2,287 |
| For More Information .....             | 2,287 |
| 19.7 CREATE DISK DATA TABLESPACE ..... | 2,288 |
| Function .....                         | 2,288 |
| Syntax .....                           | 2,288 |
| Invocation and Access Rules .....      | 2,288 |
| Syntax Rules and Parameters .....      | 2,289 |
| Description .....                      | 2,291 |
| Examples .....                         | 2,291 |
| Compatibility .....                    | 2,291 |
| For More Information .....             | 2,291 |

|       |                                    |       |
|-------|------------------------------------|-------|
| 19.8  | CREATE GLOBAL TEMPORARY TABLE      | 2,292 |
|       | Function                           | 2,292 |
|       | Syntax                             | 2,292 |
|       | Invocation and Access Rules        | 2,292 |
|       | Syntax Rules and Parameters        | 2,293 |
|       | Description                        | 2,293 |
|       | Examples                           | 2,294 |
|       | Compatibility                      | 2,295 |
|       | For More Information               | 2,296 |
| 19.9  | CREATE IMMUTABLE TABLE             | 2,297 |
|       | Function                           | 2,297 |
|       | Syntax                             | 2,297 |
|       | Invocation and Access Rules        | 2,297 |
|       | Syntax Rules and Parameters        | 2,298 |
|       | Description                        | 2,298 |
|       | Examples                           | 2,299 |
|       | Compatibility                      | 2,300 |
|       | For More Information               | 2,300 |
| 19.10 | CREATE INDEX                       | 2,301 |
|       | Function                           | 2,301 |
|       | Syntax                             | 2,301 |
|       | Invocation and Access Rules        | 2,302 |
|       | Syntax Rules and Parameters        | 2,302 |
|       | Description                        | 2,306 |
|       | Examples                           | 2,306 |
|       | Compatibility                      | 2,307 |
|       | For more information               | 2,308 |
| 19.11 | CREATE MEMORY DATA TABLESPACE      | 2,309 |
|       | Function                           | 2,309 |
|       | Syntax                             | 2,309 |
|       | Invocation and Access Rules        | 2,309 |
|       | Syntax Rules and Parameters        | 2,310 |
|       | Description                        | 2,311 |
|       | Examples                           | 2,312 |
|       | Compatibility                      | 2,312 |
|       | For More Information               | 2,312 |
| 19.12 | CREATE MEMORY TEMPORARY TABLESPACE | 2,313 |
|       | Function                           | 2,313 |
|       | Syntax                             | 2,313 |

|                             |       |
|-----------------------------|-------|
| Invocation and Access Rules | 2,313 |
| Syntax Rules and Parameters | 2,314 |
| Description                 | 2,315 |
| Examples                    | 2,315 |
| Compatibility               | 2,315 |
| For More Information        | 2,316 |
| 19.13 CREATE PROFILE        | 2,317 |
| Function                    | 2,317 |
| Syntax                      | 2,317 |
| Invocation and Access Rules | 2,317 |
| Syntax Rules and Parameters | 2,318 |
| Description                 | 2,322 |
| Examples                    | 2,326 |
| Compatibility               | 2,327 |
| For More Information        | 2,327 |
| 19.14 CREATE SCHEMA         | 2,328 |
| Function                    | 2,328 |
| Syntax                      | 2,328 |
| Invocation and Access Rules | 2,328 |
| Syntax Rules and Parameters | 2,329 |
| Description                 | 2,330 |
| Examples                    | 2,331 |
| Compatibility               | 2,331 |
| For More Information        | 2,332 |
| 19.15 CREATE SEQUENCE       | 2,333 |
| Function                    | 2,333 |
| Syntax                      | 2,333 |
| Invocation and Access Rules | 2,334 |
| Syntax Rules and Parameters | 2,334 |
| Description                 | 2,337 |
| Examples                    | 2,337 |
| Compatibility               | 2,338 |
| For More Information        | 2,338 |
| 19.16 CREATE SYNONYM        | 2,339 |
| Function                    | 2,339 |
| Syntax                      | 2,339 |
| Invocation and Access Rules | 2,339 |
| Syntax Rules and Parameters | 2,340 |
| Description                 | 2,341 |

|                              |       |
|------------------------------|-------|
| Examples                     | 2,341 |
| Compatibility                | 2,342 |
| For More Information         | 2,342 |
| 19.17 CREATE TABLE           | 2,343 |
| Function                     | 2,343 |
| Syntax                       | 2,343 |
| Invocation and Access Rules  | 2,348 |
| Syntax Rules and Parameters  | 2,349 |
| Description                  | 2,369 |
| Examples                     | 2,370 |
| Compatibility                | 2,376 |
| For More Information         | 2,377 |
| 19.18 CREATE TABLE AS SELECT | 2,378 |
| Function                     | 2,378 |
| Syntax                       | 2,378 |
| Invocation and Access Rules  | 2,380 |
| Syntax Rules and Parameters  | 2,380 |
| Description                  | 2,381 |
| Examples                     | 2,381 |
| Compatibility                | 2,383 |
| For More Information         | 2,384 |
| 19.19 CREATE TABLESPACE      | 2,385 |
| Function                     | 2,385 |
| Syntax                       | 2,385 |
| Invocation and Access Rules  | 2,385 |
| Syntax Rules and Parameters  | 2,385 |
| Description                  | 2,386 |
| Example                      | 2,386 |
| Compatibility                | 2,386 |
| For More Information         | 2,386 |
| 19.20 CREATE USER            | 2,387 |
| Function                     | 2,387 |
| Syntax                       | 2,387 |
| Invocation and Access Rules  | 2,387 |
| Syntax Rules and Parameters  | 2,388 |
| Description                  | 2,390 |
| Examples                     | 2,391 |
| Compatibility                | 2,393 |
| For More Information         | 2,393 |

|                                                |       |
|------------------------------------------------|-------|
| 19.21 CREATE VIEW .....                        | 2,394 |
| Function .....                                 | 2,394 |
| Syntax .....                                   | 2,394 |
| Invocation and Access Rules .....              | 2,394 |
| Syntax Rules and Parameters .....              | 2,395 |
| Description .....                              | 2,396 |
| Examples .....                                 | 2,397 |
| Compatibility .....                            | 2,398 |
| For More Information .....                     | 2,398 |
| 19.22 DECLARE cursor_name .....                | 2,399 |
| Function .....                                 | 2,399 |
| Syntax .....                                   | 2,399 |
| Invocation and Access Rules .....              | 2,400 |
| Syntax Rules and Parameters .....              | 2,400 |
| Description .....                              | 2,405 |
| Examples .....                                 | 2,406 |
| Compatibility .....                            | 2,410 |
| For More Information .....                     | 2,411 |
| 19.23 DELETE FROM .....                        | 2,412 |
| Function .....                                 | 2,412 |
| Syntax .....                                   | 2,412 |
| Invocation and Access Rules .....              | 2,412 |
| Syntax Rules and Parameters .....              | 2,413 |
| Description .....                              | 2,414 |
| Examples .....                                 | 2,414 |
| Compatibility .....                            | 2,415 |
| For More Information .....                     | 2,415 |
| 19.24 DELETE FROM name RETURNING .....         | 2,416 |
| Function .....                                 | 2,416 |
| Syntax .....                                   | 2,416 |
| Invocation and Access Rules .....              | 2,416 |
| Syntax Rules and Parameters .....              | 2,417 |
| Description .....                              | 2,418 |
| Examples .....                                 | 2,418 |
| Compatibility .....                            | 2,419 |
| For More Information .....                     | 2,419 |
| 19.25 DELETE FROM name RETURNING .. INTO ..... | 2,420 |
| Function .....                                 | 2,420 |
| Syntax .....                                   | 2,420 |

|                                                     |       |
|-----------------------------------------------------|-------|
| Invocation and Access Rules                         | 2,420 |
| Syntax Rules and Parameters                         | 2,421 |
| Description                                         | 2,422 |
| Example                                             | 2,422 |
| Compatibility                                       | 2,422 |
| For More Information                                | 2,423 |
| 19.26 DELETE FROM name WHERE CURRENT OF cursor_name | 2,424 |
| Function                                            | 2,424 |
| Syntax                                              | 2,424 |
| Invocation and Access Rules                         | 2,424 |
| Syntax Rules and Parameters                         | 2,424 |
| Description                                         | 2,425 |
| Example                                             | 2,425 |
| Compatibility                                       | 2,426 |
| For More Information                                | 2,426 |
| 19.27 DROP AUDIT POLICY                             | 2,428 |
| Function                                            | 2,428 |
| Syntax                                              | 2,428 |
| Invocation and Access Rules                         | 2,428 |
| Syntax Rules and Parameters                         | 2,428 |
| Description                                         | 2,428 |
| Examples                                            | 2,429 |
| Compatibility                                       | 2,429 |
| For More Information                                | 2,429 |
| 19.28 DROP CLUSTER GROUP                            | 2,430 |
| Function                                            | 2,430 |
| Syntax                                              | 2,430 |
| Invocation and Access Rules                         | 2,430 |
| Syntax Rules and Parameters                         | 2,430 |
| Description                                         | 2,430 |
| Examples                                            | 2,431 |
| Compatibility                                       | 2,431 |
| For More Information                                | 2,431 |
| 19.29 DROP CLUSTER LOCATION                         | 2,432 |
| Function                                            | 2,432 |
| Syntax                                              | 2,432 |
| Invocation and Access Rules                         | 2,432 |
| Syntax Rules and Parameters                         | 2,432 |
| Description                                         | 2,432 |

|                             |       |
|-----------------------------|-------|
| Example                     | 2,433 |
| Compatibility               | 2,433 |
| For More Information        | 2,433 |
| 19.30 DROP INDEX            | 2,434 |
| Function                    | 2,434 |
| Syntax                      | 2,434 |
| Invocation and Access Rules | 2,434 |
| Syntax Rules and Parameters | 2,434 |
| Description                 | 2,435 |
| Examples                    | 2,435 |
| Compatibility               | 2,435 |
| For More Information        | 2,435 |
| 19.31 DROP PROFILE          | 2,436 |
| Function                    | 2,436 |
| Syntax                      | 2,436 |
| Invocation and Access Rules | 2,436 |
| Syntax Rules and Parameters | 2,436 |
| Example                     | 2,437 |
| Compatibility               | 2,437 |
| For More Information        | 2,437 |
| 19.32 DROP SCHEMA           | 2,438 |
| Function                    | 2,438 |
| Syntax                      | 2,438 |
| Invocation and Access Rules | 2,438 |
| Syntax Rules and Parameters | 2,438 |
| Description                 | 2,439 |
| Examples                    | 2,439 |
| Compatibility               | 2,440 |
| For More Information        | 2,440 |
| 19.33 DROP SEQUENCE         | 2,441 |
| Function                    | 2,441 |
| Syntax                      | 2,441 |
| Invocation and Access Rules | 2,441 |
| Syntax Rules and Parameters | 2,441 |
| Description                 | 2,442 |
| Examples                    | 2,442 |
| Compatibility               | 2,442 |
| For More Information        | 2,442 |
| 19.34 DROP SYNONYM          | 2,444 |

|                             |       |
|-----------------------------|-------|
| Function                    | 2,444 |
| Syntax                      | 2,444 |
| Invocation and Access Rules | 2,444 |
| Syntax Rules and Parameters | 2,444 |
| Description                 | 2,445 |
| Examples                    | 2,445 |
| Compatibility               | 2,445 |
| For More Information        | 2,446 |
| 19.35 DROP TABLE            | 2,447 |
| Function                    | 2,447 |
| Syntax                      | 2,447 |
| Invocation and Access Rules | 2,447 |
| Syntax Rules and Parameters | 2,448 |
| Description                 | 2,448 |
| Examples                    | 2,449 |
| Compatibility               | 2,450 |
| For More Information        | 2,450 |
| 19.36 DROP TABLESPACE       | 2,451 |
| Function                    | 2,451 |
| Syntax                      | 2,451 |
| Invocation and Access Rules | 2,451 |
| Syntax Rules and Parameters | 2,451 |
| Description                 | 2,453 |
| Examples                    | 2,453 |
| Compatibility               | 2,453 |
| For More Information        | 2,453 |
| 19.37 DROP USER             | 2,454 |
| Function                    | 2,454 |
| Syntax                      | 2,454 |
| Invocation and Access Rules | 2,454 |
| Syntax Rules and Parameters | 2,454 |
| Description                 | 2,456 |
| Examples                    | 2,456 |
| Compatibility               | 2,456 |
| For More Information        | 2,457 |
| 19.38 DROP VIEW             | 2,458 |
| Function                    | 2,458 |
| Syntax                      | 2,458 |
| Invocation and Access Rules | 2,458 |



|                                      |       |
|--------------------------------------|-------|
| Syntax Rules and Parameters          | 2,458 |
| Description                          | 2,459 |
| Examples                             | 2,459 |
| Compatibility                        | 2,459 |
| For More Information                 | 2,459 |
| 19.39 EXECUTE IMMEDIATE 'sql_string' | 2,460 |
| Function                             | 2,460 |
| Syntax                               | 2,460 |
| Invocation and Access Rules          | 2,460 |
| Syntax Rules and Parameters          | 2,460 |
| Description                          | 2,461 |
| Example                              | 2,461 |
| Compatibility                        | 2,462 |
| For More Information                 | 2,462 |
| 19.40 EXECUTE statement_name         | 2,463 |
| Function                             | 2,463 |
| Syntax                               | 2,463 |
| Invocation and Access Rules          | 2,463 |
| Syntax Rules and Parameters          | 2,463 |
| Description                          | 2,466 |
| Example                              | 2,466 |
| Compatibility                        | 2,466 |
| For More Information                 | 2,467 |
| 19.41 FETCH cursor_name              | 2,468 |
| Function                             | 2,468 |
| Syntax                               | 2,468 |
| Syntax Rules and Parameters          | 2,468 |
| Description                          | 2,470 |
| Example                              | 2,470 |
| Compatibility                        | 2,473 |
| For More Information                 | 2,473 |
| 19.42 FLASHBACK TABLE                | 2,474 |
| Function                             | 2,474 |
| Syntax                               | 2,474 |
| Invocation and Access Rules          | 2,474 |
| Syntax Rules and Parameters          | 2,474 |
| Description                          | 2,475 |
| Example                              | 2,475 |
| Compatibility                        | 2,476 |

|                                               |              |
|-----------------------------------------------|--------------|
| For More Information .....                    | 2,476        |
| 19.43 GRANT privileges TO .....               | 2,477        |
| Function .....                                | 2,477        |
| Syntax .....                                  | 2,477        |
| Syntax Rules and Parameters .....             | 2,480        |
| Description .....                             | 2,486        |
| Examples .....                                | 2,487        |
| Compatibility .....                           | 2,488        |
| For More Information .....                    | 2,489        |
| <b>20. SQL References (H~Z) .....</b>         | <b>2,491</b> |
| 20.1 INSERT INTO .....                        | 2,492        |
| Function .....                                | 2,492        |
| Syntax .....                                  | 2,492        |
| Invocation and Access Rules .....             | 2,492        |
| Syntax Rules and Parameters .....             | 2,493        |
| Description .....                             | 2,494        |
| Examples .....                                | 2,494        |
| Compatibility .....                           | 2,496        |
| For More Information .....                    | 2,496        |
| 20.2 INSERT INTO name RETURNING .....         | 2,497        |
| Function .....                                | 2,497        |
| Syntax .....                                  | 2,497        |
| Invocation and Access Rules .....             | 2,497        |
| Syntax Rules and Parameters .....             | 2,498        |
| Description .....                             | 2,499        |
| Examples .....                                | 2,499        |
| Compatibility .....                           | 2,500        |
| For More Information .....                    | 2,500        |
| 20.3 INSERT INTO name RETURNING .. INTO ..... | 2,501        |
| Function .....                                | 2,501        |
| Syntax .....                                  | 2,501        |
| Invocation and Access Rules .....             | 2,501        |
| Syntax Rules and Parameters .....             | 2,502        |
| Description .....                             | 2,503        |
| Example .....                                 | 2,503        |
| Compatibility .....                           | 2,504        |
| For More Information .....                    | 2,504        |
| 20.4 INSERT INTO name ... UPDATE .....        | 2,505        |
| Function .....                                | 2,505        |

|                                                     |       |
|-----------------------------------------------------|-------|
| Syntax                                              | 2,505 |
| Invocation and Access Rules                         | 2,506 |
| Syntax Rules and Parameters                         | 2,506 |
| Description                                         | 2,509 |
| Examples                                            | 2,510 |
| Compatibility                                       | 2,511 |
| For More Information                                | 2,511 |
| 20.5 INSERT INTO name ... UPDATE RETURNING          | 2,512 |
| Function                                            | 2,512 |
| Syntax                                              | 2,512 |
| Invocation and Access Rules                         | 2,513 |
| Syntax Rules and Parameters                         | 2,513 |
| Description                                         | 2,515 |
| Compatibility                                       | 2,516 |
| For More Information                                | 2,516 |
| 20.6 INSERT INTO name ... UPDATE RETURNING ... INTO | 2,517 |
| Function                                            | 2,517 |
| Syntax                                              | 2,517 |
| Invocation and Access Rules                         | 2,518 |
| Syntax Rules and Parameters                         | 2,518 |
| Description                                         | 2,520 |
| Compatibility                                       | 2,521 |
| For More Information                                | 2,521 |
| 20.7 LOCK TABLE                                     | 2,522 |
| Function                                            | 2,522 |
| Syntax                                              | 2,522 |
| Invocation and Access Rules                         | 2,522 |
| Syntax Rules and Parameters                         | 2,523 |
| Description                                         | 2,524 |
| Examples                                            | 2,524 |
| Compatibility                                       | 2,524 |
| For More Information                                | 2,525 |
| 20.8 NOAUDIT POLICY                                 | 2,526 |
| Function                                            | 2,526 |
| Syntax                                              | 2,526 |
| Invocation and Access Rules                         | 2,526 |
| Syntax Rules and Parameters                         | 2,526 |
| Description                                         | 2,527 |
| Examples                                            | 2,530 |

|                                                   |       |
|---------------------------------------------------|-------|
| Compatibility .....                               | 2,530 |
| For More Information .....                        | 2,530 |
| 20.9 OPEN cursor_name .....                       | 2,532 |
| Function .....                                    | 2,532 |
| Syntax .....                                      | 2,532 |
| Invocation and Access Rules .....                 | 2,532 |
| Syntax Rules and Parameters .....                 | 2,532 |
| Description .....                                 | 2,533 |
| Examples .....                                    | 2,534 |
| Compatibility .....                               | 2,535 |
| For More Information .....                        | 2,535 |
| 20.10 PREPARE statement_name .....                | 2,536 |
| Function .....                                    | 2,536 |
| Syntax .....                                      | 2,536 |
| Invocation and Access Rules .....                 | 2,536 |
| Syntax Rules and Parameters .....                 | 2,536 |
| Description .....                                 | 2,539 |
| Example .....                                     | 2,539 |
| Compatibility .....                               | 2,540 |
| For More Information .....                        | 2,540 |
| 20.11 PURGE .....                                 | 2,541 |
| Function .....                                    | 2,541 |
| Syntax .....                                      | 2,541 |
| Invocation and Access Rules .....                 | 2,541 |
| Syntax Rules and Parameters .....                 | 2,541 |
| Description .....                                 | 2,543 |
| Example .....                                     | 2,543 |
| Compatibility .....                               | 2,545 |
| For More Information .....                        | 2,545 |
| 20.12 RELEASE SAVEPOINT savepoint_specifier ..... | 2,546 |
| Function .....                                    | 2,546 |
| Syntax .....                                      | 2,546 |
| Syntax Rules and Parameters .....                 | 2,546 |
| Description .....                                 | 2,546 |
| Example .....                                     | 2,546 |
| Compatibility .....                               | 2,547 |
| For More Information .....                        | 2,547 |
| 20.13 REVOKE privileges FROM .....                | 2,548 |
| Function .....                                    | 2,548 |

|                                     |       |
|-------------------------------------|-------|
| Syntax                              | 2,548 |
| Syntax Rules and Parameters         | 2,548 |
| Description                         | 2,549 |
| Examples                            | 2,550 |
| Compatibility                       | 2,551 |
| For More Information                | 2,551 |
| 20.14 ROLLBACK                      | 2,552 |
| Function                            | 2,552 |
| Syntax                              | 2,552 |
| Syntax Rules and Parameters         | 2,552 |
| Description                         | 2,553 |
| Examples                            | 2,553 |
| Compatibility                       | 2,554 |
| For More Information                | 2,555 |
| 20.15 SAVEPOINT savepoint_specifier | 2,556 |
| Function                            | 2,556 |
| Syntax                              | 2,556 |
| Syntax Rules and Parameters         | 2,556 |
| Description                         | 2,556 |
| Example                             | 2,557 |
| Compatibility                       | 2,558 |
| For More Information                | 2,558 |
| 20.16 SELECT                        | 2,559 |
| query expression                    | 2,559 |
| with clause                         | 2,564 |
| query specification                 | 2,581 |
| select list                         | 2,587 |
| from clause                         | 2,591 |
| joined table                        | 2,599 |
| where clause                        | 2,610 |
| hierarchical query clause           | 2,612 |
| group by clause                     | 2,623 |
| having clause                       | 2,627 |
| order by clause                     | 2,629 |
| offset limit clause                 | 2,636 |
| set operator                        | 2,642 |
| subquery                            | 2,648 |
| hint clause                         | 2,652 |
| 20.17 SELECT .. FOR UPDATE          | 2,653 |

|                                    |       |
|------------------------------------|-------|
| Function                           | 2,653 |
| Syntax                             | 2,653 |
| Invocation and Access Rules        | 2,653 |
| Syntax Rules and Parameters        | 2,654 |
| Description                        | 2,655 |
| Examples                           | 2,656 |
| Compatibility                      | 2,657 |
| 20.18 SELECT .. INTO               | 2,658 |
| Function                           | 2,658 |
| Syntax                             | 2,658 |
| Invocation and Access Rules        | 2,658 |
| Syntax Rules and Parameters        | 2,658 |
| Description                        | 2,659 |
| Example                            | 2,660 |
| 20.19 SELECT .. INTO .. FOR UPDATE | 2,661 |
| Function                           | 2,661 |
| Syntax                             | 2,661 |
| Invocation and Access Rules        | 2,661 |
| Syntax Rules and Parameters        | 2,662 |
| Description                        | 2,664 |
| Examples                           | 2,665 |
| For More Information               | 2,666 |
| 20.20 SET CONSTRAINTS              | 2,667 |
| Function                           | 2,667 |
| Syntax                             | 2,667 |
| Invocation and Access Rules        | 2,667 |
| Syntax Rules and Parameters        | 2,667 |
| Description                        | 2,668 |
| Examples                           | 2,675 |
| Compatibility                      | 2,675 |
| For More Information               | 2,675 |
| 20.21 SET SCHEMA schema_name       | 2,676 |
| Function                           | 2,676 |
| Syntax                             | 2,676 |
| Invocation and Access Rules        | 2,676 |
| Syntax Rules and Parameters        | 2,676 |
| Description                        | 2,676 |
| Examples                           | 2,677 |
| Compatibility                      | 2,678 |

|                                                             |       |
|-------------------------------------------------------------|-------|
| 20.22 SET SESSION AUTHORIZATION user_identifier .....       | 2,679 |
| Function .....                                              | 2,679 |
| Syntax .....                                                | 2,679 |
| Invocation and Access Rules .....                           | 2,679 |
| Syntax Rules and Parameters .....                           | 2,680 |
| Description .....                                           | 2,680 |
| Example .....                                               | 2,680 |
| Compatibility .....                                         | 2,680 |
| 20.23 SET SESSION CHARACTERISTICS AS transaction_mode ..... | 2,681 |
| Function .....                                              | 2,681 |
| Syntax .....                                                | 2,681 |
| Syntax Rules and Parameters .....                           | 2,681 |
| Description .....                                           | 2,682 |
| Examples .....                                              | 2,682 |
| Compatibility .....                                         | 2,682 |
| For More Information .....                                  | 2,682 |
| 20.24 SET TIME ZONE .....                                   | 2,683 |
| Function .....                                              | 2,683 |
| Syntax .....                                                | 2,683 |
| Syntax Rules and Parameters .....                           | 2,683 |
| Description .....                                           | 2,683 |
| Example .....                                               | 2,684 |
| Compatibility .....                                         | 2,684 |
| 20.25 SET TRANSACTION transaction_mode .....                | 2,685 |
| Function .....                                              | 2,685 |
| Syntax .....                                                | 2,685 |
| Syntax Rules and Parameters .....                           | 2,685 |
| Description .....                                           | 2,686 |
| Example .....                                               | 2,686 |
| Compatibility .....                                         | 2,686 |
| For More Information .....                                  | 2,686 |
| 20.26 TRUNCATE TABLE .....                                  | 2,687 |
| Function .....                                              | 2,687 |
| Syntax .....                                                | 2,687 |
| Invocation and Access Rules .....                           | 2,687 |
| Syntax Rules and Parameters .....                           | 2,687 |
| Description .....                                           | 2,688 |
| Examples .....                                              | 2,688 |
| Compatibility .....                                         | 2,689 |

|                                                |       |
|------------------------------------------------|-------|
| 20.27 UPDATE                                   | 2,690 |
| Function                                       | 2,690 |
| Syntax                                         | 2,690 |
| Invocation and Access Rules                    | 2,690 |
| Syntax Rules and Parameters                    | 2,691 |
| Description                                    | 2,692 |
| Examples                                       | 2,693 |
| Compatibility                                  | 2,694 |
| 20.28 UPDATE name RETURNING                    | 2,695 |
| Function                                       | 2,695 |
| Syntax                                         | 2,695 |
| Invocation and Access Rules                    | 2,696 |
| Syntax Rules and Parameters                    | 2,696 |
| Description                                    | 2,697 |
| Examples                                       | 2,698 |
| Compatibility                                  | 2,698 |
| 20.29 UPDATE name RETURNING .. INTO            | 2,699 |
| Function                                       | 2,699 |
| Syntax                                         | 2,699 |
| Invocation and Access Rules                    | 2,700 |
| Syntax Rules and Parameters                    | 2,700 |
| Description                                    | 2,701 |
| Example                                        | 2,701 |
| Compatibility                                  | 2,702 |
| 20.30 UPDATE name WHERE CURRENT OF cursor_name | 2,703 |
| Function                                       | 2,703 |
| Syntax                                         | 2,703 |
| Invocation and Access Rules                    | 2,703 |
| Syntax Rules and Parameters                    | 2,703 |
| Description                                    | 2,704 |
| Examples                                       | 2,704 |
| Compatibility                                  | 2,706 |
| For More Information                           | 2,706 |



**11.**

---

## **SQL Elements**

## 11.1 Syntax Elements

### Identifiers

Identifier is divided into an ordinary identifier and a delimited identifier.

An ordinary identifier consists of letters or a combination of letters and numbers, and it is used by internally substituting all characters to uppercase letters. Therefore, an ordinary identifier is not case-sensitive.

The following is an example of an ordinary identifier.

```
GOLDILOCKS  
GoldiLocks
```

A delimited identifier consists of letters or a combination of letters and numbers enclosed in double quotes ("). All the characters are used as internally described. Therefore, a delimited identifier is case-sensitive.

The following is an example of a delimited identifier.

```
"GOLDILOCKS"  
"GoldiLocks"
```

### Literals

Literals mean representation of non-null value.

#### Text Literals

Text literals mean representation of strings and binary strings.

Use single quote (') at the beginning and end of a string to write string of text literals.

Not only the double quotes (") string but also all strings except for the single quote (') string can be written within a single quote (').

Use a single quote twice without white spaces in between to write a single quote (') in a string.

A maximum of 4000 characters can be written in a string.

The followings are examples of text literals for a string.

```
'GOLDILOCKS'  
'Sunje' 's DBMS'
```

A binary string of text literals is a string of hexadecimal numbers which starts with x'(X') and ends with '. Only the characters corresponding to 0 ~ 9, A (a) ~ F (f) can be written in each position of a hexadecimal string. The length of a hexadecimal string should always be an even number because its two digits mean one byte. A maximum of 4,000 characters can be written in a binary string.

The followings are examples of text literals for a binary string.

```
x'001f'  
X'FF0A'  
x'aF37BBc013'
```

## Numeric Literals

Numeric literals mean literals of numeric type, and integers or the number with decimal point can be written. The syntax for numeric literals is as follows.

```
[ + | - ] <digits> [ . <digits> ] [ E | e [ + | - ] <digits> ] [ f | F | d | D ]
```

- The first +/- means a positive or negative value of the entire number, and it can be omitted. If omitted, the default value is a positive value.
- In <digits>, numbers from 0 to 9 can be listed without white space, the number with decimal point can be written by using decimal point (.).
- An exponent form can be written after the first <digits>, and E or e is written, and it stands for exponent. Then +/- is written according to exponent sign, and <digits> is written. +/- of exponent can be omitted. If omitted, the default value is a positive value.
- Lastly, character such as f, F, d, D can be written after numbers. It means that it is a number of BINARY\_FLOAT, BINARY\_DOUBLE. If the corresponding character is omitted, the number is considered as NUMBER type.

The followings are examples of numeric literals.

```
20  
+123.45  
0.03  
+1.23E-02  
-1.5  
10f  
+123.45F  
1.2E-3F  
-22d
```

123.45D

-1.23E+05D

## Datetime Literals

Datetime literals are representation of date/time type.

Datetime value is specified using string literal, or by converting character or numeric value to datetime value using TO\_\*function (TO\_DATE, etc).

Datetime data types are DATE, TIME, TIME WITH TIME ZONE, TIMESTAMP, TIMESTAMP WITH TIME ZONE.

## Date Literals

Date literals are written in a form of DATE'string literal' or TO\_DATE(string\_literal [, format]).

- DATE'string literal'
  - The format of date type is ' SYYYY-MM-DD'.
  - DATE'2002-07-15'
- TO\_DATE(string\_literal [, format])
  - If the format is not specified, the format of date type is NLS\_DATE\_FORMAT by default.
  - If the format is specified, the specified format is applied.
- The date type includes year, month, day, hour, minute, second (except for fractional seconds).
- If the date is omitted, the default value is the first day of the current month.
- If the hour, minute, second are omitted, the default value is midnight.
  - HH24 format: '00:00:00'
  - HH12 format: '12:00:00'
- To set the hour, minute, second to the default value (midnight) when the date value includes hour, minute, second, then use the TRUNC(date) function.
- For example, in TRUNC(SYSDATE), SYSDATE includes the values of the year, month, day, hour, minute, second.
- To compare only the values of the year, month, day among date values, then set the values of the hour, minute, second are set to midnight using the TRUNC function.

For more information, refer to **TO\_DATE**, **Datetime Format String**, **NLS\_DATE\_FORMAT**.

- The following is an example of date literals.

```
DATE '2002-07-15'
```

- The following is an example of when the format is not specified, so NLS\_DATE\_FORMAT is 'YYYY-MM-DD'.

```
TO_DATE( '2002-07-15' )
```

- The followings are examples of when the format is specified.

```
TO_DATE( '15-JUL-02', 'DD-MON-RR' )
TO_DATE( '2002-07-15 00:00:00', 'YYYY-MM-DD HH24:MI:SS' )
TO_DATE( '2002-07-15 13:25:30', 'YYYY-MM-DD HH24:MI:SS' )
```

- The following is an example of when the date is omitted. (It is set to the first day of the current month).

```
gSQL> SELECT TO_DATE( '2000-07', 'YYYY-MM' ) FROM DUAL;
TO_DATE( '2000-07', 'YYYY-MM' )
-----
2000-07-01
```

- The following is an example of when the hour, minute, second are omitted. (It is set to the midnight).

```
gSQL> SELECT
      TO_CHAR( DATE'2002-07-15', 'YYYY-MM-DD HH24:MI:SS' ) AS RESULT
      FROM DUAL;
RESULT
-----
2002-07-15 00:00:00
```

- The following is an example of setting the hour, minute, second of DATE value (SYSDATE) to the default value (midnight).

```
gSQL> SELECT
      TO_CHAR( SYSDATE,
              'YYYY-MM-DD HH24:MI:SS' ) AS RESULT_SYSDATE,
      TO_CHAR( TRUNC( SYSDATE ),
              'YYYY-MM-DD HH24:MI:SS' ) AS RESULT_TRUNC_SYSDATE
      FROM DUAL;
RESULT_SYSDATE      RESULT_TRUNC_SYSDATE
-----
2014-08-19 10:06:49 2014-08-19 00:00:00
```

- The following is an example of comparing only the values of the year, month, day among date values.

```
gSQL> SELECT
      TO_DATE( '2002-08-12' ) =
```

```

TRUNC( TO_DATE( '2002-08-12 23:59:59', 'YYYY-MM-DD HH24:MI:SS' ) )
AS RESULT FROM DUAL;

RESULT
-----
TRUE

```

## Time Literals

Time literals are written in a form of `TIME'string literal'` or `TO_TIME(string_literal [, format])`.

- `TIME'string literal'`
  - The format of time type is `'HH24:MI:SS[.FF6]'`.
  - `TIME'15:30:59.999999'`
- `TO_TIME(string_literal [, format])`
  - If the format is not specified, the format of time type is `NLS_TIME_FORMAT` by default.
  - If the format is specified, the specified format is applied.

The time type includes hour, minute, second (fractional seconds).

Fractional seconds can be specified to maximum six digits numbers format.

For more information, refer to [TO\\_TIME](#), [Datetime Format String](#), [NLS\\_TIME\\_FORMAT](#).

- The following is an example of time literals.

```
TIME'15:30:59.999999'
```

- The following is an example of when the format is not specified, so `NLS_TIME_FORMAT` is `'HH24:MI:SS.FF6'`.

```
TO_TIME( '15:30:59.999999' )
```

- The following is an example of when the format is specified.

```
TO_TIME( '09.45.03.546873 AM', 'HH12.MI.SS.FF6 AM' )
TO_TIME( '09:45:03', 'HH12:MI:SS' )
```

## Time with Time Zone Literals

Time with time zone literals is written in a form of `TIME'string literal'`, `TIME WITH TIME ZONE'string literal'`, `TO_TIME_WITH_TIME_ZONE(string_literal [, format] )`, or `TO_TIME_TZ(string_literal [, format] )`.

- `TIME'string literal'` or `TIME WITH TIME ZONE'string literal'`
  - The format of time with time zone type is `'HH24:MI:SS[.FF6] TZh:TzM'`.

- `TIME'15:30:59.999999 +09:00'`
- `TIME WITH TIME ZONE'15:30:59.999999 +09:00'`
- `TO_TIME_WITH_TIME_ZONE(string_literal [, format] )`
  - If the format is not specified, the format of time with time zone type is `NLS_TIME_WITH_TIME_ZONE_FORMAT` by default.
  - If the format is specified, the specified format is applied.

Time with time zone type includes hour, minute, second (fractional seconds), and time zone offset (time zone hour, time zone minute).

Fractional seconds can be specified to maximum six digits numbers format.

For more information, refer to `TO_TIME_WITH_TIME_ZONE`, `Datetime Format String`, `NLS_TIME_WITH_TIME_ZONE_FORMAT`.

- The followings are examples of time with time zone literals.

```
TIME'15:30:59.999999 +09:00'
TIME WITH TIME ZONE'15:30:59.999999 +09:00'
```

- The following is an example of when the format is not specified, so `NLS_TIME_WITH_TIME_ZONE_FORMAT` is `'HH24:MI:SS.FF6 TZH:TZM'`.

```
TO_TIME_WITH_TIME_ZONE( '15:30:59.999999 +09:00' )
TO_TIME_TZ( '15:30:59.999999 +09:00' )
```

- The following is an example of when the format is specified.

```
TO_TIME_WITH_TIME_ZONE( '09.45.03.546873 +09:00 AM',
                        'HH12.MI.SS.FF6 TZH:TZM AM' )
```

## Timestamp Literals

Timestamp literals are written in a form of `TIMESTAMP'string literal'` or `TO_TIMESTAMP(string_literal [, format] )`.

- `TIMESTAMP'string literal'`
  - The format of timestamp type is `'YYYY-MM-DD HH24:MI:SS[. [FF6]]'`.
  - `TIMESTAMP'2002-07-15 15:39:59.999999'`
- `TO_TIMESTAMP(string_literal [, format] )`
  - If the format is not specified, the format of timestamp type is `NLS_TIMESTAMP_FORMAT` by default.
  - If the format is specified, the specified format is applied.

Timestamp type includes year, month, day, hour, minute, second (fractional seconds). Fractional seconds can be specified to maximum six digits numbers format.

For more information, refer to **TO\_TIMESTAMP**, **Datetime Format String**, **NLS\_TIMESTAMP\_FORMAT**.

- The following is an example of timestamp literals.

```
TIMESTAMP '2002-07-15 15:39:59.999999'
```

- The following is an example of when the format is not specified, so **NLS\_TIMESTAMP\_FORMAT** is 'YYYY-MM-DD HH24:MI:SS.FF6'.

```
TO_TIMESTAMP( '2002-07-15 15:39:59.999999' )
```

- The following is an example of when the format is specified.

```
TO_TIMESTAMP( '15-JUL-02 11.06.30.123456 AM',
              'DD-MON-RR HH12.MI.SS.FF6 AM' )
```

## Timestamp with Time Zone Literals

Timestamp with time zone literals is written in a form of **TIMESTAMP**'string literal', **TIMESTAMP WITH TIME\_ZONE**'string literal', **TO\_TIMESTAMP\_WITH\_TIME\_ZONE**(string\_literal [, format] ), or **TO\_TIMESTAMP\_TZ**(string\_literal [, format]).

- **TIMESTAMP**'string literal' or **TIMESTAMP WITH TIME\_ZONE**'string literal'
  - The format of timestamp with time zone type is 'SYYYY-MM-DD HH24:MI:SS[.FF6] TZH:TZM'.
  - **TIMESTAMP**'2002-07-15 15:39:59.999999 +09:00'
  - **TIMESTAMP WITH TIME\_ZONE**'2002-07-15 15:39:59.999999 +09:00'
- **TO\_TIMESTAMP\_WITH\_TIME\_ZONE**(string\_literal [, format] )
  - If the format is not specified, the format of timestamp with time zone type is **NLS\_TIMESTAMP\_WITH\_TIME\_ZONE\_FORMAT** by default.
  - If the format is specified, the specified format is applied.

Timestamp with time zone type includes year, month, day, hour, minute, second (fractional seconds), time zone offset (time zone hour, time zone minute).

Fractional seconds can be specified to maximum six digits numbers format.

For more information, refer to **TO\_TIMESTAMP\_WITH\_TIME\_ZONE**, **Datetime Format String** , **NLS\_TIMESTAMP\_WITH\_TIME\_ZONE\_FORMAT**.

- The following is an example of timestamp with time zone literals.



```
TIMESTAMP'2002-07-15 15:39:59.999999 +09:00'
```

```
TIMESTAMP WITH TIME ZONE'2002-07-15 15:39:59.999999 +09:00'
```

- The following is an example of when the format is not specified, so NLS\_TIMESTAMP\_WITH\_TIME\_ZONE\_FORMAT is 'YYYY-MM-DD HH24:MI:SS.FF6 TZH:TZM'.

```
TO_TIMESTAMP_WITH_TIME_ZONE( '2002-07-15 15:39:59.999999 +09:00' )
```

```
TO_TIMESTAMP_TZ( '2002-07-15 15:39:59.999999 +09:00' )
```

- The following is an example of when the format is specified.

```
TO_TIMESTAMP_WITH_TIME_ZONE( '15-JUL-02 11.06.30.123456 +09:00 AM',  
                              'DD-MON-RR HH12.MI.SS.FF6 TZH:TZM AM' )
```

```
TO_TIMESTAMP_TZ( '15-JUL-02 11.06.30.123456 +09:00 AM',  
                 'DD-MON-RR HH12.MI.SS.FF6 TZH:TZM AM' )
```

## Interval Literals

The interval literals specify the time interval.

Intervals are classified and expressed as follows.

- Year-month INTERVAL values
  - It includes YEAR and MONTH.
  - Display string expression: 'year-month'
  - It can be written in a form as *INTERVAL 'string literal' YEAR[leading precision] TO MONTH* or *NUMTOYMINTERVAL( num, interval\_indicator )*
- Day-time INTERVAL values
  - It includes DAY, HOUR, MINUTE, SECOND (fractional seconds).
  - Display string expression: 'day hour:minute:second.fractional\_seconds'
  - It can be written in a form as *INTERVAL 'string literal' DAY[leading precision] TO SECOND[fractional seconds precision]* or *NUMTODSINTERVAL( num, interval\_indicator )*.
- The interval value's sign is specified only once at the beginning of the string representation.  
e.g. INTERVAL'+3 11:22:33.999999'DAY TO SECOND (O)  
INTERVAL'-3 +11:22:33.999999'DAY TO SECOND (X)

The followings are the list of interval types.

- INTERVAL YEAR (leading precision)
- INTERVAL MONTH (leading precision)
- INTERVAL YEAR (leading precision) TO MONTH
- INTERVAL DAY (leading precision)

- INTERVAL HOUR (leading precision)
- INTERVAL MINUTE (leading precision)
- INTERVAL SECOND (leading precision[, fractional seconds precision] )
- INTERVAL DAY (leading precision) TO HOUR
- INTERVAL DAY (leading precision) TO MINUTE
- INTERVAL DAY (leading precision) TO SECOND (fractional seconds precision)
- INTERVAL HOUR (leading precision) TO MINUTE
- INTERVAL HOUR (leading precision) TO SECOND (fractional seconds precision)
- INTERVAL MINUTE (leading precision) TO SECOND (fractional seconds precision)

#### Leading precision

- It is the digit number of the field, it can be specified from 2 to 6. If it is not specified, the default value is set to 2.
- If the leading field value exceeds the leading precision, then an error is returned.

#### Fractional seconds precision

- It is the digit number of fractional seconds, and it can be specified from 0 to 6. If it is not specified, the default value is set to 6.
- If the fractional second field value exceeds the fractional seconds precision, then it is rounded off.

For more information, refer to **INTERVAL, Precisions and value range of the second or later field in INTERVAL \* TO \***, **NUMTODSINTERVAL**, **NUMTOYMINTERVAL**.

## Examples of Using Interval Literals.

The followings are examples of using interval literals.

### Interval YEAR

The followings are examples of using interval YEAR literals.

| Example                                | Description                                                  | Display string |
|----------------------------------------|--------------------------------------------------------------|----------------|
| INTERVAL'1'YEAR<br>INTERVAL'01-00'YEAR | 1 year                                                       | +01-00         |
| INTERVAL'100'YEAR                      | It exceeds the leading precision 2, so it returns the error. | -              |
| INTERVAL'100'YEAR(3)                   | 100 year                                                     | +100-00        |
| INTERVAL'+999999'YEAR(6)               | 999999 year                                                  | +999999-00     |
| INTERVAL'-999999'YEAR(6)               | -(999999 year)                                               | -999999-00     |

### Interval MONTH

The followings are examples of using interval MONTH literals.

| Example                                  | Description                                                  | Display string |
|------------------------------------------|--------------------------------------------------------------|----------------|
| INTERVAL'1'MONTH<br>INTERVAL'00-01'MONTH | 1 month                                                      | +00-01         |
| INTERVAL'100'MONTH                       | It exceeds the leading precision 2, so it returns the error. | -              |
| INTERVAL'100'MONTH(3)                    | 8 year 4 month                                               | +008-04        |
| INTERVAL'+999999'MONTH(6)                | 83333 year 3 month                                           | +083333-03     |
| INTERVAL'-999999'MONTH(6)                | -(83333 year 3 month)                                        | -083333-03     |

## Interval YEAR TO MONTH

The followings are examples of using interval YEAR TO MONTH literals.

| Example                              | Description                                                  | Display string |
|--------------------------------------|--------------------------------------------------------------|----------------|
| INTERVAL'1-06'YEAR TO MONTH          | 1 year 6 month                                               | +01-06         |
| INTERVAL'1-12'YEAR TO MONTH          | The month value exceeded 11, so it returns the error.        | -              |
| INTERVAL'100-11'YEAR TO MONTH        | It exceeds the leading precision 2, so it returns the error. | -              |
| INTERVAL'100-11'YEAR(3) TO MONTH     | 100 year 11 month                                            | +100-11        |
| INTERVAL'+999999-11'YEAR(6) TO MONTH | 999999 year 11 month                                         | +999999-11     |
| INTERVAL'-999999-11'YEAR(6) TO MONTH | -(999999 year 11 month)                                      | -999999-11     |

## Interval DAY

The followings are examples of using interval DAY literals.

| Example                                    | Description                                                  | Display string   |
|--------------------------------------------|--------------------------------------------------------------|------------------|
| INTERVAL'1'DAY<br>INTERVAL'01 00:00:00'DAY | 1 day                                                        | +01 00:00:00     |
| INTERVAL'100'DAY                           | It exceeds the leading precision 2, so it returns the error. | -                |
| INTERVAL'100'DAY(3)                        | 100 day                                                      | +100 00:00:00    |
| INTERVAL'+999999'DAY(6)                    | 999999 day                                                   | +999999 00:00:00 |
| INTERVAL'-999999'DAY(6)                    | -(999999 day)                                                | -999999 00:00:00 |

## Interval HOUR

The followings are examples of using interval HOUR literals.

| Example                                      | Description                                                 | Display string |
|----------------------------------------------|-------------------------------------------------------------|----------------|
| INTERVAL'1'HOUR<br>INTERVAL'00 01:00:00'HOUR | 1 hour                                                      | +00 01:00:00   |
| INTERVAL'1000'HOUR(3)                        | It exceeds the leading precision 3, so it returns the error | -              |

| Example                  | Description          | Display string   |
|--------------------------|----------------------|------------------|
| INTERVAL'1000'HOUR(4)    | 41 day 16 hour       | +0041 16:00:00   |
| INTERVAL'+999999'HOUR(6) | 41666 day 15 hour    | +041666 15:00:00 |
| INTERVAL'-999999'HOUR(6) | -(41666 day 15 hour) | -041666 15:00:00 |

## Interval MINUTE

The following are examples of using interval MINUTE literals.

| Example                                          | Description                                                 | Display string   |
|--------------------------------------------------|-------------------------------------------------------------|------------------|
| INTERVAL'1'MINUTE<br>INTERVAL'00 00:01:00'MINUTE | 1 minute                                                    | +00 00:01:00     |
| INTERVAL'12345'MINUTE(4)                         | It exceeds the leading precision 4, so it returns the error | -                |
| INTERVAL'12345'MINUTE(5)                         | 8 day 13 hour 45 minute                                     | +00008 13:45:00  |
| INTERVAL'+999999'MINUTE(6)                       | 694 day 10 hour 39 minute                                   | +000694 10:39:00 |
| INTERVAL'-999999'MINUTE(6)                       | -(694 day 10 hour 39 minute)                                | -000694 10:39:00 |

## Interval SECOND

The followings are examples of using interval SECOND literals.

| Example                                                       | Description                                                                                                                    | Display string          |
|---------------------------------------------------------------|--------------------------------------------------------------------------------------------------------------------------------|-------------------------|
| INTERVAL'1'SECOND<br>INTERVAL'00 00:00:01.000000'SECOND       | 1 second                                                                                                                       | +00 00:00:01.000000     |
| INTERVAL'100'SECOND                                           | It exceeds the leading precision 2, so it returns the error.                                                                   | -                       |
| INTERVAL'99.9999999'SECOND<br>INTERVAL'99.9999999'SECOND(2,6) | The fractional seconds are rounded off to become 100 second, then it exceeds the leading precision 2, so it returns the error. | -                       |
| INTERVAL'99.9999999'SECOND(3)                                 | 1 minute 40 second                                                                                                             | +000 00:01:40.000000    |
| INTERVAL'29.506167'SECOND(2, 2)                               | 29.51 second                                                                                                                   | +00 00:00:29.51         |
| INTERVAL'999999.999999'SECOND(6,6)                            | 11day 13 hour 46 minute 39.999999 second                                                                                       | +000011 13:46:39.999999 |
| INTERVAL'-999999.999999'SECOND(6,6)                           | -(11day 13 hour 46 minute 39.999999 second)                                                                                    | -000011 13:46:39.999999 |

## Interval DAY TO HOUR

The followings are examples of using interval DAY TO HOUR literals.

| Example                   | Description | Display string |
|---------------------------|-------------|----------------|
| INTERVAL'1 23'DAY TO HOUR |             |                |

| Example                             | Description                                                   | Display string   |
|-------------------------------------|---------------------------------------------------------------|------------------|
| INTERVAL'01 23:00:00'DAY TO HOUR    | 1 day 23 hour                                                 | +01 23:00:00     |
| INTERVAL'1 24'DAY TO HOUR           | The hour value exceeds 23 (invalid), so it returns the error. | -                |
| INTERVAL'100 23'DAY TO HOUR         | It exceeds the leading precision 2, so it returns the error.  | -                |
| INTERVAL'100 23'DAY(3) TO HOUR      | 100 day 23 hour                                               | +100 23:00:00    |
| INTERVAL'+999999 23'DAY(6) TO HOUR  | 999999 day 23 hour                                            | +999999 23:00:00 |
| INTERVAL'-999999 23'DAY(6) TO HOUR  | -(999999 day 23 hour)                                         | -999999 23:00:00 |
| INTERVAL'-999999 +23'DAY(6) TO HOUR | Invalid sign error                                            | -                |

## Interval DAY TO MINUTE

The followings are examples of using interval DAY TO MINUTE literals.

| Example                                                              | Description                                                     | Display string   |
|----------------------------------------------------------------------|-----------------------------------------------------------------|------------------|
| INTERVAL'1 23:59'DAY TO MINUTE<br>INTERVAL'01 23:59:00'DAY TO MINUTE | 1 day 23 hour 59 second                                         | +01 23:59:00     |
| INTERVAL'1 24:59'DAY TO MINUTE                                       | The hour value exceeds 23 (invalid), so it returns the error.   | -                |
| INTERVAL'1 23:60'DAY TO MINUTE                                       | The minute value exceeds 59 (invalid), so it returns the error. | -                |
| INTERVAL'100 23:59'DAY TO MINUTE                                     | It exceeds the leading precision 2, so it returns the error.    | -                |
| INTERVAL'100 23:59'DAY(3) TO MINUTE                                  | 100 day 23 hour 59 minute                                       | +100 23:59:00    |
| INTERVAL'+999999 23:59'DAY(6) TO MINUTE                              | 999999 day 23 hour 59 minute                                    | +999999 23:59:00 |
| INTERVAL'-999999 23:59'DAY(6) TO MINUTE                              | -(999999 day 23 hour 59 minute)                                 | -999999 23:59:00 |

## Interval DAY TO SECOND

The followings are examples of using interval DAY TO SECOND literals.

| Example                                   | Description                                           | display string      |
|-------------------------------------------|-------------------------------------------------------|---------------------|
| INTERVAL '1 23:59:59.999999'DAY TO SECOND | 1 day 23 hour 59 minute 59.999999 second              | +01 23:59:59.999999 |
| INTERVAL '1 24:59:59.999999'DAY TO SECOND | The hour value exceeds 23, so it returns the error.   | -                   |
| INTERVAL '1 23:60:59.999999'DAY TO SECOND | The minute value exceeds 59, so it returns the error. | -                   |
|                                           | The second value exceeds 60,                          |                     |

| Example                                               | Description                                                                                                                 | display string          |
|-------------------------------------------------------|-----------------------------------------------------------------------------------------------------------------------------|-------------------------|
| INTERVAL '1 23:59:60.999999'DAY TO SECOND             | so it returns the error.                                                                                                    | -                       |
| INTERVAL '99 23:59:59.999999'DAY TO SECOND            | The fractional seconds are rounded off to become 100 day, then it exceeds the leading precision 2, so it returns the error. | -                       |
| INTERVAL '99 23:59:59.999999'DAY(3) TO SECOND         | 100 day                                                                                                                     | +100 00:00:00.000000    |
| INTERVAL '1 11:22:33.567890'DAY(2) TO SECOND(2)       | 1 day 11 hour 22 minute 33.57 second                                                                                        | +01 11:22:33.57         |
| INTERVAL '+999999 23:59:59.999999'DAY(6) TO SECOND(6) | 999999 day 23 hour 59 minute 59.999999 hour                                                                                 | +999999 23:59:59.999999 |
| INTERVAL '-999999 23:59:59.999999'DAY(6) TO SECOND(6) | -(999999 day 23 hour 59 minute 59.999999 hour)                                                                              | -999999 23:59:59.999999 |

## Interval HOUR TO MINUTE

The followings are examples of using interval HOUR TO MINUTE literals.

| Example                                                                | Description                                                  | Display string   |
|------------------------------------------------------------------------|--------------------------------------------------------------|------------------|
| INTERVAL '23:59'HOUR TO MINUTE<br>INTERVAL '00 23:59:00'HOUR TO MINUTE | 23 hour 59 minute                                            | +00 23:59:00     |
| INTERVAL '23:60'HOUR TO MINUTE                                         | The minute value exceeds 59, so it returns the error.        | -                |
| INTERVAL '100:59'HOUR TO MINUTE                                        | It exceeds the leading precision 2, so it returns the error. | -                |
| INTERVAL '100:59'HOUR(3) TO MINUTE                                     | 4 day 4 hour 59 minute                                       | +004 04:59:00    |
| INTERVAL '+999999:59'HOUR(6) TO MINUTE                                 | 41666 day 15 hour 59 minute                                  | +041666 15:59:00 |
| INTERVAL '-999999:59'HOUR(6) TO MINUTE                                 | -(41666 day 15 hour 59 minute)                               | -041666 15:59:00 |

## Interval HOUR TO SECOND

The followings are examples of using interval HOUR TO SECOND literals.

| Example                                                                                 | Description                                           | Display string      |
|-----------------------------------------------------------------------------------------|-------------------------------------------------------|---------------------|
| INTERVAL '23:59:59.999999'HOUR TO SECOND<br>INTERVAL '00 23:59:59.999999'HOUR TO SECOND | 23 hour 59 minute 59.9999999 second                   | +00 23:59:59.999999 |
| INTERVAL '23:60:59.999999'HOUR TO SECOND                                                | The minute value exceeds 59, so it returns the error. | -                   |
| INTERVAL '23:59:60.999999'HOUR TO SECOND                                                | The second value exceeds 59,                          | -                   |

| Example                                              | Description                                                                                                                  | Display string          |
|------------------------------------------------------|------------------------------------------------------------------------------------------------------------------------------|-------------------------|
|                                                      | so it returns the error.                                                                                                     |                         |
| INTERVAL '99:59:59.9999999'HOUR TO SECOND            | The fractional seconds are rounded off to become 100 hour, then it exceeds the leading precision 2, so it returns the error. | -                       |
| INTERVAL '99:59:59.9999999'HOUR(3) TO SECOND         | 4 day 4 hour                                                                                                                 | +004 04:00:00.000000    |
| INTERVAL '11:22:29.569'HOUR(3) TO SECOND(1)          | 11 hour 22 minute 29.6 second                                                                                                | +000 11:22:29.6         |
| INTERVAL '+9999999:59:59.999999'HOUR(6) TO SECOND(6) | 41666 day 15 hour 59 minute 59.999999 second                                                                                 | +041666 15:59:59.999999 |
| INTERVAL '-9999999:59:59.999999'HOUR(6) TO SECOND(6) | -(41666 day 15 hour 59 minute 59.999999 second)                                                                              | -041666 15:59:59.999999 |

## Interval MINUTE TO SECOND

The followings are examples of using interval MINUTE TO SECOND literals.

| Example                                                                                  | Description                                                                                                                    | Display string          |
|------------------------------------------------------------------------------------------|--------------------------------------------------------------------------------------------------------------------------------|-------------------------|
| INTERVAL '15:23.123456'MINUTE TO SECOND<br>INTERVAL '00 00:15:23.123456'MINUTE TO SECOND | 15 minute 23.123456 second                                                                                                     | +00 00:15:23.123456     |
| INTERVAL '15:60.123456'MINUTE TO SECOND                                                  | The second value exceeds 59, so it returns the error.                                                                          | -                       |
| INTERVAL '99:59.999999'MINUTE TO SECOND(2)                                               | The fractional seconds are rounded off to become 100 minute, then it exceeds the leading precision 2, so it returns the error. | -                       |
| INTERVAL '99:59.999999'MINUTE(3) TO SECOND(2)                                            | 1 hour 40 minute                                                                                                               | +000 01:40:00.00        |
| INTERVAL '+9999999:59.999999'MINUTE(6) TO SECOND(6)                                      | 694 day 10 hour 39 minute 59.999999 second                                                                                     | +000694 10:39:59.999999 |
| INTERVAL '-9999999:59.999999'MINUTE(6) TO SECOND(6)                                      | -(694 day 10 hour 39 minute 59.999999 second)                                                                                  | -000694 10:39:59.999999 |

## Null Value

Null value is an unknown value or an undefined value. NULL value can be a value of any data type. The unknown value of the boolean type is represented as null value.

Null value is defined as a keyword and it is not case-sensitive.

The following is an example of null value representation.

```
NULL
Null
```

## Comments

### Single Line Comment

A single line comment is a comment which starts with `--` or `//`. The single line comment processes a comment from the behind of the comment's symbol to the end of the line.

The following is an example of using a single line comment.

```
gSQL> SELECT I1, -- I2, I3,
2 I4, I5
3 FROM T1;
I1      I4      I5
-----
column i1 column i4 column i5
1 row selected.
gSQL> SELECT I1, // I2, I3,
2 I4, I5
3 FROM T1;
I1      I4      I5
-----
column i1 column i4 column i5
1 row selected.
```

### Multiple Line Comment

A multiple line comment is a comment which starts with `/*` and ends with `*/`. Multiple line comments specify a comment from `/*` to `*/`, and it can use multiple lines to represent comments.



The following is an example of using multiple line comment.

```
gSQL> SELECT I1, I2, I3, I4, I5
2  /* Output
3  all columns of TABLE T1 */
4  FROM T1;
I1      I2      I3      I4      I5
-----
column i1 column i2 column i3 column i4 column i5
1 row selected.
```

## Hint Comment

A hint comment is a comment which starts with `/*+` and ends with `*/`. Hint comment is similar to multiple line comment, but the difference is that the hint comment has `+` at the beginning.

Do not use a space between `*` and `+`. If so, it will be treated as multiple line comment.

Unlike other comments, a hint comment is specified to be used only at the location which is right after the `SELECT` keyword. The processing method which a user specified to `GOLDILOCKS` optimizer is described in the hint comment. For more information, refer to [SQL Hint](#).

The following is an example of using hint comment.

```
gSQL> SELECT /*+ FULL(T1) */ * FROM T1;
I1      I2      I3      I4      I5
-----
column i1 column i2 column i3 column i4 column i5
1 row selected.
```

## SQL Reserved Words and Keywords

### SQL Reserved Words

`GOLDILOCKS` supports reserved words which are specified as SQL reserved words. The SQL reserved word can not be used other than specified location.

SQL reserved words can be used as identifiers by using double quotes (`"`), but it is not recommended to use it as follows, because readability decreases.

```

gSQL> CREATE TABLE "SELECT" ( "FROM" INTEGER );
Table created.
gSQL> INSERT INTO "SELECT" ( "FROM" ) VALUES (1 );
1 row created.
gSQL> SELECT "FROM" FROM "SELECT";
FROM
----
  1
1 row selected.

```

The followings are SQL reserved words of GOLDILOCKS. \* marked SQL reserved words are supported by the SQL standard.

For more information about the list, refer to **V\$RESERVED\_WORDS**.

ABSOLUTE  
 ACCESS  
 ALL \*  
 ALLOCATE \*  
 ALTER \*  
 AND \*  
 ANY \*  
 ARE \*  
 AS \*  
 ASYMMETRIC \*  
 AT \*  
 AUTHORIZATION \*  
 BEGIN \*  
 BETWEEN \*  
 BOTH \*  
 BY \*  
 CALL \*  
 CASE \*  
 CHECK \*  
 CLOSE \*  
 COLUMN \*  
 COMMENT  
 COMMIT \*  
 CONNECT \*  
 CONSTRAINT \*  
 CREATE \*  
 CROSS \*

CURRENT \*  
CURRENT\_CATALOG \*  
CURRENT\_DATE \*  
CURRENT\_DEFAULT\_TRANSFORM\_GROUP \*  
CURRENT\_PATH \*  
CURRENT\_ROLE \*  
CURRENT\_ROW \*  
CURRENT\_SCHEMA \*  
CURRENT\_TIME \*  
CURRENT\_TIMESTAMP \*  
CURRENT\_TRANSFORM\_GROUP\_FOR\_TYPE \*  
CURRENT\_USER \*  
DATABASE  
DEALLOCATE \*  
DECLARE \*  
DEFAULT \*  
DELETE \*  
DEREF \*  
DESCRIBE \*  
DETERMINISTIC \*  
DISCONNECT \*  
DISTINCT \*  
DROP \*  
ELSE \*  
END \*  
END\_EXEC \*  
ESCAPE \*  
EXCEPT \*  
EXEC \*  
EXECUTE \*  
EXISTS \*  
FALSE \*  
FETCH \*  
FILTER \*  
FIRST  
FOR \*  
FOREIGN \*  
FREE \*  
FROM \*  
FULL \*  
FUNCTION \*

GET \*  
GLOBAL \*  
GRANT \*  
GROUP \*  
HAVING \*  
HOLD \*  
IDENTIFIED  
IF  
IMMEDIATE  
IN \*  
INDICATOR \*  
INNER \*  
INOUT \*  
INSERT \*  
INTERSECT \*  
INTO \*  
IS \*  
JOIN \*  
LAST  
LEADING \*  
LEFT \*  
LIKE \*  
LIMIT  
LOCAL \*  
LOCALTIME \*  
LOCALTIMESTAMP \*  
MATCH \*  
MEMBER \*  
MERGE \*  
MINUS  
NATURAL \*  
NEW \*  
NEXT  
NOT \*  
NULL \*  
OF \*  
OFFSET \*  
OLD \*  
ON \*  
OPEN \*  
OR \*

ORDER \*  
OUT \*  
PREPARE \*  
PRIMARY \*  
PRIOR  
PROCEDURE \*  
PROFILE  
REF \*  
REFERENCES \*  
RELATIVE  
RELEASE \*  
RENAME  
RETURN \*  
RETURNING  
RETURNS \*  
REVOKE \*  
RIGHT \*  
ROLLBACK \*  
ROW \*  
ROWID  
ROWS \*  
ROW\_NUMBER \*  
SAVEPOINT \*  
SELECT \*  
SESSION\_USER \*  
SET \*  
SOME \*  
SQL \*  
SQLEXCEPTION \*  
SQLSTATE \*  
SQLWARNING \*  
START \*  
SYMMETRIC \*  
SYNONYM  
SYSDATE  
SYSTEM \*  
SYSTEM\_USER \*  
SYSTIME  
SYSTIMESTAMP  
TABLE \*  
THEN \*

TO \*  
 TRAILING \*  
 TRIGGER \*  
 TRUE \*  
 TRUNCATE \*  
 UNION \*  
 UNIQUE \*  
 UNKNOWN \*  
 UPDATE \*  
 UPPER \*  
 USER \*  
 USING \*  
 VALUES \*  
 VIEW  
 WHEN \*  
 WHENEVER \*  
 WHERE \*  
 WINDOW \*  
 WITH \*  
 WITHOUT \*

## SQL Keywords

GOLDILOCKS SQL keywords are not reserved words. However, they are keywords which are internally used by GOLDILOCKS. Therefore, it is not recommended to use GOLDILOCKS SQL keywords because it can decrease the readability of the results.

GOLDILOCKS SQL keywords list can be viewed through **V\$KEYWORDS**.

## Compatibility for Syntax Elements

The SQL standard compatibility for syntax element is as follows.

**Table 11-1** SQL standard compatibility for syntax element

| Feature ID | Description                                                                   | Availability |
|------------|-------------------------------------------------------------------------------|--------------|
| E021-03    | Character literals                                                            | O            |
| E131       | Null value support (nulls in lieu of values)                                  | O            |
| E161       | SQL comments using leading double minus                                       | O            |
| F051-01    | DATE data type (including support of DATE literal)                            | O            |
|            | TIME data type (including support of TIME literal) with fractional seconds pr |              |

| Feature ID | Description                                                                                                        | Availability |
|------------|--------------------------------------------------------------------------------------------------------------------|--------------|
| F051-02    | recision of at least 0                                                                                             | O            |
| F051-03    | TIMESTAMP data type (including support of TIMESTAMP literal) with fractional seconds precision of at least 0 and 6 | O            |
| F271       | Compound character literals                                                                                        | X            |
| F383       | Set column not null clause                                                                                         | O            |
| F391       | Long identifiers                                                                                                   | X            |
| F392       | Unicode escapes in identifiers                                                                                     | X            |
| F393       | Unicode escapes in literals                                                                                        | X            |
| T023       | Compound binary literals                                                                                           | X            |
| T024       | Spaces in binary literals                                                                                          | X            |
| T101       | Enhanced nullability determination                                                                                 | X            |
| T351       | Bracketed comments                                                                                                 | X            |
| T591       | UNIQUE constraints of possibly null columns                                                                        | O            |
| X041       | Basic table mapping: null absent                                                                                   | X            |
| X042       | Basic table mapping: null as nil                                                                                   | X            |
| X051       | Advanced table mapping: null absent                                                                                | X            |
| X052       | Advanced table mapping: null as nil                                                                                | X            |
| X170       | XML null handling options                                                                                          | X            |
| X400       | Name and identifier mapping                                                                                        | X            |

## 11.2 Data Type

### Numeric Type

Numeric data types are classified according to the storage method and the fractional part representation.

- Classification by the storage method
  - Decimal numeric type
    - It stores decimal numbers in 100 digits basis.
    - Types: NUMBER, NUMERIC, FLOAT
  - Binary numeric type
    - It stores numbers of C language as it is.
    - Types: NATIVE\_INTEGER, NATIVE\_DOUBLE
- Classification by fractional part representation
  - Fixed point data type (exact numeric)
    - It is a numeric type whose scale is fixed.
    - Types: NUMERIC(precision, scale), NATIVE\_INTEGER
  - Floating point data type (approximate numeric)
    - It is a numeric type whose scale is not fixed.
    - Types: FLOAT(precision), NATIVE\_DOUBLE

### Decimal Numeric Type

This type's precision and scale are based on decimal number. The precision indicates accuracy of the valid digits, and the scale indicates the range of fraction.

### Decimal Fixed Point Number Type

The decimal fixed point number type is defined in SQL.

**Table 11-2** Decimal fixed point number type

| Type            | Decimal precision | Decimal scale | Refer to           |
|-----------------|-------------------|---------------|--------------------|
| NUMBER( p )     | p                 | 0             | NUMBER             |
| NUMBER( p, s )  | p                 | s             | NUMBER             |
| NUMERIC( p )    | p                 | 0             | NUMERIC            |
| NUMERIC( p, s ) | p                 | s             | NUMERIC            |
| DECIMAL( p )    | p                 | 0             | NUMERIC type alias |
| DECIMAL( p, s ) | p                 | s             | NUMERIC type alias |



| Type        | Decimal precision | Decimal scale | Refer to           |
|-------------|-------------------|---------------|--------------------|
| DEC( p )    | p                 | 0             | NUMERIC type alias |
| DEC( p, s ) | p                 | s             | NUMERIC type alias |
| SMALLINT    | 5                 | 0             | NUMBER type alias  |
| INTEGER     | 10                | 0             | NUMBER type alias  |
| BIGINT      | 19                | 0             | NUMBER type alias  |
| INT2        | 5                 | 0             | NUMBER type alias  |
| INT4        | 10                | 0             | NUMBER type alias  |
| INT8        | 19                | 0             | NUMBER type alias  |

## Decimal Floating Point Number Type

The decimal floating point number type is defined in SQL.

**Table 11-3** Decimal floating point number type

| Type       | Decimal precision                    | Decimal scale | Refer to         |
|------------|--------------------------------------|---------------|------------------|
| NUMBER     | 38                                   | N/A           | NUMBER           |
| FLOAT( p ) | $\text{ceil}(\log_{10} 2^p)$         | N/A           | FLOAT            |
| REAL       | $\text{ceil}(\log_{10} 2^{24}) = 8$  | N/A           | FLOAT type alias |
| DOUBLE     | $\text{ceil}(\log_{10} 2^{53}) = 16$ | N/A           | FLOAT type alias |
| FLOAT4     | $\text{ceil}(\log_{10} 2^{24}) = 8$  | N/A           | FLOAT type alias |
| FLOAT8     | $\text{ceil}(\log_{10} 2^{53}) = 16$ | N/A           | FLOAT type alias |

## Binary Number Type

This type's precision and scale are based on binary number. The precision indicates accuracy of the valid digits, and the scale indicates the range of fraction.

## Binary Fixed Point Number Type

The binary fixed point number type refers to the signed integer data type of C language.

1 bit is used to represent the sign bit, and other bits are used to represent the precision, but not any bit is used to represent the scale.

**Table 11-4** Binary fixed point number type

| Type            | Binary precision | Binary scale | Refer to        |
|-----------------|------------------|--------------|-----------------|
| NATIVE_SMALLINT | 15               | 0            | NATIVE_SMALLINT |
| NATIVE_INTEGER  | 31               | 0            | NATIVE_INTEGER  |
| NATIVE_BIGINT   | 63               | 0            | NATIVE_BIGINT   |

## Binary Floating Point Number Type

The binary floating point type refers to the float and double data type in C language.

1 bit is used to represent the sign bit, and other bits are used to represent the precision and scale.

**Table 11-5** Binary floating point number type

| Type          | Binary precision | Binary scale | Refer to      |
|---------------|------------------|--------------|---------------|
| NATIVE_REAL   | 23               | 8            | NATIVE_REAL   |
| NATIVE_DOUBLE | 52               | 11           | NATIVE_DOUBLE |



The precision and scale of binary floating point type is subject to change depending on the influence of the compiler and OS.

## CHARACTER STRING Type

CHARACTER STRING data types are classified according to whether it is a variable length string and the maximum length of string.

- Classification by whether it is a variable length string
  - Fixed length string
    - Refer to **CHARACTER**.
  - Variable length string
    - Refer to **CHARACTER VARYING**, **CHARACTER LONG VARYING**.
- Classification by the maximum length of a string
  - 2000 [ characters or bytes ]
    - Refer to **CHARACTER**.
  - 4000 [ characters or bytes ]
    - Refer to **CHARACTER VARYING**.
  - 100 megabytes
    - Refer to **CHARACTER LONG VARYING**.

## BINARY STRING Type

BINARY STRING data types are classified according to whether it is a variable length binary string and the maximum length of binary string.

- Classification by whether it is a variable length binary string

- Fixed length binary string
  - Refer to **BINARY**.
- Variable length binary string
  - Refer to **BINARY VARYING, BINARY LONG VARYING**.
- Classification by the maximum length of binary string
  - 2000
    - Refer to **BINARY**.
  - 4000
    - Refer to **BINARY VARYING**.
  - 100 Mega Bytes
    - Refer to **BINARY LONG VARYING**.

## Date/ Time Type

Date/ time data type specifies the year, month, day, hour, minute, second, time zone offset in accordance with their representation method.

Date/ time type has **DATE, TIME, TIMESTAMP** types.

## INTERVAL Type

INTERVAL data type specifies the time interval.

It specifies the time interval of the year, month, day, hour, minute, second in accordance with their representation method.

**INTERVAL** data types are classified to the YEAR TO MONTH family type and the DAY TO SECOND family type, according to the range of value representation.

## BOOLEAN Type

The BOOLEAN data type stores truth value of TRUE, FALSE, UNKNOWN. UNKNOWN value is represented as a null value. All expressions used as conditions return the BOOLEAN value and the column or the value defined as a BOOLEAN data type can be used as a condition.

The following literals can be stored in the boolean data type.

- TRUE
  - Keyword: TRUE

- Literal: 't', 'true', 'y', 'yes', 'on', '1'
- FALSE
  - Keyword: FALSE
  - Literal: 'f', 'false', 'n', 'no', 'off', '0'
- UNKNOWN
  - Keyword: UNKNOWN, NULL

For more information, refer to **BOOLEAN**.

## ROWID Type

All records stored in the database have unique location information. The record identifier (ROWID) is used to distinguish each record.

ROWID data type is used to store and manage the record identifier (ROWID).

Record identifier (ROWID) is obtained by the query using the ROWID pseudo column.

For more information, refer to **ROWID**.

## Type Comparison

Comparing two types is executed on the basis of one representative type. If the comparison target type is different from the representative type, then the comparison can go through a type conversion.

**The representative types for type comparison** defines the representative type for comparing two types.

The following table describes target type conversion for comparison per each representative type.

- Type conversion for the VC comparison
- Type conversion for the LC comparison
- Type conversion for the VB comparison
- Type conversion for the LB comparison
- Type conversion for the NB comparison
- Type conversion for the ND comparison
- Type conversion for the NU comparison
- Type conversion for the DA comparison
- Type conversion for the TI comparison
- Type conversion for the TZ comparison
- Type conversion for the TS comparison
- Type conversion for the SZ comparison

- Type conversion for the YM comparison
- Type conversion for the DS comparison
- Type conversion for the BO comparison
- Type conversion for the RI comparison



The followings are abbreviations which are used for the type comparison.

- "VC": CHARACTER VARYING
- "LC": CHARACTER LONG VARYING
- "VB": BINARY VARYING
- "LB": BINARY LONG VARYING
- "NB": NATIVE\_BIGINT
- "ND": NATIVE\_DOUBLE
- "NU": NUMBER
- "DA": DATE
- "TI": TIME
- "TZ": TIME WITH TIMEZONE
- "TS": TIMESTAMP
- "SZ": TIMESTAMP WITH TIMEZONE
- "YM": INTERVAL YEAR TO MONTH
- "DS": INTERVAL DAY TO SECOND
- "BO": BOOLEAN
- "RI": ROWID



In the type comparison table, the built-in data types are represented by an abbreviated word enclosed in double quotes ("").

- "CHAR": CHARACTER
- "VARCHAR": CHARACTER VARYING
- "LONG VARCHAR": CHARACTER LONG VARYING
- "VARBINARY": BINARY VARYING
- "LONG VARBINARY": BINARY LONG VARYING
- "TIME\_TZ": TIME WITH TIMEZONE
- "TIMESTAMP\_TZ": TIMESTAMP WITH TIMEZONE
- "INTERVAL\_YM": INTERVAL YEAR TO MONTH
- "INTERVAL\_DS": INTERVAL DAY TO SECOND



| Data type      | CHAR | VARCHAR | LONG | BINARY | VARBINARY | LONGVAR | NVARCHAR | NVARCHAR | NVARCHAR | NVARCHAR | NVARCHAR | NVARCHAR | NVARCHAR | NUMERIC | DECIMAL | TIME | TIME | TIME | TIME | INT | INT | BIT | ROWID |
|----------------|------|---------|------|--------|-----------|---------|----------|----------|----------|----------|----------|----------|----------|---------|---------|------|------|------|------|-----|-----|-----|-------|
| NUMBER         | NU   | NU      | NU   |        |           |         | NU       | NU       | NU       | NU       | ND       | NU       | NU       | NU      |         |      |      |      |      | YM  | DS  |     |       |
| NUMERIC        | NU   | NU      | NU   |        |           |         | NU       | NU       | NU       | NU       | ND       | NU       | NU       | NU      |         |      |      |      |      | YM  | DS  |     |       |
| FLOAT          | NU   | NU      | NU   |        |           |         | NU       | NU       | NU       | NU       | ND       | NU       | NU       | NU      |         |      |      |      |      | YM  | DS  |     |       |
| DATE           | DA   | DA      | DA   |        |           |         |          |          |          |          |          |          |          |         | DA      |      |      | TS   | SZ   |     |     |     |       |
| TIME           | TI   | TI      | TI   |        |           |         |          |          |          |          |          |          |          |         |         | TI   | TZ   |      |      |     |     |     |       |
| TIME_TZ        | TZ   | TZ      | TZ   |        |           |         |          |          |          |          |          |          |          |         |         | TZ   | TZ   |      |      |     |     |     |       |
| TIMES TAMP     | TS   | TS      | TS   |        |           |         |          |          |          |          |          |          |          |         | TS      |      |      | TS   | SZ   |     |     |     |       |
| TIMES TAMP _TZ | SZ   | SZ      | SZ   |        |           |         |          |          |          |          |          |          |          |         | SZ      |      |      | SZ   |      |     |     |     |       |
| INTER VAL_Y M  | YM   | YM      | YM   |        |           |         | YM       | YM       | YM       |          |          | YM       | YM       | YM      |         |      |      |      |      | YM  |     |     |       |
| INTER VAL_D S  | DS   | DS      | DS   |        |           |         | DS       | DS       | DS       |          |          | DS       | DS       | DS      |         |      |      |      |      |     | DS  |     |       |
| BOOLE AN       | B0   | B0      | B0   |        |           |         |          |          |          |          |          |          |          |         |         |      |      |      |      |     |     | B0  |       |
| ROWI D         | RI   | RI      | RI   |        |           |         |          |          |          |          |          |          |          |         |         |      |      |      |      |     |     |     | RI    |

Table 11-7 Type conversion for the VC comparison

| Source type | Converted type       |
|-------------|----------------------|
| CHAR        | CHAR (no conversion) |

| Source type | Converted type          |
|-------------|-------------------------|
| VARCHAR     | VARCHAR (no conversion) |

**Table 11-8** Type conversion for the LC comparison

| Source type  | Converted type               |
|--------------|------------------------------|
| CHAR         | CHAR (no conversion)         |
| VARCHAR      | VARCHAR (no conversion)      |
| LONG VARCHAR | LONG VARCHAR (no conversion) |

**Table 11-9** Type conversion for the VB comparison

| Source type | Converted type            |
|-------------|---------------------------|
| BINARY      | BINARY (no conversion)    |
| VARBINARY   | VARBINARY (no conversion) |

**Table 11-10** Type conversion for the LB comparison

| Source type    | Converted type                 |
|----------------|--------------------------------|
| BINARY         | BINARY (no conversion)         |
| VARBINARY      | VARBINARY (no conversion)      |
| LONG VARBINARY | LONG VARBINARY (no conversion) |

**Table 11-11** Type conversion for the NB comparison

| Source type     | Converted type                  |
|-----------------|---------------------------------|
| CHAR            | NATIVE_BIGINT                   |
| VARCHAR         | NATIVE_BIGINT                   |
| LONG VARCHAR    | NATIVE_BIGINT                   |
| NATIVE_SMALLINT | NATIVE_SMALLINT (no conversion) |
| NATIVE_INTEGER  | NATIVE_INTEGER (no conversion)  |
| NATIVE_BIGINT   | NATIVE_BIGINT (no conversion)   |

**Table 11-12** Type conversion for the ND comparison

| Source type     | Converted type                  |
|-----------------|---------------------------------|
| CHAR            | NATIVE_DOUBLE                   |
| VARCHAR         | NATIVE_DOUBLE                   |
| LONG VARCHAR    | NATIVE_DOUBLE                   |
| NATIVE_SMALLINT | NATIVE_SMALLINT (no conversion) |
| NATIVE_INTEGER  | NATIVE_INTEGER (no conversion)  |
| NATIVE_BIGINT   | NATIVE_BIGINT (no conversion)   |
| NATIVE_REAL     | NATIVE_REAL (no conversion)     |
| NATIVE_DOUBLE   | NATIVE_DOUBLE (no conversion)   |



| Source type | Converted type          |
|-------------|-------------------------|
| NUMBER      | NUMBER (no conversion)  |
| NUMERIC     | NUMERIC (no conversion) |
| FLOAT       | FLOAT (no conversion)   |

**Table 11-13** Type conversion for the NU comparison

| Source type     | Converted type                  |
|-----------------|---------------------------------|
| CHAR            | NUMBER                          |
| VARCHAR         | NUMBER                          |
| LONG VARCHAR    | NUMBER                          |
| NATIVE_SMALLINT | NATIVE_SMALLINT (no conversion) |
| NATIVE_INTEGER  | NATIVE_INTEGER (no conversion)  |
| NATIVE_BIGINT   | NATIVE_BIGINT (no conversion)   |
| NATIVE_REAL     | NATIVE_REAL (no conversion)     |
| NATIVE_DOUBLE   | NATIVE_DOUBLE (no conversion)   |
| NUMBER          | NUMBER (no conversion)          |
| NUMERIC         | NUMERIC (no conversion)         |
| FLOAT           | FLOAT (no conversion)           |

**Table 11-14** Type conversion for the DA comparison

| Source type  | Converted type       |
|--------------|----------------------|
| CHAR         | DATE                 |
| VARCHAR      | DATE                 |
| LONG VARCHAR | DATE                 |
| DATE         | DATE (no conversion) |

**Table 11-15** Type conversion for the TI comparison

| Source type  | Converted type       |
|--------------|----------------------|
| CHAR         | TIME                 |
| VARCHAR      | TIME                 |
| LONG VARCHAR | TIME                 |
| TIME         | TIME (no conversion) |

**Table 11-16** Type conversion for the TZ comparison

| Source type  | Converted type          |
|--------------|-------------------------|
| CHAR         | TIME_TZ                 |
| VARCHAR      | TIME_TZ                 |
| LONG VARCHAR | TIME_TZ                 |
| TIME         | TIME_TZ                 |
| TIME_TZ      | TIME_TZ (no conversion) |

**Table 11-17** Type conversion for the TS comparison

| Source type  | Converted type            |
|--------------|---------------------------|
| CHAR         | TIMESTAMP                 |
| VARCHAR      | TIMESTAMP                 |
| LONG VARCHAR | TIMESTAMP                 |
| DATE         | DATE (no conversion)      |
| TIMESTAMP    | TIMESTAMP (no conversion) |

**Table 11-18** Type conversion for the SZ comparison

| Source type  | Converted type               |
|--------------|------------------------------|
| CHAR         | TIMESTAMP_TZ                 |
| VARCHAR      | TIMESTAMP_TZ                 |
| LONG VARCHAR | TIMESTAMP_TZ                 |
| DATE         | TIMESTAMP_TZ                 |
| TIMESTAMP    | TIMESTAMP_TZ                 |
| TIMESTAMP_TZ | TIMESTAMP_TZ (no conversion) |

**Table 11-19** Type conversion for the YM comparison

| Source type     | Converted type              |
|-----------------|-----------------------------|
| CHAR            | INTERVAL_YM                 |
| VARCHAR         | INTERVAL_YM                 |
| LONG VARCHAR    | INTERVAL_YM                 |
| NATIVE_SMALLINT | INTERVAL_YM                 |
| NATIVE_INTEGER  | INTERVAL_YM                 |
| NATIVE_BIGINT   | INTERVAL_YM                 |
| NUMBER          | INTERVAL_YM                 |
| NUMERIC         | INTERVAL_YM                 |
| FLOAT           | INTERVAL_YM                 |
| INTERVAL_YM     | INTERVAL_YM (no conversion) |

**Table 11-20** Type conversion for the DS comparison

| Source type     | Converted type |
|-----------------|----------------|
| CHAR            | INTERVAL_DS    |
| VARCHAR         | INTERVAL_DS    |
| LONG VARCHAR    | INTERVAL_DS    |
| NATIVE_SMALLINT | INTERVAL_DS    |
| NATIVE_INTEGER  | INTERVAL_DS    |
| NATIVE_BIGINT   | INTERVAL_DS    |
| NUMBER          | INTERVAL_DS    |
| NUMERIC         | INTERVAL_DS    |

| Source type | Converted type              |
|-------------|-----------------------------|
| FLOAT       | INTERVAL_DS                 |
| INTERVAL_DS | INTERVAL_DS (no conversion) |

**Table 11-21** Type conversion for the BO comparison

| Source type  | Converted type          |
|--------------|-------------------------|
| CHAR         | BOOLEAN                 |
| VARCHAR      | BOOLEAN                 |
| LONG VARCHAR | BOOLEAN                 |
| BOOLEAN      | BOOLEAN (no conversion) |

**Table 11-22** Type conversion for the RI comparison

| Source type  | Converted type        |
|--------------|-----------------------|
| CHAR         | ROWID                 |
| VARCHAR      | ROWID                 |
| LONG VARCHAR | ROWID                 |
| ROWID        | ROWID (no conversion) |

## Type Conversion

Type conversions are classified into implicit type conversion and explicit type conversion.

- Implicit type conversion occurs in an expression, an operator, a function, a condition, for select, insert, delete, update.
- Explicit type conversion occurs through the CAST operator.

**The availability of type conversion** describes the availability of data type conversion from a type to another type.



In the type conversion table, the built-in data types are represented by an abbreviated string enclosed in double quotes ("").

- "CHAR": CHARACTER
- "VARCHAR": CHARACTER VARYING
- "LONG VARCHAR": CHARACTER LONG VARYING
- "VARBINARY": BINARY VARYING
- "LONG VARBINARY": BINARY LONG VARYING
- "TIME\_TZ": TIME WITH TIMEZONE
- "TIMESTAMP\_TZ": TIMESTAMP WITH TIMEZONE





- Conversion to CHARACTER type
  - When the source type is CHARACTER type:
    - If the source type precision is bigger than the CHARACTER type precision, then an error occurs.
    - If the source type precision is equal to the CHARACTER type precision, then the string is not changed.
    - If the source type precision is smaller than the CHARACTER type precision, then space characters are added to the string as many as the precision difference.
  - When the source type is CHARACTER VARYING type or CHARACTER LONG VARYING type:
    - If the source type string length is bigger than the CHARACTER type precision, then an error occurs.
    - If the source type string length is equal to the CHARACTER type precision, then the string is not changed.
    - If the source type string length is smaller than the CHARACTER type precision, then space characters are added to the string as many as precision difference.
  - When the source type is numeric type, date/time type, INTERVAL type, BOOLEAN type or ROWID type:
    - If the converted string length of the source type is bigger than the CHARACTER type precision, then an error occurs.
    - If the converted string length of the source type is equal to the CHARACTER type precision, then the string is not changed.
    - If the converted string length of the source type is smaller than the CHARACTER type precision, then space characters are added to the string as many as precision difference.
- Conversion to CHARACTER VARYING type
  - When the source type is CHARACTER type:
    - If the source type precision is bigger than the CHARACTER VARYING type precision, then an error occurs.
    - If the source type precision is equal or smaller than the CHARACTER VARYING type precision, then the string is not changed.
  - When the source type is CHARACTER VARYING type or CHARACTER LONG VARYING type:
    - If the source type string length is bigger than the CHARACTER VARYING type precision, then an error occurs.
    - If the source type string length is equal or smaller than the CHARACTER VARYING type precision, then the string is not changed.
  - When the source type is numeric type, date/time type, INTERVAL type, BOOLEAN type or ROWID type:
    - If the converted string length of the source type is bigger than the CHARACTER VARYING type precision, then an error occurs.
    - If the converted string length of the source type is equal or smaller than the CHARACTER VARYING type precision, then the string is not changed.
- Conversion to CHARACTER LONG VARYING type
  - When the source type is CHARACTER STRING type:

- The source type string is not changed.
- When the source type is numeric type, date/time type, INTERVAL type, BOOLEAN type or ROWID type:
  - The converted string of the source type is not changed.
- Conversion to BINARY type
  - When the source type is BINARY type:
    - If the source type precision is bigger than the BINARY type precision, then an error occurs.
    - If the source type precision is equal to the BINARY type precision, then the binary string is not changed.
    - If the source type precision is smaller than the BINARY type precision, the X'00' characters are added to the binary string as many as the precision difference.
  - When the source type is BINARY VARYING type or BINARY LONG VARYING type:
    - If the source type binary string length is bigger than the BINARY type precision, then an error occurs.
    - If the source type binary string length is equal to the BINARY type precision, then the binary string is not changed.
    - If the source type binary string length is smaller than the BINARY type precision, the X'00' characters are added to a binary string as many as precision difference.
- Conversion to BINARY VARYING type
  - When the source type is BINARY type:
    - If the source type precision is bigger than the BINARY VARYING type precision, then an error occurs.
    - If the source type precision is equal or smaller than the BINARY VARYING type precision, then the binary string is not changed.
  - When the source type is BINARY VARYING type, BINARY LONG VARYING type:
    - If the source type binary string length is bigger than the BINARY VARYING type precision, then an error occurs.
    - If the source type binary string length is equal or smaller than the BINARY VARYING type precision, the binary string is not changed.
- Conversion to BINARY LONG VARYING type
  - If the source type is BINARY STRING type, the source type binary string is not changed.
- Conversion to numeric type
  - When the source type is CHARACTER STRING type:
    - If the string does not comply with the numeric format, then an error occurs.
    - An overflow or rounding can occur due to the precision and scale which is defined in the converted type.
  - When the source type is numeric type:
    - An overflow or rounding can occur due to the precision and scale which is defined in the converted type.

- When the source type is INTERVAL type:
  - It can be converted to the numeric type only when the source type is the single field (YEAR, MONTH, DAY, HOUR, MINUTE, SECOND).
  - An overflow or rounding can occur due to the precision and scale which is defined in the converted type.
- Conversion to DATE type
  - When the source type is CHARACTER STRING type:
    - If the string does not comply with the DATE type format, then an error occurs.
    - An overflow can occur due to a value range which is defined in the converted type.
  - When the source type is DATE type or TIMESTAMP type:
    - The error does not occur.
  - When the source type is TIMESTAMP WITH TIME ZONE type:
    - It is converted to the DATE type value upon consideration of the time zone offset.
- Conversion to TIME type
  - When the source type is CHARACTER STRING type:
    - If the string does not comply with the TIME type format, then an error occurs.
    - A rounding can occur due to a value range which is defined in the converted type.
  - When the source type is TIME type or TIMESTAMP type:
    - The error does not occur.
  - When the source type is TIME WITH TIME ZONE type or TIMESTAMP WITH TIME ZONE type:
    - It is converted to the value of TIME type upon consideration of the time zone offset.
- Conversion to TIME WITH TIME ZONE type
  - When the source type is CHARACTER STRING type:
    - If the string does not comply with the TIME WITH TIME ZONE type format, then an error occurs.
    - A rounding can occur due to a value range which is defined in the converted type.
  - When the source type is TIME type, TIME WITH TIME ZONE type or TIMESTAMP WITH TIME ZONE type:
    - It is converted to the value of TIME WITH TIME ZONE type upon consideration of the time zone offset.
- Conversion to TIMESTAMP type
  - When the source type is CHARACTER STRING type:
    - If the string does not comply with the TIMESTAMP type format, then an error occurs.
    - An overflow or rounding can occur due to a value range which is defined in the converted type.
  - When the source type is DATE type or TIMESTAMP type:
    - The error does not occur.
  - When the source type is TIMESTAMP WITH TIME ZONE type:
    - It is converted to the TIMESTAMP type value upon consideration of the time zone offset.



- Conversion to `TIMESTAMP WITH TIME ZONE` type
  - When the source type is `CHARACTER STRING` type:
    - If the string does not comply with the `TIMESTAMP WITH TIME ZONE` type format, then an error occurs.
    - An overflow or rounding can occur due to a value range which is defined in the converted type.
  - When the source type is `DATE` type, `TIMESTAMP` type or `TIMESTAMP WITH TIME ZONE` type:
    - It is converted to the value of `TIMESTAMP WITH TIME ZONE` type upon consideration of the time zone offset.
- Conversion to `INTERVAL YEAR TO MONTH` family type
  - When the source type is `CHARACTER STRING` type:
    - If the string does not comply with the year-month interval literal format, then an error occurs.
    - For more information, refer to **Interval Literals**.
    - An overflow can occur due to a precision which is defined in the converted type.
  - When the source type is `NATIVE_SMALLINT`, `NATIVE_INTEGER`, `NATIVE_BIGINT`, `NUMBER`, `NUMERIC` or `FLOAT` type:
    - The converted type should be a single field (`YEAR`, `MONTH`).
    - An overflow can occur due to a precision which is defined in the converted type.
  - When the source type is `INTERVAL YEAR TO MONTH` family type:
    - An overflow can occur due to a precision which is defined in the converted type.
- Conversion to `INTERVAL DAY TO SECOND` family type
  - When the source type is `CHARACTER STRING` type:
    - If the string does not comply with the day-time interval literal format, then an error occurs.
    - For more information, refer to **Interval Literals**.
    - An overflow or rounding can occur due to the precision which is defined in the converted type.
  - When the source type is `NATIVE_SMALLINT`, `NATIVE_INTEGER`, `NATIVE_BIGINT`, `NUMBER`, `NUMERIC`, or `FLOAT` type:
    - The converted type should be a single field (`DAY`, `HOUR`, `MINUTE`, `SECOND`)
    - An overflow or rounding can occur due to the precision which is defined in the converted type.
  - When the source type is `INTERVAL DAY TO SECOND` family type:
    - An overflow or rounding can occur due to the precision which is defined in the converted type.
- Conversion to `BOOLEAN` type
  - When the source type is `CHARACTER STRING` type:
    - The conversion is available when the string is `"TRUE"` or `"FALSE"`, and it is case-insensitive. (It is convertible even when the string includes a space before and after it.)
  - When the source type is `BOOLEAN` type:
    - The error does not occur.

- Conversion to ROWID type
  - When the source type is CHARACTER STRING type:
    - If the string does not comply with the ROWID type format, then an error occurs.
  - When the source type is ROWID type:
    - The error does not occur.

## Type Combination

### When Type Combination Is Required

A CASE operator and a **set operator** have many expressions as a result of operation.

Each expression can have different types each other as follows. In this case, the result type should be determined.

- The following describes an execution result of a CASE operator.

```
SELECT CASE expr WHEN expr THEN char(3)
          WHEN expr THEN char(5)
          ELSE char(1)
        END
FROM t1;
```

- The following describes an execution result of a set operator.

```
SELECT float_column
FROM t1
UNION ALL
SELECT number_precision_column
FROM t2
UNION ALL
SELECT native_integer_column
FROM t3;
```

A rule is applied to determine the result type according to the type combination. The following is an example of applying the rule.

- Result type combination rule
  - **set operator**
  - CASE operator
    - CASE Expression

- COALESCE
- NULLIF

## Result Type Combination Rule

Each expression's data type should be the same family type which is available to combine.

- Examples of applying result type combination rule
  - **set operator**
  - CASE operator
    - CASE Expression
    - COALESCE
    - NULLIF

The result types determined by result type combination rule are described in the following table.



The following abbreviations are used to describe the result type combination rule.

- "VC": CHARACTER VARYING
- "LC": CHARACTER LONG VARYING
- "VB": BINARY VARYING
- "LB": BINARY LONG VARYING
- "NS": NATIVE\_SMALLINT
- "NI": NATIVE\_INTEGER
- "NB": NATIVE\_BIGINT
- "NR": NATIVE\_REAL
- "ND": NATIVE\_DOUBLE
- "FL": FLOAT
- "NU": NUMBER
- "DA": DATE
- "TI": TIME
- "TZ": TIME WITH TIMEZONE
- "TS": TIMESTAMP
- "SZ": TIMESTAMP WITH TIMEZONE
- "YM": INTERVAL YEAR TO MONTH
- "DS": INTERVAL DAY TO SECOND
- "BO": BOOLEAN
- "RI": ROWID



| Data type       | CHAR | VARCHAR | LONG | BINARY | VARBINARY | LONGVAR | NVARCHAR | NVARCHAR | NVARCHAR | NVARCHAR | NVARCHAR | NUMERIC | NUMERIC | FLOAT | DATE | TIME | TIME | TIME | TIME | INT | INT | BINARY | ROWID |
|-----------------|------|---------|------|--------|-----------|---------|----------|----------|----------|----------|----------|---------|---------|-------|------|------|------|------|------|-----|-----|--------|-------|
| NARY            |      |         |      |        |           |         |          |          |          |          |          |         |         |       |      |      |      |      |      |     |     |        |       |
| NATIVE_SMALLINT |      |         |      |        |           |         | NS       | NI       | NB       | ND       | ND       | NU      | NU      | NU    |      |      |      |      |      |     |     |        |       |
| NATIVE_INTEGER  |      |         |      |        |           |         | NI       | NI       | NB       | ND       | ND       | NU      | NU      | NU    |      |      |      |      |      |     |     |        |       |
| NATIVE_BIGINT   |      |         |      |        |           |         | NB       | NB       | NB       | ND       | ND       | NU      | NU      | NU    |      |      |      |      |      |     |     |        |       |
| NATIVE_REAL     |      |         |      |        |           |         | ND       | ND       | ND       | NR       | ND       | ND      | ND      | ND    |      |      |      |      |      |     |     |        |       |
| NATIVE_DOUBLE   |      |         |      |        |           |         | ND       | ND       | ND       | ND       | ND       | ND      | ND      | ND    |      |      |      |      |      |     |     |        |       |
| NUMBER          |      |         |      |        |           |         | NU       | NU       | NU       | ND       | ND       | NU      | NU      | NU    |      |      |      |      |      |     |     |        |       |
| NUMERIC         |      |         |      |        |           |         | NU       | NU       | NU       | ND       | ND       | NU      | NU      | NU    |      |      |      |      |      |     |     |        |       |
| FLOAT           |      |         |      |        |           |         | NU       | NU       | NU       | ND       | ND       | NU      | NU      | FL    |      |      |      |      |      |     |     |        |       |
| DATE            |      |         |      |        |           |         |          |          |          |          |          |         |         |       | DA   |      |      | TS   | SZ   |     |     |        |       |
| TIME            |      |         |      |        |           |         |          |          |          |          |          |         |         |       |      | TI   | TZ   |      |      |     |     |        |       |
| TIME_TZ         |      |         |      |        |           |         |          |          |          |          |          |         |         |       |      | TZ   | TZ   |      |      |     |     |        |       |
| TIMESTAMP       |      |         |      |        |           |         |          |          |          |          |          |         |         |       | TS   |      |      | TS   | SZ   |     |     |        |       |
| TIMESTAMP       |      |         |      |        |           |         |          |          |          |          |          |         |         |       | SZ   |      |      | SZ   | SZ   |     |     |        |       |

|             |   |   |   |   |   |   |   |   |   |   |   |   |   |   |   |   |   |   |   |    |    |    |    |
|-------------|---|---|---|---|---|---|---|---|---|---|---|---|---|---|---|---|---|---|---|----|----|----|----|
| Data type   | C | V | L | B | V | L | N | N | N | N | N | N | N | F | D | T | T | T | T | I  | I  | B  | R  |
|             | H | A | O | I | A | O | A | A | A | A | A | U | U | L | A | I | I | I | I | N  | N  | O  | O  |
|             | A | R | N | N | R | N | T | T | T | T | T | M | M | O | T | M | M | M | M | T  | T  | E  | E  |
|             | R | C | G | A | B | G | I | I | I | I | I | B | E | A | E | E | E | E | E | E  | E  | L  | E  |
|             |   | H |   | R | I |   | V | V | V | V | V | E | R | T |   |   | S | S | R | R  | E  | E  | D  |
|             |   | A | V | Y | N | V | E | E | E | E | E | R | I |   |   | T | T | V | V | A  | A  | A  | A  |
|             |   | R | A |   | A | A |   |   |   |   |   | C |   |   |   | A | A | A | A | A  | A  | A  | N  |
|             |   |   | R |   | R | R | S | I | B | R | D |   |   |   |   | T | M | T | L | L  |    |    |    |
|             |   |   |   |   | Y | B | M | N | I | E | O |   |   |   |   | Z | P | M |   |    | Y  | D  |    |
|             |   |   |   |   |   | I | A | T | G | A | U |   |   |   |   |   |   | P |   | M  | S  |    |    |
|             |   |   |   |   |   | N | L | E | I | L | B |   |   |   |   |   |   |   |   |    |    |    |    |
|             |   |   |   |   |   | A | L | G | N |   | L | E |   |   |   |   |   |   |   |    |    |    |    |
|             |   |   |   |   |   | R | I | N | T |   | E |   |   |   |   |   |   |   |   |    |    |    |    |
|             |   |   |   |   |   | Y |   |   |   |   |   |   |   |   |   |   |   |   |   |    |    |    |    |
| TZ          |   |   |   |   |   |   |   |   |   |   |   |   |   |   |   |   |   |   |   |    |    |    |    |
| INTERVAL_YM |   |   |   |   |   |   |   |   |   |   |   |   |   |   |   |   |   |   |   | YM |    |    |    |
| INTERVAL_DS |   |   |   |   |   |   |   |   |   |   |   |   |   |   |   |   |   |   |   |    | DS |    |    |
| BOOLEAN     |   |   |   |   |   |   |   |   |   |   |   |   |   |   |   |   |   |   |   |    |    | B0 |    |
| ROWID       |   |   |   |   |   |   |   |   |   |   |   |   |   |   |   |   |   |   |   |    |    |    | RI |

- The result type of when all is CHAR type
  - If the lengths are different, then it is VARCHAR type.
  - If the lengths are equal, then it is CHAR type.
- The result type of when all is BINARY type
  - If the lengths are different, then it is VARBINARY type.
  - If the lengths are equal, then it is BINARY type.
- The result type of INTERVAL YEAR TO MONTH type
  - If YEAR type and MONTH type are mixed, then it is INTERVAL YEAR TO MONTH type.
  - If there is only YEAR type, then it is INTERVAL YEAR type.
  - If there is only MONTH type, then it is INTERVAL MONTH type.
- The result type of INTERVAL DAY TO SECOND type
  - The start field is the biggest range field of each target expression.
  - The end field is the smallest range field of each target expression.
  - e.g. {INTERVAL DAY, INTERVAL HOUR} => INTERVAL DAY TO HOUR
- The precision, scale of the result type
  - CHARACTER STRING type
    - The maximum character length of the target expression

- BINARY STRING type
  - The maximum character length of the target expression
- NUMERIC type
  - It specifies an acceptable maximum range of the type's value.
- TIME/TIMESTAMP type
  - The maximum fractional seconds precision of the target expression
- INTERVAL YEAR TO MONTH
  - The maximum leading precision of the target expression
- INTERVAL DAY TO SECOND
  - Leading precision is the maximum leading precision of the start field
  - Fractional seconds precision is the maximum fractional seconds precision.
- For more information, refer to **Type Comparison**.

## Compatibility for Data Type

The SQL standard compatibility for data type is as follows.

**Table 11-25** SQL standard compatibility for data type

| Feature ID | Description                                                                        | Availability |
|------------|------------------------------------------------------------------------------------|--------------|
| B033       | Untyped SQL-invoked function arguments                                             | X            |
| E011-01    | INTEGER and SMALLINT data types                                                    | O            |
| E011-02    | REAL, DOUBLE PRECISION, and FLOAT data types                                       | O            |
| E011-03    | DECIMAL and NUMERIC data types                                                     | X            |
| E011-04    | Arithmetic operators                                                               | O            |
| E011-05    | Numeric comparison                                                                 | O            |
| E011-06    | Implicit casting among the numeric data types                                      | O            |
| E021-01    | CHARACTER data type                                                                | O            |
| E021-02    | CHARACTER VARYING data type                                                        | O            |
| E021-03    | Character literals                                                                 | O            |
| E021-04    | CHARACTER_LENGTH function                                                          | O            |
| E021-05    | OCTET_LENGTH function                                                              | O            |
| E021-06    | SUBSTRING function                                                                 | O            |
| E021-07    | Character concatenation                                                            | O            |
| E021-08    | UPPER and LOWER functions                                                          | O            |
| E021-09    | TRIM function                                                                      | O            |
| E021-10    | Implicit casting among the fixed-length and variable-length character string types | O            |
| E021-11    | POSITION function                                                                  | O            |
| E021-12    | Character comparison                                                               | O            |
|            | Columns combined via table operators need not have exactly the same data           |              |

| Feature ID | Description                                                                                                        | Availability |
|------------|--------------------------------------------------------------------------------------------------------------------|--------------|
| E071-05    | type                                                                                                               | O            |
| F051-01    | DATE data type (including support of DATE literal)                                                                 | O            |
| F051-02    | TIME data type (including support of TIME literal) with fractional seconds precision of at least 0                 | O            |
| F051-03    | TIMESTAMP data type (including support of TIMESTAMP literal) with fractional seconds precision of at least 0 and 6 | O            |
| F051-04    | Comparison predicate on DATE, TIME, and TIMESTAMP data types                                                       | X            |
| F051-05    | Explicit CAST between datetime types and character string types                                                    | O            |
| F054       | TIMESTAMP in DATE type precedence list                                                                             | X            |
| F382       | Alter column data type                                                                                             | O            |
| F611       | Indicator data types                                                                                               | X            |
| F741       | Referential MATCH types                                                                                            | X            |
| J521       | JDBC data types                                                                                                    | X            |
| J622       | external Java types                                                                                                | X            |
| S011-01    | USER_DEFINED_TYPES view                                                                                            | X            |
| S023       | Basic structured types                                                                                             | X            |
| S024       | Enhanced structured types                                                                                          | X            |
| S025       | Final structured types                                                                                             | X            |
| S026       | Self-referencing structured types                                                                                  | X            |
| S041       | Basic reference types                                                                                              | X            |
| S043       | Enhanced reference types                                                                                           | X            |
| S051       | Create table of type                                                                                               | X            |
| S071       | SQL paths in function and type name resolution                                                                     | X            |
| S091-01    | Arrays of built-in data types                                                                                      | X            |
| S091-02    | Arrays of distinct types                                                                                           | X            |
| S092       | Arrays of user-defined types                                                                                       | X            |
| S094       | Arrays of reference types                                                                                          | X            |
| S161       | Subtype treatment                                                                                                  | X            |
| S162       | Subtype treatment for references                                                                                   | X            |
| S201-02    | Array as result type of functions                                                                                  | X            |
| S231       | Structured type locators                                                                                           | X            |
| S261       | Specific type method                                                                                               | X            |
| S272       | Multisets of user-defined types                                                                                    | X            |
| S274       | Multisets of reference types                                                                                       | X            |
| S281       | Nested collection types                                                                                            | X            |
| S401       | Distinct types based on array types                                                                                | X            |
| S402       | Distinct types based on distinct types                                                                             | X            |
| T021       | BINARY and VARBINARY data types                                                                                    | O            |
| T022       | Advanced support for BINARY and VARBINARY data types                                                               | O            |
| T031       | BOOLEAN data type                                                                                                  | O            |



| Feature ID | Description                                            | Availability |
|------------|--------------------------------------------------------|--------------|
| T041       | Basic LOB data type support                            | X            |
| T042       | Extended LOB data type support                         | X            |
| T051       | Row types                                              | X            |
| T071       | BIGINT data type                                       | O            |
| T201       | Comparable data types for referential constraints      | X            |
| T322       | Declared data type attributes                          | X            |
| X010       | XML type                                               | X            |
| X011       | Arrays of XML type                                     | X            |
| X012       | XMLMultisets of XML type                               | X            |
| X013       | Distinct types of XML type                             | X            |
| X014       | Attributes of XML type                                 | X            |
| X015       | Fields of XML type                                     | X            |
| X181       | XML(DOCUMENT(UNTYPED)) type                            | X            |
| X182       | XML(DOCUMENT(ANY)) type                                | X            |
| X190       | XML(SEQUENCE) type                                     | X            |
| X191       | XML(DOCUMENT(XMLSCHEMA)) type                          | X            |
| X192       | XML(CONTENT(XMLSCHEMA)) type                           | X            |
| X231       | XML(CONTENT(UNTYPED)) type                             | X            |
| X232       | XML(CONTENT(ANY)) type                                 | X            |
| X251       | Persistent XML values of XML(DOCUMENT(UNTYPED)) type   | X            |
| X252       | Persistent XML values of XML(DOCUMENT(ANY)) type       | X            |
| X253       | Persistent XML values of XML(CONTENT(UNTYPED)) type    | X            |
| X254       | Persistent XML values of XML(CONTENT(ANY)) type        | X            |
| X255       | Persistent XML values of XML(SEQUENCE) type            | X            |
| X256       | Persistent XML values of XML(DOCUMENT(XMLSCHEMA)) type | X            |
| X257       | Persistent XML values of XML(CONTENT(XMLSCHEMA)) type  | X            |
| X260       | XML type: ELEMENT clause                               | X            |
| X261       | XML type: NAMESPACE without ELEMENT clause             | X            |
| X263       | XML type: NO NAMESPACE with ELEMENT clause             | X            |
| X264       | XML type: schema location                              | X            |
| X410       | Alter column data type: XML type                       | X            |

## 11.3 Format String

Format string defines the format which is used when a numeric type or date/time type is converted to a character string or when a character string is converted to a numeric types or date/time type.

- When a numeric type or date/time type is converted to a character string type, the representation format of the string is as follows.
  - Refer to `TO_CHAR( number ), TO_CHAR( datetime )`.
  - Numeric type: `TO_CHAR( 1234.56, 'S9,999.99' )` → '+1,234.56'
  - Date/time type: `TO_CHAR( SYSDATE, 'YYYY-MM-DD' )` → '2012-07-15'
- When a character string is converted to the numeric type or date/time type, the representation format of the string is as follows.
  - Refer to `TO_NUMBER, TO_NATIVE_REAL, TO_NATIVE_DOUBLE`.
  - Refer to `TO_DATE`.
  - Refer to `TO_TIMESTAMP, TO_TIMESTAMP_WITH_TIME_ZONE`.
  - Refer to `TO_TIME, TO_TIME_WITH_TIME_ZONE`.
  - Numeric type: `TO_NUMBER( '+1,234.56', 'S9,999.99' )` → NUMBER TYPE
  - Date/time type: `TO_DATE( '2012-07-15', 'YYYY-MM-DD' )` → DATE TYPE

Format strings are classified according to the type.

- Numeric data type: Refer to **Number Format String**.
- Date/time type: Refer to **Datetime Format String**.

### Number Format String

Number format string defines the format which is used when a numeric type is converted to a character string type, or when a character string type is converted to a numeric type.

Number format string is used as an argument of the functions such as `TO_CHAR( number ), TO_NATIVE_SMALLINT, TO_NATIVE_INTEGER, TO_NATIVE_BIGINT, TO_NUMBER, TO_NATIVE_REAL, TO_NATIVE_DOUBLE`.

Number format string can specify multiple format elements according to the desired format.

All number format elements are rounded off to fit the format.

If the number of digits before the decimal point of the value to be converted is bigger than the number of digits specified in the format string, then they are replaced with '#' character.

If the format element representing the sign of MI, S, PR is not specified, a negative number returns - sign and a positive number returns a white space to the front of the number.

Table 11-26 Number format elements

| Format element | Example      | Description                                                                                                                                                                                                                                                                                                                                                                                                                                                                                                                                                                                        |
|----------------|--------------|----------------------------------------------------------------------------------------------------------------------------------------------------------------------------------------------------------------------------------------------------------------------------------------------------------------------------------------------------------------------------------------------------------------------------------------------------------------------------------------------------------------------------------------------------------------------------------------------------|
| , (comma)      | 9,999        | It returns a comma to the specified position.<br>Multiple commas can be specified.<br>Format string can not begin with a comma, and it can not come after the decimal point (.).                                                                                                                                                                                                                                                                                                                                                                                                                   |
| . (period)     | 99.99        | It returns a decimal point (.) to the specified position.<br>The decimal point in the format string can be specified only once.                                                                                                                                                                                                                                                                                                                                                                                                                                                                    |
| \$             | \$9999       | It returns the \$ sign to the front of the number.                                                                                                                                                                                                                                                                                                                                                                                                                                                                                                                                                 |
| 0              | 0999<br>9990 | It returns zero (0) to the front of or to the end of the number.<br>If the number of digits of the value to be converted is smaller than the number of digits to the zero position of the format string, then the gap is filled with zero (0)s and is returned.                                                                                                                                                                                                                                                                                                                                    |
| 9              | 9999         | It returns a white space and numbers according to the sign and the number of specified 9.<br>If the number of digits of the value to be converted is smaller than the number of the specified 9, then the gap is filled with white spaces and is returned.<br>For a positive number, a white space is returned to the front of the number.<br>For a negative number, '-' symbol is returned to the front of the number.<br>If the value before the format string's decimal point is 0, then 0 is returned as a white space.<br>e.g. TO_CHAR( 0.123, '9.999' ) → .123<br>e.g. TO_CHAR( 0, '9' ) → 0 |
| B              | B9999        | If the value is zero, it returns a white space.                                                                                                                                                                                                                                                                                                                                                                                                                                                                                                                                                    |
| EEEE           | 9.9EEEE      | It returns in exponential notation.<br>It can be at the end of format string or it can be in front of S, MI, PR.<br>It can not be specified together with a comma (,).                                                                                                                                                                                                                                                                                                                                                                                                                             |
| MI             | 9999MI       | For a positive number, a white space is returned to the end of the number.<br>For a negative number, '-' symbol is returned to the end of the number.<br>It can be specified only at the end of format string and it can not be specified together with S, PR.                                                                                                                                                                                                                                                                                                                                     |
| PR             | 9999PR       | For a positive number, white spaces are returned to the beginning and end of the number.<br>For a negative number, it returns the number into the inside of angle brackets. <number><br>It can be specified only at the end of format string, and it can not be specified together with S, MI.                                                                                                                                                                                                                                                                                                     |
| RN<br>rn       | RN<br>rn     | Roman numerals are converted to uppercase and returned. (RN)<br>Roman numerals are converted to lowercase and returned. (rn)<br>Only the numbers between 1 ~ 3999 are returned.<br>It can be specified together only with FM format element, but it can not be specified with any other format elements.                                                                                                                                                                                                                                                                                           |

| Format element | Example        | Description                                                                                                                                                                                                                                                                                                                                                                                                                                                                                                                                                                                                                                                                                                                             |
|----------------|----------------|-----------------------------------------------------------------------------------------------------------------------------------------------------------------------------------------------------------------------------------------------------------------------------------------------------------------------------------------------------------------------------------------------------------------------------------------------------------------------------------------------------------------------------------------------------------------------------------------------------------------------------------------------------------------------------------------------------------------------------------------|
|                |                | It can not be used in TO_NUMBER function.                                                                                                                                                                                                                                                                                                                                                                                                                                                                                                                                                                                                                                                                                               |
| S              | S9999<br>9999S | For a positive number, '+' symbol is returned to the front of the number. For a negative number, '-' symbol is returned to the front of the number. (S9999)<br>For a positive number, '+' symbol is returned to the end of the number. For a negative number, '-' symbol is returned to the end of the number. (9999S)<br>It can be specified only at the beginning of format string or at the end of format string.<br>It can not be specified together with MI, PR.                                                                                                                                                                                                                                                                   |
| V              | 999V99         | $10^n$ (n: the digit number of 9 after V format element) multiplied by the value is returned.<br>It can not specified together with the decimal point (.).<br>It can not be used in TO_NUMBER function.                                                                                                                                                                                                                                                                                                                                                                                                                                                                                                                                 |
| X              | XXXX<br>xxxx   | It returns the white space and hexadecimal number according to the digit number of the specified X.<br>It converts an integer value to the hexadecimal number, and returns it. (A non-integer value is rounded off to make it to an integer value.)<br>XXX returns hexadecimal uppercase letters and xxxx returns hexadecimal lowercase letters.<br>If the number of the converted hexadecimal digit is smaller than the number of the specified X, then the gap is filled with white spaces and is returned.<br>Only 0 and positive integers are processed, and negative numbers are replaced with '#'.<br>It can be specified together only with format element 0 and FM, but it can not be specified with any other format elements. |
| FM             | FM             | It removes the front and end white spaces, and returns left aligned effect.<br>It removes the front and end white spaces of the number.<br>It removes zero(0)s under the decimal point which are added by 9 format element.                                                                                                                                                                                                                                                                                                                                                                                                                                                                                                             |

Followings are examples of using number format string.

```

TO_CHAR( 12345, '99,999' )           : ' 12,345'
TO_CHAR( 123456789, '999,999,999' ) : ' 123,456,789'
TO_CHAR( 12.345, '99.999' )         : ' 12.345'
TO_CHAR( 1234.56, '$9,999.99' )     : ' $1,234.56'
TO_CHAR( 123, '099999' )            : ' 000123'
TO_CHAR( 0.2, '0.9' )               : ' 0.2'
TO_CHAR( 123.45, '999999.99' )     : '   123.45'
TO_CHAR( -123.45, '999999.99' )    : '  -123.45'

```

```

TO_CHAR( 123.45, 'FM999999.99' )      : '123.45'
TO_CHAR( -123.45, 'FM999999.99' )    : '-123.45'
TO_CHAR( 12345.67, '999.99' )        : '#####'
TO_CHAR( 123.100567, '999.999' )     : ' 123.101'
TO_CHAR( 0.2, '90.99' )              : '  0.20'
TO_CHAR( 0.2, '99.99' )              : '   .20'
TO_CHAR( 0, '90.99' )                : '  0.00'
TO_CHAR( 0, 'B90.99' )               : '      '
TO_CHAR( 123.45, '9.9EEEE' )         : '  1.2E+02'
TO_CHAR( 123.45, '999.99MI' )        : '123.45 '
TO_CHAR( -123.45, '999.99MI' )       : '123.45-'
TO_CHAR( 123.45, '999.99PR' )        : ' 123.45 '
TO_CHAR( -123.45, '999.99PR' )       : '<123.45>'
TO_CHAR( 123, 'RN' )                 : '          CXXIII'
TO_CHAR( 123, 'rn' )                 : '          cxxiii'
TO_CHAR( 123, 'FMRN' )               : 'CXXIII'
TO_CHAR( 4000, 'RN' )                : '#####'
TO_CHAR( 123.45, 'S999.99' )         : '+123.45'
TO_CHAR( -123.45, 'S999.99' )        : '-123.45'
TO_CHAR( 123.45, '999.99S' )         : '123.45+'
TO_CHAR( -123.45, '999.99S' )        : '123.45-'
TO_CHAR( 123.45, '999V999' )         : ' 123450'
TO_CHAR( 123, 'XX' )                 : '  7B'
TO_CHAR( 123, 'xx' )                 : '  7b'
TO_CHAR( 45678, 'XXXXXXX' )          : '      B26E'
TO_CHAR( 45678, 'FMXXXXXXX' )        : 'B26E'
TO_CHAR( 123.45, '99,999.999999' )   : '   123.450000'
TO_CHAR( 123.45, 'FM99,999.999999' ) : '123.45'

```

## Datetime Format String

Datetime format string defines the format which is used when a date/time type is converted to a character string type, or when a character string type is converted to a date/time type.

Datetime format string is used as an argument of the functions such as `TO_CHAR( datetime )`, `TO_DATE`, `TO_TIMESTAMP`, `TO_TIMESTAMP_WITH_TIME_ZONE`, `TO_TIME`, `TO_TIME_WITH_TIME_ZONE`.

For datetime format string, if the format string is not specified, then the default value is used. The default value of each type is specified in the session property (`NLS_*_FORMAT`).

- DATE: Refer to **NLS\_DATE\_FORMAT**.
- TIMESTAMP: Refer to **NLS\_TIMESTAMP\_FORMAT**.
- TIMESTAMP WITH TIME ZONE: Refer to **NLS\_TIMESTAMP\_WITH\_TIME\_ZONE\_FORMAT**.
- TIME: Refer to **NLS\_TIME\_FORMAT**.
- TIME WITH TIME ZONE: Refer to **NLS\_TIME\_WITH\_TIME\_ZONE\_FORMAT**.

NLS \* \_FORMAT values can be changed by using **ALTER SESSION SET property\_name**.

In datetime format string, multiple format elements can be specified upon the desired representation.

**Table 11-27** Datetime format elements

| Format element                                             | Whether to use T O_* datetime | Description                                                                                                                                                                                                                                                                                                                        |
|------------------------------------------------------------|-------------------------------|------------------------------------------------------------------------------------------------------------------------------------------------------------------------------------------------------------------------------------------------------------------------------------------------------------------------------------|
| -<br>/<br>,<br>.<br>;<br>:<br>"text"<br>Special characters | Y                             | It returns the format element character to the specified location.                                                                                                                                                                                                                                                                 |
| AD<br>A.D.                                                 | Y                             | AD with or without periods.                                                                                                                                                                                                                                                                                                        |
| AM<br>A.M.                                                 | Y                             | AM with or without periods.                                                                                                                                                                                                                                                                                                        |
| BC<br>B.C.                                                 | Y                             | BC with or without periods.                                                                                                                                                                                                                                                                                                        |
| CC                                                         | N                             | Century<br>If the last two digits of the four digits year is 01~ 99, the value which is added by one to the first two digits is returned. (e.g. If the year is 2005, 21 is returned.)<br>If the last two digits of the four digits year is 00, the first two digits value is returned. (e.g. If the year is 2000, 20 is returned.) |
| D                                                          | Y                             | It returns the sequence of the day in a week. (1 ~ 7)<br>Sunday is 1, saturday is 7, and so on.                                                                                                                                                                                                                                    |
| DAY<br>Day<br>day                                          | Y                             | It returns the day of the week. (e.g. SUNDAY ) <ul style="list-style-type: none"> <li>• DAY: The day which is all in uppercase is returned.</li> <li>• Day: The day whose first character is uppercase and others are lowercase is returned.</li> <li>• day: The day which is all in lowercase is returned.</li> </ul>             |
| DD                                                         | Y                             | It returns the sequence of the day in a month. (1 ~ 31)                                                                                                                                                                                                                                                                            |
| DDD                                                        | Y                             | It returns the sequence of the day in a year. (1 ~ 366)                                                                                                                                                                                                                                                                            |

| Format element    | Whether to use T O_* datetime | Description                                                                                                                                                                                                                                                                                                                                                                                                                                                                               |
|-------------------|-------------------------------|-------------------------------------------------------------------------------------------------------------------------------------------------------------------------------------------------------------------------------------------------------------------------------------------------------------------------------------------------------------------------------------------------------------------------------------------------------------------------------------------|
| DY<br>Dy<br>dy    | Y                             | It returns the abbreviated word for the day of the week. (e.g. SUN) <ul style="list-style-type: none"> <li>DY: The day which is all in uppercase is returned.</li> <li>Dy: The day whose first character is uppercase and others are lowercase is returned.</li> <li>dy: The day which is all in lowercase is returned.</li> </ul>                                                                                                                                                        |
| FF[1..6]          | Y                             | It returns fractional seconds as many as the number of the specified digits (1-6) after FF.<br>If the number is not specified, the default value is 6. (FF is equal to FF6.)<br>If the number of fractional seconds digit is bigger than the number specified after FF, then it is rounded down.<br>If the number of fractional seconds digit is smaller than the number specified after FF, then zero(0) is added according to the specified number.<br>It can not be used in DATE type. |
| HH<br>HH12        | Y                             | The hour (1 ~ 12)                                                                                                                                                                                                                                                                                                                                                                                                                                                                         |
| HH24              | Y                             | The hour (0 ~ 23)                                                                                                                                                                                                                                                                                                                                                                                                                                                                         |
| IW                | N                             | The week containing the first thursday of the year designated as the calendar week by ISO 8601 standards (1 ~ 52 week or 1 ~ 53 weeks) becomes the first week. <ul style="list-style-type: none"> <li>The calendar week starts from monday.</li> <li>The first calendar week includes January 4th.</li> <li>The first calendar week may includes December 29th, 30th, and 31st.</li> <li>The last calendar week may include January 1st, 2nd, and 3rd.</li> </ul>                         |
| IYYY              | N                             | The 4 digits year embracing the calendar week defined by ISO 8601 standards                                                                                                                                                                                                                                                                                                                                                                                                               |
| IYY<br>IY<br>I    | N                             | The 3 digits year embracing the calendar week defined by ISO 8601 standards.<br>The 2 digits year embracing the calendar week defined by ISO 8601 standards.<br>The single digit year embracing the calendar week defined by ISO 8601 standards.                                                                                                                                                                                                                                          |
| J                 | Y                             | Julian day: The number of days since BC 4714-11-24                                                                                                                                                                                                                                                                                                                                                                                                                                        |
| MI                | Y                             | Minute (0 ~ 59)                                                                                                                                                                                                                                                                                                                                                                                                                                                                           |
| MM                | Y                             | Month (01 ~ 12), January(01)~December(12)                                                                                                                                                                                                                                                                                                                                                                                                                                                 |
| MON<br>Mon<br>mon | Y                             | The abbreviated word for the month. (e.g. JAN) <ul style="list-style-type: none"> <li>MON: The month which is all in uppercase is returned.</li> <li>Mon: The month whose first character is uppercase and others are lowercase is returned.</li> <li>mon: The month which is all in lowercase is returned.</li> </ul>                                                                                                                                                                    |
|                   |                               | The month name (e.g. JANUARY )                                                                                                                                                                                                                                                                                                                                                                                                                                                            |

| Format element          | Whether to use T O_* datetime | Description                                                                                                                                                                                                                                                                                                                                                                                                                                                                                                                                                                                                                                                                                                                                                                                                                                                                                                                                                                                                                                                                                                                                                                                                                                                                                                                                                                                    |
|-------------------------|-------------------------------|------------------------------------------------------------------------------------------------------------------------------------------------------------------------------------------------------------------------------------------------------------------------------------------------------------------------------------------------------------------------------------------------------------------------------------------------------------------------------------------------------------------------------------------------------------------------------------------------------------------------------------------------------------------------------------------------------------------------------------------------------------------------------------------------------------------------------------------------------------------------------------------------------------------------------------------------------------------------------------------------------------------------------------------------------------------------------------------------------------------------------------------------------------------------------------------------------------------------------------------------------------------------------------------------------------------------------------------------------------------------------------------------|
| MONTH<br>Month<br>month | Y                             | <ul style="list-style-type: none"> <li>MONTH: All uppercase month name is returned.</li> <li>Month: The month name that only the first letter is uppercase and others are lowercase is returned.</li> <li>month: The month of which is all in lowercase is returned.</li> </ul>                                                                                                                                                                                                                                                                                                                                                                                                                                                                                                                                                                                                                                                                                                                                                                                                                                                                                                                                                                                                                                                                                                                |
| PM<br>P.M.              | Y                             | PM with or without periods.                                                                                                                                                                                                                                                                                                                                                                                                                                                                                                                                                                                                                                                                                                                                                                                                                                                                                                                                                                                                                                                                                                                                                                                                                                                                                                                                                                    |
| Q                       | N                             | The quarter of the year (1 ~ 4)<br>January to March is 1 and October to December is 4.                                                                                                                                                                                                                                                                                                                                                                                                                                                                                                                                                                                                                                                                                                                                                                                                                                                                                                                                                                                                                                                                                                                                                                                                                                                                                                         |
| RM<br>Rm<br>rm          | Y                             | <p>It returns the roman numeral month. (e.g. I)</p> <ul style="list-style-type: none"> <li>RM: The month which is all in uppercase is returned.</li> <li>Rm: The month whose first character is uppercase and others are lowercase is returned.</li> <li>rm: The month which is all in lowercase is returned.</li> </ul>                                                                                                                                                                                                                                                                                                                                                                                                                                                                                                                                                                                                                                                                                                                                                                                                                                                                                                                                                                                                                                                                       |
| RR                      | Y                             | <p>Adjusted two digit year</p> <p>The two digit year represented by RR can be converted to four digit year as follows.</p> <ul style="list-style-type: none"> <li>When the two digit year represented by RR is 00~49: <ul style="list-style-type: none"> <li>If the last two digits of the current year is 00~50, <ul style="list-style-type: none"> <li>the four digit year is represented using the first two digits of the current year and the two digits which is represented by RR.</li> </ul> </li> <li>If the last two digits of the current year is 51~99, <ul style="list-style-type: none"> <li>the four digit year is represented using "the first two digits of the current year+1" and the two digits which is represented by RR.</li> </ul> </li> </ul> </li> <li>When the two digit year represented by RR is 50~99: <ul style="list-style-type: none"> <li>If the last two digits of the current year is 00~50, <ul style="list-style-type: none"> <li>the four digit year is represented using "the first two digit of the current year - 1" and the two digits which is represented by RR.</li> </ul> </li> <li>If the last two digit of the current year is 51~99, <ul style="list-style-type: none"> <li>the four digit year is expressed using the first two digit of the current year and the two digits which is represented by RR.</li> </ul> </li> </ul> </li> </ul> |
| RRRR                    | Y                             | <p>Adjusted four digit year</p> <p>Two digit or four digit can be input.</p> <p>Two digit input is processed in the same way as RR.</p>                                                                                                                                                                                                                                                                                                                                                                                                                                                                                                                                                                                                                                                                                                                                                                                                                                                                                                                                                                                                                                                                                                                                                                                                                                                        |
| SS                      | Y                             | Second (0 ~ 59)                                                                                                                                                                                                                                                                                                                                                                                                                                                                                                                                                                                                                                                                                                                                                                                                                                                                                                                                                                                                                                                                                                                                                                                                                                                                                                                                                                                |
| SSSS                    | Y                             | Seconds since last midnight (0 ~ 86399)                                                                                                                                                                                                                                                                                                                                                                                                                                                                                                                                                                                                                                                                                                                                                                                                                                                                                                                                                                                                                                                                                                                                                                                                                                                                                                                                                        |
| TZH                     | Y                             | <p>Time Zone Hour</p> <p>It can not be used in DATE, TIMESTAMP, TIME types. It is available in TIMESTAMP WITH TIME ZONE, TIME WITH TIME ZONE types.</p>                                                                                                                                                                                                                                                                                                                                                                                                                                                                                                                                                                                                                                                                                                                                                                                                                                                                                                                                                                                                                                                                                                                                                                                                                                        |



| Format element | Whether to use T O_* datetime | Description                                                                                                                                                                                                           |
|----------------|-------------------------------|-----------------------------------------------------------------------------------------------------------------------------------------------------------------------------------------------------------------------|
| TZM            | Y                             | Time Zone Minute<br>It can not be used in DATE, TIMESTAMP, TIME types. It can be used only in TIMESTAMP WITH TIME ZONE, TIME WITH TIME ZONE types.                                                                    |
| WW             | N                             | The sequence of the week in a year. (1~ 53)<br>The first week 1 starts on the first day of the year and continues to the seventh day of the year.                                                                     |
| W              | N                             | The sequence of the week in a month. (1 ~ 5)<br>The first week 1 starts on the first day of the month and ends on the seventh day.                                                                                    |
| Y,YYY          | Y                             | It returns the year with comma in the Y,YYY form.                                                                                                                                                                     |
| YYYY<br>SYYYY  | Y                             | Four digit year.<br>SYYYY displays the sign of year. <ul style="list-style-type: none"> <li>If it is BC, it displays '-'. If it is AD, it displays ' '.</li> </ul>                                                    |
| YYY<br>YY<br>Y | Y                             | <ul style="list-style-type: none"> <li>YYY: The last three digit year of the current year</li> <li>YY: The last two digit year of the current year</li> <li>Y: The last one digit year of the current year</li> </ul> |

The followings are examples of using datetime format string.

\* - / , . ; : "text" Special character

- TO\_CHAR( TO\_DATE( '2012-07-15 03:30:30', 'YYYY-MM-DD HH12:MI:SS' ), 'YYYY/MM/DD HH12:MI:SS' )  
=> '2012/07/15 03:30:30'
- TO\_CHAR( TO\_DATE( '2012-07-15', 'YYYY-MM-DD' ), 'YYYY"year" DDD"th day"' )  
=> '2012year 197th day'

\* AD

- TO\_CHAR( TO\_DATE( '2012-07-15 AD', 'YYYY-MM-DD AD' ), 'YYYY AD' )  
=> '2012 AD'
- TO\_CHAR( TO\_DATE( '0001-01-01 BC', 'YYYY-MM-DD AD'), 'YYYY AD' )  
=> '0001 BC'

\* BC

- TO\_CHAR( TO\_DATE( '0001-01-01 BC', 'YYYY-MM-DD BC'), 'YYYY BC' )  
=> '0001 BC'
- TO\_CHAR( TO\_DATE( '2012-07-15', 'YYYY-MM-DD' ), 'YYYY BC' )  
=> '2012 AD'

## \* AM

- `TO_CHAR( TO_DATE( '2012-07-15 03:30:30 AM',  
                  'YYYY-MM-DD HH12:MI:SS AM' ),  
          'HH12:MI:SS AM' )`  
==> '03:30:30 AM'
- `TO_CHAR( TO_DATE( '2012-07-15 21:30:30', 'YYYY-MM-DD HH24:MI:SS' ),  
          'HH12:MI:SS AM' )`  
==> '09:30:30 PM'

## \* PM

- `TO_CHAR( TO_DATE( '2012-07-15 03:30:30',  
                  'YYYY-MM-DD HH24:MI:SS' ),  
          'HH12:MI:SS PM' )`  
==> '03:30:30 AM'
- `TO_CHAR( TO_DATE( '2012-07-15 09:30:30 PM',  
                  'YYYY-MM-DD HH12:MI:SS PM' ),  
          'HH12:MI:SS PM' )`  
==> '09:30:30 PM'

## \* CC

- `TO_CHAR( TO_DATE( '2012-07-15', 'YYYY-MM-DD' ), 'CC' )`  
==> '21'

## \* D

- `TO_CHAR( TO_DATE( '2012-07-15', 'YYYY-MM-DD' ), 'D' )`  
==> '1'

## \* DD

- `TO_CHAR( TO_DATE( '2012-07-15', 'YYYY-MM-DD' ), 'DD' )`  
==> '15'

## \* DDD

- `TO_CHAR( TO_DATE( '2012-07-15', 'YYYY-MM-DD' ), 'DDD' )`  
==> '197'

## \* DAY

- `TO_CHAR( TO_DATE( '2012-07-15', 'YYYY-MM-DD' ), 'DAY' )`  
==> 'SUNDAY'
- `TO_CHAR( TO_DATE( '2012-07-15', 'YYYY-MM-DD' ), 'Day' )`  
==> 'Sunday'
- `TO_CHAR( TO_DATE( '2012-07-15', 'YYYY-MM-DD' ), 'day' )`  
==> 'sunday'

## \* DY

- `TO_CHAR( TO_DATE( '2012-07-15', 'YYYY-MM-DD' ), 'DY' )`

```
==> 'SUN'
```

- `TO_CHAR( TO_DATE( '2012-07-15', 'YYYY-MM-DD' ), 'Dy' )`  
==> 'Sun'
- `TO_CHAR( TO_DATE( '2012-07-15', 'YYYY-MM-DD' ), 'dy' )`  
==> 'sun'

#### \* FF[1 ... 6]

- `TO_CHAR( TO_TIMESTAMP( '2012-07-15 03:30:45.123456',  
                          'YYYY-MM-DD HH24:MI:SS.FF6' ),  
          'FF' )`  
==> '123456'
- `TO_CHAR( TO_TIMESTAMP( '2012-07-15 03:30:45.123456',  
                          'YYYY-MM-DD HH24:MI:SS.FF6' ),  
          'FF5' )`  
==> '12345'
- `TO_CHAR( TO_TIMESTAMP( '2012-07-15 03:30:45.9',  
                          'YYYY-MM-DD HH24:MI.SS.FF1' ) ,  
          'FF6' )`  
==> '9000000'

#### \* HH HH12 HH24

- `TO_CHAR( TO_TIMESTAMP( '2012-07-15 03:30:45.123456',  
                          'YYYY-MM-DD HH24:MI:SS.FF6' ),  
          'HH12' )`  
==> '03'
- `TO_CHAR( TO_TIMESTAMP( '2012-07-15 23:30:45.123456',  
                          'YYYY-MM-DD HH24:MI:SS.FF6' ),  
          'HH12' )`  
==> '11'
- `TO_CHAR( TO_TIMESTAMP( '2012-07-15 23:30:45.123456',  
                          'YYYY-MM-DD HH24:MI:SS.FF6' ),  
          'HH24' )`  
==> '23'

#### \* IW

- `TO_CHAR( DATE '2016-01-01', 'IW' )`  
==> 53
- `TO_CHAR( DATE '2014-12-30', 'IW' )`  
==> 01

**\* IYYY**

- TO\_CHAR( DATE'2016-01-01', 'IYYY' )  
==> 2015
- TO\_CHAR( DATE'2014-12-30', 'IYYY' )  
==> 2015

**\* IYY**

- TO\_CHAR( DATE'2016-01-01', 'IYY' )  
==> 015

**\* IY**

- TO\_CHAR( DATE'2016-01-01', 'IY' )  
==> 15

**\* I**

- TO\_CHAR( DATE'2016-01-01', 'I' )  
==> 5

**\* J**

- TO\_CHAR( TO\_DATE( '2012-07-15', 'YYYY-MM-DD' ), 'J' )  
==> '2456124'
- TO\_CHAR( TO\_DATE( '2456124', 'J' ), 'YYYY-MM-DD' )  
==> '2012-07-15'

**\* MI**

- TO\_CHAR( TO\_TIMESTAMP( '2012-07-15 23:30:45.123456',  
                          'YYYY-MM-DD HH24:MI:SS.FF6' ),  
          'MI' )  
==> '30'

**\* MM**

- TO\_CHAR( TO\_TIMESTAMP( '2012-07-15 23:30:45.123456',  
                          'YYYY-MM-DD HH24:MI:SS.FF6' ),  
          'MM' )  
==> '07'

**\* MON**

- TO\_CHAR( TO\_DATE( '2012-07-15', 'YYYY-MM-DD' ), 'MON' )  
==> 'JUL'
- TO\_CHAR( TO\_DATE( '2012-07-15', 'YYYY-MM-DD' ), 'Mon' )  
==> 'Jul'
- TO\_CHAR( TO\_DATE( '2012-07-15', 'YYYY-MM-DD' ), 'mon' )  
==> 'jul'

**\* MONTH**

- `TO_CHAR( TO_DATE( '2012-07-15', 'YYYY-MM-DD' ), 'MONTH' )`  
=> 'JULY'
- `TO_CHAR( TO_DATE( '2012-07-15', 'YYYY-MM-DD' ), 'Month' )`  
=> 'July'
- `TO_CHAR( TO_DATE( '2012-07-15', 'YYYY-MM-DD' ), 'month' )`  
=> 'july'

## \* Q

- `TO_CHAR( TO_DATE( '2012-07-15', 'YYYY-MM-DD' ), 'Q' )`  
=> '3'

## \* RM

- `TO_CHAR( TO_DATE( '2012-07-15', 'YYYY-MM-DD' ), 'RM' )`  
=> 'VII'
- `TO_CHAR( TO_DATE( '2012-07-15', 'YYYY-MM-DD' ), 'Rm' )`  
=> 'Vii'
- `TO_CHAR( TO_DATE( '2012-07-15', 'YYYY-MM-DD' ), 'rm' )`  
=> 'vii'

## \* RR, RRRR ( The current year is 2014. )

- `TO_CHAR( TO_DATE( '49-07-15', 'RR-MM-DD' ), 'RRRR' )`  
=> '2049'
- `TO_CHAR( TO_DATE( '49-07-15', 'RR-MM-DD' ), 'YYYY' )`  
=> '2049'
- `TO_CHAR( TO_DATE( '50-07-15', 'RR-MM-DD' ), 'RRRR' )`  
=> '1950'
- `TO_CHAR( TO_DATE( '50-07-15', 'RR-MM-DD' ), 'YYYY' )`  
=> '1950'
- `TO_CHAR( TO_DATE( '50-07-15', 'YY-MM-DD' ), 'RRRR' )`  
=> '2050'
- `TO_CHAR( TO_DATE( '49-07-15', 'RRRR-MM-DD' ), 'YYYY' )`  
=> '2049'
- `TO_CHAR( TO_DATE( '50-07-15', 'RRRR-MM-DD' ), 'YYYY' )`  
=> '1950'

## \* RR, RRRR ( The current year is 2051. )

- `TO_CHAR( TO_DATE( '49-07-15', 'RR-MM-DD' ), 'RRRR' )`  
=> '2149'
- `TO_CHAR( TO_DATE( '49-07-15', 'RR-MM-DD' ), 'YYYY' )`  
=> '2149'
- `TO_CHAR( TO_DATE( '50-07-15', 'RR-MM-DD' ), 'RRRR' )`  
=> '2050'

- `TO_CHAR( TO_DATE( '50-07-15', 'RR-MM-DD' ), 'YYYY' )`  
=> '2050'
- `TO_CHAR( TO_DATE( '50-07-15', 'YY-MM-DD' ), 'RRRR' )`  
=> '2050'
- `TO_CHAR( TO_DATE( '49-07-15', 'RRRR-MM-DD' ), 'YYYY' )`  
=> '2149'
- `TO_CHAR( TO_DATE( '50-07-15', 'RRRR-MM-DD' ), 'YYYY' )`  
=> '2050'

## \* SS

- `TO_CHAR( TO_TIMESTAMP( '2012-07-15 23:30:45.123456',  
                          'YYYY-MM-DD HH24:MI:SS.FF6' ),  
                          'SS' )`  
=> '45'

## \* SSSSS

- `TO_CHAR( TO_TIMESTAMP( '2012-07-15 23:30:45.123456',  
                          'YYYY-MM-DD HH24:MI:SS.FF6' ),  
                          'SSSSS' )`  
=> '84645'

## \* TZH

- `TO_CHAR( TO_TIMESTAMP_TZ( '2012-07-15 23:30:45.123456 +09:00',  
                              'YYYY-MM-DD HH24:MI:SS.FF6 TZH:TZM' ),  
                              'TZH' )`  
=> '+09'

## \* TZM

- `TO_CHAR( TO_TIMESTAMP_TZ( '2012-07-15 23:30:45.123456 +09:00',  
                              'YYYY-MM-DD HH24:MI:SS.FF6 TZH:TZM' ),  
                              'TZM' )`  
=> '00'
- `TO_CHAR( TO_TIMESTAMP_TZ( '2012-07-15 23:30:45.123456 +09:00',  
                              'YYYY-MM-DD HH24:MI:SS.FF6 TZH:TZM' ),  
                              'TZH:TZM' )`  
=> '+09:00'

## \* WW

- `TO_CHAR( TO_DATE( '2012-07-15', 'YYYY-MM-DD' ), 'WW' )`  
=> '29'

## \* W

- `TO_CHAR( TO_DATE( '2012-07-15', 'YYYY-MM-DD' ), 'W' )`  
=> '3'

```

* Y,YYY
  • TO_CHAR( TO_DATE( '2,012-07-15', 'Y,YYY-MM-DD' ), 'Y,YYY' )
    ==> '2,012'

* YYYY
  • TO_CHAR( TO_DATE( '2012-07-15', 'YYYY-MM-DD' ), 'YYYY' )
    ==> '2012'

* SYYYY
  • TO_CHAR( TO_DATE( '-0001-01-01', 'SYYYY-MM-DD' ), 'SYYYY' )
    ==> '-0001'
  • TO_CHAR( TO_DATE( '2000-01-01', 'SYYYY-MM-DD' ), 'SYYYY' )
    ==> ' 2000'

* YYY
  • TO_CHAR( TO_DATE( '012-07-15', 'YYY-MM-DD' ), 'YYY' )
    ==> '012'
  • TO_CHAR( TO_DATE( '012-07-15', 'YYY-MM-DD' ), 'YYYY' )
    ==> '2012' ( (Current year / 1000) is 2 )

* YY
  • TO_CHAR( TO_DATE( '12-07-15', 'YY-MM-DD' ), 'YY' )
    ==> '12'
  • TO_CHAR( TO_DATE( '12-07-15', 'YY-MM-DD' ), 'YYYY' )
    ==> '2012' ( (Current year / 100) is 20 )
    ==> '2112' ( (Current year / 100) is 21 )

* Y
  • TO_CHAR( TO_DATE( '2-07-15', 'Y-MM-DD' ), 'Y' )
    ==> '2'
  • TO_CHAR( TO_DATE( '12-07-15', 'YY-MM-DD' ), 'YYYY' )
    ==> '2012' ( (Current year / 10 years) is 201 )
    ==> '2052' ( (Current year / 10 years) is 205 )

```

## 11.4 Expressions

Expression is a combination of value, operator and function for getting data values.

The following is the position of the SQL commands in which expression can be used.

- Target clause in SELECT
- GROUP BY clause in SELECT
- ORDER BY clause in SELECT
- WHERE clause and HAVING clause in SELECT
- INSERT VALUES clause
- UPDATE SET clause
- RETURN clause in INSERT, DELETE, UPDATE

Expression types are various as follows.

- Simple expression
- Compound expression
- Boolean value expression
- Case expression
- Datetime expression
- Scalar subquery expression
- Sequence manipulation expression

Simple expressions are column, pseudo columns, literals, and null value.

Compound expressions are combination of multiple expressions.

For more information, refer to the followings.

- **Null Value**
- **Literals**
- **Pseudo Columns**
- **Operators**
- **Functions**

### Boolean Value Expression

#### Syntax

```
<boolean value expression> ::=  
    <boolean term>  
    | <boolean value expression> OR <boolean term>
```



```

<boolean term> ::=
    <boolean factor>
    | <boolean term> AND <boolean factor>
<boolean factor> ::=
    [ NOT ] <boolean test>
<boolean test> ::=
    <boolean primary> [ IS [ NOT ] <truth value> ]
<truth value> ::=
    TRUE
    | FALSE
    | UNKNOWN
<boolean primary> ::=
    <column>
    <condition>
    | <boolean predicand>
<boolean predicand> ::=
    <parenthesized boolean value expression>
    | <nonparenthesized value expression primary>
<parenthesized boolean value expression> ::=
    <left paren> <boolean value expression> <right paren>

```

## Description

<boolean value expression> describes a boolean value. <boolean primary> with boolean value are <column>, <condition>, and <boolean predicand>. <column> should be declared as BOOLEAN type, and it is allowed to return a boolean value using CAST.

<boolean value expression> can use logical operators such as AND, OR, NOT, and the dedicated operators of boolean value such as IS, IS NOT are also supported.

IS operator and IS NOT operator which are described in <boolean test> determine whether the boolean value described in <boolean primary> matches with one of the <truth value> (TRUE, FALSE, UNKNOWN).

For more information, refer to **Conditions**.

## Example

```

gSQL> SELECT * FROM T1 WHERE CAST('TRUE' AS BOOLEAN);
I1
-----
TRUE

```

```

FALSE
null
3 rows selected.
gSQL> SELECT * FROM T1 WHERE I1;
I1
----
TRUE
1 row selected.
gSQL> SELECT * FROM T1 WHERE I1 IS TRUE;
I1
----
TRUE
1 row selected.
gSQL> SELECT * FROM T1 WHERE I1 IS NOT FALSE;
I1
----
TRUE
null
2 rows selected.
gSQL> SELECT * FROM T1 WHERE I1 IS UNKNOWN;
I1
----
null
1 row selected.

```

## CASE Expression

### Syntax

```

<case expression> ::=
    <simple case>
  | <searched case>
<simple case> ::=
    CASE expr WHEN comparison_expr THEN result
      [ WHEN comparison_expr THEN result ... ]
      [ ELSE result ]
    END
<searched case> ::=
    CASE WHEN condition THEN result

```

```

        [ WHEN condition THEN result ... ]
        [ ELSE result ]
END

```

## Description

WHEN ... THEN clause is evaluated in the order of which is described in the CASE statement.

If a comparison result is FALSE, the subsequent WHEN ... THEN clauses are evaluated until TRUE comes up.

If a comparison result is TRUE, the result is returned, and the evaluation is not executed any more.

- Simple case

The comparison\_expr of CASE expr and WHEN ... THEN clause is evaluated as the equal operation. (expr = comparison\_expr).

- Searched case

The condition of WHEN ... THEN clause is evaluated.

If all evaluation results of the WHEN clause are FALSE, then result of ELSE clause is returned.

If ELSE clause is omitted, NULL is returned as a result.

If there are multiple types of THEN or ELSE clause results, the result type is determined by **Result Type Combination Rule**.

For more information, refer to the followings.

- COALESCE
- NULLIF

## Example

- Simple case.

```

gSQL> SELECT I1,
           CASE I1 WHEN 1 THEN 'ONE'
                 WHEN 2 THEN 'TWO'
                 ELSE 'NUMBER'
           END AS CASE_RESULT1,
           CASE I1 WHEN 1 THEN 'ONE'
                 WHEN 2 THEN 'TWO'
           END AS CASE_RESULT2
FROM T1;
I1 CASE_RESULT1 CASE_RESULT2

```

```

-----
1 ONE          ONE
2 TWO          TWO
3 NUMBER       null
3 rows selected.

```

- Searched case.

```

gSQL> SELECT I1,
           CASE WHEN I1 = 1 THEN 'ONE'
                WHEN I1 = 2 THEN 'TWO'
                ELSE 'NUMBER'
           END AS CASE_RESULT1,
           CASE WHEN I1 = 1 THEN 'ONE'
                WHEN I1 = 2 THEN 'TWO'
           END AS CASE_RESULT2
FROM T1;
I1 CASE_RESULT1 CASE_RESULT2
-----
1 ONE          ONE
2 TWO          TWO
3 NUMBER       null
3 rows selected.

```

## CAST Specification

### Syntax

```
CAST( expression AS data_type )
```

### Description

CAST converts the expression data type to the data type of the specified data\_type.

### Example

```

gSQL> SELECT CAST( '1-2' AS INTERVAL YEAR TO MONTH ) AS RESULT FROM DUAL;
RESULT
-----

```

```
+01-02
```

```
1 row selected.
```

## Scalar Subquery Expression

Scalar subquery expression is a subquery which returns a single row with one column as a result. The scalar subquery expression result is the values described in select list of the subquery.

If the subquery does not return any row, then the result value is NULL, and if it returns two or more rows, then an error occurs.

Scalar subquery expression can be described on most position which describes expression. The subquery should be enclosed in parentheses. Even when scalar subquery expression is used as a function argument and the scalar subquery expression is enclosed in parentheses, other parentheses for the subquery is required regardless of the function parentheses. Otherwise, an error occurs.

The following is an example of using scalar subquery expression.

```
gSQL> select * from dual where dummy = (select * from dual);
DUMMY
-----
X
1 row selected.
gSQL> select sum(select 1 from dual) from dual;
ERR-42000(40000): syntax error
select sum(select 1 from dual) from dual
.....^    ^
Error at line 1
gSQL> select sum((select 1 from dual)) from dual;
SUM((SELECT 1 FROM DUAL))
-----
1
1 row selected.
```

## Compatibility

The SQL standard compatibility for expression is as follows.

**Table 11-28** SQL standard compatibility for expression

| Feature ID | Description                                                                         | Availability |
|------------|-------------------------------------------------------------------------------------|--------------|
| E121-03    | Value expressions in ORDER BY clause                                                | O            |
| F051-05    | Basic date and time Explicit CAST between datetime types and character string types | O            |
| F201       | CAST function                                                                       | O            |
| F261-01    | Simple CASE                                                                         | O            |
| F261-02    | Searched CASE                                                                       | O            |
| F261-03    | NULLIF                                                                              | O            |
| F261-04    | COALESCE                                                                            | O            |
| F263       | Comma-separated predicates in simple CASE expression                                | X            |
| F301       | CORRESPONDING in query expressions                                                  | X            |
| F385       | Drop column generation expression clause                                            | X            |
| F561       | Full value expressions                                                              | X            |
| F846       | Octet support in regular expression operators                                       | X            |
| F847       | Nonconstant regular expressions                                                     | X            |
| F850       | Top-level <order by clause> in <query expression>                                   | O            |
| F855       | Nested <order by clause> in <query expression>                                      | O            |
| F856       | Nested <fetch first clause> in <query expression>                                   | O            |
| F857       | Top-level <fetch first clause> in <query expression>                                | O            |
| F861       | Top-level <result offset clause> in <query expression>                              | O            |
| F863       | Nested <result offset clause> in <query expression>                                 | O            |
| S091-03    | Arrays expressions                                                                  | X            |
| S111       | ONLY in query expressions                                                           | X            |
| T121       | WITH (excluding RECURSIVE) in query expression                                      | O            |
| T581       | Regular expression substring function                                               | X            |

## 11.5 Pseudo Columns

Pseudo column is not only similar to function, but also it is similar to table column because it can return different value in row unit every time the pseudo column is executed.

**Table 11-29** Supported pseudo column

| Name                | Description                                                     | Refer to                          |
|---------------------|-----------------------------------------------------------------|-----------------------------------|
| CURRVAL             | It is a pseudo column which is related to a sequence.           | CURRVAL                           |
| NEXTVAL             | It is a pseudo column which is related to a sequence.           | ROWID Pseudo Column               |
| ROWNUM              | It is the row number which satisfies the condition.             | ROWNUM                            |
| ROWID               | It returns the record identifier in database.                   | ROWID Pseudo Column               |
| CLUSTER_GROUP_ID    | It returns the group identifier in database.                    | CLUSTER_GROUP_ID Pseudo Column    |
| CLUSTER_MEMBER_ID   | It returns the member identifier in which the record is stored. | CLUSTER_MEMBER_ID Pseudo Column   |
| CLUSTER_GROUP_NAME  | It returns the group name in which the record is stored.        | CLUSTER_GROUP_NAME Pseudo Column  |
| CLUSTER_MEMBER_NAME | It returns the member name in which the record is stored.       | CLUSTER_MEMBER_NAME Pseudo Column |
| CLUSTER_SHARD_ID    | It returns the shard identifier in which the record is stored.  | CLUSTER_SHARD_ID Pseudo Column    |

### ROWID Pseudo Column

ROWID pseudo column is a record identifier, and it returns the identification information of each database record.

ROWID has the following information to identify the location within the database depending on the system.

Standalone system

- OBJECT\_ID
- TABLESPACE\_ID
- PAGE\_ID
- OFFSET in PAGE

Cluster system

- GRID\_BLOCK\_SEQUENCE
- GRID\_BLOCK\_ID
- MEMBER\_ID
- SHARD\_ID

The information stored inside in base 64 encoding is converted into the value such as A-Z, a-z, 0-9, +, / then output when querying ROWID.

Each information to identify the address within database stored in ROWID can be obtained using the ROWID-related functions.

The address of the deleted record can be newly reassigned to the record to be inserted.

ROWID pseudo column can be used only in SELECT operation, but it can not be used in INSERT, UPDATE, DELETE operations.

For more information, refer to **ROWID, ROWID-related Functions**.

The following is an example of querying ROWID pseudo column.

```
gSQL> SELECT ROWID FROM T1;
                ROWID
-----
AAAAAAAAAFpEAACAAAEkAAA
AAAAAAAAAFpEAACAAAEkAAB
AAAAAAAAAFpEAACAAAEkAAC
AAAAAAAAAFpEAACAAAEkAAD
AAAAAAAAAFpEAACAAAEkAAE
5 rows selected.
```

## CLUSTER\_GROUP\_ID Pseudo Column

CLUSTER\_GROUP\_ID pseudo column returns the group identifier of a server in which the record is stored.

CLUSTER\_GROUP\_ID pseudo column can perform the SELECT, but it can not perform the INSERT, UPDATE, or DELETE.



This information is valid in the cluster system.

The following is an example of retrieving CLUSTER\_GROUP\_ID pseudo column.



```
gSQL> SELECT T1.C1, T1.CLUSTER_GROUP_ID FROM T1;
C1 T1.CLUSTER_GROUP_ID
-- -----
A          1
B          2
C          3
3 rows selected.
```

## CLUSTER\_MEMBER\_ID Pseudo Column

CLUSTER\_MEMBER\_ID pseudo column returns the member identifier of a server in which the record is stored.

CLUSTER\_MEMBER\_ID pseudo column can perform the SELECT, but it can not perform the INSERT, UPDATE, or DELETE.



This information is valid in the cluster system.

The following is an example of retrieving CLUSTER\_MEMBER\_ID pseudo column.

```
gSQL> SELECT T1.C1, T1.CLUSTER_MEMBER_ID FROM T1;
C1 T1.CLUSTER_MEMBER_ID
-- -----
A          1
B          3
C          5
3 rows selected.
```

## CLUSTER\_GROUP\_NAME Pseudo Column

CLUSTER\_GROUP\_NAME pseudo column returns the group name of a server in which the record is stored.

CLUSTER\_GROUP\_NAME pseudo column can perform the SELECT, but it can not perform the INSERT, UPDATE, or DELETE.



This information is valid in the cluster system.

The following is an example of retrieving CLUSTER\_GROUP\_NAME pseudo column.

```
gSQL> SELECT T1.C1, T1.CLUSTER_GROUP_NAME FROM T1;
C1 T1.CLUSTER_GROUP_NAME
-- -----
A  G1
B  G2
C  G3
3 rows selected.
```

## CLUSTER\_MEMBER\_NAME Pseudo Column

CLUSTER\_MEMBER\_NAME pseudo column returns the member name of a server in which the record is stored.

CLUSTER\_MEMBER\_NAME pseudo column can perform the SELECT, but it can not perform the INSERT, UPDATE, or DELETE.



This information is valid in the cluster system.

The following is an example of retrieving CLUSTER\_MEMBER\_NAME pseudo column.

```
gSQL> SELECT T1.C1, T1.CLUSTER_MEMBER_NAME FROM T1;
C1 T1.CLUSTER_MEMBER_NAME
-- -----
A  G1N1
B  G2N1
C  G3N1
3 rows selected.
```

## CLUSTER\_SHARD\_ID Pseudo Column

CLUSTER\_SHARD\_ID pseudo column returns the shard identifier in which the record is stored.

CLUSTER\_SHARD\_ID pseudo column is allowed for SELECT only, but it is not allowed for INSERT, UPDATE, or DELETE.



This information is valid in the cluster system.

The following is an example of retrieving CLUSTER\_SHARD\_ID pseudo column.

```
gSQL> SELECT T1.C1, T1.CLUSTER_SHARD_ID FROM T1;
C1 CLUSTER_SHARD_ID
-- -----
A          14
B          17
C           4
3 rows selected.
```

## Compatibility

The SQL standard compatibility for pseudo column is as follows.

**Table 11-30** SQL standard compatibility for pseudo column

| Feature ID | Description                                       | Availability |
|------------|---------------------------------------------------|--------------|
| T176       | Sequence generator support                        | O            |
| T177       | Sequence generator support: simple restart option | O            |

## 11.6 Operators

An operator is represented by one or more specific symbols or keywords, and it performs an operation using one or more arguments.

The operator types are various as follows.

- Arithmetic operator
- Concatenation operator
- Set operator

### Arithmetic Operator

#### Syntax

```
<arithmetic operator> ::=
    <value term>
    | <expression> + <value term>
    | <expression> - <value term>
<value term> ::=
    <value factor>
    | <value term> * <value factor>
    | <value term> / <value factor>
<value factor> ::=
    <expression>
    | + <expression>
    | - <expression>
```

#### Description

An arithmetic operator performs an arithmetic operation of the numeric types, date/time types or interval types.

The arithmetic operator precedence is as follows.

1. + (POSITIVE), - (NEGATIVE)
2. \* (MULTIPLICATION), / (DIVISION)
3. + (ADDITION), - (SUBTRACTION)

# Concatenation Operator

## Syntax

```
<concatenation operator> ::=
    <expression> || <expression>
```

## Description

A concatenation operator returns strings which connect between values of CHARACTER STRING type or BINARY STRING type.

For more information, refer to **|| (CONCATENATE), CONCATENATE**.

# Set Operator

## Syntax

```
<set operator> ::=
    <set operator term>
    | <subquery> UNION [ ALL | DISTINCT ] <set operator term>
    | <subquery> EXCEPT [ ALL | DISTINCT ] <set operator term>
    | <subquery> MINUS [ ALL | DISTINCT ] <set operator term>
<set operator term> ::=
    <subquery>
    | <subquery> INTERSECT [ ALL | DISTINCT ] <set operator term>
```

## Description

**set operator** performs a set operation of the subquery results.

INTERSECT ALL/DISTINCT has a higher precedence than other set operators.

**Table 11-31** Set operators

| Operator        | Description                                                                             |
|-----------------|-----------------------------------------------------------------------------------------|
| UNION ALL       | It is the union which does not exclude duplicated rows of the subquery result.          |
| UNION DISTINCT  | It is the union which excludes duplicated rows of the subquery result.                  |
| EXCEPT ALL      | It is the difference set which does not exclude duplicated rows of the subquery result. |
| EXCEPT DISTINCT | It is the difference set which excludes duplicated rows of the subquery result.         |

| Operator           | Description                                                                           |
|--------------------|---------------------------------------------------------------------------------------|
| MINUS ALL          | It is as same as EXCEPT ALL.                                                          |
| MINUS DISTINCT     | It is as same as EXCEPT DISTINCT.                                                     |
| INTERSECT ALL      | It is the intersection which does not exclude duplicated rows of the subquery result. |
| INTERSECT DISTINCT | It is the intersection which excludes duplicated rows of the subquery result.         |

## Compatibility

The SQL standard compatibility for operator is as follows.

**Table 11-32** SQL standard compatibility for operator

| Feature ID | Description                                                                   | Availability |
|------------|-------------------------------------------------------------------------------|--------------|
| E011-04    | Arithmetic operators                                                          | O            |
| E021-07    | Character concatenation                                                       | O            |
| E071-01    | UNION DISTINCT table operator                                                 | O            |
| E071-02    | UNION ALL table operator                                                      | O            |
| E071-03    | EXCEPT DISTINCT table operator                                                | O            |
| E071-05    | Columns combined via table operators need not have exactly the same data type | O            |
| E071-06    | Table operators in subqueries                                                 | O            |
| F041-08    | All comparison operators are supported (rather than just =)                   | O            |
| F302-01    | INTERSECT DISTINCT table operator                                             | O            |
| F302-02    | INTERSECT ALL table operator                                                  | O            |
| F304       | EXCEPT ALL table operator                                                     | O            |
| F846       | Octet support in regular expression operators                                 | X            |
| J571       | NEW operator                                                                  | X            |

## 11.7 Functions

Functions and operators are similar in features. However, to represent arguments, functions use parentheses after its name. A function can have zero or more arguments.

The function has two types as follows.

- Single row function
- Aggregate function

### Single Row Function

Single row function creates a single result row for each row in the table or view.

The single row functions are as follows.

- Numeric function
- Character string function returning character values
- Character string function returning number values
- Datetime function
- General comparison function
- Conversion function
- Conditional function
- NULL-related function
- ROWID-related function
- Encryption function
- System information function

### Numeric Functions

A numeric value is input in numeric function, and the numeric function returns a numeric result.

For more information about the numeric function types, refer to the followings.

- **ABS**
- **ACOS**
- **ASIN**
- **ATAN**
- **ATAN2**
- **BITAND**

- BITNOT
- BITOR
- BITXOR
- CBRT
- CEIL
- COS
- COT
- DEGREES
- EXP
- FACTORIAL
- FLOOR
- LN
- LOG
- MOD
- PI
- POWER
- RADIANS
- RANDOM
- ROUND( number )
- SHARD\_ID
- SHIFT\_LEFT
- SHIFT\_RIGHT
- SIGN
- SIN
- SQRT
- TAN
- TRUNC( number )
- WIDTH\_BUCKET

## Character String Functions Returning Character Values

A character string type value is input in character string functions returning character values, and the function returns the result of character string type.

For more information about character string functions returning character values types, refer to the following.

- CHR
- CONCAT
- CONCATENATE
- INITCAP
- LOWER



- LPAD
- LTRIM
- OVERLAY
- REPEAT
- REPLACE
- REVERSE
- RPAD
- RTRIM
- SPLIT\_PART
- SUBSTR
- SUBSTRB
- TRANSLATE
- TRIM
- UPPER

## Character String Functions Returning Number Values

A character string type value is input in character string functions returning number values the value, and the function returns the result of number type.

For more information about character string functions returning number values types, refer to the followings.

- ASCII
- BIT\_LENGTH
- BYTE\_LENGTH
- CHAR\_LENGTH
- INSTR
- LENGTH
- LENGTHB
- OCTET\_LENGTH
- POSITION

## Datetime Functions

The value of date/time/timestamp/interval type is input in datetime function, and the function returns the result of date/time/timestamp/interval type.

For more information about datetime functions types, refer to the followings.

- ADDDATE
- ADDTIME

- ADD\_MONTHS
- DATEADD
- DATEDIFF
- DATE\_ADD
- DATE\_PART
- EXTRACT
- FROM\_TZ
- LAST\_DAY
- MONTHS\_BETWEEN

## General Comparison Functions

General comparison function returns a minimum value or a maximum value for the value set.

For more information about general comparison function types, refer to the followings.

- GREATEST
- LEAST

## Conversion Functions

Conversion function sets the value of a particular data type.

For more information about conversion function types, refer to the followings.

- NUMTODSINTERVAL
- NUMTOYMINTERVAL
- TO\_CHAR( datetime )
- TO\_CHAR( number )
- TO\_DATE
- TO\_NATIVE\_BIGINT
- TO\_NATIVE\_DOUBLE
- TO\_NATIVE\_INTEGER
- TO\_NATIVE\_REAL
- TO\_NATIVE\_SMALLINT
- TO\_NUMBER
- TO\_TIME
- TO\_TIME\_TZ
- TO\_TIME\_WITH\_TIME\_ZONE
- TO\_TIMESTAMP
- TO\_TIMESTAMP\_TZ
- TO\_TIMESTAMP\_WITH\_TIME\_ZONE

## Conditional Functions

Conditional function returns a result of specific value depending on a condition.

For more information about conditional function types, refer to the followings.

- CASE2
- DECODE

## NULL-related Functions

NULL-related function returns a result of specific value depending on whether the input value is a NULL value.

For more information about null-related function types, refer to the followings.

- COALESCE
- NULLIF
- NVL
- NVL2

## ROWID-related Functions

ROWID-related function is used to obtain information about the ROWID.

For more information about ROWID-related function types, refer to the followings.

- Valid functions in stand-alone
  - ROWID\_OBJECT\_ID
  - ROWID\_TABLESPACE\_ID
  - ROWID\_PAGE\_ID
  - ROWID\_ROW\_NUMBER
- Valid functions in cluster
  - ROWID\_GRID\_BLOCK\_ID
  - ROWID\_GRID\_BLOCK\_SEQ
  - ROWID\_MEMBER\_ID
  - ROWID\_SHARD\_ID

## Encryption Functions

encryption function encrypts, decrypts, or hashes the given plain text by using the specific algorithm, then returns the result.

For more information about the encryption function, refer to **DIGEST**.

## System Information Functions

System information function is used to obtain information about sessions and the system.

For more information about system information function type, refer to the followings.

- 17.29 CLOCK\_DATE
- CLOCK\_LOCALTIME
- CLOCK\_LOCALTIMESTAMP
- CURRENT\_CATALOG
- CURRENT\_DATE
- CURRENT\_SCHEMA
- CURRENT\_TIME
- CURRENT\_TIMESTAMP
- CURRENT\_USER
- LAST\_IDENTITY\_VALUE
- LOCALTIME
- LOCALTIMESTAMP
- LOGON\_USER
- SESSION\_ID
- SESSION\_SERIAL
- SESSION\_USER
- STATEMENT\_DATE
- STATEMENT\_LOCALTIME
- STATEMENT\_LOCALTIMESTAMP
- STATEMENT\_TIME
- STATEMENT\_TIMESTAMP
- STATEMENT\_VIEW\_SCN
- SYSDATE
- SYSTIME
- SYSTIMESTAMP
- TRANSACTION\_DATE
- TRANSACTION\_LOCALTIME
- TRANSACTION\_LOCALTIMESTAMP
- TRANSACTION\_TIME
- TRANSACTION\_TIMESTAMP
- USER\_ID
- VERSION

## Aggregate Function

Aggregate function creates a single result row for multiple rows.

For more information about aggregate function types, refer to the followings.

- COUNT
- COUNT(\*)
- SUM
- AVG
- MIN
- MAX
- STDDEV
- STDDEV\_POP
- STDDEV\_SAMP
- VAR\_POP
- VAR\_SAMP
- VARIANCE

## Compatibility

The SQL standard compatibility for function is as follows.

**Table 11-33** SQL standard compatibility for function

| Feature ID | Description                            | Availability |
|------------|----------------------------------------|--------------|
| B033       | Untyped SQL-invoked function arguments | X            |
| E021-04    | CHARACTER_LENGTH function              | O            |
| E021-05    | OCTET_LENGTH function                  | O            |
| E021-06    | SUBSTRING function                     | O            |
| E021-08    | UPPER and LOWER functions              | O            |
| E021-09    | TRIM function                          | O            |
| E021-11    | POSITION function                      | O            |
| E091-01    | AVG                                    | O            |
| E091-02    | COUNT                                  | O            |
| E091-03    | MAX                                    | O            |
| E091-04    | MIN                                    | O            |
| E091-05    | SUM                                    | O            |
| E091-06    | ALL quantifier                         | O            |
| E091-07    | DISTINCT quantifier                    | O            |

| Feature ID | Description                                                                      | Availability |
|------------|----------------------------------------------------------------------------------|--------------|
| F131-03    | Set functions supported in queries with grouped views                            | O            |
| F201       | CAST function                                                                    | O            |
| F441       | Extended set function support                                                    | O            |
| F442       | Mixed column references in set functions                                         | X            |
| F801       | Full set function                                                                | X            |
| F842       | OCCURRENCES_REGEX function                                                       | X            |
| F843       | POSITION_REGEX function                                                          | X            |
| S071       | SQL paths in function and type name resolution                                   | X            |
| S201-02    | Array as result type of functions                                                | X            |
| S211       | User-defined cast functions                                                      | X            |
| S241       | Transform functions                                                              | X            |
| T041-03    | POSITION, LENGTH, LOWER, TRIM, UPPER, and SUBSTRING functions for LOB data types | X            |
| T312       | OVERLAY function                                                                 | O            |
| T321-01    | User-defined functions with no overloading                                       | O            |
| T326       | Table functions                                                                  | X            |
| T341       | Overloading of SQL-invoked functions and SQL-invoked procedures                  | X            |
| T433       | Multiargument GROUPING function                                                  | X            |
| T441       | ABS and MOD functions                                                            | O            |
| T571       | Array-returning external SQL-invoked functions                                   | X            |
| T572       | Multiset-returning external SQL-invoked functions                                | X            |
| T581       | Regular expression substring function                                            | X            |
| T614       | NTILE function                                                                   | X            |
| T615       | LEAD and LAG functions                                                           | X            |
| T616       | Null treatment option for LEAD and LAG functions                                 | X            |
| T617       | FIRST_VALUE and LAST_VALUE functions                                             | X            |
| T618       | NTH_VALUE function                                                               | X            |
| T619       | Nested window functions                                                          | X            |
| T621       | Enhanced numeric functions                                                       | O            |

## 11.8 Conditions

### Condition

Condition is an expression which is evaluated as TRUE, FALSE, UNKNOWN.

Condition can be used in the following SQL statements.

- WHERE clauses in DELETE, UPDATE statements
- WHERE and HAVING clauses in SELECT statement
- Where the BOOLEAN TYPE can be used

The condition types are as follows.

- Comparison condition
- Logical condition
- Null condition
- Compound condition
- Pattern-matching condition
- Between condition
- In condition
- Exists condition

**Table 11-34** Condition precedence

| Precedence | Condition type                                                |
|------------|---------------------------------------------------------------|
| 1          | Operators in condition clauses                                |
| 2          | =, !=, <, >, <=, >=                                           |
| 3          | IS [NOT] NULL,<br>[NOT] BETWEEN,<br>[NOT] IN,<br>LIKE, EXISTS |
| 4          | NOT                                                           |
| 5          | AND                                                           |
| 6          | OR                                                            |

### Comparison Conditions

It compares both conditional expressions, and returns the boolean type of TRUE, FALSE, UNKNOWN values.

**Table 11-35** Comparison conditions

| Condition | Description                                                                                                                                                                                     |
|-----------|-------------------------------------------------------------------------------------------------------------------------------------------------------------------------------------------------|
| =         | It checks if both conditions are equal.                                                                                                                                                         |
| !=, <>    | It checks if both conditions are not equal.                                                                                                                                                     |
| >         | It compares which one of both conditions is bigger.                                                                                                                                             |
| <         | It compares which one of both conditions is smaller.                                                                                                                                            |
| >=        | It compares which one of both conditions is bigger or equal.                                                                                                                                    |
| <=        | It compares which one of both conditions is smaller or equal.                                                                                                                                   |
| ANY, SOME | If there is a condition whose left expr satisfies at least one of right expr_list (or subquery results), then it returns TRUE.<br>If there is not right subquery result, then it returns FALSE. |
| ALL       | If there is a condition whose left expr satisfies all right expr_list (or subquery results), then it returns TRUE.<br>If there is not right subquery result, then it returns TRUE.              |

For more information, refer to **Type Comparison**.

## ◀ Simple Comparison Conditions ▶

### Syntax

```

<simple_comparison_condition> ::=
    <expr>          <comparison_operator> <expr>
  | <expr>          <comparison_operator> ( <subquery> )
  | ( <subquery> ) <comparison_operator> <expr>
  | ( <subquery> ) <comparison_operator> ( <subquery> )
  | ( <expr_list> ) <comparison_operator> ( <expr_list> )
  | ( <expr_list> ) <comparison_operator> ( <subquery> )
  | ( <subquery> ) <comparison_operator> ( <expr_list> )
  | ( <subquery> ) <comparison_operator> ( <subquery> )

<comparison_operator> ::=
    < = >
  | < != >
  | < < >
  | < > >
  | < <= >
  | < >= >

<expr_list> ::=
    <expr>
  | <expr>, ... , <expr>
  | ( <expr> )

```



```
| ( <expr> , ... , <expr> )
```

For more information, refer to [Scalar Subquery Expression](#).

## Description

If the expr list or subquery comes to both left and right of comparison\_operator, then the number of expr or subquery target to be compared should be same.

If there is a subquery, the number of result records should be one.

## Example

**Table 11-36** Example of simple comparison conditions

| Conditional expression     | Result |
|----------------------------|--------|
| 'abc' = 'abc'              | TRUE   |
| 'abc' != 'abc'             | FALSE  |
| 'abc' < 'abc'              | FALSE  |
| 'abc' <= 'abc'             | TRUE   |
| 'abc' > 'abc'              | FALSE  |
| 'abc' >= 'abc'             | TRUE   |
| ( 1, 2, 3 ) = ( 1, 2, 3 )  | TRUE   |
| ( 1, 2, 3 ) = ( 1, 2, 4 )  | FALSE  |
| ( 1, 2, 3 ) != ( 4, 5, 6 ) | TRUE   |
| ( 1, 2, 3 ) != ( 1, 2, 3 ) | FALSE  |
| ( 1, 2, 3 ) < ( 1, 2, 4 )  | TRUE   |
| ( 1, 2, 3 ) < ( 1, 2, 3 )  | FALSE  |
| ( 1, 2, 3 ) <= ( 1, 2, 4 ) | TRUE   |
| ( 1, 2, 3 ) <= ( 1, 2, 2 ) | FALSE  |
| ( 1, 2, 3 ) > ( 1, 2, 2 )  | TRUE   |
| ( 1, 2, 3 ) > ( 1, 2, 4 )  | FALSE  |
| ( 1, 2, 3 ) >= ( 1, 2, 2 ) | TRUE   |
| ( 1, 2, 3 ) >= ( 1, 2, 4 ) | FALSE  |

## <Group Comparison Conditions>

### Syntax

```
<group_comparison_condition> ::=
    <expr>          <comparison_operator> <quantifier> ( <expr_list> )
  | <expr>          <comparison_operator> <quantifier> ( <subquery> )
  | ( <expr_list> ) <comparison_operator> <quantifier> ( <expr_list_list> )
```

```

| ( <expr_list> ) <comparison_operator> <quantifier> ( <subquery> )
| ( <subquery> ) <comparison_operator> <quantifier> ( <expr_list> )
| ( <subquery> ) <comparison_operator> <quantifier> ( <expr_list_list> )
| ( <subquery> ) <comparison_operator> <quantifier> ( <subquery> )
<comparison_operator> ::=
    < = >
    | < != >
    | < < >
    | < > >
    | < <= >
    | < >= >
<quantifier> ::=
    ALL
    | ANY
    | SOME
<expr_list> ::=
    <expr>
    | <expr>, ... , <expr>
    | ( <expr> )
    | ( <expr> , ... , <expr> )
<expr_list_list> ::=
    <expr_list>
    | <expr_list>, ... , <expr_list>

```

For more information, refer to [Scalar Subquery Expression](#).

## Description

If the expr list or subquery comes to both left and right of comparison\_operator, then the number of expr or subquery target to be compared should be same.

If a subquery comes to the left of comparison\_operator, the number of result records should be one.

If a subquery comes to the right of comparison\_operator, the number of result records can be multiple.

## Example

**Table 11-37** Example of group comparison conditions

| Conditional expression      | Result |
|-----------------------------|--------|
| 1 =any ( 1, 2, 3, 4, 5 )    | TRUE   |
| 1 =any ( 1, 2, null, 4, 5 ) | TRUE   |
| 1 =any ( 2, null, 4, 5 )    | NULL   |
| 1 =any ( 100, 2, 3, 4, 5 )  | FALSE  |
| 1 =all ( 1, +1, 1E+0 )      | TRUE   |

| Conditional expression                                                     | Result |
|----------------------------------------------------------------------------|--------|
| 1 =all ( 1, +1, 1E+0, null )                                               | NULL   |
| 1 =all ( 1, 2, 3, 4, 5 )                                                   | FALSE  |
| ( 1, 2 ) =any ( ( 0, 1 ), ( 1, 2 ), ( 3, 4 ) )                             | TRUE   |
| ( 1, 2 ) =any ( ( 0, 1 ), ( 1, 2 ), ( null, null ) )                       | TRUE   |
| ( 1, 2 ) =any ( ( 0, 1 ), ( 2, 3 ), ( 3, 4 ) )                             | FALSE  |
| ( 1, 2 ) =all ( ( 1, 2 ), ( +1, +2 ), ( 1E+0, 2E+0 ) )                     | TRUE   |
| ( 1, 2 ) =all ( ( 1, 2 ), ( +1, +2 ), ( null, null ) )                     | NULL   |
| ( 1, 2 ) =all ( ( 0, 1 ), ( 2, 3 ), ( 3, 4 ) )                             | FALSE  |
| <b>When the result record of comparison_operator's right subquery is 0</b> |        |
| ('X') =any ( select dummy from dual where dummy = 'Y' )                    | FALSE  |
| ('X') =all ( select dummy from dual where dummy = 'Y' )                    | TRUE   |

## Logical Conditions

Logical conditions are such as AND, OR, NOT.

### AND

#### Syntax

| <boolean value expression> AND <boolean value expression>

#### Description

Table 11-38 Truth table of AND boolean operator

| AND     | True    | False | Unknown |
|---------|---------|-------|---------|
| True    | True    | False | Unknown |
| False   | False   | False | False   |
| Unknown | Unknown | False | Unknown |

### OR

#### Syntax

| <boolean value expression> OR <boolean value expression>

## Description

**Table 11-39** Truth table of OR boolean operator

| OR      | True | False   | Unknown |
|---------|------|---------|---------|
| True    | True | True    | True    |
| False   | True | False   | Unknown |
| Unknown | True | Unknown | Unknown |

## NOT

### Syntax

**|** NOT <boolean value expression>

### Description

**Table 11-40** Truth table of NOT boolean operator

| expr    | NOT     |
|---------|---------|
| True    | False   |
| False   | True    |
| Unknown | Unknown |

## Null Condition

### Syntax

**|** <expr> IS [NOT] NULL

### Description

It checks whether the result value of expr is NULL.

**Table 11-41** Result table of IS NULL condition

| expr     | IS NULL | IS NOT NULL |
|----------|---------|-------------|
| NULL     | True    | False       |
| NOT NULL | False   | True        |

## Compound Conditions

It is a conditional expression in which multiple conditions are combined.

```
compound_condition ::=
    ( condition )
    | NOT condition
    | condition < AND | OR > condition
```

## Pattern-matching Conditions

### Like Condition

#### Syntax

```
like_condition ::=
    string [NOT] LIKE pattern [ ESCAPE escape_character ]
```

#### Description

It checks if a string matches the specified pattern.

Arguments such as string, pattern, escape\_character can be of a character type such as CHARACTER, CHARACTER VARYING, CHARACTER LONG VARYING, or of the type which is available to be converted to a character type.

If string, pattern, escape\_character are NULL, it returns NULL.

If escape\_character is omitted, there is not a default value.

If escape\_character is specified, the escape\_character should be one character.

If pattern does not include '\_' nor '%', it is processed in the same way as equal operation(string = pattern)

.

If pattern includes '\_' or '%', the string checks if it matches as follows.

- '\_': If it corresponds to one arbitrary character.
- '%': If it corresponds to the arbitrary character string which has zero or more characters.

Use ESCAPE syntax to compare '\_' or '%' included in the pattern with characters.

Specify escape\_character, and describe the specified escape\_character before the pattern's '\_' or '%'.

## Example

```

gSQL> SELECT 'hello%' LIKE 'h%o!%' ESCAPE '!' AS RESULT FROM DUAL;
RESULT
-----
TRUE
• 'represent' LIKE 'represent' => TRUE
• 'represent' LIKE ' represent ' => FALSE
• 'represent' LIKE 'REPRESENT' => FALSE
• 'represent' LIKE 'r_pr_s_nt' => TRUE
• 'represent' LIKE 're%t' => TRUE
• 'represent' LIKE 'rep' => FALSE
• 'summer_vacation' LIKE 'summer\_vacation' ESCAPE '\' => TRUE
• NULL LIKE 'summer\_vacation' ESCAPE '\' => NULL
• 'summer_vacation' LIKE NULL ESCAPE '\' => NULL
• 'summer_vacation' LIKE 'summer\_vacation' ESCAPE NULL => NULL

```

## BETWEEN Condition

### Syntax

```

<between condition> ::=
  <expr1> [ NOT ] BETWEEN [ ASYMMETRIC | SYMMETRIC ] <expr2> AND <expr3>

```

### Description

It checks whether `expr1` is within the range between `expr2` and `expr3`.

If `ASYMMETRIC` or `SYMMETRIC` is omitted, the default is `ASYMMETRIC`.

If data types among `expr1`, `expr2`, `expr3` are different, they are converted.

For more information, refer to [Type Comparison](#), [Type Conversion](#).

**Table 11-42** Equivalence of between conditions

| A                               | B                                            |
|---------------------------------|----------------------------------------------|
| X BETWEEN ASYMMETRIC Y AND Z    | X BETWEEN Y AND Z                            |
| X BETWEEN Y AND Z               | X >= Y AND X <= Z                            |
| X NOT BETWEEN Y AND Z           | NOT( X BETWEEN Y AND Z )                     |
| X BETWEEN SYMMETRIC Y AND Z     | ((X BETWEEN Y AND Z) OR (X BETWEEN Z AND Y)) |
| X NOT BETWEEN SYMMETRIC Y AND Z | NOT( X BETWEEN SYMMETRIC Y AND Z )           |

## Example

Table 11-43 Example of between condition

|                        | Conditional expression         | Result |
|------------------------|--------------------------------|--------|
| BETWEEN [ ASYMMETRIC ] | 3 BETWEEN 1 AND 5              | TRUE   |
|                        | NULL BETWEEN 1 AND 5           | NULL   |
|                        | 3 BETWEEN NULL AND 5           |        |
|                        | 3 BETWEEN 1 AND NULL           |        |
|                        | 3 BETWEEN 5 AND 1              | FALSE  |
| BETWEEN SYMMETRIC      | 3 BETWEEN SYMMETRIC 1 AND 5    | TRUE   |
|                        | NULL BETWEEN SYMMETRIC 1 AND 5 | NULL   |
|                        | 3 BETWEEN SYMMETRIC NULL AND 5 |        |
|                        | 3 BETWEEN SYMMETRIC 1 AND NULL |        |
|                        | 3 BETWEEN SYMMETRIC 5 AND 1    | TRUE   |

## IN Condition

### Syntax

```

<in_condition> ::=
    <expr>          [NOT] IN ( <expr_list> )
  | <expr>          [NOT] IN ( <subquery> )
  | ( <expr_list> ) [NOT] IN ( <expr_list_list> )
  | ( <expr_list> ) [NOT] IN ( <subquery> )
  | ( <subquery> ) [NOT] IN ( <expr_list> )
  | ( <subquery> ) [NOT] IN ( <expr_list_list> )
  | ( <subquery> ) [NOT] IN ( <subquery> )

<expr_list> ::=
    <expr>
  | <expr>, ... , <expr>
  | ( <expr> )
  | ( <expr> , ... , <expr> )

<expr_list_list> ::=
    <expr_list>
  | <expr_list>, ... , <expr_list>

```

## Description

IN condition returns the same result as = ANY.

NOT IN condition returns the same result as !=ALL.

For more information, refer to **Comparison Conditions**.

## Example

**Table 11-44** Example of IN condition

| Conditional expression        | Result |
|-------------------------------|--------|
| 1 IN ( 1, 2, 3, 4, 5 )        | TRUE   |
| 1 IN ( 1, 2, null, 4, 5 )     | TRUE   |
| 1 IN ( 2, null, 4, 5 )        | NULL   |
| 1 IN ( 100, 2, 3, 4, 5 )      | FALSE  |
| NULL IN ( 1, 2, 3 )           | NULL   |
| 1 NOT IN ( 2, 3, 4, 5 )       | TRUE   |
| 1 NOT IN ( 2, null, 4, 5 )    | NULL   |
| 1 NOT IN ( 1, 2, null, 4, 5 ) | FALSE  |
| 1 NOT IN ( 100, 2, 3, 4, 5 )  | TRUE   |
| NULL NOT IN ( 1, 2, 3 )       | NULL   |

## EXISTS Condition

### Syntax

```
exists_conditions ::=
    EXISTS ( subquery )
```

### Description

It checks whether the result record of subquery exists.

If the result record of subquery exists, it returns TRUE. Otherwise, it returns FALSE.



## Example

```

gSQL> SELECT * FROM DUAL WHERE EXISTS ( SELECT * FROM DUAL );
      DUMMY
      -----
      X
1 row selected.
gSQL> SELECT * FROM DUAL
      WHERE EXISTS ( SELECT * FROM DUAL WHERE DUMMY = 'Y' );
no rows selected.

```

## Compatibility

The SQL standard compatibility for condition is as follows.

**Table 11-45** SQL standard compatibility for condition

| Feature ID | Description                                                  | Availability |
|------------|--------------------------------------------------------------|--------------|
| E061-01    | Comparison predicate                                         | O            |
| E061-02    | BETWEEN predicate                                            | O            |
| E061-03    | IN predicate with list of values                             | O            |
| E061-04    | LIKE predicate                                               | O            |
| E061-05    | LIKE predicate: ESCAPE clause                                | O            |
| E061-06    | NULL predicate                                               | O            |
| E061-07    | Quantified comparison predicate                              | O            |
| E061-08    | EXISTS predicate                                             | O            |
| E061-09    | Subqueries in comparison predicate                           | O            |
| E061-11    | Subqueries in IN predicate                                   | O            |
| E061-12    | Subqueries in quantified comparison predicate                | O            |
| E061-13    | Correlated subqueries                                        | O            |
| E061-14    | Search condition                                             | O            |
| F051-04    | Comparison predicate on DATE, TIME, and TIMESTAMP data types | X            |
| F053       | OVERLAPS predicate                                           | X            |
| F263       | Comma-separated predicates in simple CASE expression         | X            |
| F291       | UNIQUE predicate                                             | X            |
| F481       | Expanded NULL predicate                                      | O            |
| F841       | LIKE_REGEX predicate                                         | X            |
| P008       | Comma-separated predicates in a CASE statement Extended CASE | X            |
| S151       | Type predicate                                               | X            |
| T141       | SIMILAR predicate                                            | X            |

| Feature ID | Description                                          | Availability |
|------------|------------------------------------------------------|--------------|
| T151       | DISTINCT predicate                                   | X            |
| T152       | DISTINCT predicate with negation                     | X            |
| T461       | Symmetric BETWEEN predicate                          | O            |
| T501       | Enhanced EXISTS predicate                            | O            |
| T631       | IN predicate with one list element                   | X            |
| X090       | XML document predicate                               | X            |
| X091       | XML content predicate                                | X            |
| X141       | IS VALID predicate: data-driven case                 | X            |
| X142       | IS VALID predicate: ACCORDING TO clause              | X            |
| X143       | IS VALID predicate: ELEMENT clause                   | X            |
| X144       | IS VALID predicate: schema location                  | X            |
| X145       | IS VALID predicate outside check constraints         | X            |
| X151       | IS VALID predicate with DOCUMENT option              | X            |
| X152       | IS VALID predicate with CONTENT option               | X            |
| X153       | IS VALID predicate with SEQUENCE option              | X            |
| X155       | IS VALID predicate: NAMESPACE without ELEMENT clause | X            |
| X157       | IS VALID predicate: NO NAMESPACE with ELEMENT clause | X            |

# 12.

---

## SQL Languages

Structured Query Languages (SQL) are classified as follows.

- Data Definition Language
- Data Manipulation Language
- Data Query Language
- Control Language

# 12.1 Data Definition Language

## DDL Related Statements

For more information, refer to the followings.

- Non-schema object DDL
  - Database Related Statements
  - Profile Related Statements
  - Audit Policy Related Statement
  - Authorization Related Statements
  - Schema Related Statements
  - Tablespace Related Statements
- SQL schema object DDL
  - Table Related Statements
  - Index Related Statements
  - View Related Statements
  - Sequence Related Statements
  - Synonym Related Statements
- Cluster object DDL
  - Cluster System Related Statements
  - Cluster Group Related Statements
  - Cluster Member Related Statements
  - Cluster Location Related Statements
  - Global Secondary Index Related Statements

## Concepts of DDL

Data Definition Language (DDL) is an SQL language which creates, drops and alters SQL objects.

SQL objects of a database are listed in the following table. For more information, refer to the links in the following table.

**Table 12-1** SQL objects types

| Object type | Object | Description                                  | Refer to |
|-------------|--------|----------------------------------------------|----------|
|             |        | It is an object which defines a password man |          |

| Object type       | Object                 | Description                                                           | Refer to                       |
|-------------------|------------------------|-----------------------------------------------------------------------|--------------------------------|
| Non-schema object | Profile                | agement policy.                                                       | <b>Profile</b>                 |
|                   | Audit policy           | It is an object which defines the SQL audit policy.                   | <b>Audit Policy</b>            |
|                   | User                   | It is a user object which consists of a set of privileges.            | <b>Authorization</b>           |
|                   | Schema                 | It is a logical position including SQL schema objects such as tables. | <b>Schema</b>                  |
|                   | Tablespace             | It is a physical storage of objects such as tables, indexes, etc.     | <b>Tablespace</b>              |
|                   | Public synonym         | It is a public synonym.                                               | <b>Public Synonym</b>          |
| SQL schema object | Table                  | It is a physical relation where the data is stored.                   | <b>Table</b>                   |
|                   | View                   | It is a logical relation which consists of queries.                   | <b>View</b>                    |
|                   | Index                  | It is an index object to improve query performance.                   | <b>Index</b>                   |
|                   | Sequence               | It is an object which generate sequence number.                       | <b>Sequence</b>                |
|                   | Synonym                | It is an object which declares an alias for an object.                | <b>Synonym</b>                 |
|                   | Stored procedure       | It is a user defined procedure object.                                | <b>Stored Procedure</b>        |
|                   | Stored function        | It is a user defined function object.                                 | <b>Stored Function</b>         |
| Cluster object    | Cluster group          | It is a cluster member set.                                           | <b>Cluster Group</b>           |
|                   | Cluster member         | It is a data server which configures a cluster system.                | <b>Cluster Member</b>          |
|                   | Cluster location       | It is a location object of a cluster member.                          | <b>Cluster Location</b>        |
|                   | Shard                  | It is a set of rows which horizontally divides a cluster table.       | <b>Cluster Table and Shard</b> |
|                   | Global secondary index | It is an index for the row identifier of a cluster.                   | <b>Global Secondary Index</b>  |

## DDL and Transaction

A transaction of GOLDILOCKS includes not only DML statements such as INSERT, DELETE, UPDATE data, but also DDL statement such as CREATE, DROP, ALTER objects. Many DBMS performs implicit transactions of DDL. On the other hand, GOLDILOCKS includes a DDL statement in the transaction, and it guarantees the atomicity and consistency of transaction.

This feature is useful when a user needs to atomically perform batch DDL such as database migration or tool installation, or to recover a mistake through ROLLBACK when statement such as DROP TABLE or TRU

NCATE TABLE is executed by user mistake.

If the property of DDL statement is auto-commit, then it automatically commits when executing the statement. On the other hand, if it is not auto-commit, then it can rollback the transaction even after the statement was executed. Whether the DDL is auto-commit or not is queried by using **V\$SQL\_COMMAND** view as follows.

```
gSQL>
```

```
SELECT command, auto_commit
   FROM V$SQL_COMMAND
  WHERE is_ddl = 'YES';
```

| COMMAND                                         | AUTO_COMMIT |
|-------------------------------------------------|-------------|
| -----                                           | -----       |
| ALTER AUDIT POLICY                              | YES         |
| ALTER CLUSTER GROUP .. ADD CLUSTER MEMBER       | YES         |
| ALTER CLUSTER GROUP .. OFFLINE CLUSTER MEMBER   | YES         |
| ALTER DATABASE DROP INACTIVE CLUSTER MEMBERS    | YES         |
| ALTER DATABASE OFFLINE INACTIVE CLUSTER MEMBERS | YES         |
| ALTER DATABASE RESET LOCAL CLUSTER MEMBER       | YES         |
| ALTER DATABASE ADD LOGFILE GROUP                | YES         |
| ALTER DATABASE ADD LOGFILE MEMBER               | YES         |
| ALTER DATABASE DROP LOGFILE GROUP               | YES         |
| ALTER DATABASE DROP LOGFILE MEMBER              | YES         |
| ALTER DATABASE RENAME LOGFILE                   | YES         |
| ALTER DATABASE ARCHIVELOG                       | YES         |
| ALTER DATABASE NOARCHIVELOG                     | YES         |
| ALTER DATABASE DATAFILE AUTOEXTEND ..           | YES         |
| ALTER DATABASE CLEAR PASSWORD HISTORY           | NO          |
| ALTER FUNCTION                                  | NO          |
| ALTER INDEX AGING                               | NO          |
| ALTER INDEX .. STORAGE                          | NO          |
| ALTER INDEX .. RENAME                           | NO          |
| ALTER INDEX .. REBUILD                          | YES         |
| ALTER PACKAGE                                   | YES         |
| ALTER PROCEDURE                                 | NO          |
| ALTER PROFILE                                   | YES         |
| ALTER SEQUENCE                                  | YES         |
| ALTER SEQUENCE .. SYNCHRONIZE                   | YES         |
| ALTER SYSTEM SWITCH LOGFILE                     | YES         |
| ALTER TABLE .. ADD COLUMN                       | NO          |
| ALTER TABLE .. SET UNUSED COLUMN                | NO          |
| ALTER TABLE .. ALTER COLUMN .. SET DEFAULT      | NO          |

|                                                           |     |
|-----------------------------------------------------------|-----|
| ALTER TABLE .. ALTER COLUMN .. DROP DEFAULT               | NO  |
| ALTER TABLE .. ALTER COLUMN .. SET NOT NULL               | NO  |
| ALTER TABLE .. ALTER COLUMN .. DROP NOT NULL              | NO  |
| ALTER TABLE .. ALTER COLUMN .. SET DATA TYPE              | YES |
| ALTER TABLE .. ALTER COLUMN .. AS IDENTITY                | YES |
| ALTER TABLE .. ALTER COLUMN .. DROP IDENTITY              | YES |
| ALTER TABLE .. RENAME COLUMN                              | NO  |
| ALTER TABLE .. STORAGE                                    | NO  |
| ALTER TABLE .. ADD CONSTRAINT                             | NO  |
| ALTER TABLE .. ALTER CONSTRAINT                           | NO  |
| ALTER TABLE .. DROP CONSTRAINT                            | NO  |
| ALTER TABLE .. RENAME CONSTRAINT                          | NO  |
| ALTER TABLE .. RENAME TO ..                               | NO  |
| ALTER TABLE .. REBALANCE ..                               | YES |
| ALTER TABLE .. MOVE SHARD .. TO CLUSTER GROUP ..          | YES |
| ALTER TABLE .. SPLIT SHARD .. INTO .. AT CLUSTER GROUP .. | YES |
| ALTER TABLE .. MERGE SHARDS .. INTO ..                    | YES |
| ALTER TABLE .. RENAME SHARD .. TO ..                      | NO  |
| ALTER TABLE .. ADD SUPPLEMENTAL LOG                       | NO  |
| ALTER TABLE .. ADD GLOBAL SECONDARY INDEX                 | NO  |
| ALTER TABLE .. ALTER GLOBAL SECONDARY INDEX               | NO  |
| ALTER TABLE .. ALTER GLOBAL SECONDARY INDEX AGING         | NO  |
| ALTER TABLE .. DROP GLOBAL SECONDARY INDEX                | NO  |
| ALTER TABLE .. REBUILD GLOBAL SECONDARY INDEX             | YES |
| ALTER TABLE .. DROP SUPPLEMENTAL LOG                      | NO  |
| ALTER TABLE .. READ ONLY                                  | YES |
| ALTER TABLE .. READ WRITE                                 | YES |
| ALTER TABLE .. SYNCHRONIZE IDENTITY COLUMN                | YES |
| ALTER TABLESPACE .. ADD                                   | YES |
| ALTER TABLESPACE .. DROP                                  | YES |
| ALTER TABLESPACE .. ONLINE                                | YES |
| ALTER TABLESPACE .. OFFLINE                               | YES |
| ALTER TABLESPACE .. RENAME TO                             | YES |
| ALTER TABLESPACE .. RENAME { DATAFILE   MEMORY }          | YES |
| ALTER USER                                                | YES |
| ALTER USER .. IDENTIFIED BY                               | YES |
| ALTER VIEW                                                | NO  |
| ANALYZE SYSTEM COMPUTE STATISTICS                         | NO  |
| ANALYZE SYSTEM DELETE STATISTICS                          | NO  |
| ANALYZE TABLE .. [COMPUTE ESTIMATE] STATISTICS            | YES |
| ANALYZE TABLE .. DELETE STATISTICS                        | NO  |

|                            |     |
|----------------------------|-----|
| AUDIT POLICY               | YES |
| COMMENT ON .. IS           | NO  |
| CREATE AUDIT POLICY        | YES |
| CREATE CLUSTER GROUP       | YES |
| CREATE FUNCTION            | NO  |
| CREATE INDEX               | NO  |
| CREATE PACKAGE             | YES |
| CREATE PACKAGE BODY        | YES |
| CREATE PROCEDURE           | NO  |
| CREATE PROFILE             | YES |
| CREATE SCHEMA              | YES |
| CREATE SEQUENCE            | YES |
| CREATE SYNONYM             | NO  |
| CREATE TABLE               | NO  |
| CREATE TABLE ... AS SELECT | NO  |
| CREATE TABLESPACE          | YES |
| CREATE USER                | YES |
| CREATE VIEW                | NO  |
| DROP AUDIT POLICY          | YES |
| DROP CLUSTER GROUP         | YES |
| DROP FUNCTION              | NO  |
| DROP INDEX                 | NO  |
| DROP PACKAGE               | YES |
| DROP PROCEDURE             | NO  |
| DROP PROFILE               | YES |
| DROP SCHEMA                | YES |
| DROP SEQUENCE              | YES |
| DROP SYNONYM               | NO  |
| DROP TABLE                 | NO  |
| DROP TABLESPACE            | YES |
| DROP USER                  | YES |
| DROP VIEW                  | NO  |
| GRANT .. ON DATABASE       | NO  |
| GRANT .. ON TABLESPACE     | NO  |
| GRANT .. ON SCHEMA         | NO  |
| GRANT .. ON TABLE          | NO  |
| GRANT USAGE ON ..          | NO  |
| GRANT .. ON PROCEDURE      | NO  |
| GRANT .. ON PACKAGE        | NO  |
| NOAUDIT POLICY             | YES |
| REVOKE .. ON DATABASE      | NO  |



```

REVOKE .. ON TABLESPACE          NO
REVOKE .. ON SCHEMA                NO
REVOKE .. ON TABLE                NO
REVOKE USAGE ON ..                NO
REVOKE .. ON PROCEDURE             NO
REVOKE .. ON PACKAGE               NO
TRUNCATE TABLE                    NO
PURGE CONSTRAINT                   NO
PURGE INDEX                         NO
PURGE TABLE                       NO
PURGE TABLESPACE                  YES
PURGE RECYCLEBIN                   YES
PURGE DBA_RECYCLEBIN               YES
FLASHBACK TABLE                   YES
125 rows selected.

```

The followings are examples of COMMIT and ROLLBACK when table-related DDL statements are included in the transactions, and examples of its effects on other transactions. The example shows that the transaction including DDL guarantees the transaction atomicity. In addition, it ensures the reading consistency of the transaction, which is not affected by other transactions before transaction's commitment or when the transaction is rolled back.

## Creating Object and Transaction

- Before committing or rolling back a transaction of creating table

When a table is created, and transaction is not committed, the table data can be manipulated on the DDL transaction as follows. However, other transactions are not allowed to enquire the table until the creating table transaction is committed. CREATE TABLE statement, like as INSERT statement, can not be queried by any other transaction until the transaction is committed.

- Transaction A: Table t1 is created but the transaction is not committed.

```

gSQL> CREATE TABLE t1 ( id INTEGER, name VARCHAR(128) );
Table created.
gSQL> INSERT INTO t1 VALUES ( 1, 'leekmo' );
1 row created.
gSQL> SELECT * FROM t1;
ID NAME
-- -----
1 leekmo

```

1 row selected.

As above, if table t1 is created on the transaction A and the transaction is not yet committed, the transaction B in another session can not enquire the table t1 and can not create the table named as t1.

- Transaction B: Table t1 can not be enquired until committing the transaction A.

```
gSQL> SELECT * FROM t1;
ERR-42000(16040): table or view does not exist :
SELECT * FROM t1
          *
ERROR at line 1:
```

- Table t1 can not be created until the transaction A is rolled back.

```
gSQL> CREATE TABLE t1 ( emp_no INTEGER );
ERR-HYT00(14026): resource busy or timeout expired
```

- After committing a transaction of creating table

If the transaction A is committed, table t1 can be enquired by the transaction B and CREATE TABLE statement returns a validation error to notify that the table t1 exists as follows.

- Transaction B: After committing the transaction A, the table can be enquired as follows.

```
gSQL> SELECT * FROM t1;
ID NAME
-- -----
1 leekmo
1 row selected.
```

- After the transaction A is committed, a validation error is returned.

```
gSQL> CREATE TABLE t1 ( emp_no INTEGER );
ERR-42000(16005): name 'PUBLIC.T1' is already used by an existing object :
CREATE TABLE t1 ( emp_no INTEGER )
          *
ERROR at line 1:
```

- After rolling back a transaction of creating table

If the transaction A is rolled back, creating table t1 is also rolled back, and table t1 can be created by the transaction B.

- Transaction B: The transaction A is rolled back and its state becomes as same as before creating table t1.

```
gSQL> SELECT * FROM t1;
ERR-42000(16040): table or view does not exist :
SELECT * FROM t1
          *
ERROR at line 1:
```

- The transaction A is rolled back and it can create the table t1.

```
gSQL> CREATE TABLE t1 ( emp_no INTEGER );
Table created.
```

## Dropping Object and Transaction

- Before committing or rolling back a transaction of dropping table

When a table is dropped, and transaction is not committed, other transactions can enquire the dropped table until the DROP TABLE transaction is committed. DROP TABLE statement, like as DELETE statement, retrieves the state of before deleting the table when other transaction enquires it until the transaction is committed.

The following example describes the state which the transaction A drops the table t1, then it creates new table t1, and the transaction is not committed.

- Transaction A: There is a row having two columns in the table t1 before dropping the table.

```
gSQL> SELECT * FROM t1;
ID NAME
-- -----
1 leekmo
1 row selected.
```

- Dropping the existing table t1

```
gSQL> DROP TABLE t1;
Table dropped.
```

- Creating the new table t1

```
gSQL> CREATE TABLE t1 ( addr VARCHAR(128) );
Table created.
```

- Creating a new row in the newly created table t1

```
gSQL> INSERT INTO t1 VALUES ( 'Seoul, Korea' );
1 row created.
gSQL> SELECT * FROM t1;
ADDR
-----
Seoul, Korea
1 row selected.
```

If the transaction B enquires when the transaction A is not committed, the information which is before the transaction A is executed is obtained as follows. DROP TABLE statement, like as DELETE statement, does not affect any other transaction until the transaction is committed.

- Transaction B: The transaction B retrieves the table which is before the execution of the transaction A.

```
gSQL> SELECT * FROM t1;
ID NAME
-- -----
1 leekmo
1 row selected.
```

- After committing a transaction of dropping table

If the transaction A is committed, then the transaction B enquires the newly created table t1 as follows.

- Transaction B: After committing the transaction A, the transaction B enquires the newly created table t1.

```
gSQL> SELECT * FROM t1;
ADDR
-----
Seoul, Korea
1 row selected.
```

- After rolling back a transaction of dropping table

If the transaction A is rolled back, the transaction B enquires the table t1 which is before the execution of the transaction A as follows. Namely, if the transaction A is rolled back, the rollback transaction does not

affect the data of which the transaction B enquires.

- Transaction B: If the transaction A is rolled back, the transaction B enquires the information which is before the execution of the transaction A.

```
gSQL> SELECT * FROM t1;
ID NAME
-- -----
1 leekmo
1 row selected.
```

## Altering Object and Transaction

ALTER TABLE statement is used to alter the table structure. ALTER TABLE statement also ensures atomicity and consistency of the transaction like as CREATING TABLE or DROPPING TABLE statements. Before committing a transaction in which a column is added to a table, other transactions retrieve the information of the existing table as follows. Namely, ALTER TABLE statement, like as UPDATE statement, retrieves information which is before DDL transaction in other transaction until the transaction is committed.

- Transaction A: It adds a new UPDATE\_TIME column.

```
gSQL> ALTER TABLE t1 ADD COLUMN ( update_time TIMESTAMP DEFAULT CURRENT_TIMESTAMP );
Table altered.
```

- The table t1 including the added column is retrieved.

```
gSQL> select * from t1;
ID NAME    UPDATE_TIME
-- -----
1 leekmo 2014-07-10 12:50:33.540495
1 row selected.
```

If the transaction B is executed before committing the transaction A as follows, then the table t1 which is before adding a column is retrieved.

- Transaction B: The added column UPDATE\_TIME is not retrieve, because the transaction A is not committed.

```
gSQL> SELECT * FROM t1;
ID NAME
-- -----
1 leekmo
1 row selected.
```

## 12.2 Data Manipulation Language

### DML Related Statements

For more information, refer to the followings.

- INSERT related statements
  - **INSERT INTO**
  - **INSERT INTO name RETURNING**
  - **INSERT INTO name RETURNING .. INTO**
- UPDATE related statements
  - **UPDATE**
  - **UPDATE name RETURNING**
  - **UPDATE name RETURNING .. INTO**
  - **UPDATE name WHERE CURRENT OF cursor\_name**
- DELETE related statements
  - **DELETE FROM**
  - **DELETE FROM name RETURNING**
  - **DELETE FROM name RETURNING .. INTO**
  - **DELETE FROM name WHERE CURRENT OF cursor\_name**
- SELECT related statements: **SELECT .. INTO**
- Dynamic SQL related statements
  - **EXECUTE IMMEDIATE 'sql\_string'**
  - **PREPARE statement\_name**
  - **EXECUTE statement\_name**

### Concepts of DML

Data Manipulation Language (DML) is an SQL language which manipulates and enquires data in existing tables such as INSERT, DELETE, UPDATE.

This chapter describes only DML statements which change data. For more information about queries, refer to **Data Query Language**.

The DDL statements change the SQL object structure, but DML statements manipulate the objects contents. For example, ALTER TABLE statement alters the table structure, but INSERT statement adds one or more rows in the table.

DML statements such as inserting, deleting, updating data in table are classified as follows.

**Table 12-2** Data manipulation statements

| Category | Statements                 | Description                                           |
|----------|----------------------------|-------------------------------------------------------|
| INSERT   | INSERT .. VALUES           | It adds a single row to the table.                    |
|          | INSERT .. SELECT           | It adds the query results to the table.               |
|          | INSERT .. RETURN .. INTO   | It sets the value of the added row as a variable.     |
|          | INSERT .. RETURN           | It retrieves the added row as the query result.       |
| DELETE   | DELETE .. WHERE            | It deletes the row which satisfies the condition.     |
|          | DELETE .. WHERE CURRENT OF | It deletes the row which is at the cursor's position. |
|          | DELETE .. RETURN .. INTO   | It sets the value of the removed row as a variable.   |
|          | DELETE .. RETURN           | It retrieves the removed row as the query result.     |
| UPDATE   | UPDATE .. WHERE            | It updates the row which satisfies the condition.     |
|          | UPDATE .. WHERE CURRENT OF | It updates the row which is at the cursor's position. |
|          | UPDATE .. RETURN .. INTO   | It sets the value of the updated row as a variable.   |
|          | UPDATE .. RETURN           | It retrieves the updated row as the query result.     |

## Inserting Data

It adds data in a row unit when adding data to a table. The INSERT statement can add one or more rows to a table. Even when the data in some columns are omitted, all rows are added with completed columns to the table.

The following is an example of a table.

```
CREATE TABLE t1
(
  id    NUMBER(10,0),
  name  VARCHAR(128),
  addr  VARCHAR(1024) DEFAULT 'n/a'
);
```

The most basic way to add a row is as follows.

```
INSERT INTO t1 VALUES ( 1, 'leekmo', 'Seoul, Korea' );
```

The values listed in the VALUES clause are inserted in accordance with the sequence of the listed column when the table is created.

However, the example above can cause an unexpected failure when inserting or deleting columns, so it is recommended to explicitly specify the column name as follows.

```
INSERT INTO t1 (id, name, addr) VALUES ( 1, 'leekmo', 'Seoul, Korea' );
INSERT INTO t1 (name, addr, id) VALUES ( 'leekmo', 'Seoul, Korea', 1 );
```

The two INSERT statements above are listed in different order from the columns, but the added row of the table t1 has the same data.

If the table does not list all the columns, unspecified column is set to the default value to complete the row. The addr column which was not used in the statement stores the default value (n/a) which was specified when creating table as follows.

```
INSERT INTO t1 ( id, name ) VALUES ( 1, 'leekmo' );
INSERT INTO t1 ( id, name ) SELECT id, name FROM emp;
```

Use DEFAULT to explicitly specify the default value for the column as follows.

```
INSERT INTO t1 ( id, name, addr ) VALUES ( 1, 'leekmo', DEFAULT );
```

Use either of the following two statements to set all the columns to the default value.

```
INSERT INTO t1 ( id, name, addr ) VALUES ( DEFAULT, DEFAULT, DEFAULT );
INSERT INTO t1 DEFAULT VALUES;
```

Use a single INSERT statement to add multiple rows. The following is an example of adding three new rows using a single INSERT statement.

```
INSERT INTO t1 (id, name, addr) VALUES
  ( 1, 'leekmo', 'Seoul, Korea' ),
  ( 2, 'mkkim', 'Seoul, Korea' ),
  ( 3, 'xcom', 'Inchon, Korea' );
```

Use the SELECT query results to add multiple rows. The following is an example of adding rows to the table t1 by retrieving employees who joined the company more than three years ago.

```
INSERT INTO t1 ( id, name, addr )
SELECT id, name, addr
FROM emp
WHERE DATEDIFF( YEAR, SYSDATE, join_date ) >= 3;
```



## Deleting Data

DELETE statement deletes data from the table in a row unit like when inserting data. Rows can be deleted by using WHERE condition or by using row's ID(ROWID).

The following is an example of deleting rows which satisfy WHERE condition.

```
DELETE FROM t1 WHERE id = 1;
```

The following is an example of deleting the row using ROWID.

```
gSQL> SELECT rowid FROM t1 WHERE id = 1;
                ROWID
-----
AAAAAAAAFNHAACAAAAiAAA
1 row selected.
gSQL> DELETE FROM t1 WHERE ROWID = 'AAAAAAAAFNHAACAAAAiAAA';
1 row deleted.
```

DELETE statement without a WHERE clause deletes the entire row in a table. DELETE statement without a WHERE clause is similar to TRUNCATE TABLE statement in terms of deleting entire row, but it is recommended to use the TRUNCATE TABLE statement.

```
DELETE FROM t1;
TRUNCATE TABLE t1;
```

## Updating Data

Update data by using UPDATE statement. One or more rows and columns can be updated. Other columns which is not specified in the UPDATE statement is not affected.

The following is an example of updating a column in rows which satisfy the condition.

```
UPDATE t1 SET page_view = page_view + 1 WHERE id = 1;
```

The followings are examples of updating multiple columns, and the two UPDATE statements mean the same.

```
UPDATE t1 SET page_view = page_view + 1, status = 'F' WHERE id = 1;
UPDATE t1 SET (page_view, status) = (page_view + 1, 'F') WHERE id = 1;
```

Use DEFAULT as follows to set the column value to a default value.

```
UPDATE t1 SET addr = DEFAULT WHERE id = 1;
```

## Manipulating Data Using Cursor

Cursor is a session object to execute queries and to manipulate the query result. Use cursor to update or delete the query result set.

The following is an example of declaring updatable cursor, and updating or deleting the row at the position of the current cursor using the updatable cursor.

```
gSQL> DECLARE cur1 CURSOR FOR SELECT id, data FROM t1 FOR UPDATE;
Cursor declared.
gSQL> OPEN cur1;
Cursor is open.
gSQL> \var v_id INTEGER
gSQL> \var v_data VARCHAR(128)
gSQL> FETCH cur1 INTO :v_id, :v_data;
V_ID V_DATA
----
      1 data_1
1 row fetched.
gSQL> FETCH cur1 INTO :v_id, :v_data;
V_ID V_DATA
----
      2 data_2
1 row fetched.
gSQL> DELETE FROM t1 WHERE CURRENT OF cur1;
1 row deleted.
gSQL> FETCH cur1 INTO :v_id, :v_data;
V_ID V_DATA
----
      3 data_3
1 row fetched.
gSQL> UPDATE t1 SET id = id + :v_id WHERE CURRENT OF cur1;
1 row updated.
gSQL> COMMIT;
Commit complete.
gSQL> SELECT * FROM t1 ORDER BY 1;
```

```
ID DATA
-- -----
1 data_1
6 data_3
2 rows selected.
```

The examples above describe the followings.

Use **DECLARE cursor\_name** to declare FOR UPDATE cursor, and use **OPEN cursor\_name** to open the cursor.

Use **FETCH cursor\_name** to move the cursor to the specified position.

Use **DELETE FROM name WHERE CURRENT OF cursor\_name** to delete the row in the specified position.

Use **UPDATE name WHERE CURRENT OF cursor\_name** to update the row in the specified position.

FOR UPDATE cursor is closed using **CLOSE cursor\_name**, or it is closed when committing transaction.

## DML Query

When executing DML statements changing the data, use RETURNING clause to retrieve the changed data. The RETURNING clause of DML statements, like as SELECT, can retrieve data, so the execution of the DML statement and the SELECT statement can be replaced with the DML query.

The following is an example of using **INSERT INTO name RETURNING** syntax to insert data and retrieve the result. The join\_date value which was input by using SYSDATE function can be retrieved by a single DML query.

```
gSQL> INSERT INTO t1 ( id, join_date ) VALUES ( 1, SYSDATE ) RETURNING id, join_date;
ID JOIN_DATE
-- -----
1 2014-07-18
1 row created.
```

The following is an example of using **DELETE FROM name RETURNING** syntax to delete data and retrieve the result. The result data can be manipulated by using operation in RETURNING clause.

```
gSQL> DELETE FROM t1 RETURNING ( id || ': ' || join_date ) AS id_and_join_date;
ID_AND_JOIN_DATE
-----
1: 2014-07-18
1 row deleted.
```

The following is an example of using **UPDATE name RETURNING** syntax to update rows and retrieve the

updated values. The value which is before updating can be retrieved by using OLD clause.

- It updates the row and retrieves the updated value.

```
gSQL> UPDATE t1 SET page_view = page_view + 1 WHERE id = 1 RETURNING page_view;
PAGE_VIEW
-----
      102
1 row updated.
```

- It updates the row and retrieves the value which is before the updating.

```
gSQL> UPDATE t1 SET page_view = page_view + 1 WHERE id = 1 RETURNING OLD page_view;
PAGE_VIEW
-----
      102
1 row updated.
```

RETURNING clause of DML statements, like as SELECT query, can retrieve multiple query results. However, if the DML is executed only for a single row, then the host variable can be obtained by using RETURNING INTO clause. In this case, the number of changed rows should be one or less, like SELECT .. INTO clause .

The following is an example of setting the value to the host variable using RETURNING .. INTO clause of each DML statement.

- It declares the host variable.

```
gSQL> \var v_id          INTEGER
gSQL> \var v_page_view  BIGINT
gSQL> \var v_date       DATE
```

- After inserting the row, a value is set to the host variable.

```
gSQL> INSERT INTO t1 ( id, join_date ) VALUES ( 1, SYSDATE ) RETURNING join_date INTO :v_date;
V_DATE
-----
2014-07-18 16:57:11.000000
1 row created.
```

- After updating the row, a value is set to the host variable.

```
gSQL> UPDATE t1 SET page_view = page_view + 1 WHERE id = 1 RETURN page_view INTO :v_page_view;
V_PAGE_VIEW
```

```
-----  
          101  
1 row updated.
```

- After deleting the row, a value is set to the host variable.

```
gSQL> DELETE FROM t1 WHERE id = 1 RETURN id, page_view INTO :v_id, :v_page_view;  
V_ID V_PAGE_VIEW  
----  
    1          101  
1 row deleted.
```

For more information about DML query, refer to the followings.

- **INSERT INTO name RETURNING**
- **INSERT INTO name RETURNING .. INTO**
- **DELETE FROM name RETURNING**
- **DELETE FROM name RETURNING .. INTO**
- **UPDATE name RETURNING**
- **UPDATE name RETURNING .. INTO**

## 12.3 Data Query Language

### Query Related Statements

For more information, refer to the followings.

- SELECT query related statements
  - SELECT
  - SELECT .. FOR UPDATE
- DML query related statements
  - INSERT INTO name RETURNING
  - UPDATE name RETURNING
  - DELETE FROM name RETURNING
- Cursor related statements
  - DECLARE cursor\_name
  - OPEN cursor\_name
  - FETCH cursor\_name
  - CLOSE cursor\_name
  - DELETE FROM name WHERE CURRENT OF cursor\_name
  - UPDATE name WHERE CURRENT OF cursor\_name

### Concepts of Query

Query means a series of operations to retrieve data for one or more of the table or view. By using the query, a user can get the result data which satisfies the specific condition in the desired form from the stored data.

Query is a SELECT statement which is at the top in the entire SQL statement separated by ';'. Top-level SELECT statement can include another SELECT statement in it. In this case, the subordinate SELECT statement is called as a subquery.

In GOLDILOCKS, query is divided into SELECT query, DML query, and cursor. SELECT query returns the result by using the SELECT statement. DML query returns the result by using the RETURNING phrase in INSERT, DELETE, UPDATE statements. Cursor temporarily saves the result sets when it is enquired once, and randomly accesses to a row of the saved result set, then brings the result.

A user can get the results at once by using SELECT query and DML query. On the other hand, by using th

e cursor, SELECT statement specified with DECLARE cursor is executed in OPEN cursor, and then it holds the result set until CLOSE cursor is called. Then it repeatedly brings the result by randomly accessing a row of the result set using FETCH cursor.

This chapter describes SELECT query, DML query and cursor.

## Basic Query

The basic form of a query is *SELECT <select list> FROM <table expression>*. *<select list>* which is between SELECT and FROM keywords, specifies one or more columns or expressions to be included in rows which are the result for the table or view described in *<table expression>*.

```
SELECT n_name
       , INITCAP( n_name )
FROM nation
WHERE n_regionkey = 1;
```

| N_NAME        | INITCAP( N_NAME ) |
|---------------|-------------------|
| ARGENTINA     | Argentina         |
| BRAZIL        | Brazil            |
| CANADA        | Canada            |
| PERU          | Peru              |
| UNITED STATES | United States     |

5 rows selected.

One or more tables or views can be described in *<table expression>*, and same column can be included in two tables or views. In this case, the name of table or view should be specified together when describing that column in *<select list>*. When describing a table or a column, it is recommended to clearly describe the schema names and table names, etc.

- A wrong example

```
SELECT n_name
FROM nation AS n
     , v_nation AS v
WHERE n.n_nationkey = v.n_nationkey
     AND v.n_regionkey = 1;
```

ERR-42000(16142): column ambiguously defined :

```
SELECT n_name
       *
```

ERROR at line 1:

- A correct example

```
SELECT n.n_name
      FROM nation AS n
           , v_nation AS v
 WHERE n.n_nationkey = v.n_nationkey
       AND v.n_regionkey = 1;
N_NAME
-----
ARGENTINA
BRAZIL
CANADA
PERU
UNITED STATES
5 rows selected.
```

<select list> supports the alias name. It changes output column names in each columns which are separated by comma (,). Alias name can be used only in the <order by clause>, and it can not to be used in other phrases.

```
SELECT p_type
      , p_retailprice * 0.9 AS discount_price
 FROM part
 ORDER BY discount_price
 FETCH 5;
  2    3    4    5
P_TYPE          DISCOUNT_PRICE
-----
PROMO BURNISHED COPPER          810.9
ECONOMY BRUSHED NICKEL          810.9
LARGE BRUSHED BRASS             811.8
LARGE BRUSHED NICKEL            811.8
PROMO ANODIZED STEEL            811.8
5 rows selected.
```

In addition to <select list>, <hint clause> and <set quantifier> can also be used between SELECT and FROM keywords. <hint clause> allows a user to directly adjust the query execution plan. For more information, refer to **SQL Hint**. <set quantifier> removes the duplicate data of the row which is returned as the result. For more information, refer to **query specification**.



- An example of using hint

```
SELECT
    /*+ INDEX( part ) */
    p_type
    , p_retailprice
FROM part
WHERE p_partkey = 100;
P_TYPE          P_RETAILPRICE
-----
ECONOMY ANODIZED TIN      1000.1
1 row selected.
```

- An example of using <set quantifier>

```
SELECT DISTINCT
    o_orderpriority
FROM orders;
O_ORDERPRIORITY
-----
5-LOW
2-HIGH
3-MEDIUM
1-URGENT
4-NOT SPECIFIED
5 rows selected.
```

## SET Operator

SET operators combine the result set of two or more queries into a single result set. SET operators are UNION, EXCEPT, INTERSECT, and MINUS. MINUS operates as same as EXCEPT. Each SET operator has additional options such as ALL and DISTINCT. If the option is omitted, DISTINCT is used by default.

When using the SET operators to describe two or more queries, generally the queries are processed sequentially from the left. When parentheses are used to explicitly specify the processing order of the queries, then those queries are processed first.

```
SELECT n_name
FROM nation
WHERE n_nationkey < 10
```

```

INTERSECT
( SELECT n_name
  FROM nation
  WHERE n_regionkey = 1
UNION ALL
SELECT n_name
  FROM nation
  WHERE n_regionkey = 2 );
N_NAME
-----
BRAZIL
ARGENTINA
INDONESIA
INDIA
CANADA
5 rows selected.

```

Each query of the SET operators should have the same number of the target, and the target at the same positions of each query should have a data type which belongs to the same group.

⟨order by clause⟩ of SET operator sorts the final result set. Each query of SET operators can have its own ⟨order by clause⟩ to sort themselves.

For more information about SET operators, refer to **set operator**.

## Common Table Expression (CTE)

The temporary result set configured through ⟨with clause⟩ is called as Common Table Expression (CTE). CTE defined in the syntax can be referenced within the execution range. One or more CTE are configured in ⟨with clause⟩, and each CTE can be configured by referencing CTE including itself. Repeatedly executing the query to configure the temporary result set is called as recursive subquery factoring.

CTE is classified into recursive CTE and non-recursive CTE.

Referring to CTE which is currently defined within CTE (self-reference CTE) is called as recursive CTE. CTE other than recursive CTE is called as non-recursive CTE.

```

* recursive CTE
WITH RECURSIVE_CTE ( c1 ) AS
(
  SELECT 1
  FROM dual

```

```

        UNION ALL
        SELECT c1 + 1
           FROM RECURSIVE_CTE
           WHERE c1 < 10
    )
SELECT c1 FROM RECURSIVE_CTE;

```

① Self reference

```

* non-recursive CTE
WITH NON_RECURSIVE_CTE ( c1 ) AS
(
    SELECT i1
       FROM t1
    UNION ALL
    SELECT i1
       FROM t2
)
SELECT c1 FROM NON_RECURSIVE_CTE;

```

## Recursive CTE

Recursive CTE always consists of two query block sets using UNION ALL. The query block including self-reference CTE is called as a recursive member query, and other query blocks are called as anchor member queries.

```

WITH CTE_RECURSIVE( c1, c2 ) AS
(
    SELECT i1, i2
       FROM t1
       WHERE i2 IS NULL
    UNION ALL
    SELECT i1, i2
       FROM CTE_RECURSIVE, t1
       WHERE CTE_RECURSIVE.c1 = t1.i2
)
SELECT c1, c2 FROM CTE_RECURSIVE;

```

① Anchor member query

② Recursive member query

Recursive CTE configures records acquired from an anchor member query into the temporary result set, and acquires those records through CTE reference in the recursive member query. Recursive CTE also configures results acquired from the recursive member query into the temporary result set, and tries to execute the recursive member query again. This process is repeated until it is unable to configure the temporary result set.

<search clause> is used to specify the sequence of the record configuration configured in the current step. <search clause> supports DEPTH FIRST BY and BREADTH FIRST BY. <search clause> can be described only within recursive CTE.

For more information, refer to <search clause>.

```

gSQL> SELECT * FROM t1;
I1  I2
--- ---
A   ---
AA  A
AB  A
AC  A
AAX AA
ABX AB
ACX AC
7 rows selected.
* SEARCH BREADTH FIRST BY
gSQL> WITH w1( w_i1, w_i2 ) AS
  (
    SELECT i1, i2
      FROM t1
     WHERE i1 = 'A'
    UNION ALL
    SELECT i1, i2
      FROM w1, t1
     WHERE w_i1 = i2
  ) SEARCH BREADTH FIRST BY w_i1, w_i2 SET w_seq
SELECT w_i1, w_i2, w_seq
FROM w1;
W_I1 W_I2 W_SEQ
---- ---- -----
A    ---    1
AA   A     2
AB   A     3
AC   A     4
AAX  AA    5
ABX  AB    6
ACX  AC    7
7 rows selected.
* SEARCH DEPTH FIRST BY
gSQL> WITH w1( w_i1, w_i2 ) AS

```

```

(
  SELECT i1, i2
    FROM t1
   WHERE i1 = 'A'
 UNION ALL
  SELECT i1, i2
    FROM w1, t1
   WHERE w_i1 = i2
) SEARCH DEPTH FIRST BY w_i1, w_i2 SET w_seq
SELECT w_i1, w_i2, w_seq
  FROM w1;
W_I1 W_I2 W_SEQ
---- ----
A    ---    1
AA   A      2
AAX  AA     3
AB   A      4
ABX  AB     5
AC   A      6
ACX  AC     7
7 rows selected.

```

When configuring the results configured in the previous step into the current temporary result set, then recursive CTE is infinitely executed. In this case, the system determines that the cycle occurs, so it causes cycle detected error.

The comparing target is selected through <cycle clause> to determine whether cycle occurs, and whether cycle occurred is also can be seen. If using <cycle clause>, it does not cause an error for cycle detected when cycle occurred.

When <cycle clause> is not specified, then all columns used when defining CTE are selected as targets of determining whether cycle occurred.

```

gSQL> SELECT * FROM t1;
I1  I2
--- --
A   ---
AA  A
AB  A
AC  A
AA  AA
AAX AA

```

```
ABX AB
```

```
ACX AC
```

```
8 rows selected.
```

- When cycle occurred but cycle clause is not described

```
gSQL> WITH w1( w_i1, w_i2 ) AS
  (
    SELECT i1, i2
      FROM t1
     WHERE i1 = 'A'
    UNION ALL
    SELECT i1, i2
      FROM w1, t1
     WHERE w_i1 = i2
  )
SELECT w_i1, w_i2
  FROM w1;
ERR-42000(16511): cycle detected while executing recursive WITH query
```

- When cycle occurred and cycle clause is described

```
gSQL> WITH w1( w_i1, w_i2 ) AS
  (
    SELECT i1, i2
      FROM t1
     WHERE i1 = 'A'
    UNION ALL
    SELECT i1, i2
      FROM w1, t1
     WHERE w_i1 = i2
  ) CYCLE w_i1, w_i2 SET c_cycle TO 'T' DEFAULT 'F'
SELECT w_i1, w_i2, c_cycle
  FROM w1;
W_I1 W_I2 C_CYCLE
---- ----
A    --- F
AC   A    F
AB   A    F
AA   A    F
ACX  AC   F
ABX  AB   F
AAX  AA   F
```

```
AA  AA  F
AAX AA  F
AA  AA  T
10 rows selected.
```

## Join

Join is a query that combines rows from more than one table or view in `<from clause>`. If there is not a join condition, the result is obtained by combining each result row of the left table or view with each result row of the right table or view.

If tables or views have a column name in common when joining two or more tables or views in `<from clause>`, a user should distinguish these columns by using the table or view name in `<select list>`, `<where clause>`. Otherwise, a validation error occurs.

Join queries either contain the join condition or do not contain the join condition. Join condition is for comparing columns from two different tables or views. If the join condition is not specified, each row of a table or view is combined with each row of another table or view, and the combined row is returned. If the join condition is specified, rows from each table or view which satisfies the join condition, are returned in the combined form.

Equi-join is a join whose join condition contains an equality operator(=). Equi-join condition is an important factor in optimizing the join operation by the optimizer.

Self-join is a join operation which has only the same tables in `<from clause>`. To describe column in `<select list>`, the alias name in each table is described and table alias in column is used.

## CROSS JOIN

CROSS JOIN is a join operation whose join condition does not exist, and it is also called as Cartesian Product. CROSS JOIN combines each row of one table or view with each row of the other, and the combined row is returned as a result.

```
SELECT a.r_name
       , b.r_name
FROM region AS a
       , region AS b
FETCH 5;
```

| R_NAME | R_NAME  |
|--------|---------|
| AFRICA | AFRICA  |
| AFRICA | AMERICA |

```

AFRICA          ASIA
AFRICA          EUROPE
AFRICA          MIDDLE EAST
5 rows selected.

```

## INNER JOIN

INNER JOIN returns the rows which satisfy the join condition for two or more tables or views. INNER JOIN is when *inner join* is explicitly specified in <from clause>. Or, when tables or views are listed with comma (,) in <from clause> and its join condition is specified in <where clause>.

If there are explicit *inner join* in <from clause>, and the join condition in <where clause>, then they are processed as one inner join condition.

- An example of using an INNER JOIN statement

```

SELECT n_name
   FROM region INNER JOIN nation ON r_regionkey = n_regionkey
  WHERE r_name = 'AFRICA';
N_NAME
-----
ALGERIA
ETHIOPIA
KENYA
MOROCCO
MOZAMBIQUE
5 rows selected.

```

- An example of a list using a comma (,)

```

SELECT n_name
   FROM region
      , nation
  WHERE r_regionkey = n_regionkey
      AND r_name = 'AFRICA';
N_NAME
-----
ALGERIA
ETHIOPIA
KENYA
MOROCCO
MOZAMBIQUE

```



5 rows selected.

## OUTER JOIN

OUTER JOIN returns all rows which satisfy the join condition for two or more tables or views. It also returns rows which do not satisfy the join condition for one or both side of table or view depending on the direction of OUTER JOIN.

OUTER JOIN can be classified as LEFT OUTER JOIN , RIGHT OUTER JOIN, FULL OUTER JOIN. All three OUTER JOIN return rows which satisfy the join condition, but they are distinguished by the additional results. LEFT OUTER JOIN returns all rows of the left table which do not satisfy the join condition by filling NULL for all of its right rows. RIGHT OUTER JOIN returns all rows of the right table which do not satisfy the join condition by filling NULL for all of its left rows. FULL OUTER JOIN returns all additional return results of LEFT OUTER JOIN and RIGHT OUTER JOIN.

```
SELECT r_name
       , n_name
FROM region LEFT OUTER JOIN nation
      ON r_regionkey = n_regionkey AND r_name = 'AFRICA';
```

| R_NAME      | N_NAME     |
|-------------|------------|
| AFRICA      | ALGERIA    |
| AFRICA      | ETHIOPIA   |
| AFRICA      | KENYA      |
| AFRICA      | MOROCCO    |
| AFRICA      | MOZAMBIQUE |
| AMERICA     | null       |
| ASIA        | null       |
| EUROPE      | null       |
| MIDDLE EAST | null       |

9 rows selected.

GOLDILOCKS supports the outer join operator(+) for compatibility with Oracle, and which is not supported in the SQL standard. The outer join operator(+) lists tables by using a comma(,) in <from clause> and it adds a (+) to a node column which is operated as the outer node in the join condition of <where clause>.

When using the outer join operator (+), the sign(+) should be specified on the right side of the column as follows.

```
select * from t1, t2 where t1.i1 = t2.i1(+);
```

The syntax rules of the outer join operator (+) are as follows.

- <Join outer operator> can be used only for <where clause>.
- <Join outer operator> can be used only for <column reference> of <table reference> which is a target of <joined table>.
- <value expression> including <join outer operator>, can not be combined with other conditions which use <OR logical operator>.
- <column reference> including <join outer operator> can not be used as the argument of IN function.
- A <table reference> can not be used as null generated table of many outer joins (constraints on the outer join)
- When executing the outer join of two or more tables, they are listed according to the left outer join sequence, and executes the outer join from the very left of them.
- When executing outer join between two or more tables and multiple tables are combined into a table by the outer join, then the outer join is executed according to the sequence of calculation by an optimizer.

Even when the outer join operator (+) is specified, it is ignored in the following cases.

- <join outer operator> can be used for <value expression> which can be used as the join condition between the two tables, if it can not be used as the join condition, then it is ignored and an error or warning does not occur.
- <join outer operator> which is specified in <column reference> of the outer query is ignored, and an error or warning does not occur.
- If two <table reference> are outer joined using <join outer operator>, then <join outer operator> should be specified in all <column reference> which belong to null generated tables. Otherwise, join of two <table reference> is processed as an inner join, an error or warning does not occur.

Differences between Oracle and GOLDILOCKS for the outer join operator (+) are as follows.

- Quantified comparison (in, = any, = all = row, etc.)
  - GOLDILOCKS: It processes the operation as a validation error.
  - Oracle: The and/or operation is applied, and performs the validation check.
- Or sub-clause in an *and* clause
  - GOLDILOCKS: Validation is applied on the columns of an *or* sub-clause.
  - Oracle: Validation is ignored on the columns of an *or* sub-clause.
- When the condition clause includes a subquery
  - GOLDILOCKS: The outer join is applied and the condition is processed as a join condition.
  - Oracle: The outer join is applied but the condition is processed as a where filter.



GOLDILOCKS supports the outer join operator (+) for compatibility with Oracle. It is recommended to specify OUTER JOIN in <from clause>. (Oracle also recommends to specify OUTER JOIN in <from clause>.)

## NATURAL JOIN

NATURAL JOIN uses the join condition of an equality operator(=) for columns of same name when joining two or more tables or views. It is as same as INNER JOIN except that NATURLAL JOIN has the implicit join condition for columns of the same name.

```
SELECT r_name
   FROM region a NATURAL JOIN region b;
```

| R_NAME      |
|-------------|
| AFRICA      |
| AMERICA     |
| ASIA        |
| EUROPE      |
| MIDDLE EAST |

5 rows selected.

## SEMI JOIN

SEMI JOIN returns the corresponding left rows if there exist right rows which satisfy the join condition. Unlike other join operations to return the rows which combine the left and right rows, SEMI JOIN returns only the left rows as the result.

- An example of using the semi join

```
SELECT r_name
   FROM region
  WHERE r_regionkey IN ( SELECT n_regionkey
                        FROM nation
                        WHERE n_nationkey < 5 );
```

| R_NAME      |
|-------------|
| AFRICA      |
| AMERICA     |
| MIDDLE EAST |

3 rows selected.

## ANTI-SEMI JOIN

ANTI-SEMI JOIN returns the corresponding left rows if there does not exist any right rows which satisfy the join condition. It returns only the left rows as the result like as SEMI JOIN.

- An example of using the anti-semi join

```
SELECT r_name
   FROM region
  WHERE r_regionkey NOT IN ( SELECT n_regionkey
                           FROM nation
                           WHERE n_nationkey < 5 );
```

R\_NAME

-----

ASIA

EUROPE

2 rows selected.

For more information about the join operation, refer to [joined table](#).

## Hierarchical Query

A hierarchical query can process the hierarchical model data. The hierarchical model data consists of the hierarchical relationship with the connecting condition.

Recursive CTE is used to express the hierarchical query. For more information, refer to [Recursive CTE](#).

The other way to configure a hierarchical query is using `<hierarchical query clause>`.

`<hierarchical query clause>` creates a hierarchy by using the given starting condition (`<start with clause>`) and child connecting condition (`<connect by clause>`), and configures the result record with depth-first method. `<hierarchical query clause>` should include `<connect by clause>`.

```
SELECT *
   FROM r_region
  WHERE r_population > 10000000
  START WITH r_name = 'EARTH'           ① Starting condition
 CONNECT BY r_domain = PRIOR r_name    ② Connecting condition
```

All expressions used as an argument of PRIOR operator among expressions described in `<connect by>` are configured into the result for the current hierarchy. Only the expressions configured into the result are used as targets to check whether cycle occurs. The results configured in this way can be referenced through `<hierarchy expression>`.

Whether cycle occurs in a hierarchical query is checked by repeatedly searching along the parent hierarchy based on currently configured result and checking whether the same result exists. When it is determined that cycle occurred based on the current result, then the information is set that the parent record of the

current result record includes the record where cycle occurred.

If searching for the record including cycle occurrence information, then the system determines that the cycle occurs, so it causes cycle detected error. If describing NOCYCLE in <connect by> statement, then it does not cause cycle detected error, and whether cycle occurs is known through CONNECT\_BY\_ISCYCLE which is one of <hierarchical expression>.

```
gSQL>
SELECT * FROM t1;
I1 I2
-- ----
A null
AA A
AB A
AC A
AA AA
AB AA
6 rows selected.

gSQL>
SELECT i1, i2, CONNECT_BY_ISCYCLE
FROM t1
START WITH i1 = 'A'
CONNECT BY NOCYCLE i2 = prior i1;
I1 I2 CONNECT_BY_ISCYCLE
-- ---- -----
A null 0
AA A 1
AB AA 0
AB A 0
AC A 0
5 rows selected.
```

Sibling records of the same parent records are sorted through <order sibling by clause>. <order sibling by clause> is applied when configuring the result record per each hierarchy.

However, <order by clause> which has a similar form sorts all records acquired from the query block. Therefore, <order sibling by clause> and <order by clause> do not affect each other, and constraints do not exist between them.

```
gSQL>
SELECT * FROM t1;
I1 I2
-- ----
```

```

A null
AA A
AB A
fAA AA
eAA AA
bAA AA
dAB AB
cAB AB
aAB AB
9 rows selected.

```

- The following is an example of defining the order of fetching sibling records of the same parent records.

```

gSQL>
SELECT LEVEL, i1, i2
  FROM t1
START WITH i1 = 'A'
CONNECT BY i2 = PRIOR i1
ORDER SIBLINGS BY i1;
LEVEL I1 I2
-----
1 A null
2 AA A
3 bAA AA
3 eAA AA
3 fAA AA
2 AB A
3 aAB AB
3 cAB AB
3 dAB AB
9 rows selected.

```

- The following is an example of sorting all results retrieved in a hierarchy by using ORDER BY clause in an order of LEVEL.

```

gSQL>
SELECT LEVEL, i1, i2
  FROM t1
START WITH i1 = 'A'
CONNECT BY i2 = PRIOR i1
ORDER SIBLINGS BY i1

```

```
ORDER BY LEVEL;
LEVEL I1 I2
-----
1 A null
2 AA A
2 AB A
3 bAA AA
3 eAA AA
3 fAA AA
3 aAB AB
3 cAB AB
3 dAB AB
9 rows selected.
```

## Order of Evaluating Hierarchical Query

⟨hierarchical query clause⟩ consists of ⟨start with connect by clause⟩ and ⟨order siblings by clause⟩.

Statements in ⟨hierarchical query clause⟩ are executed in the following order.

Results acquired through ⟨start with connect by clause⟩ from each hierarchy are sorted through ⟨order siblings by clause⟩. ⟨start with clause⟩ is evaluated for the root hierarchy and ⟨order siblings by clause⟩ is applied. Then, the result is configured by using ⟨connect by clause⟩ and ⟨order siblings by clause⟩ for child hierarchy which is configured later.

```
SELECT *
FROM r_region
START WITH r_name = 'EARTH'
CONNECT BY r_domain = PRIOR r_name
ORDER SIBLINGS BY r_name
```

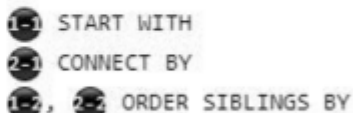

1-1 START WITH  
2-1 CONNECT BY  
1-2, 2-2 ORDER SIBLINGS BY

⟨hierarchical query clause⟩ in the query block is executed in the following order.

⟨hierarchical query clause⟩ is described between ⟨where clause⟩ and ⟨group by clause⟩ after ⟨from clause⟩. Unlike the describing order for ⟨hierarchical query clause⟩, ⟨hierarchical query clause⟩ is evaluated after ⟨from clause⟩ and before ⟨where clause⟩.

Conditions described in ⟨where clause⟩ do not affect the evaluation of ⟨hierarchical query clause⟩.

The followings are the evaluating order of ⟨hierarchical query clause⟩ according to the configuration of

<from clause> and <where clause>.

- When only a single table exists in *from* clause

```
SELECT *
  FROM r_region
 WHERE r_population > 10000000          ③ Condition in WHERE clause
 START WITH r_name = 'EARTH'           ① START WITH
 CONNECT BY r_domain = PRIOR r_name    ② CONNECT BY
```

- When join condition configured with multiple tables exists in *from* clause
  - When join condition is described in ON clause of FROM clause

```
SELECT *
  FROM r_region INNER JOIN s_region
        ON r_id = s_id                 ① Join condition in ON clause
 WHERE r_population > 10000000         ④ Condition in WHERE clause
 START WITH r_name = 'EARTH'           ② START WITH
 CONNECT BY r_domain = PRIOR r_name    ③ CONNECT BY
```

- When join condition is described in WHERE clause

```
SELECT *
  FROM r_region, s_region
 WHERE r_population > 10000000         ③ Condition in WHERE clause
        AND r_id = s_id                ③ Join condition in WHERE clause
 START WITH r_name = 'EARTH'           ① START WITH
 CONNECT BY r_domain = PRIOR r_name    ② CONNECT BY
```

- When join condition is described in both ON clause of FROM and in WHERE clause

```
SELECT *
  FROM r_region INNER JOIN s_region
        ON r_name = s_name              ① Join condition in ON clause
 WHERE r_population > 10000000         ④ Condition in WHERE clause
        AND r_id = s_id                ④ Join condition in WHERE clause
 START WITH r_name = 'EARTH'           ② START WITH
 CONNECT BY r_domain = PRIOR r_name    ③ CONNECT BY
```

If <group by clause> is used in a query block including <hierarchical query clause>, then it is able to configure the result set group by using <hierarchical expression>.



```

SELECT COUNT(*)
  FROM r_region
 START WITH r_name = 'EARTH'
CONNECT BY r_domain = PRIOR r_name
 GROUP BY PROIR r_domain

```

## Grouping Result Set (group by)

<group by clause> is used in order to group the rows which have the same column into one. <group by clause> lists and delimiters columns by using the comma (,), and GOLDILOCKS supports the group operation based on it.

```

SELECT
  o_orderpriority
  , MIN( o_totalprice ) AS min_price
  , MAX( o_totalprice ) AS max_price
 FROM orders
 GROUP BY
  o_orderpriority;
O_ORDERPRIORITY MIN_PRICE MAX_PRICE
-----
5-LOW            857.71 530604.44
2-HIGH           896.8 522720.61
3-MEDIUM        875.52 508668.52
1-URGENT         866.9 544089.09
4-NOT SPECIFIED 884.82 555285.16
5 rows selected.

```

If <group by clause> is specified, only the columns and the aggregate functions described in <group by clause> can be included in <select list>.

If only constants or parentheses instead of columns are specified in <group by clause>, it is assumed to be empty grouping set which includes the imaginary columns of the same value in each row. Then, the grouping in column base is performed. It is same when specifying <having clause> without <group by clause>.

<having clause> can be used to get the specified rows from grouped results by <group by clause>. <having clause> describes the conditions for each group, and it can describes the condition using the aggregate operation.

```

SELECT
    o_orderpriority
    , MIN( o_totalprice ) AS min_price
    , MAX( o_totalprice ) AS max_price
FROM orders
GROUP BY
    o_orderpriority
HAVING
    MIN( o_totalprice ) < 870;
O_ORDERPRIORITY MIN_PRICE MAX_PRICE
-----
5-LOW                857.71 530604.44
1-URGENT              866.9 544089.09
2 rows selected.

```

For more information about the grouping, refer to **group by clause**.

## Sorting Result Set (order by)

<Order by clause> sorts the result set based on the specific columns. <order by clause> can sort based on all types of column except the LONG type.

When a positive integer value is in <order by clause>, it means the column which is located in the corresponding to an integer value for the targets in the <select list>. The range of positive integer value which can be described in <order by clause> is from 1 and to the number of the targets in <select list>.

```

SELECT
    o_orderpriority
    , MIN( o_totalprice ) AS min_price
    , MAX( o_totalprice ) AS max_price
FROM orders
GROUP BY
    o_orderpriority
ORDER BY 1;
O_ORDERPRIORITY MIN_PRICE MAX_PRICE
-----
1-URGENT                866.9 544089.09
2-HIGH                  896.8 522720.61
3-MEDIUM                875.52 508668.52
4-NOT SPECIFIED         884.82 555285.16

```

```
5-LOW          857.71 530604.44
5 rows selected.
```

If the column data type in <order by clause> is numeric, it is sorted by numeric comparison. If the column data type is a character type, it is sorted by character comparison.

Each column in <order by clause> can be described by using the sorting direction option such as ASC, DESC. If it is omitted, it is regarded as ASC.

For more information about sorting, refer to **order by clause**.

## Subquery

Subquery supports a multi-level search request. The multi-level search request means that the result of the current query depends on the result of the subquery.

For example, the query to get people who are older than the average age of the people in a specific group is written in multi-step. The first query is to obtain the average age of people in a specific group, then the second query is to retrieve the number of people who are older than the average using the first query.

```
SELECT e_name
   FROM emp
  WHERE e_age > ( SELECT AVG(e_age)
                  FROM emp
                  WHERE e_dept = 'RND' );
```

A subquery can be used in <from clause>, <where clause>. The subquery in <from clause> is "inline view" and the subquery in <where clause> is "nested subquery".

The column name of a table or view in nested subquery can be same as the column name of a table or view in the query including the nested subquery when using the nested subquery. If only the column name exists in <select list> of the nested subquery, then it refers to the column of the table or view in the nested subquery. If the column name in <select list> of the nested subquery does not exist in the nested subquery's table or view, then it refers to the column name of the table or view in the query which includes the nested subquery, if exists.

```
SELECT r_name
   FROM region
  WHERE EXISTS ( SELECT *
                  FROM nation
                  WHERE n_nationkey < 5          /* nation.n_nationkey */
                  AND n_regionkey = r_regionkey ) /* nation.n_regionkey = region.r_regionkey
```

```
*/  
;
```

The optimizer unnests the nested subquery of <where clause> in the query which includes the nested subquery. Then it processes it as SEMI JOIN or ANTI-SEMI JOIN operation.

This is an optimization of the nested subquery, and the optimizer determines it by calculating the cost of unnesting if the subquery exists in IN, NOT IN, EXISTS, NOT EXISTS, quantify operator.

If a user wants to forcibly unnest the nested subquery, the user can use <hint clause> of nested subquery.

For more information about unnesting the nested subquery, refer to [SQL Hint](#).

```
SELECT r_name  
FROM region  
WHERE r_regionkey IN ( SELECT /*+ UNNEST */  
                        n_regionkey  
                        FROM nation  
                        WHERE n_nationkey < 5 );
```

For more information about subquery, refer to [subquery](#).

## 12.4 Control Language

### Control Language Related Statements

For more information, refer to the followings.

- Transaction control related statements
  - COMMIT
  - ROLLBACK
  - LOCK TABLE
  - SAVEPOINT *savepoint\_specifier*
  - RELEASE SAVEPOINT *savepoint\_specifier*
  
- Session control related statements: Refer to the followings.
  - ALTER SESSION SET *property\_name*
  - SET SESSION AUTHORIZATION *user\_identifier*
  - SET SESSION CHARACTERISTICS AS *transaction\_mode*
  - SET TIME ZONE
  - SET TRANSACTION *transaction\_mode*
  
- System control related statements: Refer to the followings.
  - ALTER SYSTEM CHECKPOINT
  - ALTER SYSTEM {MOUNT | OPEN} DATABASE
  - ALTER SYSTEM [KILL | DISCONNECT] SESSION
  - ALTER SYSTEM SET *property\_name*
  - ALTER SYSTEM RESET *property\_name*
  - ALTER SYSTEM SWITCH LOGFILE

### Transaction Control

Transaction control statements are used to manage the changes caused by executing DML or DDL statements in the transactions. Transaction control statements can be committed to keep the changes permanently, or rolled back to undo the changes.

Transaction control statements are classified as follows.

**Table 12-3** Transaction control statements

| Statement         | Description                                                              | Refer to                               |
|-------------------|--------------------------------------------------------------------------|----------------------------------------|
| COMMIT            | It terminates the transaction normally.                                  | COMMIT                                 |
| ROLLBACK          | It undoes the transaction.                                               | ROLLBACK                               |
| SAVEPOINT         | It creates the savepoint.                                                | 20.15 SAVEPOINT savepoint_specifier    |
| RELEASE SAVEPOINT | It removes the savepoint.                                                | RELEASE SAVEPOINT savepoint_specifier  |
| LOCK TABLE        | It sets the table-level lock.                                            | LOCK TABLE                             |
| SET TRANSACTION   | It controls the transaction properties.<br>(Read/write, isolation level) | 20.25 SET TRANSACTION transaction_mode |
| SET CONSTRAINTS   | It controls the checkpoint of the deferrable constraints.                | SET CONSTRAINTS                        |

A transaction is automatically created when the DML statements or DDL statements are executed for the first time. DML statements change the data and DDL statements change the SQL objects. However, the SELECT statements or the control statement do not generate a transaction.

The transaction rollbacks are classified as total rollback and partial rollback. The partial rollback is executed either in an explicit method or an implicit method. The total rollback is executed by ROLLBACK statement, and it undoes any changes performed by DML, DDL within the transaction.

The explicit partial rollback is a method which a user executes ROLLBACK statement using the savepoints as follows.

The following example describes that savepoints sp1, sp2 are declared, and then the partial rollback is explicitly executed.

```

gSQL> CREATE TABLE t1 ( id INTEGER, name VARCHAR(128) );
Table created.
gSQL> COMMIT;
Commit complete.
gSQL> INSERT INTO t1 VALUES ( 1, 'leekmo' );
1 row created.
gSQL> SAVEPOINT sp1;
Savepoint created.
gSQL> INSERT INTO t1 VALUES ( 2, 'mkkim' );
1 row created.
gSQL> SAVEPOINT sp2;
Savepoint created.
gSQL> INSERT INTO t1 VALUES ( 3, 'xcom' );
1 row created.
gSQL> ROLLBACK TO SAVEPOINT sp2;
Rollback complete.

```

```

gSQL> SELECT * FROM t1;
ID NAME
-- -----
 1 leekmo
 2 mkkim
2 rows selected.
gSQL> ROLLBACK TO SAVEPOINT sp1;
Rollback complete.
gSQL> SELECT * FROM t1;
ID NAME
-- -----
 1 leekmo
1 row selected.
gSQL> ROLLBACK WORK;
Rollback complete.
gSQL> SELECT * FROM t1;
no rows selected.

```

The implicit partial rollback is undoing only the changes of the corresponding statement when an error occurs while executing the statement.

The following example describes the implicit partial rollback.

If a unique constraint is violated, only the INSERT statement is rolled back and the previous changes of the transaction are retained.

```

gSQL> ALTER TABLE t1 ADD CONSTRAINT t1_uk UNIQUE(id);
Table altered.
gSQL> COMMIT;
Commit complete.
gSQL> INSERT INTO t1 VALUES ( 4, 'egonspace' );
1 row created.
gSQL> INSERT INTO t1 VALUES ( 1, 'jhkim' );
ERR-40002(16057): unique constraint (PUBLIC.T1_UK) violated
gSQL> SELECT * FROM t1;
ID NAME
-- -----
 1 leekmo
 2 mkkim
 3 xcom
 4 egonspace
4 rows selected.

```

## Session Control

Session is a logical object to manage the user's state information who accesses the database. Session control statement changes the session properties.

Session control statements are classified as follows.

**Table 12-4** Session control statements

| Statement                       | Description                                            | Refer to                                                          |
|---------------------------------|--------------------------------------------------------|-------------------------------------------------------------------|
| SET TRANSACTION CHARACTERISTICS | It controls the transaction properties in the session. | 20.23 SET SESSION CHARACTERISTICS AS TRANSACTION transaction_mode |
| SET TIME_ZONE                   | It alters the time zone of the session.                | SET TIME_ZONE                                                     |
| SET SESSION AUTHORIZATION       | It alters the user of the session.                     | SET SESSION AUTHORIZATION user_identifier                         |
| SET SCHEMA                      | It alters the session schema.                          | SET SCHEMA schema_name                                            |
| ALTER SESSION SET               | It alters the session property.                        | ALTER SESSION SET property_name                                   |

SET TRANSACTION statement is the transaction controlling statement and SET SESSION CHARACTERISTICS statement is session controlling statement. Both SET TRANSACTION statement and SET SESSION CHARACTERISTICS statement control the transaction properties.

The difference between SET TRANSACTION statement and SET SESSION CHARACTERISTICS statement is that SET TRANSACTION statement is applied only to a transaction which will be executed next. On the other hand, SET SESSION CHARACTERISTICS statement is applied for all transactions which occur in the session afterwards.

The following is a result of CURRENT\_TIMESTAMP statement which obtains the current date and time after changing the time zone by using SET TIME\_ZONE statement.

```
gSQL> SELECT CURRENT_TIMESTAMP FROM DUAL;
CURRENT_TIMESTAMP
-----
2014-07-21 11:42:49.828276 +09:00
1 row selected.
gSQL> SET TIME_ZONE '+00:00';
Session set.
gSQL> SELECT CURRENT_TIMESTAMP FROM DUAL;
CURRENT_TIMESTAMP
-----
2014-07-21 02:43:03.437940 +00:00
1 row selected.
```



## System Control

System control statements manage the database system, and they are classified as follows.

**Table 12-5** System control statements

| Statement                          | Description                                  | Refer to                                 |
|------------------------------------|----------------------------------------------|------------------------------------------|
| ALTER SYSTEM {OPEN MOUNT} DATABASE | It starts up the database.                   | ALTER SYSTEM {MOUNT   OPEN} DATABASE     |
| ALTER SYSTEM CHECKPOINT            | It performs the checkpoint.                  | ALTER SYSTEM CHECKPOINT                  |
| ALTER SYSTEM KILL SESSION          | It forcibly terminates the specific session. | ALTER SYSTEM [KILL   DISCONNECT] SESSION |
| ALTER SYSTEM SWITCH LOGFILE        | It switches the log file.                    | ALTER SYSTEM SWITCH LOGFILE              |
| ALTER SYSTEM SET                   | It sets the system properties.               | ALTER SYSTEM SET property_name           |
| ALTER SYSTEM RESET                 | It removes the system properties.            | ALTER SYSTEM RESET property_name         |

The following is an example of enquiring sessions connected to the database, and terminating the specific session.

```

gSQL> SELECT USER_NAME, SESSION_ID, SERIAL_NO, SESSION_STATUS, PROGRAM_NAME FROM V$SESSION
WHERE USER_NAME = 'TEST';
USER_NAME SESSION_ID SERIAL_NO SESSION_STATUS PROGRAM_NAME
-----
TEST          62          49 CONNECTED    gsql
TEST          65          109 CONNECTED    gsqlnet
TEST          66          130 CONNECTED    gsql
3 rows selected.
gSQL> ALTER SYSTEM DISCONNECT SESSION 65, 109;
System altered.

```

# 12.5 Processing SQL in Cluster

This chapter describes how to process various SQL statements in a cluster environment.

## Processing DDL in Cluster

### DDL Processing Procedure in Cluster

GOLDILOCKS cluster does not have a separate meta server, and a user can perform DDL in any cluster member configuring the cluster system.

DDL is executed following the procedure below in a cluster environment.

Figure 1 Processing DDL in cluster

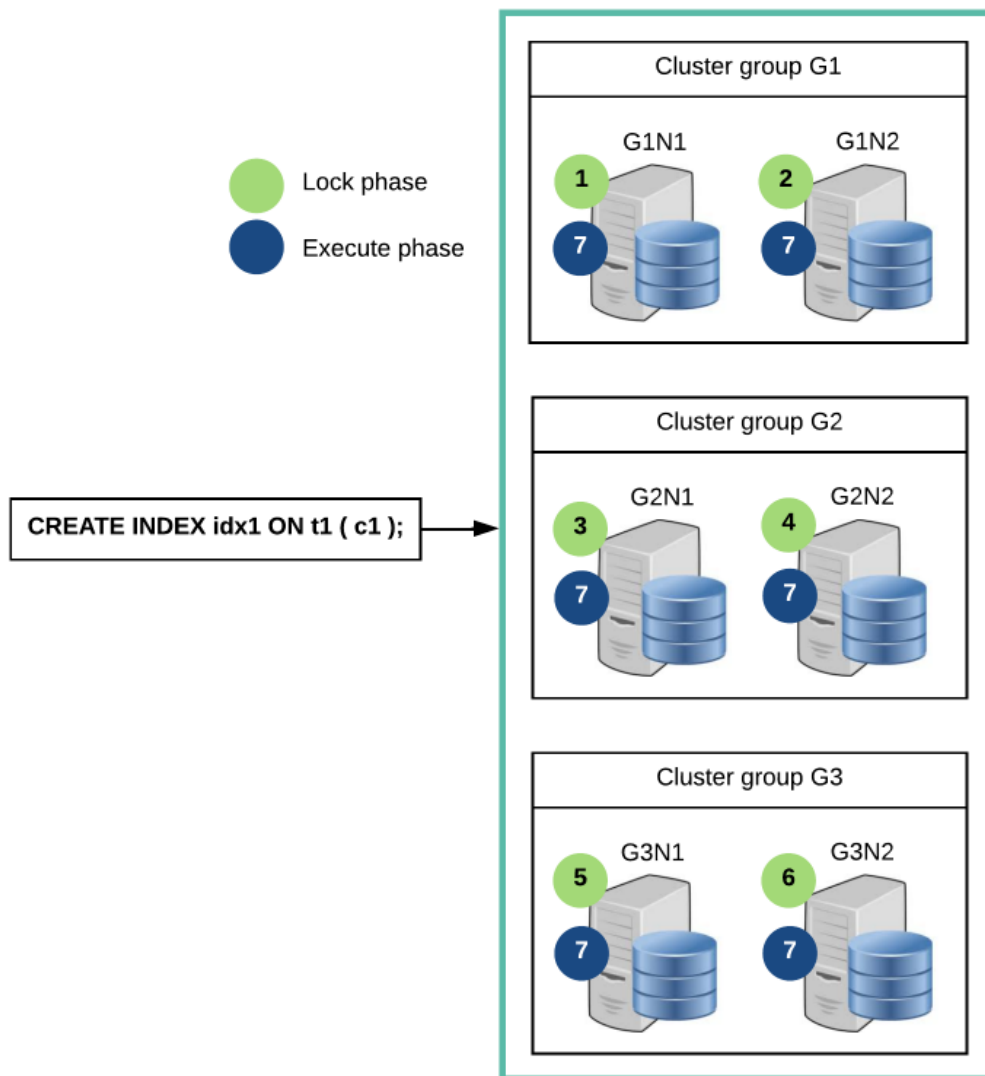

DDL is performed through two phases, which are a lock phase and an execution phase. On the lock phase, a lock which is required for performing DDL is acquired and DDL is sequentially performed on every cluster member. On the execute phase, DDL is simultaneously performed for every cluster member.

DDL is completed when DDL is successfully performed on every cluster member. If DDL fails on a specific cluster member, then DDL operations on every cluster member are cancelled. DDL can not be performed if an error occurred in any cluster member. All cluster members synchronize meta information for objects through this process.

## Simultaneous DDL Execution

The cluster object DDL which changes the cluster system configuration and the SQL object DDL can not be simultaneously performed. The availability of simultaneously performing the cluster object DDL and the SQL object DDL are as follows.

**Table 12-6** Availability of simultaneously performing DDL

| DDL                | Cluster object DDL | SQL object DDL |
|--------------------|--------------------|----------------|
| Cluster object DDL | X                  | X              |
| SQL object DDL     | X                  | O              |

The following DDL can not be simultaneously performed as given above.

- Cluster object DDL and cluster object DDL
  - (X) CREATE CLUSTER GROUP g2 CLUSTER MEMBER g2n1 HOST '192.168.0.21' PORT 10210;
  - (X) ALTER CLUSTER GROUP g1 ADD CLUSTER MEMBER g1n2 HOST '192.168.0.12' PORT 10120;
- Cluster object DDL and SQL object DDL
  - (X) CREATE CLUSTER GROUP g2 CLUSTER MEMBER g2n1 HOST '192.168.0.21' PORT 10210;
  - (X) CREATE TABLE t1 ( c1 INTEGER );
- SQL object DDL and SQL object DDL
  - (O) CREATE TABLE t1 ( c1 INTEGER );
  - (O) CREATE TABLE t2 ( a1 INTEGER );

## Processing SELECT in Cluster

Generally, a query processing of the cluster is similar to that of the stand alone. However, when the data exist on both a local server and a remote server, it is different that the cluster requests the query processing to a remote server and receives the result from it.

There are a sharded table and a cloned table (refer to **Cluster Table and Shard**) in a cluster environment, and each table data is stored in a local server and a remote server. The sharded table data is dividedly stored in a group, and its duplicated data is stored in members of the same group. The data is duplicated and

stored in every group and member of a cloned table.

The following figure describes a 3 x 2 GOLDILOCKS cluster and tables stored in that cluster.

**Figure 2** 3 x 2 cluster configuration and tables

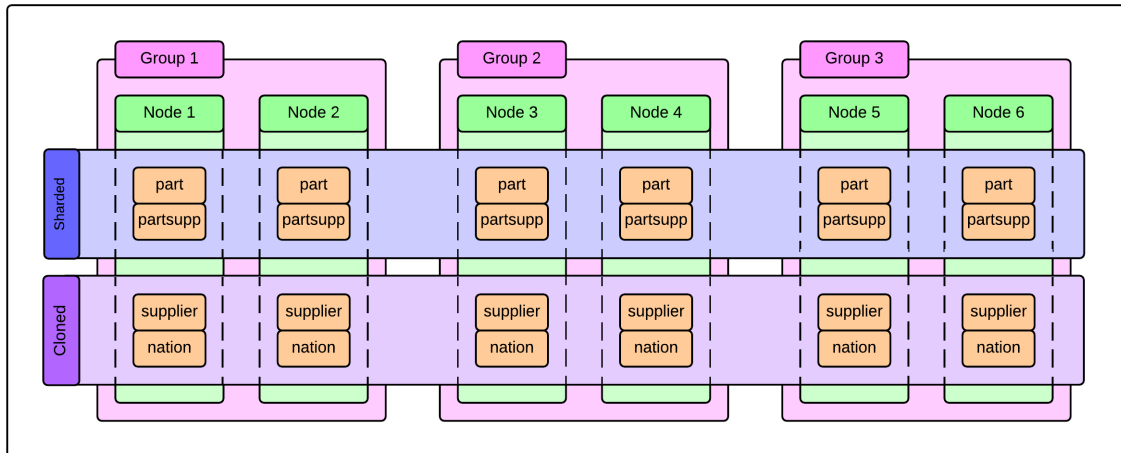

The following DDL creates the tables given above.

```
CREATE TABLE part
(
    p_partkey    INTEGER
, p_name       VARCHAR(55)
, p_brand      CHAR(10)
, p_type       VARCHAR(25)
, p_size       INTEGER
, p_retailprice NUMERIC(12,2)
, CONSTRAINT part_pk PRIMARY KEY( p_partkey ) INDEX part_pk_index
)
SHARDING BY HASH(p_partkey)
SHARD COUNT 3;
CREATE TABLE partsupp
(
    ps_partkey   INTEGER
, ps_suppkey   INTEGER
, ps_availqty  INTEGER
, ps_supplycost NUMERIC(12,2)
, CONSTRAINT partsupp_pk PRIMARY KEY( ps_partkey, ps_suppkey ) INDEX partsupp_pk_index
)
SHARDING BY HASH(ps_partkey)
SHARD COUNT 3;
CREATE TABLE supplier
(
```

```

    s_suppkey    INTEGER
  , s_name      CHAR(25)
  , s_nationkey INTEGER
  , s_phone     CHAR(15)
  , CONSTRAINT supplier_pk PRIMARY KEY( s_suppkey ) INDEX supplier_pk_index
) CLONED;
CREATE TABLE nation
(
    n_nationkey  INTEGER
  , n_name      CHAR(25)
) CLONED;

```

In the figure above, the part table and the partsupp table is a sharded table, and their data are dividedly stored per a group. The supplier table is a cloned table and its data is duplicated and stored in every node.

GOLDILOCKS in a cluster environment processes a query depending on the table type and the location of search target data. Cluster processes the query according to the method to collect the data and the method to manipulate the fetched data.

## Query Processing Method in a Cluster

A cluster should collect data from both a local server and a remote server to process a query. It creates SQL statement, delivers it to a local server and a remote server, then collects the results of query processing to collect the data.

The data is manipulated according to the statement type of the collected data. For example, the cluster query for *group by* statement is processed by grouping after collecting the data.

Collecting and manipulating data is performed by the plan node called as a cluster puller.

### Cluster Puller

Cluster puller node collects and manipulates the data.

- The data collection is a process to collect the data from multiple servers.
- The data manipulation is a process to create a new data based on the collected data.

The following is a process to perform the cluster puller.

Figure 3 Performing cluster puller

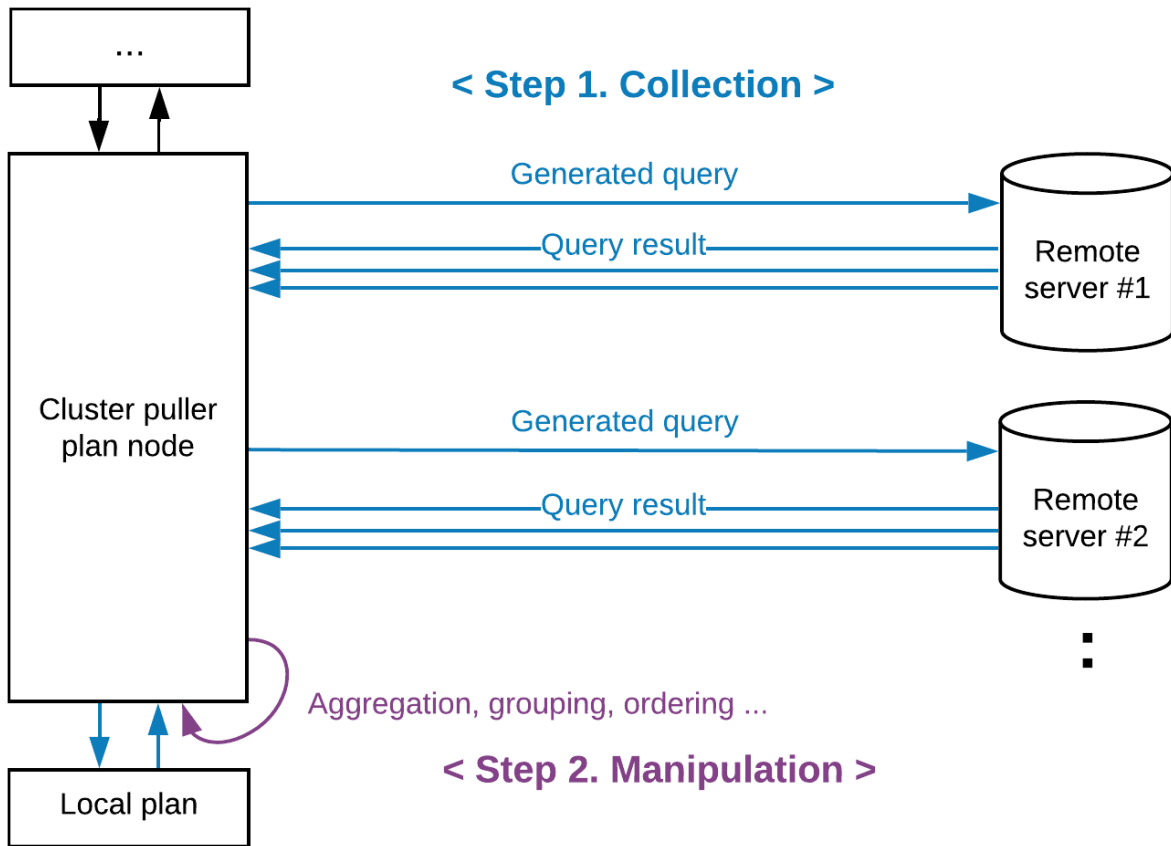

A cluster puller is classified according to the data fetching method from a local server and whether to distinguish a remote delivering server when fetching data from a remote server.

A cluster puller is divided into the following three plan nodes.

Table 12-7 Cluster puller node

| Cluster puller node | How to collect the local data               | How to collect the remote data                                                                    |
|---------------------|---------------------------------------------|---------------------------------------------------------------------------------------------------|
| Plan based cluster  | It performs a plan configured in the local. | It performs a generated query. (It collects the result without distinguishing the remote server.) |
| Single cluster      | It performs a generated query.              | It performs a generated query. (It collects the result without distinguishing the remote server.) |
| Multiple cluster    | It performs a generated query.              | It perform a generated query. (It collects the result by distinguishing the remote server.)       |

A generated query is configured to collect or update the data while performing a query provided by a user. For more information, refer to **Generated Query**.

Those paragraphs below describes how to collect the data per each feature in available in each cluster puller node and how to manipulate the data.

## How to Collect Data

- By pass: It collects the processed results in the delivered sequence.
- Merge sort: It sequentially collects the processed results according to the given order of sorting.

## How to Manipulate the Collected Data

- No manipulation: It does not manipulate the data.
- Aggregation: It aggregates the collected data.
- Grouping: It groups the collected data.
- Ordering: It orders for the collected data.
- Intersect key group: It classifies the collected data based on the delivering server, and groups each server data by a given key, then intersects them in group unit.
- Distinct key group: It classifies the collected data based on the delivering server, and groups each server data by a given key, then performs distinct on them in group unit.

## Cluster Puller Feature

The cluster puller node collects data from a local server or a remote server. It determines the server from which to collect the data, then fetches data by transferring a generated query.

The following is an example of retrieving a single table without *where* condition.

```
gSQL> \EXPLAIN PLAN SELECT c1 FROM t_shard_1;
C1
--
1
2
3
3 rows selected.
>>> start print plan
< Execution Plan >
=====
|  IDX  |  NODE DESCRIPTION  |  ROWS  |
-----|-----|-----|
|   0   |  SELECT STATEMENT  |        3 |
|   1   |  QUERY BLOCK ("QB_IDX_2") |        3 |
```

```

| 2 | PLAN BASED CLUSTER | LOCAL/REMOTE 3 |
| 3 | INDEX ACCESS ("T_SHARD_1", "IDX") | ( 1) 1 |
=====
1 - TARGET : T_SHARD_1.C1
2 - SQL : SELECT /*+ INDEX( _A1, "PUBLIC"."IDX" ) */ "_A1"."C1" FROM
"PUBLIC"."T_SHARD_1"@LOCAL AS "_A1"
      TARGET DOMAIN : G1(G1N1,G1N2) 1 rows, G2(G2N1,G2N2) 1 rows, G3(G3N1,G3N2) 1 rows
3 - RANGE SHARD ( # 3 )
      READ INDEX COLUMN : T_SHARD_1.C1
<<< end print plan

```

After performing the query, a plan based cluster is used as cluster puller. The plan based cluster in the execution plan above is a plan whose idx is 2 in <Execution Plan>.

The following information is output on ROWS field of the cluster puller.

- LOCAL ONLY n: The number of data fetched from a local server.
- REMOTE ONLY n: The number of data fetched from a remote server.
- LOCAL/REMOTE n: The total number of data fetched from a local server and a remote server.

The following is the detailed information about PLAN BASED CLUSTER.

- SQL: Generated query
- TARGET DOMAIN: The target group and the target member to transfer a generated query and the number of data fetched from the group

## Selecting Target Server to Perform in Cluster Puller

It analyzes the following information and selects the target to perform a generated query.

- Table replication placement strategy
- Cluster Domain
- Reducing Target Domain of Cluster Puller

It analyzes the information listed above for each table included in a generated query, and find a server in common, then selects it as a target server to perform the generated query. They are classified as target domains on the cluster puller node.

The following is a summary of the replication placement strategy of defined tables to describe **Generated Query**.

```

t_shard_1 (shard table) : at cluster group G1, G2, G3
t_shard_2 (shard table) : at cluster group G1, G3
t_clone_1 (cloned table) : at cluster group G1, G2, G3 (cluster wide)

```



`t_clone_2` (cloned table) : at cluster group G2, G3

The following is an example of selecting the execution target server according to the table replication placement strategy.

- Execution target server: All servers in G1, G3

`gSQL> SELECT c1 FROM t_shard_2;`

- Execution target server: All servers in G1, G2, G3

`gSQL> SELECT c1 FROM t_clone_1;`

- Execution target server: All servers in G1, G3 (Commonly included cluster group)

`gSQL> SELECT c1 FROM t_shard_2, t_clone_1;`

The following is an example of selecting the execution target server according to the description of the cluster domain.

- Execution target server: All servers in G1, G2, G3

`gSQL> SELECT c1 FROM t_shard_1@GLOBAL;`

- Execution target server: The server to which the user query was requested

`gSQL> SELECT c1 FROM t_shard_1@LOCAL;`

- Execution target server: All servers in G2

`gSQL> SELECT c1 FROM t_shard_1@G2;`

- Execution target server: G3N1 server

`gSQL> SELECT c1 FROM t_shard_1@G3N1;`

- Execution target server: Target server does not exist

`gSQL> SELECT c1 FROM t_shard_1@G4;`

The following is an example of selecting the execution target server according to the sharding key search condition.

- Execution target server: All servers in G1, G2, G3

```
gSQL> SELECT c1 FROM t_shard_1;
```

- Execution target server: All servers in G1, G2, G3

```
gSQL> SELECT c1 FROM t_shard_1 WHERE c1 = 1;
```

- Execution target server: All servers in G3

```
gSQL> SELECT c1 FROM t_shard_1 WHERE shard_key = 500;
```

- Execution target server: Target server does not exist

```
gSQL> SELECT c1 FROM t_shard_1 WHERE shard_key = 100 AND shard_key = 500;
```

It looks for servers in common through the table replication placement strategy and cluster domain, sharding key searching strategy when performing the generated query searching for the data. If multiple servers in the same cluster group are targets to perform, then the generated query is performed for only one accessible server per each cluster group considering the network condition of when it is performed.

The following is an example of selecting a target server to perform.

- Table replication placement strategy: All servers in G1, G2, G3
- Cluster domain
- t\_shard\_1: All servers in G2
- t\_clone\_1: All servers in G1, G2, G3
- join: All servers in G1, G2, G3
- Sharding key searching strategy: All servers in G2
- Target servers to perform the generated query: A single server in G2

```
gSQL> \EXPLAIN PLAN ONLY SELECT * FROM t_shard_1@G2, t_clone_1 WHERE t_shard_1.shard_key = 300;
```

```
>>> start print plan
```

```
< Execution Plan >
```

| IDX | NODE DESCRIPTION         | ROWS |
|-----|--------------------------|------|
| 0   | SELECT STATEMENT         | 0    |
| 1   | QUERY BLOCK ("QB_IDX_2") | 0    |
| 2   | PLAN BASED CLUSTER       | 0    |
| 3   | NESTED JOIN (INNER JOIN) | 0    |

```

| 4 |          TABLE ACCESS ("T_SHARD_1")          |          0 |
| 5 |          TABLE ACCESS ("T_CLONE_1")          |          0 |
=====
1 - TARGET : T_SHARD_1.SHARD_KEY, T_SHARD_1.C1, T_CLONE_1.C1
2 - SQL : SELECT /*+ KEEP_JOINED_TABLE USE_NL_IN( _A1 ) FULL( _A2 ) FULL( _A1 ) */
"_A2"."SHARD_KEY", "_A2"."C1", "_A1"."C1" FROM ( "PUBLIC"."T_SHARD_1"@LOCAL AS "_A2" INNER
JOIN "PUBLIC"."T_CLONE_1"@LOCAL AS "_A1" ON true ) ALIAS "_A3" WHERE "_A2"."SHARD_KEY" = :_V0
      TARGET DOMAIN : G2(G2N1,G2N2) 0 rows
3 - JOINED COLUMN : T_SHARD_1.SHARD_KEY, T_SHARD_1.C1, T_CLONE_1.C1
4 - RANGE SHARD ( # 3 )
      READ COLUMN : T_SHARD_1.SHARD_KEY, T_SHARD_1.C1
      PHYSICAL FILTER : T_SHARD_1.SHARD_KEY = 300
5 - CLONED
      READ COLUMN : T_CLONE_1.C1
<<< end print plan

```

## Utilizing Cluster Puller

It selects a cluster puller node according to the data manipulation method. If the data manipulation is not required, then it can use a plan based cluster or a single cluster. If the ordering for the results are required, then it uses multiple clusters. The data collection method is determined according to the data manipulation method.

**Table 12-8** Features supported by cluster puller node

| Cluster            | How to collect the data | How to manipulate the data                                        |
|--------------------|-------------------------|-------------------------------------------------------------------|
| Plan based cluster | By pass                 | No manipulation                                                   |
| Single cluster     | By pass                 | No manipulation<br>Aggregation<br>Grouping                        |
| Multiple cluster   | Merge sort              | Ordering<br>Grouping<br>Intersect key group<br>Distinct key group |

## Cluster Puller Plan Node

The cluster puller plan node is classified according to the data collection method from a local server and a remote server. For more information about the classification of cluster puller plan nodes according to the data collection, refer to **Cluster Puller Plan Node**.

## Plan Based Cluster

It collects the execution results in an order received from the data collection phase.

- Collecting local data: It performs the plan configured in local.
- Collecting remote data: It performs the generated query.

It does not manipulate anything except for applying a filter to the collected data. (No manipulation)

The following is an example of performing the plan based cluster.

Figure 4 Plan based cluster

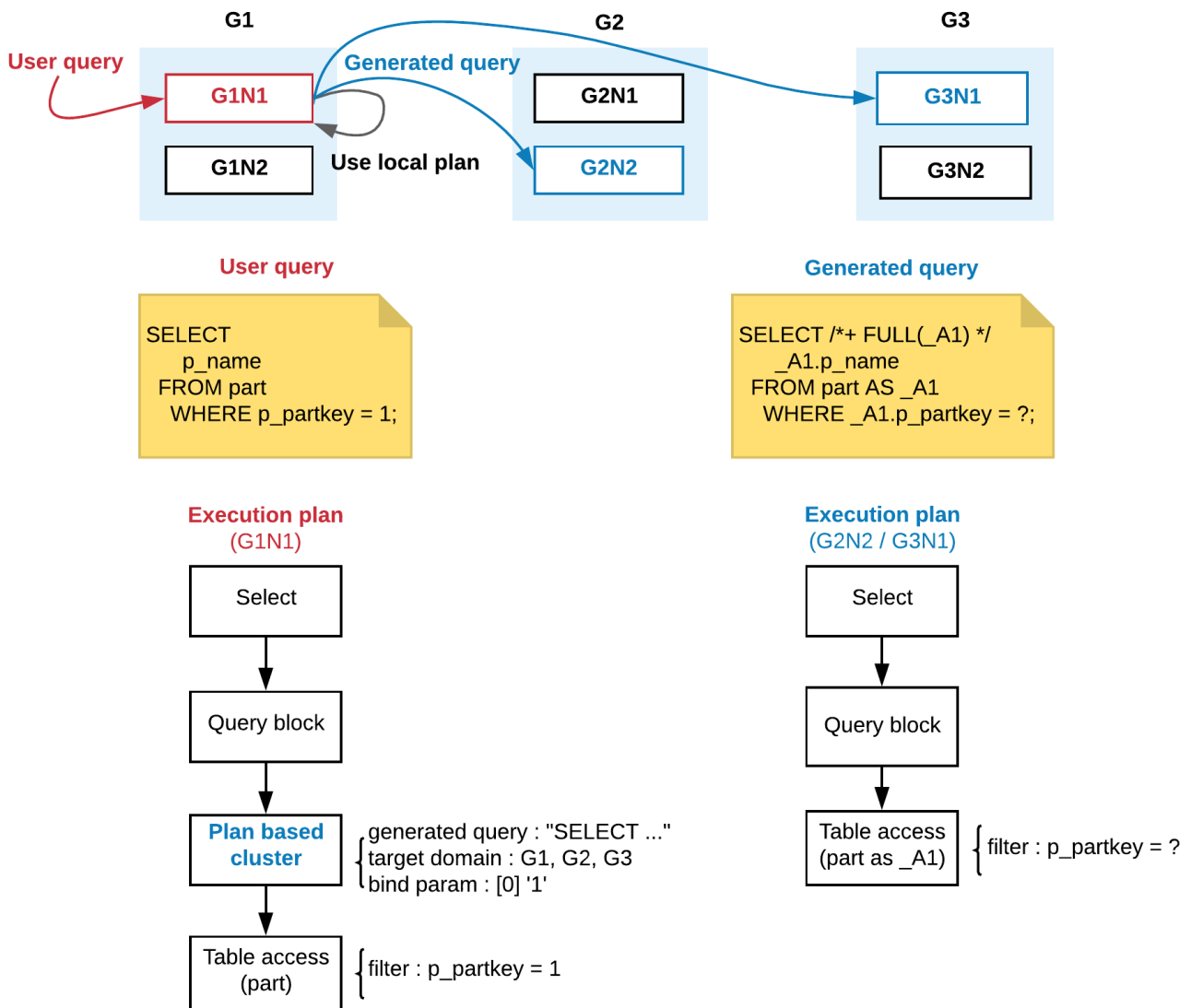

## Single Cluster

It collects the execution results in an order received from the data collection phase.

- Collecting local data: It performs the generated query.
- Collecting remote data: It performs the generated query.

A single cluster supports the following data manipulation methods.

- No manipulation
- Aggregation
- Grouping

The following is an example of performing a single cluster.

Figure 5 Single cluster

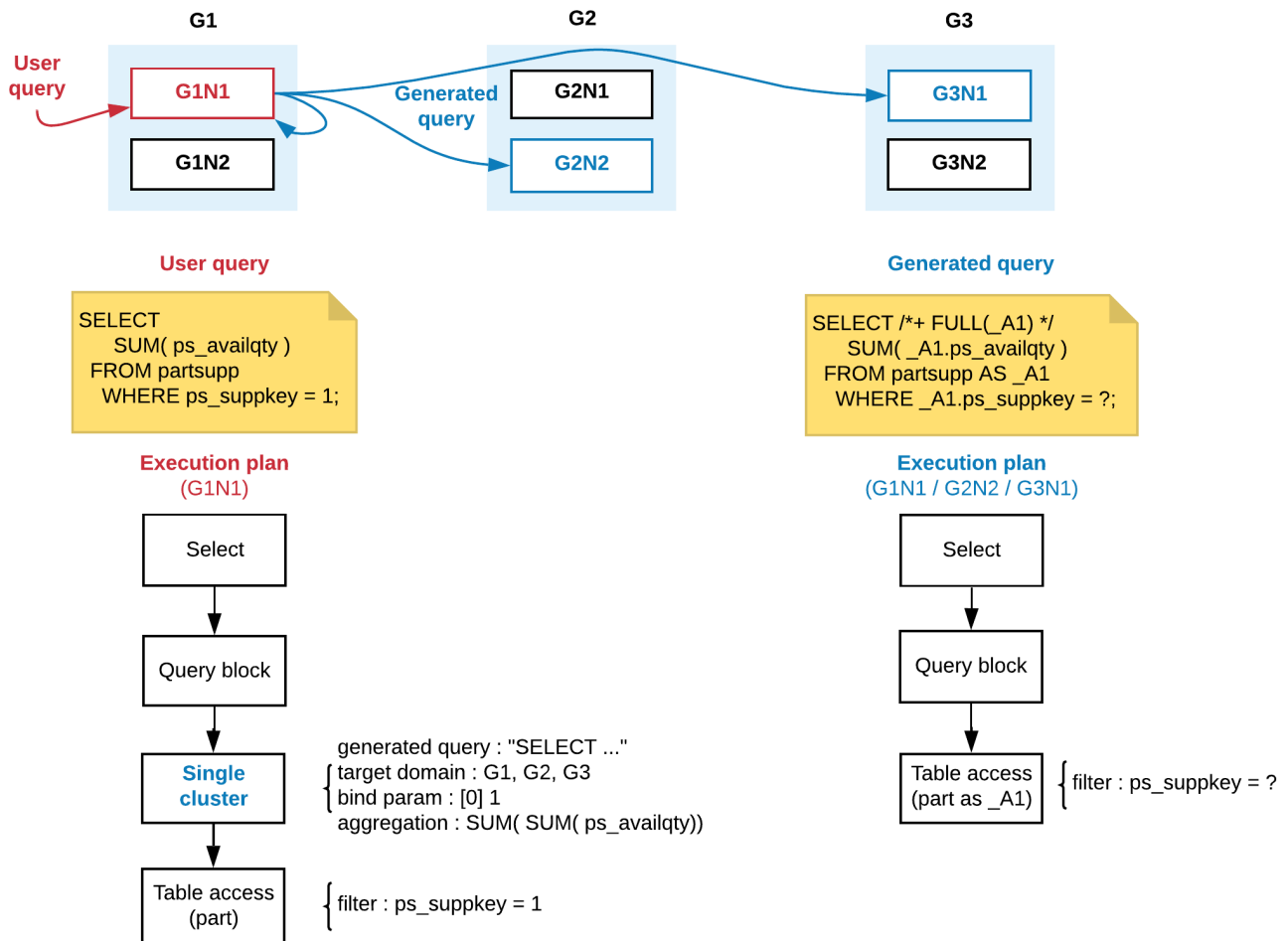

## Multiple Clusters

Multiple clusters perform the generated query by using each different cluster executor per group. They collect data by performing merge sort the data received with all cluster executors on the data collection phase.

- Collecting local data: It performs the generated query.
- Collecting remote data: It performs the generated query.

Multiple clusters support the following data manipulation methods.

- Ordering
- Grouping
- Intersect key group
- Distinct key group

The following is an example of performing multiple clusters.

Figure 6 Multiple clusters

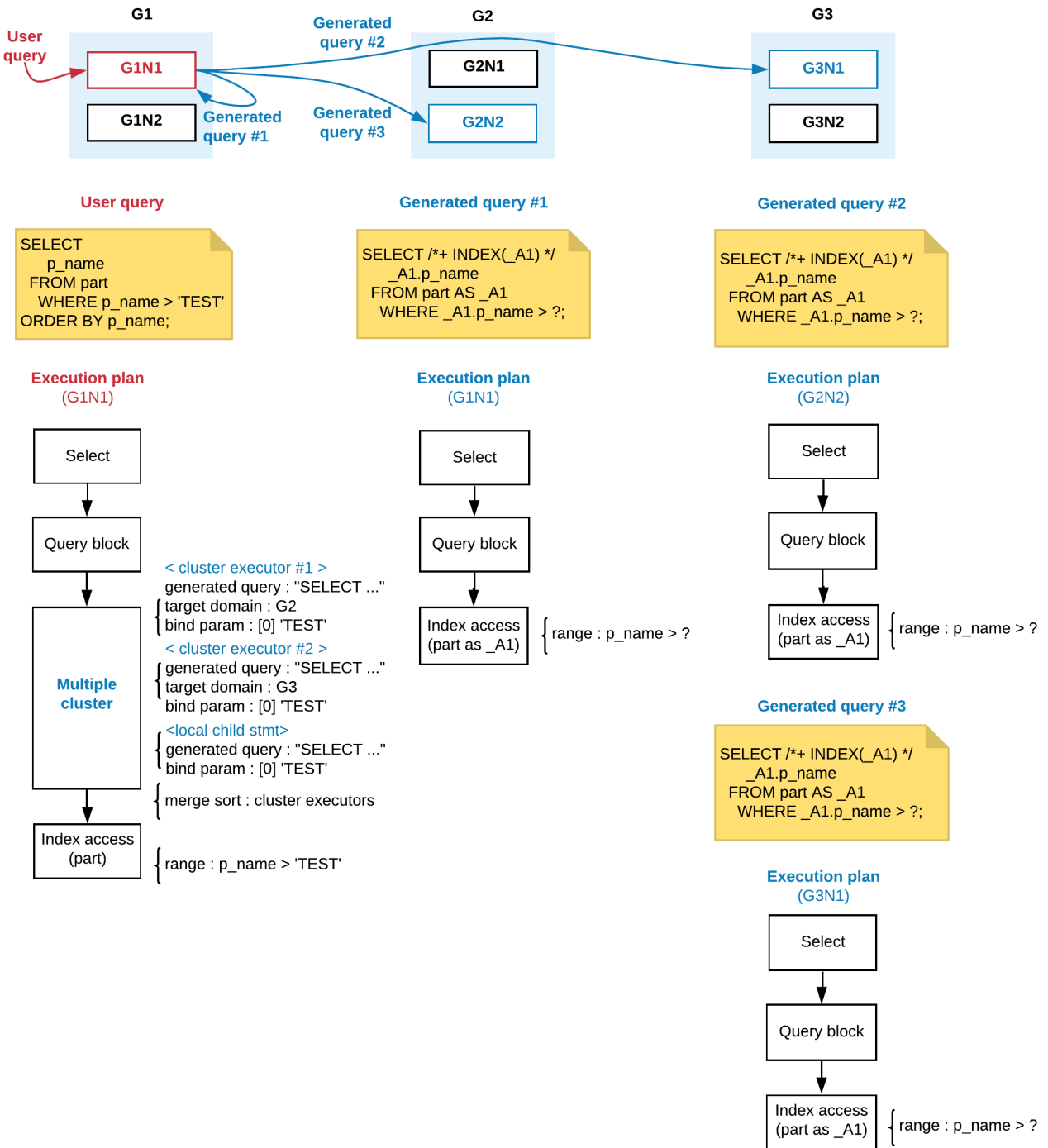

## Cluster Domain

Cluster domain collects data only from limited servers in cluster environment. For example, if it queries as follows by setting the cluster group corresponding to employees in a specific range as a cluster domain, then it can find specific employees from the sharded table which consists of salary class.

- It configures a sharded table per a salary class.

```
gSQL> CREATE TABLE t1( name VARCHAR(128), salary INTEGER )
      SHARDING BY RANGE( salary )
          SHARD s1 VALUES LESS THAN ( 200 )      AT CLUSTER GROUP G1,
          SHARD s2 VALUES LESS THAN ( 400 )      AT CLUSTER GROUP G2,
          SHARD s3 VALUES LESS THAN ( MAXVALUE ) AT CLUSTER GROUP G3;
```

Table created.

```
gSQL> INSERT INTO t1 VALUES ( 'A', 500 );
```

1 row created.

```
gSQL> INSERT INTO t1 VALUES ( 'B', 100 );
```

1 row created.

```
gSQL> INSERT INTO t1 VALUES ( 'C', 300 );
```

1 row created.

- It searches for employees in a specific salary range.

```
gSQL> SELECT name, salary FROM t1@G2;
```

```
NAME SALARY
```

```
-----
```

```
C      300
```

1 row selected.

Cluster domain is defined by targeting a table or a view specified in **from clause** and referring to **<cluster domain>**, and one of the followings can be selected.

- Cluster member performing a user query
- Cluster member performing a user query targeting offline table
- All cluster groups
- A cluster group
- A cluster member

When a cluster member is selected as a cluster domain, then it accesses the corresponding server, then collects data. If the server does not have the data distribution for the target table, then the query result does not exist.

It supports *@LOCAL\_OFFLINE* cluster domain to retrieve the offline table data from the server to which th

e user is connected. If the table is online, then an error occurs.

If a cluster group is selected as a cluster domain, then it has the data distribution for the corresponding table in the group, and it collects data by accessing a server which can communicate with. If an accessible server does not exist, then the query result does not exist.

If all cluster groups are selected as a cluster domain, then data from each cluster group are collected and transferred to a user.

A cluster domain can not be used to determine the data update target. In other words, <cluster domain> can not be applied to a target table of DML.

A cluster domain for a target table of DML causes a syntax error as follows.

```
gSQL> INSERT INTO t1@LOCAL VALUES ( 1 );
ERR-42000(16062): syntax error :
INSERT INTO t1@LOCAL VALUES ( 1 )
          *
ERROR at line 1:
gSQL> UPDATE t1@GLOBAL SET c1 = 1;
ERR-42000(16062): syntax error :
UPDATE t1@GLOBAL SET c1 = 1
          *
ERROR at line 1:
gSQL> DELETE FROM t1@G1;
ERR-42000(16062): syntax error :
DELETE FROM t1@G1
          *
ERROR at line 1:
```

A cluster domain for a target table of SELECT FOR UPDATE causes a syntax error as follows.

- Cluster domain for the data collection target

```
gSQL> SELECT c1 FROM t1@LOCAL;
I1
--
1
1 row selected.
```

- Cluster domain for the data update target

```
gSQL> SELECT c1 FROM t1@LOCAL FOR UPDATE;
ERR-42000(16062): syntax error :
```



```
SELECT c1 FROM t1@LOCAL FOR UPDATE
          *
ERROR at line 1:
```

## Reducing Target Domain of Cluster Puller

The methods to reduce the target domain to be processed by transferring a generated query are as follows.

- **Cluster Domain:** It reduces the target domain by specifying the domain.
- **Shard key filter:** It reduces the target domain by providing the sharding key condition.
- **Rowinfo domain filter:** It reduces the target domain by providing the pseudo column condition related to a table.

The combination of the shard key filter and the rowinfo domain filter is called as the domain filter.

The following is an example of retrieving a single table by specifying the retrieving target domain in the table.

```
gSQL> \EXPLAIN PLAN SELECT c1 FROM t_shard_1@G2;
C1
--
 2
1 row selected.
>>> start print plan
< Execution Plan >
=====
|  IDX  |  NODE DESCRIPTION  |  ROWS  |
-----|-----|-----|
|   0   |  SELECT STATEMENT  |         1 |
|   1   |    QUERY BLOCK ("SQB_IDX_2")  |         1 |
|   2   |    PLAN BASED CLUSTER  |  REMOTE ONLY  1 |
|   3   |    INDEX ACCESS ("T_SHARD_1", "IDX")  | ( 0)  0 |
=====
 1 - TARGET : T_SHARD_1.C1
 2 - SQL : SELECT /*+ INDEX( _A1, "PUBLIC"."IDX" ) */ "_A1"."C1" FROM
"PUBLIC"."T_SHARD_1"@LOCAL AS "_A1"
      TARGET DOMAIN : G2(G2N1,G2N2) 1 rows
 3 - RANGE SHARD ( # 3 )
      READ INDEX COLUMN : T_SHARD_1.C1
<<< end print plan
```

When the retrieving target domain is specified, then TARGET DOMAIN is reduced to G2 as in the example.

see above. For more information about domain, refer to **Cluster Domain**.

The following is an example of restricting TARGET DOMAIN by adding the shard key condition on where clause.

```
gSQL> \EXPLAIN PLAN SELECT c1 FROM t_shard_1 WHERE shard_key = 555;
C1
--
 3
1 row selected.
>>> start print plan
< Execution Plan >
=====
|  IDX  |  NODE DESCRIPTION  |  ROWS  |
-----|-----|-----|
|   0   |  SELECT STATEMENT  |        |
|   1   |  QUERY BLOCK ("QB_IDX_2") |        |
|   2   |  PLAN BASED CLUSTER | REMOTE ONLY |
|   3   |  TABLE ACCESS ("T_SHARD_1") |        |
=====
1 - TARGET : T_SHARD_1.C1
2 - SQL : SELECT /*+ FULL( _A1 ) */ "_A1"."C1" FROM "PUBLIC"."T_SHARD_1"@LOCAL AS "_A1"
WHERE "_A1"."SHARD_KEY" = :_V0
TARGET DOMAIN : G3(G3N1,G3N2) 1 rows
3 - RANGE SHARD ( # 3 )
   READ COLUMN : T_SHARD_1.SHARD_KEY, T_SHARD_1.C1
   PHYSICAL FILTER : T_SHARD_1.SHARD_KEY = 555
<<< end print plan
```

When the shard key condition which has a constant value is added, then TARGET DOMAIN is reduced as in the example above.

The retrieving target group can be restricted by using the shard key condition. The shard key condition which has a constant value can determine the retrieving target while configuring the plan. The shard key condition which is not a constant value determines the retrieving target group at the time of executing the query.

In other words, adding the shard key condition which is not a constant value does not reduce TARGET DOMAIN. Instead, SHARD KEY FILTER condition which is the information to determine the domain is configured at the time of executing the query.

The following is an example of restricting TARGET DOMAIN by adding the shard key condition which is not a constant value to where clause.

```

gSQL> VAR V1 INTEGER
gSQL> EXEC :V1 := 555
gSQL> \EXPLAIN PLAN SELECT c1 FROM t_shard_1 WHERE shard_key = :V1;
C1
--
3
1 row selected.
>>> start print plan
< Execution Plan >
=====
|  IDX  |  NODE DESCRIPTION          |  ROWS  |
-----|-----|-----|
|   0   |  SELECT STATEMENT          |        |
|   1   |  QUERY BLOCK ("$_QB_IDX_2") |        |
|   2   |  PLAN BASED CLUSTER        | REMOTE ONLY |
|   3   |  TABLE ACCESS ("T_SHARD_1") |         0 |
=====

1 - TARGET : T_SHARD_1.C1
2 - SQL : SELECT /*+ FULL( _A1 ) */ "_A1"."C1" FROM "PUBLIC"."T_SHARD_1"@LOCAL AS "_A1"
WHERE "_A1"."SHARD_KEY" = :_V0
      TARGET DOMAIN : G1(G1N1,G1N2) 0 rows, G2(G2N1,G2N2) 0 rows, G3(G3N1,G3N2) 1 rows
      SHARD KEY FILTER : ( T_SHARD_1.SHARD_KEY = :V1 )
3 - RANGE SHARD ( # 3 )
   READ COLUMN : T_SHARD_1.SHARD_KEY, T_SHARD_1.C1
   PHYSICAL FILTER : T_SHARD_1.SHARD_KEY = :V1
<<< end print plan

```

TARGET DOMAIN can also be reduced by providing the **Pseudo Columns** condition related to the table. It can be used as a domain filter only when using equal (=) condition for the pseudo column.

**Table 12-9** Pseudo column which can be used as the domain filter

| Pseudo column      | Whether to use the pseudo column as the domain filter |
|--------------------|-------------------------------------------------------|
| CURRVAL            | Not available                                         |
| NEXTVAL            | Not available                                         |
| ROWNUM             | Not available                                         |
| ROWID              | Available                                             |
| CLUSTER_GROUP_ID   | Available                                             |
| CLUSTER_MEMBER_ID  | Available                                             |
| CLUSTER_GROUP_NAME | Available                                             |
| CLUSTER_NAME_ID    | Available                                             |
| CLUSTER_SHARD_ID   | Available                                             |

The following is an example of restricting TARGET DOMAIN by adding the pseudo column condition.

```
gSQL> \EXPLAIN PLAN SELECT c1 FROM t_shard_1 WHERE cluster_group_name = 'G3';
C1
--
3
1 row selected.
>>> start print plan
< Execution Plan >
=====
|  IDX  |  NODE DESCRIPTION          |  ROWS  |
-----|-----|-----|
|   0   |  SELECT STATEMENT          |        |
|   1   |  QUERY BLOCK ("$_QB_IDX_2") |        |
|   2   |  PLAN BASED CLUSTER        | REMOTE ONLY |
|   3   |  INDEX ACCESS ("T_SHARD_1", "IDX") | ( 0) 0 |
=====
1 - TARGET : T_SHARD_1.C1
2 - SQL : SELECT /*+ INDEX( _A1, "PUBLIC"."IDX" ) */ "_A1"."C1" FROM
"PUBLIC"."T_SHARD_1"@LOCAL AS "_A1" WHERE "_A1"."CLUSTER_GROUP_NAME" = :_V0
TARGET DOMAIN : G3(G3N1,G3N2) 1 rows
3 - RANGE SHARD ( # 3 )
   READ INDEX COLUMN : T_SHARD_1.C1
   LOGICAL KEY FILTER : T_SHARD_1.CLUSTER_GROUP_NAME = 'G3'
<<< end print plan
```

The pseudo column condition using the constant value reduces TARGET DOMAIN.

The following is an example of using the pseudo column condition which is not a constant value.

```
gSQL> VAR V1 VARCHAR( 10 )
gSQL> EXEC :V1 := 'G3N1'
gSQL> \EXPLAIN PLAN SELECT c1 FROM t_shard_1 WHERE cluster_member_name = :V1;
C1
--
3
1 row selected.
>>> start print plan
< Execution Plan >
=====
|  IDX  |  NODE DESCRIPTION          |  ROWS  |
-----|-----|-----|
```

```

0	SELECT STATEMENT		1
1	QUERY BLOCK ("$_QB_IDX_2")		1
2	PLAN BASED CLUSTER	REMOTE ONLY	1
3	INDEX ACCESS ("T_SHARD_1", "IDX")	( 0 )	0
=====
1 - TARGET : T_SHARD_1.C1
2 - SQL : SELECT /*+ INDEX( _A1, "PUBLIC"."IDX" ) */ "_A1"."C1" FROM
"PUBLIC"."T_SHARD_1"@LOCAL AS "_A1" WHERE "_A1"."CLUSTER_MEMBER_NAME" = :_V0
      TARGET DOMAIN : G1(G1N1,G1N2) 0 rows, G2(G2N1,G2N2) 0 rows, G3(G3N1,G3N2) 1 rows
      ROWINFO DOMAIN FILTER : T_SHARD_1.CLUSTER_MEMBER_NAME = :V1
3 - RANGE SHARD ( # 3 )
      READ INDEX COLUMN : T_SHARD_1.C1
      LOGICAL KEY FILTER : T_SHARD_1.CLUSTER_MEMBER_NAME = :V1
<<< end print plan

```

Adding the pseudo column condition which is not a constant value does not reduce TARGET DOMAIN. Instead, ROWINFO DOMAIN FILTER condition which is the information to determine the domain is configured at the time of execution.

## Generated Query

The generated query is generated to refer to or to update the data in another server when processing a query given by a user.

```
SELECT c1 FROM t1;
```

When the query is given by a user as above, then the server to which the query is given generates a similar generated query to collect the t1 data from all related cluster groups as follows.

```
SELECT c1 FROM t1@LOCAL;
```

The following example table is configured to describe the generated query.

```

CREATE TABLE t_shard_1( shard_key INTEGER, c1 INTEGER )
      SHARDING BY RANGE( shard_key )
      SHARD s1 VALUES LESS THAN ( 200 )          AT CLUSTER GROUP G1,
      SHARD s2 VALUES LESS THAN ( 400 )          AT CLUSTER GROUP G2,
      SHARD s3 VALUES LESS THAN ( MAXVALUE ) AT CLUSTER GROUP G3;
CREATE TABLE t_shard_2( shard_key INTEGER, c1 INTEGER )
      SHARDING BY RANGE( shard_key )
      SHARD s1 VALUES LESS THAN ( 300 )          AT CLUSTER GROUP G1,
      SHARD s2 VALUES LESS THAN ( MAXVALUE ) AT CLUSTER GROUP G3;

```

```
CREATE TABLE t_clone_1( c1 INTEGER ) CLONED AT CLUSTER WIDE;
CREATE TABLE t_clone_2( c1 INTEGER ) CLONED AT CLUSTER GROUP G2, G3;
```

The generated query is a query which was configured again based on the cluster puller plan node.

Each cluster puller plan node configures the generated query for **data collection method** according to **Utilizing Cluster Puller**.

## Generated Query for No Manipulation

When the collected data is not manipulated, then the plan based cluster or the single cluster is used as the cluster puller plan node.

The generated query is configured and output on the explain plan result for the cluster puller plan node which does not manipulate the data, but the information about manipulation is not output.

The following is an example of no manipulation using the plan based cluster.

```
gSQL> \EXPLAIN PLAN SELECT c1 FROM t_shard_1;
C1
--
 1
 3
 2
3 rows selected.
>>> start print plan
< Execution Plan >
=====
|  IDX  |  NODE DESCRIPTION                               |                ROWS |
-----|-----|-----|
|   0   |  SELECT STATEMENT                               |                    3 |
|   1   |    QUERY BLOCK ("$_QB_IDX_2")                   |                    3 |
|   2   |      PLAN BASED CLUSTER                         | LOCAL/REMOTE    3 |
|   3   |        TABLE ACCESS ("T_SHARD_1")              |                    1 |
=====
 1 - TARGET : T_SHARD_1.C1
 2 - SQL : SELECT /**+ FULL( _A1 ) */ "_A1"."C1" FROM "PUBLIC"."T_SHARD_1"@LOCAL AS "_A1"
      TARGET DOMAIN : G1(G1N1,G1N2) 1 rows, G2(G2N1,G2N2) 1 rows, G3(G3N1,G3N2) 1 rows
 3 - RANGE SHARD ( # 3 )
      READ COLUMN : T_SHARD_1.C1
<<< end print plan
```

The following is an example of no manipulation using a single cluster.

```
gSQL> \EXPLAIN PLAN SELECT t_shard_1.c1 FROM t_shard_1, t_shard_2 WHERE t_shard_1.shard_key =
t_shard_2.c1;
```

```
C1
```

```
--
```

```
1
```

```
2
```

```
2 rows selected.
```

```
>>> start print plan
```

```
< Execution Plan >
```

```
=====
```

| IDX | NODE DESCRIPTION                     | ROWS           |
|-----|--------------------------------------|----------------|
| 0   | SELECT STATEMENT                     | 2              |
| 1   | QUERY BLOCK ("SQB_IDX_2")            | 2              |
| 2   | SINGLE CLUSTER                       | LOCAL/REMOTE 2 |
| 3   | CLUSTER PUSHER ("_NI_6")             | 3              |
| 4   | PLAN BASED CLUSTER                   | LOCAL/REMOTE 3 |
| 5   | TABLE ACCESS ("T_SHARD_2")           | 2              |
| 6   | SELECT STATEMENT                     | 0              |
| 7   | QUERY BLOCK ("SQB_IDX_2")            | 0              |
| 8   | NESTED JOIN (INNER JOIN)             | 0              |
| 9   | TABLE ACCESS ("T_SHARD_1" AS _A2)    | 1              |
| 10  | PUSHER TABLE ACCESS ("_NI_6" AS _A1) | 0              |

```
=====
```

```
1 - TARGET : T_SHARD_1.C1
```

```
2 - SQL : SELECT /*+ KEEP_JOINED_TABLE USE_NL_IN( _A1 ) FULL( _A2 ) FULL( _A1 ) */
_A2"."C1" FROM ( "PUBLIC"."T_SHARD_1"@LOCAL AS "_A2" INNER JOIN
"SESSION_SCHEMA"."_NI_6"@LOCAL AS "_A1" ON "_A2"."SHARD_KEY" = "_A1"."C1") ALIAS "_A3"
```

```
TARGET DOMAIN : G1(G1N1,G1N2) 1 rows, G2(G2N1,G2N2) 1 rows, G3(G3N1,G3N2) 0 rows
```

```
3 - SQL : DECLARE INSTANT TABLE "SESSION_SCHEMA"."_NI_6" ( "C1" NUMBER(10, 0) )
```

```
COLUMN : T_SHARD_2.C1 AS C1
```

```
SHARDED : T_SHARD_2.C1
```

```
TARGET DOMAIN : G1(G1N1,G1N2) 1 rows, G2(G2N1,G2N2) 2 rows, G3(G3N1,G3N2) 0 rows
```

```
4 - SQL : SELECT /*+ FULL( _A1 ) */ "_A1"."C1" FROM "PUBLIC"."T_SHARD_2"@LOCAL AS "_A1"
```

```
TARGET DOMAIN : G1(G1N1,G1N2) 1 rows, G3(G3N1,G3N2) 2 rows
```

```
5 - RANGE SHARD ( # 4 )
```

```
READ COLUMN : T_SHARD_2.C1
```

```
7 - TARGET : _A2.C1
```

```
8 - JOINED COLUMN : _A2.SHARD_KEY, _A1.C1, _A2.C1
```

```
ON FILTER : _A2.SHARD_KEY = _A1.C1
```

```
9 - RANGE SHARD ( # 3 )
```

```

          READ COLUMN : _A2.SHARD_KEY, _A2.C1
10  -  READ COLUMN : _A1.C1
<<<  end print plan

```

## Generated Query for Aggregation

The generated query for aggregation supports aggregation per each group. It aggregates the data collected through the generated query again, then configures the final result.

**Table 12-10** How to manipulate aggregation data

| Aggregation in user query | Operation form included in the generated query | Operation for the aggregation result |
|---------------------------|------------------------------------------------|--------------------------------------|
| COUNT()                   | COUNT()                                        | SUM( COUNT() )                       |
| SUM()                     | SUM()                                          | SUM( SUM() )                         |
| AVG()                     | COUNT(), SUM()                                 | SUM( SUM() ) / SUM( COUNT() )        |
| MIN()                     | MIN()                                          | MIN( MIN() )                         |
| MAX()                     | MAX()                                          | MAX( MAX() )                         |

The generated query configures a query including COUNT operation to process COUNT operation of the user query. It gathers the data collected through the generated query, and accumulates COUNT results per each group. The accumulated value of COUNT result for every group becomes the result of user COUNT operation.

The following is an example of an aggregation using a single cluster.

```

gSQL> \EXPLAIN PLAN SELECT COUNT( c1 ) FROM t_shard_1;
COUNT( C1 )
-----
          3
1 row selected.
>>> start print plan
< Execution Plan >
=====
|  IDX  |  NODE DESCRIPTION                               |          ROWS |
|-----|-----|-----|
|   0   |  SELECT STATEMENT                               |               |
|   1   |    QUERY BLOCK (" $QB_IDX_2" )                 |               |
|   2   |      SINGLE CLUSTER                             | LOCAL/REMOTE 1 |
|   3   |        SELECT STATEMENT                         |               |
|   4   |          QUERY BLOCK (" $QB_IDX_2" )           |               |
|   5   |            TABLE ACCESS ("T_SHARD_1" AS _A1) |               |
=====

```



```

1 - TARGET : COUNT( T_SHARD_1.C1 )
2 - SQL : SELECT /*+ FULL( _A1 ) */ COUNT( "_A1"."C1" ) FROM "PUBLIC"."T_SHARD_1"@LOCAL
AS "_A1"
      TARGET DOMAIN : G1(G1N1,G1N2) 1 rows, G2(G2N1,G2N2) 1 rows, G3(G3N1,G3N2) 1 rows
      RE-AGGREGATION
      AGGREGATION : SUM( COUNT( T_SHARD_1.C1 ) )
4 - TARGET : COUNT( _A1.C1 )
5 - RANGE SHARD ( # 3 )
      READ COLUMN : _A1.C1
      AGGREGATION : COUNT( _A1.C1 )
<<< end print plan

```

When DISTINCT is specified in the aggregation operation as if COUNT( DISTINCT c1 ), then the generated query including the aggregation can not be configured, and the cluster puller plan node does not support the data manipulation related to the aggregation.

The following is an example of COUNT( DISTINCT ) operation.

```

gSQL> \EXPLAIN PLAN SELECT COUNT( DISTINCT c1 ) FROM t_shard_1;
COUNT( DISTINCT C1 )
-----
              3
1 row selected.
>>> start print plan
< Execution Plan >
=====
|  IDX  |  NODE DESCRIPTION                               |          ROWS |
-----|-----|-----|
|   0   |  SELECT STATEMENT                               |              1 |
|   1   |    QUERY BLOCK ("$_QB_IDX_2")                   |              1 |
|   2   |      AGGREGATION BY HASH                        |              1 |
|   3   |        PLAN BASED CLUSTER                       | LOCAL/REMOTE 3 |
|   4   |          TABLE ACCESS ("T_SHARD_1")            |              1 |
=====
1 - TARGET : COUNT( DISTINCT T_SHARD_1.C1 )
2 - DISTINCT AGGREGATION : COUNT( DISTINCT T_SHARD_1.C1 )
3 - SQL : SELECT /*+ FULL( _A1 ) */ "_A1"."C1" FROM "PUBLIC"."T_SHARD_1"@LOCAL AS "_A1"
      TARGET DOMAIN : G1(G1N1,G1N2) 1 rows, G2(G2N1,G2N2) 1 rows, G3(G3N1,G3N2) 1 rows
4 - RANGE SHARD ( # 3 )
      READ COLUMN : T_SHARD_1.C1
<<< end print plan

```

When the aggregation including DISTINCT is used, the generated query of the cluster puller does not include the aggregation. The data collected by the cluster puller performs the aggregation operation through separate plan node.

## Generated Query for Grouping

The generated query for grouping performs grouping per each group. It groups the data collected through the generated query again.

HAVING condition is applied after the grouping is completed on the cluster puller plan node.

The following is an example of grouping on the cluster puller plan node.

```
gSQL> \EXPLAIN PLAN SELECT COUNT( c1 ) FROM t_shard_1 AS A GROUP BY c1 HAVING MIN( shard_key )
> 1;
COUNT( C1 )
-----
          1
          1
          1
3 rows selected.
>>> start print plan
< Execution Plan >
=====
|  IDX  |  NODE DESCRIPTION                               |  ROWS  |
-----|-----|-----|
|   0   |  SELECT STATEMENT                               |        3 |
|   1   |  QUERY BLOCK ("$_QB_IDX_2")                     |        3 |
|   2   |  SINGLE CLUSTER                                | LOCAL/REMOTE 3 |
|   3   |  SELECT STATEMENT                               |        1 |
|   4   |  QUERY BLOCK ("$_QB_IDX_2")                     |        1 |
|   5   |  GROUP HASH INSTANT                             |        1 |
|   6   |  TABLE ACCESS ("T_SHARD_1" AS _A1)             |        1 |
=====
1 - TARGET : COUNT( A.C1 )
2 - SQL : SELECT /*+ USE_GROUP_HASH(100) FULL( _A1 ) */ "_A1"."C1", MIN(
"_A1"."SHARD_KEY" ), COUNT( "_A1"."C1" ) FROM "PUBLIC"."T_SHARD_1"@LOCAL AS "_A1" GROUP BY
"_A1"."C1"
TARGET DOMAIN : G1(G1N1,G1N2) 1 rows, G2(G2N1,G2N2) 1 rows, G3(G3N1,G3N2) 1 rows
RE-GROUPING
GROUP KEY : A.C1
AGGREGATION : MIN( MIN( A.SHARD_KEY ) ), SUM( COUNT( A.C1 ) )
PHYSICAL FILTER : MIN( A.SHARD_KEY ) > 1
```

```

4 - TARGET : _A1.C1, MIN( _A1.SHARD_KEY ), COUNT( _A1.C1 )
5 - GROUP KEY : _A1.C1
   RECORD COLUMN : MIN( _A1.SHARD_KEY ), COUNT( _A1.C1 )
   READ KEY COLUMN : _A1.C1
   READ RECORD COLUMN : MIN( _A1.SHARD_KEY ), COUNT( _A1.C1 )
6 - RANGE SHARD ( # 3 )
   READ COLUMN : _A1.SHARD_KEY, _A1.C1

```

```
<<< end print plan
```

The cluster puller plan node is determined according to **data collection method** grouped per group. When the data is collected in the way of by pass, a single cluster is used. When the data is collected in the way of merge sort, multiple clusters are used.

When using the preserved order of the subordinate node of the cluster puller plan node for grouping, the data is collected in the way of merge sort.

The following is an example of grouping which uses a single cluster.

```
gSQL> \EXPLAIN PLAN SELECT c1 FROM t_shard_1 AS A GROUP BY c1;
```

```
C1
```

```
--
```

```
1
```

```
2
```

```
3
```

```
3 rows selected.
```

```
>>> start print plan
```

```
< Execution Plan >
```

```

=====
IDX	NODE DESCRIPTION	ROWS
0	SELECT STATEMENT	3
1	QUERY BLOCK ("$_QB_IDX_2")	3
2	SINGLE CLUSTER	LOCAL/REMOTE 3
3	SELECT STATEMENT	1
4	QUERY BLOCK ("$_QB_IDX_2")	1
5	GROUP	1
6	INDEX ACCESS ("T_SHARD_1" AS _A1, "IDX")	(      1)    1
=====

```

```

1 - TARGET : A.C1
2 - SQL : SELECT /*+ INDEX( _A1, "PUBLIC"."IDX" ) */ "_A1"."C1" FROM
"PUBLIC"."T_SHARD_1"@LOCAL AS "_A1" GROUP BY "_A1"."C1"
   TARGET DOMAIN : G1(G1N1,G1N2) 1 rows, G2(G2N1,G2N2) 1 rows, G3(G3N1,G3N2) 1 rows

```

**RE-GROUPING**

```

      GROUP KEY : A.C1
4 - TARGET : _A1.C1
5 - GROUP KEY : _A1.C1
6 - RANGE SHARD ( # 3 )
      READ INDEX COLUMN : _A1.C1
<<< end print plan

```

The grouping which uses a single cluster can get the grouping result after all data is collected.

The following is an example of grouping which uses multiple clusters.

```
gSQL> \EXPLAIN PLAN SELECT /*+ MERGE_GROUP */ c1 FROM t_shard_1 AS A GROUP BY c1;
```

```
C1
```

```
--
```

```
1
```

```
2
```

```
3
```

```
3 rows selected.
```

```
>>> start print plan
```

```
< Execution Plan >
```

```

=====
|  IDX  |  NODE DESCRIPTION                               |          ROWS |
=====
0	SELECT STATEMENT	3
1	QUERY BLOCK ("$_QB_IDX_2")	3
2	MULTIPLE CLUSTER	LOCAL/REMOTE 3
3	SELECT STATEMENT	1
4	QUERY BLOCK ("$_QB_IDX_2")	1
5	GROUP	1
6	INDEX ACCESS ("T_SHARD_1" AS _A1, "IDX")	(      1)    1
=====

```

```
1 - TARGET : A.C1
```

```
2 - SQL : SELECT /*+ INDEX( _A1, "PUBLIC"."IDX" ) */ "_A1"."C1" FROM
"PUBLIC"."T_SHARD_1"@LOCAL AS "_A1" GROUP BY "_A1"."C1" ORDER BY "_A1"."C1" ASC NULLS LAST
      TARGET DOMAIN : G1(G1N1,G1N2) 1 rows, G2(G2N1,G2N2) 1 rows, G3(G3N1,G3N2) 1 rows
```

**MERGE GROUPING**

```

      SORT KEY : A.C1
      GROUP KEY : A.C1
4 - TARGET : _A1.C1
5 - GROUP KEY : _A1.C1
6 - RANGE SHARD ( # 3 )

```

```

      READ INDEX COLUMN : _A1.C1
<<< end print plan

```

The grouping which uses multiple clusters can get the grouping result after the data collection per grouping key is completed.

However, if all sharding keys are used as a grouping condition, then the cluster puller using no manipulation is configured. The cluster puller configures the generated query including grouping, and transfers the result to the superordinate plan without manipulating the collected data.

The following is an example of grouping with no manipulation when a user query includes GROUP BY statement.

```

gSQL> \EXPLAIN PLAN SELECT shard_key FROM t_shard_1 AS A GROUP BY shard_key;
SHARD_KEY
-----
      111
      555
      333
3 rows selected.
>>> start print plan
< Execution Plan >
=====
|  IDX  |  NODE DESCRIPTION  |  ROWS  |
-----|-----|-----|
|   0   |  SELECT STATEMENT  |        |
|   1   |  QUERY BLOCK ("$_QB_IDX_2") |        |
|   2   |  PLAN BASED CLUSTER | LOCAL/REMOTE |
|   3   |  GROUP HASH INSTANT |        |
|   4   |  TABLE ACCESS ("T_SHARD_1" AS A) |        |
=====
1 - TARGET : A.SHARD_KEY
2 - SQL : SELECT /*+ USE_GROUP_HASH(10) FULL( _A1 ) */ "_A1"."SHARD_KEY" FROM
"PUBLIC"."T_SHARD_1"@LOCAL AS "_A1" GROUP BY "_A1"."SHARD_KEY"
      TARGET DOMAIN : G1(G1N1,G1N2) 1 rows, G2(G2N1,G2N2) 1 rows, G3(G3N1,G3N2) 1 rows
3 - GROUP KEY : A.SHARD_KEY
      READ KEY COLUMN : A.SHARD_KEY
4 - RANGE SHARD ( # 3 )
      READ COLUMN : A.SHARD_KEY
<<< end print plan

```

## Generated Query for Ordering

The generated query for ordering performs ordering per each group. It orders the data collected through the generated query again, then configures the result.

The data collection for ordering is supported by the merge sort method. The merge sort method uses multiple clusters.

The following is an example of processing the ordering by using the preserved order in multiple clusters.

```
gSQL> \EXPLAIN PLAN SELECT c1 FROM t_shard_1 ORDER BY c1;
C1
--
 1
 2
 3
3 rows selected.
>>> start print plan
< Execution Plan >
=====
|  IDX  | NODE DESCRIPTION                                |          ROWS | |
|---|---|---|---|
|   0   | SELECT STATEMENT                                |              3 |
|   1   | QUERY BLOCK ("$_QB_IDX_2")                      |              3 |
|   2   | MULTIPLE CLUSTER                                | LOCAL/REMOTE 3 |
|   3   | SELECT STATEMENT                                |              1 |
|   4   | QUERY BLOCK ("$_QB_IDX_2")                      |              1 |
|   5   | INDEX ACCESS ("T_SHARD_1" AS _A1, "IDX") | (          1) | 1 |
=====
 1 - TARGET : T_SHARD_1.C1
 2 - SQL : SELECT /*+ INDEX( _A1, "PUBLIC"."IDX" ) */ "_A1"."C1" FROM
"PUBLIC"."T_SHARD_1"@LOCAL AS "_A1" ORDER BY "_A1"."C1" ASC NULLS LAST
      TARGET DOMAIN : G1(G1N1,G1N2) 1 rows, G2(G2N1,G2N2) 1 rows, G3(G3N1,G3N2) 1 rows
      MERGE SORTING
      SORT KEY : T_SHARD_1.C1
 4 - TARGET : _A1.C1
 5 - RANGE SHARD ( # 3 )
      READ INDEX COLUMN : _A1.C1
<<< end print plan
```

The following is an example of processing the ordering when the preserved order does not exist in multiple clusters.

```

gSQL> \EXPLAIN PLAN SELECT /*+ FULL( t_shard_1 ) */ c1 FROM t_shard_1 ORDER BY c1;
C1
--
 1
 2
 3
3 rows selected.
>>> start print plan
< Execution Plan >
=====
|  IDX  |  NODE DESCRIPTION                               |          ROWS |
-----|-----|-----|
|   0   |  SELECT STATEMENT                               |              3 |
|   1   |    QUERY BLOCK ("$_QB_IDX_2")                   |              3 |
|   2   |      MULTIPLE CLUSTER                           | LOCAL/REMOTE 3 |
|   3   |        SELECT STATEMENT                         |              1 |
|   4   |          QUERY BLOCK ("$_QB_IDX_2")              |              1 |
|   5   |            SORT INSTANT                          |              1 |
|   6   |              TABLE ACCESS ("T_SHARD_1" AS _A1) |              1 |
=====
 1 - TARGET : T_SHARD_1.C1
 2 - SQL : SELECT /*+ USE_ORDER_SORT FULL( _A1 ) */ "_A1"."C1" FROM
"PUBLIC"."T_SHARD_1"@LOCAL AS "_A1" ORDER BY "_A1"."C1" ASC NULLS LAST
      TARGET DOMAIN : G1(G1N1,G1N2) 1 rows, G2(G2N1,G2N2) 1 rows, G3(G3N1,G3N2) 1 rows
      MERGE SORTING
      SORT KEY : T_SHARD_1.C1
 4 - TARGET : _A1.C1
 5 - SORT KEY : "_A1.C1 ASC NULLS LAST"
      READ KEY COLUMN : _A1.C1
 6 - RANGE SHARD ( # 3 )
      READ COLUMN : _A1.C1
<<< end print plan

```

## Generated Query for Intersect Key Group

The intersect key group evaluation determines whether it received the same data from all groups.

It is not applied to all collected data. The intersect is applied only when key group values are same and all of nil expression values are null.

If nil expression value is not null, then the result is configured without evaluating the intersect key group.

If all nil expression values are null, then it configures the intersect key group result only when it received t

he same data from all groups.

The generated query for the intersect key group is ordered in an order of the key group. The data collected through the generated query is ordered again in an order of the key group. The intersect key group is applied to the sorted data according to the nil expression value.

The following is an example of processing the intersect key group in multiple clusters.

```
gSQL> \EXPLAIN PLAN
      SELECT /*+ REMOTE_JOIN( t_clone_1 ) */ t_clone_1.c1, t_shard_1.c1
      FROM t_clone_1
      LEFT OUTER JOIN
      t_shard_1
      ON t_clone_1.c1 = t_shard_1.c1;

C1  C1
--  ---
 1  1
 3  3
 5  null
3 rows selected.
>>> start print plan
< Execution Plan >

=====
|  IDX  | NODE DESCRIPTION                               |          ROWS |
=====
0	SELECT STATEMENT	3	
1	QUERY BLOCK (" $QB_IDX_2" )	3	
2	MULTIPLE CLUSTER	LOCAL/REMOTE 3	
3	SELECT STATEMENT	3	
4	QUERY BLOCK (" $QB_IDX_2" )	3	
5	SORT INSTANT	3	
6	NESTED JOIN (LEFT OUTER JOIN)	3	
7	TABLE ACCESS ("T_CLONE_1" AS _A2)	3	
8	INDEX ACCESS ("T_SHARD_1" AS _A1, "IDX")	( 1)	1
=====

 1 - TARGET : T_CLONE_1.C1, T_SHARD_1.C1
 2 - SQL : SELECT /*+ KEEP_JOINED_TABLE USE_NL_IN( _A1 ) FULL( _A2 ) INDEX( _A1,
"PUBLIC"."IDX" ) */ "_A2"."C1", "_A1"."C1" FROM (
"PUBLIC"."T_CLONE_1"@G1N1|G1N2|G2N1|G2N2|G3N1|G3N2" AS "_A2" LEFT OUTER JOIN
"PUBLIC"."T_SHARD_1"@G1N1|G1N2|G2N1|G2N2|G3N1|G3N2" AS "_A1" ON "_A1"."C1" =
"_A2"."C1") ALIAS "_A3" ORDER BY "_A2"."C1" ASC NULLS LAST
      TARGET DOMAIN : G1(G1N1,G1N2) 3 rows, G2(G2N1,G2N2) 3 rows, G3(G3N1,G3N2) 3 rows
```



**INTERSECT KEY GROUP**

```

KEY GROUP : T_CLONE_1.C1
Nil Expression : T_SHARD_1.C1
4 - TARGET : _A2.C1, _A1.C1
5 - SORT KEY : "_A2.C1 ASC NULLS LAST"
RECORD COLUMN : _A1.C1
READ KEY COLUMN : _A2.C1
READ RECORD COLUMN : _A1.C1
6 - JOINED COLUMN : _A2.C1, _A1.C1
7 - CLONED
READ COLUMN : _A2.C1
8 - RANGE SHARD ( # 3 )
READ INDEX COLUMN : _A1.C1
MIN RANGE : _A1.C1 = { _A2.C1 }
MAX RANGE : _A1.C1 = { _A2.C1 }

```

```
<<< end print plan
```

## Generated Query for Distinct Key Group

The distinct key group evaluation determines whether it received the same data from two or more groups.

Distinct is applied when the key group values are same and the data was received from each group. Distinct is not applied to the data from the same group.

The generated query for the distinct key group is ordered in an order of the key group. The data collected through the generated query is ordered again in an order of the key group. The distinct key group is applied to the sorted data according to the received group.

The following is an example of processing the distinct key group in multiple clusters.

```

gSQL> \EXPLAIN PLAN
      SELECT t_clone_1.c1
      FROM t_clone_1
      WHERE t_clone_1.c1 IN ( SELECT /*+ REMOTE_UNNEST */ t_shard_1.c1 FROM t_shard_1 );

```

```
C1
```

```
--
```

```
1
```

```
3
```

```
2 rows selected.
```

```
>>> start print plan
```

```
< Execution Plan >
```

```
=====
```

| ! IDX ! | NODE DESCRIPTION | ! ROWS ! |
|---------|------------------|----------|
|---------|------------------|----------|

```

-----
0	SELECT STATEMENT		2
1	QUERY BLOCK (" $QB_IDX_2" )		2
2	MULTIPLE CLUSTER	LOCAL/REMOTE	2
3	SELECT STATEMENT		1
4	QUERY BLOCK (" $QB_IDX_2" )		1
5	SORT INSTANT		1
6	HASH JOIN (SEMI)		1
7	TABLE ACCESS ("T_CLONE_1" AS _A2)		3
8	HASH JOIN INSTANT (UNIQUE)		1
9	INDEX ACCESS ("T_SHARD_1" AS _A1, "IDX")	( 1)	1
-----

```

```

=====
1 - TARGET : T_CLONE_1.C1
2 - SQL : SELECT /*+ KEEP_JOINED_TABLE USE_HASH_IN( _A1, 100 ) FULL( _A2 ) INDEX( _A1,
"PUBLIC"."IDX" ) */ "_A2"."C1" FROM (
"PUBLIC"."T_CLONE_1"@G1N1|G1N2|G2N1|G2N2|G3N1|G3N2" AS "_A2" SEMI JOIN
"PUBLIC"."T_SHARD_1"@G1N1|G1N2|G2N1|G2N2|G3N1|G3N2" AS "_A1" ON "_A1"."C1" =
"_A2"."C1") ALIAS "_A3" ORDER BY "_A2"."C1" ASC NULLS LAST
      TARGET DOMAIN : G1(G1N1,G1N2) 1 rows, G2(G2N1,G2N2) 0 rows, G3(G3N1,G3N2) 1 rows
      DISTINCT KEY GROUP
      KEY GROUP : T_CLONE_1.C1
4 - TARGET : _A2.C1
5 - SORT KEY : "_A2.C1 ASC NULLS LAST"
      READ KEY COLUMN : _A2.C1
6 - JOINED COLUMN : _A2.C1
7 - CLONED
      READ COLUMN : _A2.C1
8 - HASH KEY : _A1.C1
      READ KEY COLUMN : _A1.C1
      HASH FILTER : _A1.C1 = _A2.C1
      FETCH ONE ROW
9 - RANGE SHARD ( # 3 )
      READ INDEX COLUMN : _A1.C1
<<< end print plan

```

## Constraints of Generated Query Configuration

The generated query configuration is constrained in the following cases.

- Offset & limit
- Using non-deterministic expression

- When unable to unnest subquery

## Offset & limit



The information about **offset limit clause** is not included in a generated query.

- The generated query does not include the offset information.

```
gSQL> \EXPLAIN PLAN ONLY SELECT c1 FROM t_shard_1 OFFSET 1;
>>> start print plan
< Execution Plan >
=====
|  IDX  |  NODE DESCRIPTION          |          ROWS |
-----|-----|-----|
|   0   |  SELECT STATEMENT          |              0 |
|   1   |  QUERY BLOCK ("$_QB_IDX_2") |              0 |
|   2   |  PLAN BASED CLUSTER        |              0 |
|   3   |  INDEX ACCESS ("T_SHARD_1", "IDX") |              0 |
=====
1 - TARGET : T_SHARD_1.C1
2 - SQL : SELECT /*+ INDEX( _A1, "PUBLIC"."IDX" ) */ "_A1"."C1" FROM
"PUBLIC"."T_SHARD_1"@LOCAL AS "_A1"
      TARGET DOMAIN : G1(G1N1,G1N2) 0 rows, G2(G2N1,G2N2) 0 rows, G3(G3N1,G3N2) 0 rows
3 - RANGE SHARD ( # 3 )
      READ INDEX COLUMN : T_SHARD_1.C1
<<< end print plan
```

- The generated query does not include the limit information.

```
gSQL> \EXPLAIN PLAN ONLY SELECT c1 FROM t_shard_1 LIMIT 1;
>>> start print plan
< Execution Plan >
=====
|  IDX  |  NODE DESCRIPTION          |          ROWS |
-----|-----|-----|
|   0   |  SELECT STATEMENT          |              0 |
|   1   |  QUERY BLOCK ("$_QB_IDX_2") |              0 |
|   2   |  PLAN BASED CLUSTER        |              0 |
|   3   |  INDEX ACCESS ("T_SHARD_1", "IDX") |              0 |
=====
1 - TARGET : T_SHARD_1.C1
```

```

2 - SQL : SELECT /*+ INDEX( _A1, "PUBLIC"."IDX" ) */ "_A1"."C1" FROM
"PUBLIC"."T_SHARD_1"@LOCAL AS "_A1"
      TARGET DOMAIN : G1(G1N1,G1N2) 0 rows, G2(G2N1,G2N2) 0 rows, G3(G3N1,G3N2) 0 rows
3 - RANGE SHARD ( # 3 )
      READ INDEX COLUMN : T_SHARD_1.C1
<<< end print plan

```

## Using non-deterministic expression



When using the non-deterministic expression, if non-deterministic expression can not be made into a constant, then it is not included in the generated query.

- The generated query does not include a sequence related expression.

```

gSQL> \EXPLAIN PLAN ONLY SELECT seq.nextval FROM t_shard_1;
>>> start print plan
< Execution Plan >
=====
|  IDX  |  NODE DESCRIPTION          |          ROWS |
=====
|   0   |  SELECT STATEMENT          |              0 |
|   1   |  QUERY BLOCK ("QB_IDX_2")  |              0 |
|   2   |  PLAN BASED CLUSTER        |              0 |
|   3   |  INDEX ACCESS ("T_SHARD_1", "IDX") |              0 |
=====
1 - TARGET : NEXTVAL(SEQ)
2 - SQL : SELECT /*+ INDEX( _A1, "PUBLIC"."IDX" ) */ NULL FROM
"PUBLIC"."T_SHARD_1"@LOCAL AS "_A1"
      TARGET DOMAIN : G1(G1N1,G1N2) 0 rows, G2(G2N1,G2N2) 0 rows, G3(G3N1,G3N2) 0 rows
3 - RANGE SHARD ( # 3 )
      READ INDEX COLUMN : NOTHING
<<< end print plan

```

- The non-deterministic expression which can be made into a constant is made into a constant by the subordinate cluster puller node.
- The generated query includes the non-deterministic expression in a bind parameter form.

```

gSQL> \EXPLAIN PLAN ONLY SELECT c1 FROM t_shard_1 WHERE shard_key = random( 1, 100 );
>>> start print plan
< Execution Plan >
=====

```

```

IDX	NODE DESCRIPTION	ROWS
0	SELECT STATEMENT	
1	QUERY BLOCK ("$_QB_IDX_2")	
2	PLAN BASED CLUSTER	
3	TABLE ACCESS ("T_SHARD_1")	
=====
1 - TARGET : T_SHARD_1.C1
2 - SQL : SELECT /*+ FULL( _A1 ) */ "_A1"."C1" FROM "PUBLIC"."T_SHARD_1"@LOCAL AS "_A1"
WHERE "_A1"."SHARD_KEY" = :_V0
      TARGET DOMAIN : G1(G1N1,G1N2) 0 rows, G2(G2N1,G2N2) 0 rows, G3(G3N1,G3N2) 0 rows
3 - RANGE SHARD ( # 3 )
      READ COLUMN : T_SHARD_1.SHARD_KEY, T_SHARD_1.C1
      PHYSICAL FILTER : T_SHARD_1.SHARD_KEY = RANDOM(1,100)
<<< end print plan

```

- The non-deterministic expression which can not be made into a constant is not included in the generated query.
- The non-deterministic expression is processed after the data is collected on the cluster puller node.

```

gSQL> \EXPLAIN PLAN ONLY
SELECT 1 FROM t_shard_1 WHERE shard_key = random( c1, 100 );
>>> start print plan
< Execution Plan >
=====
====
|  IDX  |  NODE DESCRIPTION  |  ROWS  |
-----|-----|-----|
|   0   |  SELECT STATEMENT  |         |
|   1   |  FILTER            |         |
0 |
|   2   |  CLUSTER ACCESS ("T_SHARD_1") [RANGE SHARDING] |         |
0 |
|   3   |  TABLE ACCESS ("T_SHARD_1") [RANGE SHARDING] |         |
0 |
=====
====
1 - READ COLUMNS : NOTHING

```

```

        FILTER : T_SHARD_1.SHARD_KEY = RANDOM(T_SHARD_1.C1,100)
    2 - SQL : SELECT /*+ FULL("_A1") */ "_A1"."SHARD_KEY", "_A1"."C1" FROM
"PUBLIC"."T_SHARD_1"@LOCAL "_A1"
    3 - READ COLUMNS : SHARD_KEY, C1
<<< end print plan

```

## When unable to unnest subquery



A subquery which can be made into a constant is included in the generated query in a bind parameter form.

A subquery which can not be made into a constant is not included in the generated query.

For more information about unnesting a subquery, refer to [Subquery](#).

- The generated query can not include the unnested subquery.
- The subquery is processed on the cluster puller node or the superordinate node.

```

gSQL> \EXPLAIN PLAN
      SELECT shard_key
      FROM t_shard_1
      WHERE t_shard_1.c1 IN ( SELECT /*+ NO_QUERY_TRANSFORMATION */ t_clone_1.c1 FROM
t_clone_1 );

```

```
SHARD_KEY
```

```

-----
      111
      555

```

2 rows selected.

```
>>> start print plan
```

```
< Execution Plan >
```

```

=====
IDX	NODE DESCRIPTION	ROWS
0	SELECT STATEMENT	2
1	QUERY BLOCK ("QB_IDX_2")	2
2	PLAN BASED CLUSTER	LOCAL/REMOTE 2
3	TABLE ACCESS ("T_SHARD_1")	1
4	SUB QUERY LIST	
5	INLINE_VIEW ("V5") (MATERIALIZED)	2
6	QUERY BLOCK ("QB_IDX_6")	3
7	TABLE ACCESS ("T_CLONE_1")	3
=====

```

```

1 - TARGET : T_SHARD_1.SHARD_KEY
2 - SQL : SELECT /*+ FULL( _A1 ) */ "_A1"."SHARD_KEY", "_A1"."C1" FROM
"PUBLIC"."T_SHARD_1"@LOCAL AS "_A1"
      TARGET DOMAIN : G1(G1N1,G1N2) 1 rows, G2(G2N1,G2N2) 1 rows, G3(G3N1,G3N2) 1 rows
      POST FILTER : ( T_SHARD_1.C1 ) IN ( $V5.C1 )
3 - RANGE SHARD ( # 3 )
      READ COLUMN : T_SHARD_1.SHARD_KEY, T_SHARD_1.C1
5 - COLUMN : T_CLONE_1.C1 AS C1
6 - TARGET : T_CLONE_1.C1
7 - CLONED
      READ COLUMN : T_CLONE_1.C1
<<< end print plan

```

- The generated query can not include a subquery which can not be made into a constant.

```

gSQL> \EXPLAIN PLAN
      SELECT shard_key
      FROM t_shard_1
      WHERE shard_key = ( SELECT c1 FROM dual );
no rows selected.
>>> start print plan
< Execution Plan >
=====
|  IDX  |  NODE DESCRIPTION          |  ROWS  |
-----|-----|-----|
|   0   |  SELECT STATEMENT          |        |
|   1   |  QUERY BLOCK ("QB_IDX_2")  |        |
|   2   |  PLAN BASED CLUSTER        | LOCAL/REMOTE |
|   3   |  TABLE ACCESS ("T_SHARD_1") |        |
|   4   |  SUB QUERY LIST            |        |
|   5   |  INLINE_VIEW ("V5")      |        |
|   6   |  QUERY BLOCK ("QB_IDX_6")  |        |
|   7   |  FAST DUAL ACCESS ("DUAL") |        |
=====
1 - TARGET : T_SHARD_1.SHARD_KEY
2 - SQL : SELECT /*+ FULL( _A1 ) */ "_A1"."SHARD_KEY", "_A1"."C1" FROM
"PUBLIC"."T_SHARD_1"@LOCAL AS "_A1"
      TARGET DOMAIN : G1(G1N1,G1N2) 1 rows, G2(G2N1,G2N2) 1 rows, G3(G3N1,G3N2) 1 rows
      POST FILTER : T_SHARD_1.SHARD_KEY = $V5.C1
3 - RANGE SHARD ( # 3 )
      READ COLUMN : T_SHARD_1.SHARD_KEY, T_SHARD_1.C1

```

```

5 - COLUMN : {T_SHARD_1.C1} AS C1
6 - TARGET : {T_SHARD_1.C1}
7 - READ COLUMN : NOTHING

```

```
<<< end print plan
```

- The generated query includes a subquery which can be made into a constant in a bind parameter for m.

```
gSQL> \EXPLAIN PLAN
```

```

SELECT shard_key
  FROM t_shard_1
 WHERE shard_key = ( SELECT 111 FROM dual );

```

```
SHARD_KEY
```

```

-----
      111

```

```
1 row selected.
```

```
>>> start print plan
```

```
< Execution Plan >
```

```

=====
IDX	NODE DESCRIPTION	ROWS
0	SELECT STATEMENT	
1	QUERY BLOCK ("QB_IDX_2")	
2	PLAN BASED CLUSTER	LOCAL ONLY
3	TABLE ACCESS ("T_SHARD_1")	
4	SUB QUERY LIST	
5	INLINE_VIEW ("V5")	
6	QUERY BLOCK ("QB_IDX_6")	
7	FAST DUAL ACCESS ("DUAL")	
=====

```

```
1 - TARGET : T_SHARD_1.SHARD_KEY
```

```
2 - SQL : SELECT /*+ FULL( _A1 ) */ "_A1"."SHARD_KEY" FROM "PUBLIC"."T_SHARD_1"@LOCAL
AS "_A1" WHERE "_A1"."SHARD_KEY" = :_V0
```

```
TARGET DOMAIN : G1(G1N1,G1N2) 1 rows, G2(G2N1,G2N2) 0 rows, G3(G3N1,G3N2) 0 rows
```

```
SHARD KEY FILTER : ( T_SHARD_1.SHARD_KEY = $V5.$C0 )
```

```
3 - RANGE SHARD ( # 3 )
```

```
READ COLUMN : T_SHARD_1.SHARD_KEY
```

```
PHYSICAL FILTER : T_SHARD_1.SHARD_KEY = $V5.$C0
```

```
5 - COLUMN : 111 AS $C0
```

```
6 - TARGET : 111
```

```
7 - READ COLUMN : NOTHING
```



◀◀ end print plan

## Cluster Pusher

The cluster pusher node creates and manages a virtual table for the efficient query process of the cluster puller node.

Figure 7 Cluster puller vs cluster pusher

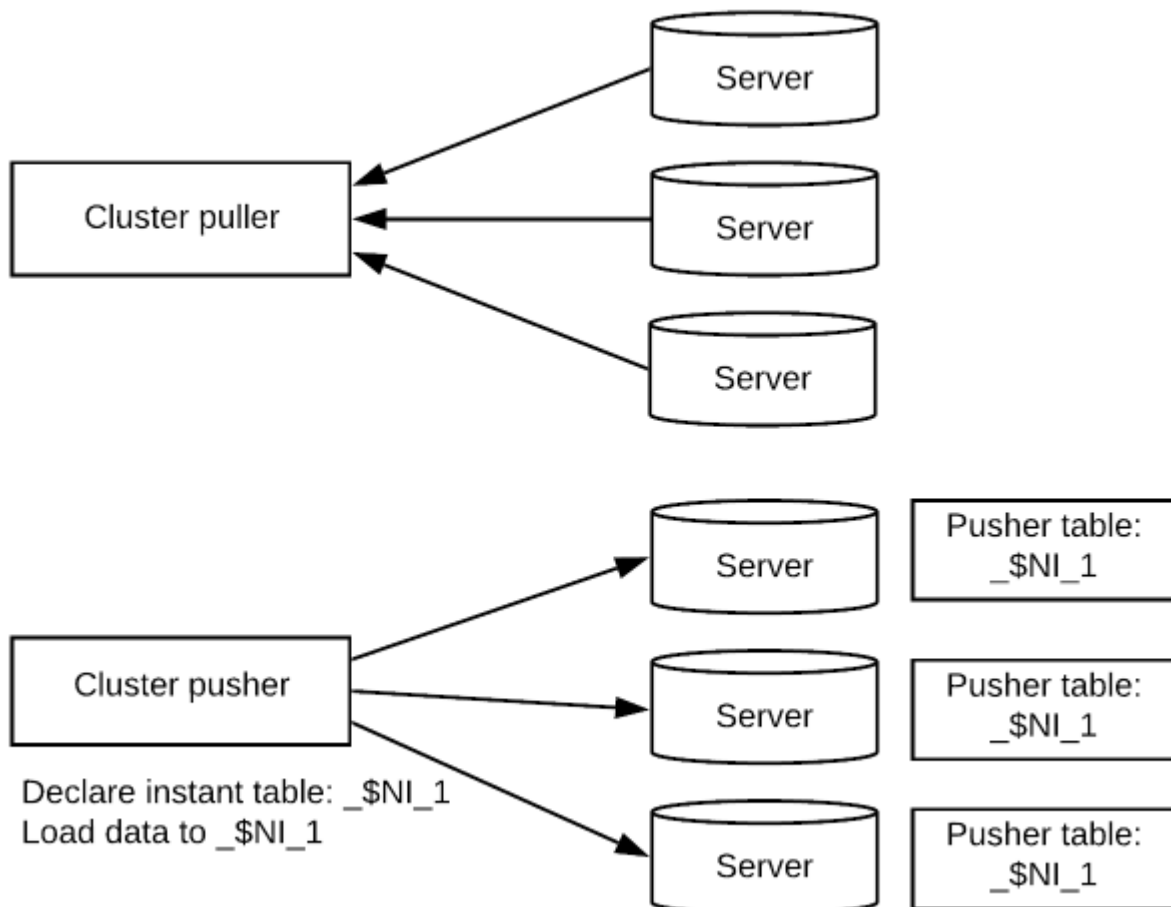

The cluster puller node collects the data. The cluster pusher node distributes the data in a new table form.

The cluster pusher node declares a pusher table and loads the data.

- Declaring pusher table: It creates an instant table in a local server and a remote server.
- Loading data: It loads the data received from the subordinate node of the cluster pusher node on the pusher table.

Figure 8 Performing cluster pusher

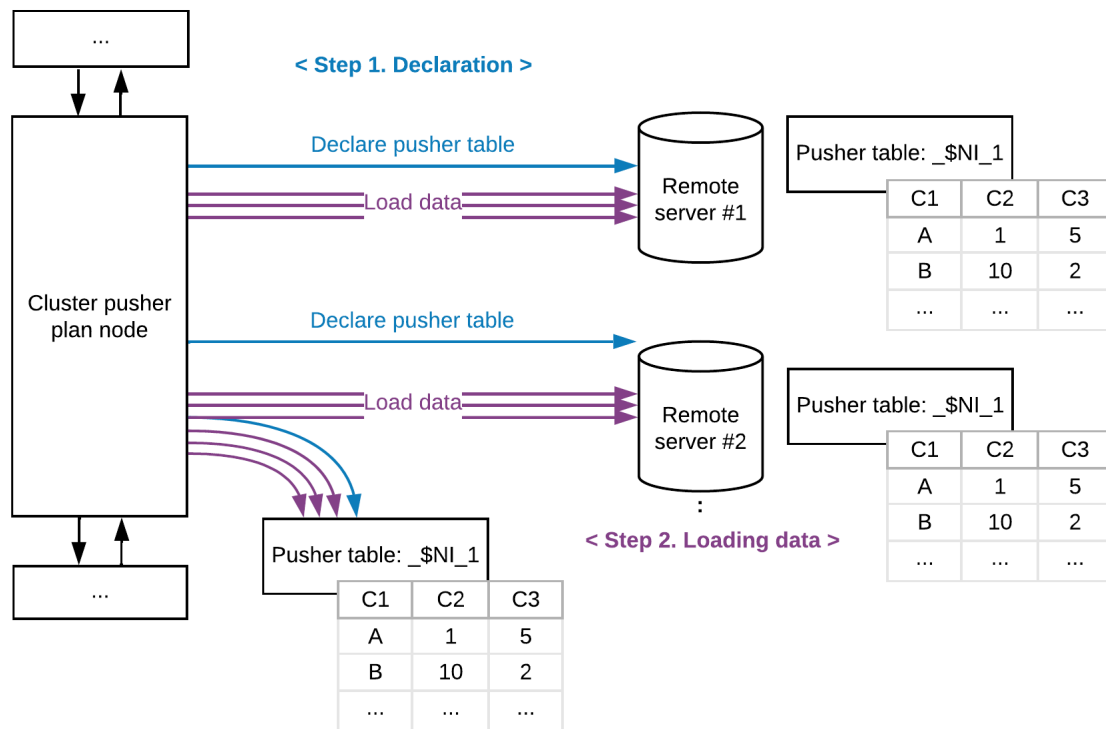

The following is an example of using the cluster pusher.

```

gSQL> \EXPLAIN PLAN ONLY
      SELECT A.c1
      FROM t_shard_1 AS A, t_shard_1 AS B
      WHERE A.shard_key = B.c1;
>>> start print plan
< Execution Plan >
=====
|  IDX  |  NODE DESCRIPTION  |  ROWS  |
=====
|  0  |  SELECT STATEMENT  |        |
|  1  |  QUERY BLOCK ("QB_IDX_2") |        |
|  2  |  SINGLE CLUSTER    |        |
|  3  |  CLUSTER PUSHER ("$_NI_7") |        |
|  4  |  PLAN BASED CLUSTER |        |
|  5  |  INDEX ACCESS ("T_SHARD_1" AS B, "IDX") |        |
|  6  |  HASH JOIN (INNER JOIN) |        |
|  7  |  TABLE ACCESS ("T_SHARD_1" AS A) |        |
|  8  |  HASH JOIN INSTANT |        |
|  9  |  PUSHER TABLE ACCESS ("$_NI_7") |        |
=====
1 - TARGET : A.C1
    
```

```

2 - SQL : SELECT /*+ KEEP_JOINED_TABLE USE_HASH_IN( _A1, 100 ) FULL( _A2 ) FULL( _A1 )
*/ "_A2"."C1" FROM ( "PUBLIC"."T_SHARD_1"@LOCAL AS "_A2" INNER JOIN
"SESSION_SCHEMA"."_$NI_7"@LOCAL AS "_A1" ON "_A1"."C1" = "_A2"."SHARD_KEY") ALIAS "_A3"
      TARGET DOMAIN : G1(G1N1,G1N2) 0 rows, G2(G2N1,G2N2) 0 rows, G3(G3N1,G3N2) 0 rows
3 - SQL : DECLARE INSTANT TABLE "SESSION_SCHEMA"."_$NI_7" ( "C1" NUMBER(10, 0) )
      COLUMN : B.C1 AS C1
      SHARDED : B.C1
      TARGET DOMAIN : G1(G1N1,G1N2) 0 rows, G2(G2N1,G2N2) 0 rows, G3(G3N1,G3N2) 0 rows
4 - SQL : SELECT /*+ INDEX( _A1, "PUBLIC"."IDX" ) */ "_A1"."C1" FROM
"PUBLIC"."T_SHARD_1"@LOCAL AS "_A1"
      TARGET DOMAIN : G1(G1N1,G1N2) 0 rows, G2(G2N1,G2N2) 0 rows, G3(G3N1,G3N2) 0 rows
5 - RANGE SHARD ( # 3 )
      READ INDEX COLUMN : B.C1
6 - JOINED COLUMN : A.C1
7 - RANGE SHARD ( # 3 )
      READ COLUMN : A.SHARD_KEY, A.C1
8 - HASH KEY : _$NI_7.C1
      READ KEY COLUMN : _$NI_7.C1
      HASH FILTER : _$NI_7.C1 = A.SHARD_KEY
<<< end print plan

```

In the execution plan above, the plan whose idx of <Execution Plan> is 3 is the cluster pusher.

The pusher table name is output on NODE DESCRIPTION of the cluster pusher.

The detailed information about CLUSTER PUSHER is as follows.

- SQL: It is a query declaring a pusher table.
- COLUMN: It is an original expression per each column of the pusher table.
- SHARDED: They are columns of a pusher table used based on the pusher table data distribution.
- TARGET DOMAIN: It is the member and group to configure the pusher table, and the number of data transferred that group.

## Pusher Table

The pusher table is an instant table in user query unit which is configured by the query processor to efficiently use the cluster puller. It is used to build the collected data in the driver server in a relation form.

The configured pusher table can be referred from the generated query like as a general table.

The following is an example of performing the join query which does not use the pusher table.

```

gSQL> \EXPLAIN PLAN
      SELECT /*+ LOCAL_JOIN( t_shard_1 ) */ t_shard_1.c1

```

```

        FROM t_shard_1, t_shard_2
        WHERE t_shard_1.shard_key = t_shard_2.shard_key;
C1
--
1
3
2
3 rows selected.
>>> start print plan
< Execution Plan >
=====
|  IDX  |  NODE DESCRIPTION  |  ROWS  |
=====
|   0   |  SELECT STATEMENT  |        |
|   1   |  QUERY BLOCK ("SQB_IDX_2") |        |
|   2   |  HASH JOIN (INNER JOIN) |        |
|   3   |  PLAN BASED CLUSTER | LOCAL/REMOTE |
|   4   |  TABLE ACCESS ("T_SHARD_1") |        |
|   5   |  HASH JOIN INSTANT |        |
|   6   |  PLAN BASED CLUSTER | LOCAL/REMOTE |
|   7   |  TABLE ACCESS ("T_SHARD_2") |        |
=====
1 - TARGET : T_SHARD_1.C1
2 - JOINED COLUMN : T_SHARD_1.C1
3 - SQL : SELECT /*+ FULL( _A1 ) */ "_A1"."SHARD_KEY", "_A1"."C1" FROM
"PUBLIC"."T_SHARD_1"@LOCAL AS "_A1"
      TARGET DOMAIN : G1(G1N1,G1N2) 1 rows, G2(G2N1,G2N2) 1 rows, G3(G3N1,G3N2) 1 rows
4 - RANGE SHARD ( # 3 )
      READ COLUMN : T_SHARD_1.SHARD_KEY, T_SHARD_1.C1
5 - HASH KEY : T_SHARD_2.SHARD_KEY
      READ KEY COLUMN : T_SHARD_2.SHARD_KEY
      HASH FILTER : T_SHARD_2.SHARD_KEY = T_SHARD_1.SHARD_KEY
6 - SQL : SELECT /*+ FULL( _A1 ) */ "_A1"."SHARD_KEY" FROM "PUBLIC"."T_SHARD_2"@LOCAL
AS "_A1"
      TARGET DOMAIN : G1(G1N1,G1N2) 1 rows, G3(G3N1,G3N2) 2 rows
7 - RANGE SHARD ( # 4 )
      READ COLUMN : T_SHARD_2.SHARD_KEY
<<< end print plan

```

Two cluster puller plans are used when performing the join as given above. It is because a single generated query can not process the join for two tables with each different sharding strategy.

The following is an example of performing the join query by using the pusher table.

```

gSQL> \EXPLAIN PLAN
SELECT /*+ REMOTE_JOIN( t_shard_1 ) */ t_shard_1.c1
  FROM t_shard_1, t_shard_2
 WHERE t_shard_1.shard_key = t_shard_2.shard_key;
C1
--
 1
 2
 3
3 rows selected.
>>> start print plan
< Execution Plan >
=====
|  IDX  | NODE DESCRIPTION                               |          ROWS |
=====
|   0   | SELECT STATEMENT                               |              3 |
|   1   | QUERY BLOCK ("$_QB_IDX_2")                    |              3 |
|   2   | SINGLE CLUSTER                               | LOCAL/REMOTE 3 |
|   3   | CLUSTER PUSHER ("$_NI_7")                  |              3 |
|   4   | PLAN BASED CLUSTER                            | LOCAL/REMOTE 3 |
|   5   | TABLE ACCESS ("T_SHARD_2")                  |              1 |
|   6   | SELECT STATEMENT                               |              1 |
|   7   | QUERY BLOCK ("$_QB_IDX_2")                    |              1 |
|   8   | HASH JOIN (INNER JOIN)                       |              1 |
|   9   | TABLE ACCESS ("T_SHARD_1" AS _A2)           |              1 |
|  10   | HASH JOIN INSTANT                             |              1 |
|  11   | PUSHER TABLE ACCESS ("$_NI_7" AS _A1)       |              1 |
=====
 1 - TARGET : T_SHARD_1.C1
 2 - SQL : SELECT /*+ KEEP_JOINED_TABLE USE_HASH_IN( _A1, 10 ) FULL( _A2 ) FULL( _A1 )
*/ "_A2"."C1" FROM ( "PUBLIC"."T_SHARD_1"@LOCAL AS "_A2" INNER JOIN
"SESSION_SCHEMA"."$_NI_7"@LOCAL AS "_A1" ON "_A1"."SHARD_KEY" = "_A2"."SHARD_KEY") ALIAS "_A3"
  TARGET DOMAIN : G1(G1N1,G1N2) 1 rows, G2(G2N1,G2N2) 1 rows, G3(G3N1,G3N2) 1 rows
 3 - SQL : DECLARE INSTANT TABLE "SESSION_SCHEMA"."$_NI_7" ( "SHARD_KEY" NUMBER(10, 0) )
  COLUMN : T_SHARD_2.SHARD_KEY AS SHARD_KEY
  SHARDED : T_SHARD_2.SHARD_KEY
  TARGET DOMAIN : G1(G1N1,G1N2) 1 rows, G2(G2N1,G2N2) 1 rows, G3(G3N1,G3N2) 1 rows
 4 - SQL : SELECT /*+ FULL( _A1 ) */ "_A1"."SHARD_KEY" FROM "PUBLIC"."T_SHARD_2"@LOCAL
AS "_A1"

```

```

        TARGET DOMAIN : G1(G1N1,G1N2) 1 rows, G3(G3N1,G3N2) 2 rows
5  - RANGE SHARD ( # 4 )
    READ COLUMN : T_SHARD_2.SHARD_KEY
7  - TARGET : _A2.C1
8  - JOINED COLUMN : _A2.C1
9  - RANGE SHARD ( # 3 )
    READ COLUMN : _A2.SHARD_KEY, _A2.C1
10 - HASH KEY : _A1.SHARD_KEY
    READ KEY COLUMN : _A1.SHARD_KEY
    HASH FILTER : _A1.SHARD_KEY = _A2.SHARD_KEY
11 - READ COLUMN : _A1.SHARD_KEY
<<< end print plan

```

The generated query of the cluster puller configured in the execution result above includes the join.

CLUSTER PUSHER which is configured under SINGLE CLUSTER defines the pusher table "\$NI\_7" through DECLARE statement.

The data collected from table t\_shard\_2 in CLUSTER PUSHER are distributed to the pusher table in a local server and a remote server by using the sharding strategy of t\_shard\_1. The join for those two tables can be processed by expressing them as a single generated query, because t\_shard\_1 and pusher table use the same sharding strategy.

The pusher table has following features.

- It declares the pusher table on the cluster pusher plan node, and loads the data.
- It is configured as a table included in SESSION\_SCHEMA.
- It can not configure an index.
- Multiple pusher tables can be configured in a single user query.
- Pusher tables are not shared among user queries.
- The performance cycle of the user query and the management cycle of the pusher table are same.
- The pusher table configured in each server has either a replicated data or a distributed data.

## Pusher Table Configured with Replicated Data

The data configuration of the pusher table varies upon performing the cluster puller.

The pusher table configured to process the outer join as given below processes the generated query including the outer join with all servers having the same data for t\_shard\_2.

```

gSQL> \EXPLAIN PLAN ONLY
    SELECT A.c1
        FROM t_shard_1 AS A LEFT OUTER JOIN t_shard_2 AS B ON A.c1 = B.c1;
>>> start print plan

```

## &lt; Execution Plan &gt;

```

=====
|  IDX  |  NODE DESCRIPTION                               |  ROWS  |
=====
0	SELECT STATEMENT	0
1	QUERY BLOCK ("$_QB_IDX_2")	0
2	SINGLE CLUSTER	0
3	CLUSTER PUSHER ("$_NI_5")	0
4	PLAN BASED CLUSTER	0
5	TABLE ACCESS ("T_SHARD_2" AS B)	0
6	HASH JOIN (INVERTED LEFT OUTER JOIN)	0
7	PUSHER TABLE ACCESS ("$_NI_5")	0
8	HASH JOIN INSTANT	0
9	INDEX ACCESS ("T_SHARD_1" AS A, "IDX")	0
=====

1 - TARGET : A.C1
2 - SQL : SELECT /*+ KEEP_JOINED_TABLE USE_HASH_IN( _A1, 100 ) FULL( _A2 ) INDEX( _A1,
"PUBLIC"."IDX" ) */ "_A1"."C1" FROM (
"PUBLIC"."T_SHARD_1"@G1N1"|G1N2"|G2N1"|G2N2"|G3N1"|G3N2" AS "_A1" LEFT OUTER JOIN
"SESSION_SCHEMA"."$_NI_5"@LOCAL AS "_A2" ON "_A1"."C1" = "_A2"."C1") ALIAS "_A3"
TARGET DOMAIN : G1(G1N1,G1N2) 0 rows, G2(G2N1,G2N2) 0 rows, G3(G3N1,G3N2) 0 rows
3 - SQL : DECLARE INSTANT TABLE "SESSION_SCHEMA"."$_NI_5" ( "C1" NUMBER(10, 0) )
COLUMN : B.C1 AS C1
CLONED
TARGET DOMAIN : G1(G1N1,G1N2) 0 rows, G2(G2N1,G2N2) 0 rows, G3(G3N1,G3N2) 0 rows
4 - SQL : SELECT /*+ FULL( _A1 ) */ "_A1"."C1" FROM "PUBLIC"."T_SHARD_2"@LOCAL AS "_A1"
TARGET DOMAIN : G1(G1N1,G1N2) 0 rows, G3(G3N1,G3N2) 0 rows
5 - RANGE SHARD ( # 4 )
READ COLUMN : B.C1
6 - JOINED COLUMN : A.C1
8 - HASH KEY : A.C1
READ KEY COLUMN : A.C1
HASH FILTER : A.C1 = $_NI_5.C1
9 - RANGE SHARD ( # 3 )
READ INDEX COLUMN : A.C1
<<< end print plan

```

The pusher table configured with the replicated data is output as CLONED as the result above.

## Pusher Table Configured with Distributed Data

The following is an example of processing outer join by using the sharding key of t\_shard\_1 as the join condition.

```
gSQL> \EXPLAIN PLAN ONLY
```

```
    SELECT A.c1
```

```
    FROM t_shard_1 AS A LEFT OUTER JOIN t_shard_2 AS B ON A.shard_key = B.c1;
```

```
>>> start print plan
```

```
< Execution Plan >
```

```
=====
```

| IDX | NODE DESCRIPTION                | ROWS |
|-----|---------------------------------|------|
| 0   | SELECT STATEMENT                | 0    |
| 1   | QUERY BLOCK ("\$_QB_IDX_2")     | 0    |
| 2   | SINGLE CLUSTER                  | 0    |
| 3   | CLUSTER PUSHER ("\$_NI_7")      | 0    |
| 4   | PLAN BASED CLUSTER              | 0    |
| 5   | TABLE ACCESS ("T_SHARD_2" AS B) | 0    |
| 6   | HASH JOIN (LEFT OUTER JOIN)     | 0    |
| 7   | TABLE ACCESS ("T_SHARD_1" AS A) | 0    |
| 8   | HASH JOIN INSTANT               | 0    |
| 9   | PUSHER TABLE ACCESS ("\$_NI_7") | 0    |

```
=====
```

- 1 - TARGET : A.C1
- 2 - SQL : SELECT /\*+ KEEP\_JOINED\_TABLE USE\_HASH\_IN( \_A1, 10 ) FULL( \_A2 ) FULL( \_A1 )
 \*/ "\_A2"."C1" FROM ( "PUBLIC"."T\_SHARD\_1"@G1N1|"G1N2"|"G2N1"|"G2N2"|"G3N1"|"G3N2" AS "\_A2"
 LEFT OUTER JOIN "SESSION\_SCHEMA"."\$\_NI\_7"@LOCAL AS "\_A1" ON "\_A1"."C1" = "\_A2"."SHARD\_KEY")
 ALIAS "\_A3"
 TARGET DOMAIN : G1(G1N1,G1N2) 0 rows, G2(G2N1,G2N2) 0 rows, G3(G3N1,G3N2) 0 rows
- 3 - SQL : DECLARE INSTANT TABLE "SESSION\_SCHEMA"."\$\_NI\_7" ( "C1" NUMBER(10, 0) )
 COLUMN : B.C1 AS C1
 **SHARDED : B.C1**
 TARGET DOMAIN : G1(G1N1,G1N2) 0 rows, G2(G2N1,G2N2) 0 rows, G3(G3N1,G3N2) 0 rows
- 4 - SQL : SELECT /\*+ FULL( \_A1 ) \*/ "\_A1"."C1" FROM "PUBLIC"."T\_SHARD\_2"@LOCAL AS "\_A1"
 TARGET DOMAIN : G1(G1N1,G1N2) 0 rows, G3(G3N1,G3N2) 0 rows
- 5 - RANGE SHARD ( # 4 )
 READ COLUMN : B.C1
- 6 - JOINED COLUMN : A.C1
- 7 - RANGE SHARD ( # 3 )
 READ COLUMN : A.SHARD\_KEY, A.C1
- 8 - HASH KEY : \$\_NI\_7.C1



```

READ KEY COLUMN : _$NI_7.C1
HASH FILTER : _$NI_7.C1 = A.SHARD_KEY

```

```
<<< end print plan
```

The pusher table divides the data for `t_shard_2` per a group. The data is distributed based on `C1` column of `t_shard_2` according to the sharding strategy configured in the sharding key of `t_shard_1`.

The pusher table which consists of the distributed data is output `SHARDED` as the detailed result above.

## Processing Cluster Query per SELECT Statement

The chapters above describe the **Cluster Puller** and **Cluster Pusher** plan node to process `SELECT` in cluster. This chapter describes how to process cluster query per `SELECT` statement by using them.

### FROM Statement (Single Table)

Processing a query in a single table is divided into the processing in a sharded table and the processing in a cloned table. If it is processed in a sharded table, then it is divided into `n` groups and stored, so it requests the query to both a local server and a remote server, then collects them and makes them into a result. `GOLDILOCKS` uses the plan based cluster or the single cluster plan node to request the query to the remote server and receive the result from it. Those cluster pullers simultaneously requests the query to both a local server and a remote server, then collect the results in parallel to make them into a result set.

The following is an example of processing the query in `part` table which is a sharded table.

```

gSQL> \EXPLAIN PLAN
      SELECT p_name, p_brand, p_type, cluster_group_id
      FROM part;
P_NAME P_BRAND  P_TYPE CLUSTER_GROUP_ID
-----
Part#3 Brand#2  STEEL          1
Part#2 Brand#1  NICKEL         2
Part#5 Brand#3  STEEL          2
Part#1 Brand#1  COPPER         3
Part#4 Brand#3  NICKEL         3
5 rows selected.
>>> start print plan
< Execution Plan >
=====
|  IDX  |  NODE DESCRIPTION          |  ROWS  |
-----
|   0   |  SELECT STATEMENT          |    5   |
|   1   |  QUERY BLOCK ("QB_IDX_2")  |    5   |

```

```

| 2 | PLAN BASED CLUSTER | LOCAL/REMOTE | 5 |
| 3 | TABLE ACCESS ("PART") | | 1 |
=====
1 - TARGET : PART.P_NAME, PART.P_BRAND, PART.P_TYPE, PART.CLUSTER_GROUP_ID
2 - SQL : SELECT /*+ FULL( _A1 ) */ "_A1"."CLUSTER_GROUP_ID", "_A1"."P_NAME",
"_A1"."P_BRAND", "_A1"."P_TYPE" FROM "PUBLIC"."PART"@LOCAL AS "_A1"
TARGET DOMAIN : G1(G1N1,G1N2) 1 rows, G2(G2N1,G2N2) 2 rows, G3(G3N1,G3N2) 2 rows
3 - HASH SHARD ( # 3 )
READ COLUMN : PART.P_NAME, PART.P_BRAND, PART.P_TYPE
<<< end print plan

```

When the cloned table is created by using the cloned strategy as AT CLUSTER WIDE strategy, then all nodes have replications, so most of local servers can process the query about the cloned table. However, if a new group or a new member is added, then the group or the member does not have data about the cloned table. Therefore, it should bring the data from the remote server, so it configures the cluster puller at that moment. For more information about the cloned strategy, refer to **Cloned Strategy**.

The following is an example of processing the query in *supplier* table which is a cloned table.

```

gSQL> \EXPLAIN PLAN
      SELECT s_name, s_nationkey
      FROM supplier;
S_NAME          S_NATIONKEY
-----
Supplier#1      FRANCE
Supplier#2      KOREA
Supplier#3      GERMANY
Supplier#4      UNITED STATES
Supplier#5      CANADA
5 rows selected.
>>> start print plan
< Execution Plan >
=====
|  IDX  |  NODE DESCRIPTION  |  ROWS  |
=====
|  0  |  SELECT STATEMENT  |  5  |
|  1  |  QUERY BLOCK ("SQB_IDX_2")  |  5  |
|  2  |  TABLE ACCESS ("SUPPLIER")  |  5  |
=====
1 - TARGET : SUPPLIER.S_NAME, SUPPLIER.S_NATIONKEY
2 - CLONED
READ COLUMN : SUPPLIER.S_NAME, SUPPLIER.S_NATIONKEY

```

```
<<< end print plan
```

It can bring all data about *supplier* table from a local server as given above, so it does not configure the cluster puller.

The following is an example of processing the query in *supplier* table which is a cloned table by using the domain.

```
gSQL> \EXPLAIN PLAN
      SELECT s_name, s_nationkey
      FROM supplier@G2;
S_NAME          S_NATIONKEY
-----
Supplier#1      FRANCE
Supplier#2      KOREA
Supplier#3      GERMANY
Supplier#4      UNITED STATES
Supplier#5      CANADA
5 rows selected.
>>> start print plan
< Execution Plan >
=====
|  IDX  |  NODE DESCRIPTION                               |          ROWS |
-----
0	SELECT STATEMENT	5
1	QUERY BLOCK ("$_QB_IDX_2")	5
2	PLAN BASED CLUSTER	REMOTE ONLY   5
3	TABLE ACCESS ("SUPPLIER")	0
=====
1 - TARGET : SUPPLIER.S_NAME, SUPPLIER.S_NATIONKEY
2 - SQL : SELECT /*+ FULL( _A1 ) */ "_A1"."S_NAME", "_A1"."S_NATIONKEY" FROM
"PUBLIC"."SUPPLIER"@LOCAL AS "_A1"
      TARGET DOMAIN : G2(G2N1,G2N2) 5 rows
3 - CLONED
      READ COLUMN : SUPPLIER.S_NAME, SUPPLIER.S_NATIONKEY
<<< end print plan
```

It configures the cluster puller as given above to bring the data about *supplier* table from the remote server.

## FROM Statement (Join)

The data collection for the cluster puller plan node are processed in one of the two following forms.

- Data collection from a single group: It is used for a query which consists of cloned tables only or when the cluster domain is limited to a single group.
- Data collection from multiple groups: It is used for a query which includes a sharded table.

Join using the cluster puller plan node are also performed in the two forms above.

When performing join by collecting data from a single group, then the join between two cloned tables configures cluster puller by collecting the data.

If the common cluster domain does not exist between two cloned tables, then one of the two following methods can be selected to perform it.

First, it configures the cluster puller per each join target table, then performs the join.

```
gSQL> \EXPLAIN PLAN
      SELECT s_suppkey, n_name
      FROM supplier@g2, nation@g3
      WHERE s_nationkey = n_nationkey;
S_SUPPKEY N_NAME
-----
1 FRANCE
2 INDIA
3 GERMANY
4 CANADA
5 UNITED STATES
5 rows selected.
>>> start print plan
< Execution Plan >
```

| IDX | NODE DESCRIPTION                      | ROWS |
|-----|---------------------------------------|------|
| 0   | SELECT STATEMENT                      | 5    |
| 1   | QUERY BLOCK ("SQB_IDX_2")             | 5    |
| 2   | <b>HASH JOIN (INNER JOIN)</b>         | 5    |
| 3   | <b>PLAN BASED CLUSTER</b> REMOTE ONLY | 5    |
| 4   | TABLE ACCESS ("SUPPLIER")             | 0    |
| 5   | HASH JOIN INSTANT                     | 5    |
| 6   | <b>PLAN BASED CLUSTER</b> REMOTE ONLY | 30   |
| 7   | TABLE ACCESS ("NATION")               | 0    |

```

1 - TARGET : SUPPLIER.S_SUPPKEY, NATION.N_NAME
2 - JOINED COLUMN : SUPPLIER.S_SUPPKEY, NATION.N_NAME
3 - SQL : SELECT /*+ FULL( _A1 ) */ "_A1"."S_SUPPKEY", "_A1"."S_NATIONKEY" FROM
"PUBLIC"."SUPPLIER"@LOCAL AS "_A1"
      TARGET DOMAIN : G2(G2N1,G2N2) 5 rows
4 - CLONED
      READ COLUMN : SUPPLIER.S_SUPPKEY, SUPPLIER.S_NATIONKEY
5 - HASH KEY : NATION.N_NATIONKEY
      RECORD COLUMN : NATION.N_NAME
      READ KEY COLUMN : NATION.N_NATIONKEY, NATION.N_NAME
      HASH FILTER : NATION.N_NATIONKEY = SUPPLIER.S_NATIONKEY
6 - SQL : SELECT /*+ FULL( _A1 ) */ "_A1"."N_NATIONKEY", "_A1"."N_NAME" FROM
"PUBLIC"."NATION"@LOCAL AS "_A1"
      TARGET DOMAIN : G3(G3N1,G3N2) 30 rows
7 - CLONED
      READ COLUMN : NATION.N_NATIONKEY, NATION.N_NAME
<<< end print plan

```

However, if it is performed as given above, the problem is that it should bring all data from the two tables.

Second, it configures the pusher table for a table, then performs the join query including the pusher table. In this case, a single group collects the data as follows.

```

gSQL> \EXPLAIN PLAN
      SELECT /*+ REMOTE_JOIN( supplier ) */ s_suppkey, n_name
      FROM supplier@g2, nation@g3
      WHERE s_nationkey = n_nationkey;
S_SUPPKEY N_NAME
-----
      4 CANADA
      1 FRANCE
      3 GERMANY
      2 INDIA
      5 UNITED STATES
5 rows selected.
>>> start print plan
< Execution Plan >
=====
|  IDX  |  NODE DESCRIPTION                               |  ROWS  |
-----|-----|-----|
|    0  |  SELECT STATEMENT                               |        5 |

```

```

1	QUERY BLOCK ("QB_IDX_2")	5	
2	SINGLE CLUSTER	REMOTE ONLY	5
3	CLUSTER PUSHER ("$_NI_7")	5	
4	PLAN BASED CLUSTER	REMOTE ONLY	5
5	TABLE ACCESS ("SUPPLIER")	0	
6	HASH JOIN (INNER JOIN)	0	
7	TABLE ACCESS ("NATION")	0	
8	HASH JOIN INSTANT	0	
9	PUSHER TABLE ACCESS ("$_NI_7")	0	
=====
1 - TARGET : $_NI_7.S_SUPPKEY, NATION.N_NAME
2 - SQL : SELECT /*+ KEEP_JOINED_TABLE USE_HASH_IN( _A1, 5 ) FULL( _A2 ) FULL( _A1 ) */
"_A1"."S_SUPPKEY", "_A2"."N_NAME" FROM ( "PUBLIC"."NATION"@LOCAL AS "_A2" INNER JOIN
"SESSION_SCHEMA"."$_NI_7"@LOCAL AS "_A1" ON "_A1"."S_NATIONKEY" = "_A2"."N_NATIONKEY") ALIAS
"_A3"
TARGET DOMAIN : G3(G3N1,G3N2) 5 rows
3 - SQL : DECLARE INSTANT TABLE "SESSION_SCHEMA"."$_NI_7" ( "S_NATIONKEY" NUMBER(10,
0), "S_SUPPKEY" NUMBER(10, 0) )
COLUMN : SUPPLIER.S_NATIONKEY AS S_NATIONKEY, SUPPLIER.S_SUPPKEY AS S_SUPPKEY
CLONED
TARGET DOMAIN : G3(G3N1,G3N2) 5 rows
4 - SQL : SELECT /*+ FULL( _A1 ) */ "_A1"."S_SUPPKEY", "_A1"."S_NATIONKEY" FROM
"PUBLIC"."SUPPLIER"@LOCAL AS "_A1"
TARGET DOMAIN : G2(G2N1,G2N2) 5 rows
5 - CLONED
READ COLUMN : SUPPLIER.S_SUPPKEY, SUPPLIER.S_NATIONKEY
6 - JOINED COLUMN : $_NI_7.S_SUPPKEY, NATION.N_NAME
7 - CLONED
READ COLUMN : NATION.N_NATIONKEY, NATION.N_NAME
8 - HASH KEY : $_NI_7.S_NATIONKEY
RECORD COLUMN : $_NI_7.S_SUPPKEY
READ KEY COLUMN : $_NI_7.S_NATIONKEY, $_NI_7.S_SUPPKEY
HASH FILTER : $_NI_7.S_NATIONKEY = NATION.N_NATIONKEY
<<< end print plan

```

When performing the join by collecting the data from multiple groups, then the data should be collected from multiple groups when processing the query because the data are distributed into multiple groups in the sharded table.

Joins including the sharded table are classified as follows.

- Case 1: Joining sharded table and cloned table

- The cloned table data is distributed to all groups where sharded table data were distributed.
- Case 2: Joining sharded table and cloned table
  - The cloned table data is not distributed to one or more groups where sharded table data were distributed.
- Case 3: Joining sharded table and sharded table
  - Equi-join condition between sharding keys of two sharded tables exists.
- Case 4: Joining sharded table and sharded table
  - Equi-join condition using the sharding key of a sharded table exists.
- Case 5: Joining sharded table and sharded table
  - Equi-join condition using the sharding key does not exist.

In case 1, if the cloned table data exists in all groups where the sharded table data is distributed, then the total sum of join results from each group becomes the entire join result.

```
gSQL> \EXPLAIN PLAN
      SELECT ps_partkey, s_name
      FROM partsupp, supplier
      WHERE ps_suppkey = s_suppkey;
```

```
PS_PARTKEY S_NAME
```

```
-----
      3 Supplier#1
      3 Supplier#4
      2 Supplier#2
      2 Supplier#5
      5 Supplier#1
      5 Supplier#4
      1 Supplier#2
      1 Supplier#3
      4 Supplier#3
      4 Supplier#5
```

```
10 rows selected.
```

```
>>> start print plan
```

```
< Execution Plan >
```

```
=====
|IDX| NODE DESCRIPTION                               |          ROWS |
-----|-----|
| 0 | SELECT STATEMENT                                 |             10 |
| 1 | QUERY BLOCK ("SQB_IDX_2")                       |             10 |
| 2 | PLAN BASED CLUSTER                            | LOCAL/REMOTE 10 |
| 3 | HASH JOIN (INNER JOIN)                         |              2 |
| 4 | INDEX ACCESS ("PARTSUPP", "PARTSUPP_PK_INDEX") | ( 2)          2 |
| 5 | HASH JOIN INSTANT                              |              2 |
```

```

| 6 |      TABLE ACCESS ("SUPPLIER")                |          5 |
=====
1 - TARGET : PARTSUPP.PS_PARTKEY, SUPPLIER.S_NAME
2 - SQL : SELECT /*+ KEEP_JOINED_TABLE USE_HASH_IN( _A1, 5 ) INDEX( _A2,
"PUBLIC"."PARTSUPP_PK_INDEX" ) FULL( _A1 ) */ "_A2"."PS_PARTKEY", "_A1"."S_NAME" FROM (
"PUBLIC"."PARTSUPP"@LOCAL AS "_A2" INNER JOIN "PUBLIC"."SUPPLIER"@LOCAL AS "_A1" ON
"_A1"."S_SUPPKEY" = "_A2"."PS_SUPPKEY") ALIAS "_A3"
      TARGET DOMAIN : G1(G1N1,G1N2) 2 rows, G2(G2N1,G2N2) 4 rows, G3(G3N1,G3N2) 4 rows
3 - JOINED COLUMN : PARTSUPP.PS_PARTKEY, SUPPLIER.S_NAME
4 - HASH SHARD ( # 3 )
      READ INDEX COLUMN : PARTSUPP.PS_PARTKEY, PARTSUPP.PS_SUPPKEY
5 - HASH KEY : SUPPLIER.S_SUPPKEY
      RECORD COLUMN : SUPPLIER.S_NAME
      READ KEY COLUMN : SUPPLIER.S_SUPPKEY, SUPPLIER.S_NAME
      HASH FILTER : SUPPLIER.S_SUPPKEY = PARTSUPP.PS_SUPPKEY
      FETCH ONE ROW
6 - CLONED
      READ COLUMN : SUPPLIER.S_SUPPKEY, SUPPLIER.S_NAME
<<< end print plan

```

In case 2, it can not configure the generated query including the join. In this case, it configures the cluster puller for each table which is a join target, then performs the join as follows.

```

gSQL> \EXPLAIN PLAN
      SELECT ps_partkey, s_name
      FROM partsupp, supplier@G2|G3
      WHERE ps_suppkey = s_suppkey;
PS_PARTKEY S_NAME
-----
3 Supplier#1
3 Supplier#4
1 Supplier#2
1 Supplier#3
4 Supplier#3
4 Supplier#5
2 Supplier#2
2 Supplier#5
5 Supplier#1
5 Supplier#4
10 rows selected.
>>> start print plan

```



< Execution Plan >

```

=====
|IDX| NODE DESCRIPTION                               |          ROWS |
-----
0	SELECT STATEMENT	10
1	QUERY BLOCK ("$_QB_IDX_2")	10
2	HASH JOIN (INNER JOIN)	10
3	PLAN BASED CLUSTER	LOCAL/REMOTE 10
4	INDEX ACCESS ("PARTSUPP", "PARTSUPP_PK_INDEX")	(    2)        2
5	HASH JOIN INSTANT	10
6	PLAN BASED CLUSTER	REMOTE ONLY   5
7	TABLE ACCESS ("SUPPLIER")	0
=====

  1 - TARGET : PARTSUPP.PS_PARTKEY, SUPPLIER.S_NAME
  2 - JOINED COLUMN : PARTSUPP.PS_PARTKEY, SUPPLIER.S_NAME
  3 - SQL : SELECT /*+ INDEX( _A1, "PUBLIC"."PARTSUPP_PK_INDEX" ) */ "_A1"."PS_PARTKEY",
"_A1"."PS_SUPPKEY" FROM "PUBLIC"."PARTSUPP"@LOCAL AS "_A1"
      TARGET DOMAIN : G1(G1N1,G1N2) 2 rows, G2(G2N1,G2N2) 4 rows, G3(G3N1,G3N2) 4 rows
  4 - HASH SHARD ( # 3 )
      READ INDEX COLUMN : PARTSUPP.PS_PARTKEY, PARTSUPP.PS_SUPPKEY
  5 - HASH KEY : SUPPLIER.S_SUPPKEY
      RECORD COLUMN : SUPPLIER.S_NAME
      READ KEY COLUMN : SUPPLIER.S_SUPPKEY, SUPPLIER.S_NAME
      HASH FILTER : SUPPLIER.S_SUPPKEY = PARTSUPP.PS_SUPPKEY
  6 - SQL : SELECT /*+ FULL( _A1 ) */ "_A1"."S_SUPPKEY", "_A1"."S_NAME" FROM
"PUBLIC"."SUPPLIER"@LOCAL AS "_A1"
      TARGET DOMAIN : G2(G2N1,G2N2) 5 rows, G3(G3N1,G3N2) 0 rows
  7 - CLONED
      READ COLUMN : SUPPLIER.S_SUPPKEY, SUPPLIER.S_NAME

<<< end print plan

```

In case 3, if sharding strategies for two tables are same, then the total sum of join results from each group is the entire join result. If sharding strategies of two tables are different, then the situation is as same as the case 4.

If sharding strategies of two tables are same, then the case 3 is performed as follows.

```

gSQL> \EXPLAIN PLAN
      SELECT p_name, ps_suppkey
      FROM part, partsupp
      WHERE p_partkey = ps_partkey;

P_NAME PS_SUPPKEY

```

```

-----
Part#3      4
Part#3      1
Part#2      5
Part#2      2
Part#5      4
Part#5      1
Part#1      3
Part#1      2
Part#4      5
Part#4      3
10 rows selected.
>>> start print plan
< Execution Plan >
=====
|IDX| NODE DESCRIPTION          |          ROWS |
-----
0	SELECT STATEMENT	10
1	QUERY BLOCK ("QOB_IDX_2")	10
2	PLAN BASED CLUSTER	LOCAL/REMOTE 10
3	HASH JOIN (INNER JOIN)	2
4	TABLE ACCESS ("PART")	1
5	HASH JOIN INSTANT	2
6	INDEX ACCESS ("PARTSUPP", "PARTSUPP_PK_INDEX")	( 2) 2
=====
1 - TARGET : PART.P_NAME, PARTSUPP.PS_SUPPKEY
2 - SQL : SELECT /*+ KEEP_JOINED_TABLE USE_HASH_IN( _A1, 10 ) FULL( _A2 ) INDEX( _A1,
"PUBLIC"."PARTSUPP_PK_INDEX" ) */ "_A2"."P_NAME", "_A1"."PS_SUPPKEY" FROM (
"PUBLIC"."PART"@LOCAL AS "_A2" INNER JOIN "PUBLIC"."PARTSUPP"@LOCAL AS "_A1" ON
"_A1"."PS_PARTKEY" = "_A2"."P_PARTKEY") ALIAS "_A3"
TARGET DOMAIN : G1(G1N1,G1N2) 2 rows, G2(G2N1,G2N2) 4 rows, G3(G3N1,G3N2) 4 rows
3 - JOINED COLUMN : PART.P_NAME, PARTSUPP.PS_SUPPKEY
4 - HASH SHARD ( # 3 )
READ COLUMN : PART.P_PARTKEY, PART.P_NAME
5 - HASH KEY : PARTSUPP.PS_PARTKEY
RECORD COLUMN : PARTSUPP.PS_SUPPKEY
READ KEY COLUMN : PARTSUPP.PS_PARTKEY, PARTSUPP.PS_SUPPKEY
HASH FILTER : PARTSUPP.PS_PARTKEY = PART.P_PARTKEY
6 - HASH SHARD ( # 3 )
READ INDEX COLUMN : PARTSUPP.PS_PARTKEY, PARTSUPP.PS_SUPPKEY
<<< end print plan

```

In case 4, it can not configure the generated query including the join for two sharded tables. It can process the join as same as the case of 1 by creating the pusher table for the opposite table of the table which used the sharding key in the equi-join condition.

The case 4 is performed for two sharded tables as follows.

```
gSQL> \EXPLAIN PLAN
      SELECT /*+ REMOTE_JOIN( part ) */ p_name, ps_suppkey
      FROM part, partsupp
      WHERE p_partkey = ps_suppkey;
P_NAME PS_SUPPKEY
-----
Part#3      3
Part#3      3
Part#1      1
Part#1      1
Part#4      4
Part#4      4
Part#2      2
Part#2      2
Part#5      5
Part#5      5
10 rows selected.
>>> start print plan
< Execution Plan >
=====
|IDX| NODE DESCRIPTION                               |          ROWS |
-----
0	SELECT STATEMENT	10
1	QUERY BLOCK ("$_QB_IDX_2")	10
2	SINGLE CLUSTER	LOCAL/REMOTE 10
3	CLUSTER PUSHER ("$_NI_7")	10
4	PLAN BASED CLUSTER	LOCAL/REMOTE 10
5	INDEX ACCESS ("PARTSUPP", "PARTSUPP_PK_INDEX")	( 2)         2
6	SELECT STATEMENT	2
7	QUERY BLOCK ("$_QB_IDX_2")	2
8	HASH JOIN (INNER JOIN)	2
9	TABLE ACCESS ("PART" AS _A2)	1
10	HASH JOIN INSTANT	2
11	PUSHER TABLE ACCESS ("$_NI_7" AS _A1)	2
=====
1 - TARGET : PART.P_NAME, $_NI_7.PS_SUPPKEY
```



```

0	SELECT STATEMENT	1
1	QUERY BLOCK ("$_QB_IDX_2")	1
2	SINGLE CLUSTER	LOCAL/REMOTE 1
3	CLUSTER PUSHER ("$_NI_6")	5
4	PLAN BASED CLUSTER	LOCAL/REMOTE 5
5	TABLE ACCESS ("PART" AS B)	1
6	SELECT STATEMENT	1
7	QUERY BLOCK ("$_QB_IDX_2")	1
8	AGGREGATION BY HASH	1
9	HASH JOIN (INNER JOIN)	2
10	PUSHER TABLE ACCESS ("$_NI_6" AS _A2)	5
11	HASH JOIN INSTANT	2
12	TABLE ACCESS ("PART" AS _A1)	1

```

```

=====
1 - TARGET : SUM( A.P_SIZE )
2 - SQL : SELECT /*+ KEEP_JOINED_TABLE USE_HASH_IN( _A1, 10 ) FULL( _A2 ) FULL( _A1 )
*/ SUM( "_A1".P_SIZE ) FROM ( "SESSION_SCHEMA"."$_NI_6"@LOCAL AS "_A2" INNER JOIN
"PUBLIC"."PART"@LOCAL AS "_A1" ON "_A1".P_TYPE" = "_A2".P_TYPE") ALIAS "_A3"
TARGET DOMAIN : G1(G1N1,G1N2) 1 rows, G2(G2N1,G2N2) 1 rows, G3(G3N1,G3N2) 1 rows
RE-AGGREGATION
AGGREGATION : SUM( SUM( A.P_SIZE ) )
3 - SQL : DECLARE INSTANT TABLE "SESSION_SCHEMA"."$_NI_6" ( "P_TYPE" VARCHAR(25 OCTETS)
)
COLUMN : B.P_TYPE AS P_TYPE
CLONED
TARGET DOMAIN : G1(G1N1,G1N2) 5 rows, G2(G2N1,G2N2) 5 rows, G3(G3N1,G3N2) 5 rows
4 - SQL : SELECT /*+ FULL( _A1 ) */ "_A1".P_TYPE FROM "PUBLIC"."PART"@LOCAL AS "_A1"
TARGET DOMAIN : G1(G1N1,G1N2) 1 rows, G2(G2N1,G2N2) 2 rows, G3(G3N1,G3N2) 2 rows
5 - HASH SHARD ( # 3 )
READ COLUMN : B.P_TYPE
7 - TARGET : SUM( _A1.P_SIZE )
8 - AGGREGATION : SUM( _A1.P_SIZE )
9 - JOINED COLUMN : _A1.P_SIZE
10 - READ COLUMN : _A2.P_TYPE
11 - HASH KEY : _A1.P_TYPE
RECORD COLUMN : _A1.P_SIZE
READ KEY COLUMN : _A1.P_TYPE, _A1.P_SIZE
HASH FILTER : _A1.P_TYPE = _A2.P_TYPE
12 - HASH SHARD ( # 3 )
READ COLUMN : _A1.P_TYPE, _A1.P_SIZE

```

```
<<< end print plan
```

## FROM Statement (Outer Join)

The query process in outer join is divided into the data collection from a single group and the data collection from multiple groups like as **FROM Statement (Join)**.

Outer join which collects data from a single group is applied only to a query which consists of cloned tables only or when the cluster domain is limited to a single group. It configures the join result by performing the generated query including the outer join in a single group as follows.

```
gSQL> \EXPLAIN PLAN
      SELECT s_suppkey, n_name
      FROM supplier@g2
      LEFT OUTER JOIN
      nation@g2
      ON s_nationkey = n_nationkey;
S_SUPPKEY N_NAME
-----
      4 CANADA
      1 FRANCE
      3 GERMANY
      2 INDIA
      5 UNITED STATES
5 rows selected.
>>> start print plan
< Execution Plan >
=====
|  IDX  |  NODE DESCRIPTION  |          ROWS |
-----|-----|-----|
|   0   |  SELECT STATEMENT  |              5 |
|   1   |  QUERY BLOCK ("$_QB_IDX_2") |              5 |
|   2   |      SINGLE CLUSTER | REMOTE ONLY 5 |
|   3   |  HASH JOIN (INVERTED LEFT OUTER JOIN) |              0 |
|   4   |  TABLE ACCESS ("NATION") |              0 |
|   5   |  HASH JOIN INSTANT |              0 |
|   6   |  TABLE ACCESS ("SUPPLIER") |              0 |
=====
1 - TARGET : SUPPLIER.S_SUPPKEY, NATION.N_NAME
2 - SQL : SELECT /*+ KEEP_JOINED_TABLE USE_HASH_IN( _A1, 5 ) FULL( _A2 ) FULL( _A1 ) */
"_A1".S_SUPPKEY, "_A2".N_NAME FROM ( "PUBLIC"."SUPPLIER"@G2N1|G2N2 AS "_A1" LEFT OUTER
JOIN "PUBLIC"."NATION"@G2N1|G2N2 AS "_A2" ON "_A1".S_NATIONKEY = "_A2".N_NATIONKEY")
ALIAS "_A3"
      TARGET DOMAIN : G2(G2N1,G2N2) 5 rows
```

```

3 - JOINED COLUMN : SUPPLIER.S_SUPPKEY, NATION.N_NAME
4 - CLONED
   READ COLUMN : NATION.N_NATIONKEY, NATION.N_NAME
5 - HASH KEY : SUPPLIER.S_NATIONKEY
   RECORD COLUMN : SUPPLIER.S_SUPPKEY
   READ KEY COLUMN : SUPPLIER.S_NATIONKEY, SUPPLIER.S_SUPPKEY
   HASH FILTER : SUPPLIER.S_NATIONKEY = NATION.N_NATIONKEY
6 - CLONED
   READ COLUMN : SUPPLIER.S_SUPPKEY, SUPPLIER.S_NATIONKEY

```

```
<<< end print plan
```

Outer join which collects data from multiple groups is applied to following three cases.

- Case 1: Joining sharded table and cloned table
  - The cloned table data is distributed to all groups where sharded table data were distributed.
- Case 2: Joining sharded table and sharded table
  - Equi-join condition between sharding keys of two sharded tables exists.
- Case 3: It includes one or more sharded tables and equi-join condition does not exists between sharding keys.

In case 1, it configures the generated query including the outer join.

The total sum of outer join results from each group becomes the entire join result as follows.

```

gSQL> \EXPLAIN PLAN
      SELECT p_name, ps_suppkey
      FROM part
      LEFT OUTER JOIN
      partsupp
      ON p_partkey = ps_partkey;
P_NAME PS_SUPPKEY
-----
Part#3      4
Part#3      1
Part#1      3
Part#1      2
Part#4      5
Part#4      3
Part#2      5
Part#2      2
Part#5      4
Part#5      1
10 rows selected.

```

```
>>> start print plan
```

```
< Execution Plan >
```

```
=====
```

|  | IDX | NODE DESCRIPTION                       |      | ROWS            |
|--|-----|----------------------------------------|------|-----------------|
|  | 0   | SELECT STATEMENT                       |      | 10              |
|  | 1   | QUERY BLOCK ("SQB_IDX_2")              |      | 10              |
|  | 2   | <b>SINGLE CLUSTER</b>                  |      | LOCAL/REMOTE 10 |
|  | 3   | SELECT STATEMENT                       |      | 2               |
|  | 4   | QUERY BLOCK ("SQB_IDX_2")              |      | 2               |
|  | 5   | HASH JOIN (LEFT OUTER JOIN)            |      | 2               |
|  | 6   | TABLE ACCESS ("PART" AS _A2)           |      | 1               |
|  | 7   | HASH JOIN INSTANT                      |      | 2               |
|  | 8   | INDEX ACCESS ("PARTSUPP" AS _A1, ... ) | ( 2) | 2               |

```
=====
```

```
1 - TARGET : PART.P_NAME, PARTSUPP.PS_SUPPKEY
2 - SQL : SELECT /*+ KEEP_JOINED_TABLE USE_HASH_IN( _A1, 10 ) FULL( _A2 ) INDEX( _A1,
"PUBLIC"."PARTSUPP_PK_INDEX" ) */ "_A2"."P_NAME", "_A1"."PS_SUPPKEY" FROM (
"PUBLIC"."PART"@G1N1"|"G1N2"|"G2N1"|"G2N2"|"G3N1"|"G3N2" AS "_A2" LEFT OUTER JOIN
"PUBLIC"."PARTSUPP"@G1N1"|"G1N2"|"G2N1"|"G2N2"|"G3N1"|"G3N2" AS "_A1" ON "_A1"."PS_PARTKEY" =
"_A2"."P_PARTKEY") ALIAS "_A3"
```

```
TARGET DOMAIN : G1(G1N1,G1N2) 2 rows, G2(G2N1,G2N2) 4 rows, G3(G3N1,G3N2) 4 rows
```

```
4 - TARGET : _A2.P_NAME, _A1.PS_SUPPKEY
5 - JOINED COLUMN : _A2.P_NAME, _A1.PS_SUPPKEY
6 - HASH SHARD ( # 3 )
READ COLUMN : _A2.P_PARTKEY, _A2.P_NAME
7 - HASH KEY : _A1.PS_PARTKEY
RECORD COLUMN : _A1.PS_SUPPKEY
READ KEY COLUMN : _A1.PS_PARTKEY, _A1.PS_SUPPKEY
HASH FILTER : _A1.PS_PARTKEY = _A2.P_PARTKEY
8 - HASH SHARD ( # 3 )
READ INDEX COLUMN : _A1.PS_PARTKEY, _A1.PS_SUPPKEY
```

```
<<< end print plan
```

In case 2, it configures the generated query including the outer join like as case 1.

The total sum of outer join results from each group becomes the entire join result as follows.

```
gSQL> \EXPLAIN PLAN
```

```
SELECT p_name, ps_suppkey
FROM part
LEFT OUTER JOIN
```



```

        partsupp
        ON p_partkey = ps_partkey;

```

```
P_NAME PS_SUPPKEY
```

```
-----
```

```

Part#3      4
Part#3      1
Part#1      3
Part#1      2
Part#4      5
Part#4      3
Part#2      5
Part#2      2
Part#5      4
Part#5      1

```

```
10 rows selected.
```

```
>>> start print plan
```

```
< Execution Plan >
```

```

=====
|IDX| NODE DESCRIPTION                               |          ROWS |
-----
0	SELECT STATEMENT	10
1	QUERY BLOCK (" $QB_IDX_2" )	10
2	SINGLE CLUSTER	LOCAL/REMOTE 10
3	SELECT STATEMENT	2
4	QUERY BLOCK (" $QB_IDX_2" )	2
5	HASH JOIN (LEFT OUTER JOIN)	2
6	TABLE ACCESS ("PART" AS _A2)	1
7	HASH JOIN INSTANT	2
8	INDEX ACCESS ("PARTSUPP" AS _A1, ... )	( 2)          2
=====

```

```

1 - TARGET : PART.P_NAME, PARTSUPP.PS_SUPPKEY
2 - SQL : SELECT /*+ KEEP_JOINED_TABLE USE_HASH_IN( _A1, 10 ) FULL( _A2 ) INDEX( _A1,
"PUBLIC"."PARTSUPP_PK_INDEX" ) */ "_A2"."P_NAME", "_A1"."PS_SUPPKEY" FROM (
"PUBLIC"."PART"@G1N1"|G1N2"|G2N1"|G2N2"|G3N1"|G3N2" AS "_A2" LEFT OUTER JOIN
"PUBLIC"."PARTSUPP"@G1N1"|G1N2"|G2N1"|G2N2"|G3N1"|G3N2" AS "_A1" ON "_A1"."PS_PARTKEY" =
"_A2"."P_PARTKEY") ALIAS "_A3"

```

```
TARGET DOMAIN : G1(G1N1,G1N2) 2 rows, G2(G2N1,G2N2) 4 rows, G3(G3N1,G3N2) 4 rows
```

```

4 - TARGET : _A2.P_NAME, _A1.PS_SUPPKEY
5 - JOINED COLUMN : _A2.P_NAME, _A1.PS_SUPPKEY
6 - HASH SHARD ( # 3 )
   READ COLUMN : _A2.P_PARTKEY, _A2.P_NAME

```

```

7 - HASH KEY : _A1.PS_PARTKEY
    RECORD COLUMN : _A1.PS_SUPPKEY
    READ KEY COLUMN : _A1.PS_PARTKEY, _A1.PS_SUPPKEY
    HASH FILTER : _A1.PS_PARTKEY = _A2.P_PARTKEY
8 - HASH SHARD ( # 3 )
    READ INDEX COLUMN : _A1.PS_PARTKEY, _A1.PS_SUPPKEY

```

```
<<< end print plan
```

In case 3, the total sum of the results of the generated query including the outer join from each group becomes the duplicate entire anti join result like as case 1. It manipulates the data in intersect key group method to delete the duplicate anti join results. For more information about the intersect key group, refer to **Generated Query for Intersect Key Group**.

The following is an example of processing the intersect key group for the outer join.

```

gSQL> \EXPLAIN PLAN
      SELECT /*+ REMOTE_JOIN( supplier ) */ ps_partkey, s_name
      FROM supplier
      LEFT OUTER JOIN
      partsupp
      ON ps_suppkey = s_suppkey;
PS_PARTKEY S_NAME
-----
3 Supplier#1
5 Supplier#1
2 Supplier#2
1 Supplier#2
1 Supplier#3
4 Supplier#3
3 Supplier#4
5 Supplier#4
2 Supplier#5
4 Supplier#5
10 rows selected.
>>> start print plan
< Execution Plan >
=====
|IDX| NODE DESCRIPTION                                |          ROWS |
-----
0	SELECT STATEMENT	10
1	QUERY BLOCK (" $QB_IDX_2" )	10
2	MULTIPLE CLUSTER	LOCAL/REMOTE 10

```

```

3	SELECT STATEMENT	5	
4	QUERY BLOCK ("SQB_IDX_2")	5	
5	SORT INSTANT	5	
6	HASH JOIN (INVERTED LEFT OUTER JOIN)	5	
7	INDEX ACCESS ("PARTSUPP" AS _A2, ...	( 2)	2
8	HASH JOIN INSTANT	5	
9	TABLE ACCESS ("SUPPLIER" AS _A1)	5	

```

```
=====
```

```

1 - TARGET : PARTSUPP.PS_PARTKEY, SUPPLIER.S_NAME
2 - SQL : SELECT /*+ KEEP_JOINED_TABLE USE_HASH_IN( _A1, 5 ) INDEX( _A2,
"PUBLIC"."PARTSUPP_PK_INDEX" ) FULL( _A1 ) */ "_A1"."S_SUPPKEY", "_A2"."PS_SUPPKEY",
"_A2"."PS_PARTKEY", "_A1"."S_NAME" FROM (
"PUBLIC"."SUPPLIER"@G1N1"!G1N2"!G2N1"!G2N2"!G3N1"!G3N2" AS "_A1" LEFT OUTER JOIN
"PUBLIC"."PARTSUPP"@G1N1"!G1N2"!G2N1"!G2N2"!G3N1"!G3N2" AS "_A2" ON "_A1"."S_SUPPKEY" =
"_A2"."PS_SUPPKEY") ALIAS "_A3" ORDER BY "_A1"."S_SUPPKEY" ASC NULLS LAST
    TARGET DOMAIN : G1(G1N1,G1N2) 5 rows, G2(G2N1,G2N2) 5 rows, G3(G3N1,G3N2) 6 rows
INTERSECT KEY GROUP
    KEY GROUP : SUPPLIER.S_SUPPKEY
    Nil Expression : PARTSUPP.PS_SUPPKEY
4 - TARGET : _A1.S_SUPPKEY, _A2.PS_SUPPKEY, _A2.PS_PARTKEY, _A1.S_NAME
5 - SORT KEY : "_A1.S_SUPPKEY ASC NULLS LAST"
    RECORD COLUMN : _A2.PS_SUPPKEY, _A2.PS_PARTKEY, _A1.S_NAME
    READ KEY COLUMN : _A1.S_SUPPKEY
    READ RECORD COLUMN : _A2.PS_SUPPKEY, _A2.PS_PARTKEY, _A1.S_NAME
6 - JOINED COLUMN : _A1.S_SUPPKEY, _A2.PS_SUPPKEY, _A2.PS_PARTKEY, _A1.S_NAME
7 - HASH SHARD ( # 3 )
    READ INDEX COLUMN : _A2.PS_PARTKEY, _A2.PS_SUPPKEY
8 - HASH KEY : _A1.S_SUPPKEY
    RECORD COLUMN : _A1.S_NAME
    READ KEY COLUMN : _A1.S_SUPPKEY, _A1.S_NAME
    HASH FILTER : _A1.S_SUPPKEY = _A2.PS_SUPPKEY
9 - CLONED
    READ COLUMN : _A1.S_SUPPKEY, _A1.S_NAME

```

```
<<< end print plan
```

The generated query includes the ordering for columns included in an equi-join condition as above. It collects data collected from each group in an order of the ordering, then applies the intersect key group only to the case whose nil expression value is null.

## FROM Statement (Join Including Subquery)

The join including the subquery is classified according to whether the subquery is used as a join condition. When processing the cluster of the join which does not use the subquery as a join condition, it collects and manipulates the data through the cluster puller, then applies the filter related to the subquery. The join which uses the subquery as a join condition processes the join according to the join operation.

The following is an example of processing the subquery which is not used as the join condition.

```
gSQL> \EXPLAIN PLAN
      SELECT p_name, ps_supkey
      FROM part, partsupp
      WHERE p_partkey = ps_partkey
            AND ps_supkey IN ( SELECT /*+ NO_UNNEST */ s_supkey FROM supplier );
```

```
P_NAME PS_SUPPKEY
```

```
-----
```

```
Part#3      4
Part#3      1
Part#2      5
Part#2      2
Part#5      4
Part#5      1
Part#1      3
Part#1      2
Part#4      5
Part#4      3
```

```
10 rows selected.
```

```
>>> start print plan
```

```
< Execution Plan >
```

```
=====
```

| IDX | NODE DESCRIPTION                      | ROWS            |
|-----|---------------------------------------|-----------------|
| 0   | SELECT STATEMENT                      | 10              |
| 1   | QUERY BLOCK ("QB_IDX_2")              | 10              |
| 2   | <b>PLAN BASED CLUSTER</b>             | LOCAL/REMOTE 10 |
| 3   | HASH JOIN (INNER JOIN)                | 2               |
| 4   | TABLE ACCESS ("PART")                 | 1               |
| 5   | HASH JOIN INSTANT                     | 2               |
| 6   | INDEX ACCESS ("PARTSUPP", ...)   ( 2) | 2               |
| 7   | SUB QUERY LIST                        |                 |
| 8   | INLINE_VIEW ("V8") (MATERIALIZED)     | 10              |
| 9   | QUERY BLOCK ("QB_IDX_8")              | 5               |

```

| 10 |          INDEX ACCESS ("SUPPLIER", ...) | ( 5) 5 |
=====
1 - TARGET : PART.P_NAME, PARTSUPP.PS_SUPPKEY
2 - SQL : SELECT /*+ KEEP_JOINED_TABLE USE_HASH_IN( _A1, 10 ) FULL( _A2 ) INDEX( _A1,
"PUBLIC"."PARTSUPP_PK_INDEX" ) */ "_A1"."PS_SUPPKEY", "_A2"."P_NAME" FROM (
"PUBLIC"."PART"@LOCAL AS "_A2" INNER JOIN "PUBLIC"."PARTSUPP"@LOCAL AS "_A1" ON
"_A1"."PS_PARTKEY" = "_A2"."P_PARTKEY") ALIAS "_A3"
      TARGET DOMAIN : G1(G1N1,G1N2) 2 rows, G2(G2N1,G2N2) 4 rows, G3(G3N1,G3N2) 4 rows
      POST FILTER : ( PARTSUPP.PS_SUPPKEY ) IN ( $V8.S_SUPPKEY )
3 - JOINED COLUMN : PARTSUPP.PS_SUPPKEY, PART.P_NAME
4 - HASH SHARD ( # 3 )
      READ COLUMN : PART.P_PARTKEY, PART.P_NAME
5 - HASH KEY : PARTSUPP.PS_PARTKEY
      RECORD COLUMN : PARTSUPP.PS_SUPPKEY
      READ KEY COLUMN : PARTSUPP.PS_PARTKEY, PARTSUPP.PS_SUPPKEY
      HASH FILTER : PARTSUPP.PS_PARTKEY = PART.P_PARTKEY
6 - HASH SHARD ( # 3 )
      READ INDEX COLUMN : PARTSUPP.PS_PARTKEY, PARTSUPP.PS_SUPPKEY
8 - COLUMN : SUPPLIER.S_SUPPKEY AS S_SUPPKEY
9 - TARGET : SUPPLIER.S_SUPPKEY
10 - CLONED
      READ INDEX COLUMN : SUPPLIER.S_SUPPKEY
<<< end print plan

```

Joins which use the subquery as a join condition are classified according to the operator including the subquery as follows.

**Table 12-11** Join including subquery

| Join operation | Operator including the subquery                                         |
|----------------|-------------------------------------------------------------------------|
| INNER JOIN     | All operators except for <Group Comparison Conditions>                  |
| OUTER JOIN     | All operators except for <Group Comparison Conditions>                  |
| SEMI JOIN      | <Group Comparison Conditions> having EXISTS, IN, ANY quantifier         |
| ANTI-SEMI JOIN | <Group Comparison Conditions> having NOT EXISTS, NOT IN, ALL quantifier |

For more information about the join operation, refer to **Join**.

If a join condition or a filter, which includes a subquery is used in an inner join, then it collects the data and applies the filter related to the subquery as follows.

```

gSQL> \EXPLAIN PLAN
      SELECT ps_partkey, s_name
      FROM supplier

```

```

INNER JOIN
partsupp
ON ps_suppkey = s_suppkey
AND ps_suppkey = ( SELECT s_suppkey FROM DUAL );

```

```
PS_PARTKEY S_NAME
```

```

-----
3 Supplier#1
3 Supplier#4
1 Supplier#2
1 Supplier#3
4 Supplier#3
4 Supplier#5
2 Supplier#2
2 Supplier#5
5 Supplier#1
5 Supplier#4

```

10 rows selected.

```
>>> start print plan
```

```
< Execution Plan >
```

```

=====
IDX	NODE DESCRIPTION	ROWS
0	SELECT STATEMENT	10
1	QUERY BLOCK ("QB_IDX_2")	10
2	PLAN BASED CLUSTER	LOCAL/REMOTE 10
3	HASH JOIN (INNER JOIN)	2
4	INDEX ACCESS ("PARTSUPP", ...)	( 2)           2
5	HASH JOIN INSTANT	2
6	TABLE ACCESS ("SUPPLIER")	5
7	SUB QUERY LIST	
8	INLINE_VIEW ("V8")	10
9	QUERY BLOCK ("QB_IDX_8")	10
10	FAST DUAL ACCESS ("DUAL")	10
=====

```

```
1 - TARGET : PARTSUPP.PS_PARTKEY, SUPPLIER.S_NAME
```

```

2 - SQL : SELECT /*+ KEEP_JOINED_TABLE USE_HASH_IN( _A1, 5 ) INDEX( _A2,
"PUBLIC"."PARTSUPP_PK_INDEX" ) FULL( _A1 ) */ "_A2"."PS_SUPPKEY", "_A1"."S_SUPPKEY",
"_A2"."PS_PARTKEY", "_A1"."S_NAME" FROM ( "PUBLIC"."PARTSUPP"@LOCAL AS "_A2" INNER JOIN
"PUBLIC"."SUPPLIER"@LOCAL AS "_A1" ON "_A1"."S_SUPPKEY" = "_A2"."PS_SUPPKEY") ALIAS "_A3"

```

```
TARGET DOMAIN : G1(G1N1,G1N2) 2 rows, G2(G2N1,G2N2) 4 rows, G3(G3N1,G3N2) 4 rows
```

```
POST FILTER : PARTSUPP.PS_SUPPKEY = V8.S_SUPPKEY
```

```

3 - JOINED COLUMN : PARTSUPP.PS_SUPPKEY, SUPPLIER.S_SUPPKEY, PARTSUPP.PS_PARTKEY,
SUPPLIER.S_NAME
4 - HASH SHARD ( # 3 )
   READ INDEX COLUMN : PARTSUPP.PS_PARTKEY, PARTSUPP.PS_SUPPKEY
5 - HASH KEY : SUPPLIER.S_SUPPKEY
   RECORD COLUMN : SUPPLIER.S_NAME
   READ KEY COLUMN : SUPPLIER.S_SUPPKEY, SUPPLIER.S_NAME
   HASH FILTER : SUPPLIER.S_SUPPKEY = PARTSUPP.PS_SUPPKEY
   FETCH ONE ROW
6 - CLONED
   READ COLUMN : SUPPLIER.S_SUPPKEY, SUPPLIER.S_NAME
8 - COLUMN : {SUPPLIER.S_SUPPKEY} AS S_SUPPKEY
9 - TARGET : {SUPPLIER.S_SUPPKEY}
10 - READ COLUMN : NOTHING
<<< end print plan

```

If a join condition including a subquery exists in an outer join, then it can not configure the generated query including the outer join.

In this case, perform the join by configuring the cluster puller per each join target table as follows.

```

gSQL> \EXPLAIN PLAN
      SELECT ps_partkey, s_name
      FROM supplier
      LEFT OUTER JOIN
      partsupp
      ON ps_suppkey = ( SELECT s_suppkey FROM DUAL );
PS_PARTKEY S_NAME
-----
3 Supplier#1
5 Supplier#1
2 Supplier#2
1 Supplier#2
1 Supplier#3
4 Supplier#3
3 Supplier#4
5 Supplier#4
4 Supplier#5
2 Supplier#5
10 rows selected.
>>> start print plan
< Execution Plan >

```

```

=====
|  IDX  |  NODE DESCRIPTION  |  ROWS  |
=====
0	SELECT STATEMENT	
1	QUERY BLOCK ("QB_IDX_2")	
2	NESTED JOIN (LEFT OUTER JOIN)	
3	TABLE ACCESS ("SUPPLIER")	
4	PLAN BASED CLUSTER	LOCAL/REMOTE  50
5	INDEX ACCESS ("PARTSUPP", ...)	( 10)  10
6	SUB QUERY LIST	
7	INLINE_VIEW ("V7")	
8	QUERY BLOCK ("QB_IDX_8")	
9	FAST DUAL ACCESS ("DUAL")	
=====
1 - TARGET : PARTSUPP.PS_PARTKEY, SUPPLIER.S_NAME
2 - JOINED COLUMN : PARTSUPP.PS_SUPPKEY, SUPPLIER.S_SUPPKEY, PARTSUPP.PS_PARTKEY,
SUPPLIER.S_NAME
   POST ON FILTER : PARTSUPP.PS_SUPPKEY = V7.S_SUPPKEY
3 - CLONED
   READ COLUMN : SUPPLIER.S_SUPPKEY, SUPPLIER.S_NAME
4 - SQL : SELECT /*+ INDEX( _A1, "PUBLIC"."PARTSUPP_PK_INDEX" )*/ "_A1"."PS_PARTKEY",
"_A1"."PS_SUPPKEY" FROM "PUBLIC"."PARTSUPP"@LOCAL AS "_A1"
   TARGET DOMAIN : G1(G1N1,G1N2) 10 rows, G2(G2N1,G2N2) 20 rows, G3(G3N1,G3N2) 20 rows
5 - HASH SHARD ( # 3 )
   READ INDEX COLUMN : PARTSUPP.PS_PARTKEY, PARTSUPP.PS_SUPPKEY
7 - COLUMN : {SUPPLIER.S_SUPPKEY} AS S_SUPPKEY
8 - TARGET : {SUPPLIER.S_SUPPKEY}
9 - READ COLUMN : NOTHING
<<< end print plan

```

The filter including a subquery in an outer join is not included in the generated query. The cluster puller for an outer join collects and manipulates the data, then performs filters which are not included in the generated query.

The following is an example of processing a filter including a subquery in an outer join.

```

gSQL> \EXPLAIN PLAN
      SELECT p_name, ps_suppkey
      FROM partsupp
      LEFT OUTER JOIN
      part
      ON p_partkey = ps_partkey

```



```
WHERE ps_supplycost > ( SELECT p_retailprice FROM supplier WHERE s_suppkey = ps_suppkey
);
```

```
P_NAME PS_SUPPKEY
```

```
-----
Part#3          4
Part#1          2
Part#5          1
```

```
3 rows selected.
```

```
>>> start print plan
```

```
< Execution Plan >
```

```
=====
|  IDX  |  NODE DESCRIPTION                               |          ROWS |
=====
0	SELECT STATEMENT	3
1	QUERY BLOCK ("SQB_IDX_2")	3
2	SINGLE CLUSTER	LOCAL/REMOTE 3
3	SELECT STATEMENT	2
4	QUERY BLOCK ("SQB_IDX_2")	2
5	HASH JOIN (LEFT OUTER JOIN)	2
6	TABLE ACCESS ("PARTSUPP" AS _A2)	2
7	HASH JOIN INSTANT	2
8	TABLE ACCESS ("PART" AS _A1)	1
9	SUB QUERY LIST	1
10	INLINE_VIEW ("V8")	10
11	QUERY BLOCK ("SQB_IDX_8")	10
12	INDEX ACCESS ("SUPPLIER", ...)	( 10) 10
=====
```

```
1 - TARGET : PART.P_NAME, PARTSUPP.PS_SUPPKEY
2 - SQL : SELECT /*+ KEEP_JOINED_TABLE USE_HASH_IN( _A1, 500 ) FULL( _A2 ) FULL( _A1 )
*/ "_A2"."PS_SUPPLYCOST", "_A2"."PS_SUPPKEY", "_A1"."P_RETAILPRICE", "_A1"."P_NAME" FROM (
"PUBLIC"."PARTSUPP"@G1N1|G1N2|G2N1|G2N2|G3N1|G3N2 AS "_A2" LEFT OUTER JOIN
"PUBLIC"."PART"@G1N1|G1N2|G2N1|G2N2|G3N1|G3N2 AS "_A1" ON "_A1"."P_PARTKEY" =
"_A2"."PS_PARTKEY") ALIAS "_A3"
```

```
TARGET DOMAIN : G1(G1N1,G1N2) 2 rows, G2(G2N1,G2N2) 4 rows, G3(G3N1,G3N2) 4 rows
```

```
POST FILTER : PARTSUPP.PS_SUPPLYCOST > V8.P_RETAILPRICE
```

```
4 - TARGET : _A2.PS_SUPPLYCOST, _A2.PS_SUPPKEY, _A1.P_RETAILPRICE, _A1.P_NAME
5 - JOINED COLUMN : _A2.PS_SUPPLYCOST, _A2.PS_SUPPKEY, _A1.P_RETAILPRICE, _A1.P_NAME
6 - HASH SHARD ( # 3 )
READ COLUMN : _A2.PS_PARTKEY, _A2.PS_SUPPKEY, _A2.PS_SUPPLYCOST
7 - HASH KEY : _A1.P_PARTKEY
RECORD COLUMN : _A1.P_RETAILPRICE, _A1.P_NAME
```

```

      READ KEY COLUMN : _A1.P_PARTKEY, _A1.P_RETAILPRICE, _A1.P_NAME
      HASH FILTER : _A1.P_PARTKEY = _A2.PS_PARTKEY
      FETCH ONE ROW
8 - HASH SHARD ( # 3 )
      READ COLUMN : _A1.P_PARTKEY, _A1.P_NAME, _A1.P_RETAILPRICE
10 - COLUMN : {PART.P_RETAILPRICE} AS P_RETAILPRICE
11 - TARGET : {PART.P_RETAILPRICE}
12 - CLONED
      READ INDEX COLUMN : SUPPLIER.S_SUPPKEY
      MIN RANGE : SUPPLIER.S_SUPPKEY = {PARTSUPP.PS_SUPPKEY}
      MAX RANGE : SUPPLIER.S_SUPPKEY = {PARTSUPP.PS_SUPPKEY}
      FETCH ONE ROW
<<< end print plan

```

When a subquery specified in where statement is converted into a semi join by performing <subquery unnest>, then the generated query to process the semi join includes the semi join statement. The total sum of generated query results from multiple groups becomes the duplicate semi join result. Then, it manipulates the data in distinct key group method to delete the duplicate semi join results. For more information about distinct key group, refer to **Generated Query for Distinct Key Group**.

The following is an example of processing the distinct key group for the semi join.

```

gSQL> \EXPLAIN PLAN
      SELECT s_name
      FROM supplier
      WHERE s_suppkey IN ( SELECT /*+ REMOTE_UNNEST */ ps_suppkey FROM partsupp );
S_NAME
-----
Supplier#1
Supplier#2
Supplier#3
Supplier#4
Supplier#5
5 rows selected.
>>> start print plan
< Execution Plan >
=====
|IDX|  NODE DESCRIPTION                                |          ROWS |
-----|-----|
| 0 | SELECT STATEMENT                                    |              5 |
| 1 |  QUERY BLOCK ("SQB_IDX_2")                          |              5 |
| 2 |    MULTIPLE CLUSTER                               | LOCAL/REMOTE 5 |

```

```

3	SELECT STATEMENT	2	
4	QUERY BLOCK ("SQB_IDX_2")	2	
5	SORT INSTANT	2	
6	HASH JOIN (INVERTED SEMI)	2	
7	INDEX ACCESS ("PARTSUPP" AS _A2, ...)	( 2)	2
8	HASH JOIN INSTANT	2	
9	TABLE ACCESS ("SUPPLIER" AS _A1)	5	
=====
1 - TARGET : SUPPLIER.S_NAME
2 - SQL : SELECT /*+ KEEP_JOINED_TABLE USE_HASH_IN( _A1, 5 ) INDEX( _A2,
"PUBLIC"."PARTSUPP_PK_INDEX" ) FULL( _A1 ) */ "_A1"."S_SUPPKEY", "_A1"."S_NAME" FROM (
"PUBLIC"."SUPPLIER"@G1N1|G1N2|G2N1|G2N2|G3N1|G3N2 AS "_A1" SEMI JOIN
"PUBLIC"."PARTSUPP"@G1N1|G1N2|G2N1|G2N2|G3N1|G3N2 AS "_A2" ON "_A1"."S_SUPPKEY" =
"_A2"."PS_SUPPKEY") ALIAS "_A3" ORDER BY "_A1"."S_SUPPKEY" ASC NULLS LAST
TARGET DOMAIN : G1(G1N1,G1N2) 2 rows, G2(G2N1,G2N2) 4 rows, G3(G3N1,G3N2) 3 rows
DISTINCT KEY GROUP
KEY GROUP : SUPPLIER.S_SUPPKEY
4 - TARGET : _A1.S_SUPPKEY, _A1.S_NAME
5 - SORT KEY : "_A1.S_SUPPKEY ASC NULLS LAST"
RECORD COLUMN : _A1.S_NAME
READ KEY COLUMN : _A1.S_SUPPKEY
READ RECORD COLUMN : _A1.S_NAME
6 - JOINED COLUMN : _A1.S_SUPPKEY, _A1.S_NAME
7 - HASH SHARD ( # 3 )
READ INDEX COLUMN : _A2.PS_SUPPKEY
8 - HASH KEY : _A1.S_SUPPKEY
RECORD COLUMN : _A1.S_NAME
READ KEY COLUMN : _A1.S_SUPPKEY, _A1.S_NAME
HASH FILTER : _A1.S_SUPPKEY = _A2.PS_SUPPKEY
9 - CLONED
READ COLUMN : _A1.S_SUPPKEY, _A1.S_NAME
<<< end print plan

```

When a subquery specified in where statement is converted into an anti-semi join by performing <subquery unnest>, then the generated query to process the anti-semi join includes the anti-semi join statement. The total sum of generated query results from multiple groups becomes the duplicate anti-semi join result. Then, it manipulates the data in intersect key group method to delete the duplicate anti-semi join results. For more information about intersect key group, refer to **Generated Query for Intersect Key Group**.

The following is an example of processing the intersect key group for the anti-semi join.

```

gSQL> \EXPLAIN PLAN
      SELECT s_name
      FROM supplier
      WHERE s_suppkey NOT IN ( SELECT /*+ REMOTE_UNNEST */ ps_suppkey FROM partsupp WHERE
ps_supplycost > 900 );

```

S\_NAME

-----

Supplier#3

Supplier#5

2 rows selected.

>>> start print plan

< Execution Plan >

```

=====
|IDX|  NODE DESCRIPTION                               |          ROWS |
=====
0	SELECT STATEMENT	2
1	QUERY BLOCK ("$_QB_IDX_2")	2
2	MULTIPLE CLUSTER	LOCAL/REMOTE 2
3	SELECT STATEMENT	4
4	QUERY BLOCK ("$_QB_IDX_2")	4
5	SORT INSTANT	4
6	HASH JOIN (ANTI SEMI)	4
7	TABLE ACCESS ("SUPPLIER" AS _A2)	5
8	HASH JOIN INSTANT (UNIQUE)	4
9	TABLE ACCESS ("PARTSUPP" AS _A1)	1
=====

```

```

1 - TARGET : SUPPLIER.S_NAME
2 - SQL : SELECT /*+ KEEP_JOINED_TABLE USE_HASH_IN( _A1, 10 ) FULL( _A2 ) FULL( _A1 )
*/ "_A2"."S_SUPPKEY", "_A2"."S_NAME" FROM (
"PUBLIC"."SUPPLIER"@G1N1|G1N2|G2N1|G2N2|G3N1|G3N2 AS "_A2" ANTI SEMI JOIN
"PUBLIC"."PARTSUPP"@G1N1|G1N2|G2N1|G2N2|G3N1|G3N2 AS "_A1" ON "_A1"."PS_SUPPKEY" =
"_A2"."S_SUPPKEY" AND "_A1"."PS_SUPPLYCOST" > :_V0) ALIAS "_A3" ORDER BY "_A2"."S_SUPPKEY" ASC
NULLS LAST

```

TARGET DOMAIN : G1(G1N1,G1N2) 4 rows, G2(G2N1,G2N2) 4 rows, G3(G3N1,G3N2) 4 rows

**INTERSECT KEY GROUP**

KEY GROUP : SUPPLIER.S\_SUPPKEY

4 - TARGET : \_A2.S\_SUPPKEY, \_A2.S\_NAME

5 - SORT KEY : "\_A2.S\_SUPPKEY ASC NULLS LAST"

RECORD COLUMN : \_A2.S\_NAME

READ KEY COLUMN : \_A2.S\_SUPPKEY

READ RECORD COLUMN : \_A2.S\_NAME

```

6 - JOINED COLUMN : _A2.S_SUPPKEY, _A2.S_NAME
7 - CLONED
   READ COLUMN : _A2.S_SUPPKEY, _A2.S_NAME
8 - HASH KEY : _A1.PS_SUPPKEY
   READ KEY COLUMN : _A1.PS_SUPPKEY
   HASH FILTER : _A1.PS_SUPPKEY = _A2.S_SUPPKEY
   FETCH ONE ROW
9 - HASH SHARD ( # 3 )
   READ COLUMN : _A1.PS_SUPPKEY, _A1.PS_SUPPLYCOST
   PHYSICAL FILTER : _A1.PS_SUPPLYCOST > :_V0
<<< end print plan

```

## WHERE Statement

Filter configured on plan node are classified as follows.

- Constant filter: This filter is processed by being made into a constant in plan node unit.
- Post filter: This filter includes a subquery or it consists of non-deterministic expressions.
- Filter: This filter is the rest of what is not classified as a constant filter or a post filter.

The generated query configures the cluster puller and the filter belonging to the subordinate node into a query. It configures the query in a bind parameter form by making a constant filter into a constant, and configures the filter into a query without modification. However, it does not configure the generated query for a post filter.

The following is an example of the generated query including a constant filter.

```

gSQL> \VAR v1 INTEGER
gSQL> \EXEC :v1 := 1
gSQL> \EXPLAIN PLAN
      SELECT p_name, p_brand, p_type, cluster_group_id
         FROM part
        WHERE :v1 = 1;

```

| P_NAME | P_BRAND | P_TYPE | CLUSTER_GROUP_ID |
|--------|---------|--------|------------------|
| Part#3 | Brand#2 | STEEL  | 1                |
| Part#2 | Brand#1 | NICKEL | 2                |
| Part#5 | Brand#3 | STEEL  | 2                |
| Part#1 | Brand#1 | COPPER | 3                |
| Part#4 | Brand#3 | NICKEL | 3                |

```

5 rows selected.
>>> start print plan

```

< Execution Plan >

```
=====
IDX	NODE DESCRIPTION	ROWS
0	SELECT STATEMENT	
1	QUERY BLOCK ("$_QB_IDX_2")	
2	PLAN BASED CLUSTER	LOCAL/REMOTE
3	TABLE ACCESS ("PART")	
=====
```

```
1 - TARGET : PART.P_NAME, PART.P_BRAND, PART.P_TYPE, PART.CLUSTER_GROUP_ID
2 - SQL : SELECT /*+ FULL( _A1 ) */ "_A1"."CLUSTER_GROUP_ID", "_A1"."P_NAME",
"_A1"."P_BRAND", "_A1"."P_TYPE" FROM "PUBLIC"."PART"@LOCAL AS "_A1" WHERE :_V0
TARGET DOMAIN : G1(G1N1,G1N2) 1 rows, G2(G2N1,G2N2) 2 rows, G3(G3N1,G3N2) 2 rows
CONSTANT FILTER : :V1 = 1
3 - HASH SHARD ( # 3 )
READ COLUMN : PART.P_NAME, PART.P_BRAND, PART.P_TYPE
CONSTANT FILTER : :V1 = 1
```

<<< end print plan

The following is an example of the generated query including a subordinate filter of the cluster puller.

gSQL> \EXPLAIN PLAN

```
SELECT p_name, p_brand, p_type, cluster_group_id
FROM part
WHERE p_partkey = 1;
```

```
P_NAME P_BRAND P_TYPE CLUSTER_GROUP_ID
-----|-----|-----|
Part#1 Brand#1 COPPER 3
```

1 row selected.

>>> start print plan

< Execution Plan >

```
=====
IDX	NODE DESCRIPTION	ROWS
0	SELECT STATEMENT	
1	QUERY BLOCK ("$_QB_IDX_2")	
2	PLAN BASED CLUSTER	REMOTE ONLY
3	INDEX ACCESS ("PART", "PART_PK_INDEX")	( 0) 0
=====
```

```
1 - TARGET : PART.P_NAME, PART.P_BRAND, PART.P_TYPE, PART.CLUSTER_GROUP_ID
2 - SQL : SELECT /*+ INDEX( _A1, "PUBLIC"."PART_PK_INDEX" ) */
```

```

"_A1"."CLUSTER_GROUP_ID", "_A1"."P_NAME", "_A1"."P_BRAND", "_A1"."P_TYPE" FROM
"PUBLIC"."PART"@LOCAL AS "_A1" WHERE "_A1"."P_PARTKEY" = :_V0
    TARGET DOMAIN : G3(G3N1,G3N2) 1 rows
3 - HASH SHARD ( # 3 )
    READ INDEX COLUMN : PART.P_PARTKEY
    READ TABLE COLUMN : PART.P_NAME, PART.P_BRAND, PART.P_TYPE
    MIN RANGE : PART.P_PARTKEY = 1
    MAX RANGE : PART.P_PARTKEY = 1
    FETCH ONE ROW
<<< end print plan

```

The following is an example of the generated query of when the cluster puller has a post filter.

```

gSQL> \EXPLAIN PLAN
    SELECT p_name, p_brand, p_type, cluster_group_id
    FROM part
    WHERE p_name = 'Part#5' AND p_partkey IN ( SELECT /*+ NO_UNNEST */ p_partkey FROM DUAL
);
P_NAME P_BRAND   P_TYPE CLUSTER_GROUP_ID
-----
Part#5 Brand#3   STEEL          2
1 row selected.
>>> start print plan
< Execution Plan >
=====
|  IDX  |  NODE DESCRIPTION                               |  ROWS  |
-----
0	SELECT STATEMENT	
1	QUERY BLOCK ("$_QB_IDX_2")	
2	PLAN BASED CLUSTER	LOCAL/REMOTE
3	TABLE ACCESS ("PART")	
4	SUB QUERY LIST	
5	INLINE_VIEW ("$_V5")	
6	QUERY BLOCK ("$_QB_IDX_6")	
7	FAST DUAL ACCESS ("DUAL")	
=====
1 - TARGET : PART.P_NAME, PART.P_BRAND, PART.P_TYPE, PART.CLUSTER_GROUP_ID
2 - SQL : SELECT /*+ FULL( _A1 ) */ "_A1"."CLUSTER_GROUP_ID", "_A1"."P_PARTKEY",
"_A1"."P_NAME", "_A1"."P_BRAND", "_A1"."P_TYPE" FROM "PUBLIC"."PART"@LOCAL AS "_A1" WHERE
"_A1"."P_NAME" = :_V0
    TARGET DOMAIN : G1(G1N1,G1N2) 0 rows, G2(G2N1,G2N2) 1 rows, G3(G3N1,G3N2) 0 rows

```

```

          POST FILTER : ( PART.P_PARTKEY ) IN ( $V5.P_PARTKEY )
3  -  HASH SHARD ( # 3 )
      READ COLUMN : PART.P_PARTKEY, PART.P_NAME, PART.P_BRAND, PART.P_TYPE
      PHYSICAL FILTER : PART.P_NAME = 'Part#5'
5  -  COLUMN : {PART.P_PARTKEY} AS P_PARTKEY
6  -  TARGET : {PART.P_PARTKEY}
7  -  READ COLUMN : NOTHING
<<< end print plan

```

## Using ROWNUM

The generated query can not include a non-deterministic statement, so it can not include rownum. When rownum is used, it configures COUNT plan node. In conclusion, the cluster puller can not be configured on the top of COUNT plan.

The following is an example of the generated query of when rownum is used.

```

gSQL> \EXPLAIN PLAN
      SELECT rownum, p_name, p_brand, p_type, cluster_group_id
      FROM part;
ROWNUM P_NAME P_BRAND P_TYPE CLUSTER_GROUP_ID
-----
1 Part#3 Brand#2 STEEL 1
2 Part#1 Brand#1 COPPER 3
3 Part#4 Brand#3 NICKEL 3
4 Part#2 Brand#1 NICKEL 2
5 Part#5 Brand#3 STEEL 2
5 rows selected.
>>> start print plan
< Execution Plan >
=====
|  IDX  |  NODE DESCRIPTION  |  ROWS  |
-----
0	SELECT STATEMENT	5	
1	QUERY BLOCK ("$_QB_IDX_2")	5	
2	COUNT	5	
3	PLAN BASED CLUSTER	LOCAL/REMOTE	5
4	TABLE ACCESS ("PART")	1	
=====
1  -  TARGET : ROWNUM, PART.P_NAME, PART.P_BRAND, PART.P_TYPE, PART.CLUSTER_GROUP_ID
3  -  SQL : SELECT /*+ FULL( _A1 ) */ "_A1"."CLUSTER_GROUP_ID", "_A1"."P_NAME",
      "_A1"."P_BRAND", "_A1"."P_TYPE" FROM "PUBLIC"."PART"@LOCAL AS "_A1"

```



```

        TARGET DOMAIN : G1(G1N1,G1N2) 1 rows, G2(G2N1,G2N2) 2 rows, G3(G3N1,G3N2) 2 rows
4 - HASH SHARD ( # 3 )
        READ COLUMN : PART.P_NAME, PART.P_BRAND, PART.P_TYPE
<<< end print plan

```

The following is an example of the generated query of when rownum filter is used.

```

gSQL> \EXPLAIN PLAN
        SELECT p_name, p_brand, p_type, cluster_group_id
        FROM part
        WHERE rownum < 3;
P_NAME P_BRAND   P_TYPE CLUSTER_GROUP_ID
-----
Part#3 Brand#2   STEEL          1
Part#1 Brand#1   COPPER         3
2 rows selected.
>>> start print plan
< Execution Plan >
=====
|  IDX  |  NODE DESCRIPTION          |          ROWS |
=====
|   0   |  SELECT STATEMENT          |              2 |
|   1   |  QUERY BLOCK (" $QB_IDX_2") |              2 |
|   2   |      COUNT                  |              2 |
|   3   |      PLAN BASED CLUSTER    | LOCAL/REMOTE  3 |
|   4   |      TABLE ACCESS ("PART") |              1 |
=====
1 - TARGET : PART.P_NAME, PART.P_BRAND, PART.P_TYPE, PART.CLUSTER_GROUP_ID
2 - STOP KEY FILTER : ROWNUM < 3
3 - SQL : SELECT /*+ FULL( _A1 ) */ "_A1"."CLUSTER_GROUP_ID", "_A1"."P_NAME",
"_A1"."P_BRAND", "_A1"."P_TYPE" FROM "PUBLIC"."PART"@LOCAL AS "_A1"
        TARGET DOMAIN : G1(G1N1,G1N2) 1 rows, G2(G2N1,G2N2) 0 rows, G3(G3N1,G3N2) 2 rows
4 - HASH SHARD ( # 3 )
        READ COLUMN : PART.P_NAME, PART.P_BRAND, PART.P_TYPE
<<< end print plan

```

## GROUP BY Statement

The query process for the group by statement varies upon the sharding strategy which can be used by the subordinate plan node, and grouping configuration.

**Table 12-12** Grouping according to the sharding strategy of subordinate node

| Sharding strategy of subordinate node, and grouping                         | Data collection                                                                        | Data manipulation | Processing <i>having</i> clause                              |
|-----------------------------------------------------------------------------|----------------------------------------------------------------------------------------|-------------------|--------------------------------------------------------------|
| When all sharding keys of subordinate node are included in the grouping key | It performs the generated query including <i>group by</i> statement in all groups.     | no manipulation   | It includes <i>having</i> clause in the generated query.     |
| When subordinate node is a cloned node                                      | It performs the generated query including <i>group by</i> statement in a single group. | no manipulation   | It includes <i>having</i> clause in the generated query.     |
| When it is unable to use the sharding strategy of the subordinate node      | It performs the generated query excluding <i>group by</i> statement in all groups.     | grouping          | It applies <i>having</i> clause after manipulating the data. |



If having clause includes the non-deterministic information, except when the subordinate node is a cloned node, then the generated query including grouping can not be configured. In conclusion, the cluster puller plan node is configured below *group by*.

The following is an example of grouping when all sharding keys on the subordinate node are included in the grouping key.

```
gSQL> \EXPLAIN PLAN
      SELECT p_partkey
      FROM part
      GROUP BY p_partkey
      HAVING SUM( p_size ) > 0;
P_PARTKEY
-----
      3
      1
      4
      2
      5
5 rows selected.
>>> start print plan
< Execution Plan >
=====
|  IDX  |  NODE DESCRIPTION  |  ROWS  | |
|---|---|---|---|
|   0   |  SELECT STATEMENT  |        |
|   1   |  QUERY BLOCK ("QB_IDX_2") |        |
|   2   |  PLAN BASED CLUSTER | LOCAL/REMOTE | 5 |
```

```

| 3 |          GROUP HASH INSTANT          |          1 |
| 4 |          TABLE ACCESS ("PART")      |          1 |
=====
1 - TARGET : PART.P_PARTKEY
2 - SQL : SELECT /*+ USE_GROUP_HASH(500) FULL( _A1 ) */ "_A1".P_PARTKEY FROM
"PUBLIC"."PART"@LOCAL AS "_A1" GROUP BY "_A1".P_PARTKEY HAVING SUM( "_A1".P_SIZE ) > :_V0
TARGET DOMAIN : G1(G1N1,G1N2) 1 rows, G2(G2N1,G2N2) 2 rows, G3(G3N1,G3N2) 2 rows
3 - GROUP KEY : PART.P_PARTKEY
RECORD COLUMN : SUM( PART.P_SIZE )
READ KEY COLUMN : PART.P_PARTKEY
READ RECORD COLUMN : SUM( PART.P_SIZE )
PHYSICAL FILTER : SUM( PART.P_SIZE ) > 0
4 - HASH SHARD ( # 3 )
READ COLUMN : PART.P_PARTKEY, PART.P_SIZE
<<< end print plan

```

The following is an example of grouping when the subordinate node is a cloned node.

```

gSQL> \EXPLAIN PLAN
SELECT s_nationkey
FROM supplier
GROUP BY s_nationkey
HAVING COUNT( DISTINCT s_name ) > 0;
S_NATIONKEY
-----
CANADA
UNITED STATES
GERMANY
KOREA
FRANCE
5 rows selected.
>>> start print plan
< Execution Plan >
=====
|  IDX  |  NODE DESCRIPTION          |          ROWS |
-----|-----|-----|
|  0  |  SELECT STATEMENT          |          5 |
|  1  |  QUERY BLOCK ("$_QB_IDX_2") |          5 |
|  2  |  GROUP HASH INSTANT        |          5 |
|  3  |  TABLE ACCESS ("SUPPLIER") |          5 |
=====

```

```

1 - TARGET : SUPPLIER.S_NATIONKEY
2 - GROUP KEY : SUPPLIER.S_NATIONKEY
   RECORD COLUMN : COUNT( DISTINCT SUPPLIER.S_NAME )
   READ KEY COLUMN : SUPPLIER.S_NATIONKEY
   READ RECORD COLUMN : COUNT( DISTINCT SUPPLIER.S_NAME )
   PHYSICAL FILTER : COUNT( DISTINCT SUPPLIER.S_NAME ) > 0
3 - CLONED
   READ COLUMN : SUPPLIER.S_NAME, SUPPLIER.S_NATIONKEY

```

```
<<< end print plan
```

In the result above, it accessed only to a local server (a single group) when grouping the cloned table. The following is an example of grouping when it is required to access the data in the remote server.

```

gSQL> \EXPLAIN PLAN
      SELECT s_nationkey
      FROM supplier@g2
      GROUP BY s_nationkey
      HAVING COUNT( DISTINCT s_name ) > 0;

```

```
S_NATIONKEY
-----
```

```
CANADA
```

```
UNITED STATES
```

```
GERMANY
```

```
KOREA
```

```
FRANCE
```

```
5 rows selected.
```

```
>>> start print plan
```

```
< Execution Plan >
```

```

=====
IDX	NODE DESCRIPTION	ROWS	
0	SELECT STATEMENT	5	
1	QUERY BLOCK ("$_QB_IDX_2")	5	
2	PLAN BASED CLUSTER	REMOTE ONLY	5
3	GROUP HASH INSTANT	0	
4	TABLE ACCESS ("SUPPLIER")	0	
=====

```

```

1 - TARGET : SUPPLIER.S_NATIONKEY
2 - SQL : SELECT /*+ USE_GROUP_HASH(10) FULL( _A1 ) */ "_A1"."S_NATIONKEY" FROM
"PUBLIC"."SUPPLIER"@LOCAL AS "_A1" GROUP BY "_A1"."S_NATIONKEY" HAVING COUNT( DISTINCT
"_A1"."S_NAME" ) > :_V0

```

```

    TARGET DOMAIN : G2(G2N1,G2N2) 5 rows, G3(G3N1,G3N2) 0 rows
3 - GROUP KEY : SUPPLIER.S_NATIONKEY
    RECORD COLUMN : COUNT( DISTINCT SUPPLIER.S_NAME )
    READ KEY COLUMN : SUPPLIER.S_NATIONKEY
    READ RECORD COLUMN : COUNT( DISTINCT SUPPLIER.S_NAME )
    PHYSICAL FILTER : COUNT( DISTINCT SUPPLIER.S_NAME ) > 0
4 - CLONED
    READ COLUMN : SUPPLIER.S_NAME, SUPPLIER.S_NATIONKEY

```

```
<<< end print plan
```

When sharding strategy of the subordinate node is unable to use for grouping, it performs the grouping per group through the generated query. It collects the data, then performs the grouping again to create the grouping result. The generated query configured at that moment does not include *having* clause. *having* clause is evaluated after creating the grouping result.

The following is an example of grouping which can not use the sharding strategy of the subordinate node.

```

gSQL> \EXPLAIN PLAN
      SELECT p_type
      FROM part
      GROUP BY p_type
      HAVING SUM( p_size ) > 0;

```

```
P_TYPE
```

```
-----
```

```
STEEL
```

```
NICKEL
```

```
COPPER
```

```
3 rows selected.
```

```
>>> start print plan
```

```
< Execution Plan >
```

```

=====
IDX	NODE DESCRIPTION	ROWS
0	SELECT STATEMENT	3
1	QUERY BLOCK ("QB_IDX_2")	3
2	SINGLE CLUSTER	LOCAL/REMOTE 3
3	SELECT STATEMENT	1
4	QUERY BLOCK ("QB_IDX_2")	1
5	GROUP HASH INSTANT	1
6	TABLE ACCESS ("PART" AS _A1)	1
=====

```

```

1 - TARGET : PART.P_TYPE
2 - SQL : SELECT /*+ USE_GROUP_HASH(10) FULL( _A1 ) */ "_A1"."P_TYPE", SUM(
"_A1"."P_SIZE" ) FROM "PUBLIC"."PART"@LOCAL AS "_A1" GROUP BY "_A1"."P_TYPE"
TARGET DOMAIN : G1(G1N1,G1N2) 1 rows, G2(G2N1,G2N2) 2 rows, G3(G3N1,G3N2) 2 rows
RE-GROUPING
GROUP KEY : PART.P_TYPE
AGGREGATION : SUM( SUM( PART.P_SIZE ) )
PHYSICAL FILTER : SUM( PART.P_SIZE ) > 0
4 - TARGET : _A1.P_TYPE, SUM( _A1.P_SIZE )
5 - GROUP KEY : _A1.P_TYPE
RECORD COLUMN : SUM( _A1.P_SIZE )
READ KEY COLUMN : _A1.P_TYPE
READ RECORD COLUMN : SUM( _A1.P_SIZE )
6 - HASH SHARD ( # 3 )
READ COLUMN : _A1.P_TYPE, _A1.P_SIZE
<<< end print plan

```

In the result above, it collects the data by using the single cluster, then performs grouping.

When sharding strategy of the subordinate node is unable to use for grouping, it can be processed by using ordering for the grouping key in the generated query. The data collected by processing the generated query from each group is sorted per grouping key by merge sorting. Then, it performs the grouping again based on the sorted data, and it is called as merge-grouping.

The following is an example of grouping by using the merge-grouping.

```

gSQL> \EXPLAIN PLAN
SELECT /*+ MERGE_GROUP */ p_brand
FROM part
GROUP BY p_brand
HAVING SUM( p_size ) > 0;
P_BRAND
-----
Brand#1
Brand#2
Brand#3
3 rows selected.
>>> start print plan
< Execution Plan >
=====
| IDX | NODE DESCRIPTION |          ROWS |
-----

```

```

0	SELECT STATEMENT	3	
1	QUERY BLOCK (" $QB_IDX_2")	3	
2	MULTIPLE CLUSTER	LOCAL/REMOTE 3	
3	SELECT STATEMENT	1	
4	QUERY BLOCK (" $QB_IDX_2")	1	
5	GROUP	1	
6	INDEX ACCESS ("PART" AS _A1, "IDX_P_BRAND")	( 1)	1
=====
1 - TARGET : PART.P_BRAND
2 - SQL : SELECT /*+ INDEX( _A1, "PUBLIC"."IDX_P_BRAND" ) */ "_A1".P_BRAND, SUM(
"_A1".P_SIZE ) FROM "PUBLIC"."PART"@LOCAL AS "_A1" GROUP BY "_A1".P_BRAND ORDER BY
"_A1".P_BRAND ASC NULLS LAST
TARGET DOMAIN : G1(G1N1,G1N2) 1 rows, G2(G2N1,G2N2) 2 rows, G3(G3N1,G3N2) 2 rows
MERGE GROUPING
SORT KEY : PART.P_BRAND
GROUP KEY : PART.P_BRAND
AGGREGATION : SUM( SUM( PART.P_SIZE ) )
LOGICAL FILTER : SUM( PART.P_SIZE ) > 0
4 - TARGET : _A1.P_BRAND, SUM( _A1.P_SIZE )
5 - GROUP KEY : _A1.P_BRAND
RECORD COLUMN : SUM( _A1.P_SIZE )
6 - HASH SHARD ( # 3 )
READ INDEX COLUMN : _A1.P_BRAND
READ TABLE COLUMN : _A1.P_SIZE
<<< end print plan

```

## ORDER BY Statement

The cluster puller uses merge sorting to manipulate the data for *order by* statement. It configures the generated query including ordering, then collects the data per group. It merges the data while sorting the collected data in an order of the ordering key. *Order by* node can not have a filter, so it transfers the merge sorting result to the superordinate node without modification.

It uses multiple clusters to perform merge sorting.

The following is an example of processing *order by* statement for the sharded table by using merge sorting.

```

gSQL> \EXPLAIN PLAN
      SELECT p_type
      FROM part
      ORDER BY p_size;
P_TYPE

```

```

-----
NICKEL
COPPER
NICKEL
STEEL
STEEL
5 rows selected.
>>> start print plan
< Execution Plan >
=====
|  IDX  |  NODE DESCRIPTION                               |          ROWS |
-----|-----|-----|
|   0   |  SELECT STATEMENT                               |              5 |
|   1   |    QUERY BLOCK ("$_QB_IDX_2")                   |              5 |
|   2   |      MULTIPLE CLUSTER                           | LOCAL/REMOTE  5 |
|   3   |        SELECT STATEMENT                         |              1 |
|   4   |          QUERY BLOCK ("$_QB_IDX_2")              |              1 |
|   5   |            SORT INSTANT                          |              1 |
|   6   |              TABLE ACCESS ("PART" AS _A1)      |              1 |
=====
1 - TARGET : PART.P_SIZE
2 - SQL : SELECT /*+ USE_ORDER_SORT FULL( _A1 ) */ "_A1"."P_SIZE", "_A1"."P_TYPE" FROM
"PUBLIC"."PART"@LOCAL AS "_A1" ORDER BY "_A1"."P_SIZE" ASC NULLS LAST
TARGET DOMAIN : G1(G1N1,G1N2) 1 rows, G2(G2N1,G2N2) 2 rows, G3(G3N1,G3N2) 2 rows
MERGE SORTING
SORT KEY : PART.P_SIZE
4 - TARGET : _A1.P_SIZE, _A1.P_TYPE
5 - SORT KEY : "_A1.P_SIZE ASC NULLS LAST"
RECORD COLUMN : _A1.P_TYPE
READ KEY COLUMN : _A1.P_SIZE
READ RECORD COLUMN : _A1.P_TYPE
6 - HASH SHARD ( # 3 )
READ COLUMN : _A1.P_TYPE, _A1.P_SIZE
<<< end print plan

```

If non-deterministic information is included in the ordering key, then the generated query can not include the ordering information. In this case, the cluster puller plan node is configured below the *order by* node.

The following is an example of an ordering including the non-deterministic information.



```

gSQL> \EXPLAIN PLAN
      SELECT p_type
      FROM part
      ORDER BY p_size, RANDOM( 1, 1 );
P_TYPE
-----
NICKEL
COPPER
NICKEL
STEEL
STEEL
5 rows selected.
>>> start print plan
< Execution Plan >
=====
|  IDX  |  NODE DESCRIPTION          |  ROWS  |
-----|-----|-----|
|   0   |  SELECT STATEMENT          |        |
|   1   |  QUERY BLOCK ("QB_IDX_2")  |        |
|   2   |  SORT INSTANT              |        |
|   3   |  PLAN BASED CLUSTER        | LOCAL/REMOTE |
|   4   |  TABLE ACCESS ("PART")    |        |
=====
1 - TARGET : PART.P_TYPE
2 - SORT KEY : "PART.P_SIZE ASC NULLS LAST", "RANDOM(1,1) ASC NULLS LAST"
   RECORD COLUMN : PART.P_TYPE
   READ RECORD COLUMN : PART.P_TYPE
3 - SQL : SELECT /*+ FULL( _A1 ) */ "_A1"."P_TYPE", "_A1"."P_SIZE" FROM
"PUBLIC"."PART"@LOCAL AS "_A1"
   TARGET DOMAIN : G1(G1N1,G1N2) 1 rows, G2(G2N1,G2N2) 2 rows, G3(G3N1,G3N2) 2 rows
4 - HASH SHARD ( # 3 )
   READ COLUMN : PART.P_TYPE, PART.P_SIZE
<<< end print plan

```

*order by* statement and *group by* statement can be processed by using a single cluster puller in the following cases.

- When all ordering keys are included in the grouping key
- When the subordinate node of grouping is a cloned node
- When all sharding keys on the subordinate node of grouping are used as a grouping key

The following is an example of when all ordering keys are included in the grouping key.

```

gSQL> \EXPLAIN PLAN
      SELECT p_partkey, COUNT( p_type )
      FROM part
      GROUP BY p_partkey
      ORDER BY p_partkey;

```

```

P_PARTKEY COUNT( P_TYPE )

```

```

-----
      1          1
      2          1
      3          1
      4          1
      5          1

```

5 rows selected.

```
>>> start print plan
```

```
< Execution Plan >
```

```

=====
|  IDX  |  NODE DESCRIPTION  |  ROWS  |
-----
0	SELECT STATEMENT	5
1	QUERY BLOCK ("QB_IDX_2")	5
2	MULTIPLE CLUSTER	LOCAL/REMOTE 5
3	SELECT STATEMENT	1
4	QUERY BLOCK ("QB_IDX_2")	1
5	SORT INSTANT	1
6	GROUP HASH INSTANT	1
7	TABLE ACCESS ("PART" AS _A1)	1
=====

```

```

1 - TARGET : PART.P_PARTKEY, COUNT( PART.P_TYPE )
2 - SQL : SELECT /*+ USE_ORDER_SORT USE_GROUP_HASH(500) FULL( _A1 ) */
_A1". "P_PARTKEY", COUNT( "_A1". "P_TYPE" ) FROM "PUBLIC"."PART"@LOCAL AS "_A1" GROUP BY
"_A1". "P_PARTKEY" ORDER BY "_A1". "P_PARTKEY" ASC NULLS LAST
      TARGET DOMAIN : G1(G1N1,G1N2) 1 rows, G2(G2N1,G2N2) 2 rows, G3(G3N1,G3N2) 2 rows
MERGE SORTING
      SORT KEY : PART.P_PARTKEY
4 - TARGET : _A1.P_PARTKEY, COUNT( _A1.P_TYPE )
5 - SORT KEY : "_A1.P_PARTKEY ASC NULLS LAST"
      RECORD COLUMN : COUNT( _A1.P_TYPE )
      READ KEY COLUMN : _A1.P_PARTKEY
      READ RECORD COLUMN : COUNT( _A1.P_TYPE )
6 - GROUP KEY : _A1.P_PARTKEY
      RECORD COLUMN : COUNT( _A1.P_TYPE )

```

```

        READ KEY COLUMN : _A1.P_PARTKEY
        READ RECORD COLUMN : COUNT( _A1.P_TYPE )
7 - HASH SHARD ( # 3 )
        READ COLUMN : _A1.P_PARTKEY, _A1.P_TYPE
<<< end print plan

```

The following is an example of ordering and grouping by using a single cluster puller when the subordinate node of grouping is a cloned node.

```

gSQL> \EXPLAIN PLAN
        SELECT s_nationkey, COUNT( s_suppkey )
          FROM supplier@G2|G3
        GROUP BY s_nationkey
        ORDER BY COUNT( s_suppkey );
S_NATIONKEY      COUNT( S_SUPPKEY )
-----
CANADA                      1
UNITED STATES                1
GERMANY                      1
KOREA                        1
FRANCE                       1
5 rows selected.
>>> start print plan
< Execution Plan >
=====
|  IDX  |  NODE DESCRIPTION                               |  ROWS  |
-----
0	SELECT STATEMENT	5
1	QUERY BLOCK ("SQB_IDX_2")	5
2	PLAN BASED CLUSTER	REMOTE ONLY 5
3	SORT INSTANT	0
4	GROUP HASH INSTANT	0
5	TABLE ACCESS ("SUPPLIER")	0
=====
1 - TARGET : SUPPLIER.S_NATIONKEY, COUNT( SUPPLIER.S_SUPPKEY )
2 - SQL : SELECT /*+ USE_ORDER_SORT USE_GROUP_HASH(10) FULL( _A1 ) */ COUNT(
"_A1"."S_SUPPKEY" ), "_A1"."S_NATIONKEY" FROM "PUBLIC"."SUPPLIER"@LOCAL AS "_A1" GROUP BY
"_A1"."S_NATIONKEY" ORDER BY COUNT( "_A1"."S_SUPPKEY" ) ASC NULLS LAST
        TARGET DOMAIN : G2(G2N1,G2N2) 5 rows, G3(G3N1,G3N2) 0 rows
3 - SORT KEY : "COUNT( SUPPLIER.S_SUPPKEY ) ASC NULLS LAST"
        RECORD COLUMN : SUPPLIER.S_NATIONKEY

```

```

        READ KEY COLUMN : COUNT( SUPPLIER.S_SUPPKEY )
        READ RECORD COLUMN : SUPPLIER.S_NATIONKEY
4 - GROUP KEY : SUPPLIER.S_NATIONKEY
        RECORD COLUMN : COUNT( SUPPLIER.S_SUPPKEY )
        READ KEY COLUMN : SUPPLIER.S_NATIONKEY
        READ RECORD COLUMN : COUNT( SUPPLIER.S_SUPPKEY )
5 - CLONED
        READ COLUMN : SUPPLIER.S_SUPPKEY, SUPPLIER.S_NATIONKEY
<<< end print plan

```

The following is an example of ordering and grouping by using a single cluster puller when all sharding keys on the subordinate node of grouping are used as a grouping key.

```

gSQL> \EXPLAIN PLAN
        SELECT p_partkey, COUNT( p_type )
        FROM part
        GROUP BY p_partkey
        ORDER BY COUNT( p_type );
P_PARTKEY COUNT( P_TYPE )
-----
      3          1
      2          1
      5          1
      1          1
      4          1

5 rows selected.
>>> start print plan
< Execution Plan >
=====
|  IDX  |  NODE DESCRIPTION  |  ROWS  |
-----
0	SELECT STATEMENT	5
1	QUERY BLOCK ("QB_IDX_2")	5
2	MULTIPLE CLUSTER	LOCAL/REMOTE 5
3	SELECT STATEMENT	1
4	QUERY BLOCK ("QB_IDX_2")	1
5	SORT INSTANT	1
6	GROUP HASH INSTANT	1
7	TABLE ACCESS ("PART" AS _A1)	1
=====
1 - TARGET : PART.P_PARTKEY, COUNT( PART.P_TYPE )

```

```

2 - SQL : SELECT /*+ USE_ORDER_SORT USE_GROUP_HASH(500) FULL( _A1 ) */ COUNT(
"_A1"."P_TYPE" ), "_A1"."P_PARTKEY" FROM "PUBLIC"."PART"@LOCAL AS "_A1" GROUP BY
"_A1"."P_PARTKEY" ORDER BY COUNT( "_A1"."P_TYPE" ) ASC NULLS LAST
    TARGET DOMAIN : G1(G1N1,G1N2) 1 rows, G2(G2N1,G2N2) 2 rows, G3(G3N1,G3N2) 2 rows
    MERGE SORTING
    SORT KEY : COUNT( PART.P_TYPE )
4 - TARGET : COUNT( _A1.P_TYPE ), _A1.P_PARTKEY
5 - SORT KEY : "COUNT( _A1.P_TYPE ) ASC NULLS LAST"
    RECORD COLUMN : _A1.P_PARTKEY
    READ KEY COLUMN : COUNT( _A1.P_TYPE )
    READ RECORD COLUMN : _A1.P_PARTKEY
6 - GROUP KEY : _A1.P_PARTKEY
    RECORD COLUMN : COUNT( _A1.P_TYPE )
    READ KEY COLUMN : _A1.P_PARTKEY
    READ RECORD COLUMN : COUNT( _A1.P_TYPE )
7 - HASH SHARD ( # 3 )
    READ COLUMN : _A1.P_PARTKEY, _A1.P_TYPE
<<< end print plan

```

## DISTINCT Statement

The generated query of the cluster puller to perform distinct statement includes distinct statement. When performing distinct for the sharded table, then it collects the data and configures the result through grouping. Performing distinct for a cloned table configures the result without modifying the collected data.

The following is an example of processing distinct statement for the sharded table.

```

gSQL> \EXPLAIN PLAN
    SELECT DISTINCT p_name
    FROM part;
P_NAME
-----
Part#2
Part#4
Part#3
Part#1
Part#5
5 rows selected.
>>> start print plan
< Execution Plan >
=====
|  IDX  |  NODE DESCRIPTION  |  ROWS  |

```

```

-----
0	SELECT STATEMENT	5	
1	QUERY BLOCK ("$_QB_IDX_2")	5	
2	SINGLE CLUSTER	LOCAL/REMOTE	5
3	SELECT STATEMENT	1	
4	QUERY BLOCK ("$_QB_IDX_2")	1	
5	GROUP HASH INSTANT	1	
6	TABLE ACCESS ("PART" AS _A1)	1	
=====
1 - TARGET : PART.P_NAME
2 - SQL : SELECT /*+ USE_DISTINCT_HASH(10) FULL( _A1 ) */ DISTINCT "_A1"."P_NAME" FROM
"PUBLIC"."PART"@LOCAL AS "_A1"
   TARGET DOMAIN : G1(G1N1,G1N2) 1 rows, G2(G2N1,G2N2) 2 rows, G3(G3N1,G3N2) 2 rows
   RE-GROUPING
   GROUP KEY : PART.P_NAME
4 - TARGET : _A1.P_NAME
5 - GROUP KEY : _A1.P_NAME
   READ KEY COLUMN : _A1.P_NAME
6 - HASH SHARD ( # 3 )
   READ COLUMN : _A1.P_NAME
<<< end print plan

```

The following is an example of processing distinct statement for the cloned table in a remote server.

```

gSQL> \EXPLAIN PLAN
      SELECT DISTINCT s_name, s_nationkey
      FROM supplier@G2;
S_NAME          S_NATIONKEY
-----
Supplier#1      FRANCE
Supplier#5      CANADA
Supplier#4      UNITED STATES
Supplier#3      GERMANY
Supplier#2      KOREA
5 rows selected.
>>> start print plan
< Execution Plan >
=====
|  IDX | NODE DESCRIPTION | ROWS |
-----
|  0 | SELECT STATEMENT | 5 |

```

```

1	QUERY BLOCK ("$_QB_IDX_2")	5	
2	PLAN BASED CLUSTER	REMOTE ONLY	5
3	GROUP HASH INSTANT	0	
4	TABLE ACCESS ("SUPPLIER")	0	
=====
1 - TARGET : SUPPLIER.S_NAME, SUPPLIER.S_NATIONKEY
2 - SQL : SELECT /*+ USE_DISTINCT_HASH(100) FULL( _A1 ) */ DISTINCT "_A1". "S_NAME",
"_A1". "S_NATIONKEY" FROM "PUBLIC"."SUPPLIER"@LOCAL AS "_A1"
   TARGET DOMAIN : G2(G2N1,G2N2) 5 rows
3 - GROUP KEY : SUPPLIER.S_NAME, SUPPLIER.S_NATIONKEY
   READ KEY COLUMN : SUPPLIER.S_NAME, SUPPLIER.S_NATIONKEY
4 - CLONED
   READ COLUMN : SUPPLIER.S_NAME, SUPPLIER.S_NATIONKEY
<<< end print plan

```

## Single Row Statement

Single row query processing in cluster is classified according to whether it is a cloned table or a sharded table. The generated query for process the single row query for the cloned table includes all aggregation functions. It configures the result by collecting the data performed the generated query only in a single group.

The following is an example of a single row statement for the cloned table in a remote server.

```

gSQL> \EXPLAIN PLAN
      SELECT COUNT( DISTINCT s_name ), SUM( s_suppkey )
      FROM supplier@G2;
COUNT( DISTINCT S_NAME ) SUM( S_SUPPKEY )
-----
                    5          15

1 row selected.
>>> start print plan
< Execution Plan >
=====
|  IDX |  NODE DESCRIPTION |  ROWS | |
|---|---|---|---|
|  0  |  SELECT STATEMENT |      1 |
|  1  |  QUERY BLOCK ("$_QB_IDX_2") |      1 |
|  2  |  PLAN BASED CLUSTER | REMOTE ONLY |      1 |
|  3  |  AGGREGATION BY HASH |      0 |
|  4  |  TABLE ACCESS ("SUPPLIER") |      0 |
=====

```

```

1 - TARGET : COUNT( DISTINCT SUPPLIER.S_NAME ), SUM( SUPPLIER.S_SUPPKEY )
2 - SQL : SELECT /*+ FULL( _A1 ) */ COUNT( DISTINCT "_A1"."S_NAME" ), SUM(
"_A1"."S_SUPPKEY" ) FROM "PUBLIC"."SUPPLIER"@LOCAL AS "_A1"
TARGET DOMAIN : G2(G2N1,G2N2) 1 rows
3 - AGGREGATION : SUM( SUPPLIER.S_SUPPKEY )
DISTINCT AGGREGATION : COUNT( DISTINCT SUPPLIER.S_NAME )
4 - CLONED
READ COLUMN : SUPPLIER.S_SUPPKEY, SUPPLIER.S_NAME
<<< end print plan

```

Single row query processing in a sharded table is classified according to whether the aggregation function includes distinct or not.

When one or more aggregation functions including distinct exist.

- The cluster puller plan node is configured below the plan for a single row processing.
- The generated query does not include an aggregation function.

The following is an example of processing a single row for a sharded table which has an aggregation including distinct.

```

gSQL> \EXPLAIN PLAN
      SELECT COUNT( DISTINCT p_name ), SUM( p_size )
      FROM part;
COUNT( DISTINCT P_NAME ) SUM( P_SIZE )
-----
                    5          58

1 row selected.
>>> start print plan
< Execution Plan >
=====
|  IDX  |  NODE DESCRIPTION          |          ROWS |
-----|-----|-----|
|   0   |  SELECT STATEMENT          |               1 |
|   1   |    QUERY BLOCK ("$_QB_IDX_2") |               1 |
|   2   |      AGGREGATION BY HASH    |               1 |
|   3   |      PLAN BASED CLUSTER    | LOCAL/REMOTE  5 |
|   4   |        TABLE ACCESS ("PART") |               1 |
=====
1 - TARGET : COUNT( DISTINCT PART.P_NAME ), SUM( PART.P_SIZE )
2 - AGGREGATION : SUM( PART.P_SIZE )
DISTINCT AGGREGATION : COUNT( DISTINCT PART.P_NAME )

```



```

3 - SQL : SELECT /*+ FULL( _A1 ) */ "_A1"."P_NAME", "_A1"."P_SIZE" FROM
"PUBLIC"."PART"@LOCAL AS "_A1"
      TARGET DOMAIN : G1(G1N1,G1N2) 1 rows, G2(G2N1,G2N2) 2 rows, G3(G3N1,G3N2) 2 rows
4 - HASH SHARD ( # 3 )
      READ COLUMN : PART.P_NAME, PART.P_SIZE
<<< end print plan

```

When all aggregations do not have distinct

- The plan to process a single row is not configured.
- The generated query includes an aggregation function.
- It configures the result by performing an aggregation after collecting the data.

The following is an example of processing a single row for a sharded table which does not have an aggregation including distinct.

```

gSQL> \EXPLAIN PLAN
      SELECT COUNT( p_name ), SUM( p_size )
      FROM part;
COUNT( P_NAME ) SUM( P_SIZE )
-----
           5           58
1 row selected.
>>> start print plan
< Execution Plan >
=====
|  IDX  |  NODE DESCRIPTION  |  ROWS  |
-----
0	SELECT STATEMENT	
1	QUERY BLOCK ("$_QB_IDX_2")	
2	SINGLE CLUSTER	LOCAL/REMOTE
3	SELECT STATEMENT	
4	QUERY BLOCK ("$_QB_IDX_2")	
5	TABLE ACCESS ("PART" AS _A1)	
=====
1 - TARGET : COUNT( PART.P_NAME ), SUM( PART.P_SIZE )
2 - SQL : SELECT /*+ FULL( _A1 ) */ COUNT( "_A1"."P_NAME" ), SUM( "_A1"."P_SIZE" ) FROM
"PUBLIC"."PART"@LOCAL AS "_A1"
      TARGET DOMAIN : G1(G1N1,G1N2) 1 rows, G2(G2N1,G2N2) 1 rows, G3(G3N1,G3N2) 1 rows
RE-AGGREGATION
      AGGREGATION : SUM( COUNT( PART.P_NAME ) ), SUM( SUM( PART.P_SIZE ) )
4 - TARGET : COUNT( _A1.P_NAME ), SUM( _A1.P_SIZE )

```

```
5 - HASH SHARD ( # 3 )  
    READ COLUMN : _A1.P_NAME, _A1.P_SIZE  
    AGGREGATION : COUNT( _A1.P_NAME ), SUM( _A1.P_SIZE )  
<<< end print plan
```

## Processing DML in Cluster

In GOLDILOCKS, a user can perform DML for all cluster members configuring a cluster system.

Data manipulation in cluster environment manipulates the data of the cluster member containing the same data replication same as well.

The following constructed table is used to describe the data manipulation.

```
CREATE TABLE t1( shard_key INTEGER, c1 INTEGER )  
    SHARDING BY RANGE( shard_key )  
    SHARD s1 VALUES LESS THAN ( 200 )      AT CLUSTER GROUP G1,  
    SHARD s2 VALUES LESS THAN ( 400 )      AT CLUSTER GROUP G2,  
    SHARD s3 VALUES LESS THAN ( MAXVALUE ) AT CLUSTER GROUP G3;
```

DML is performed as the figure below in cluster environment.

Figure 9 Processing DML in cluster

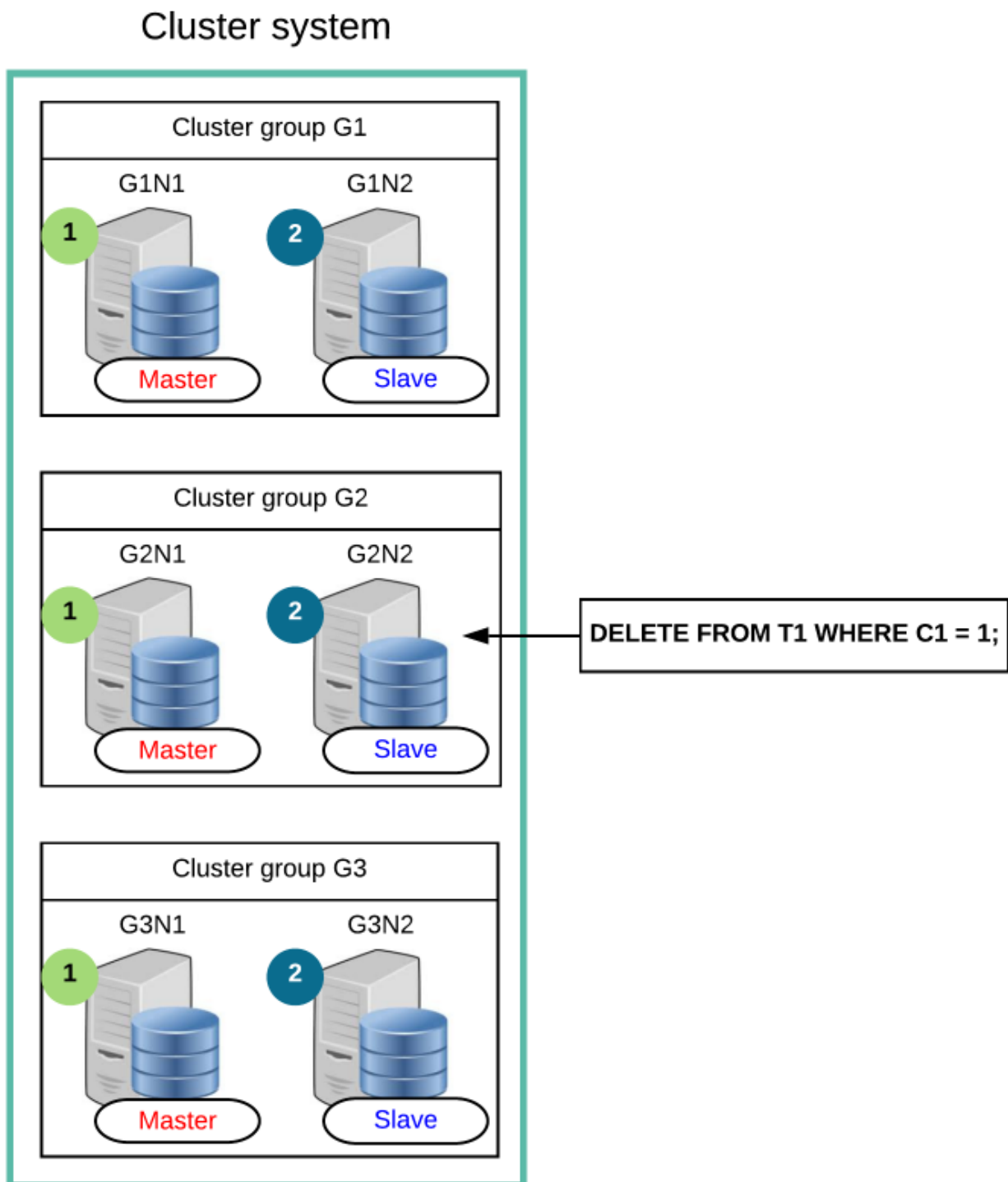

A master server and a slave server per each group are defined for the DML processing in cluster.

## Selecting Master Server in Each Cluster Group

It selects a cluster member which was included first among cluster members accessible from each cluster group when manipulating data in cluster environment.

## Selecting Slave Server in Each Cluster Group

It selects cluster members remained after excluding master servers from accessible cluster members per each cluster group when manipulating data in cluster environment.

Find the information about the master/ slave configuration of each table using the user\_tab\_place view. In the following example, the members for which IS\_UPDATE\_MASTER is TRUE are the master servers of each cluster group.

```
gSQL>
SELECT group_name, member_name, member_position, is_update_master
FROM user_tab_place
WHERE table_name = 'T1';
```

| GROUP_NAME | MEMBER_NAME | MEMBER_POSITION | IS_UPDATE_MASTER |
|------------|-------------|-----------------|------------------|
| G1         | G1N1        | 0               | TRUE             |
| G1         | G1N2        | 1               | FALSE            |
| G2         | G2N1        | 2               | TRUE             |
| G2         | G2N2        | 3               | FALSE            |
| G3         | G3N1        | 4               | TRUE             |
| G3         | G3N2        | 5               | FALSE            |

## Performing DML

DML is sequentially performed by applying to a master server phase then applying to a slave server phase.

- Applying to a master server
  - It manipulates the data in the master server in each cluster group.
- Applying to a slave server
  - It manipulates the data in the slave server in the same way as they were applied in the master server in each cluster group.

In GOLDILOCKS, the following two methods are used to manipulate data while synchronizing the master server and the slave server per each cluster group.

- Query Based DML
- Global Rowid Based DML

## Query Based DML

Query based DML is a method to manipulate records of each server by using the generated query. The generated query is internally generated by a server which was given a query from a user. It is supported only if the same result is guaranteed when performing DML with a generated query from each server.

For more information, refer to **Generated Query**.

The generated query for a master server and the generated query for a slave server may be different each other depending on whether the manipulated record returns the result.

The data manipulation using the generated query is performed as the figure below.

**Figure 10** Updating data using generated query (Altering the entire cluster group target)

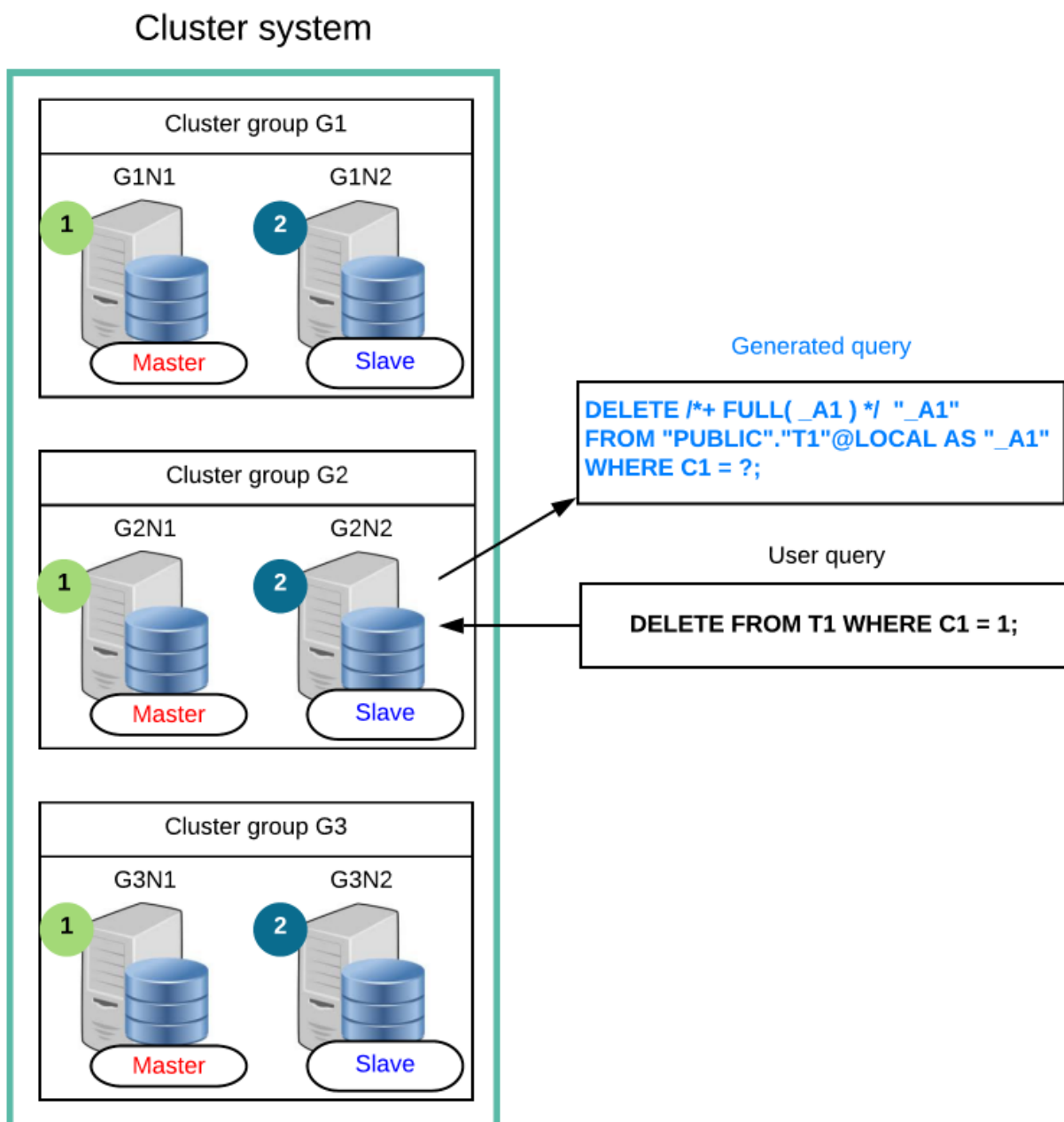

If there is not a condition to select an manipulation target cluster group in a conditional clause as given above, then all cluster groups become the data manipulation target of using the generated query.

The data manipulation using the generated query is performed as follows.

1. The generated query is performed on each master server
2. The generated query is performed on each slave server

If only a specific cluster group is selected as a data manipulation target by a conditional clause, then it is performed as follows.

**Figure 11** Updating data using generated query (Altering a specific cluster group)

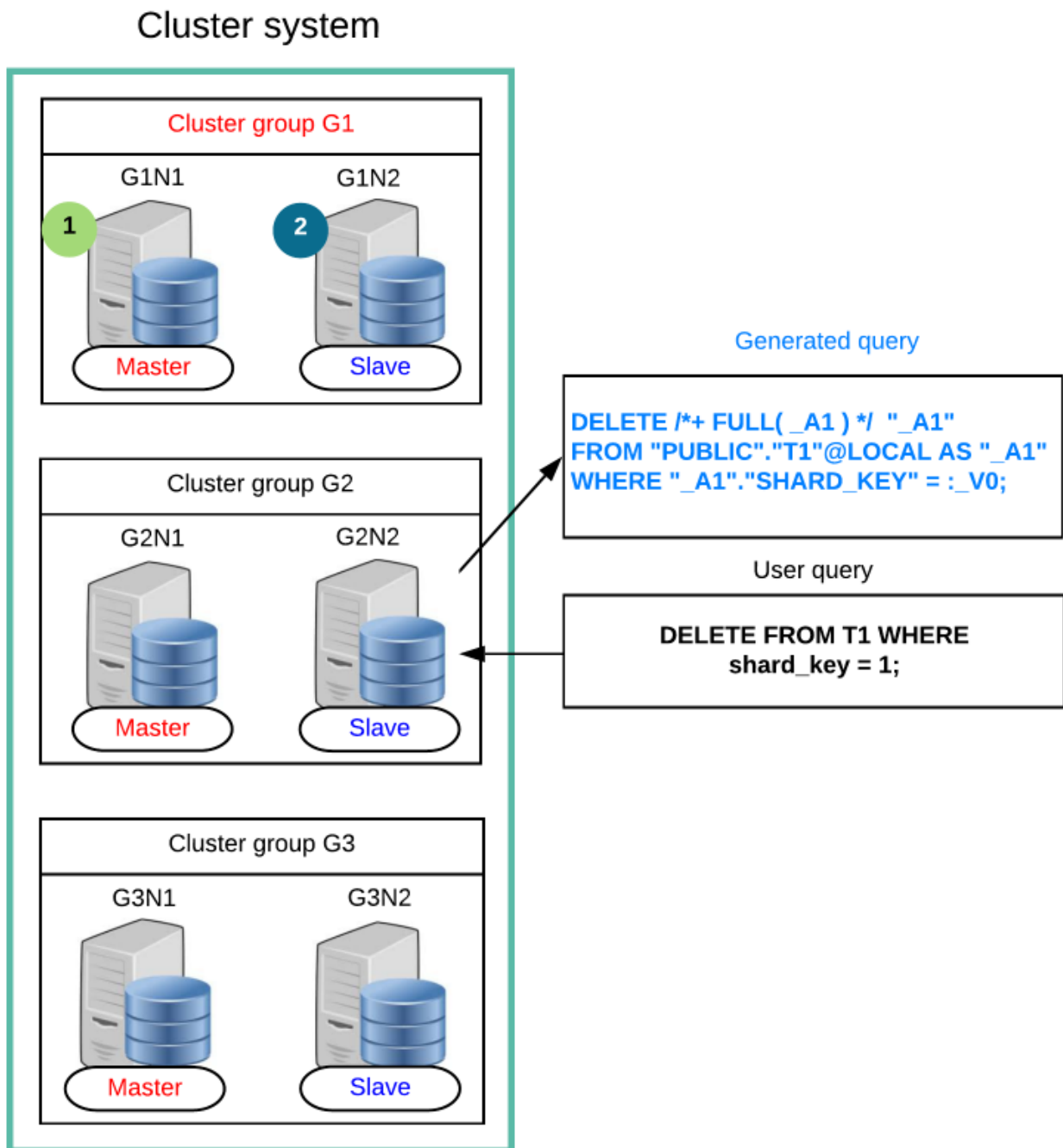

If the manipulation target is determined by using the search condition (`shard_key = 1`) as given above, it is found that the record whose `shard_key` is 1 is in G1 cluster group by the sharding strategy. Therefore, only the record in G1 cluster group is deleted.

Manipulating the data in a specific cluster group is applied to a slave after it is applied to a master as like manipulating the data in the entire cluster group.

The plan node called as DML cluster performs the query based DML. For more information, refer to **DML Cluster**.

Data manipulation using the generated query is supported only in the following cases.

- If the generated query which guarantees the same result when performing the generated query on each cluster member of a cluster group can be generated
  - Refer to **Constraints of Generated Query Configuration**.
- If the data reference target server and the data manipulation target server can be restricted to a same server when configuring the generated query
  - This means that the server performing the generated query does not need to access another server while processing the query.

The following user queries support the data manipulation using the generated query.

- **SELECT .. FOR UPDATE**
- **SELECT .. INTO .. FOR UPDATE**
- **DELETE FROM**
- **DELETE FROM name RETURNING**
- **DELETE FROM name RETURNING .. INTO**
- **UPDATE**
- **UPDATE name RETURNING**
- **UPDATE name RETURNING .. INTO**

The data manipulation using the generated query is available even when the **14.6 Global Secondary Index** is not configured.

## DML Cluster

DML cluster manipulates data from each server by using the generated query, and collects data when it is needed.

The following is an example of processing DELETE RETURN statement for a sharded table with the query based DML.

```
gSQL> \EXPLAIN PLAN DELETE FROM part WHERE p_partkey = 5 RETURN p_name;
P_NAME
-----
```

Part#3

1 row deleted.

&gt;&gt;&gt; start print plan

&lt; Execution Plan &gt;

```

=====
|  IDX  |  NODE DESCRIPTION                               |          ROWS |
=====
0	DELETE STATEMENT ("PART")	1
1	QUERY BLOCK ("$_QB_IDX_2")	0
2	DML CLUSTER	REMOTE ONLY 1
3	INDEX ACCESS ("PART", "PART_PK_INDEX")	(  0)         0
=====

1 - TARGET : PART.P_NAME
2 - FETCH
   Fetch SQL : DELETE /*+ INDEX( _A1, "PUBLIC"."PART_PK_INDEX" ) */ "_A1" FROM
"PUBLIC"."PART"@LOCAL AS "_A1" WHERE "_A1"."P_PARTKEY" = :_V0 RETURN "_A1"."$PHYSICAL_ROWID",
"_A1"."P_PARTKEY", "_A1"."P_NAME", "_A1"."P_BRAND"
   Non-Fetch SQL : DELETE /*+ INDEX( _A1, "PUBLIC"."PART_PK_INDEX" ) */ "_A1" FROM
"PUBLIC"."PART"@LOCAL AS "_A1" WHERE "_A1"."P_PARTKEY" = :_V0
   TARGET DOMAIN : G2(G2N1,G2N2) 1 rows
3 - HASH SHARD ( # 3 )
   READ INDEX COLUMN : PART.P_PARTKEY
   READ TABLE COLUMN : PART.P_NAME, PART.P_BRAND
   MIN RANGE : PART.P_PARTKEY = 5
   MAX RANGE : PART.P_PARTKEY = 5
   FETCH ONE ROW
<<< end print plan

```

DML cluster is used to perform DELETE statement in the query execution result. DML cluster is a plan whose idx of <Execution Plan> is 2 in the execution plan output above.

The detailed information about DML cluster is as follows.

- DML cluster usage type: FETCH, WITHOUT FETCH, SHARD KEY UPDATE
- Fetch SQL: The generated query for performing DML and collecting the data
- Non-fetch SQL: The generated query only for performing DML
- TARGET DOMAIN: The group and member to transfer the generated query and the number of data received from the group
- Shard key update information: The generated query which divided a single UPDATE statement into UPDATE, SELECT, and DELETE

DML cluster usage type is classified according to the user query.



- WITHOUT FETCH: DML which does not acquire the execution result data (DELETE, UPDATE)
- FETCH: DML to acquire the execution result data (SELECT FOR UPDATE, DELETE RETURN, UPDATE RETURN)
- SHARD KEY UPDATE: UPDATE which updates the sharding key (UPDATE, UPDATE RETURN)

### DML Cluster (WITHOUT FETCH)

If DML cluster usage type is WITHOUT FETCH, then the detailed information about DML cluster is configured with non-fetch SQL and TARGET DOMAIN as follows.

```
gSQL> \EXPLAIN PLAN DELETE FROM supplier;
5 rows deleted.
>>> start print plan
< Execution Plan >
=====
|  IDX  |  NODE DESCRIPTION  |  ROWS  |
-----
0	DELETE STATEMENT ("SUPPLIER")	5
1	QUERY BLOCK ("SQB_IDX_2")	0
2	DML CLUSTER	5
3	INDEX ACCESS ("SUPPLIER", ...)	( 5) 5
=====
1 - TARGET : NOTHING
2 - WITHOUT FETCH
   Non-Fetch SQL : DELETE /*+ INDEX( _A1, "PUBLIC"."SUPPLIER_PK_INDEX" ) */ "_A1"
FROM "PUBLIC"."SUPPLIER"@LOCAL AS "_A1"
   TARGET DOMAIN : G1(G1N1,G1N2) 5 rows, G2(G2N1,G2N2) 5 rows, G3(G3N1,G3N2) 5 rows
3 - CLONED
   READ INDEX COLUMN : SUPPLIER.S_SUPPKEY
<<< end print plan
```

If sharded table data manipulation affects only a specific group as follows, then the group in which a non-fetch SQL is performed is restricted.

```
gSQL> \EXPLAIN PLAN DELETE FROM part WHERE p_partkey = 5;
1 row deleted.
>>> start print plan
< Execution Plan >
=====
|  IDX  |  NODE DESCRIPTION  |  ROWS  |
-----
|   0   |  DELETE STATEMENT ("PART")  |        1 |
```

```

1	QUERY BLOCK ("QB_IDX_2")	0
2	DML CLUSTER	1
3	INDEX ACCESS ("PART", "PART_PK_INDEX")	( 0) 0
=====
1 - TARGET : NOTHING
2 - WITHOUT FETCH
   Non-Fetch SQL : DELETE /*+ INDEX( _A1, "PUBLIC"."PART_PK_INDEX" ) */ "_A1" FROM
"PUBLIC"."PART"@LOCAL AS "_A1" WHERE "_A1"."P_PARTKEY" = :_V0
   TARGET DOMAIN : G2(G2N1,G2N2) 1 rows
3 - HASH SHARD ( # 3 )
   READ INDEX COLUMN : PART.P_PARTKEY
   READ TABLE COLUMN : PART.P_BRAND
   MIN RANGE : PART.P_PARTKEY = 5
   MAX RANGE : PART.P_PARTKEY = 5
   FETCH ONE ROW
<<< end print plan

```

A non-fetch SQL of DML cluster which consists of WITHOUT FETCH is performed equally in all master servers and slave servers without distinguishing a cloned table and a sharded table.

### DML Cluster (FETCH)

If DML cluster usage type is FETCH, then the detailed information about DML cluster is configured with fetch SQL, non-fetch SQL and TARGET DOMAIN as follows.

```

gSQL> \EXPLAIN PLAN SELECT p_name FROM part FOR UPDATE;
P_NAME
-----
Part#1
Part#4
Part#3
Part#2
Part#5
5 rows selected.
>>> start print plan
< Execution Plan >
=====
|  IDX  |  NODE DESCRIPTION          |  ROWS  |
-----|-----|-----|
|  0  |  SELECT FOR UPDATE STATEMENT |  5  |
|  1  |  QUERY BLOCK ("QB_IDX_2")   |  0  |
|  2  |  DML CLUSTER                | REMOTE ONLY 5 |

```

```

| 3 | TABLE ACCESS ("PART") | 2 |
=====
1 - TARGET : PART.P_NAME
2 - FETCH
   Fetch SQL : SELECT /*+ FULL( _A1 ) */ "_A1"."$PHYSICAL_ROWID", "_A1"."P_NAME" FROM
"PUBLIC"."PART"@LOCAL AS "_A1" FOR UPDATE OF "_A1"."P_PARTKEY"
   Non-Fetch SQL : SELECT /*+ FULL( _A1 ) */ NULL FROM "PUBLIC"."PART"@LOCAL AS "_A1"
FOR UPDATE OF "_A1"."P_PARTKEY" WITHOUT FETCH
   TARGET DOMAIN : G1(G1N1,G1N2) 2 rows, G2(G2N1,G2N2) 1 rows, G3(G3N1,G3N2) 2 rows
3 - HASH SHARD ( # 3 )
   READ COLUMN : PART.P_NAME
<<< end print plan

```

A non-fetch SQL consists of SELECT FOR UPDATE statement in the result above. The non-fetch SQL configured like this is performed in a local server and a remote server, but it does not collect the data through SELECT FOR UPDATE statement.

The fetch SQL of query based DML for a cloned table is performed on a member among the entire group. If a local server has a replication of a cloned table, then the fetch SQL is performed in a local server. If a local server does not have a replication of a cloned table, then the fetch SQL is performed in an arbitrary server. All servers having a replication of a cloned table except for the server performing fetch SQL performs non-fetch SQLs.

The fetch SQL of query based DML for a sharded table is performed on master servers of each group. All of slave servers perform non-fetch SQL.

If sharded table data manipulation affects only a specific group as follows, then the group in which a fetch SQL and a non-fetch SQL are performed is restricted.

```

gSQL> \EXPLAIN PLAN SELECT p_name FROM part WHERE p_partkey = 5 FOR UPDATE;
P_NAME
-----
Part#3
1 row selected.
>>> start print plan
< Execution Plan >
=====
|  IDX  |  NODE DESCRIPTION                               |  ROWS  |
-----|-----|-----|
|  0  |  SELECT FOR UPDATE STATEMENT                   |        1 |
|  1  |  QUERY BLOCK ("$_QB_IDX_2")                    |         0 |
|  2  |  DML CLUSTER                                | REMOTE ONLY 1 |
|  3  |  INDEX ACCESS ("PART", "PART_PK_INDEX") | ( 0)    0 |

```

```

=====
1 - TARGET : PART.P_NAME
2 - FETCH
   Fetch SQL : SELECT /*+ INDEX( _A1, "PUBLIC"."PART_PK_INDEX" ) */
"_A1"."$PHYSICAL_ROWID", "_A1"."P_NAME" FROM "PUBLIC"."PART"@LOCAL AS "_A1" WHERE
"_A1"."P_PARTKEY" = :_V0 FOR UPDATE OF "_A1"."P_PARTKEY"
   Non-Fetch SQL : SELECT /*+ INDEX( _A1, "PUBLIC"."PART_PK_INDEX" ) */ NULL FROM
"PUBLIC"."PART"@LOCAL AS "_A1" WHERE "_A1"."P_PARTKEY" = :_V0 FOR UPDATE OF "_A1"."P_PARTKEY"
WITHOUT FETCH
      TARGET DOMAIN : G2(G2N1,G2N2) 1 rows
3 - HASH SHARD ( # 3 )
   READ INDEX COLUMN : PART.P_PARTKEY
   READ TABLE COLUMN : PART.P_NAME
      MIN RANGE : PART.P_PARTKEY = 5
      MAX RANGE : PART.P_PARTKEY = 5
      FETCH ONE ROW
<<< end print plan

```

### DML Cluster (SHARD KEY UPDATE)

UPDATE for the sharding key column is classified to the following two types according to whether the shard to which the record belongs is altered before and after the data manipulation.

- In-place update: The shard to which the record belongs is same before and after the data manipulation.
- Out-place update: The shard to which the record belongs is different before and after the data manipulation.

In-place update alters the value without moving the record. The rowid information of the record which were updated through in-place update is not updated.

Out-place update inserts a new record after delete the existing record. New rowid is set in the record which were updated through out-place update.

SHARD KEY UPDATE configures the generated query distinguishing an in-place update and an out-place update.

The generated query for an in-place update consists of UPDATE statement. The generated query has a filter which guarantees that the shards to which the value belongs before and after update are same.

The generated query for an out-place update separately consists of SELECT statement and DELETE statement. Each generated query has a filter which guarantees that the shards to which the value belongs before and after update are different. It configures a new record by collecting data before the update through the generated query consisting of SELECT statement. It inserts new records by using <global rowid based DML>. It deletes all previous records through DELETE statement.

If DML cluster usage type is SHARD KEY UPDATE, then the detailed information about DML cluster is configured with UPDATE SQL for in-place update and SELECT SQL & DELETE SQL for out-place update as follows.

```
gSQL> \EXPLAIN PLAN UPDATE part SET p_partkey = p_partkey + 10;
```

```
5 rows updated.
```

```
>>> start print plan
```

```
< Execution Plan >
```

```
=====
```

| IDX | NODE DESCRIPTION                  | ROWS |
|-----|-----------------------------------|------|
| 0   | UPDATE STATEMENT ("PART")         | 5    |
| 1   | QUERY BLOCK ("QB_IDX_2")          | 0    |
| 2   | <b>DML CLUSTER</b>                | 5    |
| 3   | <b>UPDATE STATEMENT ("PART")</b>  | 0    |
| 4   | QUERY BLOCK ("QB_IDX_2")          | 0    |
| 5   | DML CLUSTER                       | 0    |
| 6   | TABLE ACCESS ("PART" AS _A1)      | 0    |
| 7   | QUERY BLOCK ("QB_IDX_6")          | 0    |
| 8   | INDEX ACCESS ("PART" AS _A1, ...) | 0    |
| 9   | <b>SELECT STATEMENT</b>           | 5    |
| 10  | QUERY BLOCK ("QB_IDX_2")          | 5    |
| 11  | PLAN BASED CLUSTER LOCAL/REMOTE   | 5    |
| 12  | TABLE ACCESS ("PART" AS _A1)      | 2    |
| 13  | <b>DELETE STATEMENT ("PART")</b>  | 5    |
| 14  | QUERY BLOCK ("QB_IDX_2")          | 0    |
| 15  | DML CLUSTER                       | 5    |
| 16  | TABLE ACCESS ("PART" AS _A1)      | 2    |
| 17  | QUERY BLOCK ("QB_IDX_6")          | 0    |
| 18  | TABLE ACCESS ("PART")             | 0    |

```
=====
```

```
1 - TARGET : NOTHING
```

```
2 - SHARD KEY UPDATE
```

```
UPDATE SQL : UPDATE /*+ FULL( _A1 ) */
```

```
"PUBLIC"."PART"@G1N1|G1N2|G2N1|G2N2|G3N1|G3N2 AS "_A1" SET ( "_A1"."P_PARTKEY" ) =
( CAST( "_A1"."P_PARTKEY" + :_V0 AS NUMBER(10, 0) ) ) FROM
```

```
"PUBLIC"."PART"@G1N1|G1N2|G2N1|G2N2|G3N1|G3N2 AS "_A1" WHERE
SHARD_ID("PUBLIC"."PART", "_A1"."P_PARTKEY") = SHARD_ID("PUBLIC"."PART", CAST(
"_A1"."P_PARTKEY" + :_V0 AS NUMBER(10, 0) ))
```

```
SELECT SQL : SELECT /*+ FULL( _A1 ) */ "_A1"."$PHYSICAL_ROWID", "_A1"."P_PARTKEY",
"_A1"."P_NAME", "_A1"."P_BRAND", "_A1"."P_TYPE", "_A1"."P_SIZE", "_A1"."P_RETAILPRICE" FROM
```

```

"PUBLIC"."PART"@G1N1|"G1N2|"G2N1|"G2N2|"G3N1|"G3N2" AS "_A1" WHERE
SHARD_ID("PUBLIC"."PART", "_A1"."P_PARTKEY") <> SHARD_ID("PUBLIC"."PART", CAST(
"_A1"."P_PARTKEY" + :_V0 AS NUMBER(10, 0) ))
    DELETE SQL : DELETE /*+ FULL( _A1 ) */ "_A1" FROM
"PUBLIC"."PART"@G1N1|"G1N2|"G2N1|"G2N2|"G3N1|"G3N2" AS "_A1" WHERE
SHARD_ID("PUBLIC"."PART", "_A1"."P_PARTKEY") <> SHARD_ID("PUBLIC"."PART", CAST(
"_A1"."P_PARTKEY" + :_V0 AS NUMBER(10, 0) ))
    4 - TARGET : NOTHING
    5 - WITHOUT FETCH
        Non-Fetch SQL : UPDATE /*+ FULL( _A1 ) */ "PUBLIC"."PART"@LOCAL AS "_A1" SET (
"_A1"."P_PARTKEY" ) = ( CAST( "_A1"."P_PARTKEY" + :_V0 AS NUMBER(10, 0) ) ) FROM
"PUBLIC"."PART"@LOCAL AS "_A1" WHERE SHARD_ID("PUBLIC"."PART", "_A1"."P_PARTKEY") =
SHARD_ID("PUBLIC"."PART", CAST( "_A1"."P_PARTKEY" + :_V1 AS NUMBER(10, 0) ))
        TARGET DOMAIN : G1(G1N1,G1N2) 0 rows, G2(G2N1,G2N2) 0 rows, G3(G3N1,G3N2) 0 rows
    6 - HASH SHARD ( # 3 )
        READ COLUMN : _A1.P_PARTKEY
        LOGICAL FILTER : SHARD_ID( "PUBLIC"."PART",_A1.P_PARTKEY) = SHARD_ID(
"PUBLIC"."PART",CAST( _A1.P_PARTKEY + :_V0 AS NUMBER(10, 0) ))
    7 - TARGET : NOTHING
    8 - HASH SHARD ( # 3 )
        READ INDEX COLUMN : _A1.P_PARTKEY
    10 - TARGET : _A1.$PHYSICAL_ROWID, _A1.P_PARTKEY, _A1.P_NAME, _A1.P_BRAND, _A1.P_TYPE,
_A1.P_SIZE, _A1.P_RETAILPRICE
    11 - SQL : SELECT /*+ FULL( _A1 ) */ "_A1"."$PHYSICAL_ROWID", "_A1"."P_PARTKEY",
_A1"."P_NAME", "_A1"."P_BRAND", "_A1"."P_TYPE", "_A1"."P_SIZE", "_A1"."P_RETAILPRICE" FROM
"PUBLIC"."PART"@LOCAL AS "_A1" WHERE SHARD_ID("PUBLIC"."PART", "_A1"."P_PARTKEY") <>
SHARD_ID("PUBLIC"."PART",CAST( "_A1"."P_PARTKEY" + :_V0 AS NUMBER(10, 0) ))
        TARGET DOMAIN : G1(G1N1,G1N2) 2 rows, G2(G2N1,G2N2) 1 rows, G3(G3N1,G3N2) 2 rows
    12 - HASH SHARD ( # 3 )
        READ COLUMN : _A1.P_PARTKEY, _A1.P_NAME, _A1.P_BRAND, _A1.P_TYPE, _A1.P_SIZE,
_A1.P_RETAILPRICE
        LOGICAL FILTER : SHARD_ID( "PUBLIC"."PART",_A1.P_PARTKEY) <> SHARD_ID(
"PUBLIC"."PART",CAST( _A1.P_PARTKEY + :_V0 AS NUMBER(10, 0) ))
    14 - TARGET : NOTHING
    15 - WITHOUT FETCH
        Non-Fetch SQL : DELETE /*+ FULL( _A1 ) */ "_A1" FROM "PUBLIC"."PART"@LOCAL AS
_A1" WHERE SHARD_ID("PUBLIC"."PART", "_A1"."P_PARTKEY") <> SHARD_ID("PUBLIC"."PART",CAST(
"_A1"."P_PARTKEY" + :_V0 AS NUMBER(10, 0) ))
        TARGET DOMAIN : G1(G1N1,G1N2) 2 rows, G2(G2N1,G2N2) 1 rows, G3(G3N1,G3N2) 2 rows
    16 - HASH SHARD ( # 3 )
        READ COLUMN : _A1.P_PARTKEY, _A1.P_BRAND

```

```

          LOGICAL FILTER : SHARD_ID( "PUBLIC"."PART",_A1.P_PARTKEY) <> SHARD_ID(
"PUBLIC"."PART",CAST( _A1.P_PARTKEY + :_V0 AS NUMBER(10, 0) ))
    17 - TARGET : NOTHING
    18 - HASH SHARD ( # 3 )
          READ COLUMN : PART.P_PARTKEY, PART.P_NAME, PART.P_BRAND, PART.P_TYPE, PART.P_SIZE,
PART.P_RETAILPRICE
<<< end print plan

```

### Join Operation in DML Cluster

The statement including a subquery can be converted into a join operation by the query processor like as **Join including subquery**. The subquery for DML statement can also be converted to a join operation. DML cluster plan node supports the generated query including a join.

The following is an example of performing DELETE including a subquery.

```

gSQL> \EXPLAIN PLAN
      DELETE FROM part WHERE p_partkey IN ( SELECT ps_partkey FROM partsupp );
3 rows deleted.
>>> start print plan
< Execution Plan >
=====
|  IDX  |  NODE DESCRIPTION                               |          ROWS | |
|---|---|---|---|
|   0   |  DELETE STATEMENT ("PART")                       |              3 |
|   1   |  QUERY BLOCK ("$_QB_IDX_2")                       |              0 |
|   2   |  DML CLUSTER                                     |              3 |
|   3   |  HASH JOIN (SEMI)                                 |              1 |
|   4   |  TABLE ACCESS ("PART")                           |              2 |
|   5   |  HASH JOIN INSTANT (UNIQUE)                       |              1 |
|   6   |  INDEX ACCESS ("PARTSUPP", ...) | ( 2)          |              2 |
=====
    1 - TARGET : NOTHING
    2 - WITHOUT FETCH
          Non-Fetch SQL : DELETE /*+ KEEP_JOINED_TABLE USE_HASH_IN( _A2, 10 ) FULL( _A1 )
INDEX( _A2, "PUBLIC"."PARTSUPP_PK_INDEX" ) */  "_A1" FROM (
"PUBLIC"."PART"@G1N1"|G1N2"|G2N1"|G2N2"|G3N1"|G3N2" AS "_A1" SEMI JOIN
"PUBLIC"."PARTSUPP"@G1N1"|G1N2"|G2N1"|G2N2"|G3N1"|G3N2" AS "_A2" ON "_A2"."PS_PARTKEY" =
"_A1"."P_PARTKEY") ALIAS "_A3"
          TARGET DOMAIN : G1(G1N1,G1N2) 1 rows, G2(G2N1,G2N2) 1 rows, G3(G3N1,G3N2) 1 rows
    3 - JOINED COLUMN : PART.$PHYSICAL_ROWID, PART.P_PARTKEY, PART.P_BRAND
    4 - HASH SHARD ( # 3 )

```

```

        READ COLUMN : PART.P_PARTKEY, PART.P_BRAND
5  -  HASH KEY : PARTSUPP.PS_PARTKEY
        READ KEY COLUMN : PARTSUPP.PS_PARTKEY
        HASH FILTER : PARTSUPP.PS_PARTKEY = PART.P_PARTKEY
        FETCH ONE ROW
6  -  HASH SHARD ( # 3 )
        READ INDEX COLUMN : PARTSUPP.PS_PARTKEY

```

```
<<< end print plan
```

However, DML cluster plan node does not support the manipulating the collected data. The join operation which required the data manipulation after collecting the data through the generated query can not configure DML cluster.

The following is an example of when it converts DML including a subquery to a join operation, but can not configure DML cluster.

```
gSQL> \EXPLAIN PLAN
```

```
DELETE FROM supplier WHERE s_suppkey IN ( SELECT ps_partkey FROM partsupp );
```

```
5 rows deleted.
```

```
>>> start print plan
```

```
< Execution Plan >
```

```

=====
|IDX|  NODE DESCRIPTION                               |          ROWS |
=====
0	DELETE STATEMENT ("SUPPLIER")	5	
1	QUERY BLOCK ("$_QB_IDX_2")	5	
2	SINGLE CLUSTER	LOCAL/REMOTE 5	
3	SELECT STATEMENT	1	
4	QUERY BLOCK ("$_QB_IDX_2")	1	
5	NESTED JOIN (SEMI)	1	
6	INDEX ACCESS ("SUPPLIER" AS _A2, ...)	(      5)	5
7	INDEX ACCESS ("PARTSUPP" AS _A1, ...)	(      1)	1
=====

```

```
1 - TARGET : NOTHING
```

```

2 - SQL : SELECT /*+ KEEP_JOINED_TABLE USE_NL_IN( _A1 ) INDEX( _A2,
"PUBLIC"."SUPPLIER_PK_INDEX" ) INDEX( _A1, "PUBLIC"."PARTSUPP_PK_INDEX" ) */
_A2."$PHYSICAL_ROWID", _A2."S_SUPPKEY" FROM (
"PUBLIC"."SUPPLIER"@G1N1|"G1N2"|"G2N1"|"G2N2"|"G3N1"|"G3N2" AS "_A2" SEMI JOIN
"PUBLIC"."PARTSUPP"@G1N1|"G1N2"|"G2N1"|"G2N2"|"G3N1"|"G3N2" AS "_A1" ON "_A1"."PS_PARTKEY" =
_A2."S_SUPPKEY") ALIAS "_A3"

```

```
TARGET DOMAIN : G1(G1N1,G1N2) 1 rows, G2(G2N1,G2N2) 2 rows, G3(G3N1,G3N2) 2 rows
```

```
4 - TARGET : _A2.$PHYSICAL_ROWID, _A2.S_SUPPKEY
```



```

5 - JOINED COLUMN : _A2.$PHYSICAL_ROWID, _A2.S_SUPPKEY
6 - CLONED
  READ INDEX COLUMN : _A2.S_SUPPKEY
7 - HASH SHARD ( # 3 )
  READ INDEX COLUMN : _A1.PS_PARTKEY
  MIN RANGE : _A1.PS_PARTKEY = {_A2.S_SUPPKEY}
  MAX RANGE : _A1.PS_PARTKEY = {_A2.S_SUPPKEY}

```

```
<<< end print plan
```

## Global Rowid Based DML

Global rowid based DML is a method to manipulate the same records stored in different cluster members by using the rowid. This method is used when adding a new record or when **Query Based DML** is not available.

The rowid provided in cluster environment is a logical identification information given to the record and it is a standard to determine whether the records are same. If a single record is stored in different cluster members, then all of them have same rowid. Rowid information is given when creating a record, or a new rowid information is given when modifying the value of the sharding key column.

For more information about the rowid, refer to **ROWID Pseudo Column**.

Data manipulation using the rowid information is divided into a rowid information collection phase and a data manipulation phase. When manipulating two or more records, a rowid information collection phase and a data manipulation phase are repeated per record.

- The rowid information collection phase
  - It collects the rowid information of records to be added or to be manipulated.
- The data manipulation phase
  - It manipulates records of a cluster group corresponding to the collected rowid.
  - It sequentially manipulates records in a slave server after manipulating records in a master server.

Data manipulation using the rowid information supports the following two methods depending on whether to use the **Global Secondary Index**.

- **Global rowid Based DML without Using Global Secondary Index**
- **Global rowid Based DML Using Global Secondary Index**

### Global rowid Based DML without Using Global Secondary Index

Global rowid based DML without using global secondary index is used when it is not required to determine whether the update target record in a master server and that in a slave server are same. It is when it configures a new record without referring to the existing record like as INSERT.

Data manipulation using the rowid information without using the global secondary index is performed as follows.

Figure 12 Global rowid based DML without using global secondary index

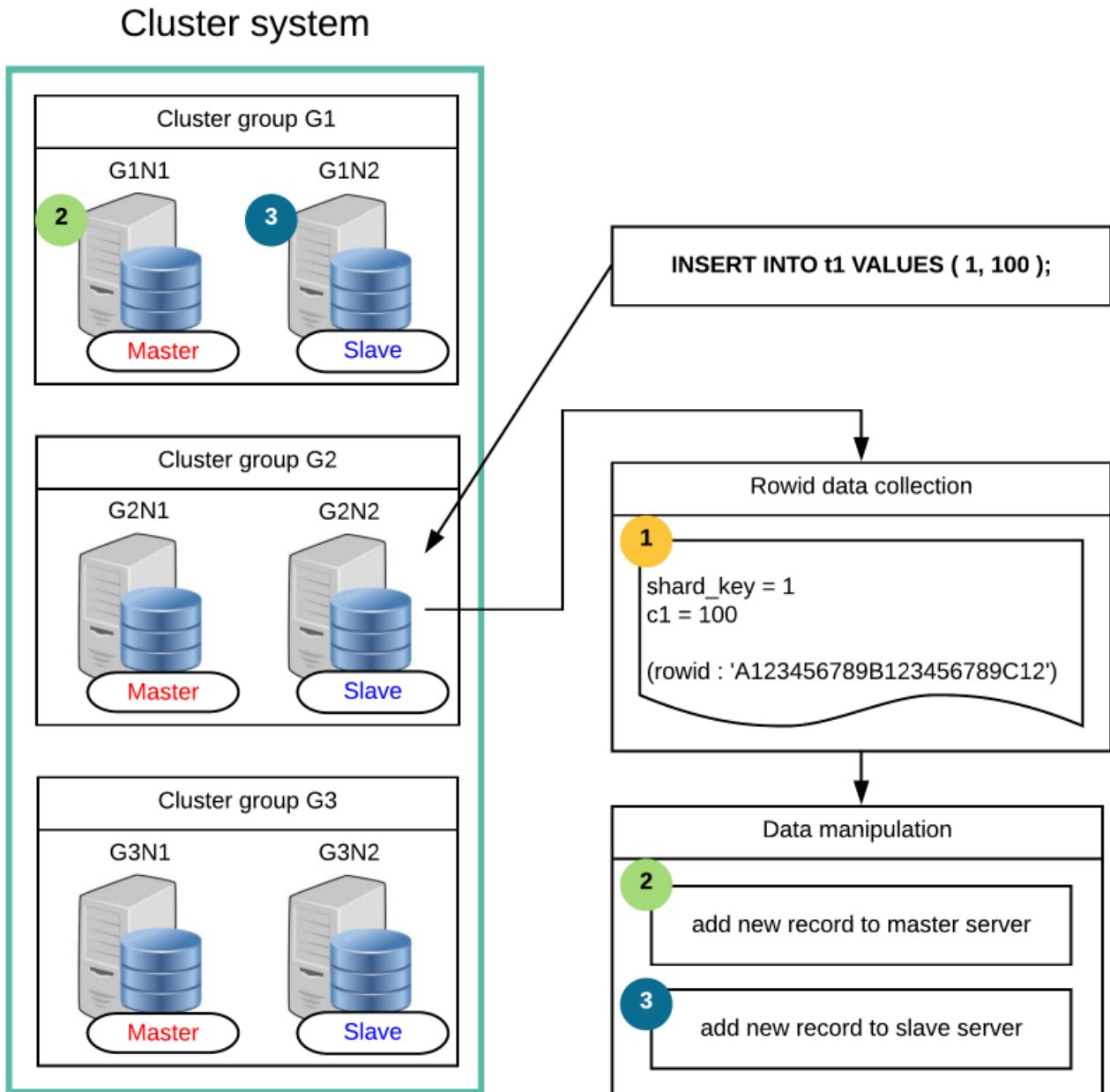

When adding a record, a rowid is given to a new record and each record is stored at an appropriate position in a master server. All records are applied to a slave server after applying to a master server.

If the sharding key column is configured by using the value (`shard_key = 1`) as given above, it is found that the record whose `shard_key` is 1 is in G1 cluster group by the sharding strategy. Therefore, the record is added only to the G1 cluster group.

The following is a result of performing user query of **Global rowid based DML without using global secondary index**. As a result, there is not any result output for global rowid based DML.

```

gSQL> \EXPLAIN PLAN INSERT INTO t1 VALUES ( 1, 100 );
1 row created.
>>> start print plan
< Execution Plan >
=====
|  IDX  |  NODE DESCRIPTION          |          ROWS |
-----|-----|-----|
|   0   |  INSERT VALUES STATEMENT ("T1") |          1 |
|   1   |    QUERY BLOCK ("SQB_IDX_2") |          0 |
|   2   |    TABLE ACCESS ("T1")      |          0 |
=====
      1 - TARGET : NOTHING
      2 - RANGE SHARD ( # 3 )
          READ COLUMN : T1.SHARD_KEY, T1.C1
<<< end print plan

```

Global rowid based DML without using global secondary index supports the following query types.

- **INSERT INTO**
- **INSERT INTO name RETURNING**
- **INSERT INTO name RETURNING .. INTO**

## Global rowid Based DML Using Global Secondary Index

The replicated record included in a master server and a slave server has the same global rowid value.

It should be guaranteed that the same data in a master server and a slave server are manipulated same by using the global rowid information to manipulate the existing record. The global secondary index is used to acquire the information about the record replicated through the global rowid.

Data manipulation using the rowid using the global secondary index is performed as follows.

Figure 13 Data manipulation using the rowid using the global secondary index

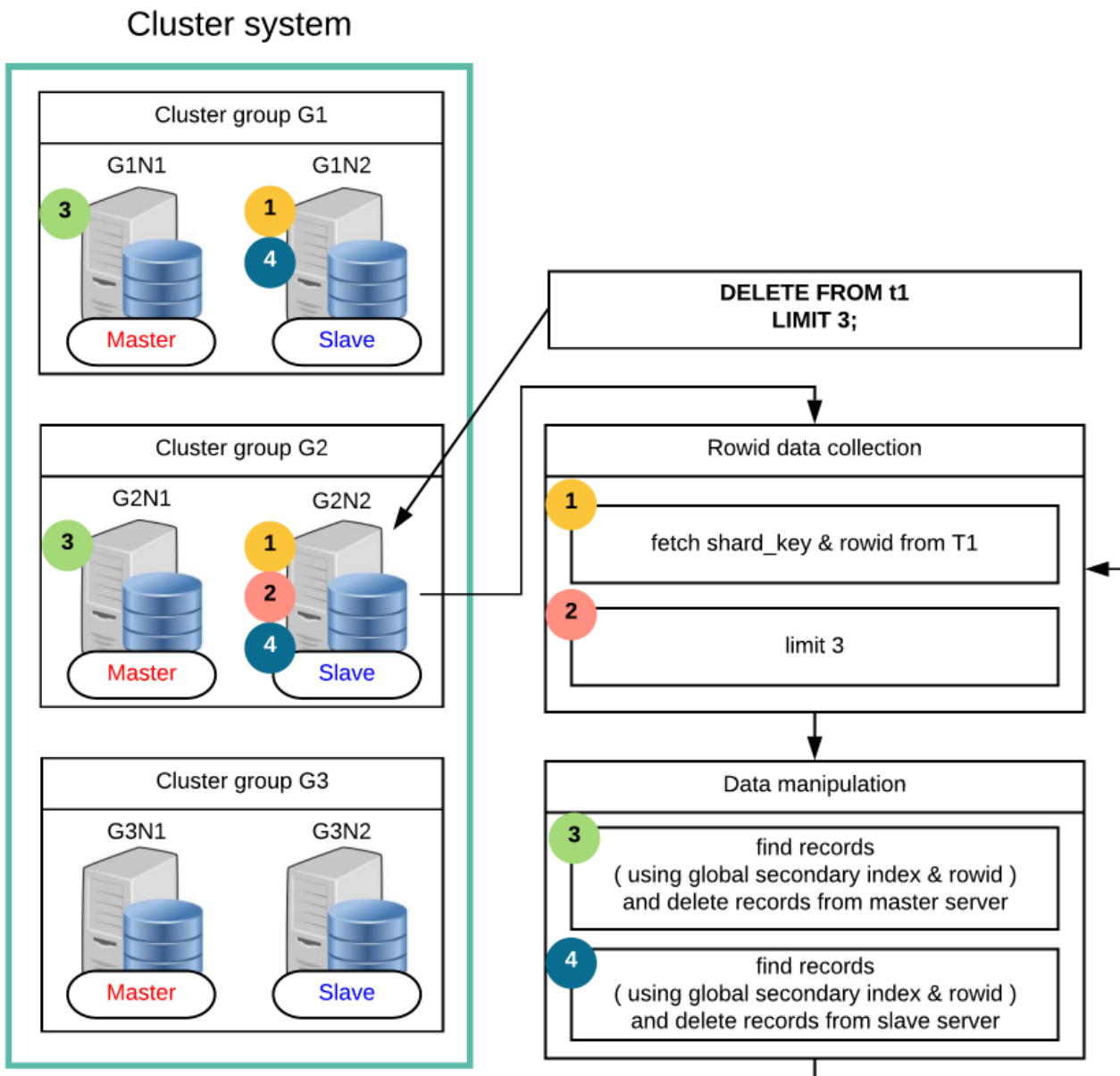

On the rowid information collection phase, the server received the user query collects row id and column value of the target record to be manipulated.

On the data manipulation phase, data in a master server and a slave server for a cluster group to which the records selected on the rowid information collection phase belong is sequentially manipulated.

On the data manipulation phase, the server which collected the rowid information, transfers it to a master server and a slave server, and requests the data manipulation. The servers received the request retrieve the target record stored in each server and manipulate it by using the received rowid information and the existing global secondary index.

The rowid information collection phase and the data manipulation phase are repeated until there is not any record to be manipulated.

The following is a result of performing user query of **Data manipulation using the rowid using the global secondary index**. As a result, there is not any result output for global rowid based DML.

```
gSQL> \EXPLAIN PLAN DELETE FROM t1 LIMIT 3;
3 rows deleted.
>>> start print plan
< Execution Plan >
=====
|  IDX  |  NODE DESCRIPTION          |          ROWS |
-----|-----|-----|
|   0   |  DELETE STATEMENT ("T1")   |             3 |
|   1   |    QUERY BLOCK ("$_QB_IDX_2") |             3 |
|   2   |    PLAN BASED CLUSTER      | LOCAL/REMOTE 3 |
|   3   |    TABLE ACCESS ("T1")    |             2 |
=====
      1 - TARGET : NOTHING
      2 - SQL : SELECT /*+ FULL( _A1 ) */ "_A1"."$PHYSICAL_ROWID" FROM "PUBLIC"."T1"@LOCAL AS
"_A1"
          TARGET DOMAIN : G1(G1N1,G1N2) 2 rows, G2(G2N1,G2N2) 1 rows, G3(G3N1,G3N2) 0 rows
      3 - RANGE SHARD ( # 3 )
          READ COLUMN : NOTHING
<<< end print plan
```

Global rowid based DML using global secondary index supports the following query types.

- SELECT .. FOR UPDATE
- SELECT .. INTO .. FOR UPDATE
- DELETE FROM
- DELETE FROM name RETURNING
- DELETE FROM name RETURNING .. INTO
- DELETE FROM name WHERE CURRENT OF cursor\_name
- UPDATE
- UPDATE name RETURNING
- UPDATE name RETURNING .. INTO
- UPDATE name WHERE CURRENT OF cursor\_name



# 13.

---

## SQL Objects

This chapter describes the concepts and features of the following objects which configure the database.

- Authorization: User and privilege
- Schema
- Tablespace
- Table
- Index
- Sequence
- View
- Synonym
- Stored procedure
- Stored function

## 13.1 Database

### Database-related Statements

For more information, refer to the followings.

- Starting up the database: **ALTER SYSTEM {MOUNT | OPEN} DATABASE**
- Backup and recovery
  - **ALTER DATABASE BACKUP**
  - **ALTER DATABASE DELETE BACKUP**
  - **ALTER DATABASE RECOVER**
  - **ALTER DATABASE REGISTER**
  - **ALTER DATABASE RESTORE**
- Creating, dropping, altering log files
  - **ALTER SYSTEM CHECKPOINT**
  - **ALTER SYSTEM SWITCH LOGFILE**
  - **ALTER DATABASE ARCHIVELOG**
  - **ALTER DATABASE ADD LOGFILE**
  - **ALTER DATABASE DROP LOGFILE**
  - **ALTER DATABASE RENAME LOGFILE**
- Comments on objects: **COMMENT ON name IS**
- System statistics information: **ANALYZE SYSTEM**

The information which is related to the database objects can be retrieved through the following views.

**Table 13-1** Database object related information

| Schema             | View name                              | Description                                               |
|--------------------|----------------------------------------|-----------------------------------------------------------|
| DICTIONARY_SCHEMA  | <b>ALL_NONSCHEMA_COMMENTS</b>          | Comment information of user accessible non-schema objects |
| INFORMATION_SCHEMA | <b>INFORMATION_SCHEMA_CATALOG_NAME</b> | Database name information                                 |
|                    | <b>SQL_FEATURES</b>                    | The SQL standard compatibility information of GOL DILOCKS |
|                    | <b>SQL_IMPLEMENTATION_INFO</b>         | The SQL standard compatibility information of GOL DILOCKS |
|                    | <b>SQL_PACKAGES</b>                    | The SQL standard compatibility information of GOL         |



| Schema | View name  | Description                                                  |
|--------|------------|--------------------------------------------------------------|
|        |            | DILOCKS                                                      |
|        | SQL_PARTS  | The SQL standard compatibility information of GOL<br>DILOCKS |
|        | SQL_SIZING | The SQL standard compatibility information of GOL<br>DILOCKS |

## Database Configuration Objects

### SQL Objects that Configure the Database

A database consists of multiple SQL objects.

SQL objects in database are classified as SQL schema objects and non-schema objects, depending on whether they are included in the SCHEMA.

Figure 1 SQL objects

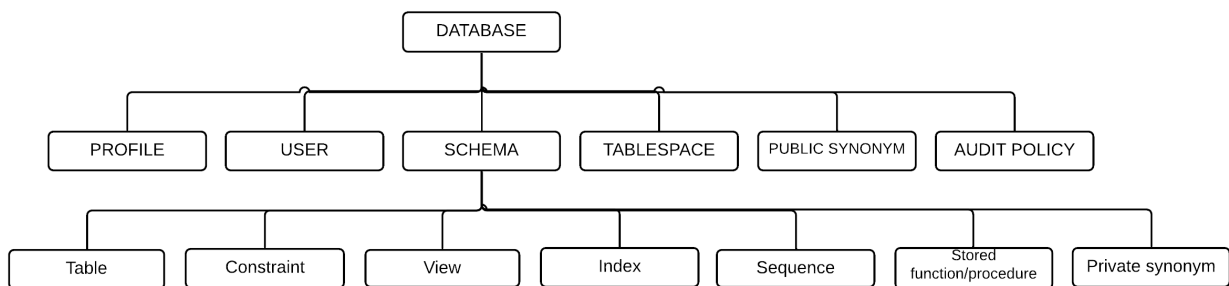

SQL schema objects are included in the SCHEMA, and they are as follows.

- **TABLE:** It is an object which stores the physical data, and it consists of columns and rows.
- **VIEW:** It is a logical object which provides a relation name for the query, and it is similar to a table.
- **INDEX:** It is an object to improve the query performance.
- **SEQUENCE:** It is an object to generate numbers.
- **CONSTRAINT:** It is an object to retain the integrity of tables.
- **SYNONYM:** It is an alias of TABLE, VIEW, SEQUENCE, and other synonym.
- **STORED PROCEDURE:** It is a persistent stored module in a procedure form.
- **STORED FUNCTION:** It is a persistent stored module in a function form.

SQL schema object can be used together with a schema name, or it can be used omitting a schema name. If schema name is omitted, the name is interpreted by the user's schema path.

The following is an example of when objects are created by specifying the schema name.

```
gSQL> CREATE TABLE my_schema.lineitem ( id INTEGER );
gSQL> CREATE INDEX my_schema.my_index ON my_schema.lineitem ( id );
```

Non-schema object is not included in the schema, and they are as follows.

- PROFILE: It is a password management policy.
- AUDIT POLICY: It is an audit policy.
- USER: It is a user.
- SCHEMA: It is the logical locations of the SQL schema objects.
- TABLESPACE: It is the physical spaces of the SQL schema objects.
- PUBLIC SYNONYM: It is an alias of TABLE, VIEW, SEQUENCE, and other synonym which does not have schema name

The SQL standard explicitly defines concepts and syntax for the SCHEMA objects. However, the concepts of USER and DATABASE are described only, and their syntaxes are not defined in SQL. The SQL standard does not deal with the TABLESPACE object. Namely, the SQL standard does not explicitly define the non-schema objects.

GOLDILOCKS defines USER, SCHEMA, TABLESPACE as separate descendant of a database. However, other DBMS vendors define the concepts of non-schema objects as follows.

- GOLDILOCKS
  - User and schema are separate objects.
  - User either does not have a schema, or has multiple schemas.
  - The relationship between user and schema is User : Schema = 1 : N.
- Oracle
  - User and schema are defined as similar concepts.
  - The relationship between user and schema is User : Schema = 1 : 1.
- DB2
  - User is not a descendant of DATABASE.
  - The relationship between user and schema is User : Schema = 1 : N.
- Postgres
  - User is not a descendant of DATABASE.
  - The relationship between user and schema is User : Schema = 1 : N.
- MySQL
  - User and schema are defined as similar concepts.
  - User is a descendant of DATABASE(SCHEMA).

## Name Space of Objects

An object in the database has an identifiable name.

An SQL schema object has a unique name within a schema.

For example, the same lineitem table objects can be created in different schemas as follows.

```
gSQL> CREATE TABLE my_schema.lineitem ( id INTEGER );
gSQL> CREATE TABLE your_schema.lineitem ( name VARCHAR(128) );
```

SQL schema objects have the following name spaces in a single schema as follows.

- TABLE, VIEW, SEQUENCE, PRIVATE SYNONYM, STORED PROCEDURE, STORED FUNCTION
- INDEX
- CONSTRAINT

Table and view can not be created under the same name, but table and index can be created under the same name, as follows.

- Table and view can not be created under the same name.

```
gSQL> CREATE TABLE my_relation ( id INTEGER );
gSQL> CREATE VIEW my_relation ( name ) AS SELECT name FROM tmp_relation;
```

- Table and index can be created under the same name.

```
gSQL> CREATE TABLE my_object ( id INTEGER );
gSQL> CREATE INDEX my_object ON my_table ( name );
```

A non-schema object has an identifiable name within a database. Non-schema objects have the name spaces as follows.

- PROFILE
- AUDIT POLICY
- USER
- SCHEMA
- TABLESPACE

Namely, USERS can not be created under the same name, but USER and SCHEMA can be created under the same name.

- my\_name USER object and my\_name SCHEMA object are created.

```
gSQL> CREATE USER my_name IDENTIFIED BY my_name WITH SCHEMA my_name;
```

## Built-in Objects

When creating database, GOLDILOCKS automatically creates objects such as user, schema, tablespace which are necessary for system operation.

## Built-in User

When creating database, the following accounts are automatically created. The built-in accounts can not be removed except TEST user.

- `_SYSTEM` account
  - It is an account used by the internal system. When creating database, it is the owner of the built-in objects. When user creates an object, it becomes the grantor who grants the privilege to the object owner.
- `SYS` account
  - It is a user to manage the database.
- `TEST` account
  - It is a user for testing, and this object can be removed.
- `ADMIN` account
  - It is a role to manage the database.
- `SYSDBA` account
  - It is a role to start up/shut down the database.
- `PUBLIC` account
  - It is an account for all users. It is used to control the privileges for all users.

## Built-in Schema

When creating database, the following schemas are automatically created. All built-in schemas can not be removed.

- `DEFINITION_SCHEMA`
  - It consists of the physical tables which store all objects information of the database.
- `FIXED_TABLE_SCHEMA`
  - It consists of the fixed tables which display the data structure information of system in a table form.
- `DICTIONARY_SCHEMA`
  - It consists of the user perspective views for querying object information of the database.

- INFORMATION\_SCHEMA
  - It consists of the views defined in the SQL standard for querying the object information of the database.
- PERFORMANCE\_VIEW\_SCHEMA
  - It consists of the user perspective views for querying the state of the system.
- SESSION\_SCHEMA
  - It is the schema to manage objects in session unit, and the user can not use it.
- PUBLIC
  - It is the schema in which all users can create objects, and it differs from the PUBLIC account, which means all users.

## Built-in Tablespace

When creating database, the following tablespaces are created automatically. All the built-in tablespaces can not be removed.

- DICTIONARY\_TBS
  - It stores the dictionary tables to manage the SQL objects information.
- MEM\_UNDO\_TBS
  - It stores undo segments and transactions information.
- MEM\_DATA\_TBS
  - It is the first created data tablespace.
  - The user created tables are stored in data tablespace.
- MEM\_TEMP\_TBS
  - It is the first created temporary tablespace.
  - The temporary objects such as sort and hash which are created during query processing are stored in the temporary tablespace.
- DISK\_DATA\_TBS
  - It is the first created disk data tablespace.
  - The data tablespace stores objects such as a user-created table.
- MEM\_AUX\_TBS
  - It is a system auxiliary tablespace and it stores records which is automatically created such as an audit record.
- MEM\_TRANS\_TBS
  - It is valid in the cluster system, and manages the global transaction information.
  - It is not created in the standalone system.

## Built-in Profile

When creating database, the "DEFAULT" profile is automatically created. Password parameter information of the "DEFAULT" profile is as follows.

**Table 13-2** Configuration of DEFAULT profile

| Parameter                | Value     |
|--------------------------|-----------|
| FAILED_LOGIN_ATTEMPTS    | 10        |
| PASSWORD_LOCK_TIME       | 1         |
| PASSWORD_LIFE_TIME       | 180       |
| PASSWORD_GRACE_TIME      | 7         |
| PASSWORD_REUSE_MAX       | UNLIMITED |
| PASSWORD_REUSE_TIME      | UNLIMITED |
| PASSWORD_VERIFY_FUNCTION | NULL      |

The followings are characteristics of the default values of "DEFAULT" profile.

- Account lockout
  - An account is locked for one day (PASSWORD\_LOCK\_TIME) after consecutive 10(FAILED\_LOGIN\_ATTEMPTS) times of failed login attempts.
- Password expiration
  - After 180 days (PASSWORD\_LIFE\_TIME) has elapsed, the password expires after seven days of grace period (PASSWORD\_GRACE\_TIME).
- Password reusable
  - The old password can be reused.
- Password complexity verification
  - The password complexity is not verified.

## 13.2 Profile

### Profile-related Statements

For more information, refer to the followings.

- Creating a profile: **CREATE PROFILE**.
- Dropping a profile: **DROP PROFILE**.
- Altering a profile: **ALTER PROFILE**.
- Assigning a profile to the user: **CREATE USER, ALTER USER**
- Clearing a password history: **ALTER DATABASE CLEAR PASSWORD HISTORY**.

**Table 13-3** Profile object related information

| Schema            | View         | Description              |
|-------------------|--------------|--------------------------|
| DICTIONARY_SCHEMA | DBA_PROFILES | All profile information  |
|                   | DBA_USERS    | User profile information |

### Concepts of Profile

GOLDILOCKS performs user authentication for database security. The password management policy is required because the user authentication password is vulnerable to theft, forgery and misuse.

Profile includes information such as this password management policy. DBA or security managers assign the profile to a user, and apply the password management policy which is appropriate to the corresponding user.

### Creating, Altering, Allocating Profile

A profile is created by using CREATE PROFILE statement.

```
CREATE PROFILE profile1 LIMIT
    FAILED_LOGIN_ATTEMPTS    10
    PASSWORD_LOCK_TIME       1
    PASSWORD_LIFE_TIME        180
    PASSWORD_GRACE_TIME       7
    PASSWORD_REUSE_MAX        UNLIMITED
    PASSWORD_REUSE_TIME        UNLIMITED
```

```
PASSWORD_VERIFY_FUNCTION NULL;
```

A profile is allocated by using CREATE USER, ALTER USER statements.

```
CREATE USER u1 IDENTIFIED BY u1 PROFILE profile1;
ALTER USER u2 PROFILE profile1;
```

The profile parameters are updated by using ALTER PROFILE statement.

```
ALTER PROFILE profile1 LIMIT
    PASSWORD_REUSE_MAX          3
    PASSWORD_REUSE_TIME        30;
```

If a profile is not allocated to a user, the user is not restricted on creating and using the password.

If the created profile or a DEFAULT profile is allocated to a user, the user complies with the profile's password policies when creating and using the password.

## Setting Password of DEFAULT Profile

When the default profile is assigned to a user, the password is managed as follows.

**Table 13-4** DEFAULT profile of password

| Parameter            | Default setting | Description                                                                                                                                                                                                                                                                      |
|----------------------|-----------------|----------------------------------------------------------------------------------------------------------------------------------------------------------------------------------------------------------------------------------------------------------------------------------|
| FAILED_LOGIN_ATTEMPS | 10              | The allowed number of consecutive login failure<br>The account is locked after consecutive 10 times login attempt failures.                                                                                                                                                      |
| PASSWORD_LOCK_TIME   | 1               | The account lockout duration<br>If the consecutive login failures exceed the allowable value, the account is locked for one day.                                                                                                                                                 |
| PASSWORD_LIFE_TIME   | 180             | The password life time<br>The password is expired after 180 days.                                                                                                                                                                                                                |
| PASSWORD_GRACE_TIME  | 7               | The duration to change the password when the the password is expired.<br>The password should be changed within seven days after first login since the password is expired. If a user does not change the password within the period, the user can not log in using the password. |
| PASSWORD_REUSE_MAX   | UNLIMITED       | The number of times of which passwords are not reusable.<br>PASSWORD_REUSE_MAX should be set together with PASSWORD_REUSE_TIME. If both of the two values are UNLIMITED, the password can always be reused.                                                                      |
| PASSWORD_REUSE_TIME  | UNLIMITED       | The duration which the password can not be reused.                                                                                                                                                                                                                               |



## Account Lockout

If the number of consecutive login attempt failures exceeds the number of times specified in `FAILED_LOGIN_ATTEMPTS`, the account is locked during the period specified in `PASSWORD_LOCK_TIME`.

```
CREATE PROFILE profile1 LIMIT
    FAILED_LOGIN_ATTEMPTS    10
    PASSWORD_LOCK_TIME       1;
ALTER USER u1 PROFILE profile1;
```

When a user `u1`'s login attempts consecutively fail more than 10 times, the account is locked for one day. And after one day the account is automatically unlocked.

If the `PASSWORD_LOCK_TIME` value is not specified, it is regarded as the value which is specified in `PASSWORD_LIFE_TIME` of `DEFAULT` profile.

If the `PASSWORD_LOCK_TIME` value is `UNLIMITED` the locked accounts are not automatically released. Therefore, the following statement should be executed to unlock the account.

```
ALTER USER u1 ACCOUNT UNLOCK;
```

If login is successful, the number of failed login attempt is initialized to zero.

A security manager can explicitly lock the user accounts. In this case, the user accounts can not be automatically released so the security manager should unlock the user accounts.

```
ALTER USER u1 ACCOUNT LOCK;
ALTER USER u1 ACCOUNT UNLOCK;
```

## Password Lifetime

`PASSWORD_LIFE_TIME` specifies the life time the password. After the life time, the password is expired. A user, DBA or security manager should change the password after a password is expired.

```
CREATE PROFILE profile1 LIMIT
    PASSWORD_LIFE_TIME       180
    PASSWORD_GRACE_TIME      7;
ALTER USER u1 PROFILE profile1;
```

The grace period starts since when the user `u1` has tried to log in for the first time after 180 days.

During seven days of the grace period, the user is reminded to enter a new password whenever accessing the account, until he changes the password.

If seven days of the grace period passed and the password is not changed, the user can not login until entering a new password.

A password can be expired by using CREATE USER or ALTER USER statements.

```
ALTER USER u1 PASSWORD EXPIRE;
```

When the password is expired, the error (ERR-28000(16312) the password has expired) occurs whenever logging in as follows, then a new password should be entered.

```
% gsql u1 u1
ERR-28000(16312): the password has expired
Changing password for u1
New password:
Retype new password:
Connected to GOLDILOCKS Database.
gSQL>
```

## Reusing Password

The password can be reused after it is changed as many times as the specified value in PASSWORD\_REUSE\_MAX. Also, it should be after the specified time in PASSWORD\_REUSE\_TIME.

```
CREATE PROFILE profile1 LIMIT
    PASSWORD_REUSE_MAX          2
    PASSWORD_REUSE_TIME         1;
ALTER USER u1 PROFILE profile1;
```

The user u1 can reuse the current password after the password has been changed for two times, and 10 days elapsed.

```
ALTER USER u1 IDENTIFIED BY u1 REPLACE u1;
ALTER USER u1 IDENTIFIED BY u1 REPLACE u1
*
ERROR at line 1:
ORA-28007: the password cannot be reused
ALTER USER u1 IDENTIFIED BY u2 REPLACE u1;
User altered.
ALTER USER u1 IDENTIFIED BY u3 REPLACE u2;
User altered.
```

- 10 days elapsed.

```
ALTER USER u1 IDENTIFIED BY u1 REPLACE u3;
User altered.
```

The both conditions should be satisfied to reuse the old password. If only one of the value in PASSWORD\_REUSE\_MAX and PASSWORD\_REUSE\_TIME is UNLIMITED, the password can not be reused. If both of values are UNLIMITED, the password can always be reused.

**Table 13-5** Password reuse

| PASSWORD_REUSE_MAX | PASSWORD_REUSE_TIME | Password reusability                                       |
|--------------------|---------------------|------------------------------------------------------------|
| Integer value      | Integer value       | If both of the conditions are satisfied, it can be reused. |
| Integer value      | UNLIMITED           | It can not be reused.                                      |
| UNLIMITED          | Integer value       | It can not be reused.                                      |
| UNLIMITED          | UNLIMITED           | It can always be reused.                                   |

## Password Complexity Verification

Password complexity verification checks if the password is complex enough to protect against breaking in to the system.

GOLDILOCKS supports the method of password complexity verification as follows.

**Table 13-6** Password complexity verification

| Method                 | Description                                                                                                                                                                                                                                                                                                                                                                                                                                                                                                                                                                                                                                                 |
|------------------------|-------------------------------------------------------------------------------------------------------------------------------------------------------------------------------------------------------------------------------------------------------------------------------------------------------------------------------------------------------------------------------------------------------------------------------------------------------------------------------------------------------------------------------------------------------------------------------------------------------------------------------------------------------------|
| KISA_VERIFY_FUNCTION   | <ul style="list-style-type: none"> <li>8 or more characters</li> <li>1 or more letters</li> <li>1 or more numbers</li> <li>1 or more special characters</li> </ul>                                                                                                                                                                                                                                                                                                                                                                                                                                                                                          |
| ORA12C_VERIFY_FUNCTION | <ul style="list-style-type: none"> <li>8 or more characters</li> <li>1 or more letters</li> <li>1 or more numbers</li> <li>Database name should not be included.</li> <li>Username or the reversed username should not be included.</li> <li><i>goldilocks</i> should not be included.</li> <li><i>oracle</i> should not be included.</li> <li>The following simple password can not be used. <ul style="list-style-type: none"> <li>welcome1, database1, account1, user1234, password1, oracle123, computer1, abcdefg1, change_on_intall</li> </ul> </li> <li>The new password should be different at least 3 characters from the old password.</li> </ul> |
|                        | <ul style="list-style-type: none"> <li>9 or more characters</li> <li>2 or more uppercases</li> </ul>                                                                                                                                                                                                                                                                                                                                                                                                                                                                                                                                                        |

| Method                        | Description                                                                                                                                                                                                                                                                                                                                                                                                                                                                                                 |
|-------------------------------|-------------------------------------------------------------------------------------------------------------------------------------------------------------------------------------------------------------------------------------------------------------------------------------------------------------------------------------------------------------------------------------------------------------------------------------------------------------------------------------------------------------|
| ORA12C_STRONG_VERIFY_FUNCTION | <ul style="list-style-type: none"> <li>• 2 or more lowercases</li> <li>• 2 or more numbers</li> <li>• 2 or more special characters</li> <li>• The new password should be different at least 4 characters from the old password.</li> </ul>                                                                                                                                                                                                                                                                  |
| VERIFY_FUNCTION_11G           | <ul style="list-style-type: none"> <li>• 8 or more characters</li> <li>• 1 or more letters</li> <li>• 1 or more numbers</li> <li>• Username should not be included.</li> <li>• The new password should be different at least 3 characters from the old password.</li> </ul>                                                                                                                                                                                                                                 |
| VERIFY_FUNCTION               | <ul style="list-style-type: none"> <li>• It should not be same as the username.</li> <li>• 4 or more characters</li> <li>• 1 or more letters</li> <li>• 1 or more numbers</li> <li>• 1 or more special characters</li> <li>• The following simple password can not be used. <ul style="list-style-type: none"> <li>◦ welcome, database, account, user, password, oracle, computer, abcd</li> </ul> </li> <li>• The new password should be different at least 3 characters from the old password.</li> </ul> |

For more information about profile and user setting, refer to **CREATE PROFILE, CREATE USER**.

## 13.3 Audit Policy

### Audit Policy-related Statement

For more information, refer to the followings.

- Creating audit policy: **CREATE AUDIT POLICY**
- Dropping audit policy: **DROP AUDIT POLICY**
- Altering audit policy: **ALTER AUDIT POLICY**
- Activating audit policy: **AUDIT POLICY**
- Deactivating audit policy: **NOAUDIT POLICY**
- Dropping audit trail: **ALTER DATABASE CLEAR AUDIT TRAIL**

**Table 13-7** Audit policy object information

| Schema            | View                 | Description                               |
|-------------------|----------------------|-------------------------------------------|
| DICTIONARY_SCHEMA | AUDIT_POLICIES       | Information about all audit policies      |
|                   | AUDIT_POLICY_OPTIONS | Information about audit policy option     |
|                   | AUDIT_POLICY_ENABLED | Information about activating audit policy |

### Examples

AUDIT SYSTEM ON DATABASE privilege is required to perform the followings.

#### Creating Audit Policy

Perform **CREATE AUDIT POLICY** statement to create an audit policy object.

The following is an example of creating an audit\_t1\_dml object to audit the DML for a u1.t1 table.

```
CREATE AUDIT POLICY audit_t1_dml
  ACTIONS INSERT ON u1.t1
        , DELETE ON u1.t1
        , UPDATE ON u1.t1
;
```

Audit policy created.

Enquire the information about audit policy options by using **AUDIT\_POLICY\_OPTIONS** view.

```

SELECT policy_name
       , audit_option
       , object_schema
       , object_name
FROM   audit_policy_options
WHERE  policy_name = 'AUDIT_T1_DML'
ORDER BY audit_option
;
POLICY_NAME  AUDIT_OPTION  OBJECT_SCHEMA  OBJECT_NAME
-----
AUDIT_T1_DML DELETE        U1             T1
AUDIT_T1_DML INSERT         U1             T1
AUDIT_T1_DML UPDATE         U1             T1
3 rows selected.

```

## Activating Audit Policy

Use **AUDIT POLICY** statement to activate the audit policy.

The following is an example of activating an audit policy to leave an audit record when a user except for u1, sys succeeded to perform DML for u1.t1 table.

```

AUDIT POLICY audit_t1_dml
  EXCEPT u1, sys
  WHENEVER SUCCESSFUL
;

```

The activated audit policy is applied to the newly created session, but it does not affect the existing sessions.

View the information about activated audit policy by using **AUDIT\_POLICY\_ENABLED**.

```

SELECT policy_name
       , enabled_opt
       , user_name
       , when_success
       , when_failure
FROM   audit_policy_enabled
WHERE  policy_name = 'AUDIT_T1_DML'
ORDER BY user_name
;
POLICY_NAME          ENABLED_OPT          USER_NAME  WHEN_SUCCESS  WHEN_FAILURE

```

```

-----
AUDIT_T1_DML      EXCEPT          SYS      YES      NO
AUDIT_T1_DML      EXCEPT          U1      YES      NO
2 rows selected.

```

After the audit policy is activated, the corresponding actions create audit records.

The following is an example of when u2 user successfully performs SQL statements.

```

SELECT COUNT(*) FROM u1.t1;
INSERT INTO u1.t1 VALUES ( 1 );
UPDATE u1.t1 SET id = id + 1 WHERE id = 1;
DELETE u1.t1 WHERE id = 2;
COMMIT;

```

In the example above, INSERT, UPDATE, DELETE are target actions of an audit, so it creates audit records, but SELECT and COMMIT are not a target action of an audit, so it does not create audit records.

## Viewing Audit Trail

SELECT ON DICTIONARY\_SCHEMA.AUDIT\_TRAIL privilege for AUDIT\_TRAIL view is required to view audit records.

The following is an example of viewing an audit trail created by an audit\_t1\_dml audit policy.

```

SELECT policy_name
       , logon_username
       , action_name
       , object_schema
       , object_name
       , sql_text
FROM audit_trail
WHERE policy_name = 'AUDIT_T1_DML'
;
POLICY_NAME LOGON_USERNAME ACTION_NAME OBJECT_SCHEMA OBJECT_NAME SQL_TEXT
-----
-----
AUDIT_T1_DML U2          INSERT      U1          T1          INSERT INTO u1.t1 VALUES ( 1
)
AUDIT_T1_DML U2          UPDATE      U1          T1          UPDATE u1.t1 SET c1 = c1 + 1
WHERE c1 = 1
AUDIT_T1_DML U2          DELETE      U1          T1          DELETE u1.t1 WHERE c1 = 2
3 rows selected.

```

## Dropping Audit Trail

When an audit policy is activated, the size of an audit trail keeps increasing. Execute the following statement to drop the audit trail.

```
ALTER DATABASE CLEAR AUDIT TRAIL;
```

Store it in the user table and drop it as follows to store the audit trail.

- Creating a user table

```
CREATE TABLE my_audit_trail  
AS SELECT *  
FROM audit_trail  
WITH NO DATA;
```

- Storing it in a user table, then dropping it.

```
INSERT INTO my_audit_trail SELECT * FROM audit_trail;  
ALTER DATABASE CLEAR AUDIT TRAIL;
```

Create and manage the view as follows to view both the stored audit trail and the current audit\_trail.

```
CREATE VIEW unified_audit_trail  
AS  
SELECT * FROM my_audit_trail  
UNION ALL  
SELECT * FROM dictionary_schema.audit_trail  
;
```

## Deactivating Audit Policy

Deactivate the audit policy by using the following statement.

```
NOAUDIT POLICY audit_t1_dml;
```

Deactivating audit policy affects the newly created session, but it does not affect the activated information about existing sessions.



## Dropping Audit Policy

Execute the following statement to drop the audit policy object.

```
DROP AUDIT POLICY audit_t1_dml;
```

The audit policy object should be deactivated to be dropped, and dropping the object does not affect the existing sessions.

## Concepts of Audit Policy

### Audit Trail

#### Viewing Audit Trail

Audit record can be viewed by using `DICTIONARY_SCHEMA.AUDIT_TRAIL` view.

`SELECT` privilege is required to view `AUDIT_TRAIL` view.

```
GRANT SELECT ON DICTIONARY_SCHEMA.AUDIT_TRAIL TO user_name;
```

`AUDIT_TRAIL` view has the following information.

**Table 13-8** Column information

| Information             | Column name         | Description                                                             |
|-------------------------|---------------------|-------------------------------------------------------------------------|
| Session information     | MEMBER_NAME         | Cluster member name                                                     |
|                         | SESSION_ID          | Session identifier                                                      |
|                         | SESSION_SERIAL      | Session serial number                                                   |
|                         | LOGON_USERNAME      | Logon user name of the user whose actions were audited                  |
|                         | CURRENT_USERNAME    | Effective user for the statement execution                              |
|                         | SERVER_PROCESS      | Server process identifier for the session                               |
| Peer client information | CLIENT_PROGRAM_NAME | Client program used for session                                         |
|                         | CLIENT_USERNAME     | Client operating system user name for the session                       |
|                         | CLIENT_PROCESS      | Client process identifier for the session                               |
|                         | CLIENT_HOST         | Client host ip address for the session                                  |
|                         | CLIENT_PORT         | Client port number for the session                                      |
|                         | CLIENT_TERMINAL     | Client terminal name for the session                                    |
|                         | TRANSACTION_ID      | Transaction identifier                                                  |
|                         | SCN                 | System change number (SCN) string of the query at the time of the event |

| Information       | Column name     | Description                                                           |
|-------------------|-----------------|-----------------------------------------------------------------------|
| SQL information   | GCN             | Global change number (GCN) of the query at the time of the event      |
|                   | DCN             | Domain change number (DCN) of the query at the time of the event      |
|                   | LCN             | Local change number (LCN) of the query at the time of the event       |
|                   | STMT_NO         | Numeric number for each statement run in a session                    |
|                   | SQL_TEXT        | SQL associated with the event                                         |
|                   | SQL_BINDS       | List of bind variables, if any, associated with SQL_TEXT              |
|                   | RETURN_CODE     | Error code generated by the action, zero if the action succeeded      |
|                   | ERROR_MESSAGE   | Error message generated by the action, null if the action succeeded   |
| Event information | ENTRY_ID        | Audit trail entry identifier in the session                           |
|                   | EVENT_TIMESTAMP | Timestamp of the creation of the audit trail entry in local time zone |
|                   | POLICY_NAME     | Audit policy name that caused the current audit record                |
|                   | PRIVILEGE_USED  | Database privilege used to execute the action                         |
|                   | ACTION_NAME     | Action name executed by the user                                      |
|                   | OBJECT_TYPE     | Object type of object affected by the action                          |
|                   | OBJECT_SCHEMA   | Schema name of object affected by the action                          |
|                   | OBJECT_NAME     | Object name of object affected by the action                          |

## Storing Audit Trail

AUDIT\_TRAIL view consists of the following tables.

- AUDIT\_TRAIL\_SESSION
  - It records a record per a session.
  - Session information
  - Peer client information
- AUDIT\_TRAIL\_SQL
  - It records a record per SQL.
  - SQL information
- AUDIT\_TRAIL\_EVENT
  - It records a record per an audit option.
  - Audit event information

Audit records configuring an audit trail is divided into multiple tables then stored.

The schema of the tables is DEFINITION\_SCHEMA, and it is stored in MEM\_AUX\_TBS tablespace.

- DEFINITION\_SCHEMA
  - It is a schema storing dictionary tables.
- MEM\_AUX\_TBS
  - System auxiliary tablespace
  - It is a tablespace to store a record which automatically created by the database.
  - It is managed by a separate tablespace not to affect the service management by an automatically

created record.

## Creating Audit Record

If an audit policy is activated, it creates an audit record when the corresponding action occurs. It creates one or more audit records when multiple corresponding actions occur.

- If similar audit options are listed as follows, it creates a single audit record.
  - Defining an audit policy

```
CREATE AUDIT POLICY p1
  PRIVILEGES INSERT ANY TABLE
  ACTIONS INSERT;
AUDIT POLICY p1;
```

- Performing an audit action

```
INSERT INTO other_user.t1 VALUES ( 1 );
```

- If different audit options are listed as follows, it creates two audit records.
  - Defining an audit policy

```
CREATE AUDIT POLICY p1
  ACTIONS SELECT ON u1.t1
           , SELECT ON u1.t2;
AUDIT POLICY p1;
```

- Performing an audit action

```
SELECT COUNT(*) FROM u1.t1 A, u1.t2 B WHERE A.id = B.id;
```

- If multiple audit policies are activated in the identical action as follows, it creates two audit records.
  - Defining an audit policy

```
CREATE AUDIT POLICY p1
  PRIVILEGES INSERT ANY TABLE;
AUDIT POLICY p1;
CREATE AUDIT POLICY p2
  ACTIONS INSERT;
AUDIT POLICY p2;
```

- Performing an audit action

```
INSERT INTO other.t1 VALUES (1);
```

## Dropping Audit Trail (purge)

Execute the following statement to drop the audit trail.

```
ALTER DATABASE CLEAR AUDIT TRAIL;
```

Create a user table and store old audit record in it as follows.

```
CREATE TABLE my_audit_trail AS SELECT * FROM audit_trail WITH NO DATA;
```

Then, regularly store it by using INSERT .. SELECT statement before dropping the audit trail.

```
INSERT INTO my_audit_trail SELECT * FROM audit_trail;
ALTER DATABASE CLEAR AUDIT TRAIL;
```

Execute DELETE statement by using EVENT\_TIMESTAMP column to store the audit record of the specified period.

```
INSERT INTO my_audit_trail SELECT * FROM audit_trail;
DELETE FROM my_audit_trail WHERE event_timestamp < ADD_MONTHS( sysdate, -3 );
ALTER DATABASE CLEAR AUDIT TRAIL;
```

View the old audit record and the current audit record together by creating a view as follows.

```
CREATE VIEW audit_trail_view
AS SELECT * FROM dictionary_schema.audit_trail
   UNION ALL
   SELECT * FROM my_audit_trail;
SELECT * FROM audit_trail_view;
```

## Configuring Audit Policy

Audit policy may include the following options.

- Privilege auditing
  - It audits SQL performance by using the database privilege.
- Object action auditing
  - It audits SQL performance for the specific object.
- System action auditing

- It audits SQL performance for all objects.

Multiple audit options can be managed by creating multiple audit policies, but it is recommended to manage multiple audit options by creating a small number of audit policies.

The activated audit policy information is constructed as a session information at logon time, so the less the number of audit policies, the less the load becomes.

Moreover, if multiple audit policies are activated, then it determines whether to create an audit record for an SQL statement, so a load creating multiple audit records may occur.

Audit policy information constructed in a session at logon time is not affected by dropping, altering, activating or deactivating an audit policy.

Altering an audit policy is applied only to a newly logon session.

## Privilege Auditing

Privilege auditing is set to audit when SQL statement is successfully performed by using the database privilege.

It does not create an audit record which is based on the privilege auditing about sys user (the database owner).

The database privilege which can be listed for the privilege auditing can be viewed through **V\$AUDITABLE\_DB\_PRIVILEGES** view.

```
SELECT privilege_name FROM v$auditable_db_privileges;
PRIVILEGE_NAME
-----
ADMINISTRATION
ALTER DATABASE
ALTER SYSTEM
ACCESS CONTROL
CREATE USER
ALTER USER
DROP USER
CREATE TABLESPACE
ALTER TABLESPACE
DROP TABLESPACE
USAGE TABLESPACE
CREATE SCHEMA
DROP SCHEMA
ANALYZE ANY
CREATE ANY TABLE
```

```
ALTER ANY TABLE
DROP ANY TABLE
SELECT ANY TABLE
INSERT ANY TABLE
DELETE ANY TABLE
UPDATE ANY TABLE
LOCK ANY TABLE
CREATE ANY VIEW
DROP ANY VIEW
CREATE ANY SEQUENCE
ALTER ANY SEQUENCE
DROP ANY SEQUENCE
USAGE ANY SEQUENCE
CREATE ANY INDEX
ALTER ANY INDEX
DROP ANY INDEX
CREATE ANY SYNONYM
DROP ANY SYNONYM
CREATE PUBLIC SYNONYM
DROP PUBLIC SYNONYM
CREATE PROFILE
ALTER PROFILE
DROP PROFILE
CREATE ANY PROCEDURE
ALTER ANY PROCEDURE
DROP ANY PROCEDURE
EXECUTE ANY PROCEDURE
AUDIT SYSTEM
PURGE DBA_RECYCLEBIN
44 rows selected.
```

The following is an example of when a user u1 who has SELECT ANY TABLE privilege activates an audit policy for the privilege auditing.

```
CREATE AUDIT POLICY p1
    PRIVILEGES SELECT ANY TABLE;
AUDIT POLICY p1;
```

Whether the audit record is created when a user u1 performs the following two statements is as follows.

- SELECT \* FROM u1.t1
  - It does not use SELECT ANY TABLE privilege because it is an owner of the object.

- An audit record does not exist.
- `SELECT * FROM other.t1`
  - It succeeds with `SELECT ANY TABLE` privilege even though it does not have `SELECT ON other.t1` privilege.
  - It creates an audit record.

Use `AUDIT_POLICY_OPTIONS` view to view the privilege auditing information as follows.

```
SELECT audit_option
       , audit_option_type
       , object_schema
       , object_name
FROM audit_policy_options
WHERE policy_name = 'P1'
;
```

| AUDIT_OPTION     | AUDIT_OPTION_TYPE  | OBJECT_SCHEMA | OBJECT_NAME |
|------------------|--------------------|---------------|-------------|
| SELECT ANY TABLE | DATABASE PRIVILEGE | null          | null        |

## Auditing Object Action

It audits SQL which is performed for a specific object.

Actions to be audited per each object type are as follows.

**Table 13-9** Audit action per object type

| Object type                   | Actions                                                                    |
|-------------------------------|----------------------------------------------------------------------------|
| Table                         | ALTER, COMMENT, DELETE, GRANT, INDEX, INSERT, LOCK, RENAME, SELECT, UPDATE |
| View                          | ALTER, COMMENT, GRANT, SELECT                                              |
| Sequence                      | ALTER, COMMENT, GRANT, SELECT                                              |
| Stored function/<br>procedure | ALTER, COMMENT, EXECUTE, GRANT                                             |

Create the audit policy as follows to audit DML for table `u1.t1`.

```
CREATE AUDIT POLICY audit_t1_dml
  ACTIONS INSERT ON u1.t1
         , DELETE ON u1.t1
         , UPDATE ON u1.t1
;
```

Execute `AUDIT_POLICY_OPTIONS` view as follows to view the information about object action auditing.

```

SELECT audit_option
       , audit_option_type
       , object_schema
       , object_name
  FROM audit_policy_options
 WHERE policy_name = 'AUDIT_T1_DML'
 ORDER BY audit_option
;

```

| AUDIT_OPTION | AUDIT_OPTION_TYPE | OBJECT_SCHEMA | OBJECT_NAME |
|--------------|-------------------|---------------|-------------|
| DELETE       | OBJECT ACTION     | U1            | T1          |
| INSERT       | OBJECT ACTION     | U1            | T1          |
| UPDATE       | OBJECT ACTION     | U1            | T1          |

3 rows selected.

ALL option such as ALL ON schema.object means all audit actions which can be defined for the corresponding object.

The following is an example of using ALL option together with other options.

```

CREATE AUDIT POLICY p1
      ACTIONS ALL ON u1.seq1
           , ALTER ON u1.seq1
;

```

Audit policy created.

```

SELECT audit_option
       , audit_option_type
       , object_schema
       , object_name
  FROM audit_policy_options
 WHERE policy_name = 'P1'
 ORDER BY audit_option
;

```

| AUDIT_OPTION | AUDIT_OPTION_TYPE | OBJECT_SCHEMA | OBJECT_NAME |
|--------------|-------------------|---------------|-------------|
| ALL          | OBJECT ACTION     | U1            | SEQ1        |
| ALTER        | OBJECT ACTION     | U1            | SEQ1        |

2 rows selected.

When dropping ALL option as follows, not every audit options are dropped, but only ALL option is dropped.



```

ALTER AUDIT POLICY p1
    DROP ACTIONS ALL ON u1.seq1;
Audit Policy altered.
SELECT audit_option
       , audit_option_type
       , object_schema
       , object_name
  FROM audit_policy_options
 WHERE policy_name = 'P1'
 ORDER BY audit_option;
AUDIT_OPTION AUDIT_OPTION_TYPE OBJECT_SCHEMA OBJECT_NAME
-----
ALTER        OBJECT ACTION      U1          SEQ1
1 row selected.

```

Auditing success or failure of EXECUTE a stored function or a stored procedure is determined based only on whether it is executable at the time of the execution.

- WHENEVER NOT SUCCESSFUL creates an audit record when it can not performs a stored function/ procedure.
- WHENEVER SUCCESSFUL creates an audit record even when an error occurs while performing an SQL statement in a stored function/ procedure.
- If an auditing the failure of an SQL statement in a stored function/ procedure, then that SQL statement should be included in an auditing target.

The following is an example of executing SELECT statement including a stored function.

```

SELECT others.func1( t1.c1 )
  FROM t1;

```

It corresponds to WHENEVER NOT SUCCESSFUL when it fails to call others.func1() due to an error such as a lack of privilege. It corresponds to WHENEVER SUCCESSFUL even though an error occurs while executing an SQL statement in a stored function when it succeeds to call others.func1().

## Auditing System Action

It audits an SQL statement regardless of a specific object.

A valid system action enquires V\$AUDITABLE\_SYSTEM\_ACTIONS.

```

SELECT action_name FROM v$auditable_system_actions;
ACTION_NAME
-----
ALL

```

DDL  
SELECT  
INSERT  
UPDATE  
DELETE  
EXECUTE  
CREATE TABLE  
DROP TABLE  
ALTER TABLE  
LOCK TABLE  
TRUNCATE TABLE  
ANALYZE TABLE  
RENAME  
CREATE INDEX  
DROP INDEX  
ALTER INDEX  
CREATE SEQUENCE  
DROP SEQUENCE  
ALTER SEQUENCE  
GRANT  
REVOKE  
CREATE SYNONYM  
DROP SYNONYM  
CREATE VIEW  
DROP VIEW  
ALTER VIEW  
CREATE PROCEDURE  
DROP PROCEDURE  
ALTER PROCEDURE  
CREATE FUNCTION  
DROP FUNCTION  
ALTER FUNCTION  
COMMENT  
ALTER DATABASE  
CREATE PROFILE  
DROP PROFILE  
ALTER PROFILE  
CREATE TABLESPACE  
DROP TABLESPACE  
ALTER TABLESPACE  
CREATE USER

```

DROP USER
ALTER USER
CHANGE PASSWORD
CREATE SCHEMA
DROP SCHEMA
CREATE AUDIT POLICY
DROP AUDIT POLICY
ALTER AUDIT POLICY
AUDIT
NOAUDIT
ALTER SYSTEM
ALTER SESSION
ANALYZE SYSTEM
COMMIT
ROLLBACK
SAVEPOINT
LOGON
LOGOFF
SET SESSION
SET TRANSACTION
SET CONSTRAINTS
CREATE CLUSTER GROUP
DROP CLUSTER GROUP
ALTER CLUSTER GROUP
CREATE CLUSTER LOCATION
DROP CLUSTER LOCATION
ALTER CLUSTER LOCATION
PURGE CONSTRAINT
PURGE INDEX
PURGE TABLE
PURGE TABLESPACE
PURGE RECYCLEBIN
PURGE DBA_RECYCLEBIN
FLASHBACK TABLE
76 rows selected.

```

A system action name corresponding to each SQL statement is viewed by executing `V$SQL_COMMAND` view.

```

SELECT command, audit_action FROM v$sql_command;
COMMAND                                AUDIT_ACTION

```

```

ALTER AUDIT POLICY
ALTER CLUSTER GROUP .. ADD CLUSTER MEMBER
ALTER CLUSTER GROUP .. OFFLINE CLUSTER MEMBER
ALTER DATABASE DROP INACTIVE CLUSTER MEMBERS
ALTER DATABASE OFFLINE INACTIVE CLUSTER MEMBERS
... Ellipsis ...
DROP CLUSTER LOCATION
PROCEDURAL LANGUAGE BLOCK
PURGE CONSTRAINT
PURGE INDEX
PURGE TABLE
PURGE TABLESPACE
PURGE RECYCLEBIN
PURGE DBA_RECYCLEBIN
FLASHBACK TABLE
185 rows selected.

```

The following is an example of creating an audit policy including a system action, and enquiring an audit option.

```

CREATE AUDIT POLICY p1
  ACTIONS SELECT
    , DROP TABLE
    , DROP USER
;
Audit Policy created.
SELECT audit_option
       , audit_option_type
       , object_schema
       , object_name
  FROM audit_policy_options
 WHERE policy_name = 'P1'
 ORDER BY audit_option
;

```

| AUDIT_OPTION | AUDIT_OPTION_TYPE | OBJECT_SCHEMA | OBJECT_NAME |
|--------------|-------------------|---------------|-------------|
| DROP TABLE   | SYSTEM ACTION     | null          | null        |
| DROP USER    | SYSTEM ACTION     | null          | null        |
| SELECT       | SYSTEM ACTION     | null          | null        |

3 rows selected.

## Useful Audit Policy

The following is an example of defining a useful audit policy.

- Auditing a logon failure

```
CREATE AUDIT POLICY AUDIT_LOGON_FAILURES
    ACTIONS LOGON
;
AUDIT POLICY AUDIT_LOGON_FAILURES
    WHENEVER NOT SUCCESSFUL
;
```

- Auditing a Data Definition Language (DDL) performance

```
CREATE AUDIT POLICY AUDIT_DDL
    ACTIONS DDL
;
AUDIT POLICY AUDIT_DDL
    WHENEVER SUCCESSFUL
;
```

- Auditing a parameter alteration

```
CREATE AUDIT POLICY AUDIT_DATABASE_PARAMETER
    ACTIONS ALTER DATABASE
        , ALTER SYSTEM
;
AUDIT POLICY AUDIT_DATABASE_PARAMETER
    WHENEVER SUCCESSFUL
;
```

- Auditing an account alteration

```
CREATE AUDIT POLICY AUDIT_ACCOUNT_MGMT
    ACTIONS CREATE USER
        , DROP USER
        , ALTER USER
        , CHANGE PASSWORD
        , GRANT
        , REVOKE
;
AUDIT POLICY AUDIT_ACCOUNT_MGMT
```

;

- Auditing the recommendations of Center for Internet Security (CIS)

```

CREATE AUDIT POLICY AUDIT_CIS_RECOMMENDATIONS
  PRIVILEGES ALTER SYSTEM
    , ALTER DATABASE
  ACTIONS CREATE USER
    , DROP USER
    , ALTER USER
    , CHANGE PASSWORD
    , GRANT
    , REVOKE
    , CREATE PROFILE
    , ALTER PROFILE
    , DROP PROFILE
    , CREATE SYNONYM
    , DROP SYNONYM
    , CREATE PROCEDURE
    , DROP PROCEDURE
    , ALTER PROCEDURE
;
AUDIT POLICY AUDIT_CIS_RECOMMENDATIONS
  WHENEVER SUCCESSFUL
;

```

## Operating Audit Policy

### Activating Audit Policy

An audit policy object does not start auditing until it is activated.

An audit policy object should be activated by using AUDIT POLICY statement as follows to perform auditing.

```

CREATE AUDIT POLICY audit_t1_dm1
  ACTIONS INSERT ON u1.t1
    , DELETE ON u1.t1
    , UPDATE ON u1.t1
;
Audit policy created.
AUDIT POLICY audit_t1_dm1;

```

Audit succeeded.

When activating an audit policy, it audits new sessions only, but it does not affect the existing sessions.

When activating an audit policy by using AUDIT POLICY statement, it can specify a user which will audit using BY clause or EXCEPT clause, or it may audit success/ failure of an audit action by using WHENEVER clause.

- BY | EXCEPT
  - BY user\_list: It specifies a user to audit.
  - EXCEPT user\_list: It audits all users except for specified users.
  - When it is omitted, it audits all users.
- WHENEVER
  - WHENEVER SUCCESSFUL: It creates an audit record when an audit action succeeds.
  - WHENEVER NOT SUCCESSFUL: It creates an audit record when an audit action fails.
  - When it is omitted, it creates an audit record regardless of a success/ failure of an audit action.

The information about activated audit policy can be viewed by executing AUDIT\_POLICY\_ENABLED view.

```
SELECT policy_name
       , enabled_opt
       , user_name
       , when_success
       , when_failure
FROM   audit_policy_enabled
WHERE  policy_name = 'AUDIT_T1_DML'
;
POLICY_NAME  ENABLED_OPT  USER_NAME  WHEN_SUCCESS  WHEN_FAILURE
-----
AUDIT_T1_DML BY          ALL USERS  YES           YES
```

If the auditing target user is omitted as the example above, it outputs ALL USERS meaning all users.

Note the followings when using BY clause and EXCEPT clause.

- BY clause and EXCEPT clause can not be used together for the same audit policy.

```
AUDIT POLICY audit_t1_dm1 BY u1;
Audit succeeded.
AUDIT POLICY audit_t1_dm1 EXCEPT u2;
ERR-42000(16475): audit policy already applied with the BY clause
```

- If multiple AUDIT POLICY BY clauses are used in the same audit policy, it is activated for the user sets.

In other words, the following examples have the same meaning.

- Example 1

```
AUDIT POLICY audit_t1_dml BY u1;
Audit succeeded.
AUDIT POLICY audit_t1_dml BY u2;
Audit succeeded.
SELECT policy_name
       , enabled_opt
       , user_name
       , when_success
       , when_failure
  FROM audit_policy_enabled
 WHERE policy_name = 'AUDIT_T1_DML'
;
POLICY_NAME  ENABLED_OPT  USER_NAME  WHEN_SUCCESS  WHEN_FAILURE
-----
AUDIT_T1_DML BY          U1          YES          YES
AUDIT_T1_DML BY          U2          YES          YES
2 rows selected.
```

- Example 2

```
AUDIT POLICY audit_t1_dml BY u1, u2;
Audit succeeded.
SELECT policy_name
       , enabled_opt
       , user_name
       , when_success
       , when_failure
  FROM audit_policy_enabled
 WHERE policy_name = 'AUDIT_T1_DML'
;
POLICY_NAME  ENABLED_OPT  USER_NAME  WHEN_SUCCESS  WHEN_FAILURE
-----
AUDIT_T1_DML BY          U1          YES          YES
AUDIT_T1_DML BY          U2          YES          YES
2 rows selected.
```

- If multiple AUDIT POLICY EXCEPT clauses are used in the same audit policy, only the last AUDIT POLICY statement is valid. In other words, the following examples have different meanings.



- Example 1

```
AUDIT POLICY audit_t1_dml EXCEPT u1;
Audit succeeded.
AUDIT POLICY audit_t1_dml EXCEPT u2;
Audit succeeded.
SELECT policy_name
       , enabled_opt
       , user_name
       , when_success
       , when_failure
FROM audit_policy_enabled
WHERE policy_name = 'AUDIT_T1_DML'
;
POLICY_NAME  ENABLED_OPT  USER_NAME  WHEN_SUCCESS  WHEN_FAILURE
-----
AUDIT_T1_DML EXCEPT      U2          YES           YES
1 row selected.
```

- Example 2

```
AUDIT POLICY audit_t1_dml EXCEPT u1, u2;
Audit succeeded.
SELECT policy_name
       , enabled_opt
       , user_name
       , when_success
       , when_failure
FROM audit_policy_enabled
WHERE policy_name = 'AUDIT_T1_DML'
;
POLICY_NAME  ENABLED_OPT  USER_NAME  WHEN_SUCCESS  WHEN_FAILURE
-----
AUDIT_T1_DML EXCEPT      U1          YES           YES
AUDIT_T1_DML EXCEPT      U2          YES           YES
2 rows selected.
```

- WHENEVER clause which is used together with BY clause is accumulated. In other words, the following examples have the same meaning.

- Example 1

```
AUDIT POLICY audit_t1_dml BY u1 WHENEVER SUCCESSFUL;
```

```
Audit succeeded.
```

```
SELECT policy_name
       , enabled_opt
       , user_name
       , when_success
       , when_failure
FROM   audit_policy_enabled
WHERE  policy_name = 'AUDIT_T1_DML'
;
POLICY_NAME  ENABLED_OPT  USER_NAME  WHEN_SUCCESS  WHEN_FAILURE
-----
```

```
AUDIT_T1_DML BY          U1          YES          NO
```

```
1 row selected.
```

```
AUDIT POLICY audit_t1_dml BY u1 WHENEVER NOT SUCCESSFUL;
```

```
Audit succeeded.
```

```
SELECT policy_name
       , enabled_opt
       , user_name
       , when_success
       , when_failure
FROM   audit_policy_enabled
WHERE  policy_name = 'AUDIT_T1_DML'
;
POLICY_NAME  ENABLED_OPT  USER_NAME  WHEN_SUCCESS  WHEN_FAILURE
-----
```

```
AUDIT_T1_DML BY          U1          YES          YES
```

```
1 row selected.
```

- Example 2

```
AUDIT POLICY audit_t1_dml BY u1;
```

```
Audit succeeded.
```

```
SELECT policy_name
       , enabled_opt
       , user_name
       , when_success
       , when_failure
FROM   audit_policy_enabled
WHERE  policy_name = 'AUDIT_T1_DML'
;
```

```

POLICY_NAME  ENABLED_OPT  USER_NAME  WHEN_SUCCESS  WHEN_FAILURE
-----
AUDIT_T1_DML BY          U1          YES          YES
1 row selected.

```

- If WHENEVER clause is used together with EXCEPT clause, then only the last part of it is valid. In other words, the following examples have different meanings.
  - Example 1

```

AUDIT POLICY audit_t1_dml EXCEPT u1 WHENEVER SUCCESSFUL;
Audit succeeded.
AUDIT POLICY audit_t1_dml EXCEPT u1 WHENEVER NOT SUCCESSFUL;
Audit succeeded.
SELECT policy_name
       , enabled_opt
       , user_name
       , when_success
       , when_failure
FROM   audit_policy_enabled
WHERE  policy_name = 'AUDIT_T1_DML'
;
POLICY_NAME  ENABLED_OPT  USER_NAME  WHEN_SUCCESS  WHEN_FAILURE
-----
AUDIT_T1_DML EXCEPT    U1          NO          YES
1 row selected.

```

- Example 2

```

AUDIT POLICY audit_t1_dml EXCEPT u1;
Audit succeeded.
SELECT policy_name
       , enabled_opt
       , user_name
       , when_success
       , when_failure
FROM   audit_policy_enabled
WHERE  policy_name = 'AUDIT_T1_DML'
;
POLICY_NAME  ENABLED_OPT  USER_NAME  WHEN_SUCCESS  WHEN_FAILURE
-----
AUDIT_T1_DML EXCEPT    U1          YES         YES

```

1 row selected.

## Deactivating Audit Policy

NOAUDIT POLICY statement should be executed to deactivate an audit policy.

NOAUDIT POLICY statement is applied only to a new session, and it does not affect to the existing session.

If all information is set to be deactivated by using the query below, then an audit policy is completely deactivated.

```
SELECT policy_name
       , enabled_opt
       , user_name
       , when_success
       , when_failure
FROM   audit_policy_enabled
WHERE  policy_name = 'AUDIT_T1_DML'
;
no rows selected.
```

NOAUDIT POLICY statement deletes each activated information which is created according to the specified AUDIT POLICY method.

The following is an example of deactivating only the auditing for u1 user of audit\_t1\_dml.

```
SELECT policy_name
       , enabled_opt
       , user_name
       , when_success
       , when_failure
FROM   audit_policy_enabled
WHERE  policy_name = 'AUDIT_T1_DML'
;
POLICY_NAME  ENABLED_OPT  USER_NAME  WHEN_SUCCESS  WHEN_FAILURE
-----
AUDIT_T1_DML BY          U1          YES          YES
AUDIT_T1_DML BY          SYS         YES          YES
2 rows selected.
NOAUDIT POLICY audit_t1_dml BY u1;
Noaudit succeeded.
SELECT policy_name
```

```

, enabled_opt
, user_name
, when_success
, when_failure
FROM audit_policy_enabled
WHERE policy_name = 'AUDIT_T1_DML'
;
POLICY_NAME  ENABLED_OPT  USER_NAME  WHEN_SUCCESS  WHEN_FAILURE
-----
AUDIT_T1_DML BY          SYS          YES          YES
1 row selected.

```

If AUDIT POLICY name BY clause is used it should be deactivated by using NOAUDIT POLICY name BY statement. If AUDIT POLICY name EXCEPT clause is used it should be deactivated by using NOAUDIT POLICY name statement without BY clause.

NOAUDIT POLICY statement should be used according to the usage as follows to deactivate each option of AUDIT POLICY statement.

**Table 13-10** Activating/ deactivating audit policy

| Type         | AUDIT POLICY statement    | NOAUDIT POLICY statement |
|--------------|---------------------------|--------------------------|
| All users    | AUDIT POLICY p1           | NOAUDIT POLICY p1        |
| Using BY     | AUDIT POLICY p1 BY u1     | NOAUDIT POLICY p1 BY u1  |
| Using EXCEPT | AUDIT POLICY p1 EXCEPT u1 | NOAUDIT POLICY p1        |

If all users are activated as follows, NOAUDIT POLICY BY clause does not affect anything.

```

AUDIT POLICY audit_t1_dml;
Audit succeeded.
SELECT policy_name
, enabled_opt
, user_name
, when_success
, when_failure
FROM audit_policy_enabled
WHERE policy_name = 'AUDIT_T1_DML'
;
POLICY_NAME  ENABLED_OPT  USER_NAME  WHEN_SUCCESS  WHEN_FAILURE
-----
AUDIT_T1_DML BY          ALL USERS  YES          YES
1 row selected.
NOAUDIT POLICY audit_t1_dml BY u1;

```

```

Noaudit succeeded.
SELECT policy_name
       , enabled_opt
       , user_name
       , when_success
       , when_failure
FROM   audit_policy_enabled
WHERE  policy_name = 'AUDIT_T1_DML'
;
POLICY_NAME  ENABLED_OPT  USER_NAME  WHEN_SUCCESS  WHEN_FAILURE
-----
AUDIT_T1_DML BY          ALL USERS  YES           YES
1 row selected.

```

If one or more users are separately activated, NOAUDIT POLICY statement should be used according to the AUDIT POLICY configuration.

- When it is activated by using BY clause
  - The following is an example of activating by using BY clause.

```

AUDIT POLICY p1 WHENEVER NOT SUCCESSFUL;
AUDIT POLICY p1 BY u1;
AUDIT POLICY p1 BY u2;

```

- The information about activating is viewed as follows.

```

SELECT policy_name
       , enabled_opt
       , user_name
       , when_success
       , when_failure
FROM   audit_policy_enabled
WHERE  policy_name = 'P1';
POLICY_NAME  ENABLED_OPT  USER_NAME  WHEN_SUCCESS  WHEN_FAILURE
-----
P1           BY          ALL USERS  NO            YES
P1           BY          U1         YES           YES
P1           BY          U2         YES           YES
3 rows selected.

```

- The following is the information about activating when NOAUDIT statement is performed.

```
NOAUDIT POLICY p1;
Noaudit succeeded.
SELECT policy_name
       , enabled_opt
       , user_name
       , when_success
       , when_failure
  FROM audit_policy_enabled
 WHERE policy_name = 'P1';
POLICY_NAME ENABLED_OPT USER_NAME WHEN_SUCCESS WHEN_FAILURE
-----
P1          BY          U1          YES          YES
P1          BY          U2          YES          YES
2 rows selected.
```

In the example above, the auditing for ALL USERS is deactivated, but the auditing for user u1 and u2 are still activated.

If NOAUDIT POLICY statement is used again by using BY option as follows, then it completely deactivate t he audit policy p1.

```
NOAUDIT POLICY p1 BY u1, u2;
Noaudit succeeded.
SELECT policy_name
       , enabled_opt
       , user_name
       , when_success
       , when_failure
  FROM audit_policy_enabled
 WHERE policy_name = 'P1';
no rows selected.
```

- When it is activated by using EXCEPT
  - The following is an example of activating by using the audit policy.

```
AUDIT POLICY p1 EXCEPT u1, sys;
```

- The information about activating is viewed as follows.

```
SELECT policy_name
       , enabled_opt
```

```

, user_name
, when_success
, when_failure
FROM audit_policy_enabled
WHERE policy_name = 'P1';
POLICY_NAME ENABLED_OPT USER_NAME WHEN_SUCCESS WHEN_FAILURE
-----
P1          EXCEPT   U1          YES          YES
P1          EXCEPT   SYS         YES          YES
2 rows selected.

```

- Unlike AUDIT POLICY statement, NOAUDIT POLICY statement does not have an EXCEPT option, and it executes the statement without an option as follows.

```

NOAUDIT POLICY p1;
Noaudit succeeded.
SELECT policy_name
, enabled_opt
, user_name
, when_success
, when_failure
FROM audit_policy_enabled
WHERE policy_name = 'P1';
no rows selected.

```

In other words, if an audit policy is activated by using an EXCEPT option, then a separate user can not be re activated by using NOAUDIT POLICY statement.



## 13.4 Authorization

### Authorization-related Statements

For more information, refer to the followings.

- Creating a user: **CREATE USER**
- Dropping a user: **DROP USER**
- Altering a user: **ALTER USER**
  
- Granting privileges: **GRANT privileges TO**
- Revoking privileges: **REVOKE privileges FROM**

Information related to a user object and the authorization can be retrieved through the following views.

**Table 13-11** Authorization objects related information

| Schema | View                  | Description                                                            |
|--------|-----------------------|------------------------------------------------------------------------|
|        | ALL_COL_PRIVS         | Privileges for the user-accessible column                              |
|        | ALL_COL_PRIVS_MADE    | Privileges for the column whose user is the grantor                    |
|        | ALL_COL_PRIVS_RECD    | Privileges for the column whose user is the grantee                    |
|        | ALL_DB_PRIVS          | DB privileges which is related to a user                               |
|        | ALL_DB_PRIVS_MADE     | Privileges for the DB whose user is the grantor                        |
|        | ALL_DB_PRIVS_RECD     | Privileges for the DB whose user is the grantee                        |
|        | ALL_PROC_PRIVS        | Stored procedure/function privileges which is related to a user        |
|        | ALL_PROC_PRIVS_MADE   | Privileges for the stored procedure/function whose user is the grantor |
|        | ALL_PROC_PRIVS_RECD   | Privileges for the stored procedure/function whose user is the grantee |
|        | ALL_SCHEMA_PRIVS      | Privileges for the user-accessible schema                              |
|        | ALL_SCHEMA_PRIVS_MADE | Privileges for the schema whose user is the grantor                    |
|        | ALL_SCHEMA_PRIVS_RECD | Privileges for the schema whose user is the grantee                    |
|        | ALL_SEQ_PRIVS         | Privileges for the user-accessible sequence                            |
|        | ALL_SEQ_PRIVS_MADE    | Privileges for the sequence whose user is the grantor                  |
|        | ALL_SEQ_PRIVS_RECD    | Privileges for the sequence whose user is the grantee                  |
|        | ALL_TAB_PRIVS         | Privileges for the user-accessible table                               |
|        | ALL_TAB_PRIVS_MADE    | Privileges for the table whose user is the grantor                     |
|        | ALL_TAB_PRIVS_RECD    | Privileges for the table whose user is the grantee                     |
|        | ALL_TBS_PRIVS         | Privileges for the user-accessible tablespace                          |

| Schema             | View                   | Description                                                                       |
|--------------------|------------------------|-----------------------------------------------------------------------------------|
| DICTIONARY_SCHEMA  | ALL_TBS_PRIVS_MADE     | Privileges for the tablespace whose user is the grantor                           |
|                    | ALL_TBS_PRIVS_RECD     | Privileges for the tablespace whose user is the grantee                           |
|                    | ALL_USERS              | Information about the user-accessible user                                        |
|                    | USER_COL_PRIVS         | Privilege information about the user owned column                                 |
|                    | USER_COL_PRIVS_MADE    | Information of granting privileges about the user owned column                    |
|                    | USER_COL_PRIVS_RECD    | Information of acquiring privilege about the user owned column                    |
|                    | USER_PROC_PRIVS        | Privilege information about the user owned stored procedure/function              |
|                    | USER_PROC_PRIVS_MADE   | Information of granting privileges about the user owned stored procedure/function |
|                    | USER_PROC_PRIVS_RECD   | Information of acquiring privilege about the user owned stored procedure/function |
|                    | USER_SCHEMA_PRIVS      | Privilege information about the user owned schema                                 |
|                    | USER_SCHEMA_PRIVS_MADE | Information of granting privileges about the user owned schema                    |
|                    | USER_SCHEMA_PRIVS_RECD | Information of acquiring privilege about the user owned schema                    |
|                    | USER_SEQ_PRIVS         | Privilege information about the user owned sequence                               |
|                    | USER_SEQ_PRIVS_MADE    | Information of granting privileges about the user owned sequence                  |
|                    | USER_SEQ_PRIVS_RECD    | Information of acquiring privilege about the user owned sequence                  |
|                    | USER_TAB_PRIVS         | Privileges information about the user owned table                                 |
|                    | USER_TAB_PRIVS_MADE    | Information of granting privileges about the user owned table                     |
|                    | USER_TAB_PRIVS_RECD    | Information of acquiring privilege about the user owned table                     |
|                    | USER_USERS             | Information about the current user                                                |
|                    | INFORMATION_SCHEMA     | COLUMN_PRIVILEGES                                                                 |
| ROUTINE_PRIVILEGES |                        | Privilege information of user-accessible stored procedure/function                |
| TABLE_PRIVILEGES   |                        | Privilege information of user-accessible table                                    |
| USAGE_PRIVILEGES   |                        | Privilege information of user-accessible sequence                                 |

## Concepts of User

A user object consists of the user's execution privilege set. The user should have the appropriate privilege to execute the SQL statements for the corresponding object.

For example, the user which is created by using **CREATE USER** statement is an object without any privileges. The user can not access the database nor does it execute any SQL statement. For access, the user should have **CREATE SESSION ON DATABASE** privilege which allows creating sessions in database object. The appropriate privilege should be granted after executing **CREATE USER** statement as follows.

```
CREATE USER u1 IDENTIFIED BY u1_password;  
GRANT CREATE SESSION ON DATABASE TO u1;  
COMMIT;
```

For more information about granting privilege after creating user object, refer to **Examples in CREATE USER and GRANT privileges TO**.

## Creating Objects and Privileges

### Creating SQL Schema Object

When creating an SQL schema object such as a table, the user should have the privileges for the superordinate non-schema object to which the table belongs in order to execute **CREATE TABLE** statements.

The following is an example of **CREATE TABLE** statements.

```
CREATE TABLE t1 ( id BIGINT, name VARCHAR(128) );
```

When it is interpreted as follows,

```
CREATE TABLE u1.t1 ( id BIGINT, name VARCHAR(128) ) TABLESPACE mem_data_tbs;
```

In the figure below, the owner of the table t1 is the account u1 who is the owner of the schema u1. The schema u1 is the logical location which includes the table, and the table space mem\_data\_tbs is the physical storage which stores the table.

Figure 2 CREATE TABLE and non-schema objects

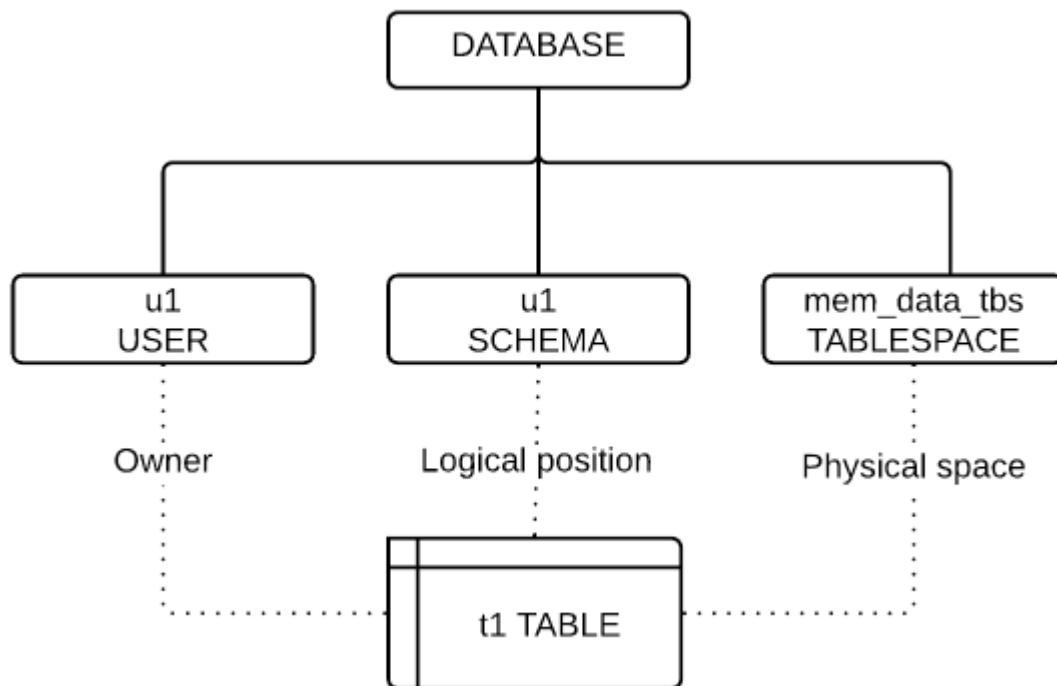

In this case, the user u1 who performed the statement needs the following privileges for the schema and tablespace to which the table t1 will belong.

One of the following privileges is required to create the table which will be stored on its logical location (schema u1).

- Privilege to create the table on the schema u1
  - CREATE TABLE ON SCHEMA ON u1
- Privilege to create any table on the database
  - CREATE ANY TABLE ON DATABASE
  - A table can be created when having privileges for the database which is superordinate object of the schema u1 even without the schema privilege.

One of the following privileges is required to create a table in tablespace mem\_data\_tbs which is the physical storage space of tables.

- Privilege to create an object on the tablespace mem\_data\_tbs
  - CREATE OBJECT ON TABLESPACE mem\_data\_tbs
- Privilege to use all tablespaces in the database
  - USAGE TABLESPACE ON DATABASE
  - A table can be created when having privileges for the database which is the superordinate object of mem\_data\_tbs tablespace even without the tablespace privilege.

The owner of the table object is determined as follows.

- The owner of the schema to which the table belongs
- If the owner of the schema to which the table belongs is PUBLIC, then it is the user who executed the statement.

The owner of the table object has the following privileges to change the table structure and manipulate data in the table.

- SELECT ON TABLE
  - The privilege to execute SELECT statement on the table
- INSERT ON TABLE
  - The privilege to execute INSERT statement on the table
- UPDATE ON TABLE
  - The privilege to execute UPDATE statement on the table
- DELETE ON TABLE
  - The privilege to execute DELETE statement on the table
- LOCK ON TABLE
  - The privilege to execute LOCK statement on the table
- INDEX ON TABLE
  - The privilege to execute CREATE/DROP/ALTER INDEX statement on the table
- ALTER ON TABLE
  - The privilege to execute ALTER TABLE statement on the table

The grantor of the given privilege is the `_SYSTEM` account which is used internally, and the grantee is the table owner. Therefore, any user including SYS account is not allowed to remove or change the owner privilege using **REVOKE privileges FROM**. The table owner's privileges are also removed when the table is removed.

## Creating Non-schema Object

As like creating the SQL schema object such as a table, the appropriate privileges for the database (a superordinate object) are required to create the non-schema objects such as user, schema, tablespace.

A user who executes the following statements should have the following privileges for the database object (a superordinate object) per each statement.

- CREATE USER statement
  - CREATE USER ON DATABASE
  - The privilege to execute CREATE USER statement on the database
- CREATE TABLESPACE statement
  - CREATE TABLESPACE ON DATABASE
  - The privilege to execute CREATE TABLESPACE statement on the database
- CREATE SCHEMA statement
  - CREATE SCHEMA ON DATABASE

- The privilege to execute CREATE SCHEMA statement on the database
- CREATE PUBLIC SYNONYM statement
  - The privilege to execute CREATE PUBLIC SYNONYM statement on the database

Unlike creating the SQL schema object, the user who performed CREATE statement is not the owner of non-schema object. Each object has the following characteristics.

- User object
  - There is not an owner.
  - DROP USER ON DATABASE privilege is required to drop a user object.
- Tablespace object
  - There is not an owner.
  - DROP TABLESPACE ON DATABASE privilege is required to drop a tablespace object.
- Schema object
  - It is an owner which is specified in the CREATE SCHEMA statement.
  - The schema object owner can drop it.
- Public synonym object
  - There is not an owner.
  - DROP PUBLIC SYNONYM ON DATABASE privilege is required to drop a public synonym object.

## Privileges

### Granting Privileges

To INSERT, DELETE, UPDATE, or SELECT data when the user is not the owner of SQL schema object such as table, then the user should be granted the appropriate privileges by using **GRANT privileges TO** statement.

For example, a user who is not the owner of the table requires one of the following privileges to execute SELECT statement. As the figure below, the user can query the u1.t1 table if the user has SELECT privileges on the superordinate object u1 schema or the database even when the user does not have SELECT privilege on table t1.

- The test user executes the following.

```
SELECT id, name FROM u1.t1 WHERE id < 100;
```

Figure 3 Privilege to execute SELECT statement

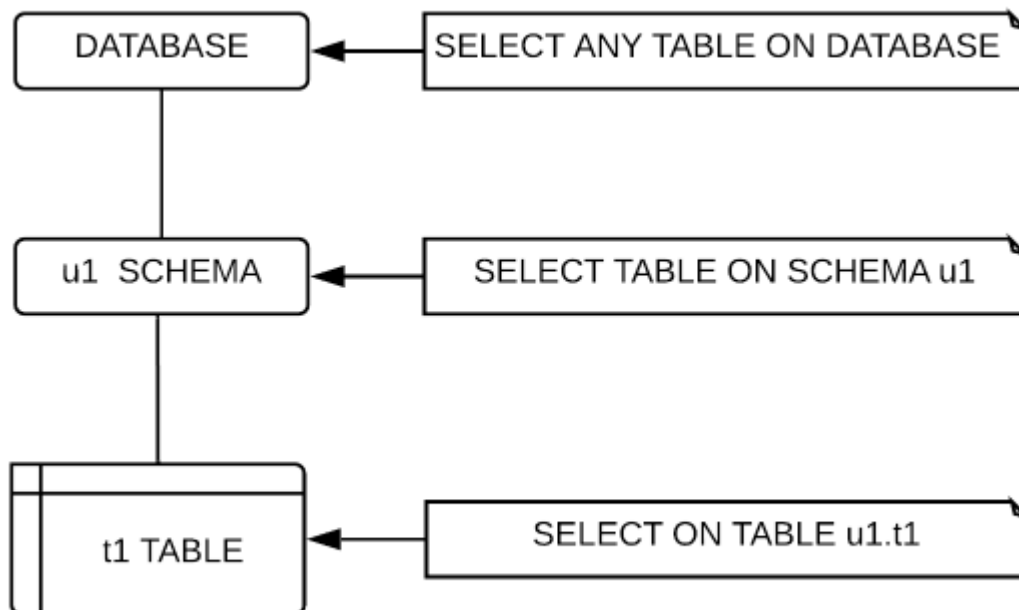

- SELECT ON TABLE u1.t1
  - SELECT privilege for the table u1.t1
- SELECT ON SCHEMA u1
  - SELECT privilege for the schema u1 which is the superordinate object
  - SELECT privilege for all tables of the schema u1
- SELECT ANY TABLE ON DATABASE
  - SELECT privilege for the database which is the second superordinate object
  - SELECT privilege for all tables of the database

The user who executed the GRANT statement should be one of the followings to grant the SELECT ON TABLE u1.t1 privileges to another user.

- Owner of the object u1.t1
  - The object owner has the privilege of SELECT ON TABLE u1.t1 WITH GRANT OPTION granted by the \_SYSTEM account.
- User with SELECT ON TABLE u1.t1 WITH GRANT OPTION
  - WITH GRANT OPTION enables the grantee to grant the granted privileges to another user.
- User with the privilege of ACCESS CONTROL ON DATABASE
  - The user can control all privileges on all objects.

The following is an example that the object owner grants privileges to another user.

- The owner of the table u1.t1 executes GRANT statement.

```
GRANT SELECT ON TABLE u1.t1 TO test;
```

For more information about the privilege types, refer to **GRANT privileges TO**.

For more information about privileges executing each SQL statements, refer to the Invocation and Access Rule of each statement in **SQL References** part.

## Revoking Privileges

The granted privileges are revoked from a user by using **REVOKE privileges FROM**. The privileges of the object's owner can not be revoked until the object is removed.

For example, a user who can execute REVOKE statement to revoke the SELECT privilege from the test user is as follows. The user can not revoke privileges which were not granted by the user even when the user is the owner of the table.

```
REVOKE SELECT ON TABLE u1.t1 FROM test;
```

- User who grants privileges
  - The user grants the privilege of SELECT ON TABLE u1.t1 to the test1 user.
- User who has the privilege of ACCESS CONTROL ON DATABASE
  - The user can control all privileges on all objects.

When the test user is granted the same privileges from multiple users as follows, the test user can execute SELECT statement until all the privileges are revoked.

- The object owner u1 grants the privilege to the test user.

```
GRANT SELECT ON TABLE u1.t1 TO test;
```

- The object owner u1 grants the privilege of WITH GRANT OPTION to the user u2.

```
GRANT SELECT ON TABLE u1.t1 TO u2 WITH GRANT OPTION;
```

- The user u2 executes it.
- The u2 user with the privilege of WITH GRANT OPTION grants the privilege to the test user.

```
GRANT SELECT ON TABLE u1.t1 TO test;
```

In the example above, the test user has two SELECT ON TABLE u1.t1 privileges which were granted by user u1 and user u2. The privilege information consists of {grantor, grantee, object privileges}.



## PUBLIC Account

PUBLIC account is a special account which means every user.

For example, if the SELECT privilege is granted to PUBLIC account as follows, every user can execute SELECT statements on the table, u1.t1.

```
GRANT SELECT ON TABLE u1.t1 TO PUBLIC;
```

Even a user without SELECT privilege can execute SELECT statements on the table u1.t1 using the SELECT privilege on PUBLIC account.

When a privilege is granted to PUBLIC account, it is granted not to the existing users but to PUBLIC account itself. Even the newly created user can also execute SELECT statements.

Likewise, the user can execute SELECT statements if the user has the SELECT privilege on the table u1.t1 because revoking a privilege from PUBLIC account does not mean revoking the privilege from every user.

- The privilege is granted to the test user.

```
GRANT SELECT ON TABLE u1.t1 TO test;
```

- The privilege is granted to PUBLIC account.

```
GRANT SELECT ON TABLE u1.t1 TO PUBLIC;
```

- The privilege is revoked from PUBLIC account, and the test user still has the privilege on SELECT ON TABLE u1.t1.

```
REVOKE SELECT ON TABLE u1.t1 FROM PUBLIC;
```

## Column Privilege

By granting privileges only on specific columns of a table, it is possible to control the execution of DML or SELECT statements of other user.

The following is an example table.

```
CREATE TABLE u1.t1
(
  id      BIGINT,
  name    VARCHAR(128),
  addr    VARCHAR(1024),
  salary  NUMBER(20,0)
);
```

If SELECT privilege on the table u1.t1 excluding the salary column information is granted to another user, **GRANT privileges TO** statement is executed by listing the columns to be grantees of the privilege as follows. The test user who is the grantees of the privilege can not query the salary column.

- The privilege on SELECT columns is granted to the test user.

```
GRANT SELECT( id, name, addr ) ON TABLE u1.t1 TO test;
```

If the privilege on a table is granted as follows, the privilege on every column in the table is automatically granted. If both table privilege and column privilege are granted, the privilege information for a column is duplicated and the information is not dually managed.

- SELECT privilege is granted to the test user.

```
GRANT SELECT ON TABLE u1.t1 TO test;
```

- Privileges on every column in the table u1.t1 are automatically granted.

```
GRANT SELECT(id) ON TABLE u1.t1 TO test;  
GRANT SELECT(name) ON TABLE u1.t1 TO test;  
GRANT SELECT(addr) ON TABLE u1.t1 TO test;  
GRANT SELECT(salary) ON TABLE u1.t1 TO test;
```

The privilege on a column is revoked by using **REVOKE privileges FROM** as follows.

- The privilege on SELECT columns is revoked from the test user.

```
REVOKE SELECT( id, name, addr ) ON TABLE u1.t1 FROM test;
```

If the privilege on a table is revoked as follows, the privilege on every column in the table is automatically revoked. Even if the column privileges and table privileges are separately granted, the columns privileges are revoked when the table privileges are revoked.

- SELECT privilege is revoked from the test user.
- Privileges on every column in the table u1.t1 are revoked.

```
REVOKE SELECT ON TABLE u1.t1 FROM test;
```

When revoking only the column privilege and the table privilege still exists as follows, then the following statements can be executed by using the table privilege. Therefore, to grant the privilege only on a specific column, the table privilege should be revoked, and then each column privilege should be granted.

- SELECT table privilege is granted to the test user.

```
GRANT SELECT ON TABLE u1.t1 TO test;
```

- The SELECT(salary) column privilege is revoked from the test user.
- The test user can query the salary column in the table u1.t1 because the test user has the SELECT privilege on the table.

```
REVOKE SELECT(salary) ON TABLE u1.t1 FROM test;
```

For more information about the privileges on a table and columns, refer to **GRANT privileges TO** .

## 13.5 Schema

### Schema-related Statements

For more information about creating and dropping a schema, refer to the followings.

- Creating a schema: **CREATE SCHEMA**.
- Dropping a schema: **DROP SCHEMA**.

Information which is related to a schema object can be retrieved through the following views.

**Table 13-12** Schema object-related information

| Schema             | View             | Description                        |
|--------------------|------------------|------------------------------------|
| DICTIONARY_SCHEMA  | ALL_SCHEMAS      | User accessible schema information |
|                    | ALL_SCHEMA_PATH  | User accessible schema path        |
|                    | USER_SCHEMAS     | User owned schema information      |
|                    | USER_SCHEMA_PATH | User's schema path information     |
| INFORMATION_SCHEMA | SCHEMATA         | User accessible schema information |

### Concepts of Schema

The database consists of one or more schemas. The schema consists of objects such as tables, indexes, views, and sequences, which processes data. SQL schema object is an object which belongs to the schema.

Schema is similar to the directory in OS. The relationship between schema and tables is similar to the relationship between the directories and files in OS.

Schema is the logical position of the SQL schema object and it is criteria of distinguishing the name. Every SQL schema object should have a unique name and the naming space in the schema is as follows.

- Table, view, sequence, private synonym, stored procedure, stored function
- Index
- Constraint

The same name tables can be defined in the different schema. The different tables with same name are accessible and executed by specifying together with the schema name.

```
gSQL> SELECT u1.t1.id, u1.t1.name, u2.t1.addr
        FROM u1.t1, u2.t1
        WHERE u1.t1.id = u2.t1.id;
```

The name of SQL schema object is specified together with the schema name or without it. If the schema name is omitted, it is determined by the user's schema path. For more information about the schema path, refer to **Schema Path** clause.

- When the schema name is specified

```
gSQL> SELECT u1.t1.id, u1.t1.name FROM u1.t1;
```

- When the schema name is omitted

```
gSQL> SELECT t1.id, t1.name FROM t1;
```

## User and Schema

In GOLDILOCKS, relationship between the user and the schema is 1:N. A user does not own a schema, or the user can have multiple schemas.

The SQL standard does not explicitly define the relationship of the non-schema objects such as user, schema, database. Each DBMS defines the relationship of the non-schema objects in different ways, and they are as follows.

- Oracle
  - The relationship between the user and the schema is 1:1.
- DB2
  - The relationship between the user and the schema is 1:N.
- Postgres
  - The relationship between the user and the schema is 1:N.
- MySQL
  - The relationship between the database and the schema is 1:1.
  - User is a subordinate object of the schema (database).

When establishing the database, GOLDILOCKS configures various relationships between the users and schemas in accordance with the characteristics of the client system as follows.

Figure 4 Relationship between user and schema

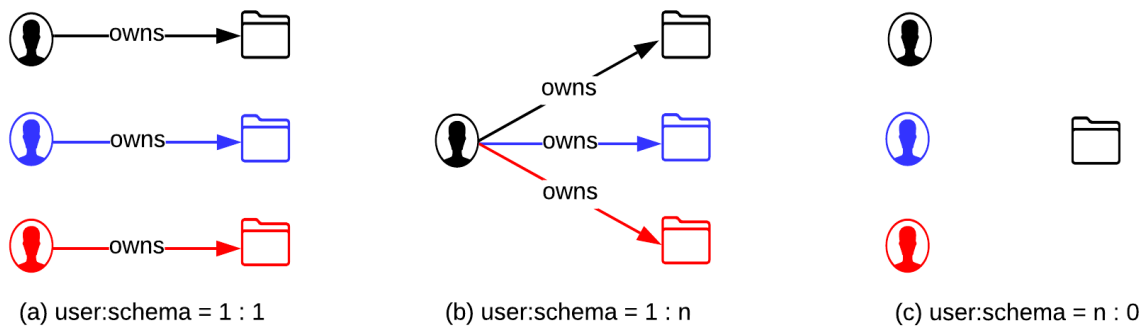

To configure the database in which each user has its own schema as shown in the figure (a), create the users and schemas as follows.

- Create a user and the schema u1 together so that the user owns the schema.

```
gSQL> CREATE USER u1 IDENTIFIED BY u1_password WITH SCHEMA;
```

- WITH SCHEMA statement is optional and a schema whose name is as same as the user is created.

```
gSQL> CREATE USER u2 IDENTIFIED BY u2_password;
gSQL> CREATE USER u3 IDENTIFIED BY u3_password;
```

To configure the database in which a single user has multiple schemas as shown in the figure (b), create the users and schemas as follows.

- Create the user u1 only without creating a schema.

```
gSQL> CREATE USER u1 IDENTIFIED BY u1_password WITHOUT SCHEMA;
```

- Create multiple schemas and specify the owner of each schema as a user u1.

```
gSQL> CREATE SCHEMA s1 AUTHORIZATION u1;
gSQL> CREATE SCHEMA s2 AUTHORIZATION u1;
gSQL> CREATE SCHEMA s3 AUTHORIZATION u1;
```

To configure the database in which multiple users share a single schema without creating a schema as shown in the figure (c), create users as follows.

All users share **PUBLIC Schema** in the following examples.

- Create users only without creating a schema.

```
gSQL> CREATE USER u1 IDENTIFIED BY u1_password WITHOUT SCHEMA;  
gSQL> CREATE USER u2 IDENTIFIED BY u2_password WITHOUT SCHEMA;  
gSQL> CREATE USER u3 IDENTIFIED BY u3_password WITHOUT SCHEMA;
```

For more information about creating user and schema, refer to **CREATE USER**, **CREATE SCHEMA**.

## Schema Path

Schema path is a path to find the schema name when the SQL schema object name such as a table is used without the schema name. Schema path is similar to the PATH environment variable of Unix system. It is similar in searching for a command in the PATH in the specified order when executing commands on Unix system.

When a user has multiple schemas, then creates or queries the table without a schema name as follows, the schema path determines in which schema the table will be created.

- A table t1 is created in the schema s1.

```
gSQL> CREATE TABLE s1.t1 ( id INTEGER );
```

- A table t1 is created in the schema s2.

```
gSQL> CREATE TABLE s2.t1 ( name VARCHAR(128) );
```

- In which schema the table t1 will be created?

```
gSQL> CREATE TABLE t1 ( address VARCHAR(1024) );
```

- Which schema's table t1 is retrieved?

```
gSQL> SELECT * FROM t1;
```

The figure below illustrates an example of a schema path for user u1. The schema path of user u1 is designated in an order of {s1, s2, s3}. Schema s1 has a table t1, schema s2 has a table t2, and the schema s3 has tables t1 and t3.

Figure 5 Example of schema path

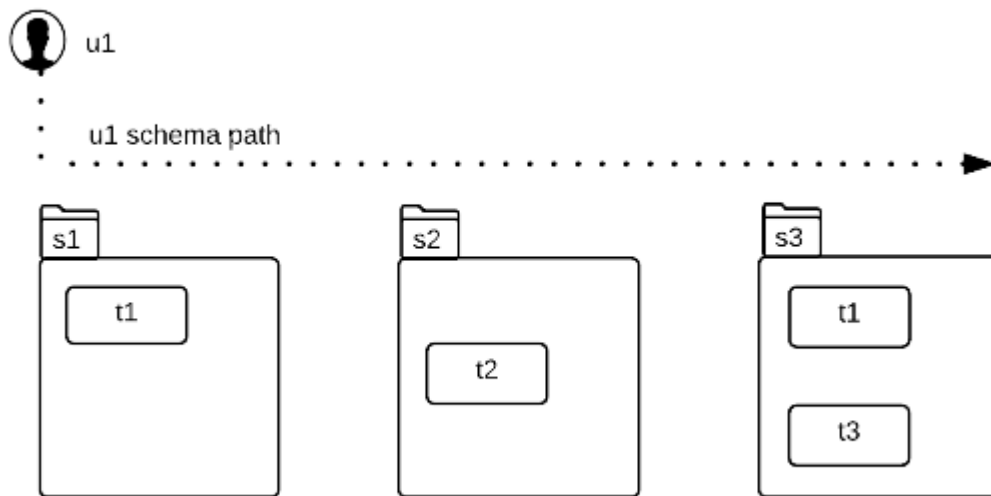

In the SELECT statement without the schema name, the schema name is construed by the schema path as follows.

- It is construed as table s1.t1 by the schema path.

```
gSQL> SELECT * FROM t1;
gSQL> SELECT * FROM s1.t1;
```

- It is construed as table s2.t2 by the schema path.

```
gSQL> SELECT * FROM t2;
gSQL> SELECT * FROM s2.t2;
```

- It is construed as table s3.t3 by the schema path.

```
gSQL> SELECT * FROM t3;
gSQL> SELECT * FROM s3.t3;
```

When omitting the schema name to retrieve the table s3.t1 as the example above, the table s3.t1 is determined by schema path, so the schema name should be specified as follows.

- It retrieves the table s1.t1 by the schema path.

```
gSQL> SELECT * FROM t1;
```

- The schema s3 should be specified to retrieve the table s3.t1.



```
gSQL> SELECT * FROM s3.t1;
```

The following CREATE TABLE statement in which the schema name is omitted creates a table in the first schema s1 of the schema path.

- An error occurs because the identical table s1.t1 exists.

```
gSQL> CREATE TABLE t1 ( id INTEGER );
gSQL> CREATE TABLE s1.t1 ( id INTEGER );
```

- The table s2.t2 exists, but the table s1.t2 is created in different schemas.

```
gSQL> CREATE TABLE t2 ( name VARCHAR(128) );
gSQL> CREATE TABLE s1.t2 ( name VARCHAR(128) );
```

- The table s3.t3 exists, but the table s1.t3 is created in different schemas.

```
gSQL> CREATE TABLE t3 ( name VARCHAR(128) );
gSQL> CREATE TABLE s1.t3 ( name VARCHAR(128) );
```

If the current user omits the schema name when creating an object, the schema name to be used can be retrieved by using **CURRENT\_SCHEMA** which is the SQL standard function.

```
gSQL> SELECT current_schema FROM dual;
CURRENT_SCHEMA
-----
S1
1 row selected.
```

The schema path information of the current user can be retrieved by using ALL SCHEMA PATH view in DICTIONARY\_SCHEMA schema.

```
gSQL> SELECT * FROM all_schema_path;
AUTH_NAME  SCHEMA_NAME          SEARCH_ORDER
-----
U1         S1                   1
U1         S2                   2
U1         S3                   3
U1         PUBLIC               4
PUBLIC    DICTIONARY_SCHEMA    5
PUBLIC    INFORMATION_SCHEMA   6
PUBLIC    DEFINITION_SCHEMA    7
```

```
PUBLIC     PERFORMANCE_VIEW_SCHEMA      8
PUBLIC     FIXED_TABLE_SCHEMA         9
9 rows selected.
```

In the example above, the schema path of the user u1 is in an order of {s1, s2, s3, public}, and the schema path of PUBLIC account is in an order of {DICTIONARY\_SCHEMA, INFORMATION\_SCHEMA, DEFINITION\_SCHEMA, PERFORMANCE\_VIEW\_SCHEMA, FIXED\_TABLE\_SCHEMA}.

If omitting the schema name and retrieving a table t1, then it searches for the schema path for the current user u1. If the schema path does not exist in it, then it searches for the schema path of PUBLIC account.

Schema path of a specific user can be altered by using **ALTER USER** statement as follows. The schema path of PUBLIC account can be altered by using ALTER USER PUBLIC SCHEMA PATH statement.

CURRENT PATH clause is used to additionally alter other schemas together with the user's current schema.

- The schema path of user u1 is altered.

```
gSQL> ALTER USER u1 SCHEMA PATH ( s3, s2, s1 );
User altered.
```

- The schema path of PUBLIC account is altered.

```
gSQL> ALTER USER PUBLIC SCHEMA PATH ( s1, s2, s3 );
User altered.
```

- The schema path which includes the current schema path is altered by using CURRENT PATH.

```
gSQL> ALTER USER u1 SCHEMA PATH ( s4, CURRENT PATH );
User altered.
```

The schema path is automatically determined when a user is created by using **CREATE USER** statement. And if the user schema is created by using **CREATE SCHEMA** statement later, then it is not automatically included in the user's schema path, so, if necessary, it should be included in the schema path by using **ALTER USER** statement. For more information, refer to each statement.

## PUBLIC Schema

PUBLIC schema is a shared schema in which any user can create objects. As shown in the example below, if the user who does not have the schema creates the table whose schema name is not specified, then the table's schema is PUBLIC.

- A user u1 who does not have the schema is created.

```
gSQL> CREATE USER u1 IDENTIFIED BY u1_password WITHOUT SCHEMA;
gSQL> GRANT CREATE SESSION TO u1;
gSQL> GRANT CREATE OBJECT ON TABLESPACE mem_data_tbs TO u1;
```

- The user u1 creates a table.

```
% gsql u1 u1_password
gSQL> CREATE TABLE t1 ( id INTEGER );
```

- The statements above have the same meaning as the following.

```
gSQL> CREATE TABLE public.t1 ( id INTEGER );
```

In the example above, the table t1's schema which is created by user u1, is PUBLIC. PUBLIC schema is a built-in schema which is automatically created when creating the database.

It is granted the privilege of the same meaning as the following statement so that any user can create an object in the schema.

```
gSQL> GRANT CREATE TABLE, CREATE VIEW, CREATE INDEX, CREATE SEQUENCE, ADD CONSTRAINT
      ON SCHEMA PUBLIC
      TO PUBLIC;
```

PUBLIC schema, shared schema, is different from PUBLIC account which means all users. In the statement above, the privilege of creating objects in the PUBLIC schema (ON SCHEMA PUBLIC) is granted to PUBLIC account (TO PUBLIC) which means all users.

Any user can create or manage tables, but an appropriate privilege is required for retrieving the table created in PUBLIC schema by another user.

The followings are examples of GRANT statements using PUBLIC account and PUBLIC schema.

- SELECT privilege on table u1.t1 is granted to PUBLIC account.
- Any user can retrieve the table u1.t1.

```
gSQL> GRANT SELECT ON TABLE u1.t1 TO PUBLIC;
```

- SELECT privilege on all tables in PUBLIC schema is granted to user u1.
- The user u1 can retrieve all tables in PUBLIC schema.

```
gSQL> GRANT SELECT TABLE ON SCHEMA PUBLIC TO u1;
```

## Examples of Using User and Schema

For example, if a single administrator and multiple developers use a single schema, the schema can be controlled by using the following SQL statement.

The following examples describe how to create a `mgr_usr` user who manages our\_schema schema, and a number of users such as `app_user1`, `app_user2`, `app_user3` who develops applications using our\_schema.

A `mgr_user` user and a `our_schema` schema are created as follows.

- `mgr_user` and `our_schema` are created.
- `mgr_user` owns `our_schema`.

```
gSQL> CREATE USER mgr_user IDENTIFIED BY mgr_user WITH SCHEMA our_schema;  
User created.
```

- An appropriate privilege is granted to `mgr_user`.

```
gSQL> GRANT ALL PRIVILEGES ON DATABASE TO mgr_user;  
Grant succeeded.  
gSQL> COMMIT;  
Commit complete.
```

Multiple `app_user` users are created as follows.

The `app_user` users are allowed to execute only `SELECT` and `DML` statements on `our_schema`.

- Multiple `app_user` users who do not own the schema are created as follows.

```
gSQL> CREATE USER app_user1 IDENTIFIED BY app_user1 WITHOUT SCHEMA;  
User created.  
gSQL> CREATE USER app_user2 IDENTIFIED BY app_user2 WITHOUT SCHEMA;  
User created.  
gSQL> CREATE USER app_user3 IDENTIFIED BY app_user3 WITHOUT SCHEMA;  
User created.  
gSQL> COMMIT;  
Commit complete.
```

- The access privileges are granted to multiple `app_user` users.

```
gSQL> GRANT CREATE SESSION ON DATABASE TO app_user1, app_user2, app_user3;  
Grant succeeded.  
gSQL> COMMIT;
```

Commit complete.

- Only read/write privileges on our\_schema are granted to multiple app\_user users.

```
gSQL> GRANT SELECT TABLE, INSERT TABLE, UPDATE TABLE, DELETE TABLE ON SCHEMA our_schema TO
app_user1, app_user2, app_user3;
Grant succeeded.
gSQL> COMMIT;
Commit complete.
```

- SCHEMA\_PATH of multiple app\_user users is specified as our\_schema.

```
gSQL> ALTER USER app_user1 SCHEMA PATH ( our_schema );
User altered.
gSQL> ALTER USER app_user2 SCHEMA PATH ( our_schema );
User altered.
gSQL> ALTER USER app_user3 SCHEMA PATH ( our_schema );
User altered.
gSQL> COMMIT;
Commit complete.
```

Through the operations above, mgr\_user has DDL privileges of creating/ dropping/ altering an object in our\_schema, but multiple app\_user can only read/write operations on the tables in our\_schema.

mgr\_user can perform management tasks such as creating a table as follows.

```
gSQL> \connect mgr_user mgr_user
gSQL> CREATE TABLE t1 ( c1 INTEGER );
Table created.
gSQL> INSERT INTO t1 VALUES ( 1 );
1 row created.
gSQL> INSERT INTO t1 VALUES ( 2), ( 3);
2 rows created.
gSQL> COMMIT;
Commit complete.
```

Multiple app\_user can read/write operation for the table in our\_schema without specifying the schema name, but they are not allowed to create or drop an object as follows.

```
gSQL> \connect app_user1 app_user1
gSQL> SELECT * FROM t1;
C1
--
```

1

2

3

3 rows selected.

```
gSQL> INSERT INTO t1 VALUES (4);
```

1 row created.

```
gSQL> COMMIT;
```

Commit complete.

```
gSQL> DROP TABLE t1;
```

```
ERR-42000(16208): insufficient privileges
```

## 13.6 Tablespace

### Tablespace-related Statements

For more information, refer to the followings.

- Creating tablespace
  - CREATE TABLESPACE
  - CREATE MEMORY DATA TABLESPACE
  - CREATE MEMORY TEMPORARY TABLESPACE
  - CREATE DISK DATA TABLESPACE
- Dropping tablespace: DROP TABLESPACE
- Altering tablespace
  - ALTER TABLESPACE
  - ALTER TABLESPACE name RENAME TO
  - ALTER TABLESPACE name BACKUP
  - ALTER TABLESPACE name [ONLINE|OFFLINE]
- Adding, dropping, altering the datafile which configures the tablespace
  - ALTER TABLESPACE name ADD [DATAFILE|MEMORY]
  - ALTER TABLESPACE name DROP [DATAFILE|MEMORY]
  - ALTER TABLESPACE name RENAME DATAFILE
  - ALTER DATABASE DATAFILE AUTOEXTEND

Information which is related to a tablespace object can be retrieved through the following views.

**Table 13-13** Tablespace object related information

| Schema            | View             | Description                                |
|-------------------|------------------|--------------------------------------------|
| DICTIONARY_SCHEMA | USER_TABLESPACES | Information of user accessible tablespaces |

### Concepts of Tablespace

A tablespace is a logical concept and it consists of one or more physical shared memory. It is a space to store data, such as tables, indexes.

Physical objects such as tables, indexes which are stored in a tablespace can be spanned multiple shared memories as shown below.

A tablespace can be extended by adding the shared memory.

**Figure 6** Concept of tablespace

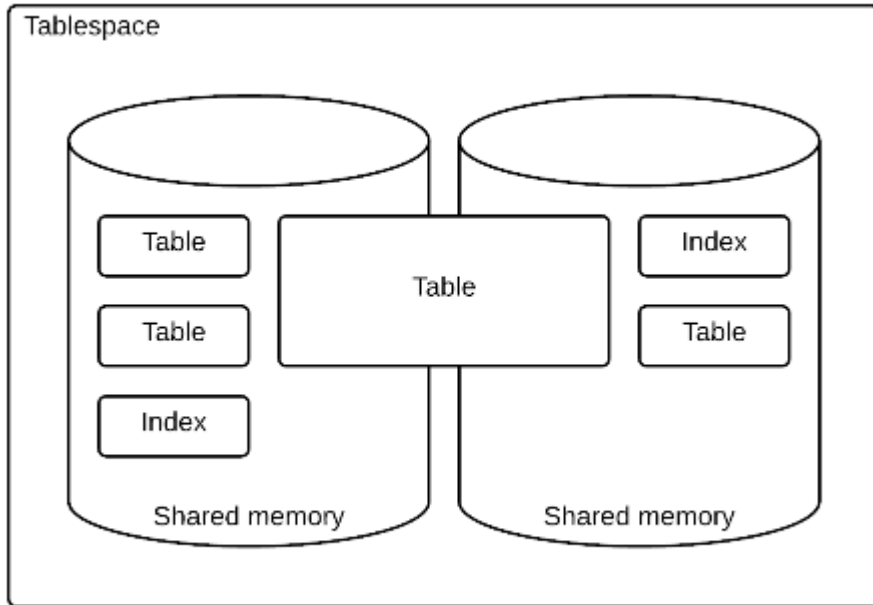

Tablespaces are classified into three types depending on the stored data type as follows.

- DATA TABLESPACE
  - It is tablespace to store and manage permanent data such as tables, logging indexes.
- TEMPORARY TABLESPACE
  - It is tablespace to store and manage volatile data such as the indexes without logging, the hash which is generated during query execution and the sort.
- UNDO TABLESPACE
  - It is tablespace to store and manage the data change information for rollback the transaction.

Tables, indexes (LOGGING) stored in DATA tablespace create redo logs to permanently manage data. However, indexes without logging stored in TEMPORARY tablespace do not create redo logs. The index without logging does not log the changes. When restarting the system, it is rebuilt based on the table data, and the index facility is retained.

A tablespace is a physical storage in which SQL schema objects are stored. A particular tablespace can be specified when creating a table and index. A table, the index which is related to the table, and the indexes which is created for the constraint condition of the table can be stored in different tablespaces.

For more information about specifying the tablespace when creating an object, refer to the followings.

- CREATE TABLE
- CREATE INDEX



- ALTER TABLE name ADD CONSTRAINT

If a tablespace is not specified when creating an object such as a table or index, the default tablespace is used.

For more information about the user's default tablespace, refer to the followings.

- CREATE USER
- ALTER USER

For more information about tablespace, refer to **Managing Tablespace**.

## 13.7 Table

### Table-related Statements

Statements for creating, dropping, altering a table are as follows.

- Creating table
  - **CREATE TABLE**
  - **CREATE TABLE AS SELECT**
  - **CREATE GLOBAL TEMPORARY TABLE**
  - **CREATE IMMUTABLE TABLE**
- Dropping table
  - **DROP TABLE**
  - **TRUNCATE TABLE**
- Altering table
  - **ALTER TABLE**
  - **ALTER TABLE name RENAME TO**
  - **ALTER TABLE name STORAGE**
- Adding, dropping, altering a column of the table
  - **ALTER TABLE name ADD COLUMN**
  - **ALTER TABLE name SET UNUSED COLUMN**
  - **ALTER TABLE name ALTER COLUMN**
  - **ALTER TABLE name RENAME COLUMN**
- Adding, dropping, altering a constraint of the table
  - **ALTER TABLE name ADD CONSTRAINT**
  - **ALTER TABLE name DROP CONSTRAINT**
  - **ALTER TABLE name ALTER CONSTRAINT**
- Adding, dropping additional log of the table
  - **ALTER TABLE name ADD SUPPLEMENTAL LOG**
  - **ALTER TABLE name DROP SUPPLEMENTAL LOG**
- Table statistics information: **ANALYZE TABLE**.
- Managing recycle bin of the table
  - **FLASHBACK TABLE**

- PURGE

Information which is related to a table object can be retrieved through the following views.

**Table 13-14** Table object related information

| Schema                 | View                                                | Description                                              |
|------------------------|-----------------------------------------------------|----------------------------------------------------------|
| DICTIONARY_SCHEMA      | ALL_ALL_TABLES                                      | Information about user accessible tables                 |
|                        | ALL_COL_COMMENTS                                    | Information about comments of user accessible column     |
|                        | ALL_CONSTRAINTS                                     | Information about user accessible constraints            |
|                        | ALL_CONS_COLUMNS                                    | Column information about user accessible constraints     |
|                        | ALL_TABLES                                          | Information about user accessible tables                 |
|                        | ALL_TAB_COLS                                        | Information about user accessible columns                |
|                        | ALL_TAB_COLUMNS                                     | Information about user accessible columns                |
|                        | ALL_TAB_COMMENTS                                    | Information about comments of user accessible tables     |
|                        | ALL_TAB_IDENTITY_COLS                               | Identity column information about user accessible tables |
|                        | USER_ALL_TABLES                                     | Information about user owned tables                      |
|                        | USER_COL_COMMENTS                                   | Information about comments of user owned columns         |
|                        | USER_CONSTRAINTS                                    | Information about user owned constraints                 |
|                        | USER_CONS_COLUMNS                                   | Column information about user owned constraints          |
|                        | USER_RECYCLEBIN                                     | Information about user owned recycle bin object          |
|                        | USER_TABLES                                         | Information about user owned tables                      |
|                        | USER_TAB_COLS                                       | Information about user owned columns                     |
|                        | USER_TAB_COLUMNS                                    | Information about user owned columns                     |
|                        | USER_TAB_COMMENTS                                   | Information about comments of user owned tables          |
| USER_TAB_IDENTITY_COLS | Identity column information about user owned tables |                                                          |
| INFORMATION_SCHEMA     | COLUMNS                                             | Information about user accessible columns                |
|                        | CONSTRAINT_COLUMN_USAGE                             | Column information about user accessible constraints     |
|                        | CONSTRAINT_TABLE_USAGE                              | Table information about user accessible constraints      |
|                        | KEY_COLUMN_USAGE                                    | Column information about user accessible key constraints |
|                        | TABLES                                              | Information about user accessible tables                 |
|                        | TABLE_CONSTRAINTS                                   | Information about user accessible constraints            |

## Concepts of Table

Table is an underlying object which configures the database. In the SQL standard, the table is called as a base table, and the view is called as a viewed table.

The table consists of columns and rows. The table consists of multiple rows, the number and order of columns in each row is same.

The table consists of one or more columns, and each column has a name but a row does not have a name. The order of the row is not always as same as the order in which data is added.

The value is the data in intersection of a column and a row. Column is the set of value which have the same data type.

Each column of a table has a unique name to be distinguished from other columns in the table. It has a data type which corresponds to the characteristics of the value. For more information about data type, refer to **Data Type** section.

The constraints can be added to the table for data integrity. For more information about constraint, refer to **CREATE TABLE, ALTER TABLE name ADD CONSTRAINT**.

The table index can be created to improve performance of queries. For more information about index, refer to **Index** section.

The following is an example of creating a lineitem table using **CREATE TABLE** statement.

```
CREATE TABLE lineitem
(
  l_orderkey      INTEGER    NOT NULL
, l_partkey      INTEGER    NOT NULL
, l_suppkey      INTEGER    NOT NULL
, l_linenumber   INTEGER    NOT NULL
, l_quantity     NUMERIC(12,2)
, l_extendedprice NUMERIC(12,2)
, l_discount     NUMERIC(12,2)
, l_tax          NUMERIC(12,2)
, l_returnflag   CHAR(1)    NOT NULL  DEFAULT 'F'
, l_linestatus   CHAR(1)
, l_shipdate     DATE
, l_commitdate   DATE
, l_receiptdate  DATE
, PRIMARY KEY (l_orderkey, l_linenumber) INDEX lineitem_pk_idx TABLESPACE mem_temp_tbs
) TABLESPACE mem_data_tbs;
```

In the example above, multiple columns and constraints are defined in the lineitem table. When using constraints to define columns, NOT NULL constraints are defined for the columns l\_orderkey, l\_partkey, l\_suppkey, l\_linenumber.

PRIMARY KEY constraint is defined by combining columns of l\_orderkey, l\_linenumber.

In-line constraint is described together with the column definitions. Out-line constraint is described separately from the column definitions.

Using DEFAULT clause in the column l\_returnflag, the value 'F' is declared as a default value for the column. The index which is created when creating PRIMARY KEY constraints is named separately as lineitem\_pk\_idx. The tablespace in which the index will be stored is named as mem\_temp\_tbs. The table is physically stored in the tablespace mem\_data\_tbs.

The following is an example of adding a constraint to a table using **ALTER TABLE name ADD CONSTRAINT** statement.

```
ALTER TABLE lineitem
  ADD CONSTRAINT lineitem_unique_all_key
  UNIQUE( l_orderkey ASC, l_partkey DESC, l_suppkey DESC, l_linenum ASC);
```

In the example above, UNIQUE constraint is added to the lineitem table, and the column sort order ASC/DESC is specified for the automatically created index of constraints.

The following is an example of adding columns to the table using **ALTER TABLE name ADD COLUMN** statement.

```
ALTER TABLE lineitem ADD COLUMN
(
  l_shipinstruct CHAR(25)
, l_shipmode     CHAR(10)
, l_comment      VARCHAR(44)
);
```

In the example above, multiple columns are added to a table. The in-line constraints or default values can be specified when adding columns.

The following is an example of creating an index in the table using **CREATE INDEX** statement.

```
CREATE INDEX lineitem_idx_shipdate ON lineitem( l_shipdate ASC NULLS LAST );
```

The example above describes the index which is created for the column l\_shipdate which is often used as the query conditions. The column sort order is ascending (ASC), and if NULL value exists, it is specified to be located at the end.

For more information about DML statements of inserting/deleting/updating data to a table, refer to **Data Manipulation Language** clause.

For more information about SELECT statements of querying data in a table, refer to **Data Query Language** clause, **SELECT** statement.

## Global Temporary Table

Global temporary table is a kind of temporary table and the table definition is shared by all users, but the data is separated per session.

The table definition is created when executing `CREATE GLOBAL TEMPORARY TABLE`, but the physical segment is created in a state which is dependent on a session when executing `INSERT` to that table for the first time. The segments which are allocated to all global temporary tables created in the session are released when the session is terminated. An option defined at the time of creating a global temporary table determines whether to truncate the data left after committing or rolling back.

It supports all DDL and DML provided by a table except for cluster-related statements. A DDL statement returns an error to the global temporary table which is used by the current session. However, `TRUNCATE TABLE` statement for a global temporary table is applied only to the current session, so it does not return an error even when it is used by another session.

A global temporary table can be defined only in a temporary tablespace, so it does not record a redo log or restart recovery. However, it records the undo log for MVCC and rollback, and the space on which the undo log is recorded can be selected to system undo tablespace or system temp tablespace by using `TEMP_UNDO_ENABLED`.

If `TEMP_UNDO_ENABLED` is 1, it records undo logs in a temp undo relation of the session separately from the undo relation of the transaction. If the transaction performs only DML for a global temporary table, then it does not record the transaction record nor the commit log, so it improves the DML performance.

When releasing the segment used in the session, it is returned to the corresponding tablespace, and it is allocated again from the tablespace when allocating again. The process allocating and returning segments in a tablespace costs a lot to keep concurrency with other sessions and to allocate and release segments. Therefore, the segment which was released after used in a session can be reused without returning it by using `TEMP_SEGMENT_CACHE_SIZE`.

In other words, if `TEMP_SEGMENT_CACHE_SIZE` is set to 0 (default value), then it immediately returns the segment which is released after used to the tablespace. If `TEMP_SEGMENT_CACHE_SIZE` is set to the value bigger than 1 (maximum 4294967295), then it reuses as many segments as set in a session when returning the segment.

When a global temporary table is not used in a session any more, then cleanup segments in a segment cache at once by using `ALTER SESSION CLEANUP GLOBAL TEMPORARY SEGMENT POOL`.

The following is an example of creating a global temporary table by using `CREATE GLOBAL TEMPORARY TABLE`.

```
CREATE GLOBAL TEMPORARY TABLE SESSION_TABLE1(
    COL1 CHAR(10)
    ,COL2 VARCHAR2(20)
    ,COL3 NUMBER(10)
) ON COMMIT DELETE ROWS;
```

The information about the created global temporary table can be viewed in `DICTIONARY` tables or views in the same way as viewing the information of an ordinary table.

## Table in Cluster

For more information about a table in the cluster environment, refer to [Cluster Table and Shard](#).

## Managing Recycle Bin of Table

### Syntax

- Restoring an object stored in the recycle bin.
  - `FLASHBACK TABLE`
- Dropping an object stored in the recycle bin.
  - `PURGE`

The information about the recycle bin can be retrieved through the following views.

**Table 13-15** Information about the recycle bin

| Schema            | View                         | Description                                                |
|-------------------|------------------------------|------------------------------------------------------------|
| DICTIONARY_SCHEMA | <code>DBA_RECYCLEBIN</code>  | Information about all recycle bins in the database         |
|                   | <code>USER_RECYCLEBIN</code> | Information about the recycle bin which is owned by itself |
|                   | <code>RECYCLEBIN</code>      | Alias of <code>USER_RECYCLEBIN</code>                      |

### Description

It stores the dropped object in the recycle bin instead of completely dropping it. Constraints and indexes related to the table are also stored in the recycle bin.

The concept of the recycle bin is also called as *flashback drop* feature, and objects stored in the recycle bin can be dropped or be restored by using `PURGE` or `FLASHBACK TABLE` statement.

If a table is dropped and stored in the recycle bin, then all names of objects related to the table are altered and stored. The altered name is in a form of BIN\$unique\_name, and the database creates and gives the unique values. unique\_name is created in a value of 32 characters.

When restoring tables stored in the recycle bin, constraints and indexes related to the table are restored in its original of when before they were dropped. However, if a name of when before the object was dropped already exists, then the object is restored in the name of when it is stored in the recycle bin.

**RECYCLEBIN** property should be activated to use the recycle bin feature. The property can be altered with ALTER SESSION and ALTER SYSTEM, and ALTER SYSTEM has DEFERRED property. The default value is FALSE.

```
gSQL> ALTER SESSION SET RECYCLEBIN = ON;
Session altered.
gSQL> ALTER SYSTEM SET RECYCLEBIN = ON DEFERRED;
System altered.
```

## Feature

- The object stored in the recycle bin is not physically dropped. Therefore the tablespace used by the corresponding object is not released.
- Each user has its own recycle bin and a user can view its own recycle bin.
- If there are multiple tables with the same name, then the oldest object is dropped when dropping an object stored in the recycle bin.
- If there are multiple tables with the same name, then the newest object is restored when restoring an object stored in the recycle bin.
- DICTIONARY VIEW can retrieve objects stored in the recycle bin, but INFORMATION VIEW can not retrieve objects stored in the recycle bin.
- PURGE DBA\_RECYCLEBIN ON DATABASE privilege is required to drop all recycle bins in the database.
- PURGE and FLASHBACK TABLE statements can be audited with AUDIT SYSTEM ACTION.
- If a tablespace is dropped, then the recycle bins included in the tablespace are also dropped.
- If a schema is dropped, then the recycle bins included in the schema are also dropped.
- If a user is dropped, then the user's recycle bin is also dropped.



Only some DML and DDL are allowed for the object stored in the recycle bin, and statements except for the statements below cause an error.

- SELECT
- SELECT .. FOR UPDATE
- LOCK TABLE
- COMMENT ON TABLE name IS
- COMMENT ON COLUMN name IS



- COMMENT ON INDEX name IS
- COMMENT ON CONSTRAINT name IS
- GRANT privileges TO
- REVOKE privileges FROM
- CREATE TABLE AS SELECT
- CREATE GLOBAL TEMPORARY TABLE AS SELECT
- CREATE AUDIT POLICY
- ALTER AUDIT POLICY
- CREATE VIEW
- CREATE SYNONYM
- CREATE FUNCTION
- CREATE PROCEDURE
- ALTER FUNCTION
- ALTER PROCEDURE
- ALTER DATABASE MOVE SHARD
- ALTER DATABASE REBALANCE
- ALTER DATABASE REBALANCE EXCLUDE CLUSTER GROUP
- ALTER TABLE name REBALANCE
- ALTER TABLE name REBALANCE EXCLUDE CLUSTER GROUP
- ALTER TABLE name MOVE SHARD
- ALTER TABLE name SPLIT SHARD
- ALTER TABLE name MERGE SHARD
- ALTER TABLE name SYNCHRONIZE IDENTITY COLUMN

## Example

RECYCLEBIN property should be activated to use the recycle bin feature.

```
gSQL> ALTER SESSION SET RECYCLEBIN = ON;
Session altered.
gSQL> CREATE TABLE t1 ( id INTEGER PRIMARY KEY, name VARCHAR(32) );
Table created.
gSQL> DROP TABLE t1;
Table dropped.
gSQL> CREATE TABLE t1 ( id INTEGER PRIMARY KEY, name VARCHAR(32) );
Table created.
gSQL> DROP TABLE t1;
Table dropped.
gSQL> COMMIT;
Commit complete.
```

```
gSQL> SELECT OBJECT_NAME, ORIGINAL_NAME, OBJECT_TYPE, DROPPED_TIME FROM USER_RECYCLEBIN;
```

| OBJECT_NAME                                                                   | ORIGINAL_NAME | OBJECT_TYPE | DROPPED_TIME |
|-------------------------------------------------------------------------------|---------------|-------------|--------------|
| BIN\$8981D28E172C11EAA7C5D51B86D72AB6 T1<br>15:57:44.120000                   |               | TABLE       | 2019-12-05   |
| BIN\$8981D2C0172C11EAA7C5D51B86D72AB6 T1_PRIMARY_KEY<br>15:57:44.120000       |               | CONSTRAINT  | 2019-12-05   |
| BIN\$8981D2AC172C11EAA7C5D51B86D72AB6 T1_PRIMARY_KEY_INDEX<br>15:57:44.120000 |               | INDEX       | 2019-12-05   |
| BIN\$8F1E9614172C11EAA7C5D51B86D72AB6 T1<br>15:57:53.540000                   |               | TABLE       | 2019-12-05   |
| BIN\$8F1E9650172C11EAA7C5D51B86D72AB6 T1_PRIMARY_KEY<br>15:57:53.540000       |               | CONSTRAINT  | 2019-12-05   |
| BIN\$8F1E963C172C11EAA7C5D51B86D72AB6 T1_PRIMARY_KEY_INDEX<br>15:57:53.540000 |               | INDEX       | 2019-12-05   |

6 rows selected.

```
gSQL> PURGE TABLE t1;
```

Table purged.

```
gSQL> SELECT OBJECT_NAME, ORIGINAL_NAME, OBJECT_TYPE, DROPPED_TIME FROM USER_RECYCLEBIN;
```

| OBJECT_NAME                                                                   | ORIGINAL_NAME | OBJECT_TYPE | DROPPED_TIME |
|-------------------------------------------------------------------------------|---------------|-------------|--------------|
| BIN\$8F1E9614172C11EAA7C5D51B86D72AB6 T1<br>15:57:53.540000                   |               | TABLE       | 2019-12-05   |
| BIN\$8F1E9650172C11EAA7C5D51B86D72AB6 T1_PRIMARY_KEY<br>15:57:53.540000       |               | CONSTRAINT  | 2019-12-05   |
| BIN\$8F1E963C172C11EAA7C5D51B86D72AB6 T1_PRIMARY_KEY_INDEX<br>15:57:53.540000 |               | INDEX       | 2019-12-05   |

3 rows selected.

```
gSQL> FLASHBACK TABLE t1 TO BEFORE DROP;
```

Flashback complete.

```
gSQL> DESC T1
```

| COLUMN_NAME          | TYPE            | IS_NULLABLE      |           |         |  |
|----------------------|-----------------|------------------|-----------|---------|--|
| ID                   | NUMBER(10,0)    | FALSE            |           |         |  |
| NAME                 | VARCHAR(32)     | TRUE             |           |         |  |
| INDEX_NAME           | TABLESPACE_NAME | INDEX_TYPE       | IS_UNIQUE | COLUMNS |  |
| T1_PRIMARY_KEY_INDEX | MEM_TEMP_TBS    | BTREE            | TRUE      | ID      |  |
| CONSTRAINT_NAME      | CONSTRAINT_TYPE | ASSOCIATED_INDEX | COLUMNS   |         |  |

```
-----  
T1_PRIMARY_KEY PRIMARY KEY T1_PRIMARY_KEY_INDEX ID
```

```
gSQL> SELECT OBJECT_NAME, ORIGINAL_NAME, OBJECT_TYPE, DROPPED_TIME FROM USER_RECYCLEBIN;
```

```
no rows selected.
```

## 13.8 Index

### Index-related Statements

Statements for creating, dropping, altering an index are as follows.

- Creating an index: Refer to **CREATE INDEX**.
- Dropping an index: Refer to **DROP INDEX**.
- Updating an index: Refer to **ALTER INDEX**.

Information which is related to an index object can be retrieved through the following views.

**Table 13-16** Index object related information

| Schema            | View             | Description                                    |
|-------------------|------------------|------------------------------------------------|
| DICTIONARY_SCHEMA | ALL_INDEXES      | Information about user accessible indexes      |
|                   | ALL_IND_COLUMNS  | Column information about user accessible index |
|                   | USER_INDEXES     | Information about user owned indexes           |
|                   | USER_IND_COLUMNS | Column information about user owned index      |

### Concepts of Index

Index is a table related object, and it is used to improve data access performance when retrieving the table. Each index consists of key values using the data in one or more columns of the table. It is an object which is separate from a table.

Database automatically builds the key data of the index when creating the index, and the index key data is automatically managed when adding/deleting/ updating the table data.

The following is an example of a query.

```
SELECT data FROM t1 WHERE id = 12345;
```

If an index does not exist, the results which satisfy the condition are found by checking all rows in the table. If the table consists of multiple rows while the number of results to satisfy the condition is relatively small, the query above has a very inefficient response time.

When creating an index in id column by using the **CREATE INDEX** statement as follows, the optimizer evaluates the costs between the full scan and index scan of a table, and selects the index scan to improve query performance.

```
CREATE INDEX t1_idx_id ON t1(id);
```

When creating an index, two or more columns can be used as an index key, and the index which consists of two or more keys is called as a composite index. The composite index is sorted by the first key, or sorted by the second key if the first key value is same. It is sorted as many as the number of the keys in this way.

When creating indexes, the column sort order can be specified in ascending (ASC) or descending (DESC). The sort order of NULL value can be specified as NULLS FIRST or NULLS LAST. Refer to the following example.

```
gSQL> CREATE TABLE t1 ( value INTEGER );
Table created.
gSQL> INSERT INTO t1 VALUES (1), (NULL), (3), (2), (NULL);
5 rows created.
gSQL> CREATE INDEX idx1 ON t1 ( value ASC NULLS LAST );
Index created.
gSQL> CREATE INDEX idx2 ON t1 ( value DESC NULLS FIRST );
Index created.
gSQL> SELECT /*+ INDEX(t1, idx1) */ * FROM t1;
VALUE
-----
    1
    2
    3
  null
  null
5 rows selected.
gSQL> SELECT /*+ INDEX(t1, idx2) */ * FROM t1;
VALUE
-----
  null
  null
    3
    2
    1
5 rows selected.
```

In the example above, the index idx1 is specified in the ascending order (ASC), which is NULLS LAST, and the index idx2 is specified in the descending order (DESC), which is NULLS FIRST.

It uses the different index hints when retrieving the table with the same query, so all rows are retrieved by using each index. Results using the index idx1 is sorted in ascending order, and NULL value is located at t

he end. However, the results using the index idx2 is sorted in descending order and NULL value is located in the first.

## Concepts of UNIQUE

Index can be created as UNIQUE index or non-unique index. If the key values is not UNIQUE when creating UNIQUE index, then an error occurs.

NULL value is allowed as a key value in UNIQUE index and UNIQUE constraint.

If NULL value is included, the truth table for UNIQUE is as follows. In other words, if the key is one, then it can have multiple null values.

**Table 13-17** Truth table for UNIQUE in two values

| Value1 | Value2 | UNIQUE |
|--------|--------|--------|
| 1      | 1      | false  |
| 1      | 2      | true   |
| 1      | null   | true   |
| null   | null   | true   |

The UNIQUE index or UNIQUE constraint consisting of two or more keys can have null as the whole value or partial value. If NULL is included in the composite key, the truth table for UNIQUE is as follows.

**Table 13-18** Truth table for UNIQUE in composite key

| Row1         | Row2         | UNIQUE |
|--------------|--------------|--------|
| (1, 1)       | (1, 1)       | false  |
| (1, 1)       | (1, 2)       | true   |
| (1, null)    | (1, null)    | false  |
| (1, null)    | (2, null)    | true   |
| (null, null) | (null, null) | true   |

Note that the definition of the UNIQUE has been changed in the SQL standard as follows.



- UNIQUE definition until SQL1999

If there are no two rows in T such that the value of each column in one row is non-null and **is equal to** the value of the corresponding column in the other row according to Subclause 8.2, “<comparison predicate>”, then the result of the <unique predicate> is true; otherwise, the result of the <unique predicate> is false.

- UNIQUE definition after SQL2003

If there are no two rows in T such that the value of each column in one row is non-null and **is not distinct from** the value of the corresponding column in the other row, then the result of the <unique predicate> is True; otherwise, the result of the <unique predicate> is False.

GOLDILOCKS follows the SQL2011 standard which is the standard after SQL2003, and the SQL standard UNIQUE is defined by whether or not UNIQUE of composite key exists as shown in the following table.

**Table 13-19** Truth table for UNIQUE of the SQL standard composite key

| Row1         | Row2         | Until SQL1999 | After SQL2003 |
|--------------|--------------|---------------|---------------|
| (1, 1)       | (1, 1)       | false         | false         |
| (1, 1)       | (1, 2)       | true          | true          |
| (1, null)    | (1, null)    | true          | false         |
| (1, null)    | (2, null)    | true          | true          |
| (null, null) | (null, null) | true          | true          |

Each DBMS vendor follows the SQL standard for UNIQUE definition as follows.

- DBMS which follows the UNIQUE definition after SQL2003: Oracle, SQL server
- DBMS which follows the UNIQUE definition until SQL1999: Postgres, MySQL

## 13.9 View

### View-related Statements

Statements for creating, dropping, altering a view are as follows.

- Creating a view: Refer to **CREATE VIEW**.
- Dropping a view: Refer to **DROP VIEW**.
- Altering a view: Refer to **ALTER VIEW**.

Information which is related to a view object can be retrieved through the following views.

**Table 13-20** View object related information

| Schema             | View               | Description                                                     |
|--------------------|--------------------|-----------------------------------------------------------------|
| DICTIONARY_SCHEMA  | ALL_VIEWS          | Information about user accessible views                         |
|                    | ALL_DEPENDENCIES   | Information about objects related to user accessible views      |
|                    | USER_VIEWS         | Information about user owned views                              |
|                    | USER_DEPENDENCIES  | Information about objects related to user owned views           |
| INFORMATION_SCHEMA | VIEWS              | Information about user accessible views                         |
|                    | VIEW_TABLE_USAGE   | Information about the table used when creating a view           |
|                    | VIEW_ROUTINE_USAGE | Information about the stored function used when creating a view |

### Concepts of View

While a table is a physical relation of storing data, a view is a logical relation consisting of queries. In the SQL standard, it is called as the viewed table. Queries about view can be used as same as the table.

A view has the following advantages.

- Data access can be restricted to allow querying only part of the information in the table.
- The complex and frequent queries can be written in a single view to decrease query's complexity.
- Data can be presented in a perspective different from the table perspective by changing the column names or data of the view.
- Creating applications of views is not affected by the changes in table structures.

The view which is created by a **CREATE VIEW** statement is replaced with in-line view when executing queries as follows.



- Creating a view

```
CREATE VIEW v1 ( v_id, v_sum )
AS
SELECT l_partkey, SUM( l_quantity )
   FROM lineitem
  GROUP BY l_partkey;
```

- Querying the view

```
SELECT v_id, v_sum
   FROM v1
  WHERE v_sum > 1000;
```

- Translating the view

```
SELECT v_id, v_sum
   FROM ( SELECT l_partkey, SUM( l_quantity )
          FROM lineitem
        GROUP BY l_partkey
        ) v1 ( v_id, v_sum )
  WHERE v_sum > 1000;
```

In the following example, the asterisk (\*) is used in SELECT statement when creating a view v1, and the asterisk means all columns.

In this case, as follows, all the columns including the added column can be retrieved by executing query of view v1 even after a new column addr is added to the table t1 of which the view is approaching.

```
gSQL> CREATE TABLE t1 ( id INTEGER, name VARCHAR(128) );
Table created.
gSQL> INSERT INTO t1 VALUES ( 1, 'leekmo' );
1 row created.
```

- Creating a view by using an asterisk (\*)

```
gSQL> CREATE VIEW v1 AS SELECT * FROM t1;
View created.
```

- Querying the view

```
gSQL> SELECT * FROM v1;
ID NAME
```

```
-- -----  
1 leekmo  
1 row selected.
```

- Adding a column to the table which is referenced by the view

```
gSQL> ALTER TABLE t1 ADD COLUMN addr VARCHAR(1024) DEFAULT 'N/A';  
Table altered.
```

- Querying the view after adding the column

```
gSQL> SELECT * FROM v1;  
ID NAME  ADDR  
-- -----  
1 leekmo N/A  
1 row selected.
```

However, creating a view using the asterisk (\*) is not recommended because it can cause changes in the application when changing the table structure.

## 13.10 Sequence

### Sequence-related Statements

Statements for creating, dropping, altering, using a sequence are as follows.

- Creating a sequence: Refer to **CREATE SEQUENCE**.
- Dropping a sequence: Refer to **DROP SEQUENCE**.
- Altering a sequence: Refer to **ALTER SEQUENCE**.
- Using a sequence: Refer to **NEXTVAL**, **CURRVAL**.

Information which is related to a sequence object can be retrieved through the following views.

**Table 13-21** Sequence object related information

| Schema             | View           | Description                                 |
|--------------------|----------------|---------------------------------------------|
| DICTIONARY_SCHEMA  | ALL_SEQUENCES  | Information about user accessible sequences |
|                    | USER_SEQUENCES | Information about user owned sequences      |
| INFORMATION_SCHEMA | SEQUENCES      | Information about user accessible sequences |

### Concepts of Sequence

Sequence is an object which automatically creates a sequential number, and it is called as sequence generator in the SQL standard. Sequence is a useful object to automatically manage the unique key or primary key. A sequence can be spanned multiple tables.

The following is an example of using a single sequence object to automatically generate the id column value, and using it across multiple tables.

```
gSQL> CREATE SEQUENCE seq;
Sequence created.
gSQL> INSERT INTO t1 (id, name) VALUES ( seq.NEXTVAL, 'leekmo' );
1 row created.
gSQL> INSERT INTO t2 (id, addr) VALUES ( seq.CURRVAL, 'Seoul, Korea' );
1 row created.
gSQL> SELECT * FROM t1;
ID NAME
-- -----
1 leekmo
1 row selected.
```

```

gSQL> SELECT * FROM t2;
ID ADDR
-- -----
1 Seoul, Korea
1 row selected.

```

In the example above, the next number of the id column in table t1 is automatically created by using the seq.NEXTVAL function. The same value is used for id column in table t2 by using the seq.CURRVAL function.

When creating the sequence, the starting value, incremental value, minimum value, maximum value, cycle or no cycle and cached value of the automatically generated number can be specified.

For more information, refer to **CREATE SEQUENCE** statement.

An identity column is similar to a sequence, and it automatically generates numbers in a table. It can be used as follows.

```

gSQL> CREATE TABLE t1 ( id INTEGER GENERATED ALWAYS AS IDENTITY, name VARCHAR(128) );
Table created.
gSQL> INSERT INTO t1 (name) VALUES ( 'leekmo' );
1 row created.
gSQL> INSERT INTO t1 (name) VALUES ( 'mkkim' );
1 row created.
gSQL> INSERT INTO t1 (name) VALUES ( 'xcom73' );
1 row created.
gSQL> SELECT * FROM t1;
ID NAME
-- -----
1 leekmo
2 mkkim
3 xcom73
3 rows selected.

```

In the example above, the id column is created as an identity column when creating table t1. The identity column automatically generated id column values, and the values are inserted when executing INSERT statement.

For more information, refer to **<identity column specification>** clause of **CREATE TABLE** statement.

The sequence and the identity column are functionally similar because they create the sequential numbers. However, they are different in the following aspects.

- Sequence is an SQL schema object but identity column is a column of the table.
- Sequence can be spanned multiple tables but identity column can be used only in one table.

After creating a sequence, the sequence values can be used by using **NEXTVAL** or **CURRVAL** function. The sequence value is created independently from the transaction, and it is not affected by COMMIT or ROLLBACK of the transaction.

```
gSQL> INSERT INTO t1(id) VALUES( seq.NEXTVAL );
1 row created.
gSQL> SELECT id FROM t1;
ID
--
 1
1 row selected.
gSQL> ROLLBACK;
Rollback complete.
gSQL> INSERT INTO t1(id) VALUES( seq.NEXTVAL );
1 row created.
gSQL> SELECT id FROM t1;
ID
--
 2
1 row selected.
```

In the example above, seq.NEXTVAL function generates a value of 1 in the first INSERT statement. Then, the seq.NEXTVAL value 2 is generated after the transaction ROLLBACK by increasing the value since the next value, independently from the transaction.

The sequence value can be used only in the following statements.

- The select list value of the top-level SELECT statement
  - SELECT seq.NEXTVAL FROM dual;
- The select list value of INSERT .. SELECT statement
  - INSERT INTO t1(id) SELECT seq.NEXTVAL FROM dual;
- Input value of INSERT .. VALUES statement
  - INSERT INTO t1(id) VALUES ( seq.NEXTVAL );
- SET value of UPDATE statement
  - UPDATE t1 SET id = seq.NEXTVAL;

The sequence value can be used only in the location as specified above. It can not be used in subquery, a aggregation function argument, or clauses such as WHERE, DISTINCT, GROUP BY, HAVING, ORDER BY.

## Cluster Sequence

When using GOLDLOCKS by configuring the cluster system, the global sequence object is internally used. The global sequence object sets the pool of sequence values to be commonly used over all cluster system, and allocates it as much as the cache size when each member node calls NEXTVAL. In other words, if values of 20 sequences are allocated to a specific node, then the value allocated to other nodes starts from the next value. A member node loads sequence values allocated by the global sequence object in its local cache, then returns them as a result of NEXTVAL call until all of them are run out.

The global sequence object has the following features and constraints comparing to the sequence for the standalone database.

- The sign can not be modified by using the INCREMENT BY option in the ALTER SEQUENCE statement. (The size can be modified.)
- When using the CYCLE option, a duplicated value can be returned to member nodes due to the size of the entire sequence pool. Therefore, if the CYCLE option is required, then the sequence pool should be set big enough considering INCREMENT BY, CACHE SIZE, and the number of cluster member nodes.
- Even when there is not an error, the sequence values returned by a specific member node may not be sequential. However, a sequential sequence value is obtained when only a single member node calls NEXTVAL.
- If it is NOCACHE, then the CACHE SIZE is 1, so the additional sequence values are not loaded on a local cache. In this case, the global sequence object allocates a single sequence whenever calling NEXTVAL, then it increases the networking cost and may cause the poor performance.
- It is generally operated as AUTO COMMIT when creating, altering and deleting the sequence.
- When modifying the size of CACHE and INCREMENT by using the ALTER statement, then all sequence values loaded on local caches of all nodes are reset. In other words, the new sequence set should be allocated again by the global sequence object when calling NEXTVAL later.

## 13.11 Synonym

### Synonym-related Statements

Statements for creating and dropping a synonym are as follows.

- Creating a synonym: Refer to **CREATE SYNONYM**.
- Dropping a synonym: Refer to **DROP SYNONYM**.

Information which is related to a synonym object can be retrieved through the following views.

**Table 13-22** Synonym object related information

| Schema            | View          | Description                          |
|-------------------|---------------|--------------------------------------|
| DICTIONARY_SCHEMA | ALL_SYNONYMS  | All synonym information              |
|                   | USER_SYNONYMS | Information about user owned synonym |

### Concepts of Synonym

Synonym is an alias for the following objects.

- Table
- View
- Sequence
- Stored procedure
- Stored function
- Other synonyms

Synonyms can be used as aliases in SELECT, INSERT, UPDATE, DELETE, LOCK TABLE, GRANT, REVOKE, COMMENT statements.

Using synonym is very convenient. It is because only the synonym should be redefined without modifying the application even when the schema of underlying objects is changed.

The database security can be improved by hiding the object's real name and its owner. Moreover, the database usability is enhanced by changing the long object name to a short name.

Synonyms are classified as private synonym and public synonym. Private synonym is a schema object and public synonym is a non-schema object.

The following examples of creating and using the private synonym and the public synonym indicated by t

The table below describes the concepts of them.

```
gSQL> \CONNECT u1 u1
gSQL> CREATE TABLE u1.t1 (col1 INTEGER );
gSQL> INSERT INTO u1.t1 VALUES(1);
gSQL> COMMIT;
```

## Private Synonym

Private synonym is a schema object. If a synonym is created without the schema name, the default schema name of the user performing the statement is used.

```
gSQL> \CONNECT u2 u2
gSQL> CREATE SYNONYM u2.syn1 FOR u1.t1;
Synonym created.
gSQL> SELECT * FROM u2.syn1;
ERR-42000(16254): lacks privilege (SELECT ON TABLE "U1"."T1")
```

Synonym is only an alias. Therefore, if a user does not have the appropriate privileges on the underlying object u1.t1, then the user can not use it even when the user created the synonym.

```
gSQL> \CONNECT u1 u1
gSQL> GRANT SELECT ON TABLE u2.syn1 TO u2;
gSQL> \CONNECT u2 u2
gSQL> SELECT * FROM u2.syn1;
COL1
----
  1
1 row selected.
gSQL> SELECT * FROM u1.t1;
COL1
----
  1
1 row selected.
gSQL> DROP SYNONYM u2.syn1;
Synonym dropped.
```

In the example above, the SELECT privilege of u2.syn1 is granted to u2. This is the same as the SELECT privilege of u1.t1 is granted to u2. Therefore, be cautious when granting privileges to synonyms.



## Public Synonym

Public synonym is a non schema object. It is not allowed to specify the schema name when it is created or dropped.

```
gSQL> \CONNECT u2 u2
gSQL> CREATE PUBLIC SYNONYM pubSyn1 FOR u1.t1;
Synonym created.
gSQL> SELECT * FROM pubSyn1;
ERR-42000(16254): lacks privilege (SELECT ON TABLE "U1"."T1")
```

Public synonym dose not have an owner, and it is accessible for all users. However, a user without an appropriate privilege on the underlying objects can not access the underlying objects.

```
gSQL> \CONNECT u1 u1
gSQL> GRANT SELECT ON TABLE pubSyn1 TO u2;
gSQL> \CONNECT u2 u2
gSQL> SELECT * FROM pubSyn1;
COL1
----
  1
1 row selected.
gSQL> SELECT * FROM u1.t1;
COL1
----
  1
1 row selected.
gSQL> DROP SYNONYM pubSyn1;
Synonym dropped.
```

## 13.12 Stored Procedure

### Stored Procedure-related Statements

Statements for creating, dropping and altering a stored procedure are as follows.

- Creating a stored procedure: Refer to **CREATE PROCEDURE**.
- Dropping a stored procedure: Refer to **DROP PROCEDURE**.
- Altering a stored procedure: Refer to **ALTER PROCEDURE**.

Information which is related to a stored procedure can be retrieved through the following views.

**Table 13-23** Stored procedure object related information

| Schema             | View                   | Description                                                                                         |
|--------------------|------------------------|-----------------------------------------------------------------------------------------------------|
| DICTIONARY_SCHEMA  | ALL_ARGUMENTS          | Argument information of user accessible procedure and function                                      |
|                    | ALL_DEPENDENCIES       | Information of an object related to user accessible procedure and function                          |
|                    | ALL_PROCEDURES         | Object information of user accessible procedure and function                                        |
|                    | ALL_SOURCE             | Source text information of user accessible procedure and function                                   |
|                    | USER_ARGUMENTS         | Argument information of user owned procedure and function                                           |
|                    | USER_DEPENDENCIES      | Information of an object related to user owned procedure and function                               |
|                    | USER_PROCEDURES        | Object information of user owned procedure and function                                             |
|                    | USER_SOURCE            | Source text information of user accessible procedure and function                                   |
| INFORMATION_SCHEMA | PARAMETERS             | Argument information of user accessible procedure and function                                      |
|                    | ROUTINES               | Object information of user accessible procedure and function                                        |
|                    | ROUTINE_ROUTINE_USAGE  | Information of procedure and function which is referenced by user accessible procedure and function |
|                    | ROUTINE_SEQUENCE_USAGE | Information of sequence which is referenced by user accessible procedure and function               |
|                    | ROUTINE_TABLE_USAGE    | Information of table and view which is referenced by user accessible procedure and function         |

### Concepts of Stored Procedure

A stored procedure is a kind of a persistent stored module in procedure form and it is defined and managed in schema unit as like other schema-level database objects. The return value is not defined because it is in procedure form. It is used by directly calling it in CALL statement, another stored procedure, or stored

function.

For more information about a stored procedure, refer to **Schema-level Procedure**.

A store procedure is used as follows.

```
CREATE OR REPLACE PROCEDURE PROC1( A1 INTEGER, A2 INTEGER )
IS
  V1 INTEGER;
BEGIN
  SELECT COUNT(*)
  INTO V1
  FROM T1
  WHERE T1.I1 >= A1 AND T1.I1 <= A2;
  DBMS_OUTPUT.PUT_LINE( 'V1 = ' || V1 );
END;
/
BEGIN
  PROC1( 2, 4 ); -- call schema-level procedure
END;
/
V1 = 3
Anonymous PL block executed.
```

## 13.13 Stored Function

### Stored Function-related Statements

Statements for creating, dropping and altering a stored function are as follows.

- Creating a stored function: Refer to **CREATE FUNCTION**.
- Dropping a stored function: Refer to **DROP FUNCTION**.
- Altering a stored function: Refer to **ALTER FUNCTION**.

Information which is related to a stored function can be retrieved through the following views.

**Table 13-24** Stored function object related information

| Schema             | View                   | Description                                                                                         |
|--------------------|------------------------|-----------------------------------------------------------------------------------------------------|
| DICTIONARY_SCHEMA  | ALL_ARGUMENTS          | Argument information of user accessible procedure and function                                      |
|                    | ALL_DEPENDENCIES       | Information of an object related to user accessible procedure and function                          |
|                    | ALL_PROCEDURES         | Object information of user accessible procedure and function                                        |
|                    | ALL_SOURCE             | Source text information of user accessible procedure and function                                   |
|                    | USER_ARGUMENTS         | Argument information of user owned procedure and function                                           |
|                    | USER_DEPENDENCIES      | Information of an object related to user owned procedure and function                               |
|                    | USER_PROCEDURES        | Object information of user owned procedure and function                                             |
|                    | USER_SOURCE            | Source text information of user accessible procedure and function                                   |
| INFORMATION_SCHEMA | PARAMETERS             | Argument information of user accessible procedure and function                                      |
|                    | ROUTINES               | Object information of user accessible procedure and function                                        |
|                    | ROUTINE_ROUTINE_USAGE  | Information of procedure and function which is referenced by user accessible procedure and function |
|                    | ROUTINE_SEQUENCE_USAGE | Information of sequence which is referenced by user accessible procedure and function               |
|                    | ROUTINE_TABLE_USAGE    | Information of table and view which is referenced by user accessible procedure and function         |

### Concepts of Stored Function

A stored function is a kind of a persistent stored module in function form and it is defined and managed in schema unit as like other schema-level database objects. The return value should be defined because it is in function form. It is used by directly calling it in CALL statement, another stored procedure, or stored f

unction. Or, it is use by calling it in a general SQL internal expression.

For more information about a stored function, refer to **schema-level function**.

A store function is used as follows.

```
gSQL> CREATE OR REPLACE FUNCTION FUNC1( A1 INTEGER, A2 INTEGER )
RETURN INTEGER
IS
  V1 INTEGER;
BEGIN
  SELECT COUNT(*)
  INTO V1
  FROM T1
  WHERE T1.I1 >= A1 AND T1.I1 <= A2;
  RETURN V1;
END;
/
Function created.
gSQL> SELECT FUNC1( 2, 4 ) FROM DUAL;
FUNC1( 2, 4 )
-----
              3
1 row selected.
```

## 13.14 Package

### Package-related Statement

Statements for creating, dropping and altering a package are as follows.

- Creating package: Refer to **CREATE PACKAGE**
- Creating package body: Refer to **CREATE PACKAGE BODY**
- Altering package: Refer to **ALTER PACKAGE**
- Dropping package: Refer to **DROP PACKAGE**

The information related to the package object can be retrieved through the following views.

**Table 13-25** Stored function object-related information.

| Schema            | View                      | Description                                                                                                             |
|-------------------|---------------------------|-------------------------------------------------------------------------------------------------------------------------|
| DICTIONARY_SCHEMA | ALL_OBJECTS               | It is the information about the object which is accessible by a user.                                                   |
|                   | ALL_PACKAGE_PRIVS         | It is the information about the privilege related to the user package.                                                  |
|                   | ALL_PACKAGE_PRIVS_MADE    | It is the information about the privilege which a user granted to allow access to the package.                          |
|                   | ALL_PACKAGE_PRIVS_RECD    | It is the information about the privilege which was granted to a user allow access to the package.                      |
|                   | ALL_SOURCE                | It is the information about the source text of procedure, function, package which are accessible by a user.             |
|                   | USER_OBJECTS              | It is the information about the user-owned object.                                                                      |
|                   | USER_PACKAGE_PRIVS        | It is the information about the privilege related to the user-owned package.                                            |
|                   | USER_PACKAGE_PRIVS_MADE   | It is the information about the privilege which granted to allow access to user-owned package.                          |
|                   | USER_PACKAGE_PRIVS_RECD   | It is the information about the privilege which was granted to allow access to user-owned package.                      |
|                   | USER_SOURCE               | It is the information about the source text of procedure, function, package which are owned by a user.                  |
|                   | MODULES                   | It is the information about SQL-server module (package) accessible by a user.                                           |
|                   | MODULE_BODY               | It is the information about package body accessible by a user.                                                          |
|                   | MODULE_BODY_MODULE_USAGE  | It is the information about another package which is being used by the package body accessible by a user.               |
|                   | MODULE_BODY_ROUTINE_USAGE | It is the information about the procedure or the function which is being used by the package body accessible by a user. |

| Schema             | View                       | Description                                                                                                            |
|--------------------|----------------------------|------------------------------------------------------------------------------------------------------------------------|
| INFORMATION_SCHEMA | MODULE_BODY_SEQUENCE_USAGE | It is the information about the sequence which is being used by the package body accessible by a user.                 |
|                    | MODULE_BODY_TABLE_USAGE    | It is the information about the table which is being used by the package body accessible by a user.                    |
|                    | MODULE_MODULE_USAGE        | It is the information about another package which is being used by the package accessible by a user.                   |
|                    | MODULE_PRIVILEGES          | It is the information about privilege related the package accessible by a user.                                        |
|                    | MODULE_ROUTINE_USAGE       | It is the information about the procedure or the function which is being used by the package accessible by a user.     |
|                    | MODULE_SEQUENCE_USAGE      | It is the information about the sequence which is being used by the package accessible by a user.                      |
|                    | MODULE_TABLE_USAGE         | It is the information about the table which is being used by the package accessible by a user.                         |
|                    | ROUTINE_MODULE_USAGE       | It is the information about the package being used by the procedure or by the function, which is accessible by a user. |
|                    | VIEW_MODULE_USAGE          | It is the information about the package which is being used by the view accessible by a user.                          |

## Concepts of Package

A package is a schema object which binds PSM type, a variable, a subprogram, a cursor, and an exception which are logically related. The package is stored in the database through compiling so that another program (another package, a procedure, an external program) to refer, share and execute the package items.

For more information about the package, refer to **PSM Packages**.

The following is an example of creating the package.

```
CREATE TABLE emp( empno NUMBER, sal NUMBER, comm NUMBER );
Table created.
INSERT INTO emp VALUES( 3548, 6000, 1000 );
1 row created.
INSERT INTO emp VALUES( 9369, 5000, NULL );
1 row created.
INSERT INTO emp VALUES( 7294, 4000, 500 );
1 row created.
COMMIT;
Commit complete.
```

```

CREATE OR REPLACE PACKAGE emp_mgmt
IS
  PROCEDURE adjust_sal(v_flag VARCHAR, v_empno NUMBER, v_pct NUMBER);
  FUNCTION get_annual_sal(v_empno NUMBER) RETURN NUMBER;
END;
/
Package created.
CREATE OR REPLACE PACKAGE BODY emp_mgmt
IS
  PROCEDURE adjust_sal(v_flag VARCHAR, v_empno NUMBER, v_pct NUMBER) IS
  BEGIN
    IF v_flag = 'INCREASE' THEN
      UPDATE emp SET sal = sal + (sal * (v_pct / 100)) WHERE empno = v_empno;
    ELSE
      UPDATE emp SET sal = sal - (sal * (v_pct / 100)) WHERE empno = v_empno;
    END IF;
  END;
END;
FUNCTION get_annual_sal (v_empno NUMBER) RETURN NUMBER
IS
  v_sal NUMBER;
BEGIN
  SELECT (sal + NVL(comm,0)) * 12 INTO v_sal FROM emp WHERE empno = v_empno;
  RETURN v_sal;
END;
END;
/
Package created.

```

The following is an example of using the package.

```

call emp_mgmt.adjust_sal('INCREASE',7369, 10);
Procedure Call complete.
SELECT emp_mgmt.get_annual_sal(7294) FROM DUAL;
EMP_MGMT.GET_ANNUAL_SAL(7294)
-----
                             54000
1 row selected.

```



**14.**

---

## **Cluster Objects**

## 14.1 Cluster System

### Cluster System Related Statements

For more information, refer to the followings.

- Expanding a cluster system
  - **CREATE CLUSTER GROUP**
  - **ALTER CLUSTER GROUP name ADD MEMBER**
- Controlling an inactive cluster member
  - **ALTER DATABASE DROP INACTIVE CLUSTER MEMBERS**
  - **ALTER SYSTEM JOIN DATABASE**
- Rebalancing data
  - **ALTER DATABASE REBALANCE**
  - **ALTER TABLE name REBALANCE**

Information which is related to a cluster system can be retrieved through the following views.

**Table 14-1** Cluster system related information

| Schema                  | View                 | Description                                                                          |
|-------------------------|----------------------|--------------------------------------------------------------------------------------|
| DICTIONARY_SCHEMA       | DBA_CLUSTER          | Object information of a cluster group and a cluster member which configure a cluster |
|                         | DBA_CLUSTER_COMMENTS | Comment information of a cluster group and a cluster member                          |
| PERFORMANCE_VIEW_SCHEMA | V\$CLUSTER_MEMBER    | Status information of a cluster member                                               |

### Concepts of Cluster System

GOLDILOCKS cluster system manages data of a single database by sharding or duplicating the data into several servers. Applications can be run on every server configuring a cluster system, and run in the same way as using a single database system regardless of a system configuration or a connected server.

GOLDILOCKS cluster system consists of one or more cluster groups, and a cluster group consists of one or more cluster members. It does not require a separate application server or a meta server, but applications are connected to a cluster member corresponding to a data server, and run.

Figure 1 3 x 2 cluster system

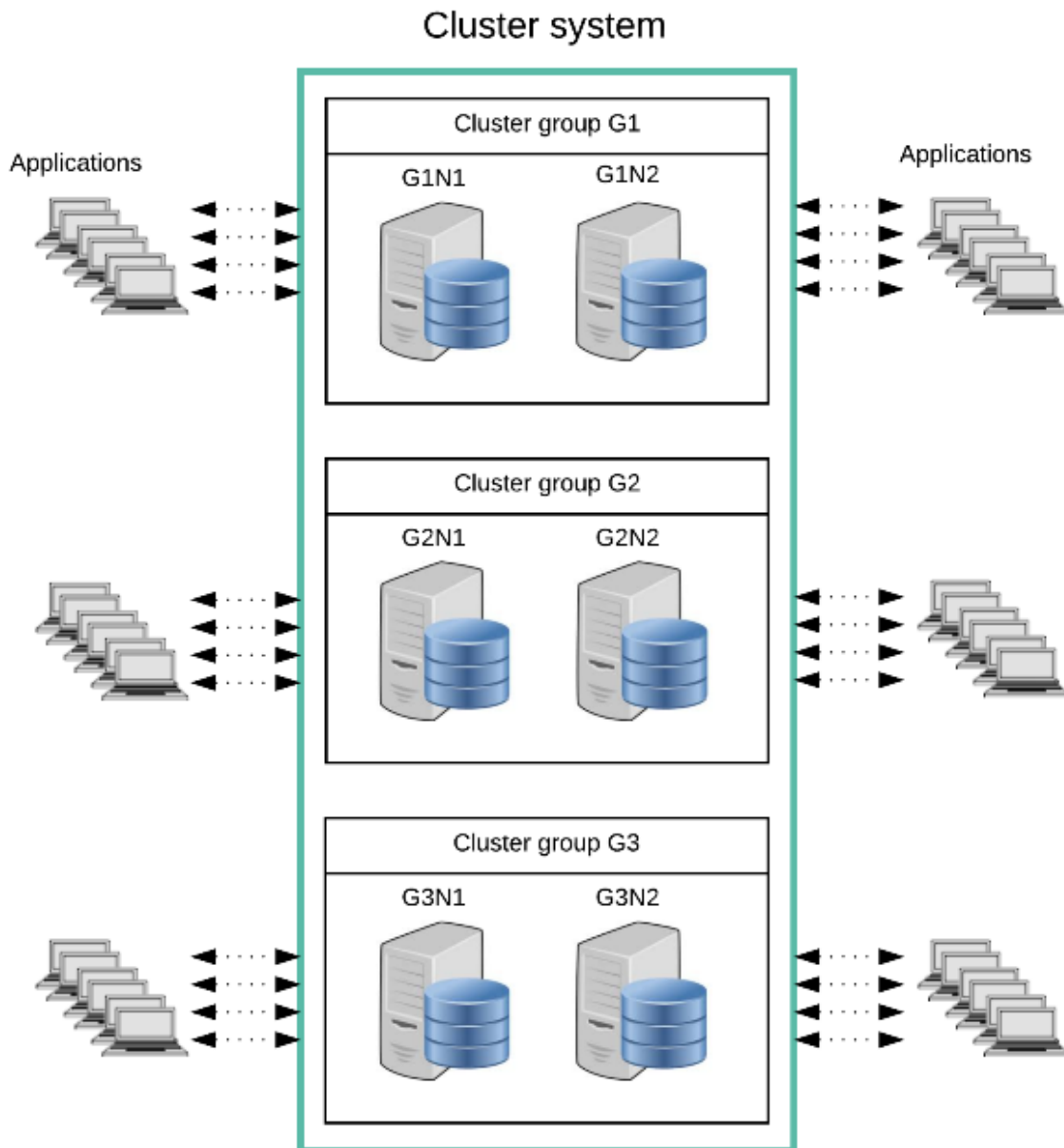

The figure above is a 3x2 cluster system which consists of two cluster members consisting of three cluster groups and a single cluster group. In the figure above, the cluster system consists of cluster groups (G1, G2, G3), and the cluster group G1 consists of cluster members (G1N1, G1N2), the cluster group G2 consists of cluster members (G2N1 and G2N2), and the cluster group G3 consists of cluster members (G3N1, G3N2). Applications can access any of those six cluster members and it is run as same as using a single database.

The table data is sharded and placed in each cluster group, and cluster members in a cluster group maintain the replications same. The figure below describes the concepts of the table data placement in a 3x2 cluster.

Figure 2 Concepts of sharding and duplicating by the cluster

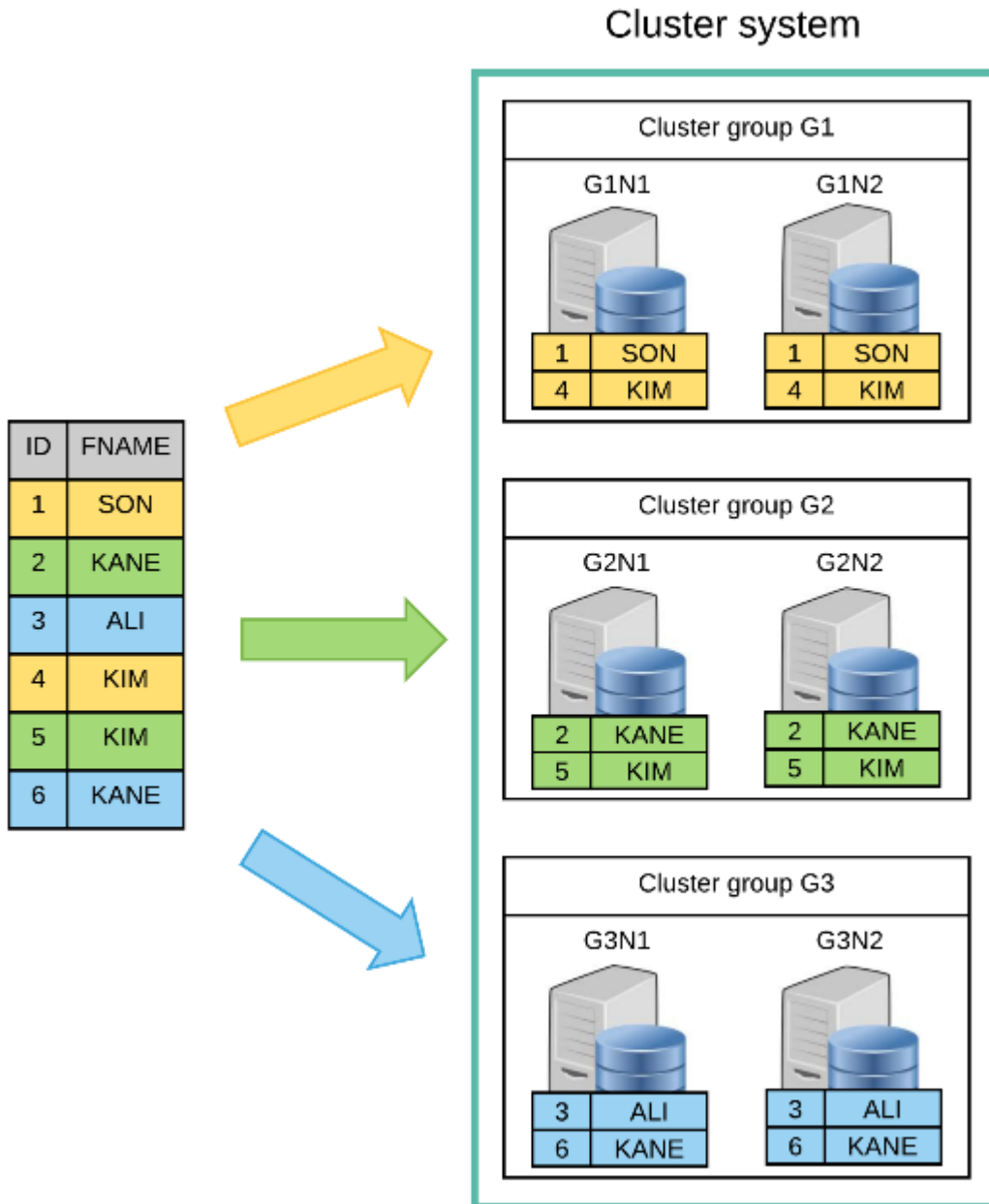

The table data is sharded and placed in each cluster group according to the sharding strategy defined by a user. (According to the ID column in the figure above) The placed data in a cluster group maintains the replication of a cluster member in a cluster group.

## Availability of Cluster System

Cluster continues to provide service even when a specific server is broken or the network is cut. Cluster members configuring each cluster group maintain the same data replications, so the service does not stop even when a single cluster member is broken. In other words, unless the data is lost due to the malfunction of all cluster members in a cluster group, the service continues to be provided.

The cluster continues to provide service even when three devices are broken in the 3x2 cluster as follows.

Figure 3 Cluster availability

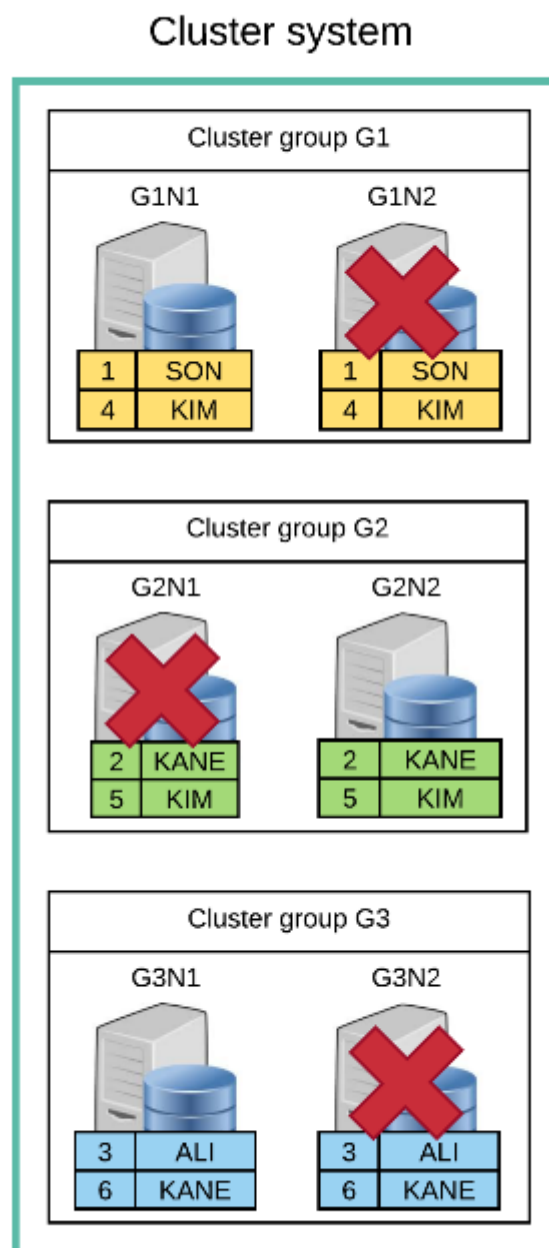

If additional errors occur in G1N1, G2N2, G3N1 in the situation above, then the data loss occurs and the service can not be provided any more. Therefore, a user should make the broken device to participate in a cluster system, or add a new cluster member before an additional error occurs.

- **ALTER SYSTEM JOIN DATABASE** statement is used to make the broken cluster member to participate in a cluster system again.
- **ALTER DATABASE DROP INACTIVE CLUSTER MEMBERS** statement is used to drop the broken cluster member from the cluster system.
- **ALTER CLUSTER GROUP name ADD MEMBER** statement is used to add a cluster member to a cluster group for the high availability.
- **ALTER DATABASE REBALANCE** statement and **ALTER TABLE name REBALANCE** statement are used to rebalance data to a newly added cluster member.

## Expanding Cluster System

The cluster can be expanded by adding a new server without stopping the service.

Cluster is expanded by adding a cluster member or a cluster group and by rebalancing the data to an created server.

The following is an example of expanding a 2x1 cluster to a 3x2 cluster.

**Figure 4** Expanding cluster system

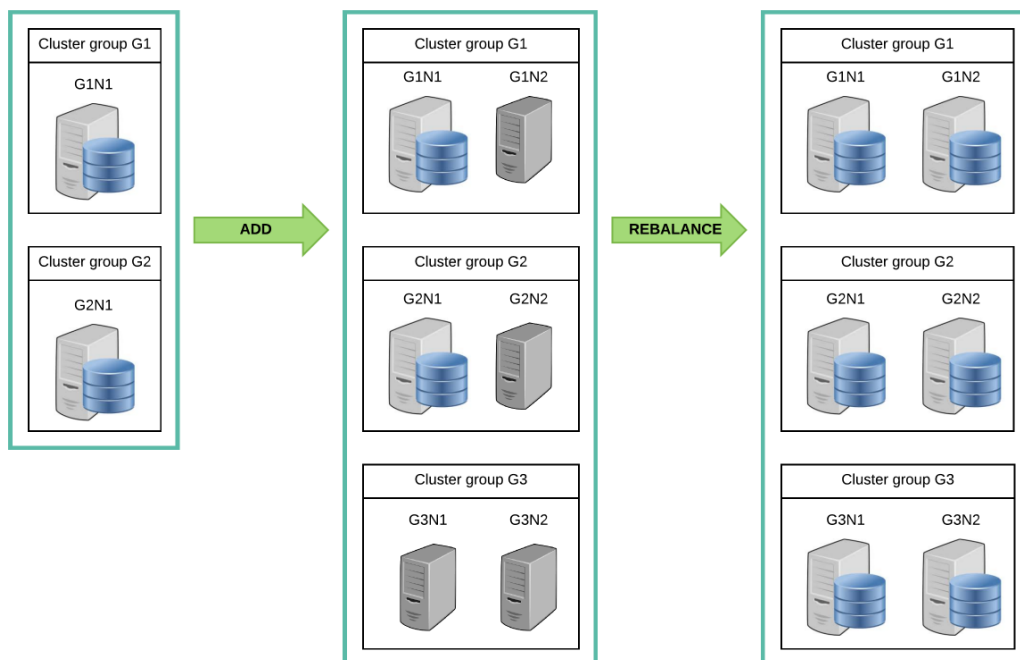

Add a cluster group and a cluster member by using the following statements to expand a cluster.

- **ALTER CLUSTER GROUP name ADD MEMBER**
- **CREATE CLUSTER GROUP**

To add a new cluster member to the cluster system, tablespaces in the cluster member and those in the cluster system should be same. In other words, tablespaces as same as all tablespaces in the cluster system should be created in the cluster member.

The following is an example of adding a cluster group and a cluster member of the 3x2 cluster to the 2x1 cluster. Add the member G1N2 to the group G1, and add the member G2N2 to the group G2. Then, create the group G3 including the members (G3N1, G3N2).

- Add the member G1N2 to the group G1.

```
gSQL>
ALTER CLUSTER GROUP G1
      ADD CLUSTER MEMBER G1N2 HOST '192.168.0.12' PORT 10120;
Cluster Group altered.
```

- Add the member G2N2 to the group G2.

```
gSQL>
ALTER CLUSTER GROUP G2
      ADD CLUSTER MEMBER G2N2 HOST '192.168.0.22' PORT 10220;
Cluster Group altered.
```

- Create the group G3.

```
gSQL>
CREATE CLUSTER GROUP G3
      CLUSTER MEMBER G3N1 HOST '192.168.0.31' PORT 10310,
      CLUSTER MEMBER G3N2 HOST '192.168.0.32' PORT 10320;
Cluster Group created.
```

The cluster group and the cluster member which are newly added to the cluster system can provide the service by synchronizing the dictionary information of the SQL object. However, the data is not yet placed in the added cluster member, so the availability can not be increased nor can the load balancing be expected. Therefore, the data should be rebalanced to the created cluster member for the high availability and the load balancing.

Use the following statements sequentially to rebalance the data.

- **ALTER DATABASE REBALANCE**

- **ALTER TABLE name REBALANCE**

The following is an example of rebalancing data to all tables in the database.

```
gSQL> ALTER DATABASE REBALANCE;  
Database altered.
```



## 14.2 Cluster Group

### Cluster Group Related Statements

For more information about creating, dropping, and altering a cluster group, refer to the followings.

- Creating a cluster group: **CREATE CLUSTER GROUP**
- Dropping a cluster group: **DROP CLUSTER GROUP**
- Altering a cluster group: **ALTER CLUSTER GROUP name ADD MEMBER**

Information which is related to a cluster group can be retrieved through the following views.

**Table 14-2** Cluster group related information

| Schema                | View                     | Description                                                                                |
|-----------------------|--------------------------|--------------------------------------------------------------------------------------------|
| DICTIONARY_SCH<br>EMA | DBA_CLUSTER              | Object information of a cluster group and a cluster member which c<br>onfigure the cluster |
|                       | DBA_CLUSTER_COM<br>MENTS | Comment information of a cluster group and a cluster member                                |

### Concepts of Cluster Group

At least one cluster group should be created to run the cluster system.

#### Creating Cluster Group

The first created cluster group should include itself as a cluster member. For more information about creating a cluster group, refer to **CREATE CLUSTER GROUP**.

A cluster member is a physical concept meaning the data server, but a cluster group is a logical concept consisting of one or more cluster members.

The availability and load balancing of the cluster system depend on the configuration of the cluster group. The more cluster members the cluster group includes the higher the availability. The more the number of the cluster groups the bigger the throughput of the cluster system because the data is distributed.

All cluster members in a cluster group maintain the same data replications, so it can continuously provide the service unless an error occurs in all cluster members configuring a cluster group. It is recommended to configure the cluster group with two or more cluster members to maintain the availability of the cluster.

r system.

The table data is sharded according to the sharding strategy, and it is stored and managed in each different cluster group according to the shard placement strategy. An appropriate table sharding strategy and the placement strategy according to the service feature determines the entire system performance. Each transaction and query is processed focusing on a cluster group in which the data is stored, so the performance is improved if the referenced data exist in the same cluster group.

## Dropping Cluster Group

The cluster group participating in a cluster system and providing a service can be dropped for various reasons. For more information about dropping the cluster group, refer to **DROP CLUSTER GROUP**.

To drop the cluster group, all shards in a sharded table which is created in that cluster group should be transferred to another cluster group. It should be transferred separately according to cluster-wide, group-specific table.

## 14.3 Cluster Member

### Cluster Member Related Statements

For more information, refer to the followings.

- Adding a cluster member: **ALTER CLUSTER GROUP name ADD MEMBER**
- Dropping a cluster member: **ALTER DATABASE DROP INACTIVE CLUSTER MEMBERS**
- Controlling a cluster member
  - **ALTER SYSTEM JOIN DATABASE**
  - **ALTER CLUSTER GROUP name OFFLINE MEMBER**
  - **ALTER DATABASE RESET LOCAL CLUSTER MEMBER**

Information which is related to a cluster member can be retrieved through the following views.

**Table 14-3** Cluster member related information

| Schema                  | View                 | Description                                                                          |
|-------------------------|----------------------|--------------------------------------------------------------------------------------|
| DICTIONARY_SCHEMA       | DBA_CLUSTER          | Object information of a cluster group and a cluster member which configure a cluster |
|                         | DBA_CLUSTER_COMMENTS | Comment information of a cluster group and a cluster member                          |
| PERFORMANCE_VIEW_SCHEMA | V\$CLUSTER_MEMBER    | Status information of a cluster member                                               |

### Concepts of Cluster Member

The cluster member is a server configuring a cluster system, and it maintains the replications as same as those of cluster member in a cluster group.

The cluster member is a data server storing a part of the cluster database data, and it is also an application server processing the connection and request of an application. Moreover, it is a meta server duplicating and managing the meta information. In other words, GOLDILOCKS cluster does not require any data server, application server, or meta server.

Cluster members which belong to the same cluster group have the same data replications. Therefore, an error in a specific cluster member does not cause an error in the entire system. It is recommended to include two or more cluster members in each cluster group for the high availability of the system. A single cluster group can be configured with maximum 32 cluster members.

Perform **ALTER CLUSTER GROUP name ADD MEMBER** statement to add a new cluster member to a cluster group.

The added cluster member maintains the meta information of the SQL object as same as that in the cluster system, so it can process the connection and request of the application. However, the data is not placed, so adding a cluster member does not guarantee the high availability of the cluster group.

Perform the following statements to place the data after adding a cluster member.

- For rebalancing the entire data: Refer to **ALTER DATABASE REBALANCE**.
- For rebalancing only a part of the table: Refer to **ALTER TABLE name REBALANCE**.

When an error occurs on a cluster member, service is continuously provided but DDL can not be performed. For a normal service operation, an appropriate action should be taken for the cluster member with an error.

To make the cluster member with an error to participate in the cluster system again, then perform **ALTER SYSTEM JOIN DATABASE** statement after connecting to the cluster member and driving up to the LOCAL OPEN phase.

Even when a part of cluster members are not driven or the cluster system is driven while the network is disconnected, perform **ALTER SYSTEM JOIN DATABASE** statement after driving up the cluster member to the LOCAL OPEN phase.

If the cluster member device with an error can not be restored, then drop that cluster member by performing **ALTER DATABASE DROP INACTIVE CLUSTER MEMBERS** statement in the cluster system.

The cluster member dropped from the cluster system still includes the previous information, and it can not participate in the cluster system again. Perform **ALTER DATABASE RESET LOCAL CLUSTER MEMBER** statement to reset the cluster member to when it is before participating in the cluster system.

The statement above is different from newly creating the database of the cluster member because it maintains the tablespace information. Therefore, it can shorten the time to create the tablespace when adding a new cluster member to the cluster system.

## 14.4 Cluster Location

### Cluster Location Related Statements

For more information about creating, dropping, and altering a cluster location, refer to the followings.

- Creating a cluster location: **CREATE CLUSTER LOCATION**
- Dropping a cluster location: **DROP CLUSTER LOCATION**
- Altering a cluster location: **ALTER CLUSTER LOCATION**

Information which is related to a cluster location can be retrieved through the following views.

**Table 14-4** Cluster location related information

| Schema                  | View                | Description                     |
|-------------------------|---------------------|---------------------------------|
| PERFORMANCE_VIEW_SCHEMA | V\$CLUSTER_LOCATION | Information of cluster location |

### Concepts of Cluster Location

Cluster location is a connection information to connect the internal cluster networks of each cluster member registered on the cluster system. Each cluster members use the cluster-exclusive tcp network to transfer and receive various protocols such as the transaction processing and the exchanging the management information. In this case, the member name, host ip address, and port are used for the connection and they are called as a cluster location by the lump.

A unique cluster location information should be specified for each member, and if the information is duplicate, then the cluster network connection fails and the cluster system does not operate normally.

Cluster location information is automatically added or deleted when adding or dropping a cluster member, so a user rarely need to directly and solely add or delete the location information. However, DDL statement related to the cluster location can be used in the following case.

- When the cluster location information is lost due to the deleted location control file: **CREATE CLUSTER LOCATION**
- When the previously registered connection information of the cluster member is altered, which means that the hardware or the connected ip and port is altered: **ALTER CLUSTER LOCATION**

## 14.5 Cluster Table and Shard

### Shard Related Statements

For more information about definition and rebalance of the shard, refer to the followings.

- Definition of a shard: <table sharding strategy> clause of **CREATE TABLE**.
- Rebalancing a shard: **ALTER TABLE name REBALANCE**

Information which is related to a shard in a cluster table can be retrieved through the following views.

**Table 14-5** Shard in a cluster table related information

| Schema            | View                   | Description                                                   |
|-------------------|------------------------|---------------------------------------------------------------|
| DICTIONARY_SCHEMA | ALL_CLUSTER_TABLES     | Information of user accessible cluster table                  |
|                   | ALL_SHARD_KEY_COLUMNS  | Shard key column information of user accessible cluster table |
|                   | ALL_TAB_PLACE          | Placement information of user accessible cluster table        |
|                   | ALL_TAB_SHARDS         | Shard information of user accessible cluster table            |
|                   | USER_CLUSTER_TABLES    | Information of user owned cluster table                       |
|                   | USER_SHARD_KEY_COLUMNS | Shard key column information of user owned cluster table      |
|                   | USER_TAB_PLACE         | Placement information of user owned cluster table             |
|                   | USER_TAB_SHARDS        | Shard information of user owned cluster table                 |

### Cluster Table Type

A table which is created by a user in a cluster environment is one of the followings.

- Cloned table: Equally duplicating the table data and managing it
- Sharded table: Horizontally sharding the table data and managing it

A cloned table is appropriate for a table such as a product list or a provider list whose data is relatively small and is not often altered, because a cloned table duplicates all table data and manages it. When inserting, deleting, updating data to the cloned table, they are applied same to all cluster members to which the cloned table is placed.

A sharded table is appropriate for a table such as a transaction history or a call history whose data is big so required to be sharded. They are classified according to three sharding strategies as follows.

- Hash sharded table
  - It divides the table data into several shards based on the hash value of a sharding key, then places them in the cluster system.
- Range sharded table
  - It divides the table data into several shards based on the range value of a sharding key, then places them in the cluster system.
- List sharded table
  - It divides the table data into several shards based on the list value of a sharding key, then places them in the cluster system.

A sharded table horizontally divides rows and manages them in shard unit, the sharding strategy is defined by using the SHARDING BY clause in **CREATE TABLE** statement. The row set classified by the sharding strategy is called as shard.

Each shard is placed in a cluster group according to the placement strategy defined by a user. A shard can automatically be placed by using AT CLUSTER WIDE of **CREATE TABLE**, or a cluster group to place a shard can be specified by using AT CLUSTER GROUP clause. When a shard is automatically placed by using AT CLUSTER WIDE, **ALTER TABLE name REBALANCE** is performed after creating the cluster group by using **CREATE CLUSTER GROUP**. However, when specifying a cluster group to allocate a shard using AT CLUSTER GROUP, the shard is not placed in the newly created cluster group.

The following is an example of creating a table according to the cluster table type and placing the data in the 3x2 cluster environment.

## Cloned Table

A cloned table equally duplicates the table data and manages it.

The following is an example of creating a cluster-wide cloned table. All table data is equally duplicated and placed in 3x2 cluster members.

```
CREATE TABLE t1 ( id INTEGER )
  CLONED
  AT CLUSTER WIDE
;
```

Figure 5 Cluster-wide cloned table

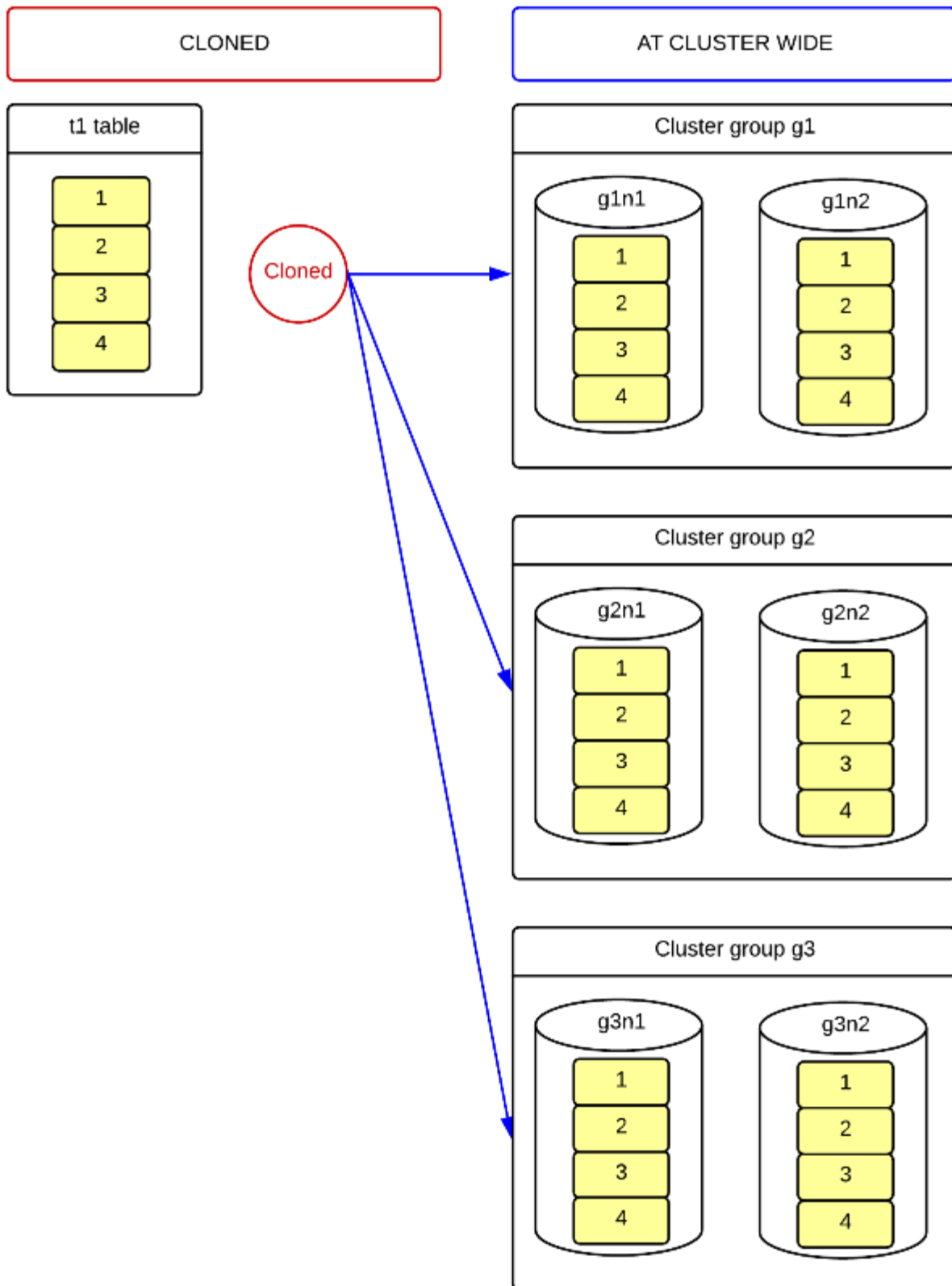

The following is an example of creating a group-specific cloned table. All table data is equally duplicated



and managed, but the duplicated table data exists only in cluster members of group g1 and g2 which are specified by a user, but it does not exist in a group g3.

```
CREATE TABLE t1 ( id INTEGER )  
  CLONED  
  AT CLUSTER GROUP g1, g2  
;
```

Figure 6 Group-specific cloned table

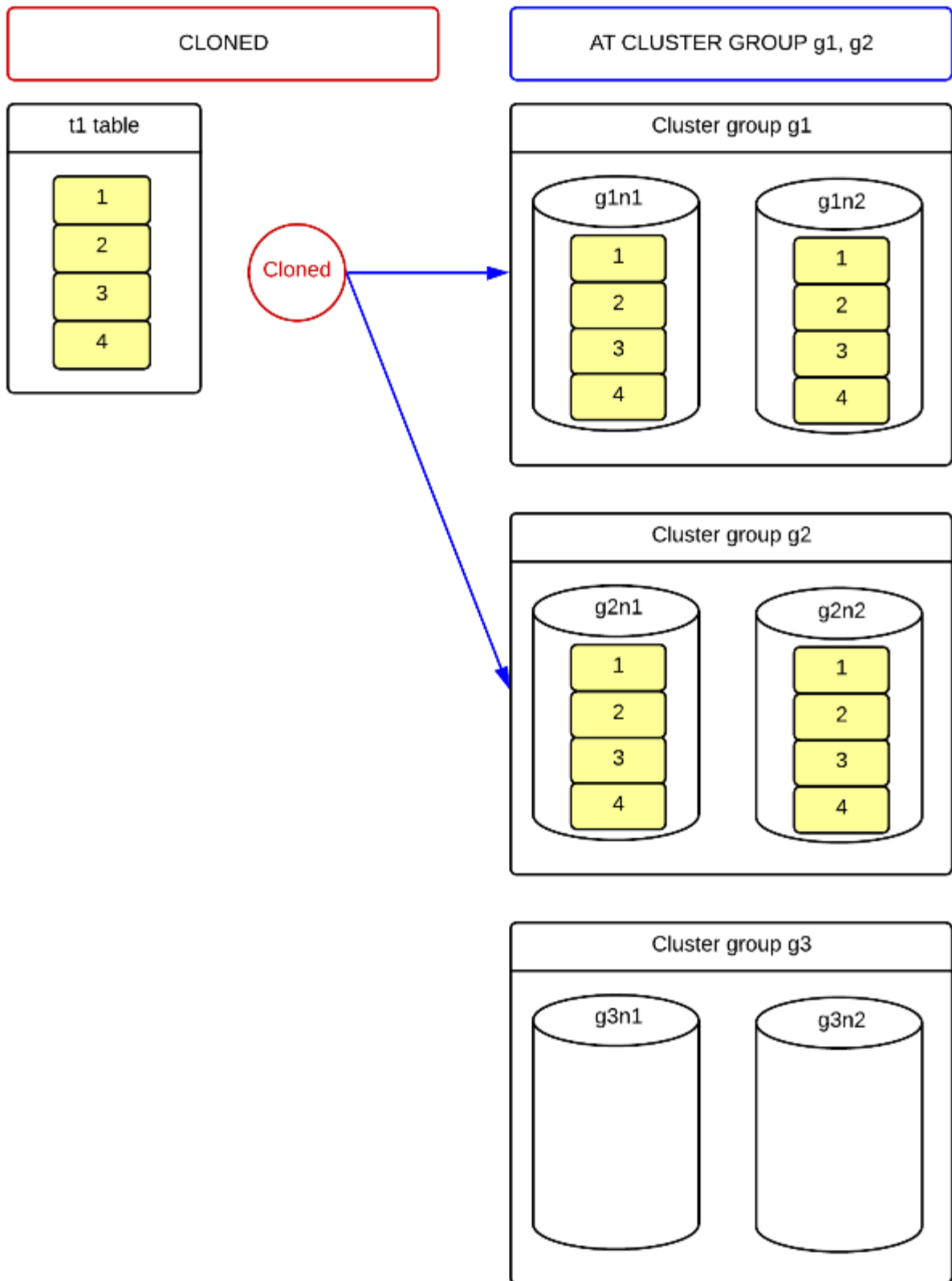

## Hash-sharded table

A hash-sharded table divides the table data into several shards based on the hash value of a sharding key, then places them in the cluster system.

The following is an example of creating the cluster-wide hash-sharded table. When adding data to a table, the hash value is created based on the ID column value, and the shard to place row is selected among five shards by using the hash value. Each shard is automatically placed. All rows with the same ID column value are included in the same shard, and placed in the same cluster group.

```
CREATE TABLE t1 ( id INTEGER )  
  SHARDING BY HASH(id)  
  SHARD COUNT 5  
  AT CLUSTER WIDE  
;
```

Figure 7 Cluster-wide hash-sharded table

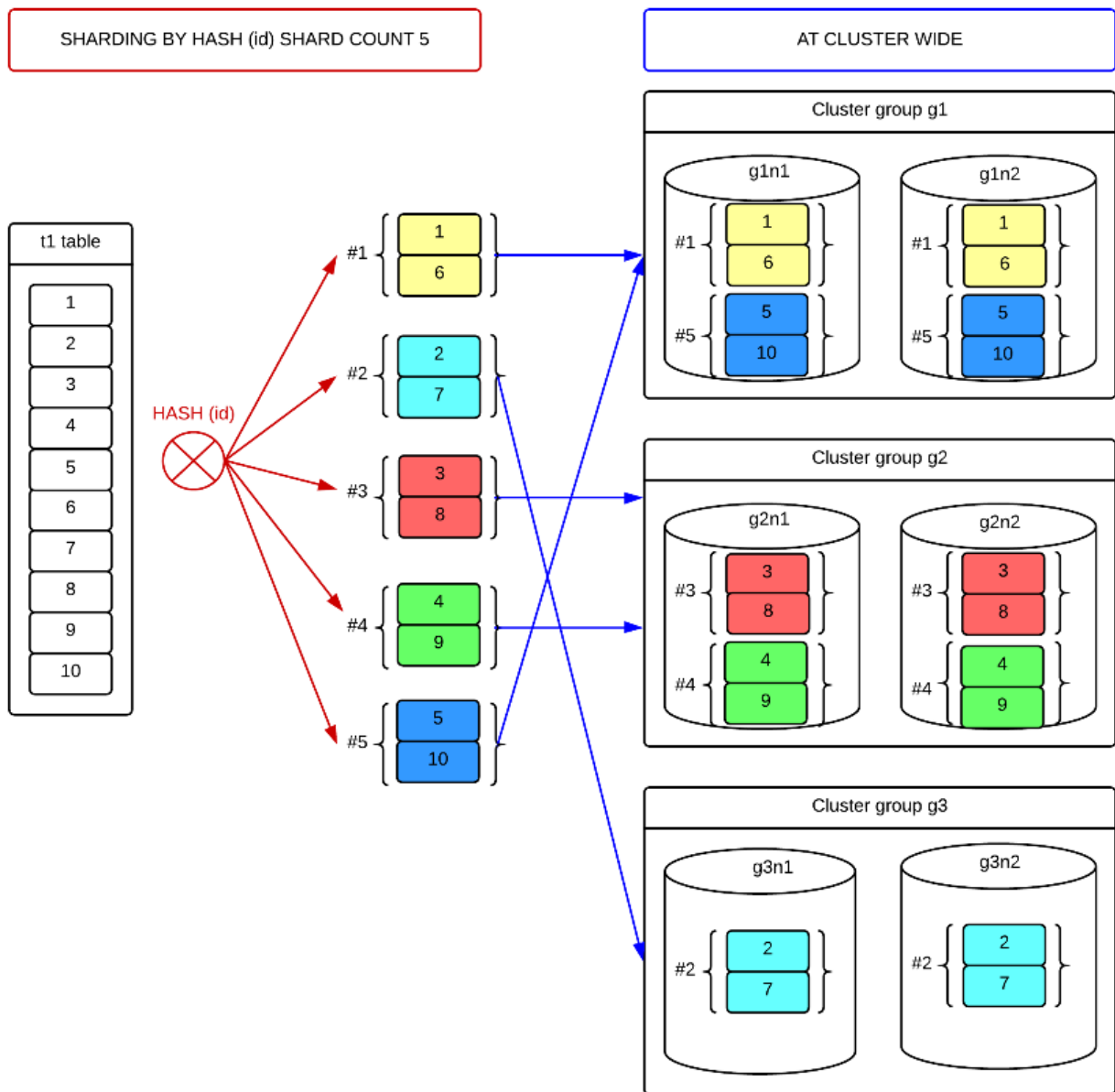

The following is an example of creating the group-specific hash-sharded table. The hash value of an ID column determines the shard, but each shard is placed only in the cluster group g1 and g2 which are specified by a user.

```
CREATE TABLE t1 ( id INTEGER )
  SHARDING BY HASH(id)
  SHARD COUNT 5
  AT CLUSTER GROUP g1, g2
;
```

Figure 8 Group-specific hash-sharded table

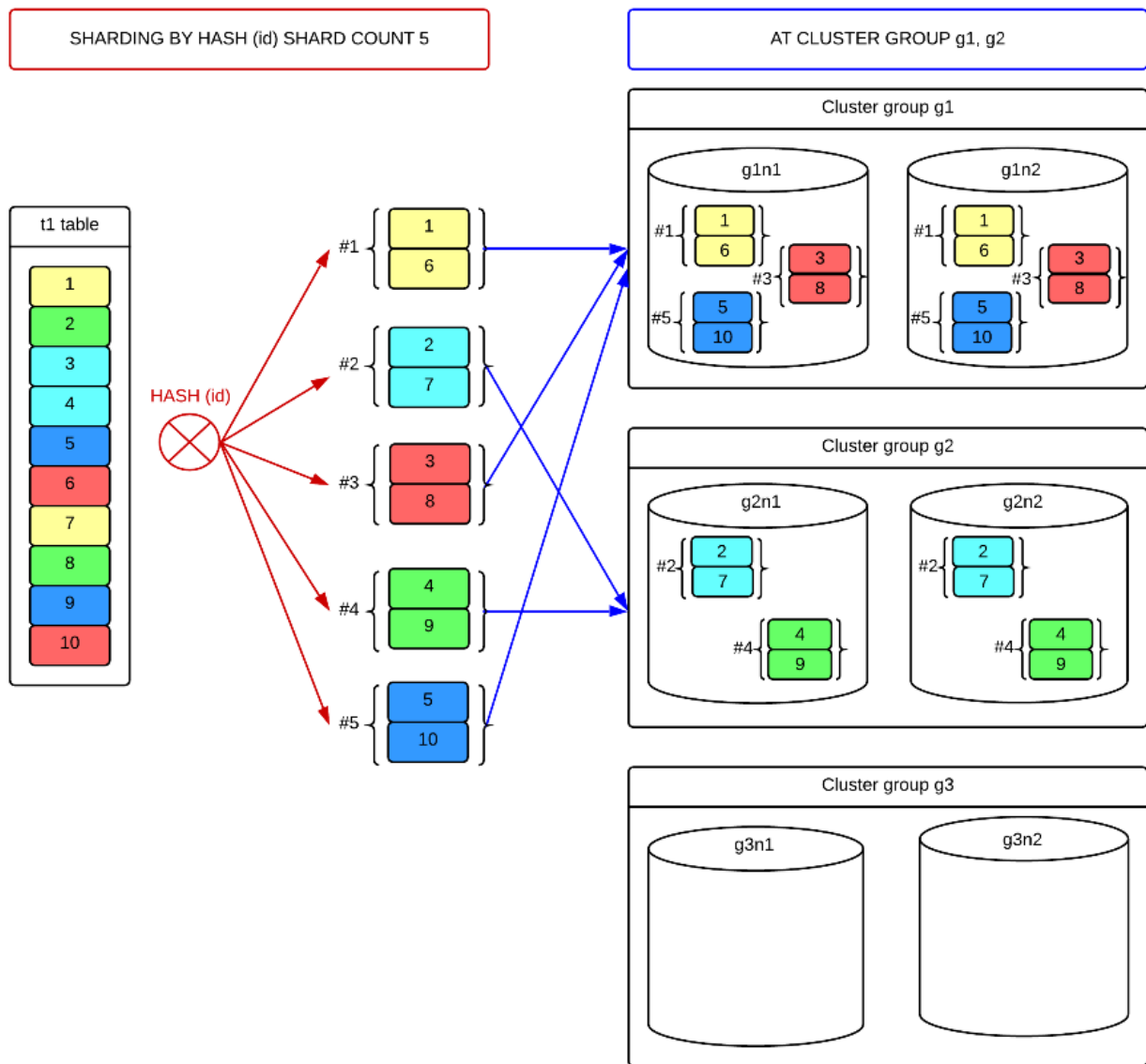

## Range-sharded Table

A range-sharded table divides the table data into several shards based on the range value of a sharding key, then places them in the cluster system.

The following is an example of creating the cluster-wide range-sharded table. When adding data to a table, the shard to place row is selected among five shards based on the range value of the ID column. Each shard is automatically placed. All rows of the ID column within the same range are included in the same shard, and placed in the same cluster group.

```

CREATE TABLE t1 ( id INTEGER )
SHARDING BY RANGE(id)
AT CLUSTER WIDE
  SHARD s1 VALUES LESS THAN ( 20 ),
  SHARD s2 VALUES LESS THAN ( 40 ),
  SHARD s3 VALUES LESS THAN ( 60 ),
  SHARD s4 VALUES LESS THAN ( 80 ),
  SHARD s5 VALUES LESS THAN ( MAXVALUE )
;
    
```

Figure 9 Cluster-wide range-sharded table

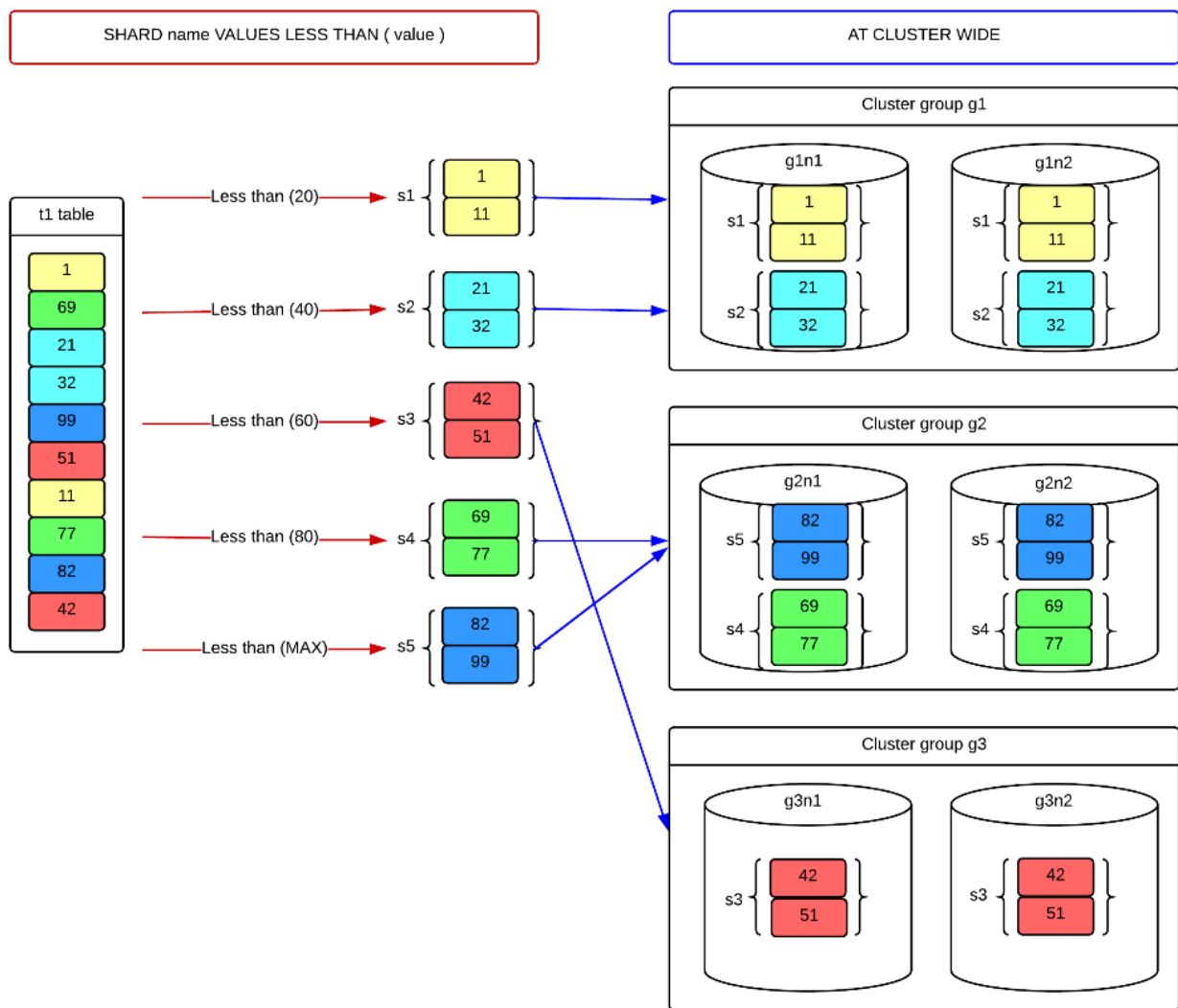

The following is an example of creating the group-specific range-sharded table. The range value of the ID column defines the shard, but each shard is placed in a cluster group specified by a user.

```

CREATE TABLE t1 ( id INTEGER )
  SHARDING BY RANGE(id)
    SHARD s1 VALUES LESS THAN ( 20 )      AT CLUSTER GROUP g1,
    SHARD s2 VALUES LESS THAN ( 40 )      AT CLUSTER GROUP g2,
    SHARD s3 VALUES LESS THAN ( 60 )      AT CLUSTER GROUP g1,
    SHARD s4 VALUES LESS THAN ( 80 )      AT CLUSTER GROUP g2,
    SHARD s5 VALUES LESS THAN ( MAXVALUE ) AT CLUSTER GROUP g3
;

```

Figure 10 Group-specific range-sharded table

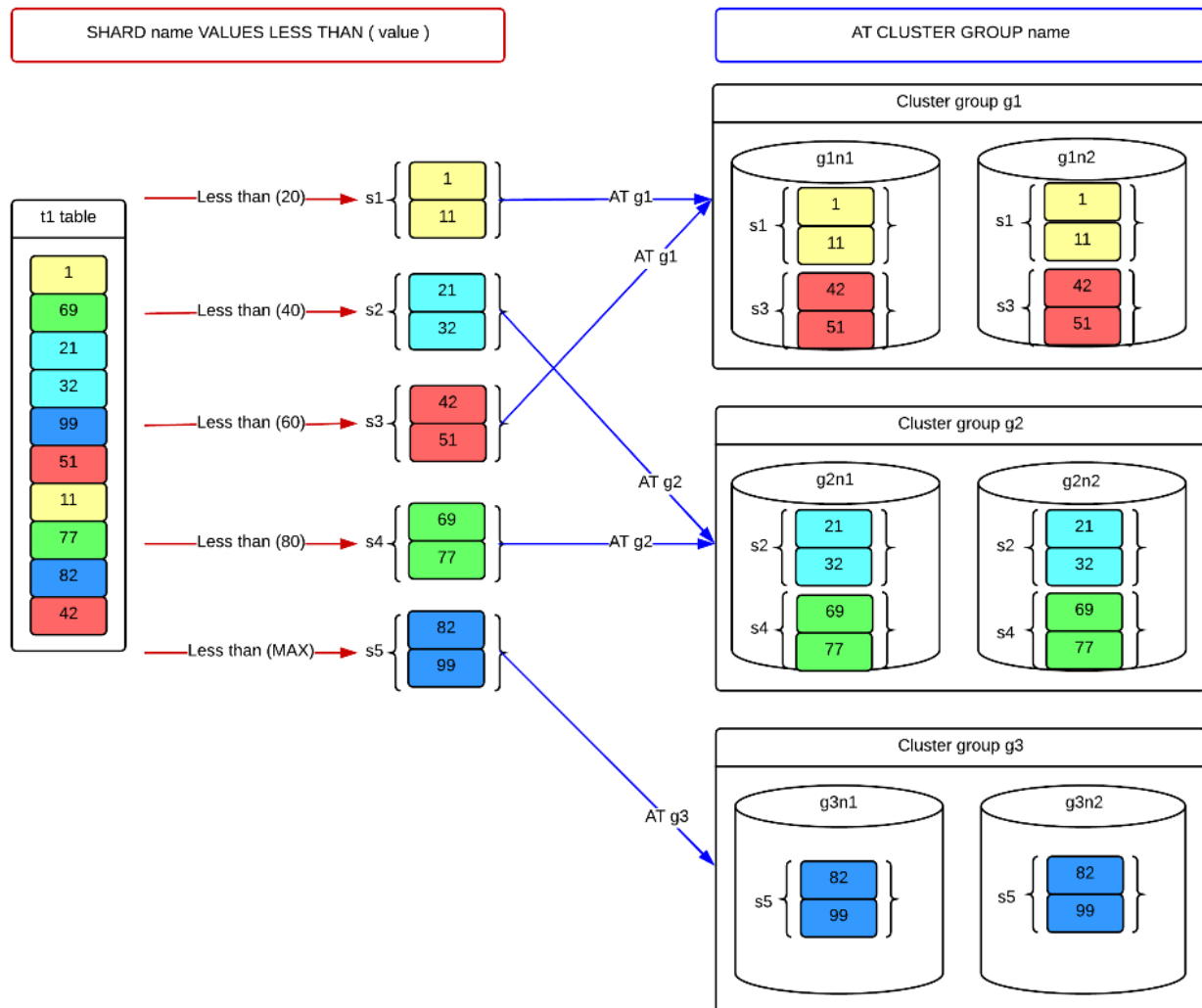

## List-sharded Table

A list-sharded table divides the table data into several shards based on the list value of a sharding key, then places them in the cluster system.

The following is an example of creating the cluster-wide list-sharded table. When adding data to a table, rows are placed in a shard with the list value as same as the CITY column value. Each shard is automatically placed.

```
CREATE TABLE t1 ( city VARCHAR(128) )
  SHARDING BY LIST (city)
  AT CLUSTER WIDE
  SHARD s1 VALUES IN ( 'seoul' ),
  SHARD s2 VALUES IN ( 'busan', 'ulsan' ),
  SHARD s3 VALUES IN ( 'suwon', 'ansan', 'osan' ),
  SHARD s4 VALUES IN ( 'goyang', 'paju', 'guri' ),
  SHARD s5 VALUES IN ( DEFAULT )
;
```

Figure 11 Cluster-wide list-sharded table

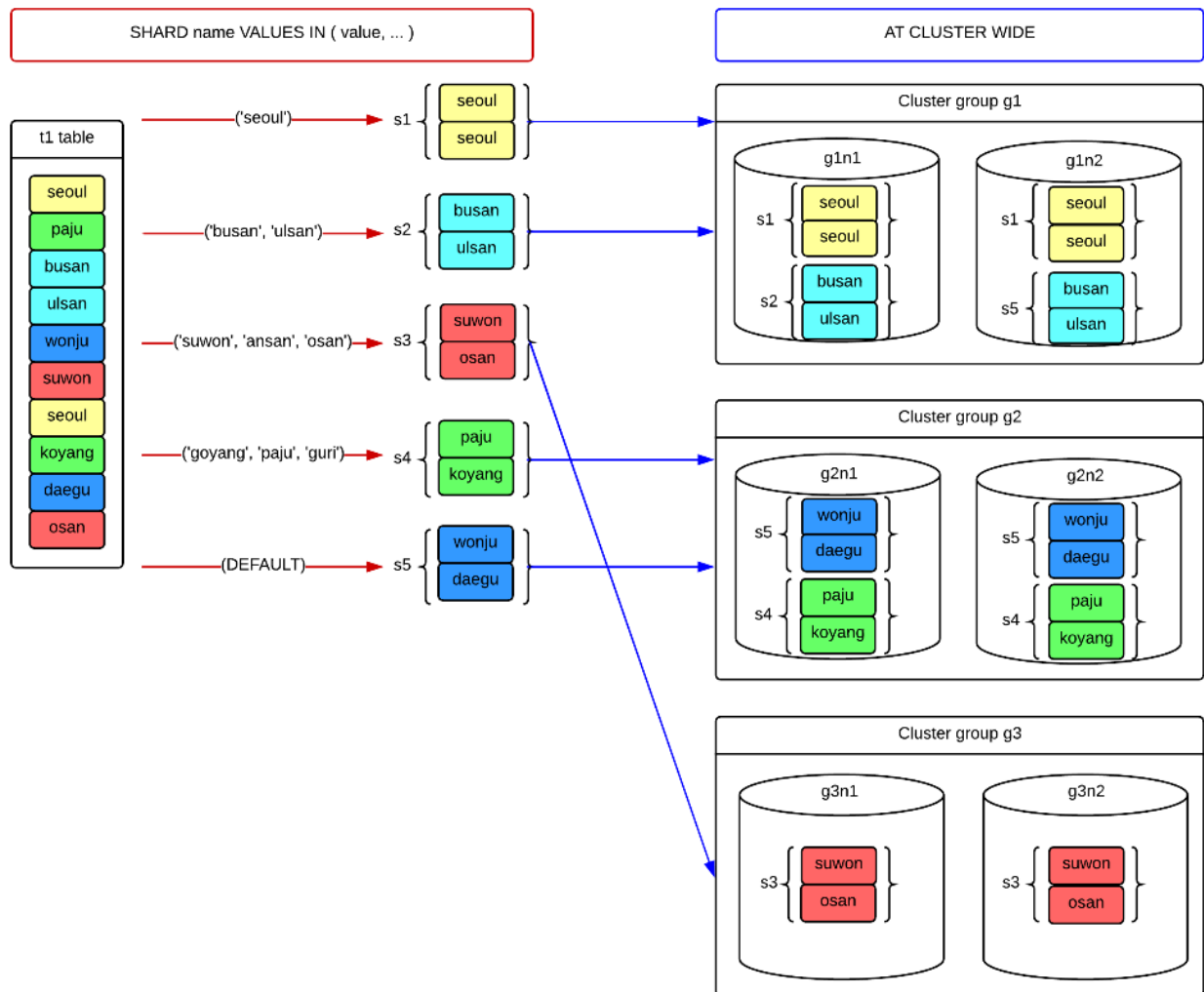

The following is an example of creating the group-specific list-sharded table. The shard is selected by the l



ist value of the CITY column, but each shard is placed in the cluster group specified by a user.

```

CREATE TABLE t1 ( city VARCHAR(128) )
  SHARDING BY LIST (city)
  SHARD s1 VALUES IN ( 'seoul' )           AT CLUSTER GROUP g1,
  SHARD s2 VALUES IN ( 'busan', 'ulsan' )  AT CLUSTER GROUP g2,
  SHARD s3 VALUES IN ( 'suwon', 'ansan', 'osan' ) AT CLUSTER GROUP g1,
  SHARD s4 VALUES IN ( 'goyang', 'paju', 'guri' ) AT CLUSTER GROUP g2,
  SHARD s5 VALUES IN ( DEFAULT )          AT CLUSTER GROUP g3
;

```

Figure 12 Group-specific list-sharded table

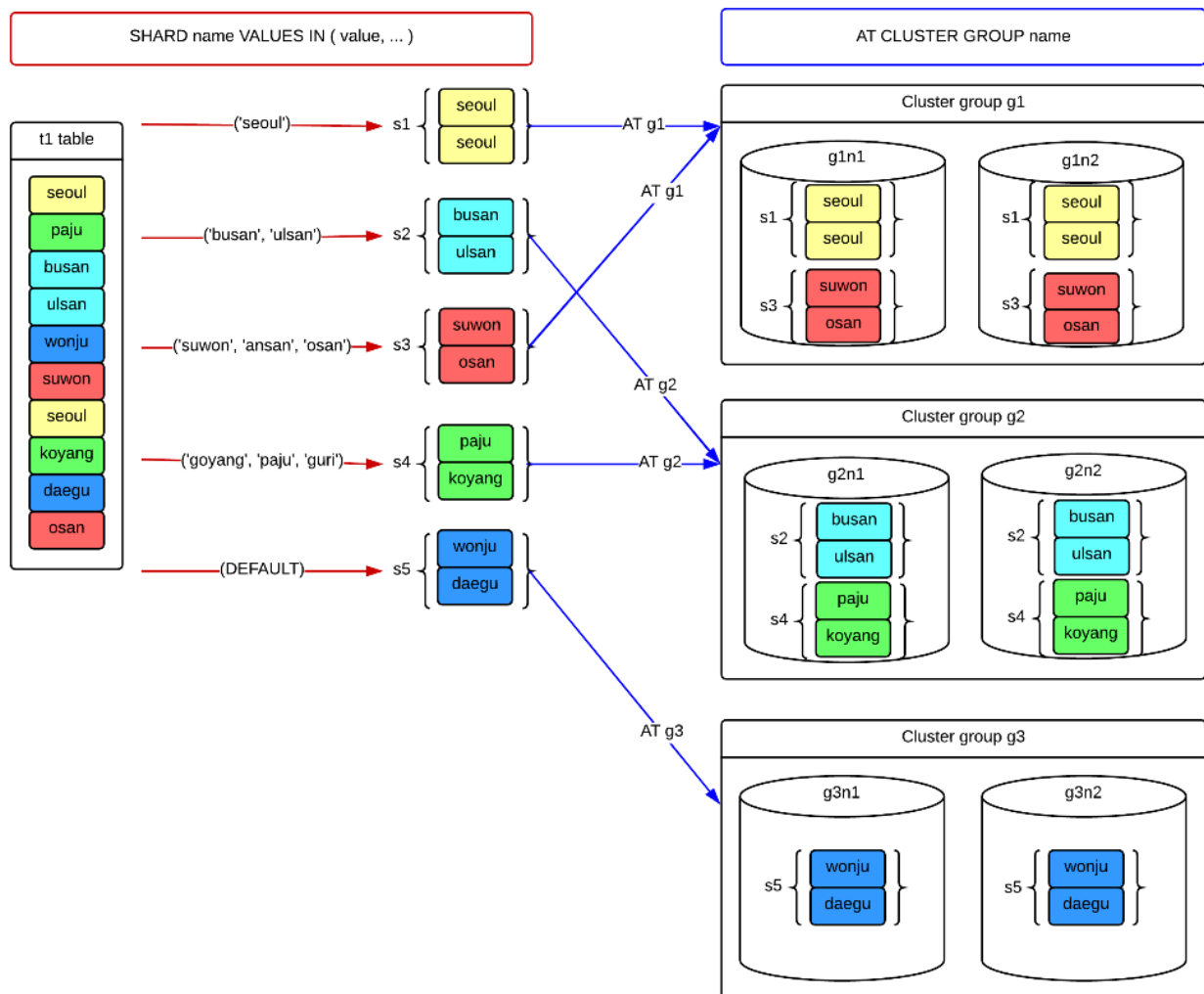

## Rebalancing Cluster Table

Rebalance the data of the cluster table by using **ALTER TABLE name REBALANCE** statement.

Data of the cluster table is rebalanced in the following unit.

- Cloned table: The entire table
- Sharded table: shard unit

If the table is specified as **AT CLUSTER WIDE**, the shard is automatically rebalanced to the created cluster group, but if the cluster group to place the shard is specified by **AT CLUSTER GROUP**, the shard is not rebalanced to the created cluster group.

- When automatically rebalancing by using **AT CLUSTER WIDE**, then the data can be rebalanced to a new cluster group and a new cluster member.

```
CREATE TABLE region
(
  r_regionkey  INTEGER
, r_name      CHAR(25)
, r_comment   VARCHAR(152)
)
CLONED
AT CLUSTER WIDE;
```

Figure 13 Rebalancing the region table defined by AT CLUSTER WIDE

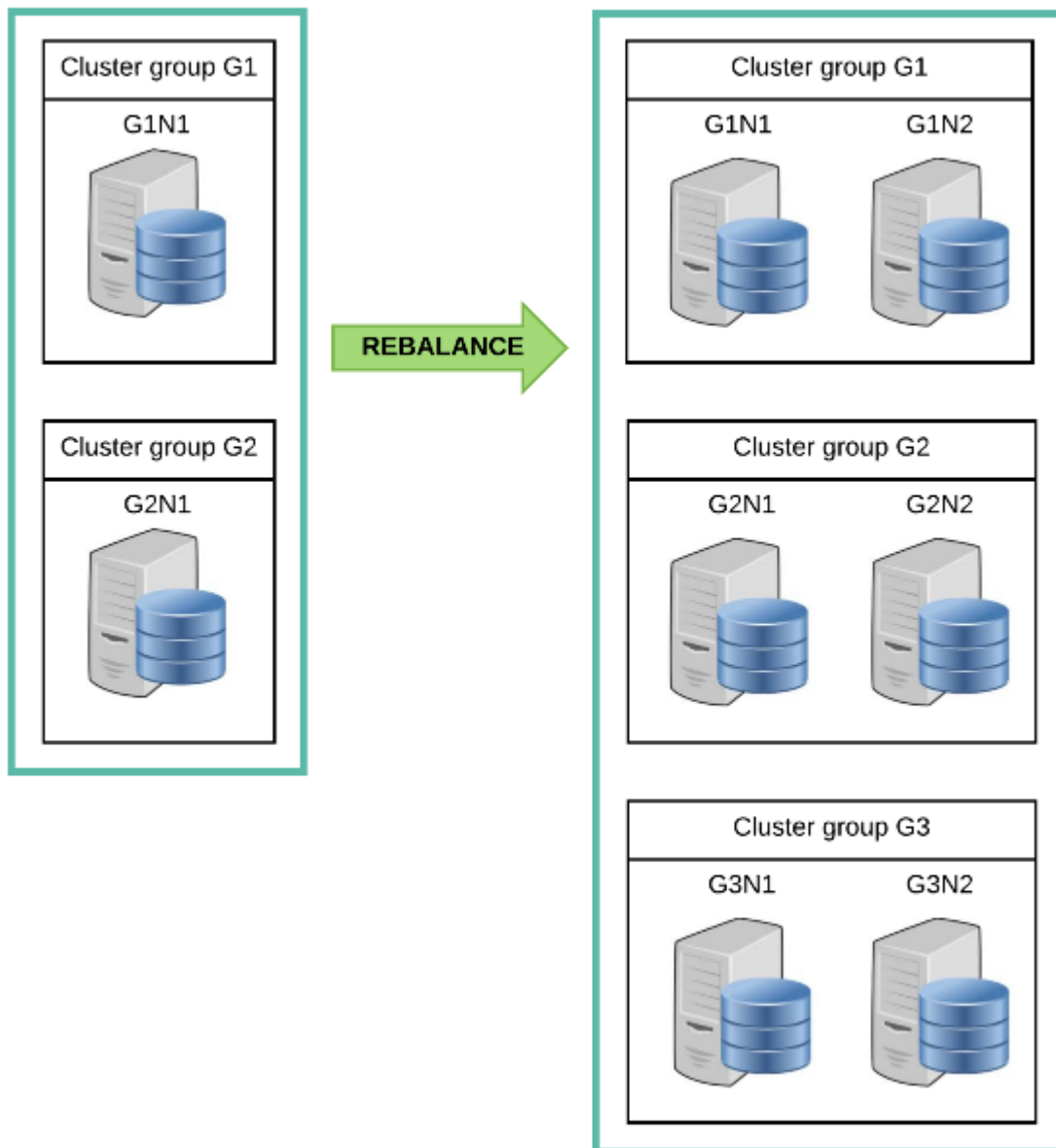

- When specifying the location to place the shard by using AT CLUSTER GROUP
  - The data is not rebalanced on the new cluster group.
  - The data can be rebalanced on the new cluster member which is added to the specified cluster group.

```
CREATE TABLE nation
(
  n_nationkey  INTEGER
, n_name      CHAR(25)
, n_regionkey INTEGER
, n_comment   VARCHAR(152)
```

```
)  
CLONED  
AT CLUSTER GROUP g1, g2;
```

Figure 14 Rebalancing the nation table defined by AT CLUSTER GROUP

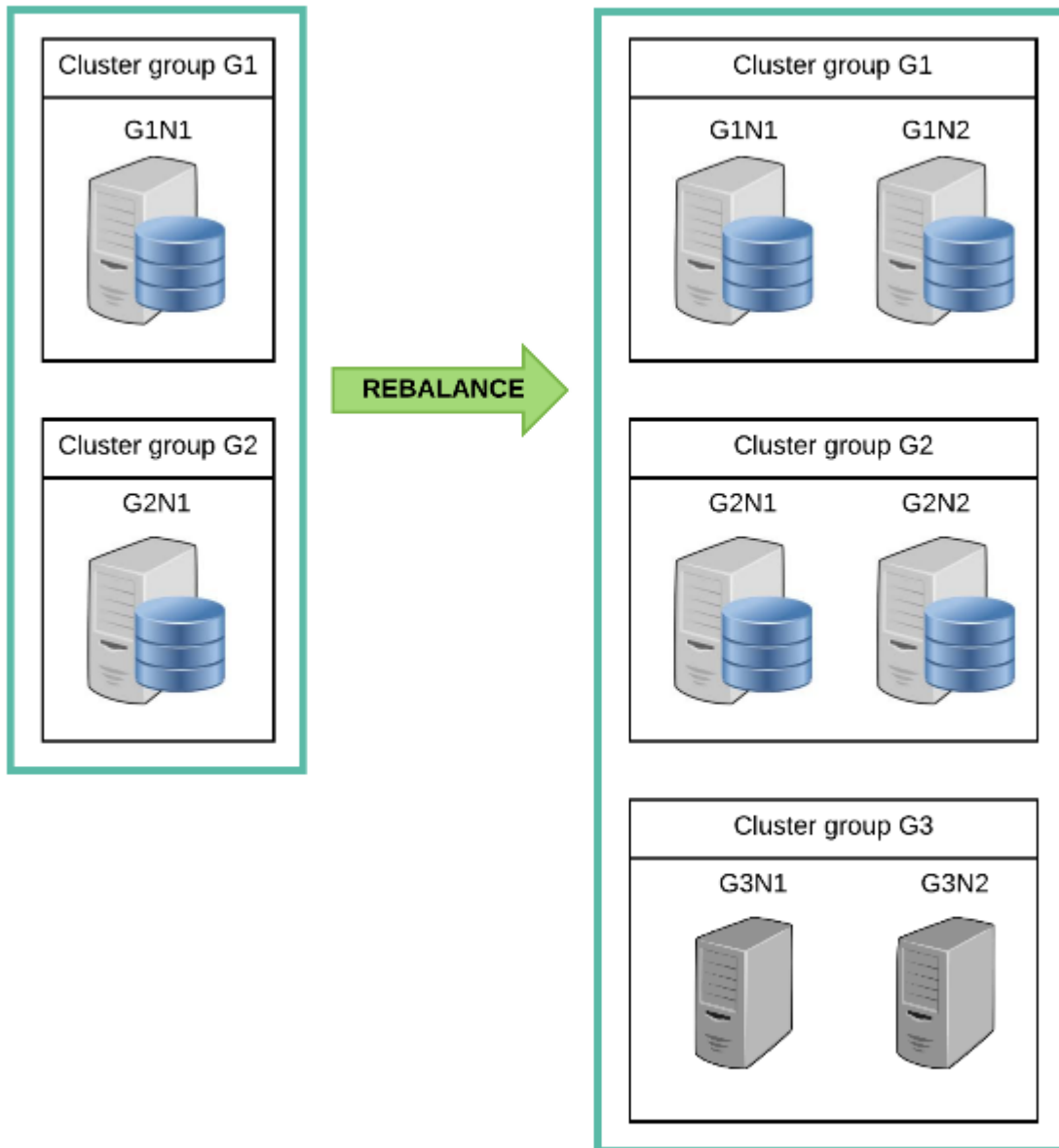

Information about the table placement can be retrieved through the following views.

- USER\_TAB\_PLACE
- ALL\_TAB\_PLACE

```

gSQL>
SELECT group_name, member_name
   FROM user_tab_place
  WHERE table_name = 'REGION';
GROUP_NAME MEMBER_NAME
-----
G1          G1N1
G1          G1N2
G2          G2N1
G2          G2N2
G3          G3N1
G3          G3N2
6 rows selected.

```

The sharded table is rebalanced in shard unit, and rebalancing shards due to the increase of groups is as follows.

```

CREATE TABLE orders
(
  o_orderkey    INTEGER
, o_custkey    INTEGER
, o_orderstatus CHAR(1)
, o_totalprice  NUMERIC(12,2)
, o_orderdate   DATE
, o_orderpriority CHAR(15)
, o_clerk       CHAR(15)
, o_shippriority INTEGER
, o_comment     VARCHAR(79)
)
SHARDING BY HASH( o_orderkey )
SHARD COUNT 24
AT CLUSTER WIDE
;

```

Figure 15 Rebalancing shards due to the increase of groups

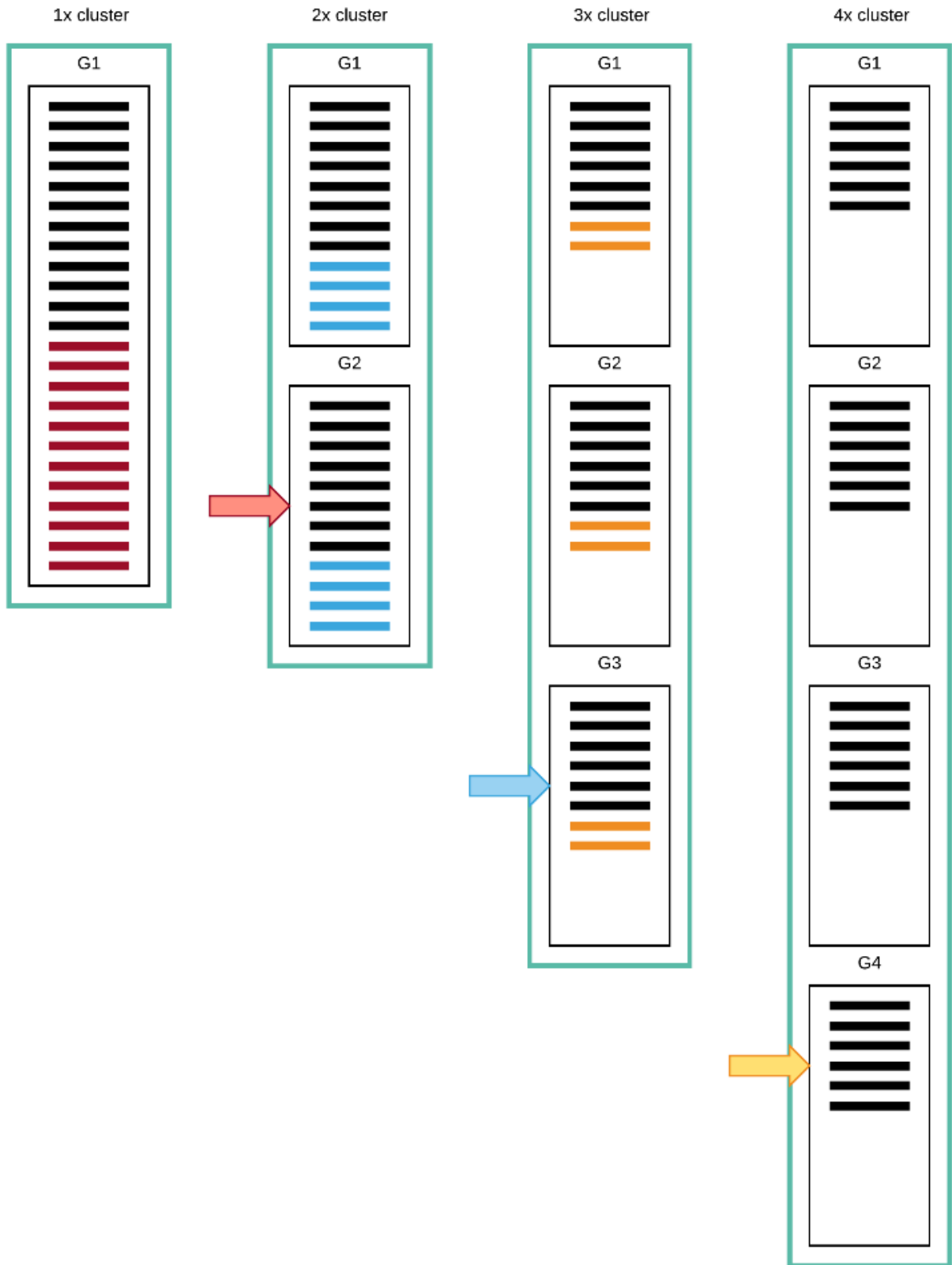

In the example above, the data of orders table is divided into 24 shards and placed. All shards are placed i

n a single group of 1x cluster which has only one group. 12 shards are placed in each group of 2x cluster which has two groups.

When expanding 2x cluster to 3x cluster, shards are transferred from an old group to the new group, but the number of shards in each group is same (8). When expanding 3x cluster to 4x cluster, then each G1, G2, G3 rebalances two shards to the newly created group G4.

In other words, the shard rebalancing minimizes the movement when shards are transferred from an old group to the new group, then data is equally rebalanced maintaining the same number of shards in each group.

Information about the shard placement of the sharded table can be retrieved through the following views.

- **USER\_TAB\_SHARDS**
- **ALL\_TAB\_SHARDS**

```
gSQL>
SELECT shard_name, group_name
   FROM user_tab_shards
  WHERE table_name = 'ORDERS';
SHARD_NAME  GROUP_NAME
-----
SHARD_000000 G1
SHARD_000001 G1
SHARD_000002 G1
SHARD_000003 G1
SHARD_000004 G1
SHARD_000005 G1
SHARD_000006 G1
SHARD_000007 G1
SHARD_000008 G3
SHARD_000009 G3
SHARD_000010 G3
SHARD_000011 G3
SHARD_000012 G2
SHARD_000013 G2
SHARD_000014 G2
SHARD_000015 G2
SHARD_000016 G2
SHARD_000017 G2
SHARD_000018 G2
SHARD_000019 G2
```

```
SHARD_000020 G3
SHARD_000021 G3
SHARD_000022 G3
SHARD_000023 G3
24 rows selected.
```

When tables which have the same <sharding strategy> are completely rebalanced as follows, then the shard placement result is same. Rows with the same shard key are guaranteed to be placed in the same shard and the same group even when the tables are different.

- Table t1
  - It is created in the 2x cluster.
  - CREATE TABLE t1 ( c1 INTEGER ) SHARDING BY (c1);
  - It is rebalanced in the 4x cluster.
  - ALTER TABLE t1 REBALANCE:
- Table t2
  - It is created in the 3x cluster.
  - CREATE TABLE t2 ( a1 INTEGER ) SHARDING BY (a1);
  - It is rebalanced in the 4x cluster.
  - ALTER TABLE t2 REBALANCE:
- Table t3
  - It is created in the 4x cluster.
  - CREATE TABLE t3 ( i1 INTEGER ) SHARDING BY (i1);

In other words, the following query can access only to a single cluster member and process it.

```
SELECT COUNT(*)
FROM t1, t2, t3
WHERE t1.c1 = t2.a1
AND t2.a1 = t3.i1
AND t1.c1 = 1;
```



## 14.6 Global Secondary Index

### Global Secondary Index Related Statements

For more information about creating, dropping, and altering a global secondary index, refer to the following.

- Creating a global secondary index: **ALTER TABLE name ADD GLOBAL SECONDARY INDEX**
- Dropping a global secondary index: **ALTER TABLE name DROP GLOBAL SECONDARY INDEX**
- Altering a global secondary index: **ALTER TABLE name ALTER GLOBAL SECONDARY INDEX**

Information related to a global secondary index can be retrieved through the following views.

**Table 14-6** Global secondary index related information

| Schema            | View                          | Description                                                     |
|-------------------|-------------------------------|-----------------------------------------------------------------|
| DICTIONARY_SCHEMA | ALL_CLUSTER_TABLES            | Existence of a global secondary index in user accessible table  |
|                   | ALL_GLOBAL_SECONDARY_INDEXES  | Object information of user accessible global secondary index    |
|                   | ALL_GSI_PLACE                 | Placement information of user accessible global secondary index |
|                   | USER_CLUSTER_TABLES           | Existence of a global secondary index in user owned table       |
|                   | USER_GLOBAL_SECONDARY_INDEXES | Object information of user owned global secondary index         |
|                   | USER_GSI_PLACE                | Placement information of user owned global secondary index      |

### Concepts of Global Secondary Index

A global secondary index is a B-Tree index which configures the GRID (global row identifier) value as a key in each cluster member of the cluster environment.

Tables in the cluster environment are duplicated to all members in a group and the same records are applied and retrieved when performing DML or select. GRID is a unique value identifying the same records in cluster members, and it is allocated when the record is inserted for the first time, and it is spread over all members in a group, then stored together with the record.

When creating a table in a cluster environment, a global secondary index may or may not be created, and

it can be separately created or deleted after the table is created. A table may not have a global secondary index, or it may have maximum one global secondary index.

**Figure 16** Structure of a global secondary index

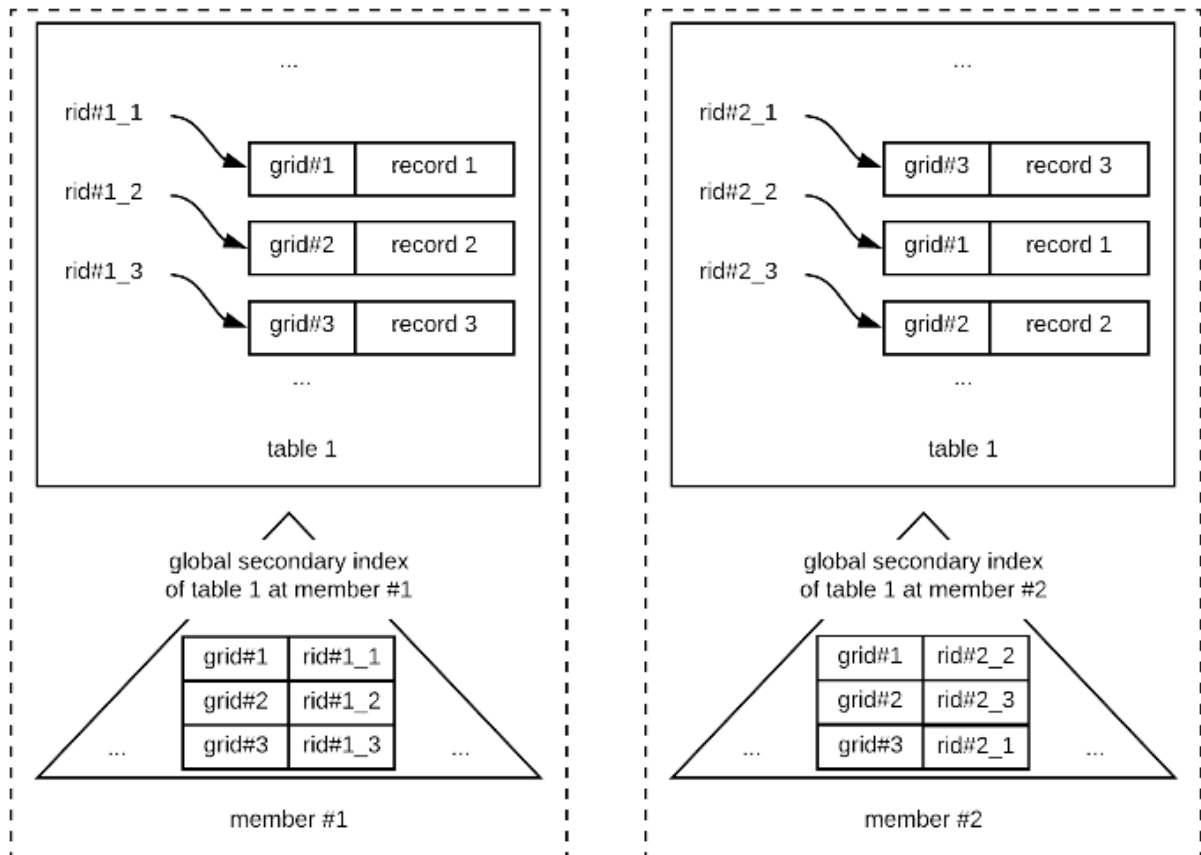

A global secondary index is required to perform a non-deterministic query for a table. If the table does not have a global secondary index, then the non-deterministic query fails as follows.

```
gSQL> DELETE FROM T1 LIMIT 1;
```

```
ERR-42000(16423): does not support non-deterministic DML in the cluster system : global  
secondary index expected
```

Refer to the dictionary such as `ALL_GSI_PLACE`, `DBA_GSI_PLACE`, and `USER_GSI_PLACE` to check if a table has a global secondary index.

**15.**

---

## **SQL Tuning**

# 15.1 SQL Tuning

## Overview

SQL tuning is a process of analyzing and modifying a query statement to improve the performance.

This process helps a query statement reach to the desired performance level by decreasing the response time of a query statement or by increasing the throughput.

The knowledge about SQL processing and an optimizer is required to perform SQL tuning, so this chapter describes them.

## SQL Processing

The following figure describes the SQL processing.

Figure 1 SQL processing

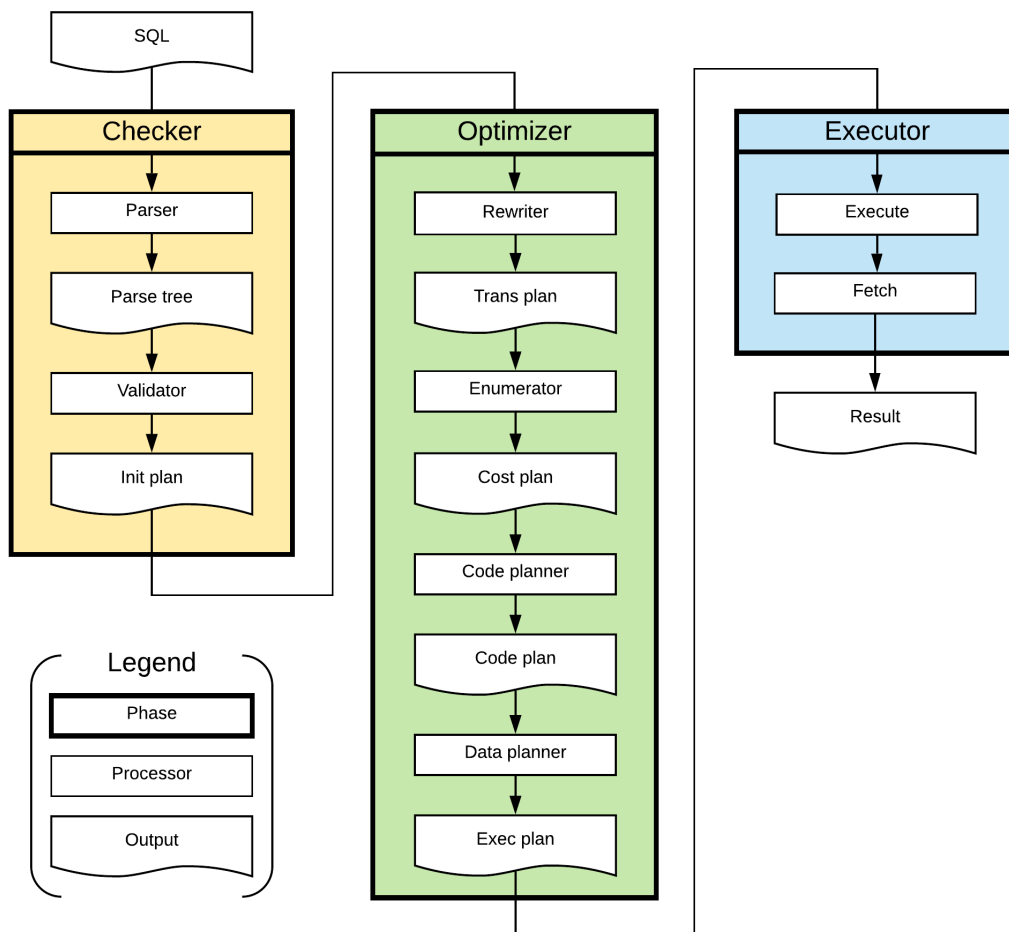

The user query returns the result through a parser, a validator, a rewriter, an enumerator, a code planner, a data planner, an executor phases. The following paragraphs describes each phase.

## Parser

A parser checks a grammatical error of SQL statement input by a user.

```
gSQL> SELECT * FORM customer;
ERR-42000(40000): syntax error
SELECT * FORM customer
.....^ ^
Error at line 1
```

If the SQL statement does not have a grammatical error, then it creates a parse tree. Then it becomes an input argument of a validator in the next phase.

## Validator

A validator checks semantic error of a parse tree which was input.

For example, it checks whether an object such as a table or a column specified in a query exists, and if a user has a privilege to refer to those objects.

```
gSQL> SELECT * FROM customer;
ERR-42000(16040): table or view does not exist :
SELECT * FROM customer
          *
ERROR at line 1:
```

If a parse tree does not have a semantic error, then an init plan is created based on it.

## Rewriter

A rewriter converts a SQL statement into a high performance SQL with the same meaning.

It analyzes an init plan, creates a trans plan, converts it to a trans plan in a form whose high performance is expected. The converted trans plan becomes an input argument of enumerator phase.

For more information about converting SQL statement, refer to **Rewriter**.

## Enumerator

An enumerator calculates the cost of multiple plans based on the statistics information, and creates the best cost plan.

For more information about various optimization methods such as an access path to a table a join ordering and a join method determination, refer to **Enumerator**.

## Code Planner

A code planner creates a code plan.

A code plan creates the plan finally selected by an enumerator into an execution plan form. An execution plan consists of tree structure nodes, and it includes the following information.

- How to access each table
- The sequence to refer to tables
- How perform the operation joining tables
- The information about the data filter
- The information about grouping and aggregating the data
- The information about sorting the data

## Plan Cache

Code plans created by a code planner are registered in a plan cache. The registered plans are classified according to whether plan cache parameters values match.

**Table 15-1** Plan cache parameters

| Parameter         | Description                                                               |
|-------------------|---------------------------------------------------------------------------|
| Query text        | Case-sensitive query text                                                 |
| User information  | User ID                                                                   |
| Cursor property   | Cursor property of a query requiring fetch                                |
| Bind parameter    | The number of bind parameters and IN/ OUT property of each bind parameter |
| Enable atomic     | Whether to use an atomic insertion                                        |
| Enable hint error | Whether a validation error occurs in a hint                               |

When a user query is input, then it checks whether the plan with the same plan cache parameters values exist in a plan cache. If exists, it omits parser-validator-rewriter-enumerator-code planner process, and used the plan registered in the plan cache.

When using the plan registered in the plan cache in this way, then the cost for parser-validator-rewriter-enumerator-code planner process decreases, so it improves the performance.

The following is an example of queries whose query texts values are different. Though they are same que

ries, but their capitalization is different, so the queries below are not recognized as a same plan.

```
"SELECT * FROM customer"
"select * from customer"
"Select * From customer"
"SELECT * FROM customer"
```



If a schema object (table, index, view, sequence) referenced by a plan is not committed, then the plan is not registered.

## Data Planner

A data planner creates a data plan. A data plan has a space to store the intermediate result and a temporary space to store the expression result while performing code plans.

## Executor

An executor returns the actual executed result of performing a code plan and a data plan.

Figure 2 Executor

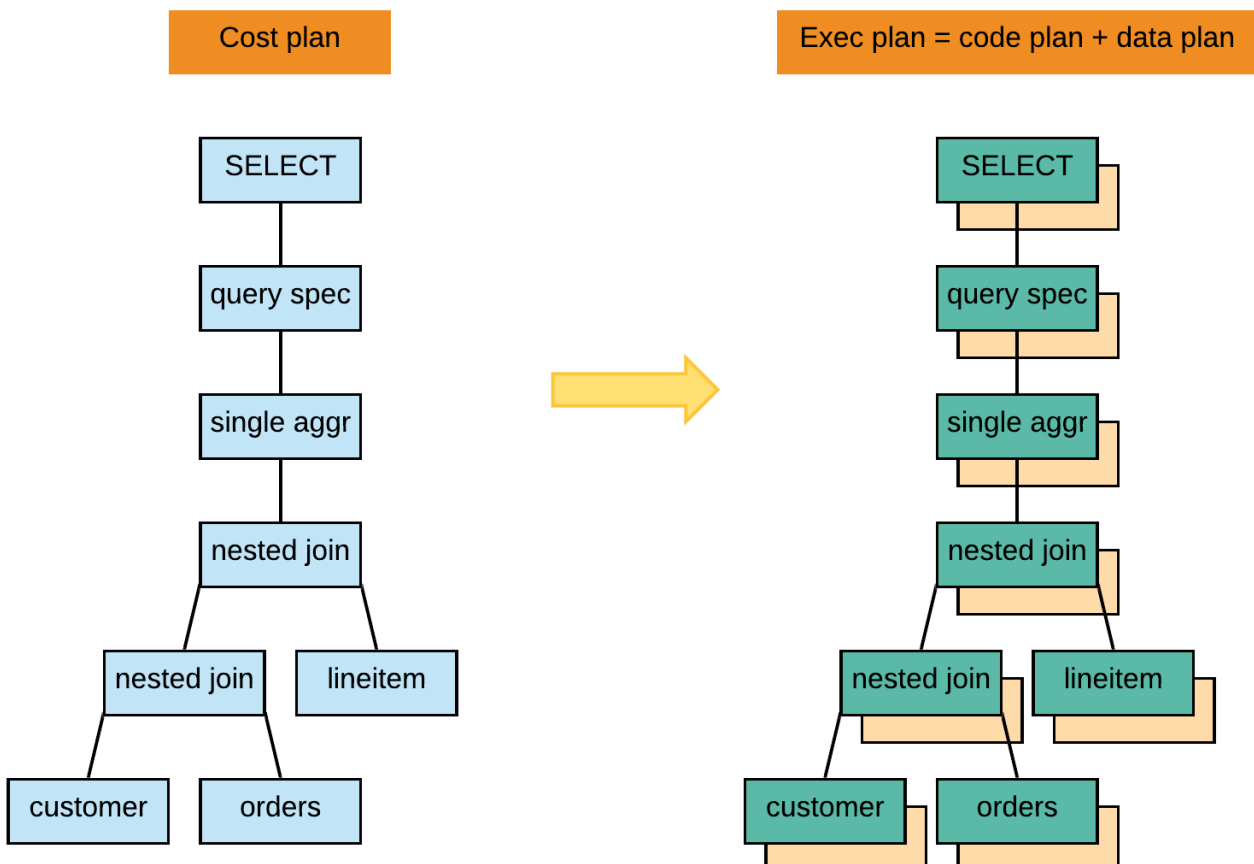

## Execution Plan

The execution plan consists of a code plan and a data plan. It is a tree form whose top node is INSERT, DELETE, UPDATE, SELECT statement.

The execution is a basic analysis tool of SQL tuning. The execution plan describes how the query is converted by a rewriter and which access path, join order, join method is selected by an enumerator.

The followings are a syntax and an example to output the execution plan.

### Syntax

The following is a syntax to output the execution plan.

```
<explain plan> ::=
    \explain plan [ on | only ] <sql statement>
<sql statement> ::=
    <query expression>
    | <select for update statement>
    | <select statement: single row>
    | <insert statement>
    | <update statement: searched>
    | <delete statement: searched>
```

### Invocation and Access Rules

The privilege to access <sql statement> statement is required to perform <explain plan> statement.

### Syntax Rules and Parameters

```
\EXPLAIN PLAN ON
\EXPLAIN PLAN
```

When specifying as above, it performs the query then outputs the execution plan.

```
\EXPLAIN PLAN ONLY
```

When specifying as above, it does not perform the query but only outputs the execution plan.

### Example

When executing as follows, it performs SQL statement, and outputs the query result and the execution plan together.

The following example is executed in a cluster system which consists of G1(G1N1, G1N2), G2(G2N1, G2



N2) and G3(G3N1, G3N2). The customer is a cloned table and orders is a sharded table whose data is divided by do\_orderkey.

Figure 3 Read plan

```

\EXPLAIN PLAN
SELECT  c_name,
        o_orderdate,
        o_orderstatus
FROM    customer,
        orders
WHERE   c_custkey = o_custkey
        AND o_orderdate >= date '1995-03-15'
        AND o_orderdate < date '1995-03-15' + interval '1' month;
...
19343 rows selected.
>>> start print plan
< Execution Plan >

```

| Code plan                                                    | Data plan          |
|--------------------------------------------------------------|--------------------|
| 0   SELECT STATEMENT                                         | 19343              |
| 1     QUERY BLOCK ("SQB_IDX_2")                              | 19343              |
| 2       PLAN BASED CLUSTER                                   | LOCAL/REMOTE 19343 |
| 3         NESTED JOIN (INNER JOIN)                           | 6389               |
| 4           TABLE ACCESS ("ORDERS")                          | 6389               |
| 5             INDEX ACCESS ("CUSTOMER", "CUSTOMER_PK_INDEX") | ( 6389) 6389       |

```

1 - TARGET : CUSTOMER.C_NAME, ORDERS.O_ORDERDATE, ORDERS.O_ORDERSTATUS
2 - SQL : SELECT /*+ KEEP_JOINED_TABLE
           USE_NL_IN( _A1 )
           FULL( _A2 )
           INDEX( _A1, "PUBLIC"."CUSTOMER_PK_INDEX" )
        */
        "_A1"."C_NAME", "_A2"."O_ORDERDATE", "_A2"."O_ORDERSTATUS"
FROM ( "PUBLIC"."ORDERS"@LOCAL AS "_A2"
      INNER JOIN
      "PUBLIC"."CUSTOMER"@LOCAL AS "_A1" ON true
      ) ALIAS "_A3"
WHERE "_A2"."O_ORDERDATE" < :_V0
      AND "_A2"."O_ORDERDATE" >= :_V1
      AND "_A1"."C_CUSTKEY" = "_A2"."O_CUSTKEY"
3 - TARGET DOMAIN : G1(G1N1,G1N2) 6389 rows, G2(G2N1,G2N2) 6462 rows, G3(G3N1,G3N2) 6492 rows
4 - JOINED COLUMN : CUSTOMER.C_NAME, ORDERS.O_ORDERDATE, ORDERS.O_ORDERSTATUS
4 - HASH SHARD ( # 3 )
READ COLUMN : ORDERS.O_CUSTKEY, ORDERS.O_ORDERSTATUS, ORDERS.O_ORDERDATE
PHYSICAL FILTER : ORDERS.O_ORDERDATE < DATE'1995-03-15' + CAST( '1' AS INTERVAL(MONTH) )
                  AND ORDERS.O_ORDERDATE >= DATE'1995-03-15'
5 - CLONED
READ INDEX COLUMN : CUSTOMER.C_CUSTKEY
READ TABLE COLUMN : CUSTOMER.C_NAME
MIN RANGE : CUSTOMER.C_CUSTKEY = {ORDERS.O_CUSTKEY}
MAX RANGE : CUSTOMER.C_CUSTKEY = {ORDERS.O_CUSTKEY}
FETCH ONE ROW
<<< end print plan

```

The execution plan above is represented as the following tree. The execution starts from the bottom node.

Figure 4 Read plan tree

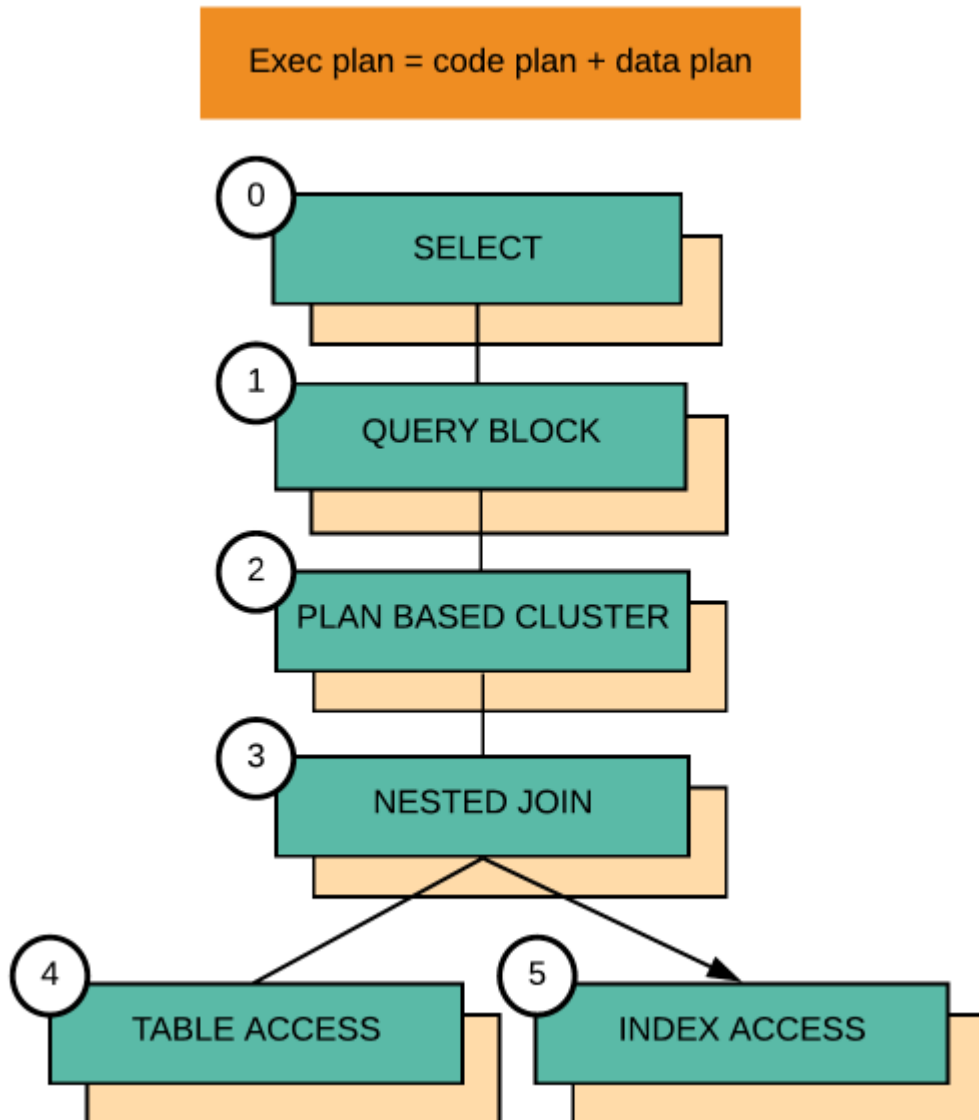

The execution tree above is performed as follows.

First, PLAN BASED CLUSTER(IDX 2) transfers the following SQL to G1, G2 and G3.

```

SELECT /*+ KEEP_JOINED_TABLE
        USE_NL_IN( _A1 )
        FULL( _A2 )
        INDEX( _A1, "PUBLIC"."CUSTOMER_PK_INDEX" )
*/
_A1"."C_NAME", _A2"."O_ORDERDATE", _A2"."O_ORDERSTATUS"
FROM ( "PUBLIC"."ORDERS"@LOCAL AS "_A2"
      INNER JOIN
      "PUBLIC"."CUSTOMER"@LOCAL AS "_A1" ON true
      ) ALIAS "_A3"
  
```

```
WHERE "_A2"."O_ORDERDATE" < :_V0
AND "_A2"."O_ORDERDATE" >= :_V1
AND "_A1"."C_CUSTKEY" = "_A2"."O_CUSTKEY"
```

TABLE ACCESS(IDX:4) and INDEX ACCESS(IDX:5) read data from customer table and orders table and perform NESTED JOIN(IDX 3) in G1, G2, G3.

PLAN BASED CLUSTER brings all NESTED JOIN(IDX 3) results of G1, G2, G3 to local.

Then, it returns the result.

## Execution Plan Information

The information about each column in the execution plan table is as follows.

- **IDX**
  - It is an identifier given to each plan node.
- **NODE DESCRIPTION**
  - It is the name of a plan node.
  - The contents in brackets are additional information which distinguishes plan nodes.
  - The indented plan node means the subordinate plan node.
    - The execution starts from the bottom plan node, and the result is transferred to the superordinate node.
- **ROWS**
  - It is the number of result records according to the plan node execution.

Each plan node contains the following optimization information.

- **Access Paths** to each table
- The sequence to process **Join** and join method
- The information about **Group By** processing
- The information about **Distinct** processing
- The information about **Single Row Aggregation** processing
- The information about **Order By** processing
- The information about **Cluster Puller** processing
- The information about **Cluster Pusher** processing

## 15.2 Rewriter

This chapter describes various query transformation methods processed by a rewriter.

### Filter Push Down

It pushes down the filter as down as possible so that it reduces the intermediate result to be processed.

The following is an example of filter push down.

Figure 5 Filter push down

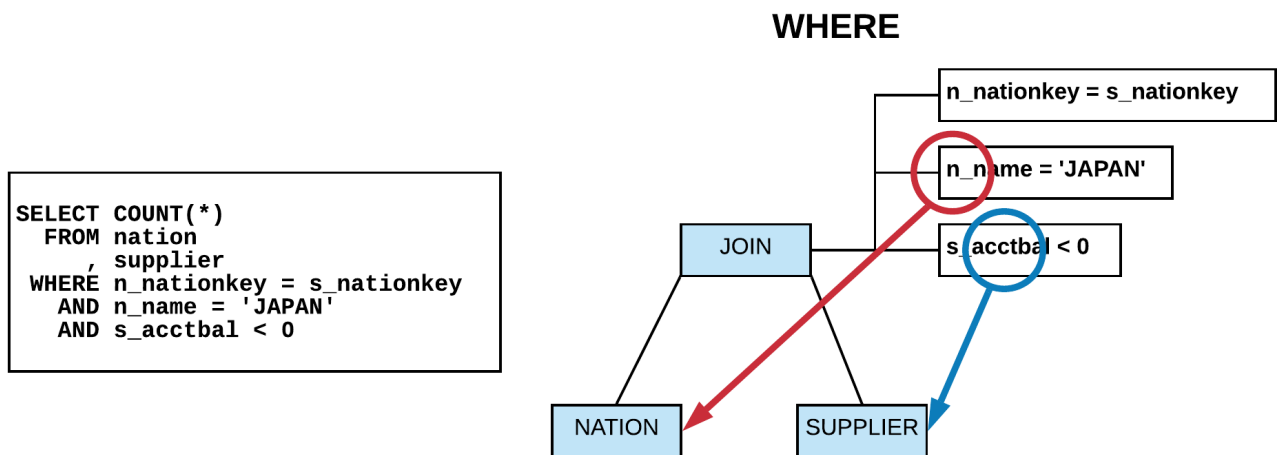

It filters rows satisfying `n_name = JAPAN` condition in `NATION`, and filters rows satisfying `s_acctbal < 0` condition in `SUPPLIER` before performing join. In this case the number of join target rows decreases so it improves the performance.

The following is an example of performing filter push down into the view.

Figure 6 Filter push down into view

```
CREATE VIEW revenue (supplier_no, total_revenue) AS
  SELECT l_suppkey,
         ROUND( sum(l_extendedprice * (1 - l_discount)), 2)
  FROM lineitem
  WHERE l_shipdate >= date '1996-01-01'
        AND l_shipdate < date '1996-01-01' + interval '3' month
  GROUP BY l_suppkey;
```

```
SELECT total_revenue
FROM revenue
WHERE supplier_no = 100
```

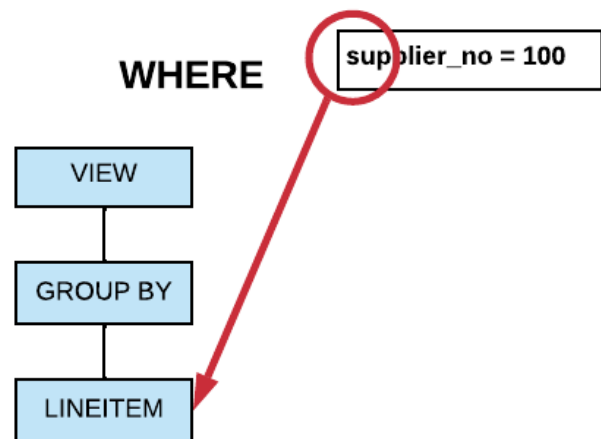

When pushing it down to lineitem TABLE ACCESS node after converting `supplier_no = 100` to `l_suppkey = 100`, then target rows of GROUP BY decreases so it improves the performance.

## DISTINCT Elimination

It eliminates the unnecessary DISTINCT.

DISTINCT is eliminated in the following cases.

- The query result of a single-row aggregation is one, so duplicate results do not occur even without DISTINCT.
- If *group by* exists and all key columns of *group by* exist in a select list, then the result is unique so duplicate results do not occur even without DISTINCT.
- If all key columns in a primary key exist in a select list, then the result is unique so duplicate results do not occur even without DISTINCT.

The following is an example of eliminating DISTINCT.

Figure 7 DISTINCT elimination

```

\explain plan
SELECT DISTINCT
  r_name
FROM region
;

R_NAME
-----
EUROPE
AMERICA
ASIA
MIDDLE EAST
AFRICA

5 rows selected.

>>> start print plan

< Execution Plan >
=====
|  IDX  |  NODE DESCRIPTION  |
=====
0	SELECT STATEMENT
1	QUERY BLOCK ("SQB_IDX_2")
2	GROUP HASH INSTANT
3	TABLE ACCESS ("REGION")
=====	
1	- TARGET : REGION.R_NAME
2	- GROUP KEY : REGION.R_NAME
	- READ KEY COLUMN : REGION.R_NAME
3	- CLONED
	- READ COLUMN : REGION.R_NAME
=====
<<< end print plan

```

```

\explain plan
SELECT DISTINCT
  r_regionkey
FROM region
;

R_REGIONKEY
-----
0
1
2
3
4

5 rows selected.

>>> start print plan

< Execution Plan >
=====
|  IDX  |  NODE DESCRIPTION  |
=====
0	SELECT STATEMENT
1	QUERY BLOCK ("SQB_IDX_2")
2	INDEX ACCESS ("REGION", "REGION_PK_INDEX")
=====	
1	- TARGET : REGION.R_REGIONKEY
2	- CLONED
	- READ INDEX COLUMN : REGION.R_REGIONKEY
=====
<<< end print plan

```

The left execution plan has GROUP HASH INSTANT node to process DISTINCT, but the right execution plan does not have GROUP HASH INSTANT node to process DISTINCT.

r\_regionkey is a primary key, so it is guaranteed that the result is distinct even when DISTINCT is eliminated. Therefore, the unnecessary DISTINCT is eliminated.

## ORDER BY Elimination

It eliminates unnecessary ORDER BY.

ORDER BY is not required in the following cases.

- When only a view exists in *from* clause, and *group by* clause, *distinct* clause or *order by* clause exists, then *order by* exists in a query block within a view is not necessary. It is because the sequence ordered by *group by*, *distinct*, *order by* disappears even though it was ordered.
- *order by* exists in a query block within a subquery is not necessary. It is because the subquery result is used only when determining whether to return the row of an outer query.

The following is an example of eliminating ORDER BY.

Figure 8 ORDERBY elimination

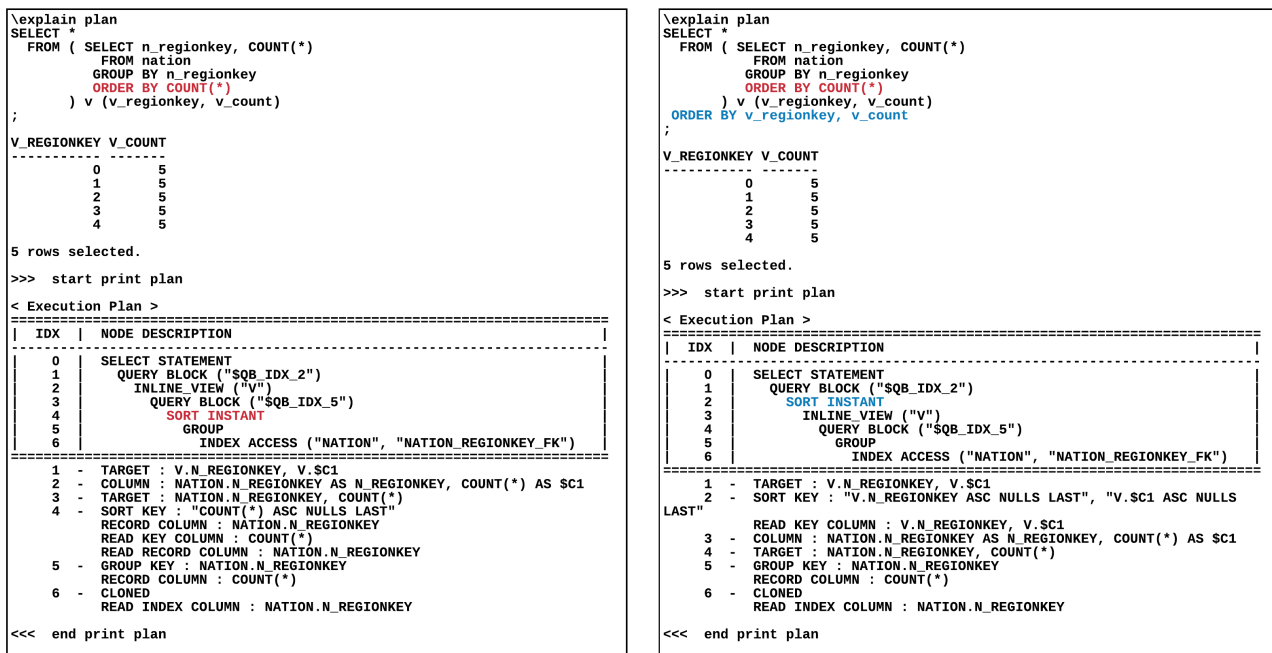

The left and right views are same in the figure above, but the right SQL has *order by* in a superordinate query of the view, so the *order by* within the view is eliminated.

## Simple View Merging

It merges a simple view which does not include *group by*, *distinct*, *aggregation* into a superordinate query block.

Applying a simple view merging enables an optimizer to select various access path, join ordering, join method, so it can acquire the better execution plan.

A simple view merging can not be applied to the following cases.

- When a query block within the view includes the followings
  - Set operator
  - LIMIT, OFFSET
  - DISTINCT
  - GROUP BY
  - Single row aggregation
  - Full outer join
  - Natural join
  - ROWNUM
  - When a subquery expression exists in SELECT list
- When a view participates in the following query.

- A view participate in a full outer join.
- A view participate in a left outer join, and two or more tables exist within a view.

The following is an example of merging a simple view.

```
CREATE VIEW v_nation
(
  v_nationkey,
  v_nation_name,
  v_region_name
)
AS
SELECT n_nationkey,
       n_name,
       r_name
FROM nation, region
WHERE n_regionkey = r_regionkey;
```

```
\EXPLAIN PLAN
SELECT v_nation_name, COUNT(*)
FROM customer, v_nation
WHERE c_nationkey = v_nationkey
AND v_region_name = 'ASIA'
GROUP BY v_nation_name;
V_NATION_NAME          COUNT(*)
-----
```

```
CHINA                  6024
INDIA                  6042
INDONESIA               6161
JAPAN                  5948
VIETNAM               6008
```

5 rows selected.

```
>>> start print plan
```

```
< Execution Plan >
```

```
=====
IDX	NODE DESCRIPTION
0	SELECT STATEMENT
1	QUERY BLOCK ("QB_IDX_2")
2	GROUP HASH INSTANT
3	NESTED JOIN (INNER JOIN)
```



```

4	NESTED JOIN (INNER JOIN)
5	TABLE ACCESS ("REGION")
6	INDEX ACCESS ("NATION", "NATION_REGIONKEY_FK")
7	INDEX ACCESS ("CUSTOMER", "CUSTOMER_NATIONKEY_FK")
=====
1 - TARGET : NATION.N_NAME, COUNT(*)
2 - GROUP KEY : NATION.N_NAME
   RECORD COLUMN : COUNT(*)
   READ KEY COLUMN : NATION.N_NAME
   READ RECORD COLUMN : COUNT(*)
3 - JOINED COLUMN : NATION.N_NAME
4 - JOINED COLUMN : NATION.N_NATIONKEY, NATION.N_NAME
5 - CLONED
   READ COLUMN : REGION.R_REGIONKEY, REGION.R_NAME
   PHYSICAL FILTER : REGION.R_NAME = 'ASIA'
6 - CLONED
   READ INDEX COLUMN : NATION.N_REGIONKEY
   READ TABLE COLUMN : NATION.N_NATIONKEY, NATION.N_NAME
   MIN RANGE : NATION.N_REGIONKEY = {REGION.R_REGIONKEY}
   MAX RANGE : NATION.N_REGIONKEY = {REGION.R_REGIONKEY}
7 - CLONED
   READ INDEX COLUMN : CUSTOMER.C_NATIONKEY
   MIN RANGE : CUSTOMER.C_NATIONKEY = {NATION.N_NATIONKEY}
   MAX RANGE : CUSTOMER.C_NATIONKEY = {NATION.N_NATIONKEY}
<<< end print plan

```

A view does not exist in the execution plan above. The view is merged to an outer query, then it is performed as a converted query form as follows.

Figure 9 Simple view merging

|                                                                                                                                                                         |                                                                                     |                                                                                                                                                                                         |
|-------------------------------------------------------------------------------------------------------------------------------------------------------------------------|-------------------------------------------------------------------------------------|-----------------------------------------------------------------------------------------------------------------------------------------------------------------------------------------|
| <pre> \explain plan SELECT v_nation_name , COUNT(*) FROM customer , v_nation WHERE c_nationkey = v_nationkey AND v_region_name = 'ASIA' GROUP BY v_nation_name ; </pre> |  | <pre> \explain plan SELECT n_name , COUNT(*) FROM customer , nation , region WHERE c_nationkey = n_nationkey AND r_name = 'ASIA' AND n_regionkey = r_regionkey GROUP BY n_name ; </pre> |
|-------------------------------------------------------------------------------------------------------------------------------------------------------------------------|-------------------------------------------------------------------------------------|-----------------------------------------------------------------------------------------------------------------------------------------------------------------------------------------|

## Outer Join Table Elimination

It eliminates an unnecessary outer join table.

Neither an outer join nor access to the right table is required in the following cases.

- It is a left outer join, and
  - a predicate in a form of *left\_table.col = right\_table.col* exists in ON clause.
  - a unique index for *right\_table.col* of ON clause exists.
  - a column in a right table is not used in any other clauses except for ON clause condition.

The following is an example of eliminating an outer join table.

The access to nation table exists only in ON clause, and *n\_nationkey* is a primary key column in the following example, so it is unique and even null data does not exist. Therefore, eliminating nation table does not affect the result.

```
\EXPLAIN PLAN
SELECT COUNT(*)
  FROM supplier
     LEFT OUTER JOIN
     nation
     ON s_nationkey = n_nationkey
 WHERE s_acctbal < 0
;
COUNT(*)
-----
      886
1 row selected.
>>> start print plan
< Execution Plan >
=====
|  IDX  |  NODE DESCRIPTION                                |  ROWS  |
-----|-----|-----|
|    0  |  SELECT STATEMENT                                |        |
|    1  |    QUERY BLOCK ("SQB_IDX_2")                     |        |
|    2  |      TABLE ACCESS ("SUPPLIER")                   |        |
=====
1 - TARGET : COUNT(*)
2 - CLONED
   READ COLUMN : SUPPLIER.S_ACCTBAL
   AGGREGATION : COUNT(*)
```

```

                PHYSICAL FILTER : SUPPLIER.S_ACCTBAL < 0
<<< end print plan

```

All accesses to OUTER JOIN and right table are eliminated in the execution plan above.

## Outer Join Operation Elimination

It eliminates an unnecessary outer join operation.

- For a left outer join,
  - If a conditional clause corresponding to the right table exists in where clause, and the conditional clause is not IS NULL,
    - It can be changed to an inner join
- For a full outer join,
  - If a conditional clause corresponding to the right table exists in where clause, and the conditional clause is not IS NULL,
    - It can be changed to a right outer join
  - If a conditional clause corresponding to the left table exists in where clause, and the conditional clause is not IS NULL,
    - It can be changed to a left outer join.
  - If a conditional clause corresponding to both left and right tables exists in where clause, and the conditional clause is not IS NULL,
    - It can be changed to an inner join

The following is an example of eliminating an outer join operation.

```

\EXPLAIN PLAN
SELECT MAX(COUNT(*))
  FROM customer
     LEFT OUTER JOIN
     orders
     ON  c_custkey = o_custkey
     AND o_comment LIKE '%special%requests%'
     WHERE o_orderpriority = '1-URGENT'
GROUP BY c_custkey;
MAX(COUNT(*))
-----
                3
1 row selected.
>>> start print plan
< Execution Plan >

```

```

=====
|  IDX  |  NODE DESCRIPTION  |
=====
0	SELECT STATEMENT
1	QUERY BLOCK ("QB_IDX_2")
2	AGGREGATION BY HASH
3	GROUP
4	HASH JOIN (INNER JOIN)
5	INDEX ACCESS ("CUSTOMER", "CUSTOMER_PK_INDEX")
6	HASH JOIN INSTANT
7	TABLE ACCESS ("ORDERS")
=====

1 - TARGET : MAX( COUNT(*) )
2 - AGGREGATION : MAX( COUNT(*) )
3 - GROUP KEY : CUSTOMER.C_CUSTKEY
   RECORD COLUMN : COUNT(*)
4 - JOINED COLUMN : CUSTOMER.C_CUSTKEY
5 - READ INDEX COLUMN : CUSTOMER.C_CUSTKEY
6 - HASH KEY : ORDERS.O_CUSTKEY
   READ KEY COLUMN : ORDERS.O_CUSTKEY
   HASH FILTER : ORDERS.O_CUSTKEY = CUSTOMER.C_CUSTKEY
7 - READ COLUMN : ORDERS.O_CUSTKEY, ORDERS.O_ORDERPRIORITY,
   ORDERS.O_COMMENT
   PHYSICAL FILTER : ORDERS.O_ORDERPRIORITY = '1-URGENT'
   LOGICAL FILTER : ORDERS.O_COMMENT LIKE '%special%requests%'

<<< end print plan

```

*o\_orderpriority = '1-URGENT'* condition exists in WHERE clause in the example above. Therefore, rows all of whose data is NULL can not exist as a result of the right table due to this condition.

Therefore, the results are same even when converting a left outer join to an inner join.

## EXISTS/NOT EXIST Operation Target Optimization

It decreases unnecessary expressions from SELECT list of a subquery which exists in EXISTS or NOT EXISTS, so that it improves the query processing performance.

EXISTS or NOT EXISTS operation is an operator which determines whether the result row of a subquery exists, so neither the number of expressions in SELECT list of a subquery nor does the processing result affect the operation result. Therefore, it changes SELECT list of the subquery to TRUE (BOOLEAN constant).

The following is an example of optimizing EXISTS operation target.

```

\EXPLAIN PLAN
SELECT o_orderpriority,
       count(*) as order_count
FROM orders
WHERE o_orderdate = date '1993-07-01'
AND EXISTS (
    SELECT /*+ NO_UNNEST */
        *
    FROM lineitem
    WHERE l_orderkey = o_orderkey
        AND l_commitdate < l_receiptdate
)
GROUP BY o_orderpriority
ORDER BY o_orderpriority;
O_ORDERPRIORITY ORDER_COUNT
-----
1-URGENT          113
2-HIGH            136
3-MEDIUM         112
4-NOT SPECIFIED  103
5-LOW             97
5 rows selected.
>>> start print plan
< Execution Plan >
=====
|IDX|  NODE DESCRIPTION                                     |
-----
0	SELECT STATEMENT
1	QUERY BLOCK ("$_QB_IDX_2")
2	SORT INSTANT
3	GROUP HASH INSTANT
4	TABLE ACCESS ("ORDERS")
5	SUB QUERY LIST
6	INLINE_VIEW ("$_V6")
7	QUERY BLOCK ("$_QB_IDX_6")
8	INDEX ACCESS ("LINEITEM", "LINEITEM_ORDERKEY_FK")
=====
1 - TARGET : ORDERS.O_ORDERPRIORITY, COUNT(*) AS ORDER_COUNT
2 - SORT KEY : "ORDERS.O_ORDERPRIORITY ASC NULLS LAST"

```

```

RECORD COLUMN : COUNT(*)
READ KEY COLUMN : ORDERS.O_ORDERPRIORITY
READ RECORD COLUMN : COUNT(*)
3 - GROUP KEY : ORDERS.O_ORDERPRIORITY
RECORD COLUMN : COUNT(*)
READ KEY COLUMN : ORDERS.O_ORDERPRIORITY
READ RECORD COLUMN : COUNT(*)
4 - READ COLUMN : ORDERS.O_ORDERKEY, ORDERS.O_ORDERDATE,
                ORDERS.O_ORDERPRIORITY
    PHYSICAL FILTER : ORDERS.O_ORDERDATE = DATE'1993-07-01'
    POST FILTER : EXISTS( ( $V6.DUMMY_COL ) )
6 - COLUMN : $V6.DUMMY_COL AS DUMMY_COL
7 - TARGET : NOTHING
8 - READ INDEX COLUMN : LINEITEM.L_ORDERKEY
READ TABLE COLUMN : LINEITEM.L_COMMITDATE, LINEITEM.L_RECEIPTDATE
    MIN RANGE : LINEITEM.L_ORDERKEY = {ORDERS.O_ORDERKEY}
    MAX RANGE : LINEITEM.L_ORDERKEY = {ORDERS.O_ORDERKEY}
    PHYSICAL TABLE FILTER : LINEITEM.L_RECEIPTDATE > LINEITEM.L_COMMITDATE
<<< end print plan

```

lineitem is a table with 16 columns in the example above. It is specified to read all columns in lineitem by using \* in SELECT list within EXISTS subquery of a user query. However, it fetches only the information about whether the row satisfying the condition exists, but target column value does not fetch anything at the time of execution.

## Quantifier Elimination

It alters SQL as follows to eliminate ANY quantifier.

Figure 10 Quantifier elimination

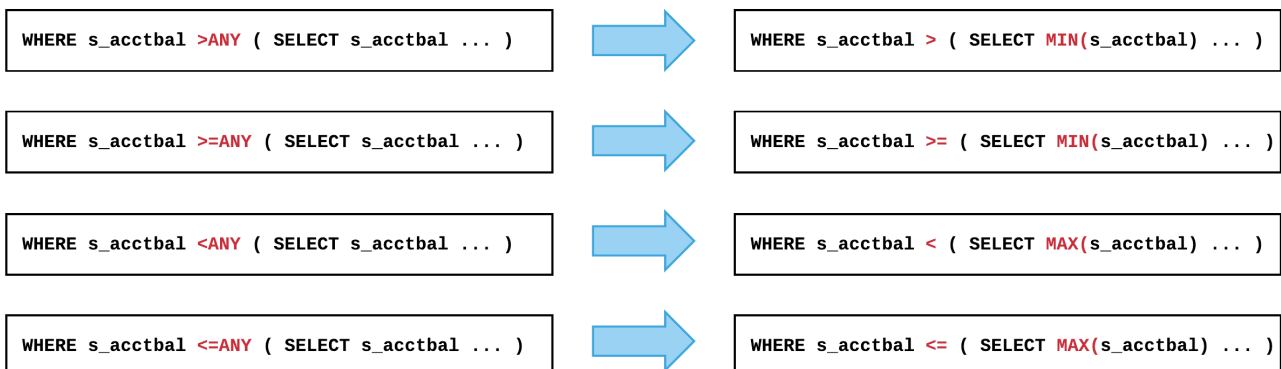

The following is an example of eliminating a quantifier.

```

\EXPLAIN PLAN
SELECT COUNT(*)
  FROM supplier
 WHERE s_acctbal >ANY ( SELECT s_acctbal
                        FROM supplier, nation
                        WHERE s_nationkey = n_nationkey
                        AND n_name = 'CHINA' )
;
COUNT(*)
-----
      9950
1 row selected.
>>> start print plan
< Execution Plan >
=====
|  IDX  |  NODE DESCRIPTION  |
-----|-----|
|   0   |  SELECT STATEMENT  |
|   1   |  QUERY BLOCK ("SQB_IDX_2")  |
|   2   |    TABLE ACCESS ("SUPPLIER")  |
|   3   |  SUB QUERY LIST  |
|   4   |  INLINE_VIEW ("V4")  |
|   5   |    QUERY BLOCK ("SQB_IDX_6")  |
|   6   |    AGGREGATION BY HASH  |
|   7   |      NESTED JOIN (INNER JOIN)  |
|   8   |        TABLE ACCESS ("NATION")  |
|   9   |          INDEX ACCESS ("SUPPLIER", "SUPPLIER_NATIONKEY_FK")  |
=====
1 - TARGET : COUNT(*)
2 - READ COLUMN : SUPPLIER.S_ACCTBAL
  AGGREGATION : COUNT(*)
  PHYSICAL FILTER : SUPPLIER.S_ACCTBAL > V4.$C0
4 - COLUMN : MIN( SUPPLIER.S_ACCTBAL ) AS $C0
5 - TARGET : MIN( SUPPLIER.S_ACCTBAL )
6 - AGGREGATION : MIN( SUPPLIER.S_ACCTBAL )
7 - JOINED COLUMN : SUPPLIER.S_ACCTBAL
8 - READ COLUMN : NATION.N_NATIONKEY, NATION.N_NAME
  PHYSICAL FILTER : NATION.N_NAME = 'CHINA'
9 - READ INDEX COLUMN : SUPPLIER.S_NATIONKEY

```

```

READ TABLE COLUMN : SUPPLIER.S_ACCTBAL
MIN RANGE : SUPPLIER.S_NATIONKEY = {NATION.N_NATIONKEY}
MAX RANGE : SUPPLIER.S_NATIONKEY = {NATION.N_NATIONKEY}

```

```
<<< end print plan
```

## Transitive Closure

It creates a constant condition in another table by using a join condition. In this way, the throughput of join is decreased and the performance is improved.

The following is an example of a transitive closure.

Figure 11 Transitive closure

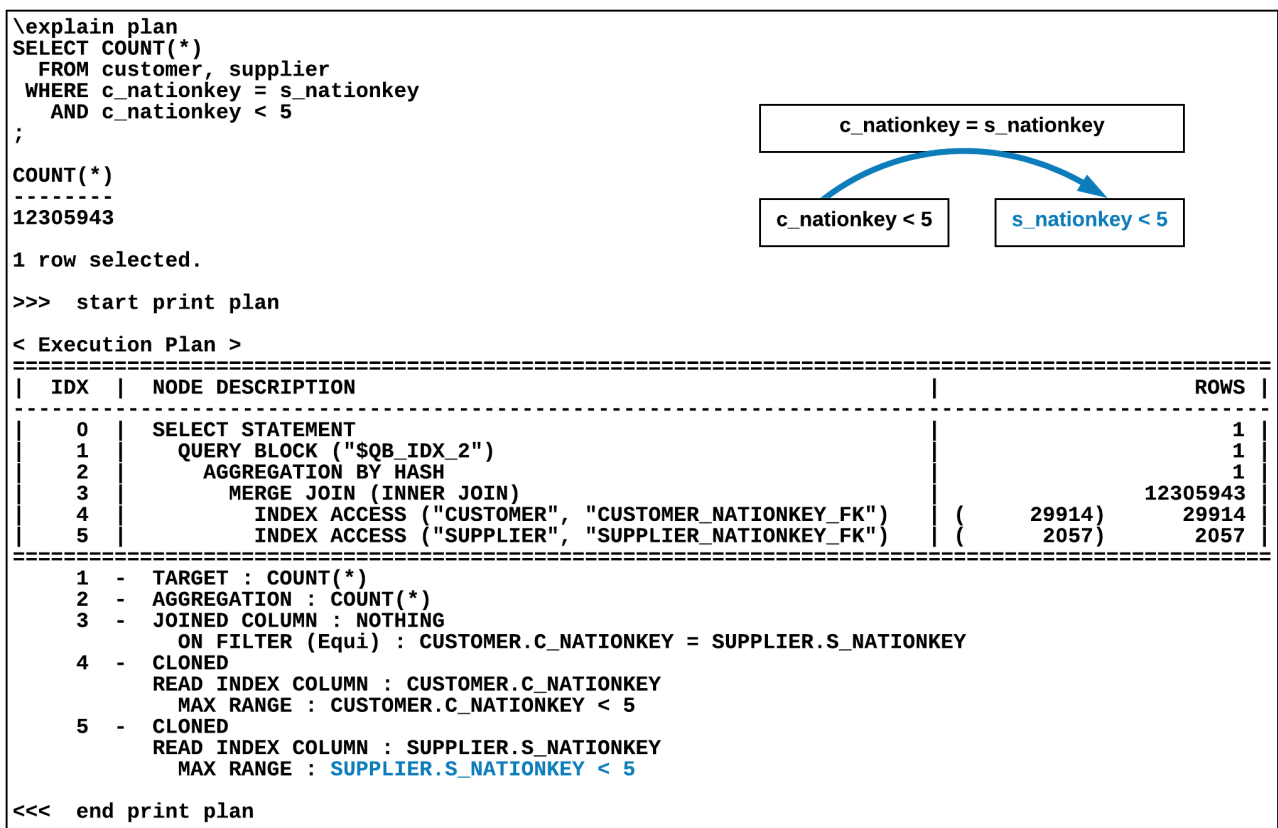

## Join Transitive Closure

It creates a join condition in another table by using a join condition. Various join orderings and join methods are available, so a better execution plan can be made.

It is performed in a way of adding a join condition ( $A=C$ ) to the other join condition ( $A = B \text{ AND } B = C$ ).



The following is an example of a join transitive closure.

Figure 12 Join transitive closure

```
\explain plan
select
  n_name,
  ROUND( sum(l_extendedprice * (1 - l_discount)), 2) as revenue
from
  customer,
  orders,
  lineitem,
  supplier,
  nation,
  region
where
  c_custkey = o_custkey
  and l_orderkey = o_orderkey
  and l_suppkey = s_suppkey
  and c_nationkey = s_nationkey
  and s_nationkey = n_nationkey
  and n_regionkey = r_regionkey
  and r_name = 'ASIA'
  and o_orderdate >= date '1994-01-01'
  and o_orderdate < date '1994-01-01' + interval '1' year
group by
  n_name
order by
  revenue desc;

N_NAME          REVENUE
-----
INDONESIA        55502041.17
VIETNAM         55295087.00
CHINA           53724494.26
INDIA           52035512.00
JAPAN           45410175.70

5 rows selected.
```

```
c_nationkey = s_nationkey
s_nationkey = n_nationkey
```



Add a new join predicate.

```
c_nationkey = s_nationkey
s_nationkey = n_nationkey
c_nationkey = n_nationkey
```



Choose a better join predicate.

```
s_nationkey = n_nationkey
c_nationkey = n_nationkey
```

```
>>> start print plan
< Execution Plan >
=====
|  IDX  |  NODE DESCRIPTION
|-----|-----
|  0    |  SELECT STATEMENT
|  1    |    QUERY BLOCK ("SQB_IDX_2")
|  2    |    SORT INSTANT
|  3    |    SINGLE CLUSTER
|  4    |    SELECT STATEMENT
|  5    |      QUERY BLOCK ("SQB_IDX_2")
|  6    |      GROUP HASH INSTANT
|  7    |        HASH JOIN (INNER JOIN)
|  8    |          NESTED JOIN (INNER JOIN)
|  9    |            NESTED JOIN (INNER JOIN)
| 10    |              NESTED JOIN (INNER JOIN)
| 11    |                NESTED JOIN (INNER JOIN)
| 12    |                  TABLE ACCESS ("REGION" AS _A6)
| 13    |                    INDEX ACCESS ("NATION" AS _A5, "NATION_REGIONKEY_FK")
| 14    |                      INDEX ACCESS ("CUSTOMER" AS _A4, "CUSTOMER_NATIONKEY_FK")
| 15    |                        INDEX ACCESS ("ORDERS" AS _A3, "ORDERS_CUSTKEY_FK")
| 16    |                          INDEX ACCESS ("LINEITEM" AS _A2, "LINEITEM_ORDERKEY_FK")
| 17    |                            HASH JOIN INSTANT
| 18    |                              TABLE ACCESS ("SUPPLIER" AS _A1)
|-----|-----
|  1    |  - TARGET : NATION.N_NAME, ROUND(SUM(LINEITEM.L_EXTENDEDPRICE * (1 - LINEITEM.L_DISCOUNT)),2) AS REVENUE
|  ...  |
|  ...  |
|  ...  |
| 14    |  - CLONED
|      |    READ INDEX COLUMN : _A4.C_NATIONKEY
|      |    READ TABLE COLUMN : _A4.C_CUSTKEY
|      |    MIN RANGE : _A4.C_NATIONKEY = {_A5.N_NATIONKEY}
|      |    MAX RANGE : _A4.C_NATIONKEY = {_A5.N_NATIONKEY}
|  ...  |
|  ...  |
|  ...  |
| 17    |  - HASH KEY : _A1.S_SUPPKEY, _A1.S_NATIONKEY
|      |    READ KEY COLUMN : _A1.S_SUPPKEY, _A1.S_NATIONKEY
|      |    HASH FILTER : _A1.S_SUPPKEY = _A2.L_SUPPKEY AND _A1.S_NATIONKEY = _A5.N_NATIONKEY
|      |    FETCH ONE ROW
| 18    |  - CLONED
|      |    READ COLUMN : _A1.S_SUPPKEY, _A1.S_NATIONKEY
<<< end print plan
```

## Subquery Unnesting

A subquery unnesting converts a subquery in a conditional clause into a join statement guaranteeing the same result. It enables to select various access path, join method, join order, so a better execution plan can be made.

Subqueries are classified into the following two types.

- Nested subquery (Regular non-scalar subquery )
  - EXISTS/NOT EXIST subquery
  - Comparison operator ( =, >, >=, <, <=, <> ) ANY subquery
  - Comparison operator ( =, >, >=, <, <=, <> ) ALL subquery
  - IN/NOT IN subquery
- Scalar subquery: It is used in WHERE clause or a SELECT list, and returns only a single result.

Not all subqueries are unnested. The subquery can be unnested only when it satisfies the following constraints.

- It should not include set operator.
- A scalar subquery is available only when it is specified on WHERE clause.
- It should include a correlated predicate.

A correlated predicate is a predicate including a column of an undefined outer query block in a subquery. In the example below, *c.cust\_id* is a correlated column and *s.cust\_id = c.cust\_id* is a correlated predicate.

```
SELECT C.cust_last_name, C.country_id
FROM   customers C
WHERE  EXISTS (SELECT 1
              FROM   sales S
              WHERE  S.quantity_sold > 1000
              AND   S.cust_id = C.cust_id);
```

## Nested Subquery Unnesting

It converts a subquery into a semi join, an anti-join, or an inner join.

Figure 13 Nested subquery unnesting

```
SELECT COUNT(*)
FROM customer
WHERE c_custkey IN ( SELECT o_custkey
                    FROM orders
                    WHERE o_orderdate = DATE'1997-02-01'
                    )
```

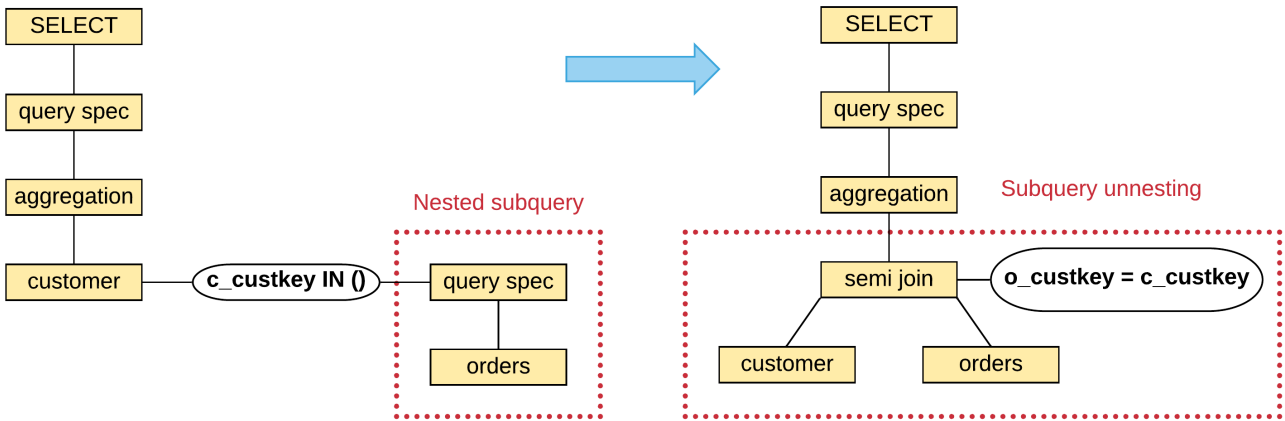

Figure 14 Nested subquery unnesting plan

```
>>> start print plan
< Execution Plan >
=====
|  IDX  |  NODE DESCRIPTION  |
|-----|-----|
|  0  |  SELECT STATEMENT  |
|  1  |  QUERY BLOCK ("SQB_IDX_2")  |
|  2  |  AGGREGATION BY HASH  |
|  3  |  MULTIPLE CLUSTER  |
|  4  |  SELECT STATEMENT  |
|  5  |  QUERY BLOCK ("SQB_IDX_2")  |
|  6  |  SORT INSTANT  |
|  7  |  NESTED JOIN (INVERTED SEMI)  |
|  8  |  SORT JOIN INSTANT (UNIQUE)  |
|  9  |  TABLE ACCESS ("ORDERS" AS _A2)  |
| 10  |  INDEX ACCESS ("CUSTOMER" AS _A1, "CUSTOMER_PK_INDEX")  |
|-----|-----|
|  1  |  - TARGET : COUNT(*)  |
|  2  |  - AGGREGATION : COUNT(*)  |
|  ...  |  |
|  ...  |  |
|  ...  |  |
| 10  |  - CLONED  |
|      |  READ INDEX COLUMN : _A1.C_CUSTKEY  |
|      |  MIN RANGE : _A1.C_CUSTKEY = {_A2.O_CUSTKEY}  |
|      |  MAX RANGE : _A1.C_CUSTKEY = {_A2.O_CUSTKEY}  |
|      |  FETCH ONE ROW  |
<<< end print plan
```

## Scalar Subquery Unnesting

It can unnest only a scalar subquery in WHERE clause, and the following conditions should be satisfied.

- It should be a single row aggregation

- It should include a correlated predicate.

The following is an example of unnesting a scalar subquery.

Figure 15 Scalar subquery unnesting

```
\explain plan
SELECT ps_suppkey
  FROM partsupp,
       part
 WHERE ps_partkey = p_partkey
       AND p_name like 'forest%'
       AND ps_availqty > ( SELECT 0.5 * sum(l_quantity)
                           FROM lineitem
                           WHERE l_partkey = ps_partkey
                             AND l_suppkey = ps_suppkey
                             AND l_shipdate >= date'1994-01-01'
                             AND l_shipdate < date'1994-01-01' + interval '1' year
                           )
;
```



```
\explain plan
SELECT ps_suppkey
  FROM partsupp,
       part,
       ( SELECT l_partkey,
               l_suppkey,
               0.5 * sum(l_quantity) as qty
         FROM lineitem
         WHERE l_shipdate >= date'1994-01-01'
               AND l_shipdate < date'1994-01-01' + interval '1' year
         GROUP BY l_partkey, l_suppkey
       )
 WHERE ps_partkey = p_partkey
       AND p_name like 'forest%'
       AND ps_availqty > v1.qty
       AND l_partkey = ps_partkey
       AND l_suppkey = ps_suppkey
;
```

Figure 16 Scalar subquery unnesting plan

```

>>> start print plan
< Execution Plan >
=====
|  IDX  |  NODE DESCRIPTION  |
|-----|-----|
|  0  |  SELECT STATEMENT  |
|  1  |    QUERY BLOCK ("SQB_IDX_2")  |
|  2  |      NESTED JOIN (INNER JOIN)  |
|  3  |        NESTED JOIN (INNER JOIN)  |
|  4  |          TABLE ACCESS ("PART")  |
|  5  |            INDEX ACCESS ("PARTSUPP", "PARTSUPP_PARTKEY_FK")  |
|  6  |              INLINE_VIEW  |
|  7  |                QUERY BLOCK ("SQB_IDX_8")  |
|  8  |                  GROUP  |
|  9  |                    INDEX ACCESS ("LINEITEM", "LINEITEM_PARTKEY_SUPPKEY_FK")  |
|-----|-----|
1 - TARGET : PARTSUPP.PS_SUPPKEY
2 - JOINED COLUMN : PARTSUPP.PS_SUPPKEY
3 - JOINED COLUMN : PARTSUPP.PS_PARTKEY, PARTSUPP.PS_SUPPKEY, PARTSUPP.PS_AVAILQTY
4 - READ COLUMN : PART.P_PARTKEY, PART.P_NAME
   LOGICAL FILTER : PART.P_NAME LIKE 'forest%'
5 - READ INDEX COLUMN : PARTSUPP.PS_PARTKEY
   READ TABLE COLUMN : PARTSUPP.PS_SUPPKEY, PARTSUPP.PS_AVAILQTY
   MIN RANGE : PARTSUPP.PS_PARTKEY = {PART.P_PARTKEY}
   MAX RANGE : PARTSUPP.PS_PARTKEY = {PART.P_PARTKEY}
6 - COLUMN : LINEITEM.L_PARTKEY AS L_PARTKEY,
   LINEITEM.L_SUPPKEY AS L_SUPPKEY,
   0.5 * SUM( LINEITEM.L_QUANTITY ) AS $C2
7 - TARGET : LINEITEM.L_PARTKEY,
   LINEITEM.L_SUPPKEY,
   0.5 * SUM( LINEITEM.L_QUANTITY )
8 - GROUP KEY : LINEITEM.L_PARTKEY, LINEITEM.L_SUPPKEY
   RECORD COLUMN : SUM( LINEITEM.L_QUANTITY )
   LOGICAL FILTER : {PARTSUPP.PS_AVAILQTY} > ( 0.5 * SUM(LINEITEM.L_QUANTITY) )
9 - READ INDEX COLUMN : LINEITEM.L_PARTKEY, LINEITEM.L_SUPPKEY
   READ TABLE COLUMN : LINEITEM.L_QUANTITY, LINEITEM.L_SHIPDATE
   MIN RANGE : LINEITEM.L_PARTKEY = {PARTSUPP.PS_PARTKEY}
   AND LINEITEM.L_SUPPKEY = {PARTSUPP.PS_SUPPKEY}
   MAX RANGE : LINEITEM.L_PARTKEY = {PARTSUPP.PS_PARTKEY}
   AND LINEITEM.L_SUPPKEY = {PARTSUPP.PS_SUPPKEY}
   PHYSICAL TABLE FILTER : LINEITEM.L_SHIPDATE < DATE'1994-01-01' + CAST( '1'
AS INTERVAL(YEAR) ) AND LINEITEM.L_SHIPDATE >= DATE'1994-01-01'
<<< end print plan
;

```

## Complex View Merging

It merges a view including *group by* with a superordinate query block.

A complex view merging is useful when *group by* can not decrease the intermediate results a lot and the join filtering with a superordinate query block is effective. In other words, if a complex view merging is used when *group by* can decrease the intermediate results a lot, then it may degrade the performance.

A complex view merging can not be applied in the following cases.

- When a query block within a view includes the following item
  - SET operator
  - ROWNUM
  - LIMIT/OFFSET
  - Single row aggregation

- ORDER BY
- SELECT list including a subquery
- FULL OUTER JOIN
- NATURAL JOIN
- When a view participates in the following query
  - Join other than an inner join
  - An equi join predicate does not exist

The following is an example of merging a complex view.

Figure 17 Complex view merging

```
\explain plan
SELECT ps_suppkey
  FROM partsupp,
       part,
       ( SELECT l_partkey,
              l_suppkey,
              0.5 * sum(l_quantity) qty
         FROM lineitem
        WHERE l_shipdate >= date'1994-01-01'
              AND l_shipdate < date'1994-01-01' + interval '1' year
        GROUP BY l_partkey, l_suppkey
       ) v1
 WHERE ps_partkey = p_partkey
       AND p_name like 'forest%'
       AND l_partkey = ps_partkey
       AND l_suppkey = ps_suppkey
       AND ps_availqty > v1.qty
;
```



```
\explain plan
SELECT ps_suppkey
  FROM ( SELECT MAX(ps_suppkey) as ps_suppkey
         FROM lineitem,
              partsupp,
              part
        WHERE ps_partkey = p_partkey
              AND p_name like 'forest%'
              AND l_partkey = ps_partkey
              AND l_suppkey = ps_suppkey
              AND l_shipdate >= date'1994-01-01'
              AND l_shipdate < date'1994-01-01' + interval '1' year
        GROUP BY l_partkey, l_suppkey, partsupp.rowid, part.rowid
        HAVING MAX(ps_availqty) > 0.5 * sum(l_quantity)
       ) v1;
;
```

Figure 18 Complex view merging plan

```

< Execution Plan >
-----
|  IDX  |  NODE DESCRIPTION  |
-----
0	SELECT STATEMENT
1	QUERY BLOCK ("SQB_IDX_2")
2	INLINE_VIEW ("V1")
3	QUERY BLOCK ("SQB_IDX_9")
4	GROUP HASH INSTANT
5	NESTED JOIN (INNER JOIN)
6	NESTED JOIN (INNER JOIN)
7	TABLE ACCESS ("PART")
8	INDEX ACCESS ("LINEITEM", "LINEITEM_PARTKEY_SUPPKEY_FK")
9	INDEX ACCESS ("PARTSUPP", "PARTSUPP_PK_INDEX")
-----
1 - TARGET : V1.PS_SUPPKEY
2 - COLUMN : PS_SUPPKEY AS PS_SUPPKEY
3 - TARGET : MAX( PARTSUPP.PS_SUPPKEY ) AS PS_SUPPKEY
4 - GROUP KEY : LINEITEM.L_PARTKEY, LINEITEM.L_SUPPKEY, PARTSUPP.$PHYSICAL_ROWID, PART.$PHYSICAL_ROWID
   RECORD COLUMN : SUM( LINEITEM.L_QUANTITY ), MAX( PARTSUPP.PS_SUPPKEY )
   READ RECORD COLUMN : SUM( LINEITEM.L_QUANTITY ), MAX( PARTSUPP.PS_SUPPKEY )
   LOGICAL FILTER : PARTSUPP.PS_AVAILQTY > ( 0.5 * SUM( LINEITEM.L_QUANTITY ) )
5 - JOINED COLUMN : LINEITEM.L_PARTKEY, LINEITEM.L_SUPPKEY, PARTSUPP.$PHYSICAL_ROWID, PART.$PHYSICAL_ROWID,
PARTSUPP.PS_AVAILQTY, LINEITEM.L_QUANTITY, PARTSUPP.PS_SUPPKEY
6 - JOINED COLUMN : PART.P_PARTKEY, LINEITEM.L_PARTKEY, LINEITEM.L_SUPPKEY, PART.$PHYSICAL_ROWID,
LINEITEM.L_QUANTITY
7 - READ COLUMN : PART.P_PARTKEY, PART.P_NAME
   LOGICAL FILTER : PART.P_NAME LIKE 'forest%'
8 - READ INDEX COLUMN : LINEITEM.L_PARTKEY, LINEITEM.L_SUPPKEY
   READ TABLE COLUMN : LINEITEM.L_QUANTITY, LINEITEM.L_SHIPDATE
   MIN RANGE : LINEITEM.L_PARTKEY = {PART.P_PARTKEY}
   MAX RANGE : LINEITEM.L_PARTKEY = {PART.P_PARTKEY}
   PHYSICAL TABLE FILTER : LINEITEM.L_SHIPDATE < DATE'1994-01-01' + CAST( '1' AS INTERVAL(YEAR) ) AND
LINEITEM.L_SHIPDATE >= DATE'1994-01-01'
9 - READ INDEX COLUMN : PARTSUPP.PS_PARTKEY, PARTSUPP.PS_SUPPKEY
   READ TABLE COLUMN : PARTSUPP.PS_AVAILQTY
   MIN RANGE : PARTSUPP.PS_PARTKEY = {PART.P_PARTKEY} AND
PARTSUPP.PS_PARTKEY = {LINEITEM.L_PARTKEY} AND
PARTSUPP.PS_SUPPKEY = {LINEITEM.L_SUPPKEY}
   MAX RANGE : PARTSUPP.PS_PARTKEY = {PART.P_PARTKEY} AND
PARTSUPP.PS_PARTKEY = {LINEITEM.L_PARTKEY} AND
PARTSUPP.PS_SUPPKEY = {LINEITEM.L_SUPPKEY}

      FETCH ONE ROW
<<< end print plan

```

## 15.3 Enumerator

An enumerator calculates the cost based on statistics information to find the most efficient plan.

It receives a trans plan and creates various cost plans about it, then calculates the cost per each cost plan based on statistics information to select the plan of the lowest cost.

### Access Paths

An access path is a method to access a single table, and there are following four types.

- Table access
- Index access
- Rowid access
- Index concat

It calculates the cost according to the methods above, and selects an access of the lowest cost as an execution plan.

### Table Access

A table access reads all rows stored in a table in a way as they were stored.

A table access is selected in the following cases.

- When an index does not exist
- When a predicate for using an index does not exist even though an index exists (e.g. WHERE col1 + 1 = 10)
- When the table accessing cost is big because a condition for the first key column of an index does not exist (e.g. WHERE col2 > 3 when only a condition for the second column of composite index (col1, col2) exists)
- When a table access cost is smaller than an index access cost because the table data is small
- When a user gives a table access hint (e.g. FULL(t1))
- When an index selectivity is poor or the data is extremely disproportionately distributed

The following is an example of using table access.

```
\EXPLAIN PLAN  
SELECT r_regionkey, r_name
```



```

FROM region;
R_REGIONKEY R_NAME
-----
      0 AFRICA
      1 AMERICA
      2 ASIA
      3 EUROPE
      4 MIDDLE EAST
5 rows selected.
>>> start print plan
< Execution Plan >
=====
|  IDX  |  NODE DESCRIPTION          |
-----|-----|
|    0  |  SELECT STATEMENT         |
|    1  |    QUERY BLOCK ("QB_IDX_2") |
|    2  |      TABLE ACCESS ("REGION") |
=====
      1 - TARGET : REGION.R_REGIONKEY, REGION.R_NAME
      2 - READ COLUMN : REGION.R_REGIONKEY, REGION.R_NAME
<<< end print plan

```

## Index Access

An index access uses an index to read a table.

Index access types are an index full scan, an index unique scan, an index range scan and an in key range scan, and the best type is selected by the cost estimation.

### Index Full Scan

It fully scans the index.

The following is an example of an index full scan.

```

\EXPLAIN PLAN
SELECT p_partkey
FROM part;
...
200000 rows selected.
>>> start print plan
< Execution Plan >
=====

```

```

IDX	NODE DESCRIPTION
0	SELECT STATEMENT
1	QUERY BLOCK ("QB_IDX_2")
2	INDEX ACCESS ("PART", "PART_PK_INDEX")
=====|=====|
      1 - TARGET : PART.P_PARTKEY
      2 - READ INDEX COLUMN : PART.P_PARTKEY
<<< end print plan

```

It retrieves p\_partkey which is a key column of PART\_PK\_INDEX only, so making the result by the index full scan costs less than the table full scan.

## Index Unique Scan

It fetches only one row through the index.

The following is an example of an index unique scan.

```

\EXPLAIN PLAN
SELECT *
  FROM part
 WHERE p_partkey = 1;
...
1 row selected.
>>> start print plan
< Execution Plan >
=====|=====|
|  IDX  |  NODE DESCRIPTION          |
-----|-----|
|    0  |  SELECT STATEMENT         |
|    1  |    QUERY BLOCK ("QB_IDX_2") |
|    2  |      INDEX ACCESS ("PART", "PART_PK_INDEX") |
=====|=====|
      1 - TARGET : PART.P_PARTKEY, PART.P_NAME, PART.P_MFGR, PART.P_BRAND,
          PART.P_TYPE, PART.P_SIZE, PART.P_CONTAINER,
          PART.P_RETAILPRICE, PART.P_COMMENT
      2 - READ INDEX COLUMN : PART.P_PARTKEY
          READ TABLE COLUMN : PART.P_NAME, PART.P_MFGR, PART.P_BRAND,
                                PART.P_TYPE, PART.P_SIZE, PART.P_CONTAINER,
                                PART.P_RETAILPRICE, PART.P_COMMENT
      MIN RANGE : PART.P_PARTKEY = 1

```

```

MAX RANGE : PART.P_PARTKEY = 1
FETCH ONE ROW
<<< end print plan

```

## Index Range Scan

It reads rows in the range satisfying a predicate condition through an index. The result rows are sorted for an index key column because they are read through the index.

The following is an example of an index range scan.

```

\EXPLAIN PLAN
SELECT p_partkey, p_brand, p_type
  FROM part
 WHERE p_partkey >= 10
        AND p_partkey < 20;
P_PARTKEY P_BRAND    P_TYPE
-----
10 Brand#54  LARGE BURNISHED STEEL
11 Brand#25  STANDARD BURNISHED NICKEL
12 Brand#33  MEDIUM ANODIZED STEEL
13 Brand#55  MEDIUM BURNISHED NICKEL
14 Brand#13  SMALL POLISHED STEEL
15 Brand#15  LARGE ANODIZED BRASS
16 Brand#32  PROMO PLATED TIN
17 Brand#43  ECONOMY BRUSHED STEEL
18 Brand#11  SMALL BURNISHED STEEL
19 Brand#23  SMALL ANODIZED NICKEL
10 rows selected.
>>> start print plan
< Execution Plan >
=====
|  IDX  |  NODE DESCRIPTION  |
-----
0	SELECT STATEMENT
1	QUERY BLOCK ("SQB_IDX_2")
2	INDEX ACCESS ("PART", "PART_PK_INDEX")
=====
1 - TARGET : PART.P_PARTKEY, PART.P_BRAND, PART.P_TYPE
2 - READ INDEX COLUMN : PART.P_PARTKEY
  READ TABLE COLUMN : PART.P_BRAND, PART.P_TYPE
  MIN RANGE : PART.P_PARTKEY >= 10

```

```
MAX RANGE : PART.P_PARTKEY IS NOT NULL AND PART.P_PARTKEY < 20
```

```
<<< end print plan
```

## In Key Range Scan

An in key range scan is available when the following predicate exists.

```
( col1, col2 ) IN ( (val1, val2), (val3, val4) )
```

- IN or =ANY list function filter exists in WHERE clause.
- col1 and col2 should be base columns. (It should be a column without an operation or a function.)
- (val1, val3) corresponding to col1 should be convertible to a single data type.
- (val2, val4) corresponding to col2 should be convertible to a single data type.

The following is an example of an in key range scan.

```
\EXPLAIN PLAN
  SELECT o_orderstatus
  FROM orders
  WHERE o_custkey IN ( 1, 10, 100, 1000, 10000 );
...
91 rows selected.
>>> start print plan
< Execution Plan >
=====
|  IDX  |  NODE DESCRIPTION  |
-----|-----|
|    0  |  SELECT STATEMENT  |
|    1  |  QUERY BLOCK ("QB_IDX_2")  |
|    2  |  INDEX ACCESS ("ORDERS", "ORDERS_CUSTKEY_FK")  |
=====
1 - TARGET : ORDERS.O_ORDERSTATUS
2 - READ INDEX COLUMN : ORDERS.O_CUSTKEY
  READ TABLE COLUMN : ORDERS.O_ORDERSTATUS
IN KEY RANGE
  MIN RANGE : ORDERS.O_CUSTKEY = ?
  MAX RANGE : ORDERS.O_CUSTKEY = ?
<<< end print plan
```

## Rowid Access

A rowid access directly accesses to the corresponding page by using a rowid.

A predicate for the rowid should exist when using the rowid access. Generally, a rowid access is faster than other access paths, so an estimator most likely to select a rowid access as the best access path as long as a predicate for a rowid exists.

```
gSQL> \EXPLAIN PLAN
SELECT p_brand, p_type
  FROM part
 WHERE rowid = 'AAAAAAAAYe8AACAAEMJAAA';
P_BRAND  P_TYPE
-----  -----
Brand#33  STANDARD POLISHED COPPER
1 row selected.
>>> start print plan
< Execution Plan >
=====
|  IDX  |  NODE DESCRIPTION  |
-----  -----
0	SELECT STATEMENT
1	QUERY BLOCK ("QB_IDX_2")
2	ROWID ACCESS ("PART")
=====
1 - TARGET : PART.P_BRAND, PART.P_TYPE
2 - READ COLUMN : PART.P_BRAND, PART.P_TYPE
   ROWID FILTER : PART.ROWID = 'AAAAAAAAYe8AACAAEMJAAA'
<<< end print plan
```

## Index Concat

An index concat integrates results of index access, and makes it into a single result. Therefore, it can be used only when OR predicate exists and each predicate can use an index access.

If OR predicate exists, an estimator calculates the cost of index concat, and selects the method when the cost is smaller than that of other access paths.

The following is an example of using an index concat.

```
gSQL> \EXPLAIN PLAN
SELECT p_brand, p_type
  FROM part
```

```
WHERE p_partkey = 1 OR p_partkey = 20;
```

```
P_BRAND    P_TYPE
```

```
-----
```

```
Brand#13   PROMO BURNISHED COPPER
```

```
Brand#12   LARGE POLISHED NICKEL
```

```
2 rows selected.
```

```
>>> start print plan
```

```
< Execution Plan >
```

```
=====
```

| IDX | NODE DESCRIPTION                       |
|-----|----------------------------------------|
| 0   | SELECT STATEMENT                       |
| 1   | QUERY BLOCK ("QB_IDX_2")               |
| 2   | CONCAT (Compare Nothing)               |
| 3   | INDEX ACCESS ("PART", "PART_PK_INDEX") |
| 4   | INDEX ACCESS ("PART", "PART_PK_INDEX") |

```
=====
```

```
1 - TARGET : PART.P_BRAND, PART.P_TYPE
```

```
2 - CONCAT COLUMN : PART.P_BRAND, PART.P_TYPE
```

```
3 - READ INDEX COLUMN : PART.P_PARTKEY
```

```
   READ TABLE COLUMN : PART.P_BRAND, PART.P_TYPE
```

```
   MIN RANGE : PART.P_PARTKEY = 1
```

```
   MAX RANGE : PART.P_PARTKEY = 1
```

```
   FETCH ONE ROW
```

```
4 - READ INDEX COLUMN : PART.P_PARTKEY
```

```
   READ TABLE COLUMN : PART.P_BRAND, PART.P_TYPE
```

```
   MIN RANGE : PART.P_PARTKEY = 20
```

```
   MAX RANGE : PART.P_PARTKEY = 20
```

```
   FETCH ONE ROW
```

```
<<< end print plan
```

## Join

Join combines two or more tables to make them into a single result set.

In this case, a join condition defines the relation between tables. If a join condition does not exist, then multiplying rows of every table compose a new result set.

An estimator creates various cost plans considering join order, join method, and access path according to the join type, and calculates a cost, then selects the best cost plan. **Access Paths** are described in a chapter

r above and this chapter describes a join type, a join method and a join order.

# Join Type

## Cross Join

A join condition does not exist. Therefore, a multiplication set of two tables composes a new result of join.

The following is an example of a cross join.

```

gSQL> \EXPLAIN PLAN SELECT r_regionkey, n_nationkey FROM region, nation;
R_REGIONKEY N_NATIONKEY
-----
0          0
0          1
0          2
0          3
0          4
0          5
0          6
0          7
0          8
0          9
0         10
0         11
0         12
0         13
0         14
0         15
0         16
0         17
0         18
0         19
R_REGIONKEY N_NATIONKEY
-----
0          20
0          21
0          22
0          23
0          24
1          0

```

```

      1      1
      ...    ...
      4      24

```

125 rows selected.

```
>>> start print plan
```

```
< Execution Plan >
```

```

=====
|  IDX  |  NODE DESCRIPTION                                |
-----
0	SELECT STATEMENT
1	QUERY BLOCK ("QB_IDX_2")
2	NESTED JOIN (INNER JOIN)
3	INDEX ACCESS ("REGION", "REGION_PK_INDEX")
4	INDEX ACCESS ("NATION", "NATION_PK_INDEX")
=====

```

```

1 - TARGET : REGION.R_REGIONKEY, NATION.N_NATIONKEY
2 - JOINED COLUMN : REGION.R_REGIONKEY, NATION.N_NATIONKEY
3 - READ INDEX COLUMN : REGION.R_REGIONKEY
4 - READ INDEX COLUMN : NATION.N_NATIONKEY

```

```
<<< end print plan
```

## Inner Join

Only the rows satisfying a join condition from a multiplication set of two tables configure a result set.

The following is an example of an inner join.

```

gSQL> \EXPLAIN PLAN
SELECT r_regionkey, n_nationkey
   FROM region, nation
   WHERE r_regionkey = n_nationkey;

```

```

R_REGIONKEY N_NATIONKEY
-----
      0      0
      1      1
      2      2
      3      3
      4      4

```

5 rows selected.

```
>>> start print plan
```

```
< Execution Plan >
```

```
=====
```



```

IDX	NODE DESCRIPTION
0	SELECT STATEMENT
1	QUERY BLOCK ("QB_IDX_2")
2	NESTED JOIN (INNER JOIN)
3	INDEX ACCESS ("REGION", "REGION_PK_INDEX")
4	INDEX ACCESS ("NATION", "NATION_PK_INDEX")
=====|=====|
1 - TARGET : REGION.R_REGIONKEY, NATION.N_NATIONKEY
2 - JOINED COLUMN : REGION.R_REGIONKEY, NATION.N_NATIONKEY
3 - READ INDEX COLUMN : REGION.R_REGIONKEY
4 - READ INDEX COLUMN : NATION.N_NATIONKEY
   MIN RANGE : NATION.N_NATIONKEY = {REGION.R_REGIONKEY}
   MAX RANGE : NATION.N_NATIONKEY = {REGION.R_REGIONKEY}
   FETCH ONE ROW
<<< end print plan

```

## Outer Join

It returns rows satisfying a join condition from a multiplication set of two tables as result, and it also returns rows in an outer table as result even though the rows do not satisfy the join condition. In other words, an outer join is used to output even the rows which do not satisfy the join condition as well.

In this case, values corresponding to an inner table are NULL padded.

The left table becomes an outer table in a left outer join. Therefore, *part* which is a left table becomes an outer table so it outputs even the rows which do not satisfy the join condition as well in the example below. In this case, *partsupp* value which is an inner table is NULL padded.

Figure 19 Left outer join

```
SELECT p_partkey, ps_partkey
FROM part LEFT OUTER JOIN partsupp
ON p_partkey = ps_partkey;
```

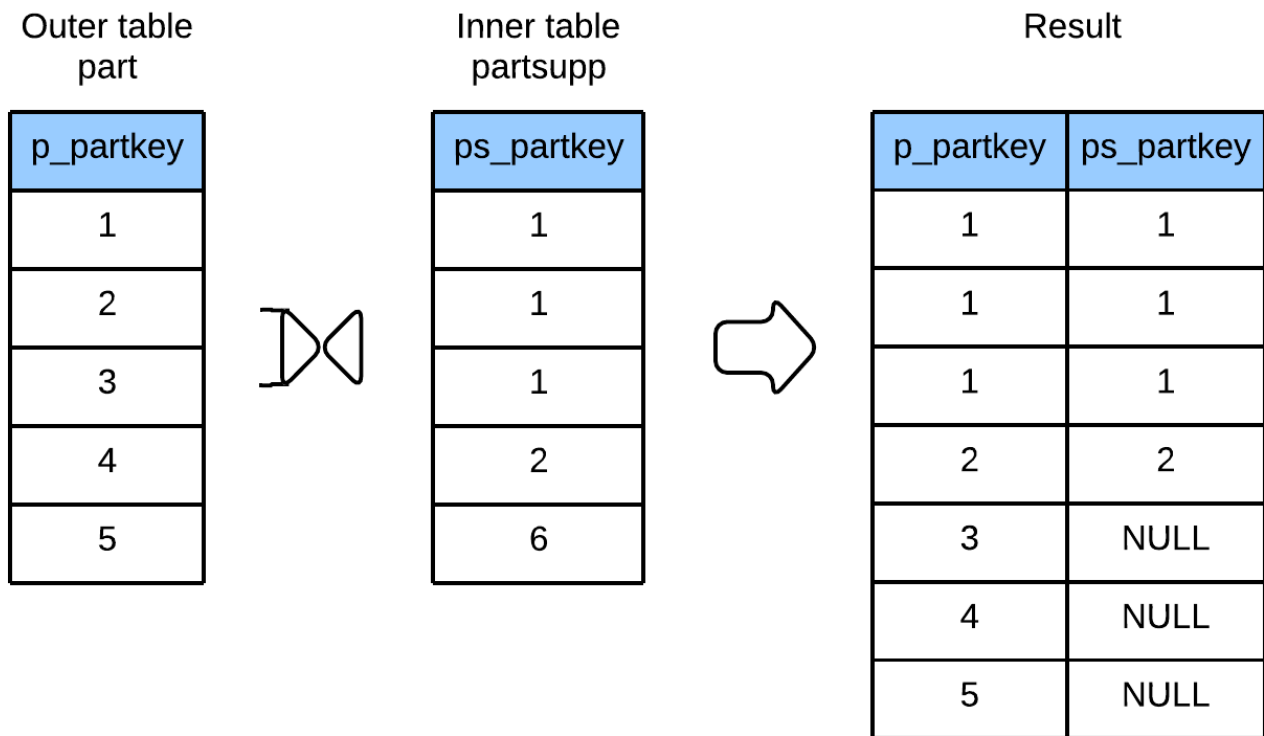

The right table becomes an outer table in a right outer join.

Therefore, *partsupp* which is a right table becomes an outer table so it outputs even the rows which do not satisfy the join condition as well in the example below. In this case, *part* value which is an inner table is NULL padded.

Figure 20 Right outer join

```
SELECT p_partkey, ps_partkey
FROM part RIGHT OUTER JOIN partsupp
ON p_partkey = ps_partkey;
```

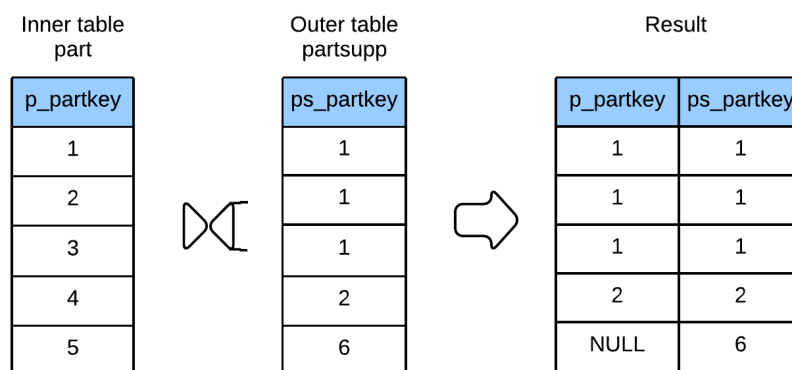

A full outer join outputs rows satisfying the join condition, then it performs left outer join and a right outer join so that it outputs all rows.

Figure 21 Full outer join

```
SELECT p_partkey, ps_partkey
FROM part FULL OUTER JOIN partsupp
ON p_partkey = ps_partkey;
```

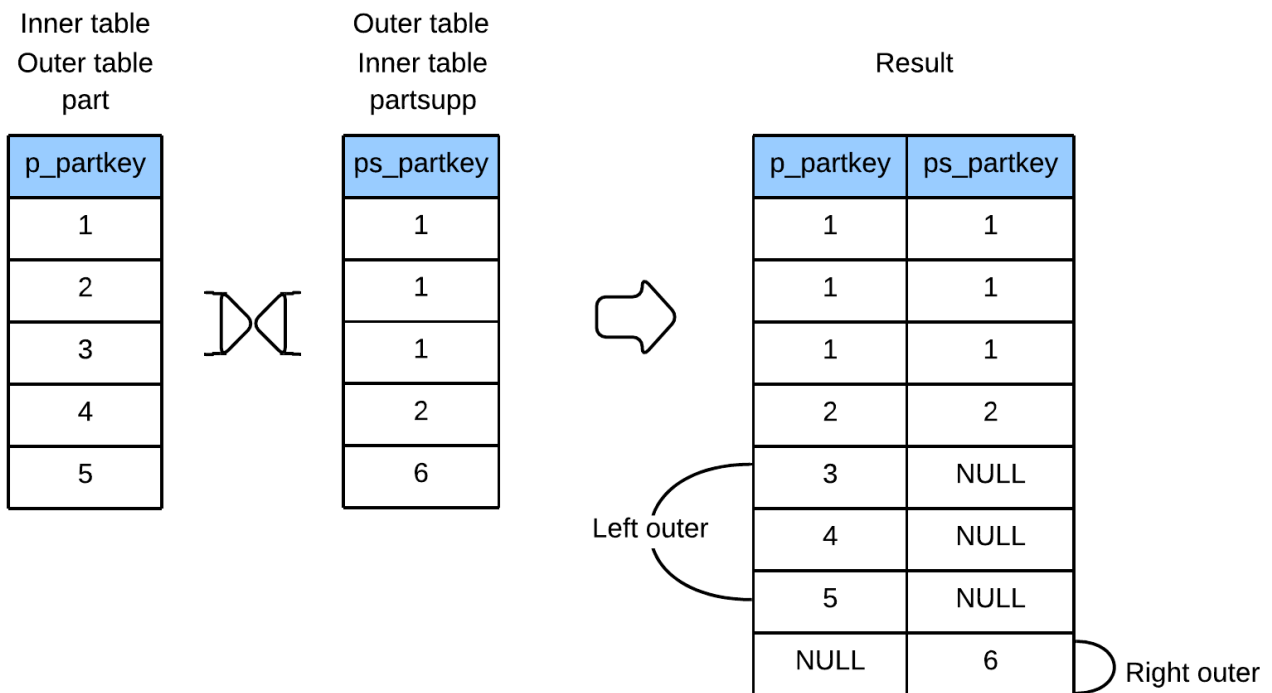

### Left Outer Join

It returns all rows satisfying a join condition as result, and also returns rows in a left table as result even though the rows do not satisfy the join condition.

The following is an example of a left outer join.

```
gSQL> \EXPLAIN PLAN
SELECT r_name, n_name
FROM region
LEFT OUTER JOIN
nation
ON r_regionkey = n_regionkey
AND n_nationkey > 20;
```

| R_NAME  | N_NAME        |
|---------|---------------|
| AFRICA  | null          |
| AMERICA | UNITED STATES |

```

ASIA                VIETNAM
EUROPE              UNITED KINGDOM
EUROPE              RUSSIA
MIDDLE EAST         null
6 rows selected.
>>> start print plan
< Execution Plan >
=====
|  IDX  |  NODE DESCRIPTION                               |
-----|-----|
|   0   |  SELECT STATEMENT                               |
|   1   |    QUERY BLOCK ("SQB_IDX_2")                   |
|   2   |      HASH JOIN (LEFT OUTER JOIN)                |
|   3   |        TABLE ACCESS ("REGION")                |
|   4   |          HASH JOIN INSTANT                       |
|   5   |            INDEX ACCESS ("NATION", "NATION_PK_INDEX")
=====

  1 - TARGET : REGION.R_NAME, NATION.N_NAME
  2 - JOINED COLUMN : REGION.R_NAME, NATION.N_NAME
  3 - READ COLUMN : REGION.R_REGIONKEY, REGION.R_NAME
  4 - HASH KEY : NATION.N_REGIONKEY
      RECORD COLUMN : NATION.N_NAME
      READ KEY COLUMN : NATION.N_REGIONKEY, NATION.N_NAME
      HASH FILTER : NATION.N_REGIONKEY = REGION.R_REGIONKEY
  5 - READ INDEX COLUMN : NATION.N_NATIONKEY
      READ TABLE COLUMN : NATION.N_NAME, NATION.N_REGIONKEY
      MIN RANGE : NATION.N_NATIONKEY > 20
      MAX RANGE : NATION.N_NATIONKEY IS NOT NULL
<<< end print plan

```

### Right Outer Join

It returns all rows satisfying a join condition as result, and also returns rows in a right table as result even though the rows do not satisfy the join condition.

The following is an example of a right outer join.

```

gSQL> \EXPLAIN PLAN
SELECT r_name, n_name
   FROM region RIGHT OUTER JOIN nation ON r_regionkey = n_regionkey
   AND n_nationkey > 20;

R_NAME N_NAME

```

```

-----
null                ALGERIA
null                ARGENTINA
null                BRAZIL
null                CANADA
null                EGYPT
null                ETHIOPIA
null                FRANCE
null                GERMANY
null                INDIA
null                INDONESIA
null                IRAN
null                IRAQ
null                JAPAN
null                JORDAN
null                KENYA
null                MOROCCO
null                MOZAMBIQUE
null                PERU
null                CHINA
null                ROMANIA
null                SAUDI ARABIA
ASIA                VIETNAM
EUROPE              RUSSIA
EUROPE              UNITED KINGDOM
AMERICA             UNITED STATES

```

25 rows selected.

>>> start print plan

< Execution Plan >

```

=====
|  IDX  |  NODE DESCRIPTION                                |
-----|-----|-----
|   0   |  SELECT STATEMENT                                |
|   1   |    QUERY BLOCK ("$_QB_IDX_2")                    |
|   2   |      HASH JOIN (LEFT OUTER JOIN)                  |
|   3   |        TABLE ACCESS ("NATION")                  |
|   4   |          HASH JOIN INSTANT                        |
|   5   |            TABLE ACCESS ("REGION")              |
=====

```

- 1 - TARGET : REGION.R\_NAME, NATION.N\_NAME
- 2 - JOINED COLUMN : REGION.R\_NAME, NATION.N\_NAME

```

3 - READ COLUMN : NATION.N_NATIONKEY, NATION.N_NAME, NATION.N_REGIONKEY
4 - HASH KEY : REGION.R_REGIONKEY
  RECORD COLUMN : REGION.R_NAME
  READ KEY COLUMN : REGION.R_REGIONKEY, REGION.R_NAME
  HASH FILTER : REGION.R_REGIONKEY = NATION.N_REGIONKEY
  LOGICAL FILTER : {NATION.N_NATIONKEY} > 20
  FETCH ONE ROW
5 - READ COLUMN : REGION.R_REGIONKEY, REGION.R_NAME
<<< end print plan

```

### Full Outer Join

It returns all rows satisfying a join condition as result, and also returns all rows in both of a left table and a right table as result even though the rows do not satisfy the join condition.

The following is an example of a full outer join.

```

gSQL> \EXPLAIN PLAN
SELECT r_name, n_name
FROM region FULL OUTER JOIN nation ON r_regionkey = n_regionkey
AND n_nationkey > 20;

```

| R_NAME | N_NAME     |
|--------|------------|
| null   | ALGERIA    |
| null   | ARGENTINA  |
| null   | BRAZIL     |
| null   | CANADA     |
| null   | EGYPT      |
| null   | ETHIOPIA   |
| null   | FRANCE     |
| null   | GERMANY    |
| null   | INDIA      |
| null   | INDONESIA  |
| null   | IRAN       |
| null   | IRAQ       |
| null   | JAPAN      |
| null   | JORDAN     |
| null   | KENYA      |
| null   | MOROCCO    |
| null   | MOZAMBIQUE |
| null   | PERU       |
| null   | CHINA      |

```

null                ROMANIA
null                SAUDI ARABIA
ASIA                VIETNAM
EUROPE              RUSSIA
EUROPE              UNITED KINGDOM
AMERICA             UNITED STATES
AFRICA              null
MIDDLE EAST        null
27 rows selected.
>>> start print plan
< Execution Plan >
=====
|  IDX  |  NODE DESCRIPTION                                |
-----|-----|
|   0   |  SELECT STATEMENT                                |
|   1   |    QUERY BLOCK ("$_QB_IDX_2")                   |
|   2   |      HASH JOIN (FULL OUTER JOIN)                |
|   3   |        TABLE ACCESS ("NATION")                 |
|   4   |          HASH JOIN INSTANT                       |
|   5   |            TABLE ACCESS ("REGION")             |
=====
1 - TARGET : REGION.R_NAME, NATION.N_NAME
2 - JOINED COLUMN : REGION.R_NAME, NATION.N_NAME
3 - READ COLUMN : NATION.N_NATIONKEY, NATION.N_NAME, NATION.N_REGIONKEY
4 - HASH KEY : REGION.R_REGIONKEY
   RECORD COLUMN : REGION.R_NAME
   READ KEY COLUMN : REGION.R_REGIONKEY, REGION.R_NAME
   HASH FILTER : REGION.R_REGIONKEY = NATION.N_REGIONKEY
   LOGICAL FILTER : {NATION.N_NATIONKEY} > 20
5 - READ COLUMN : REGION.R_REGIONKEY, REGION.R_NAME
<<< end print plan

```

## Semi Join

A semi join can not be explicitly specified by using SQL statement. When a user used a subquery together with a quantifier such as IN, EXISTS, =ANY, then a rewriter converts it to a semi join while unnesting the subquery.

When a row satisfying the join condition exists, then it returns the row of a main query as result.

The following is an example of a semi join.

```

\EXPLAIN PLAN
SELECT o_orderpriority,
       count(*) as order_count
FROM orders
WHERE o_orderdate = date '1993-07-01'
AND EXISTS (
        SELECT *
        FROM lineitem
        WHERE l_orderkey = o_orderkey
        AND l_commitdate < l_receiptdate
        )

```

```

GROUP BY o_orderpriority
ORDER BY o_orderpriority;
O_ORDERPRIORITY ORDER_COUNT
-----

```

```

1-URGENT          113
2-HIGH            136
3-MEDIUM         112
4-NOT SPECIFIED  103
5-LOW             97

```

5 rows selected.

```
>>> start print plan
```

```
< Execution Plan >
```

```

=====
|  IDX  |  NODE DESCRIPTION                                |
-----
0	SELECT STATEMENT
1	QUERY BLOCK ("$_QB_IDX_2")
2	SORT INSTANT
3	GROUP HASH INSTANT
4	NESTED JOIN (SEMI)
5	TABLE ACCESS ("ORDERS")
6	INDEX ACCESS ("LINEITEM", "LINEITEM_ORDERKEY_FK")
=====

```

- ```

1 - TARGET : ORDERS.O_ORDERPRIORITY, COUNT(*) AS ORDER_COUNT
2 - SORT KEY : "ORDERS.O_ORDERPRIORITY ASC NULLS LAST"
   RECORD COLUMN : COUNT(*)
   READ KEY COLUMN : ORDERS.O_ORDERPRIORITY
   READ RECORD COLUMN : COUNT(*)
3 - GROUP KEY : ORDERS.O_ORDERPRIORITY
   RECORD COLUMN : COUNT(*)

```



```

        READ KEY COLUMN : ORDERS.O_ORDERPRIORITY
        READ RECORD COLUMN : COUNT(*)
4 - JOINED COLUMN : ORDERS.O_ORDERPRIORITY
5 - READ COLUMN : ORDERS.O_ORDERKEY, ORDERS.O_ORDERDATE, ORDERS.O_ORDERPRIORITY
    PHYSICAL FILTER : ORDERS.O_ORDERDATE = DATE'1993-07-01'
6 - READ INDEX COLUMN : LINEITEM.L_ORDERKEY
    READ TABLE COLUMN : LINEITEM.L_COMMITDATE, LINEITEM.L_RECEIPTDATE
    MIN RANGE : LINEITEM.L_ORDERKEY = {ORDERS.O_ORDERKEY}
    MAX RANGE : LINEITEM.L_ORDERKEY = {ORDERS.O_ORDERKEY}
    PHYSICAL TABLE FILTER :
        LINEITEM.L_RECEIPTDATE > LINEITEM.L_COMMITDATE

```

```
<<< end print plan
```

## Anti Semi Join

An anti semi join can not be explicitly specified by using SQL statement. When a user used a subquery together with a quantifier such as NOT IN, NOT EXISTS, !=ALL, =ALL, then a rewriter converts it to an anti semi join while unnesting the subquery.

When a row satisfying the join condition does not exist, then it returns the row of a main query as result.

When a nullable column exists in the join condition, then it is performed as a null-aware anti-semi join. Otherwise, it is performed as an anti-semi join.

The following is an example of an anti semi join.

Both p\_partkey and ps\_partkey are primary key columns. Therefore, all of them are not null columns.

```

\EXPLAIN PLAN
SELECT p_name, p_brand
  FROM part
 WHERE p_partkey NOT IN ( SELECT ps_partkey
                        FROM partsupp
                        WHERE ps_availqty > 5000 );

```

```
...
```

```
12511 rows selected.
```

```
>>> start print plan
```

```
< Execution Plan >
```

```

=====
|  IDX  |  NODE DESCRIPTION  |
-----
|    0  |  SELECT STATEMENT  |
|    1  |  QUERY BLOCK ("QB_IDX_2")  |
|    2  |  HASH JOIN (ANTI SEMI)  |

```

```

| 3 | TABLE ACCESS ("PART") |
| 4 | HASH JOIN INSTANT (UNIQUE) |
| 5 | TABLE ACCESS ("PARTSUPP") |
=====
1 - TARGET : PART.P_NAME, PART.P_BRAND
2 - JOINED COLUMN : PART.P_NAME, PART.P_BRAND
3 - READ COLUMN : PART.P_PARTKEY, PART.P_NAME, PART.P_BRAND
4 - HASH KEY : PARTSUPP.PS_PARTKEY
   READ KEY COLUMN : PARTSUPP.PS_PARTKEY
   HASH FILTER : PARTSUPP.PS_PARTKEY = PART.P_PARTKEY
   FETCH ONE ROW
5 - READ COLUMN : PARTSUPP.PS_PARTKEY, PARTSUPP.PS_AVAILQTY
   PHYSICAL FILTER : PARTSUPP.PS_AVAILQTY > 5000
<<< end print plan

```

The following is an example of a null-aware anti-semi join.

p\_partkey is not null because it is a primary key column, but l\_partkey is nullable.

```

\EXPLAIN PLAN
SELECT p_name, p_brand
FROM part
WHERE p_partkey NOT IN ( SELECT l_partkey
                        FROM lineitem
                        WHERE l_quantity > 30 );
no rows selected.
>>> start print plan
< Execution Plan >
=====
|  IDX  |  NODE DESCRIPTION  |
-----|-----|
|  0  |  SELECT STATEMENT  |
|  1  |  QUERY BLOCK ("SQB_IDX_2") |
|  2  |  HASH JOIN (ANTI SEMI NA) |
|  3  |  TABLE ACCESS ("PART") |
|  4  |  HASH JOIN INSTANT (UNIQUE) |
|  5  |  TABLE ACCESS ("LINEITEM") |
=====
1 - TARGET : PART.P_NAME, PART.P_BRAND
2 - JOINED COLUMN : PART.P_NAME, PART.P_BRAND
3 - READ COLUMN : PART.P_PARTKEY, PART.P_NAME, PART.P_BRAND
4 - HASH KEY : LINEITEM.L_PARTKEY

```

```

READ KEY COLUMN : LINEITEM.L_PARTKEY
  HASH FILTER : LINEITEM.L_PARTKEY = PART.P_PARTKEY
  FETCH ONE ROW
5 - READ COLUMN : LINEITEM.L_PARTKEY, LINEITEM.L_QUANTITY
  PHYSICAL FILTER : LINEITEM.L_QUANTITY > 30

```

<<< end print plan

## Join Method

Join operation methods between two tables are a nested loops join, a sort merge join and a hash join. An enumerator calculates the cost for those join methods, then select the join operation of the lowest cost.

### Nested Loops Join

It scans all rows in an inner table for each row of an outer table, then retrieves results satisfying the join condition.

Figure 22 Nested loop join

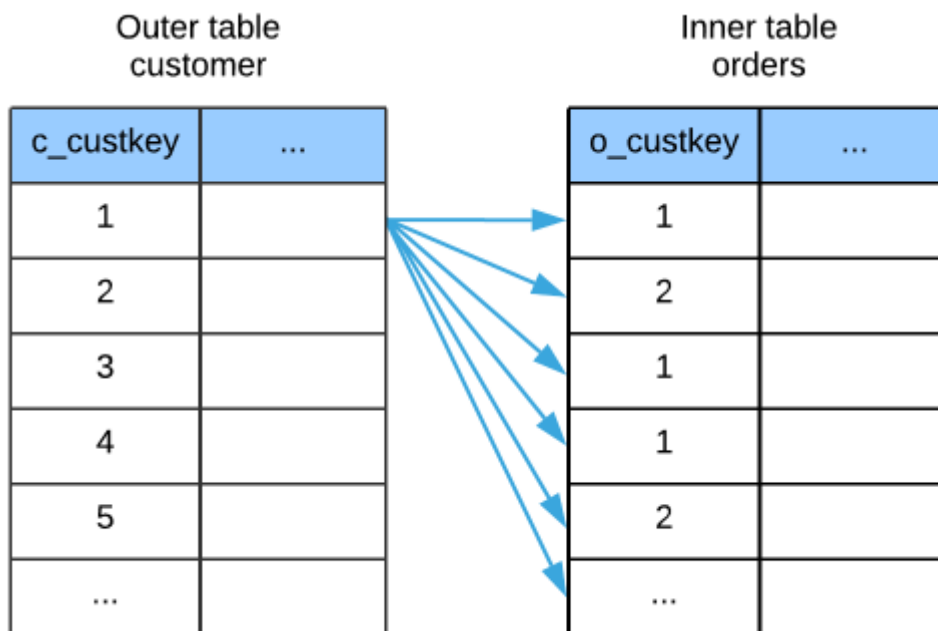

It performs the full scan for the inner table as many as the number of rows in an outer table, so the less rows in an outer table the better.

Even the join without a join condition can return the execution result to a cartesian product through a nested loop join. Therefore, a nested loop join is available even when a hash join and a sort merge join are not available.

### Index Nested Loops Join

It performs an index nested loop join when it can retrieve the row satisfying the join condition by using a n index in an inner table. An index access accesses only to necessary rows, so the performance is improved.

Figure 23 Index nested loop join

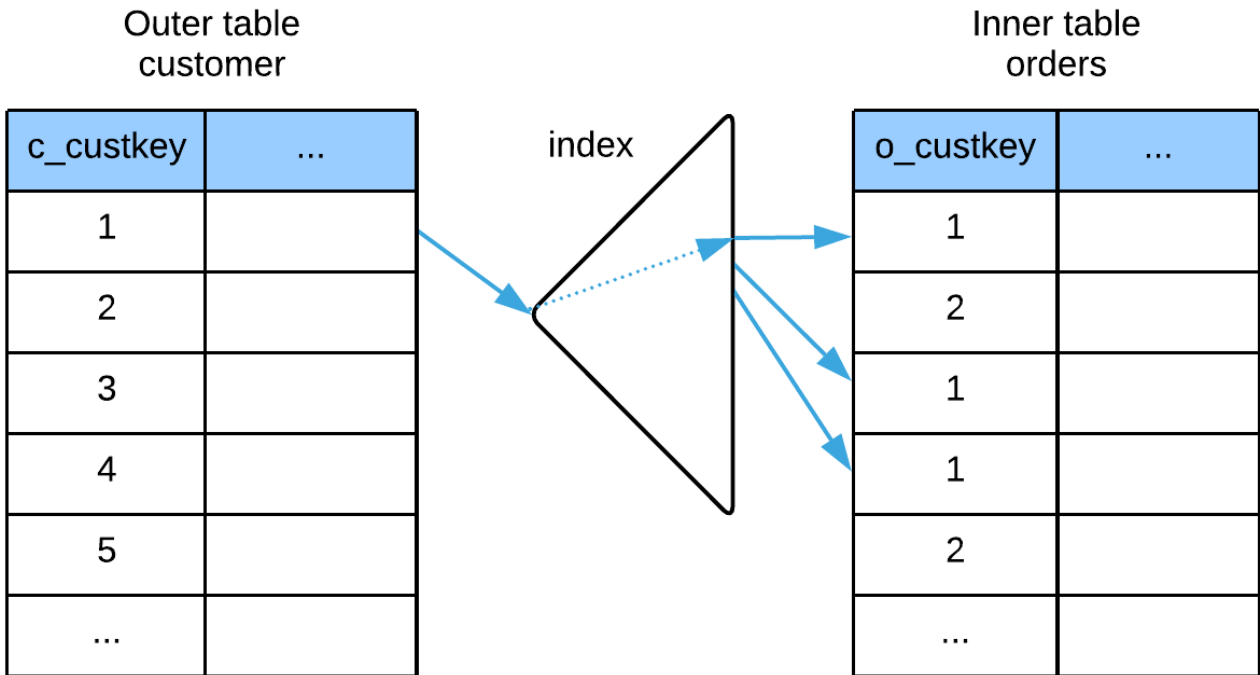

The following is an example of an index nested loop join.

```
\EXPLAIN PLAN
SELECT c_custkey, count(o_orderkey)
FROM customer, orders
WHERE c_custkey = o_custkey
AND c_comment like '%special%requests%'
GROUP BY c_custkey;
```

...  
2265 rows selected.

>>> start print plan

< Execution Plan >

```
=====
|  IDX  |  NODE DESCRIPTION  |
-----
|    0  |  SELECT STATEMENT  |
|    1  |  QUERY BLOCK ("QB_IDX_2")  |
|    2  |  GROUP HASH INSTANT  |
```

```

| 3 |          NESTED JOIN (INNER JOIN)          |
| 4 |          TABLE ACCESS ("CUSTOMER")        |
| 5 |          INDEX ACCESS ("ORDERS", "ORDERS_CUSTKEY_FK") |
=====
1 - TARGET : CUSTOMER.C_CUSTKEY, COUNT( ORDERS.O_ORDERKEY )
2 - GROUP KEY : CUSTOMER.C_CUSTKEY
  RECORD COLUMN : COUNT( ORDERS.O_ORDERKEY )
  READ KEY COLUMN : CUSTOMER.C_CUSTKEY
  READ RECORD COLUMN : COUNT( ORDERS.O_ORDERKEY )
3 - JOINED COLUMN : CUSTOMER.C_CUSTKEY, ORDERS.O_ORDERKEY
4 - READ COLUMN : CUSTOMER.C_CUSTKEY, CUSTOMER.C_COMMENT
  LOGICAL FILTER : CUSTOMER.C_COMMENT LIKE '%special%requests%'
5 - READ INDEX COLUMN : ORDERS.O_CUSTKEY
  READ TABLE COLUMN : ORDERS.O_ORDERKEY
  MIN RANGE : ORDERS.O_CUSTKEY = {CUSTOMER.C_CUSTKEY}
  MAX RANGE : ORDERS.O_CUSTKEY = {CUSTOMER.C_CUSTKEY}
<<< end print plan

```

### Instant Nested Loops Join

It performs a nested loop join after loading the intermediate result of an inner table on an instant table.

Figure 24 Instant nested loop join

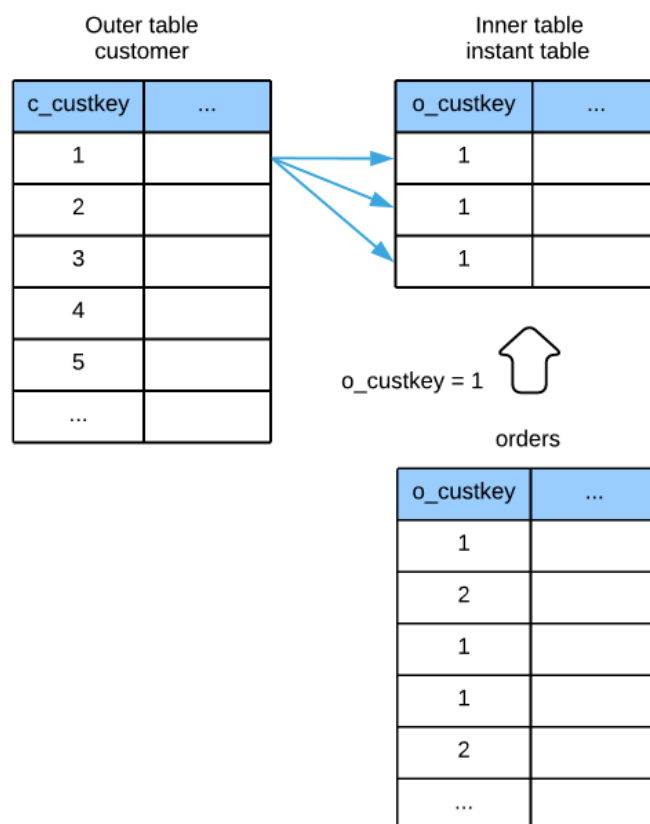

When the condition such as `o_custkey = 1` exists as the example above, a nested loop join is available by loading the intermediate result of `orders` on an instant table.

The following is an example of an instant nested loop join.

```
\EXPLAIN PLAN
  SELECT c_custkey, count(o_orderkey)
     FROM customer, orders
     WHERE c_comment like '%special%requests%'
        AND o_orderdate = date '1995-03-15'
GROUP BY c_custkey;
...
3380 rows selected.
>>> start print plan
< Execution Plan >
=====
|  IDX  |  NODE DESCRIPTION                                |
-----|-----|
|   0   |  SELECT STATEMENT                                |
|   1   |    QUERY BLOCK ("QB_IDX_2")                      |
|   2   |      GROUP HASH INSTANT                          |
|   3   |        NESTED JOIN (INNER JOIN)                |
|   4   |          TABLE ACCESS ("ORDERS")                |
|   5   |            FLAT JOIN INSTANT                    |
|   6   |              TABLE ACCESS ("CUSTOMER")          |
=====
1 - TARGET : CUSTOMER.C_CUSTKEY, COUNT( ORDERS.O_ORDERKEY )
2 - GROUP KEY : CUSTOMER.C_CUSTKEY
   RECORD COLUMN : COUNT( ORDERS.O_ORDERKEY )
   READ KEY COLUMN : CUSTOMER.C_CUSTKEY
   READ RECORD COLUMN : COUNT( ORDERS.O_ORDERKEY )
3 - JOINED COLUMN : CUSTOMER.C_CUSTKEY, ORDERS.O_ORDERKEY
4 - READ COLUMN : ORDERS.O_ORDERKEY, ORDERS.O_ORDERDATE
   PHYSICAL FILTER : ORDERS.O_ORDERDATE = DATE'1995-03-15'
5 - RECORD COLUMN : CUSTOMER.C_CUSTKEY
   READ COLUMN : CUSTOMER.C_CUSTKEY
6 - READ COLUMN : CUSTOMER.C_CUSTKEY, CUSTOMER.C_COMMENT
   LOGICAL FILTER : CUSTOMER.C_COMMENT LIKE '%special%requests%'
<<< end print plan
```

## Sort Merge Join

It sorts the intermediate results of an outer table and an inner table, then sequentially compares them, checks whether they satisfy the join condition and returns the join result.

When an index available exists in either an outer table or an inner table, then the table obtains the sorted intermediate results by using an index instead of using a sort instant.

One or more equi join conditions are required to perform a sort merge join.

Figure 25 Sort merge join

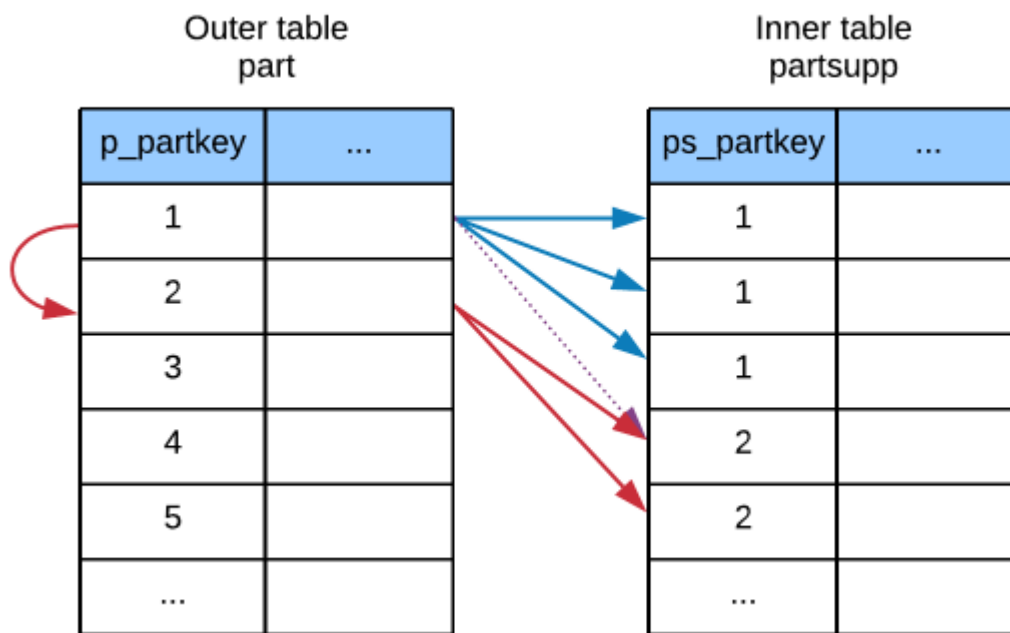

The following is an example of a sort merge join.

```

\EXPLAIN PLAN
SELECT p_name, p_brand, p_type
  FROM part, partsupp
 WHERE p_partkey = ps_partkey
        AND p_partkey < 10;
...
36 rows selected.
>>> start print plan
< Execution Plan >
=====
|  IDX  |  NODE DESCRIPTION  |
-----|-----|
|    0  |  SELECT STATEMENT  |
|    1  |  QUERY BLOCK ("QB_IDX_2")  |

```

```

| 2 |      MERGE JOIN (INNER JOIN) |
| 3 |      INDEX ACCESS ("PART", "PART_PK_INDEX") |
| 4 |      INDEX ACCESS ("PARTSUPP", "PARTSUPP_PARTKEY_FK") |
=====
1 - TARGET : PART.P_NAME, PART.P_BRAND, PART.P_TYPE
2 - JOINED COLUMN : PART.P_NAME, PART.P_BRAND, PART.P_TYPE
   ON FILTER (Equi) : PART.P_PARTKEY = PARTSUPP.PS_PARTKEY
3 - READ INDEX COLUMN : PART.P_PARTKEY
   READ TABLE COLUMN : PART.P_NAME, PART.P_BRAND, PART.P_TYPE
   MAX RANGE : PART.P_PARTKEY < 10
4 - READ INDEX COLUMN : PARTSUPP.PS_PARTKEY
   MAX RANGE : PARTSUPP.PS_PARTKEY < 10
<<< end print plan

```

## Hash Join

It creates a hash instant in an inner table, then returns the join result satisfying the join condition by using a hash.

One or more equi join conditions are required to perform a hash join.

Figure 26 Hash join

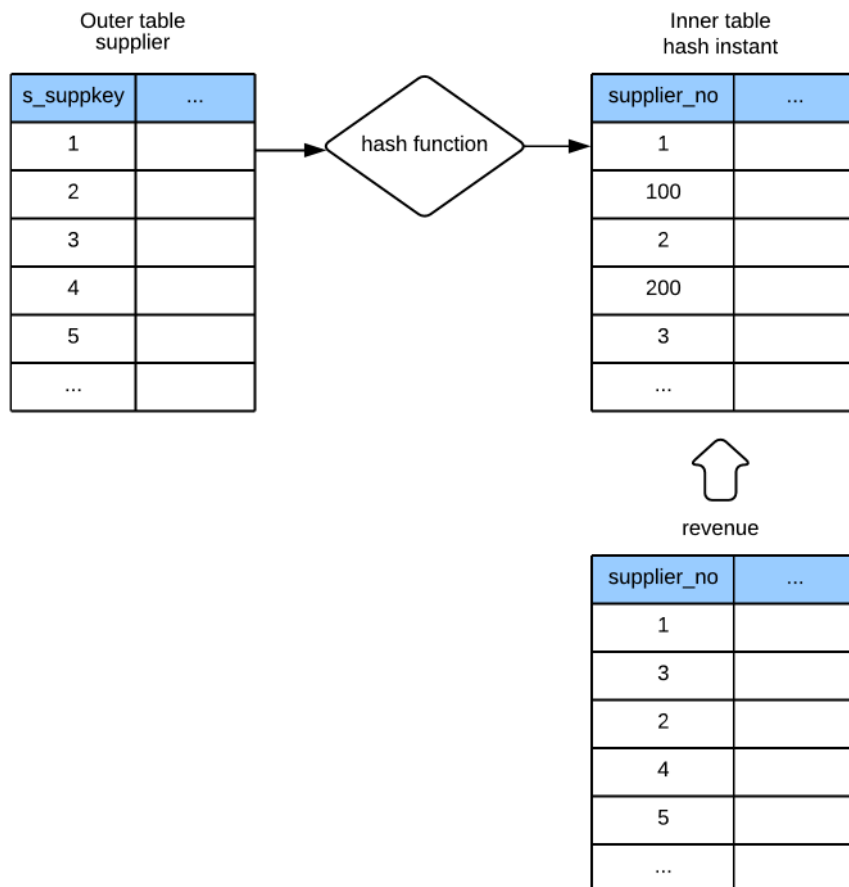



The following is an example of a hash join.

```

\EXPLAIN PLAN
SELECT s_suppkey,
       s_name,
       total_revenue
FROM supplier,
     (
       SELECT l_suppkey,
              ROUND( sum(l_extendedprice * (1 - l_discount)), 2)
              FROM lineitem
              WHERE l_shipdate >= date '1996-01-01'
                    AND l_shipdate < date '1996-01-01' + interval '3' month
              GROUP BY l_suppkey
     ) revenue(supplier_no, total_revenue)
WHERE
  s_suppkey = supplier_no;
...
10000 rows selected.
>>> start print plan
< Execution Plan >
=====
|  IDX  |  NODE DESCRIPTION                               |
-----|-----|
|   0   |  SELECT STATEMENT                               |
|   1   |    QUERY BLOCK ("QB_IDX_2")                     |
|   2   |      HASH JOIN (INNER JOIN)                     |
|   3   |        TABLE ACCESS ("SUPPLIER")               |
|   4   |        HASH JOIN INSTANT                        |
|   5   |          INLINE_VIEW ("REVENUE")                |
|   6   |            QUERY BLOCK ("QB_IDX_7")              |
|   7   |              GROUP HASH INSTANT                 |
|   8   |                TABLE ACCESS ("LINEITEM")       |
=====
1 - TARGET : SUPPLIER.S_SUPPKEY, SUPPLIER.S_NAME, REVENUE.$C1
2 - JOINED COLUMN : SUPPLIER.S_SUPPKEY, SUPPLIER.S_NAME, REVENUE.$C1
3 - READ COLUMN : SUPPLIER.S_SUPPKEY, SUPPLIER.S_NAME
4 - HASH KEY : REVENUE.L_SUPPKEY
  RECORD COLUMN : REVENUE.$C1
  READ KEY COLUMN : REVENUE.L_SUPPKEY, REVENUE.$C1
  HASH FILTER : REVENUE.L_SUPPKEY = SUPPLIER.S_SUPPKEY

```

```

5 - COLUMN : LINEITEM.L_SUPPKEY AS L_SUPPKEY, ROUND(SUM( LINEITEM.L_EXTENDEDPRI
- LINEITEM.L_DISCOUNT ) ),2) AS $C1
6 - TARGET : LINEITEM.L_SUPPKEY, ROUND(SUM( LINEITEM.L_EXTENDEDPRI * ( 1 -
LINEITEM.L_DISCOUNT ) ),2)
7 - GROUP KEY : LINEITEM.L_SUPPKEY
   RECORD COLUMN : SUM( LINEITEM.L_EXTENDEDPRI * ( 1 - LINEITEM.L_DISCOUNT ) )
   READ KEY COLUMN : LINEITEM.L_SUPPKEY
   READ RECORD COLUMN : SUM( LINEITEM.L_EXTENDEDPRI * ( 1 - LINEITEM.L_DISCOUNT ) )
8 - READ COLUMN : LINEITEM.L_SUPPKEY, LINEITEM.L_EXTENDEDPRI, LINEITEM.L_DISCOUNT,
LINEITEM.L_SHIPDATE
   PHYSICAL FILTER : LINEITEM.L_SHIPDATE < DATE'1996-01-01' + CAST( '3' AS
INTERVAL(MONTH) ) AND LINEITEM.L_SHIPDATE >= DATE'1996-01-01'
<<< end print plan

```

## Join Order

When joining three or more tables, the join order should be determined. The join order is determined in the way of joining two tables, then joining the intermediate result and the next table.

When there are three tables, then there are various join orders as follows.

Figure 27 Join order

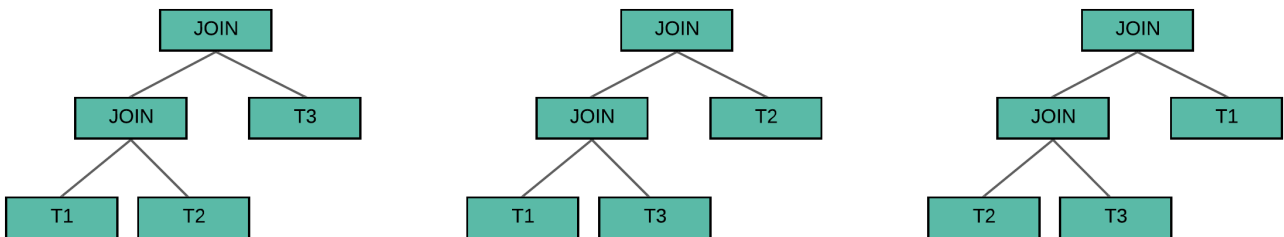

An enumerator creates sets of various execution plans according to join orders, join methods and access paths available, then it determines the join ordering by selecting the plan whose intermediate results and cost is low.

## Group By

It processes *group by*.

Generally, it processes *group by* by creating GROUP HASH INSTANT.

If the intermediate result is sorted for *group by key column* and ascends from the subordinate node, then it can be processed without accumulating separate hash instants.

The following is an example of processing *group by* by creating GROUP HASH INSTANT.

```

\EXPLAIN PLAN
  SELECT c_custkey, count(o_orderkey)
     FROM customer, orders
  WHERE c_custkey = o_custkey
       AND c_comment like '%special%requests%'
       AND o_orderdate = date '1995-03-15'
 GROUP BY c_custkey;
...
12 rows selected.
>>> start print plan
< Execution Plan >
=====
|  IDX  |  NODE DESCRIPTION  |
-----|-----|
|   0   |  SELECT STATEMENT  |
|   1   |    QUERY BLOCK ("QB_IDX_2")  |
|   2   |      GROUP HASH INSTANT  |
|   3   |        NESTED JOIN (INNER JOIN)  |
|   4   |          TABLE ACCESS ("CUSTOMER")  |
|   5   |          INDEX ACCESS ("ORDERS", "ORDERS_CUSTKEY_FK")  |
=====
1 - TARGET : CUSTOMER.C_CUSTKEY, COUNT( ORDERS.O_ORDERKEY )
2 - GROUP KEY : CUSTOMER.C_CUSTKEY
   RECORD COLUMN : COUNT( ORDERS.O_ORDERKEY )
   READ KEY COLUMN : CUSTOMER.C_CUSTKEY
   READ RECORD COLUMN : COUNT( ORDERS.O_ORDERKEY )
3 - JOINED COLUMN : CUSTOMER.C_CUSTKEY, ORDERS.O_ORDERKEY
4 - READ COLUMN : CUSTOMER.C_CUSTKEY, CUSTOMER.C_COMMENT
   LOGICAL FILTER : CUSTOMER.C_COMMENT LIKE '%special%requests%'
5 - READ INDEX COLUMN : ORDERS.O_CUSTKEY
   READ TABLE COLUMN : ORDERS.O_ORDERKEY, ORDERS.O_ORDERDATE
   MIN RANGE : ORDERS.O_CUSTKEY = {CUSTOMER.C_CUSTKEY}
   MAX RANGE : ORDERS.O_CUSTKEY = {CUSTOMER.C_CUSTKEY}
   PHYSICAL TABLE FILTER : ORDERS.O_ORDERDATE = DATE'1995-03-15'
<<< end print plan

```

The following is an example of processing *group by* by using the sorted intermediate results on the subordinate node.

```
\EXPLAIN PLAN
```

```
SELECT c_custkey, count(o_orderkey)
FROM customer, orders
WHERE c_custkey = o_custkey
AND c_custkey >= 10
AND c_custkey < 20
AND c_comment like '%special%requests%'
AND o_orderdate = date '1995-03-15'
```

```
GROUP BY c_custkey;
```

```
...
```

```
>>> start print plan
```

```
< Execution Plan >
```

```
=====
|  IDX  |  NODE DESCRIPTION  |
=====
|   0   |  SELECT STATEMENT  |
|   1   |  QUERY BLOCK ("QB_IDX_2")  |
|   2   |      GROUP          |
|   3   |      NESTED JOIN (INNER JOIN)  |
|   4   |      INDEX ACCESS ("CUSTOMER", "CUSTOMER_PK_INDEX")  |
|   5   |      INDEX ACCESS ("ORDERS", "ORDERS_CUSTKEY_FK")  |
=====
```

```
1 - TARGET : CUSTOMER.C_CUSTKEY, COUNT( ORDERS.O_ORDERKEY )
2 - GROUP KEY : CUSTOMER.C_CUSTKEY
   RECORD COLUMN : COUNT( ORDERS.O_ORDERKEY )
3 - JOINED COLUMN : CUSTOMER.C_CUSTKEY, ORDERS.O_ORDERKEY
4 - READ INDEX COLUMN : CUSTOMER.C_CUSTKEY
   READ TABLE COLUMN : CUSTOMER.C_COMMENT
   MIN RANGE : CUSTOMER.C_CUSTKEY >= 10
   MAX RANGE : CUSTOMER.C_CUSTKEY IS NOT NULL AND CUSTOMER.C_CUSTKEY < 20
   LOGICAL TABLE FILTER : CUSTOMER.C_COMMENT LIKE '%special%requests%'
5 - READ INDEX COLUMN : ORDERS.O_CUSTKEY
   READ TABLE COLUMN : ORDERS.O_ORDERKEY, ORDERS.O_ORDERDATE
   MIN RANGE : ORDERS.O_CUSTKEY = {CUSTOMER.C_CUSTKEY} AND ORDERS.O_CUSTKEY >= 10
   MAX RANGE : ORDERS.O_CUSTKEY = {CUSTOMER.C_CUSTKEY} AND ORDERS.O_CUSTKEY < 20
   LOGICAL KEY FILTER : ORDERS.O_CUSTKEY LIKE '%special%requests%'
   PHYSICAL TABLE FILTER : ORDERS.O_ORDERDATE = DATE'1995-03-15'
```

```
<<< end print plan
```

# Distinct

It processes distinct.

Generally, it processes distinct by creating GROUP HASH INSTANT.

If the intermediate result is sorted for distinct key column and ascends from the subordinate node, then it can be processed without accumulating separate hash instants.

The following is an example of processing distinct by creating GROUP HASH INSTANT.

```

\EXPLAIN PLAN
SELECT DISTINCT c_nationkey
  FROM customer
 WHERE c_comment like '%special%requests%'
;
...
>>> start print plan
< Execution Plan >
=====
|  IDX  |  NODE DESCRIPTION                                |
-----|-----|
|   0   |  SELECT STATEMENT                                |
|   1   |    QUERY BLOCK ("SQB_IDX_2")                     |
|   2   |      GROUP HASH INSTANT                         |
|   3   |        TABLE ACCESS ("CUSTOMER")                 |
=====
1 - TARGET : CUSTOMER.C_NATIONKEY
2 - GROUP KEY : CUSTOMER.C_NATIONKEY
  READ KEY COLUMN : CUSTOMER.C_NATIONKEY
3 - READ COLUMN : CUSTOMER.C_NATIONKEY, CUSTOMER.C_COMMENT
  LOGICAL FILTER : CUSTOMER.C_COMMENT LIKE '%special%requests%'
<<< end print plan

```

The following is an example of processing distinct by using the sorted intermediate results on the subordinate node.

```

\EXPLAIN PLAN
SELECT DISTINCT c_nationkey
  FROM customer
 WHERE c_nationkey >= 15
  AND c_nationkey < 20

```

```

        AND c_comment like '%special%requests%'
;
...
>>> start print plan
< Execution Plan >
=====
|  IDX  |  NODE DESCRIPTION                                |
-----|-----|
|    0  |  SELECT STATEMENT                                |
|    1  |    QUERY BLOCK ("QB_IDX_2")                      |
|    2  |      GROUP                                        |
|    3  |        INDEX ACCESS ("CUSTOMER", "CUSTOMER_NATIONKEY_FK") |
=====
1 - TARGET : CUSTOMER.C_NATIONKEY
2 - GROUP KEY : CUSTOMER.C_NATIONKEY
3 - READ INDEX COLUMN : CUSTOMER.C_NATIONKEY
   READ TABLE COLUMN : CUSTOMER.C_COMMENT
   MIN RANGE : CUSTOMER.C_NATIONKEY >= 15
   MAX RANGE : CUSTOMER.C_NATIONKEY IS NOT NULL AND CUSTOMER.C_NATIONKEY < 20
   LOGICAL TABLE FILTER : CUSTOMER.C_COMMENT LIKE '%special%requests%'
<<< end print plan

```

## Single Row Aggregation

It processes single row aggregation.

Generally, it performs aggregation by using a hash.

If it is a simple query acquiring MIN(), MAX(), then it may use an index.

The following is an example of processing single row aggregation by using a hash.

```

\EXPLAIN PLAN
SELECT count(o_orderkey)
  FROM customer, orders
 WHERE c_custkey = o_custkey
       AND c_comment like '%special%requests%';
COUNT(O_ORDERKEY)
-----
                33526
1 row selected.

```

```

>>> start print plan
< Execution Plan >
=====
|  IDX  |  NODE DESCRIPTION          |
-----|-----|
|   0   |  SELECT STATEMENT         |
|   1   |  QUERY BLOCK ("QB_IDX_2") |
|   2   |  AGGREGATION BY HASH      |
|   3   |  NESTED JOIN (INNER JOIN) |
|   4   |  TABLE ACCESS ("CUSTOMER") |
|   5   |  INDEX ACCESS ("ORDERS", "ORDERS_CUSTKEY_FK") |
=====

1 - TARGET : COUNT( ORDERS.O_ORDERKEY )
2 - AGGREGATION : COUNT( ORDERS.O_ORDERKEY )
3 - JOINED COLUMN : ORDERS.O_ORDERKEY
4 - READ COLUMN : CUSTOMER.C_CUSTKEY, CUSTOMER.C_COMMENT
   LOGICAL FILTER : CUSTOMER.C_COMMENT LIKE '%special%requests%'
5 - READ INDEX COLUMN : ORDERS.O_CUSTKEY
   READ TABLE COLUMN : ORDERS.O_ORDERKEY
   MIN RANGE : ORDERS.O_CUSTKEY = {CUSTOMER.C_CUSTKEY}
   MAX RANGE : ORDERS.O_CUSTKEY = {CUSTOMER.C_CUSTKEY}

<<< end print plan

```

The following is an example of processing single row aggregation by using an index.

```

\EXPLAIN PLAN SELECT MIN(c_custkey), MAX(c_custkey) FROM customer;
MIN(C_CUSTKEY) MAX(C_CUSTKEY)
-----
          1          150000
1 row selected.
>>> start print plan
< Execution Plan >
=====
|  IDX  |  NODE DESCRIPTION          |
-----|-----|
|   0   |  SELECT STATEMENT         |
|   1   |  QUERY BLOCK ("QB_IDX_2") |
|   2   |  INDEX ACCESS ("CUSTOMER", "CUSTOMER_PK_INDEX") |
=====

1 - TARGET : MIN( CUSTOMER.C_CUSTKEY ), MAX( CUSTOMER.C_CUSTKEY )
2 - READ INDEX COLUMN : CUSTOMER.C_CUSTKEY

```

```

                AGGREGATION : MIN( CUSTOMER.C_CUSTKEY ), MAX( CUSTOMER.C_CUSTKEY )
<<< end print plan

```

## Order By

It processes *order by*.

Generally, it processes order by by creating SORT INSTANT.

The following two methods are used to process *order by* of SORT INSTANT node.

- Sorting by using sort instant table
- Sorting by using limit sort (If *order by* is used together with *limit*, limit sort method is applied.)

If the intermediate result is sorted for order by key column and ascends from the subordinate node, then it can be processed without accumulating separate sort instants.

The following is an example of processing *order by* by creating SORT INSTANT.

```

\EXPLAIN PLAN
  SELECT c_nationkey
     FROM customer
     WHERE c_comment like '%special%requests%'
ORDER BY c_nationkey;
...
>>> start print plan
< Execution Plan >
=====
|  IDX  |  NODE DESCRIPTION                                |
-----|-----|
|   0   |  SELECT STATEMENT                                |
|   1   |    QUERY BLOCK ("$_QB_IDX_2")                    |
|   2   |      SORT INSTANT                               |
|   3   |        TABLE ACCESS ("CUSTOMER")                |
=====
1 - TARGET : CUSTOMER.C_NATIONKEY
2 - SORT KEY : "CUSTOMER.C_NATIONKEY ASC NULLS LAST"
   READ KEY COLUMN : CUSTOMER.C_NATIONKEY
3 - READ COLUMN : CUSTOMER.C_NATIONKEY, CUSTOMER.C_COMMENT
   LOGICAL FILTER : CUSTOMER.C_COMMENT LIKE '%special%requests%'
<<< end print plan

```



The following is an example of processing *order by* by using LIMIT SORT method. It is performed within SORT INSTANT node.

```

\EXPLAIN PLAN
  SELECT c_nationkey
  FROM customer
  WHERE c_comment like '%special%requests%'
ORDER BY c_nationkey
  LIMIT 3;
...
>>> start print plan
< Execution Plan >
=====
====
|  IDX  |  NODE DESCRIPTION          |
ROWS |
-----
|   0   |  SELECT STATEMENT          |
0 |
|   1   |  QUERY BLOCK ("QB_IDX_2")  |
0 |
|   2   |  SORT INSTANT              |
0 |
|   3   |  TABLE ACCESS ("CUSTOMER")|
0 |
=====
====
1 - TARGET : CUSTOMER.C_NATIONKEY
2 - LIMIT SORT
   SORT KEY : "CUSTOMER.C_NATIONKEY ASC NULLS LAST"
   READ KEY COLUMN : CUSTOMER.C_NATIONKEY
3 - READ COLUMN : CUSTOMER.C_NATIONKEY, CUSTOMER.C_COMMENT
   LOGICAL FILTER : CUSTOMER.C_COMMENT LIKE '%special%requests%'
<<< end print plan

```

The following is an example of processing *order by* by using the sorted intermediate results on the subordinate node. The *order by* processing is omitted.

```

>>> start print plan
\EXPLAIN PLAN

```

```
SELECT c_nationkey
FROM customer
WHERE c_nationkey >= 15
AND c_nationkey < 20
ORDER BY c_nationkey;
...
>>> start print plan
< Execution Plan >
=====
|  IDX  |  NODE DESCRIPTION  |
-----|-----|
|   0   |  SELECT STATEMENT  |
|   1   |  QUERY BLOCK ("SQB_IDX_2") |
|   2   |  INDEX ACCESS ("CUSTOMER", "CUSTOMER_NATIONKEY_FK") |
=====
1 - TARGET : CUSTOMER.C_NATIONKEY
2 - READ INDEX COLUMN : CUSTOMER.C_NATIONKEY
  READ TABLE COLUMN : CUSTOMER.C_COMMENT
  MIN RANGE : CUSTOMER.C_NATIONKEY >= 15
  MAX RANGE : CUSTOMER.C_NATIONKEY IS NOT NULL AND CUSTOMER.C_NATIONKEY < 20
<<< end print plan
```

## 15.4 Cluster

This chapter describes optimizing the cluster query in the cluster system.

For more information about the cluster system, refer to **GOLDILOCKS Cluster System Architecture**.

### Table Sharding Strategy

There are two types of table sharding strategies as follows.

- Cloned table
- Sharded table

The description and examples of table sharding strategies are as follows.

#### Cloned Table

All table data of every node in every group are stored same in the cloned table. Therefore it is appropriate for the table which is rarely updated and whose data is little.

The following is an example of creating a customer table with a cloned table.

Figure 28 Cloned table

```
CREATE TABLE customer  
( c_custkey INTEGER,  
  c_name   VARCHAR(25),  
  ...  
)  
CLONED  
AT CLUSTER GROUP g1, g2, g3;
```

c_custkey	c_name
1	SON
2	LEE
3	AHN
4	KIM
5	KIM
6	LEE



### Cluster system

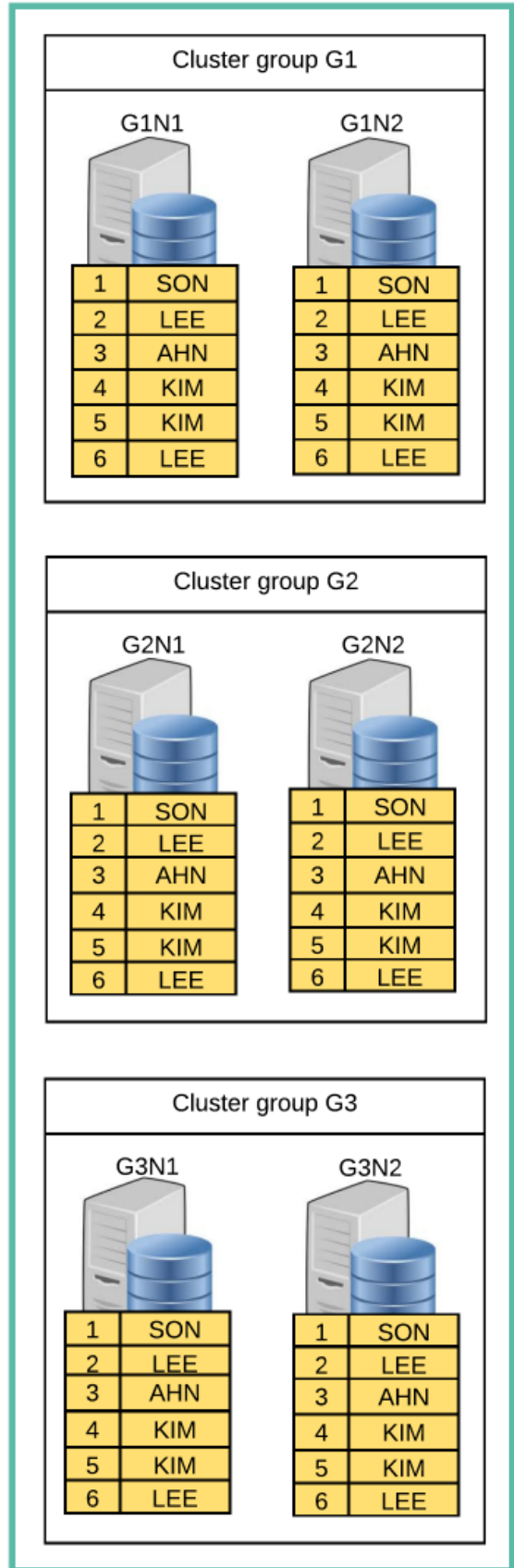

## Sharded Table

The data is divided in a group by a shard key, then stored. Nodes in a single group have the same data. Therefore, it is appropriate for the table which should be divided due to many data. There are three types of shards according to the sharding strategies as follows.

- Hash shard
- Range shard
- List shard

The following is an example of creating an order table by using hash shards.

Figure 29 Sharded table

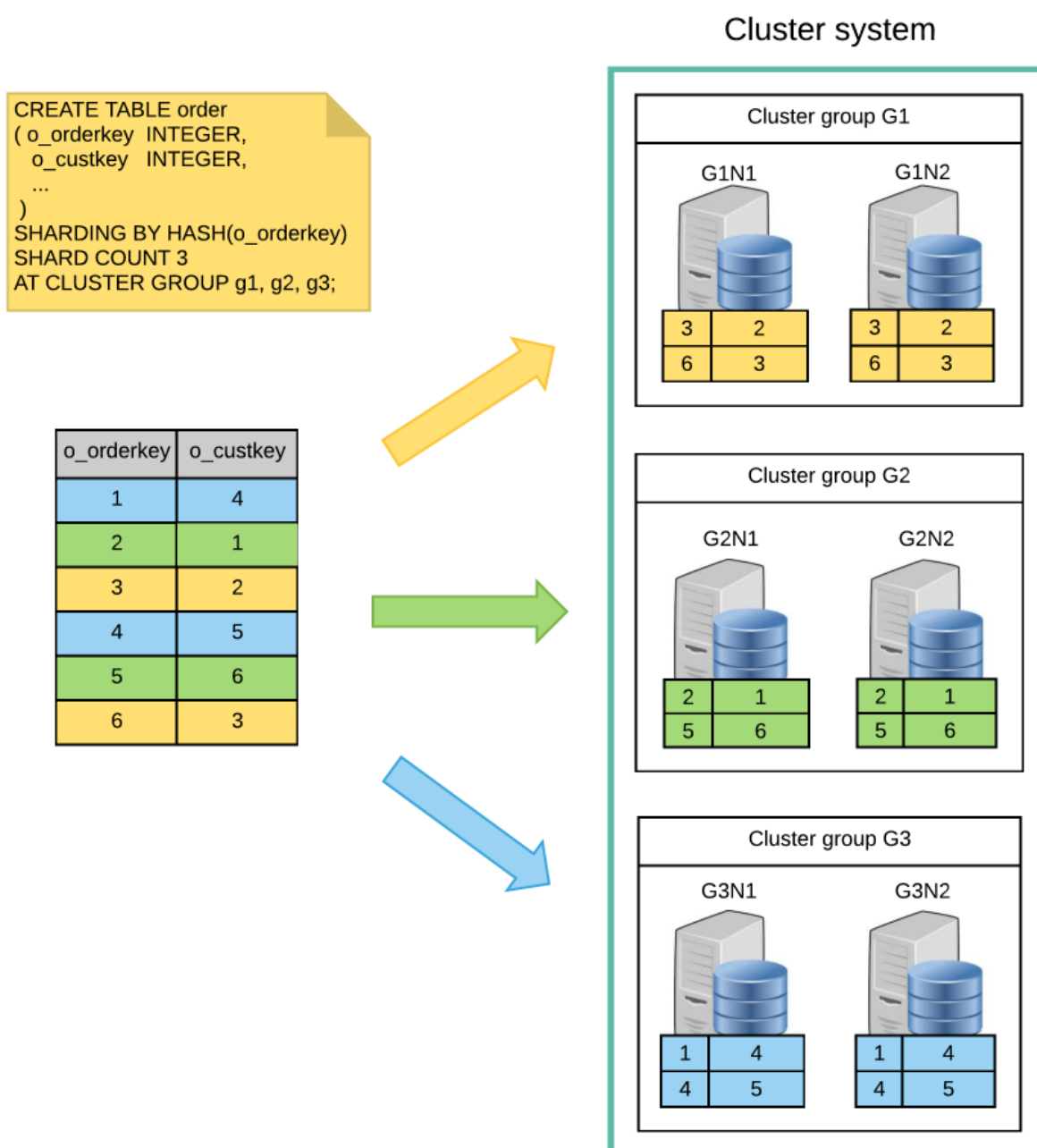

## Access

This paragraph describes the case of which a cluster query access a single table.

The following figure describes a local access and a remote access of when the current server is G1N1.

Figure 30 Cluster access

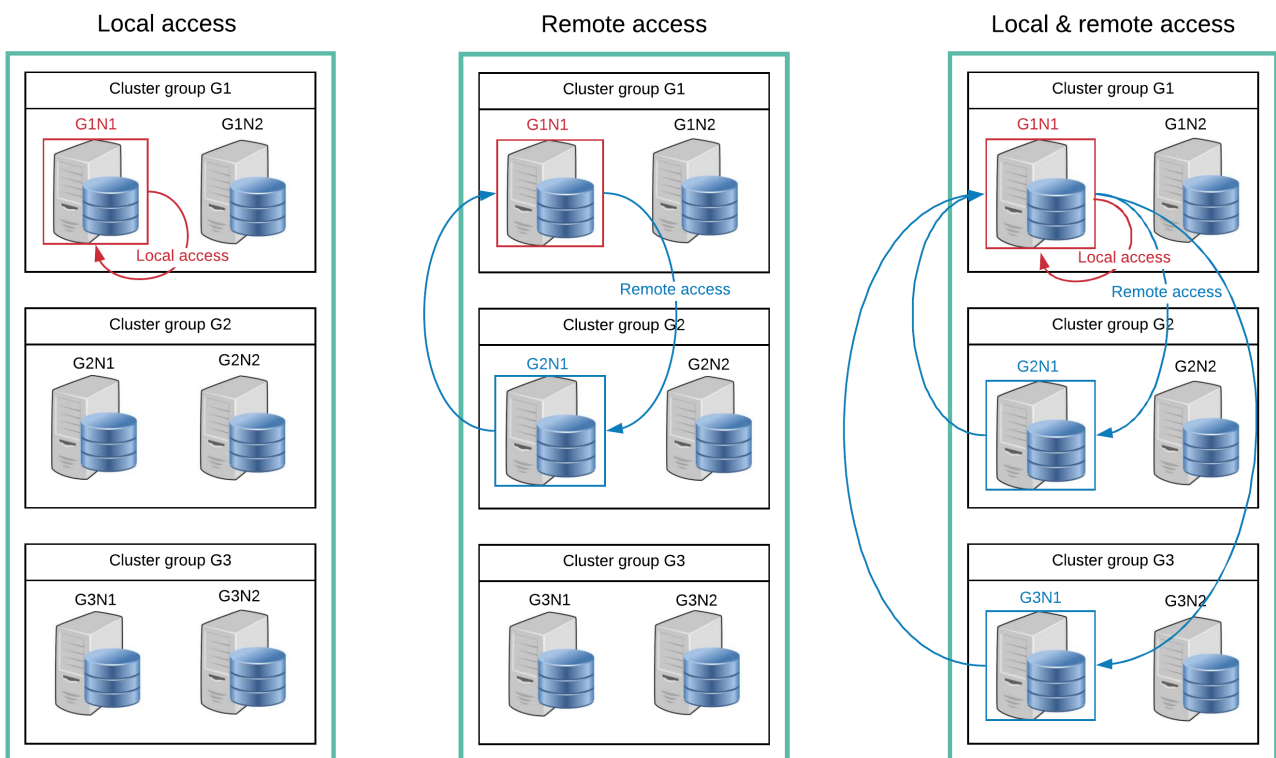

## Local Access

It performs the operation only on the current server in driver aspect.

If enquiring about the cloned table as follows, then it only needs to be performed in the current server because data in every node in all group are the same.

Figure 31 Local access (cloned table)

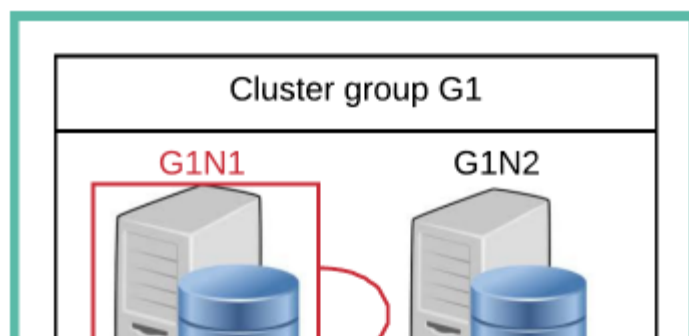

1	SON
2	LEE
3	AHN
4	KIM
5	KIM
6	LEE

1	SON
2	LEE
3	AHN
4	KIM
5	KIM
6	LEE

## Cluster group G2

G2N1



1	SON
2	LEE
3	AHN
4	KIM
5	KIM
6	LEE

G2N2



1	SON
2	LEE
3	AHN
4	KIM
5	KIM
6	LEE

## Cluster group G3

G3N1



1	SON
2	LEE
3	AHN
4	KIM
5	KIM
6	LEE

G3N2



1	SON
2	LEE
3	AHN
4	KIM
5	KIM
6	LEE

```

\EXPLAIN PLAN SELECT * FROM customer;
C_CUSTKEY C_NAME
-----
      1 SON
      2 LEE
      3 AHN
      4 KIM
      5 KIM
      6 LEE
6 rows selected.
>>> start print plan
< Execution Plan >
=====
|  IDX  |  NODE DESCRIPTION                                |  ROWS  |
=====
|  0  |  SELECT STATEMENT                                |    6  |
|  1  |  QUERY BLOCK ("SQB_IDX_2")                       |    6  |
|  2  |  TABLE ACCESS ("CUSTOMER")                      |    6  |
=====
      1 - TARGET : CUSTOMER.C_CUSTKEY, CUSTOMER.C_NAME
      2 - CLONED
          READ COLUMN : CUSTOMER.C_CUSTKEY, CUSTOMER.C_NAME
<<< end print plan

```

The data is divided in a group by a shard key, then stored in the sharded table. Therefore, it performs the local access when a filter for a shard key exists and the value can be performed only in the current server.



Figure 32 Local access (sharded table)

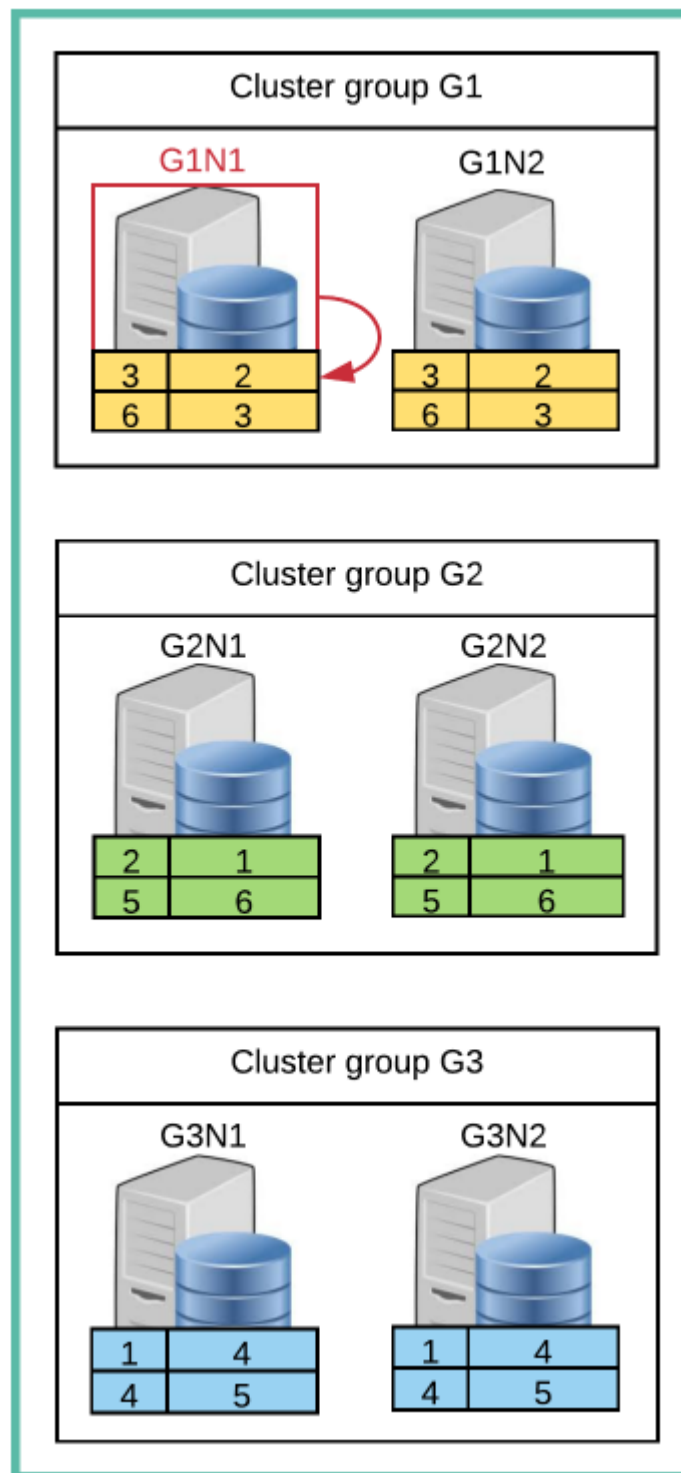

```
\EXPLAIN PLAN SELECT * FROM orders WHERE o_orderkey = 3;
```

```
O_ORDERKEY O_CUSTKEY
```

```
-----  
          3      2
```

```
1 row selected.
```

```
>>> start print plan
```

< Execution Plan >

```

=====
|  IDX  |  NODE DESCRIPTION                                |  ROWS  |
=====
|  0  |  SELECT STATEMENT                                |    1   |
|  1  |  QUERY BLOCK ("SQB_IDX_2")                       |    1   |
|  2  |  TABLE ACCESS ("ORDERS")                       |    1   |
=====
    
```

- 1 - TARGET : ORDERS.O\_ORDERKEY, ORDERS.O\_CUSTKEY
- 2 - HASH SHARD ( # 3 )
  - READ COLUMN : ORDERS.O\_ORDERKEY, ORDERS.O\_CUSTKEY
  - PHYSICAL FILTER : ORDERS.O\_ORDERKEY = 3

<<< end print plan

## Remote Access

The data is divided in a group by a shard key, then stored in the sharded table. Therefore, it can fetch the result by the remote access only to a specific server when a filter for a shard key exists.

Figure 33 Remote access

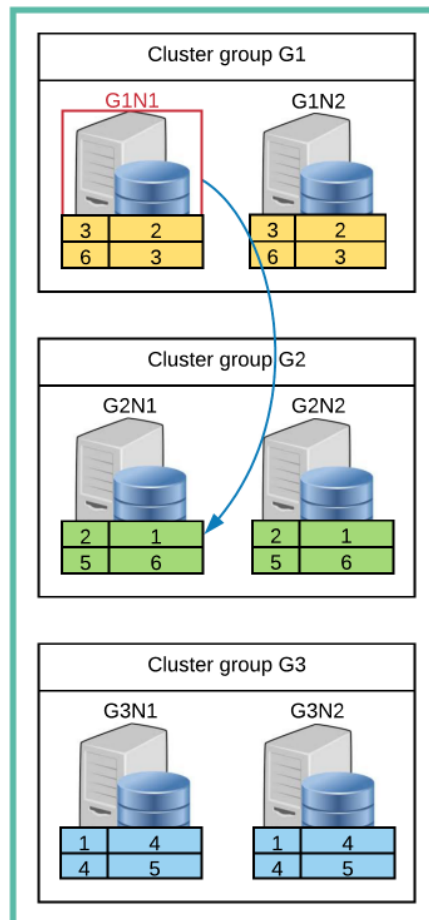

```

\EXPLAIN PLAN SELECT * FROM orders WHERE o_orderkey = 2;
O_ORDERKEY O_CUSTKEY
-----
          2      1
1 row selected.
>>> start print plan
< Execution Plan >
=====
|  IDX  |  NODE DESCRIPTION          |          ROWS |
-----
|  0  |  SELECT STATEMENT          |              1 |
|  1  |  QUERY BLOCK ("$_QB_IDX_2") |              1 |
|  2  |  PLAN BASED CLUSTER        | REMOTE ONLY 1 |
|  3  |  TABLE ACCESS ("ORDERS")  |              0 |
=====
1 - TARGET : ORDERS.O_ORDERKEY, ORDERS.O_CUSTKEY
2 - SQL : SELECT /*+ FULL( _A1 ) */
          "_A1"."O_ORDERKEY", "_A1"."O_CUSTKEY"
          FROM "PUBLIC"."ORDERS"@LOCAL AS "_A1"
          WHERE "_A1"."O_ORDERKEY" = :_V0
          TARGET DOMAIN : G2(G2N1,G2N2) 1 rows
3 - HASH SHARD ( # 3 )
   READ COLUMN : ORDERS.O_ORDERKEY, ORDERS.O_CUSTKEY
   PHYSICAL FILTER : ORDERS.O_ORDERKEY = 2
<<< end print plan

```

In the execution plan above, it fetched the result by remotely transferring SQL to G2.

If the sharded table does not have a filter for the shard key, then it should receive the result by transferring the query to each server.

Figure 34 Local & remote access

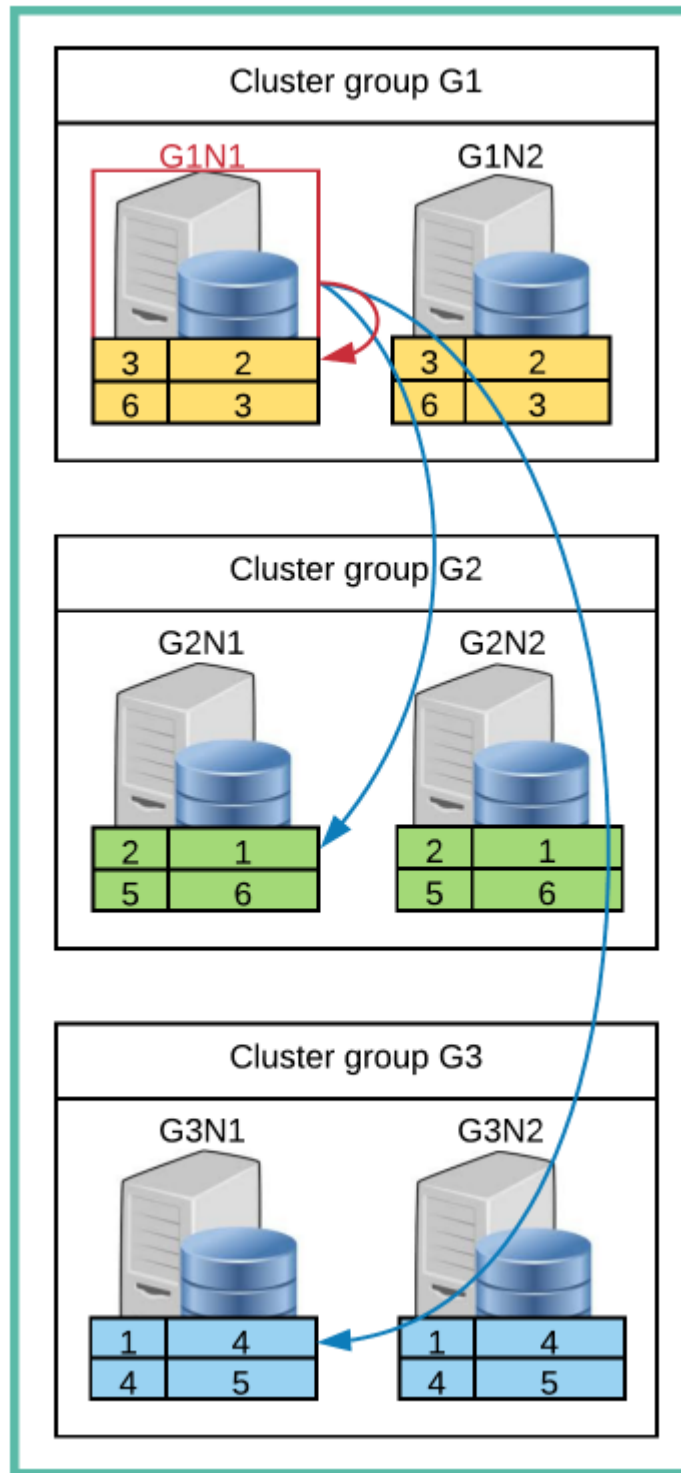

```

\EXPLAIN PLAN SELECT * FROM orders WHERE o_custkey = 1;
O_ORDERKEY O_CUSTKEY
-----
          2      1
1 row selected.
>>> start print plan
    
```

< Execution Plan >

```

=====
|  IDX  |  NODE DESCRIPTION                               |          ROWS |
=====
|   0   |  SELECT STATEMENT                               |              1 |
|   1   |  QUERY BLOCK ("SQB_IDX_2")                     |              1 |
|   2   |      PLAN BASED CLUSTER                         | LOCAL/REMOTE 1 |
|   3   |      TABLE ACCESS ("ORDERS")                  |              0 |
=====

1 - TARGET : ORDERS.O_ORDERKEY, ORDERS.O_CUSTKEY
2 - SQL : SELECT /*+ FULL( _A1 ) */
          "_A1"."O_ORDERKEY", "_A1"."O_CUSTKEY"
          FROM "PUBLIC"."ORDERS"@LOCAL AS "_A1"
          WHERE "_A1"."O_CUSTKEY" = :_V0
          TARGET DOMAIN : G1(G1N1,G1N2) 0 rows,
                          G2(G2N1,G2N2) 1 rows,
                          G3(G3N1,G3N2) 0 rows
3 - HASH SHARD ( # 3 )
   READ COLUMN : ORDERS.O_ORDERKEY, ORDERS.O_CUSTKEY
   PHYSICAL FILTER : ORDERS.O_CUSTKEY = 1
<<< end print plan

```

In the execution plan above, it fetched the result by remotely transferring SQL to G1, G2, G3.

## Join

### Local Join

It performs join in the current server. Local join types are various as follows.

The following is an example of joining *region* and *nation*. Both tables are cloned tables. All nodes in every group of the cloned tables has the same data. Therefore, it can perform the join only with data in G1N1 in the following example whose drive is G1N1.

```

\EXPLAIN PLAN
SELECT r_name, n_name
   FROM region, nation
  WHERE r_regionkey = n_regionkey;

```

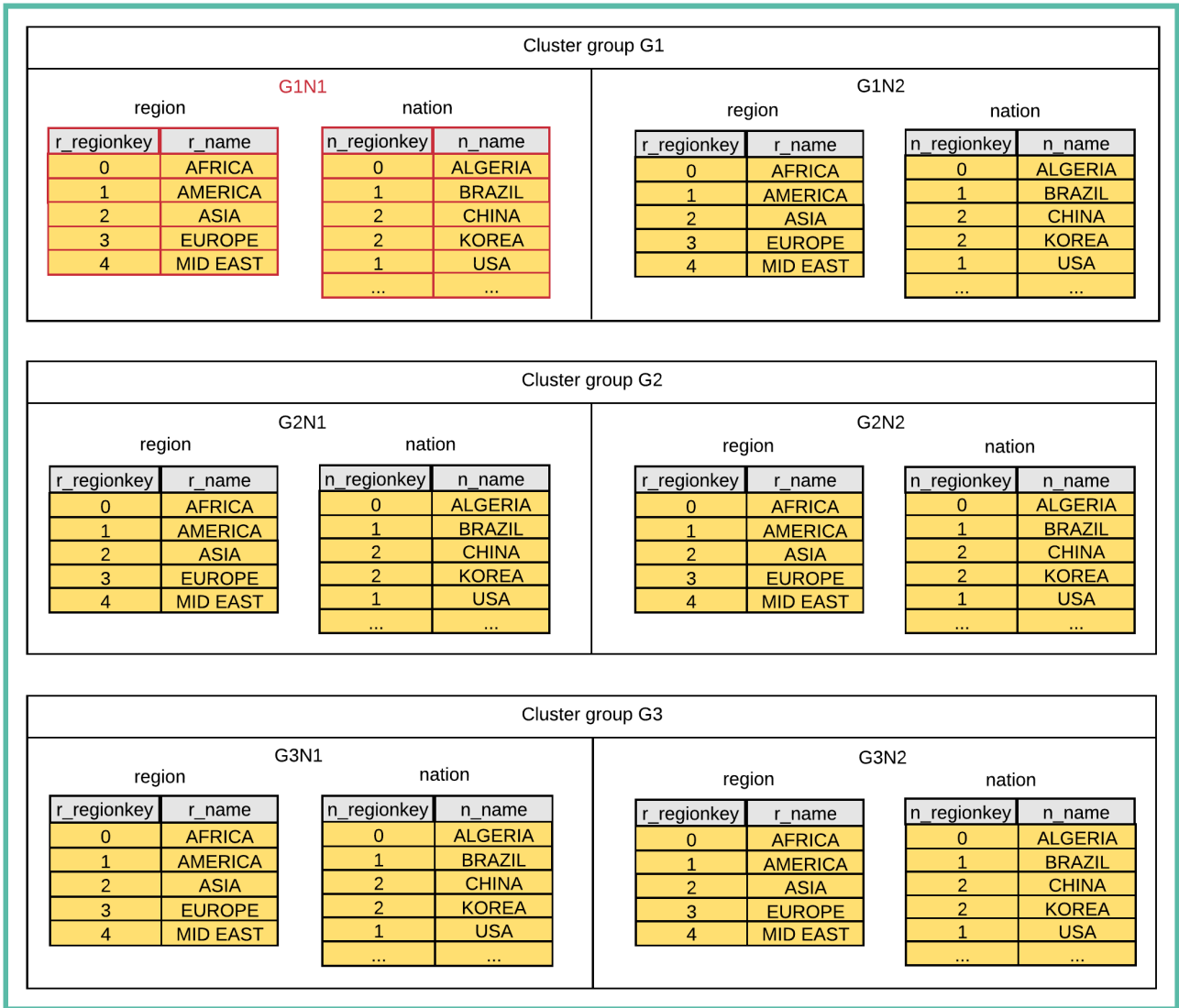

```
>>> start print plan
```

```
< Execution Plan >
```

```

=====
|  IDX  |  NODE DESCRIPTION  |
=====
|   0   |  SELECT STATEMENT  |
|   1   |  QUERY BLOCK ("$_QB_IDX_2") |
|   2   |    HASH JOIN (INNER JOIN) |
|   3   |      TABLE ACCESS ("NATION") |
|   4   |    HASH JOIN INSTANT |
|   5   |      TABLE ACCESS ("REGION") |
=====

1 - TARGET : REGION.R_NAME, NATION.N_NAME
2 - JOINED COLUMN : REGION.R_NAME, NATION.N_NAME
3 - CLONED

```

```

    READ COLUMN : NATION.N_NAME, NATION.N_REGIONKEY
4 - HASH KEY : REGION.R_REGIONKEY
    RECORD COLUMN : REGION.R_NAME
    READ KEY COLUMN : REGION.R_REGIONKEY, REGION.R_NAME
    HASH FILTER : REGION.R_REGIONKEY = NATION.N_REGIONKEY
    FETCH ONE ROW
5 - CLONED
    READ COLUMN : REGION.R_REGIONKEY, REGION.R_NAME
<<< end print plan

```

The following is an example of joining customer and orders. Customer is a cloned table and order is a sharded table. The data in the sharded table divided in a group by a shard key. Therefore, it can perform the local join when a filter for a shard key column exists and the data exists in the current server as the following example.

```

\EXPLAIN PLAN
SELECT c_custkey, COUNT(o_orderkey)
FROM customer, orders
WHERE c_custkey = o_custkey
AND o_orderkey = 3
GROUP BY c_custkey;

```

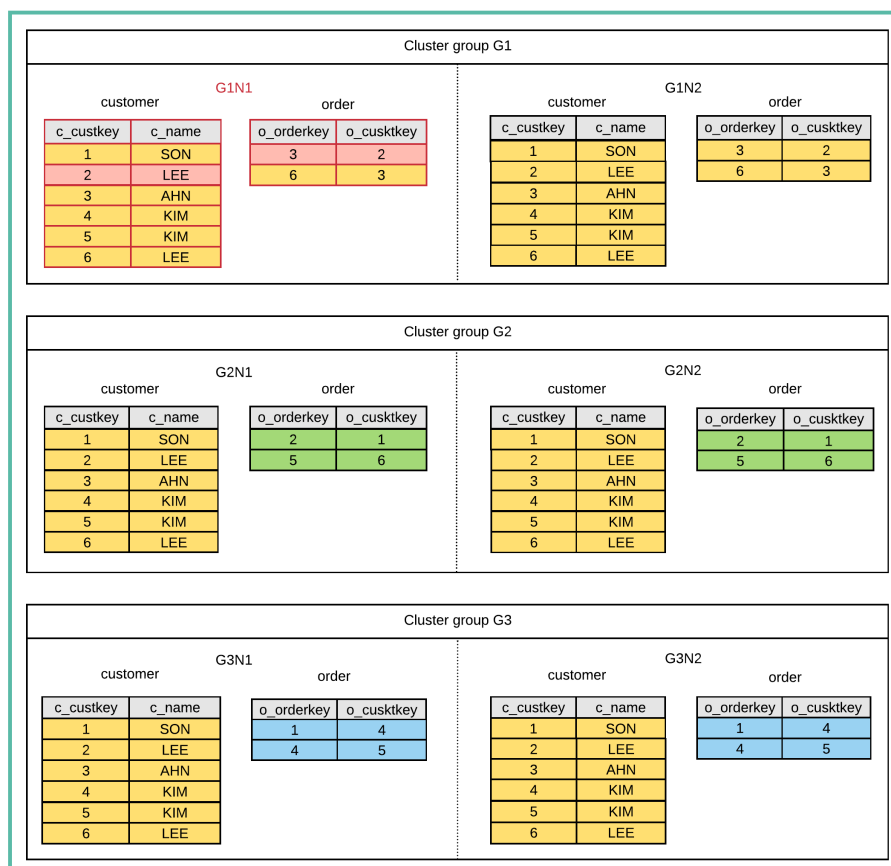

```

>>> start print plan
< Execution Plan >
=====
|  IDX  |  NODE DESCRIPTION  |
-----|-----|
|   0   |  SELECT STATEMENT  |
|   1   |    QUERY BLOCK ("SQB_IDX_2")  |
|   2   |      GROUP HASH INSTANT  |
|   3   |        NESTED JOIN (INNER JOIN)  |
|   4   |          INDEX ACCESS ("ORDERS", "ORDERS_PK_INDEX")  |
|   5   |          INDEX ACCESS ("CUSTOMER", "CUSTOMER_PK_INDEX")  |
=====

1 - TARGET : CUSTOMER.C_CUSTKEY, COUNT( ORDERS.O_ORDERKEY )
2 - GROUP KEY : CUSTOMER.C_CUSTKEY
   RECORD COLUMN : COUNT( ORDERS.O_ORDERKEY )
   READ KEY COLUMN : CUSTOMER.C_CUSTKEY
   READ RECORD COLUMN : COUNT( ORDERS.O_ORDERKEY )
3 - JOINED COLUMN : CUSTOMER.C_CUSTKEY, ORDERS.O_ORDERKEY
4 - HASH SHARD ( # 3 )
   READ INDEX COLUMN : ORDERS.O_ORDERKEY
   READ TABLE COLUMN : ORDERS.O_CUSTKEY
   MIN RANGE : ORDERS.O_ORDERKEY = 3
   MAX RANGE : ORDERS.O_ORDERKEY = 3
   FETCH ONE ROW
5 - CLONED
   READ INDEX COLUMN : CUSTOMER.C_CUSTKEY
   MIN RANGE : CUSTOMER.C_CUSTKEY = {ORDERS.O_CUSTKEY}
   MAX RANGE : CUSTOMER.C_CUSTKEY = {ORDERS.O_CUSTKEY}
   FETCH ONE ROW

<<< end print plan

```

The following is an example of joining customer and orders without a filter for a shard key column. In this case, the local join is available only after fetching all data in the sharded table.



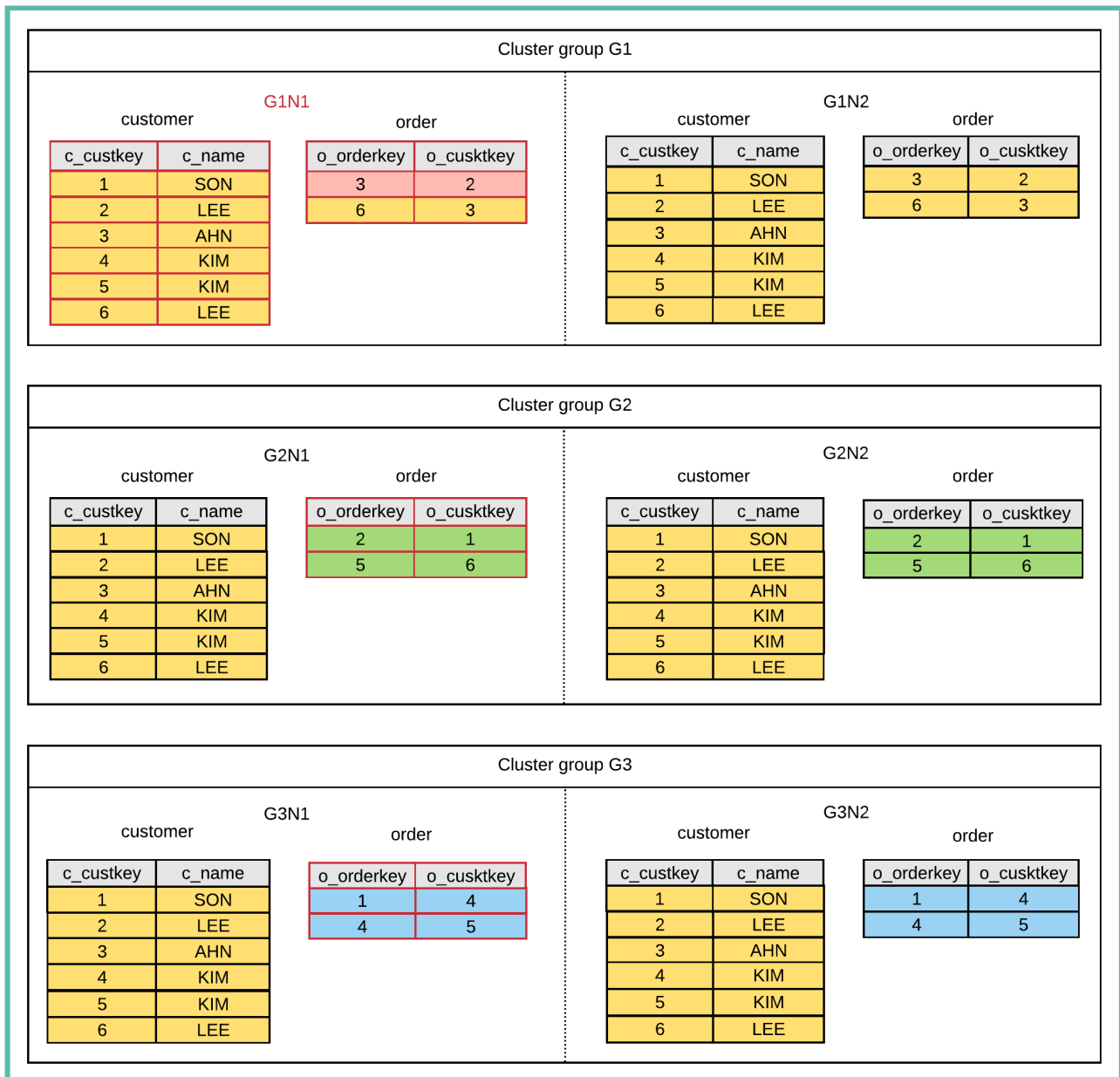

```
\EXPLAIN PLAN
```

```
SELECT /*+ LOCAL_JOIN(orders) */
      c_custkey, COUNT(o_orderkey)
FROM customer, orders
WHERE c_custkey = o_custkey
GROUP BY c_custkey;
```

```
< Execution Plan >
```

```
=====
|IDX|  NODE DESCRIPTION                                |          ROWS |
-----|-----|
| 0 |  SELECT STATEMENT                                |              6 |
```

```

| 1 | QUERY BLOCK ("$_QB_IDX_2") | 6 |
| 2 | HASH JOIN (INNER JOIN) | 6 |
| 3 | PLAN BASED CLUSTER | LOCAL/REMOTE 6 |
| 4 | INDEX ACCESS ("ORDERS", "ORDERS_PK_INDEX") | (6) 6 |
| 5 | HASH JOIN INSTANT | 6 |
| 6 | TABLE ACCESS ("CUSTOMER") | 6 |

```

```

=====
1 - TARGET : CUSTOMER.C_CUSTKEY, CUSTOMER.C_NAME, ORDERS.O_ORDERKEY
2 - JOINED COLUMN : CUSTOMER.C_CUSTKEY, CUSTOMER.C_NAME, ORDERS.O_ORDERKEY
3 - SQL : SELECT /*+ INDEX( _A1, "PUBLIC"."ORDERS_PK_INDEX" ) */
        "_A1"."O_ORDERKEY"
        FROM "PUBLIC"."ORDERS"@LOCAL AS "_A1"
        TARGET DOMAIN : G1(G1N1,G1N2) 2 rows,
                        G2(G2N1,G2N2) 2 rows,
                        G3(G3N1,G3N2) 2 rows
4 - HASH SHARD ( # 3 )
    READ INDEX COLUMN : ORDERS.O_ORDERKEY
5 - HASH KEY : CUSTOMER.C_CUSTKEY
    RECORD COLUMN : CUSTOMER.C_NAME
    READ KEY COLUMN : CUSTOMER.C_CUSTKEY, CUSTOMER.C_NAME
    HASH FILTER : CUSTOMER.C_CUSTKEY = ORDERS.O_ORDERKEY
    FETCH ONE ROW
6 - CLONED
    READ COLUMN : CUSTOMER.C_CUSTKEY, CUSTOMER.C_NAME
<<< end print plan

```

In the execution plan above, it fetched all data in order table by transferring SQL to G1, G2, G3.

## Remote Join

It performs join in each server.

Join processing in each server has a parallel processing effect. Also, when results are decreased a lot by the join, then bringing the result by performing join in the server reduces the network cost.

This chapter describes various forms of remote.

## Joining Cloned Table and Sharded Table

This chapter describes about joining a cloned table and a sharded table.

The following is an example of joining customer and orders. Customer is a cloned table, order is a sharded table, and the data is distributed as follows.

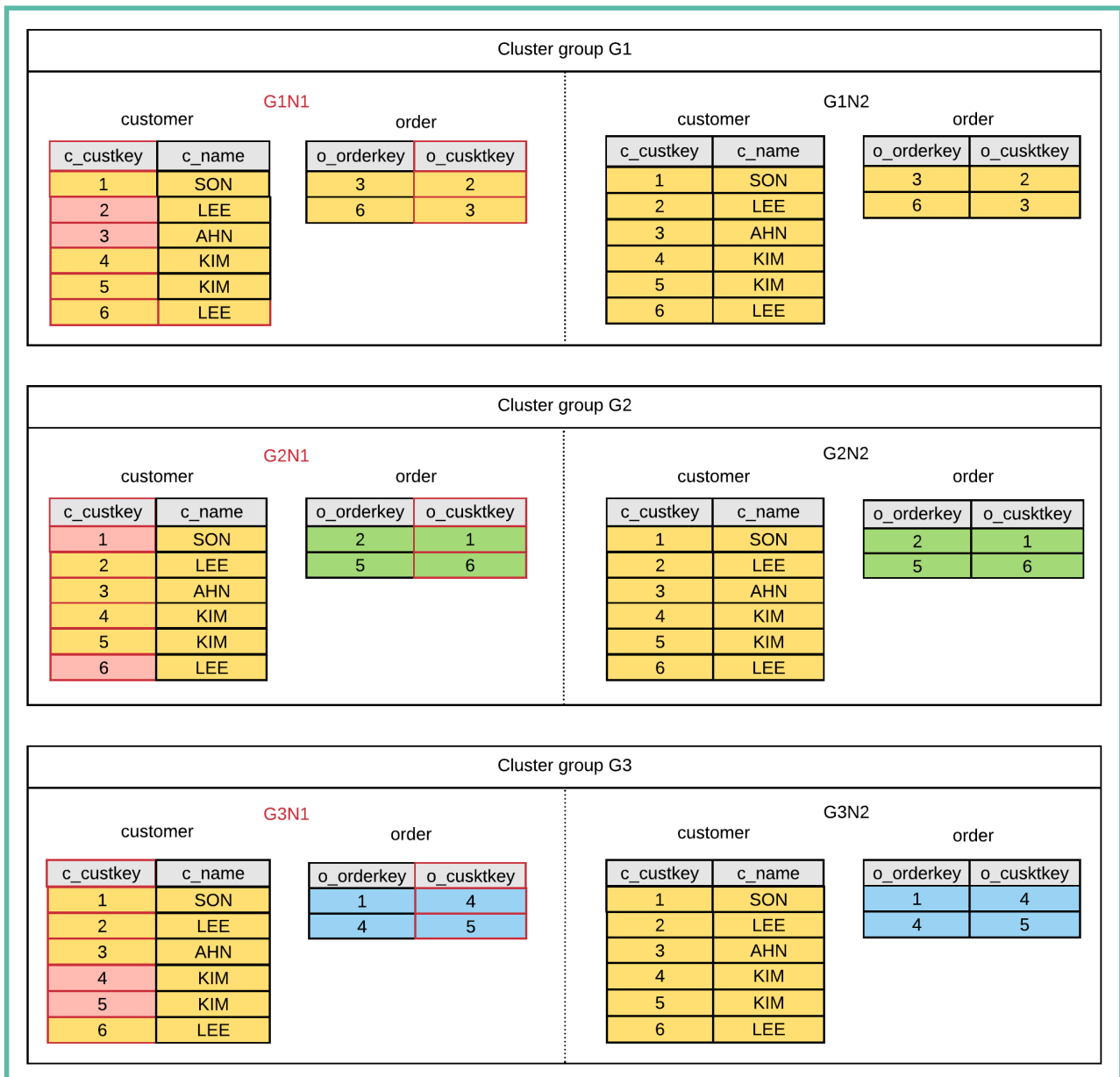

```
\EXPLAIN PLAN
```

```
SELECT /*+ REMOTE_JOIN(orders) */
```

```
    c_custkey, COUNT(o_orderkey)
```

```
FROM customer, orders
```

```
WHERE c_custkey = o_cusktkey
```

```
GROUP BY c_custkey;
```

```
>>> start print plan
```

```
< Execution Plan >
```

```
=====
|IDX|  NODE DESCRIPTION                                |          ROWS |
-----|-----|
| 0 |  SELECT STATEMENT                                |              6 |
```

```

| 1 | QUERY BLOCK ("$_QB_IDX_2") | 6 |
| 2 | PLAN BASED CLUSTER | LOCAL/REMOTE 6 |
| 3 | HASH JOIN (INNER JOIN) | 6 |
| 4 | TABLE ACCESS ("ORDERS") | 6 |
| 5 | HASH JOIN INSTANT | 6 |
| 6 | TABLE ACCESS ("CUSTOMER") | 6 |
=====
1 - TARGET : CUSTOMER.C_CUSTKEY, CUSTOMER.C_NAME, ORDERS.O_ORDERKEY
2 - SQL : SELECT /*+ KEEP_JOINED_TABLE USE_HASH_IN( _A1, 10 )
          FULL( _A2 )
          FULL( _A1 ) */
          "_A1"."C_CUSTKEY", "_A1"."C_NAME", "_A2"."O_ORDERKEY"
FROM ("PUBLIC"."ORDERS"@LOCAL AS "_A2"
      INNER JOIN
      "PUBLIC"."CUSTOMER"@LOCAL AS "_A1"
      ON "_A1"."C_CUSTKEY" = "_A2"."O_ORDERKEY") ALIAS "_A3"
TARGET DOMAIN : G1(G1N1,G1N2) 2 rows,
                G2(G2N1,G2N2) 2 rows,
                G3(G3N1,G3N2) 2 rows
3 - JOINED COLUMN : CUSTOMER.C_CUSTKEY, CUSTOMER.C_NAME, ORDERS.O_ORDERKEY
4 - HASH SHARD ( # 3 )
   READ COLUMN : ORDERS.O_ORDERKEY
5 - HASH KEY : CUSTOMER.C_CUSTKEY
   RECORD COLUMN : CUSTOMER.C_NAME
   READ KEY COLUMN : CUSTOMER.C_CUSTKEY, CUSTOMER.C_NAME
   HASH FILTER : CUSTOMER.C_CUSTKEY = ORDERS.O_ORDERKEY
6 - CLONED
   READ COLUMN : CUSTOMER.C_CUSTKEY, CUSTOMER.C_NAME
<<< end print plan

```

In the execution plan above, it performed join in each server and fetched the result by transferring SQL to G1, G2, G3.

## Joining Sharded Table and Sharded Table

The remote join is available when satisfying the following conditions.

- A shard key join condition exists. (e.g. t1.shardKeyCol = t2.shardKeyCol )
- Shard strategies are same.
  - Joining hash sharded table and hash sharded table
  - Joining range shard and range shard
  - Joining list shard and list shard

- Shard counts are same.
- Shard key column types are same.
- The number of shard key columns are same.

The following is an example of joining orders and lineitem. Both tables are hash sharded tables, and a shard key join condition exists. They are sharded for orderkey of the same standard, so the join is performed in each server.

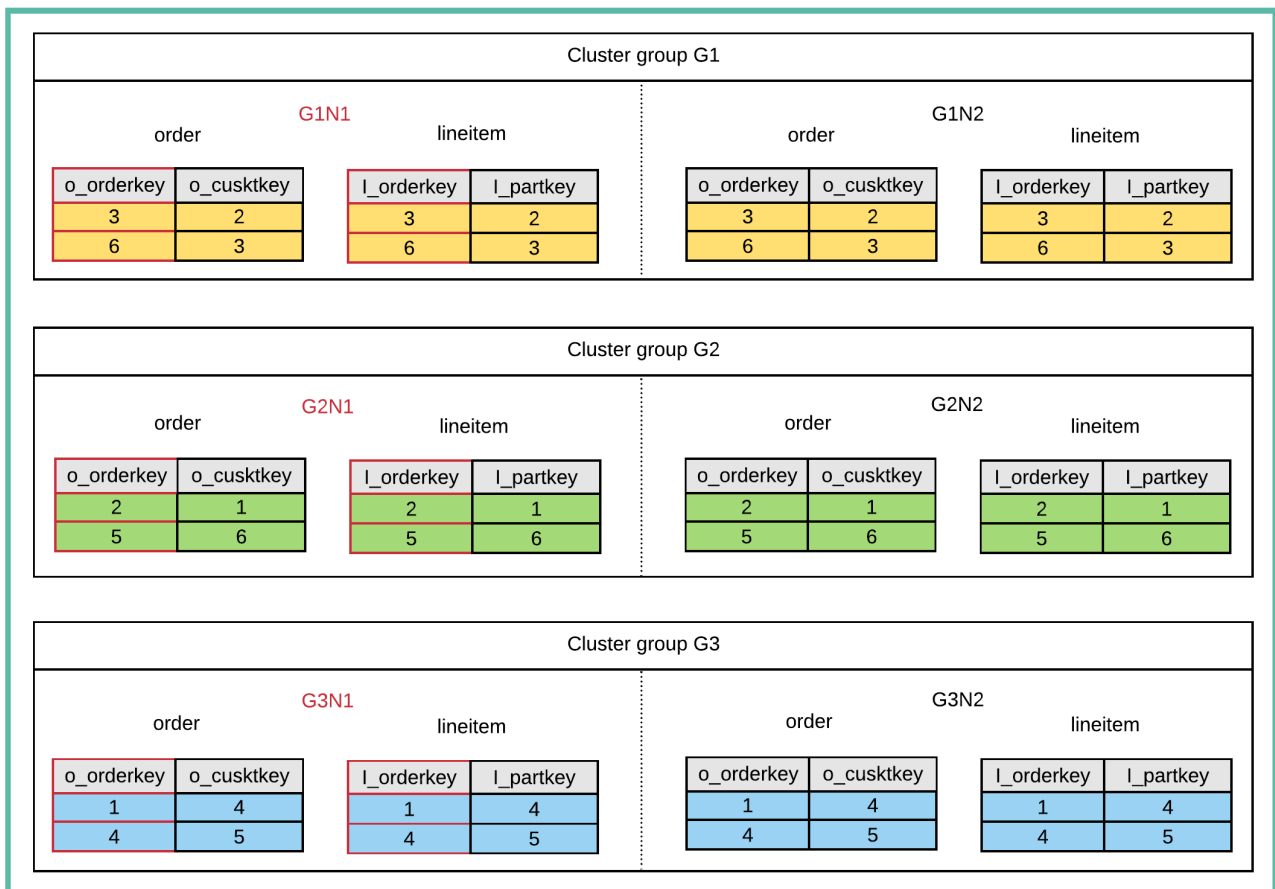

```
\EXPLAIN PLAN
SELECT o_orderkey, l_partkey
FROM orders, lineitem
WHERE o_orderkey = l_orderkey;
```

```
>>> start print plan
```

```
< Execution Plan >
```

```
=====
|IDX|  NODE DESCRIPTION                               |          ROWS |
-----|-----|
| 0 |  SELECT STATEMENT                               |             6 |
| 1 |  QUERY BLOCK ("$$QB_IDX_2")                     |             6 |
=====
```

```

| 2 |          PLAN BASED CLUSTER          | LOCAL/REMOTE 6 | |
| 3 |          HASH JOIN (INNER JOIN)      |                | 2 |
| 4 |          INDEX ACCESS ("ORDERS", "ORDERS_PK_INDEX") | (2)           | 2 |
| 5 |          HASH JOIN INSTANT           |                | 2 |
| 6 |          TABLE ACCESS ("LINEITEM")  |                | 2 |

```

```

=====
1 - TARGET : ORDERS.O_ORDERKEY, LINEITEM.L_PARTKEY
2 - SQL : SELECT /*+ KEEP_JOINED_TABLE USE_HASH_IN( _A1, 10 )
          INDEX( _A2, "PUBLIC"."ORDERS_PK_INDEX" )
          FULL( _A1 ) */
          "_A2"."O_ORDERKEY", "_A1"."L_PARTKEY"
FROM ( "PUBLIC"."ORDERS"@LOCAL AS "_A2"
      INNER JOIN
      "PUBLIC"."LINEITEM"@LOCAL AS "_A1"
      ON "_A1"."L_ORDERKEY" = "_A2"."O_ORDERKEY") ALIAS "_A3"
TARGET DOMAIN : G1(G1N1,G1N2) 2 rows,
                G2(G2N1,G2N2) 2 rows,
                G3(G3N1,G3N2) 2 rows
3 - JOINED COLUMN : ORDERS.O_ORDERKEY, LINEITEM.L_PARTKEY
4 - HASH SHARD ( # 3 )
   READ INDEX COLUMN : ORDERS.O_ORDERKEY
5 - HASH KEY : LINEITEM.L_ORDERKEY
   RECORD COLUMN : LINEITEM.L_PARTKEY
   READ KEY COLUMN : LINEITEM.L_ORDERKEY, LINEITEM.L_PARTKEY
   HASH FILTER : LINEITEM.L_ORDERKEY = ORDERS.O_ORDERKEY
6 - HASH SHARD ( # 3 )
   READ COLUMN : LINEITEM.L_ORDERKEY, LINEITEM.L_PARTKEY

```

```
<<< end print plan
```

In the execution plan above, it performed join in each server and fetched the result by transferring join SQL to each server.

The following is an example of joining part and lineitem. Both tables are hash sharded tables. However, a shard key join condition does not exist.

Both part and lineitem are hash sharded tables. However, data in part is sharded based on p\_partkey because the shard key of part is p\_partkey. On the other hand, data in lineitem is sharded based on l\_orderkey because the shard key of lineitem is l\_orderkey.

```

\EXPLAIN PLAN
SELECT /*+ REMOTE_JOIN(lineitem) */
       l_orderkey, p_partkey

```

```

FROM part, lineitem
WHERE p_partkey = l_partkey;

```

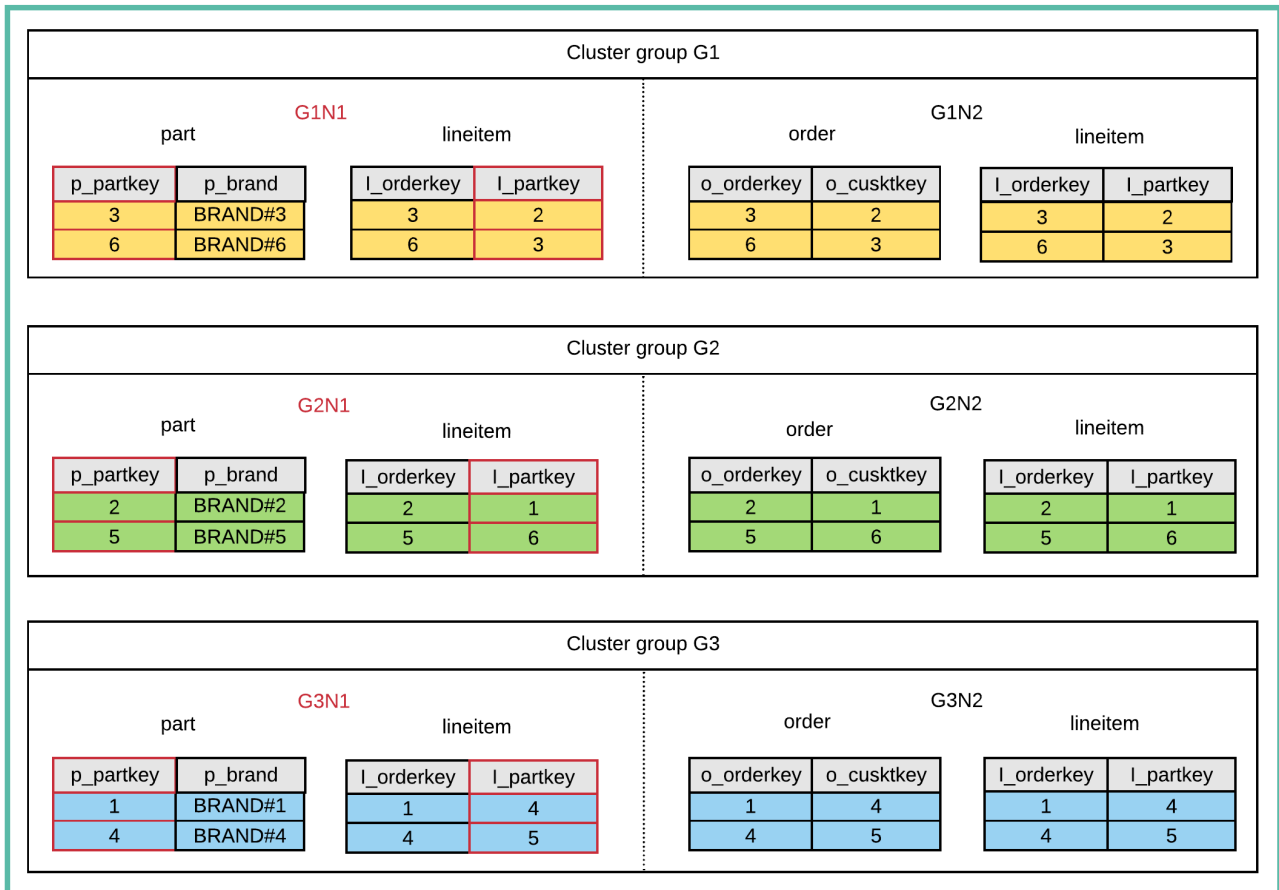

For the query above to perform the remote join, it should fetch all data of lineitem, then shard them with l\_partkey and transfer to G1, G2, G3. In this case, a puller and a pusher take this role.

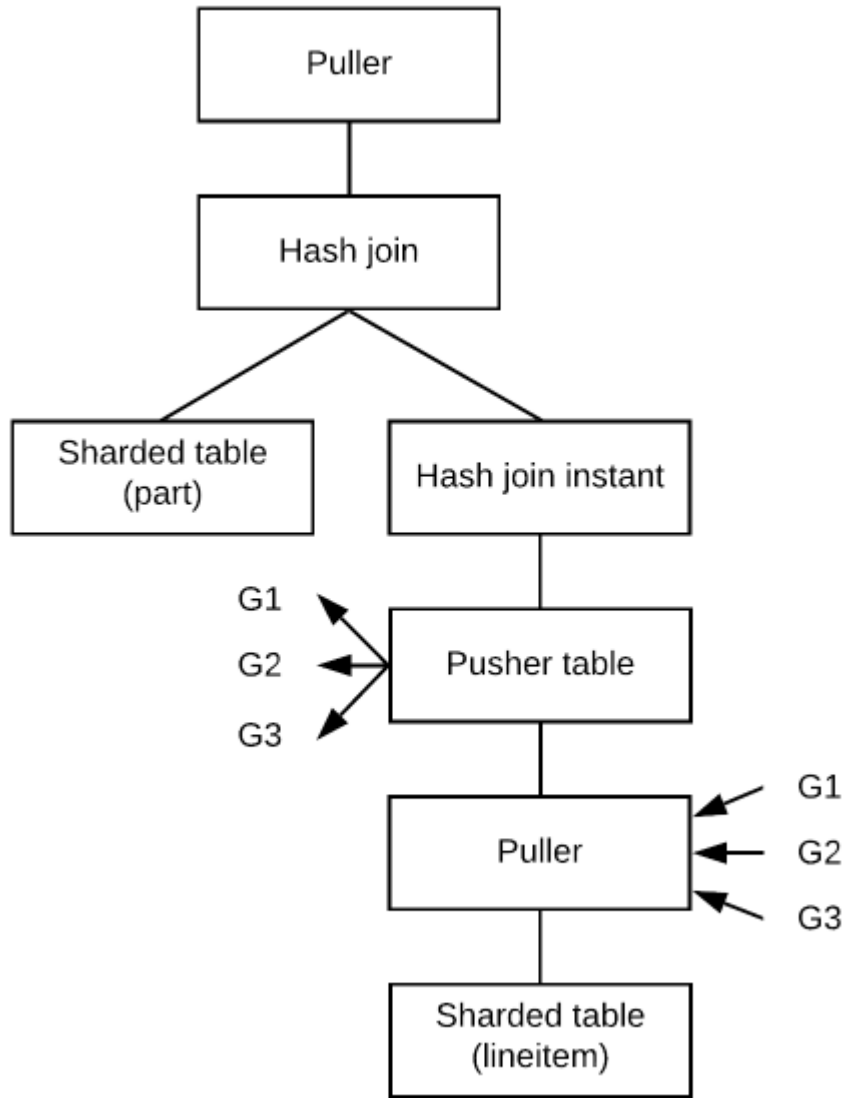

- **Cluster Puller:** It fetches data by transferring the SQL query to each server.
- **Cluster Pusher:** It transfers data to each server.

In the figure above, a puller fetches all data from lineitem. Then, l\_partkey makes a pusher table which is a shard key, and transfers data to G1, G2, G3. And it performs a remote join of part table and pusher table in G1, G2 and G3.

The execution plan is as follows.

```

>>> start print plan
< Execution Plan >
=====
|IDX|  NODE DESCRIPTION                                     |  ROWS  |
=====
| 0 |  SELECT STATEMENT                                     |      6 |
    
```



```

| 1 | QUERY BLOCK ("$_QB_IDX_2") | 6 |
| 2 | SINGLE CLUSTER | LOCAL/REMOTE 6 |
| 3 | CLUSTER PUSHER ("$_NI_7") | 6 |
| 4 | PLAN BASED CLUSTER | LOCAL/REMOTE 6 |
| 5 | TABLE ACCESS ("LINEITEM") | 2 |
| 6 | SELECT STATEMENT | 2 |
| 7 | QUERY BLOCK ("$_QB_IDX_2") | 2 |
| 8 | HASH JOIN (INNER JOIN) | 2 |
| 9 | INDEX ACCESS ("PART" AS _A2, "PART_PK_INDEX") | (2) 2 |
| 10 | HASH JOIN INSTANT | 2 |
| 11 | PUSHER TABLE ACCESS ("$_NI_7" AS _A1) | 2 |

```

```

=====
1 - TARGET : $_NI_7.L_ORDERKEY, PART.P_PARTKEY
2 - SQL : SELECT /*+ KEEP_JOINED_TABLE USE_HASH_IN( _A1, 10 )
          INDEX( _A2, "PUBLIC"."PART_PK_INDEX" )
          FULL( _A1 ) */
          "_A1"."L_ORDERKEY", "_A2"."P_PARTKEY"
FROM ( "PUBLIC"."PART"@LOCAL AS "_A2"
      INNER JOIN
      "SESSION_SCHEMA"."$_NI_7"@LOCAL AS "_A1"
      ON "_A1"."L_PARTKEY" = "_A2"."P_PARTKEY" ) ALIAS "_A3"
TARGET DOMAIN : G1(G1N1,G1N2) 2 rows,
                G2(G2N1,G2N2) 2 rows,
                G3(G3N1,G3N2) 2 rows
3 - SQL : DECLARE INSTANT TABLE "SESSION_SCHEMA"."$_NI_7"
          ( "L_PARTKEY" NUMBER(10, 0), "L_ORDERKEY" NUMBER(10, 0) )
COLUMN : LINEITEM.L_PARTKEY AS L_PARTKEY,
        LINEITEM.L_ORDERKEY AS L_ORDERKEY
SHARDED : LINEITEM.L_PARTKEY
TARGET DOMAIN : G1(G1N1,G1N2) 2 rows,
                G2(G2N1,G2N2) 2 rows,
                G3(G3N1,G3N2) 2 rows
4 - SQL : SELECT /*+ FULL( _A1 ) */
          "_A1"."L_ORDERKEY", "_A1"."L_PARTKEY"
FROM "PUBLIC"."LINEITEM"@LOCAL AS "_A1"
TARGET DOMAIN : G1(G1N1,G1N2) 2 rows,
                G2(G2N1,G2N2) 2 rows,
                G3(G3N1,G3N2) 2 rows
5 - HASH SHARD ( # 3 )
READ COLUMN : LINEITEM.L_ORDERKEY, LINEITEM.L_PARTKEY
7 - TARGET : _A1.L_ORDERKEY, _A2.P_PARTKEY

```

```

8 - JOINED COLUMN : _A1.L_ORDERKEY, _A2.P_PARTKEY
9 - HASH SHARD ( # 3 )
  READ INDEX COLUMN : _A2.P_PARTKEY
10 - HASH KEY : _A1.L_PARTKEY
  RECORD COLUMN : _A1.L_ORDERKEY
  READ KEY COLUMN : _A1.L_PARTKEY, _A1.L_ORDERKEY
  HASH FILTER : _A1.L_PARTKEY = _A2.P_PARTKEY
11 - READ COLUMN : _A1.L_PARTKEY, _A1.L_ORDERKEY
<<< end print plan

```

In the execution plan above, (l\_orderkey, l\_partkey) is fetched by transferring SQL to G1, G2, G3 in 4. And (l\_partkey, l\_orderkey) value fetched from 4 is stored in a pusher table whose shard key is (l\_partkey, l\_orderkey) in 3. This pusher table is sharded by l\_partkey, then transferred and temporarily stored in G1, G2, G3.

A remote join is performed as joining part table and pusher table.

## Group By

### Local Group By

It performs *group by* in current server.

If it is group by for a cloned table, then every node in all groups have the same data, so just perform *group by* in the current server.

```

\EXPLAIN PLAN
  SELECT c_nationkey, COUNT(c_custkey)
  FROM customer
GROUP BY c_nationkey;
>>> start print plan
< Execution Plan >
=====
|  IDX  |  NODE DESCRIPTION  |
=====
|   0   |  SELECT STATEMENT  |
|   1   |    QUERY BLOCK ("QB_IDX_2")  |
|   2   |      GROUP HASH INSTANT  |
|   3   |    TABLE ACCESS ("CUSTOMER")  |
=====
1 - TARGET : CUSTOMER.C_NATIONKEY, COUNT( CUSTOMER.C_CUSTKEY )
2 - GROUP KEY : CUSTOMER.C_NATIONKEY

```

```

        RECORD COLUMN : COUNT( CUSTOMER.C_CUSTKEY )
        READ KEY COLUMN : CUSTOMER.C_NATIONKEY
        READ RECORD COLUMN : COUNT( CUSTOMER.C_CUSTKEY )
3 - CLONED
        READ COLUMN : CUSTOMER.C_CUSTKEY, CUSTOMER.C_NATIONKEY
<<< end print plan

```

## Remote Group By

It performs *group by* in each server.

*Group by* processing in each server has a parallel processing effect. Also, generally *group by* reduces results, so it reduces the network cost to bring the data.

```

\EXPLAIN PLAN
SELECT c_custkey, COUNT(o_orderkey)
  FROM customer, orders
 WHERE c_custkey = o_custkey
GROUP BY c_custkey;
>>> start print plan
< Execution Plan >
=====
|IDX|  NODE DESCRIPTION                               |          ROWS |
=====
| 0 | SELECT STATEMENT                                   |              6 |
| 1 |   QUERY BLOCK ("$_QB_IDX_2")                       |              6 |
| 2 |     SINGLE CLUSTER                                 | LOCAL/REMOTE 6 |
| 3 |       SELECT STATEMENT                             |              2 |
| 4 |         QUERY BLOCK ("$_QB_IDX_2")                 |              2 |
| 5 |           GROUP HASH INSTANT                       |              2 |
| 6 |             HASH JOIN (INNER JOIN)                 |              2 |
| 7 |               TABLE ACCESS ("CUSTOMER" AS _A2)   |              6 |
| 8 |                 HASH JOIN INSTANT                  |              2 |
| 9 |                   TABLE ACCESS ("ORDERS" AS _A1) |              2 |
=====
1 - TARGET : CUSTOMER.C_CUSTKEY, COUNT( ORDERS.O_ORDERKEY )
2 - SQL : SELECT /*+ USE_GROUP_HASH(10)
           KEEP_JOINED_TABLE USE_HASH_IN( _A1, 100 )
           FULL( _A2 ) FULL( _A1 )
           */
           "_A2"."C_CUSTKEY", COUNT( "_A1"."O_ORDERKEY" )
FROM ( "PUBLIC"."CUSTOMER"@LOCAL AS "_A2"

```

```

INNER JOIN
  "PUBLIC"."ORDERS"@LOCAL AS "_A1"
  ON "_A1"."O_CUSTKEY" = "_A2"."C_CUSTKEY") ALIAS "_A3"
  GROUP BY "_A2"."C_CUSTKEY"
TARGET DOMAIN : G1(G1N1,G1N2) 2 rows,
                G2(G2N1,G2N2) 2 rows,
                G3(G3N1,G3N2) 2 rows

RE-GROUPING
  GROUP KEY : CUSTOMER.C_CUSTKEY
  AGGREGATION : SUM( COUNT( ORDERS.O_ORDERKEY ) )
4 - TARGET : _A2.C_CUSTKEY, COUNT( _A1.O_ORDERKEY )
5 - GROUP KEY : _A2.C_CUSTKEY
  RECORD COLUMN : COUNT( _A1.O_ORDERKEY )
  READ KEY COLUMN : _A2.C_CUSTKEY
  READ RECORD COLUMN : COUNT( _A1.O_ORDERKEY )
6 - JOINED COLUMN : _A2.C_CUSTKEY, _A1.O_ORDERKEY
7 - CLONED
  READ COLUMN : _A2.C_CUSTKEY
8 - HASH KEY : _A1.O_CUSTKEY
  RECORD COLUMN : _A1.O_ORDERKEY
  READ KEY COLUMN : _A1.O_CUSTKEY, _A1.O_ORDERKEY
  HASH FILTER : _A1.O_CUSTKEY = _A2.C_CUSTKEY
9 - HASH SHARD ( # 3 )
  READ COLUMN : _A1.O_ORDERKEY, _A1.O_CUSTKEY

<<< end print plan

```

## Distinct

### Local Distinct

It performs distinct in current server.

The following is an example of using distinct in customer which is a cloned table. Every node in all groups in a cloned table has the same data, so just perform distinct in the current server.

```

\EXPLAIN PLAN
SELECT DISTINCT c_nationkey
  FROM customer;
>>> start print plan
< Execution Plan >

```

```

=====
|  IDX  |  NODE DESCRIPTION                                |
-----
|   0   |  SELECT STATEMENT                                |
|   1   |    QUERY BLOCK ("$_QB_IDX_2")                    |
|   2   |      GROUP                                        |
|   3   |        INDEX ACCESS ("CUSTOMER", "CUSTOMER_NATIONKEY_FK") |
=====
1 - TARGET : CUSTOMER.C_NATIONKEY
2 - GROUP KEY : CUSTOMER.C_NATIONKEY
3 - CLONED
   READ INDEX COLUMN : CUSTOMER.C_NATIONKEY
<<< end print plan

```

The following is an example of using distinct in orders which is a sharded table. The data in a sharded table is sharded based in a shard key, so the data from all groups should be fetched when it is needed to locally perform distinct.

```

\EXPLAIN PLAN
SELECT /*+ LOCAL_DISTINCT */
      DISTINCT o_orderstatus
      FROM orders
      WHERE o_orderdate = date '1995-03-15';
>>> start print plan
< Execution Plan >
=====
|IDX|  NODE DESCRIPTION                                |          ROWS |
-----
| 0 |  SELECT STATEMENT                                |              3 |
| 1 |    QUERY BLOCK ("$_QB_IDX_2")                    |              3 |
| 2 |      GROUP HASH INSTANT                          |              3 |
| 3 |        PLAN BASED CLUSTER                        | LOCAL/REMOTE 603 |
| 4 |          TABLE ACCESS ("ORDERS")                |              221 |
=====
1 - TARGET : ORDERS.O_ORDERSTATUS
2 - GROUP KEY : ORDERS.O_ORDERSTATUS
   READ KEY COLUMN : ORDERS.O_ORDERSTATUS
3 - SQL : SELECT /*+ FULL( _A1 ) */
      "_A1"."O_ORDERSTATUS"
      FROM "PUBLIC"."ORDERS"@LOCAL AS "_A1"
      WHERE "_A1"."O_ORDERDATE" = :_V0

```

```

          TARGET DOMAIN : G1(G1N1,G1N2) 221 rows,
                        G2(G2N1,G2N2) 184 rows,
                        G3(G3N1,G3N2) 198 rows
4 - HASH SHARD ( # 3 )
    READ COLUMN : ORDERS.O_ORDERSTATUS, ORDERS.O_ORDERDATE
    PHYSICAL FILTER : ORDERS.O_ORDERDATE = DATE '1995-03-15'
<<< end print plan

```

In the execution plan above, GROUP HASH INSTANT for distinct was performed after fetching data satisfying the condition from G1, G2, G3.

## Remote Distinct

It performs distinct in each server.

Distinct processing in each server has a parallel processing effect. Also, generally distinct reduces results, so it reduces the network cost to bring the data.

```

\EXPLAIN PLAN
SELECT DISTINCT o_orderstatus
  FROM orders
 WHERE o_orderdate = date '1995-03-15';
>>> start print plan
< Execution Plan >
=====
|IDX|  NODE DESCRIPTION                               |          ROWS |
-----|-----|
| 0 |  SELECT STATEMENT                                   |              3 |
| 1 |    QUERY BLOCK ("$_QB_IDX_2")                       |              3 |
| 2 |      SINGLE CLUSTER                                | LOCAL/REMOTE 3 |
| 3 |        SELECT STATEMENT                             |              3 |
| 4 |          QUERY BLOCK ("$_QB_IDX_2")                 |              3 |
| 5 |            GROUP HASH INSTANT                       |              3 |
| 6 |              TABLE ACCESS ("ORDERS" AS _A1)       |            221 |
=====
1 - TARGET : ORDERS.O_ORDERSTATUS
2 - SQL : SELECT /*+ USE_DISTINCT_HASH(3) FULL( _A1 ) */
        DISTINCT "_A1"."O_ORDERSTATUS"
        FROM "PUBLIC"."ORDERS"@LOCAL AS "_A1"
        WHERE "_A1"."O_ORDERDATE" = :_V0
    TARGET DOMAIN : G1(G1N1,G1N2) 3 rows,
                  G2(G2N1,G2N2) 3 rows,

```

```

                                G3(G3N1,G3N2) 3 rows
                                RE-GROUPING
                                GROUP KEY : ORDERS.O_ORDERSTATUS
4 - TARGET : _A1.O_ORDERSTATUS
5 - GROUP KEY : _A1.O_ORDERSTATUS
  READ KEY COLUMN : _A1.O_ORDERSTATUS
6 - HASH SHARD ( # 3 )
  READ COLUMN : _A1.O_ORDERSTATUS, _A1.O_ORDERDATE
  PHYSICAL FILTER : _A1.O_ORDERDATE = :_V0
<<< end print plan

```

In the execution plan above, It fetched results of performing distinct from G1, G2, G3, then performed distinct again with RE-GROUPING. Though RE-GROUPING is performed, the results are decreased a lot so the network cost is reduced and it is efficient.

## Order By

### Local Order By

It performs *order by* in the current server.

The following is an example of using *order by* in customer which is a cloned table. Every node in all groups in a cloned table has the same data, so just perform *order by* in the current server.

```

\EXPLAIN PLAN
  SELECT c_nationkey, COUNT(c_custkey)
  FROM customer
 GROUP BY c_nationkey
 ORDER BY c_nationkey;
>>> start print plan
< Execution Plan >

=====
|  IDX  |  NODE DESCRIPTION                               |  ROWS  |
=====
|  0  |  SELECT STATEMENT                               |        |
|  1  |  QUERY BLOCK ("$_QB_IDX_2")                     |        |
|  2  |  SORT INSTANT                                    |        |
|  3  |  GROUP HASH INSTANT                             |        |
|  4  |  TABLE ACCESS ("CUSTOMER")                     | 150000 |
=====
1 - TARGET : CUSTOMER.C_NATIONKEY, COUNT( CUSTOMER.C_CUSTKEY )

```

```

2 - SORT KEY : "CUSTOMER.C_NATIONKEY ASC NULLS LAST"
   RECORD COLUMN : COUNT( CUSTOMER.C_CUSTKEY )
   READ KEY COLUMN : CUSTOMER.C_NATIONKEY
   READ RECORD COLUMN : COUNT( CUSTOMER.C_CUSTKEY )
3 - GROUP KEY : CUSTOMER.C_NATIONKEY
   RECORD COLUMN : COUNT( CUSTOMER.C_CUSTKEY )
   READ KEY COLUMN : CUSTOMER.C_NATIONKEY
   READ RECORD COLUMN : COUNT( CUSTOMER.C_CUSTKEY )
4 - CLONED
   READ COLUMN : CUSTOMER.C_CUSTKEY, CUSTOMER.C_NATIONKEY

```

```
<<< end print plan
```

The following is an example of using *order by* in orders which is a sharded table. The data in a sharded table is sharded based in a shard key, so the data from all groups should be fetched when it is needed to locally perform *order by*.

```

\EXPLAIN PLAN
SELECT /*+ LOCAL_ORDER */ o_orderdate, o_shippriority
FROM orders
WHERE o_orderdate >= date '1993-07-01'
AND o_orderdate < date '1993-07-01' + interval '1' month
ORDER BY o_orderdate;

```

```
>>> start print plan
```

```
< Execution Plan >
```

```

=====
|IDX|  NODE DESCRIPTION                               |          ROWS |
-----|-----|
| 0 |  SELECT STATEMENT                               |          19319 |
| 1 |    QUERY BLOCK ("$_QB_IDX_2")                  |          19319 |
| 2 |      SORT INSTANT                              |          19319 |
| 3 |        PLAN BASED CLUSTER                      | LOCAL/REMOTE 19319 |
| 4 |          TABLE ACCESS ("ORDERS")              |           6453 |
=====

```

```

1 - TARGET : ORDERS.O_ORDERDATE, ORDERS.O_SHIPRIORITY
2 - SORT KEY : "ORDERS.O_ORDERDATE ASC NULLS LAST"
   RECORD COLUMN : ORDERS.O_SHIPRIORITY
   READ KEY COLUMN : ORDERS.O_ORDERDATE
   READ RECORD COLUMN : ORDERS.O_SHIPRIORITY
3 - SQL : SELECT /*+ FULL( _A1 ) */
          "_A1"."O_ORDERDATE", "_A1"."O_SHIPRIORITY"
FROM "PUBLIC"."ORDERS"@LOCAL AS "_A1"

```



```

        WHERE "_A1"."O_ORDERDATE" < :_V0
        AND "_A1"."O_ORDERDATE" >= :_V1
    TARGET DOMAIN : G1(G1N1,G1N2) 6453 rows,
                  G2(G2N1,G2N2) 6450 rows,
                  G3(G3N1,G3N2) 6416 rows
4 - HASH SHARD ( # 3 )
    READ COLUMN : ORDERS.O_ORDERDATE, ORDERS.O_SHIPPRIORITY
    PHYSICAL FILTER : ORDERS.O_ORDERDATE < DATE'1993-07-01' + CAST( '1' AS
INTERVAL(MONTH) ) AND ORDERS.O_ORDERDATE >= DATE'1993-07-01'
<<< end print plan

```

In the execution plan above, It fetched data satisfying the condition from G1, G2, G3, then performed SORT INSTANT.

## Remote Order By

It performs *order by* in each server.

*Order by* processing in each server has a parallel processing effect. Also, if results are sorted on the subordinate node and ascends to the superordinate node, then each server does not need to separately process *order by* and the driver just merges and sorts the result received from each server.

The following is an example of remote order by. orders is a sharded table.

```

\EXPLAIN PLAN
  SELECT o_custkey, o_orderstatus
  FROM orders
  WHERE o_custkey > 0 AND o_custkey < 10
ORDER BY o_custkey;
>>> start print plan
< Execution Plan >
=====
|IDX| NODE DESCRIPTION                                     | ROWS |
=====
| 0 | SELECT STATEMENT                                       | 66   |
| 1 |  QUERY BLOCK ("$_QB_IDX_2")                             | 66   |
| 2 |    MULTIPLE CLUSTER                                   | LOCAL/REMOTE 66 |
| 3 |      SELECT STATEMENT                                  | 24   |
| 4 |        QUERY BLOCK ("$_QB_IDX_2")                     | 24   |
| 5 |          INDEX ACCESS ("ORDERS" AS _A1, "ORDERS_CUSTKEY_FK") | 24   |
=====
1 - TARGET : ORDERS.O_CUSTKEY, ORDERS.O_ORDERSTATUS

```

```

2 - SQL : SELECT /*+ INDEX( _A1, "PUBLIC"."ORDERS_CUSTKEY_FK" ) */
        "_A1"."O_CUSTKEY", "_A1"."O_ORDERSTATUS"
        FROM "PUBLIC"."ORDERS"@LOCAL AS "_A1"
        WHERE "_A1"."O_CUSTKEY" > :_V0
        AND "_A1"."O_CUSTKEY" < :_V1
        ORDER BY "_A1"."O_CUSTKEY" ASC NULLS LAST
        TARGET DOMAIN : G1(G1N1,G1N2) 24 rows,
        G2(G2N1,G2N2) 23 rows,
        G3(G3N1,G3N2) 19 rows

        MERGE SORTING
        SORT KEY : ORDERS.O_CUSTKEY
4 - TARGET : _A1.O_CUSTKEY, _A1.O_ORDERSTATUS
5 - HASH SHARD ( # 3 )
    READ INDEX COLUMN : _A1.O_CUSTKEY
    READ TABLE COLUMN : _A1.O_ORDERSTATUS
    MIN RANGE : _A1.O_CUSTKEY > :_V0
    MAX RANGE : _A1.O_CUSTKEY IS NOT NULL AND _A1.O_CUSTKEY < :_V1
<<< end print plan

```

In the execution plan above, it fetched ordered data from G1, G2, G3, then merged data, and sorted for order by key col.

## Aggregation

### Local Aggregation

It performs aggregation in the current server.

The following is an example of a local aggregation. customer is a cloned table.

```

\EXPLAIN PLAN
SELECT COUNT(DISTINCT c_nationkey)
  FROM customer;
>>> start print plan
< Execution Plan >
=====
|IDX|  NODE DESCRIPTION                                |  ROWS |
-----|-----|
| 0 |  SELECT STATEMENT                                |      1 |
| 1 |  QUERY BLOCK ("$_QB_IDX_2")                      |      1 |
| 2 |  AGGREGATION BY HASH                             |      1 |

```

```

| 3 |          INDEX ACCESS ("CUSTOMER", "CUSTOMER_NATIONKEY_FK")          | 150000 |
=====
1 - TARGET : COUNT( DISTINCT CUSTOMER.C_NATIONKEY )
2 - DISTINCT AGGREGATION : COUNT( DISTINCT CUSTOMER.C_NATIONKEY )
3 - CLONED
    READ INDEX COLUMN : CUSTOMER.C_NATIONKEY
<<< end print plan

```

## Remote Aggregation

It performs aggregation in each server.

Aggregation processing in each server has a parallel processing effect. Also, generally aggregation reduces results, so it reduces the network cost to bring the data.

```

\EXPLAIN PLAN
SELECT sum(ps_supplycost * ps_availqty) * 0.0001
  FROM partsupp,
       supplier,
       nation
 WHERE ps_suppkey = s_suppkey
       AND s_nationkey = n_nationkey
       AND n_name = 'GERMANY';
>>> start print plan
< Execution Plan >
=====
|IDX|  NODE DESCRIPTION                                     |  ROWS  |
-----
| 0 |  SELECT STATEMENT                                       |        1 |
| 1 |    QUERY BLOCK ("$_QB_IDX_2")                          |        1 |
| 2 |      SINGLE CLUSTER                                     | LOCAL/REMOTE 1 |
| 3 |        SELECT STATEMENT                                |        1 |
| 4 |          QUERY BLOCK ("$_QB_IDX_2")                    |        1 |
| 5 |            AGGREGATION BY HASH                         |        1 |
| 6 |              NESTED JOIN (INNER JOIN)                  |   10508 |
| 7 |                NESTED JOIN (INNER JOIN)               |     396 |
| 8 |                  TABLE ACCESS ("NATION" AS _A3)      |        1 |
| 9 |                    INDEX ACCESS ("SUPPLIER" AS _A2)   |     396 |
|10 |                      INDEX ACCESS ("PARTSUPP" AS _A1) |   10508 |
=====
1 - TARGET : SUM( PARTSUPP.PS_SUPPLYCOST * PARTSUPP.PS_AVAILQTY ) * 0.0001
2 - SQL : SELECT /*+ KEEP_JOINED_TABLE USE_NL_IN( _A1 )

```

```

        USE_NL_IN( _A2 )
        FULL( _A3 )
        INDEX( _A2, "PUBLIC"."SUPPLIER_NATIONKEY_FK" )
        INDEX( _A1, "PUBLIC"."PARTSUPP_SUPPKEY_FK" )
    */
    SUM( "_A1"."PS_SUPPLYCOST" * "_A1"."PS_AVAILQTY" )
FROM ( ( "PUBLIC"."NATION"@LOCAL AS "_A3"
        INNER JOIN
        "PUBLIC"."SUPPLIER"@LOCAL AS "_A2"
        ON true
        ) ALIAS "_A4"
    INNER JOIN
    "PUBLIC"."PARTSUPP"@LOCAL AS "_A1" ON true
    ) ALIAS "_A5"
WHERE "_A3"."N_NAME" = :_V0
    AND "_A2"."S_NATIONKEY" = "_A3"."N_NATIONKEY"
    AND "_A1"."PS_SUPPKEY" = "_A2"."S_SUPPKEY"
TARGET DOMAIN : G1(G1N1,G1N2) 1 rows,
                G2(G2N1,G2N2) 1 rows,
                G3(G3N1,G3N2) 1 rows

RE-AGGREGATION
    AGGREGATION : SUM( SUM( PARTSUPP.PS_SUPPLYCOST * PARTSUPP.PS_AVAILQTY ) )
4 - TARGET : SUM( _A1.PS_SUPPLYCOST * _A1.PS_AVAILQTY )
5 - AGGREGATION : SUM( _A1.PS_SUPPLYCOST * _A1.PS_AVAILQTY )
6 - JOINED COLUMN : _A1.PS_SUPPLYCOST, _A1.PS_AVAILQTY
    CONSTANT FILTER : TRUE
7 - JOINED COLUMN : _A2.S_SUPPKEY
    CONSTANT FILTER : TRUE
8 - CLONED
    READ COLUMN : _A3.N_NATIONKEY, _A3.N_NAME
    PHYSICAL FILTER : _A3.N_NAME = :_V0
9 - CLONED
    READ INDEX COLUMN : _A2.S_NATIONKEY
    READ TABLE COLUMN : _A2.S_SUPPKEY
    MIN RANGE : _A2.S_NATIONKEY = { _A3.N_NATIONKEY }
    MAX RANGE : _A2.S_NATIONKEY = { _A3.N_NATIONKEY }
10 - HASH SHARD ( # 3 )
    READ INDEX COLUMN : _A1.PS_SUPPKEY
    READ TABLE COLUMN : _A1.PS_AVAILQTY, _A1.PS_SUPPLYCOST
    MIN RANGE : _A1.PS_SUPPKEY = { _A2.S_SUPPKEY }
    MAX RANGE : _A1.PS_SUPPKEY = { _A2.S_SUPPKEY }

```

```
|| <<< end print plan
```

In the execution plan above, it fetched aggregation results from G1, G2, G3, then performed re-aggregation and returned the result.

## 15.5 Statistics Information

A query optimizer calculates the cost by using the statistics information. The statistics information used by a query optimizer are table statistics information, column statistics information, index statistics information.

- Table statistics information
  - The number of rows
- Column statistics information
  - The number of each different values
  - The number of NULL values
  - The average length of value
  - The minimum value
  - The maximum value
- Index statistics information
  - The number of each different keys

Perform **ANALYZE TABLE** statement to build the statistics information. The built statistics information is stored in the database, and the same statistics information is used until it is rebuilt.

If the statistics information is not built for a table, then build a simple statistics information by using a catalog information and the page information at the time of query execution and use it.

### Adjusting Optimizer

Generally, a query optimizer selects the most efficient plan by using the given statistics information. However, there could be a better plan than the plan selected by a query optimizer, so a user can specify to select the plan when it was not selected by a query optimizer.

Currently, a query optimizer of GOLDILOCKS provides a hint, and the hint specified by a user is preferentially applied when it is applicable regardless of the calculated cost. Therefore, if the better plan exists, a user can forcibly change the plan by using a hint.

For more information about hints, refer to **SQL Hint**.

## 15.6 SQL Hint

### Description

A hint is a comment which is used by a user to directly instruct the GOLDILOCKS optimizer how to perform the SQL statement. The user uses the hint to select the execution plan when GOLDILOCKS optimizer cannot select the appropriate execution plan due to an inaccurate statistics information.

If the user provides a hint, the optimizer will prioritize it. Therefore, it is recommended to use hints only when the execution plan selected by the optimizer is deemed incorrect.

If the hint provided by the user cannot be used, the GOLDILOCKS optimizer will determine the execution plan.

In GOLDILOCKS, hints can be used with statements such as SELECT, INSERT SELECT, UPDATE, and DELETE. Hints are enclosed with /\*+ and \*/ on either side and are specified following the keyword of each statement.

### Syntax

The following is a hint syntax.

```

<hint clause> ::=
    /*+ <hint element> [ comment ] [ [ , ] <hint element> [ comment ] ] */
<hint element> ::=
    <statement hints>
  | <query block hints>
  | <operation hints>
<statement hints> ::=
    <dml hints >
  | <fetch fail over hints>
<dml hints> ::=
    DML_GLOBAL_ROWID
<fetch fail over hints> ::=
    FETCH_FAIL_OVER
<query block hints> ::=
    <push subquery hints>
  | <cte query hints>
  | <query transformation hints>

```

```
<push subquery hints> ::=
    PUSH_SUBQ
    | NO_PUSH_SUBQ
<cte query hints> ::=
    INLINE
    | MATERIALIZE
<query transformation hints> ::=
    NO_QUERY_TRANSFORMATION
    | <unnest subquery hints>
    | <transitive closure hints>
    | <view hints>
<unnest subquery hints> ::=
    <unnest hints>
    | <unnest join operation hints>
    | <unnest join driver hints>
    | <unnest join pusher hints>
    | <unnest merge hints>
<unnest hints> ::=
    UNNEST
    | NO_UNNEST
<unnest join operation hints> ::=
    UNNEST_NL
    | UNNEST_NL_IN
    | UNNEST_NL_OUT
    | UNNEST_INL
    | UNNEST_INL_IN
    | UNNEST_INL_OUT
    | UNNEST_HASH
    | UNNEST_HASH( hash_bucket_count )
    | UNNEST_HASH_IN
    | UNNEST_HASH_IN( hash_bucket_count )
    | UNNEST_HASH_OUT
    | UNNEST_HASH_OUT( hash_bucket_count )
    | UNNEST_MERGE
    | UNNEST_MERGE_IN
    | UNNEST_MERGE_OUT
    | NL_SJ
    | NL_ISJ
    | NL_AJ
    | INL_SJ
    | INL_AJ
```



```

| MERGE_SJ
| MERGE_AJ
| HASH_SJ
| HASH_ISJ
| HASH_AJ
<unnest join driver hints> ::=
| LOCAL_UNNEST
| REMOTE_UNNEST
<unnest join pusher hints> ::=
    PUSHER_SUBQ
| NO_PUSHER_SUBQ
| PUSHER_OUTQ
| NO_PUSHER_OUTQ
<unnest merge hints> ::=
    MERGE_SUBQ
| NO_MERGE_SUBQ
<transitive closure hints> ::=
| TRANSITIVE_CLOSURE
| NO_TRANSITIVE_CLOSURE
< view hints > ::=
    <view merge hints>
| <push view predicate hints>
<view merge hints> ::=
| MERGE( view_name )
| NO_MERGE( view_name )
<push view predicate hints> ::=
    PUSH_PRED
| NO_PUSH_PRED
| PUSH_PRED( view_name[ [ , ] table_name ] )
| NO_PUSH_PRED( view_name[ [ , ] table_name ] )
<operation hints> ::=
    <access path hints>
| <join hints>
| <group hints>
| <distinct hints>
| <order hints>
| <aggr hints>
| <rownum hints>
<access path hints> ::=
    FULL( table_name )
| INDEX( table_name [ , ] [ index_name [ [ , ] index_name ] ] )

```

```

| NO_INDEX( table_name [ , ] [ index_name [ [ , ] index_name ] ] )
| INDEX_FORWARD( table_name [ , ] [ index_name [ [ , ] index_name ] ] )
| INDEX_BACKWARD( table_name [ , ] [ index_name [ [ , ] index_name ] ] )
| INDEX_ASC( table_name [ , ] [ index_name [ [ , ] index_name ] ] )
| INDEX_DESC( table_name [ , ] [ index_name [ [ , ] index_name ] ] )
| INDEX_COMBINE( table_name [ , ] [ index_name [ [ , ] index_name ] ] )
| IN_KEY_RANGE( table_name [ , ] [ index_name [ [ , ] index_name ] ] )
| ROWID( table_name )

```

```
<join hints> ::=
```

```

< join order hints >
| < join operation hints >
| < join driver hints >
| < join pusher hints >

```

```
<join order hints> ::=
```

```

ORDERED
| ORDERING( table_name [LEFT | RIGHT] [ , table_name [LEFT | RIGHT] ]
| LEADING( table_name [ [ , ] table_name ] )
| KEEP_JOINED_TABLE

```

```
<join operation hints> ::=
```

```

USE_HASH( table_name [ [ , ] table_name ] )
| USE_HASH( table_name [ [ , ] table_name ], hash_bucket_count )
| NO_USE_HASH( table_name [ [ , ] table_name ] )
| USE_MERGE( table_name [ [ , ] table_name ] )
| NO_USE_MERGE( table_name [ [ , ] table_name ] )
| USE_NL( table_name [ [ , ] table_name ] )
| NO_USE_NL( table_name [ [ , ] table_name ] )
| USE_INL( table_name [ [ , ] table_name ] )
| NO_USE_INL( table_name [ [ , ] table_name ] )
| USE_JOIN_COMBINE( alias )
| NO_USE_JOIN_COMBINE( alias )
| USE_NL_IN( alias )
| USE_NL_OUT( alias )
| USE_INL_IN( alias )
| USE_INL_OUT( alias )
| USE_HASH_IN( alias )
| USE_HASH_IN( alias, hash_bucket_count )
| USE_HASH_OUT( alias )
| USE_HASH_OUT( alias, hash_bucket_count )
| USE_MERGE_IN( alias )
| USE_MERGE_OUT( alias )

```

```
<join driver hints> ::=
```

```
| LOCAL_JOIN( alias )
| REMOTE_JOIN( alias )
<join pusher hints> ::=
    PUSHER( alias )
    | NO_PUSHER( alias )
<group hints> ::=
    <group operation hints>
    | <group driver hints>
<group operation hints> ::=
    USE_GROUP_HASH
    | USE_GROUP_HASH( hash_bucket_count )
<group driver hints> ::=
    LOCAL_GROUP
    | REMOTE_GROUP
<distinct hints> ::=
    <distinct operation hints>
    | <distinct driver hints>
<distinct operation hints> ::=
    DISTINCT_HASH
    | USE_DISTINCT_HASH( hash_bucket_count )
<distinct driver hints> ::=
    LOCAL_DISTINCT
    | REMOTE_DISTINCT
<order hints> ::=
    <order operation hints>
    | <order driver hints>
<order operation hints> ::=
    USE_ORDER_SORT
    | NO_USE_ORDER_SORT
    | USE_ORDER_LIMIT_SORT
    | NO_USE_ORDER_LIMIT_SORT
<order driver hints> ::=
    LOCAL_ORDER
    | REMOTE_ORDER
<aggr hints> ::=
    <aggr driver hint>
<aggr driver hints> ::=
    LOCAL_AGGR
    | REMOTE_AGGR
```

## Invocation and Access Rules

The user should have the privilege to perform the query to perform <hint clause> statement.

## Syntax Rules and Parameters

The followings are syntax rules to use <hint clause>.

- Multiple <hint element> can be described by using white space or comma (,) in <hint clause>.
- If there are two or more <hint element> and they can not be applied simultaneously, then only the previously described <hint element> is applied.
- If a syntactic error occurs in <hint element>, then the <hint element> is ignored, and if hint\_error property is turned on, then it is processed as a validation error for <hint clause>.
- table\_name and view\_name described in <hint clause> should be matched with one of table\_name, view\_name described in <from clause> or aliases indicating them.
- table\_name can not be described together with a schema name.
- Even when <hint element> is correctly described, but if it is not applicable, then the <hint element> is ignored.

## Examples

The following is an example of using <hint clause> in SELECT, INSERT SELECT, UPDATE, DELETE statements.

- Using <hint clause> in SELECT statement

```
SELECT /*+ INDEX(orders, o_orderdate_idx) */ *
  FROM orders
 WHERE o_orderdate < date '2019-04-12';
```

- Using <hint clause> in INSERT SELECT statement

```
INSERT INTO orders_bk SELECT /*+ INDEX(orders, o_orderdate_idx) */ *
                        FROM orders
                        WHERE o_orderdate < date '2019-04-12';
```

- Using <hint clause> in UPDATE statement

```
UPDATE /*+ INDEX(lineitem, l_shipdate_idx) */ * lineitem
      SET l_receiptdate = CURRENT_DATE
      WHERE l_shipdate = date '2020-04-12';
```

- Using <hint clause> in DELETE statement

```
DELETE /*+ INDEX(lineitem, l_shipdate_idx) */ * lineitem
WHERE l_receiptdate < date '2020-04-12';
```

The following is an example of incorrectly using a hint after setting HINT\_ERROR property to *ON* by using ALTER statement.

```
ALTER SESSION SET HINT_ERROR = ON;
SELECT /*+ INDEX(orders, o_orderdate_idx) */ *
FROM orders
WHERE o_orderdate < date '2019-04-12';
ERR-42000(16058): not applicable hint ( cannot find index ) :
SELECT /*+ INDEX(orders, o_orderdate_idx) */ *
*
ERROR at line 1:
```

For more information about descriptions and examples of all hints, refer to [Query Block Hint](#) and [Operation Hint](#).

## Statement Hint

Those hints are applied per each statement.

### <dml hints>

#### DML\_GLOBAL\_ROWID

When processing DML statement in cluster environment, a node received a user query transfers the updated information of the record to another node, then applies it.

DML statement in cluster environment is processed with the following two methods.

- Query based DML: It creates a new query to transfer the updated statement.
- Global rowid based DML: It uses the record identifier information to transfer the updated information of a specific record.

If DML\_GLOBAL\_ROWID hint is specified, then the global rowid based DML method is preferentially applied.

This hint is applied to SELECT FOR UPDATE, INSERT, UPDATE, DELETE statements.

The following is an example of applying the query based DML.

```

\EXPLAIN PLAN
DELETE FROM orders;
>>> start print plan
< Execution Plan >
=====
|  IDX  |  NODE DESCRIPTION          |
-----|-----|
|   0   |  DELETE STATEMENT ("ORDERS") |
|   1   |  QUERY BLOCK ("$_QB_IDX_2")  |
|   2   |  DML CLUSTER                |
|   3   |  TABLE ACCESS ("ORDERS")    |
=====

1 - TARGET : NOTHING
2 - WITHOUT FETCH
   Non-Fetch SQL : DELETE /*+ FULL( _A1 ) */ "_A1" FROM "PUBLIC"."ORDERS"@LOCAL AS
"_A1"
   TARGET DOMAIN : G1(G1N1,G1N2) 0 rows, G2(G2N1,G2N2) 0 rows, G3(G3N1,G3N2) 0 rows
3 - HASH SHARD ( # 3 )
   READ COLUMN : ORDERS.O_ORDERKEY, ORDERS.O_CUSTKEY
<<< end print plan

```

The following is an example of using DML\_GLOBAL\_ROWID hint.

```

\EXPLAIN PLAN
DELETE /*+ DML_GLOBAL_ROWID */ FROM orders;
>>> start print plan
< Execution Plan >
=====
|  IDX  |  NODE DESCRIPTION          |
-----|-----|
|   0   |  DELETE STATEMENT ("ORDERS") |
|   1   |  QUERY BLOCK ("$_QB_IDX_2")  |
|   2   |  PLAN BASED CLUSTER         |
|   3   |  TABLE ACCESS ("ORDERS")    |
=====

1 - TARGET : NOTHING
2 - SQL : SELECT /*+ FULL( _A1 ) */ "_A1"."$PHYSICAL_ROWID", "_A1"."O_ORDERKEY",
"_A1"."O_CUSTKEY" FROM "PUBLIC"."ORDERS"@LOCAL AS "_A1"
   TARGET DOMAIN : G1(G1N1,G1N2) 0 rows, G2(G2N1,G2N2) 0 rows, G3(G3N1,G3N2) 0 rows
3 - HASH SHARD ( # 3 )
   READ COLUMN : ORDERS.O_ORDERKEY, ORDERS.O_CUSTKEY

```

```
<<< end print plan
```

## <fetch fail over hints>

### FETCH\_FAIL\_OVER

The fetch fail over feature provides an intact fetch result by considering communication error situation while performing fetch for SELECT statement in cluster environment.

Using FETCH\_FAIL\_OVER hint enables the fetch fail over feature.

This hint is applied to SELECT statement.

The following is an example of using FETCH\_FAIL\_OVER hint.

```
\EXPLAIN PLAN
SELECT /*+ FETCH_FAIL_OVER */ o_orderkey FROM orders;
>>> start print plan
< Execution Plan >
=====
|  IDX  |  NODE DESCRIPTION  |
=====
|    0  |  SELECT STATEMENT  |
|    1  |    QUERY BLOCK ("SQB_IDX_2")  |
|    2  |    PLAN BASED CLUSTER  |
|    3  |    INDEX ACCESS ("ORDERS", "ORDERS_PK_INDEX")  |
=====
0 -  FETCH FAIL OVER
1 -  TARGET : ORDERS.O_ORDERKEY
2 -  SQL : SELECT /*+ INDEX( _A1, "PUBLIC"."ORDERS_PK_INDEX" ) */ "_A1"."O_ORDERKEY"
FROM "PUBLIC"."ORDERS"@LOCAL AS "_A1"
      TARGET DOMAIN : G1(G1N1,G1N2) 0 rows, G2(G2N1,G2N2) 0 rows, G3(G3N1,G3N2) 0 rows
3 -  HASH SHARD ( # 3 )
      READ INDEX COLUMN : ORDERS.O_ORDERKEY
<<< end print plan
```

## Query Block Hint

Those hints are applied per each query block.

## <push subquery hints>

### PUSH\_SUBQ

If PUSH\_SUBQ hint is specified, then an optimizer pushes the subquery to the lowest node of available execution plan nodes. It is a hint for a subquery which is not unnested, so PUSH\_SUBQ hint is ignored when <unnest subquery hints> is specified beforehand.

If PUSH\_SUBQ hint is not specified, then an optimizer calculates a cost, then pushes the subquery to the node whose cost is the best.

If PUSH\_SUBQ hint is used, the subquery is applied unnested as soon as possible. Therefore, the performance is upgraded, when subquery filtering has a large effect and the intermediate result can be stored by performing the subquery only once.

The following is an example of using PUSH\_SUBQ hint in this case.

```
\EXPLAIN PLAN
SELECT
    c_name,
    o_totalprice
FROM
    customer,
    orders,
    lineitem
WHERE c_custkey = o_custkey
AND o_orderkey = l_orderkey
AND o_orderkey IN (
    SELECT /*+ PUSH_SUBQ */
        l_orderkey
    FROM lineitem
    GROUP BY l_orderkey
    HAVING sum(l_quantity) > 300
);
>>> start print plan
< Execution Plan >
=====
|  IDX  |  NODE DESCRIPTION  |
-----|-----|
|   0   |  SELECT STATEMENT  |
|   1   |    QUERY BLOCK ("SQB_IDX_2")  |
|   2   |      NESTED JOIN (INNER JOIN)  |
|   3   |        MERGE JOIN (INNER JOIN)  |
```



```

| 4 |          INDEX ACCESS ("ORDERS", "ORDERS_PK_INDEX")          |
| 5 |          INDEX ACCESS ("LINEITEM", "LINEITEM_PK_INDEX")      |
| 6 |          INDEX ACCESS ("CUSTOMER", "CUSTOMER_PK_INDEX")      |
| 7 | SUB QUERY LIST                                               |
| 8 |  INLINE_VIEW ("V8") (MATERIALIZED)                            |
| 9 |  QUERY BLOCK ("QB_IDX_10")                                    |
| 10 |          GROUP HASH INSTANT                                    |
| 11 |          TABLE ACCESS ("LINEITEM")                           |
=====
1 - TARGET : CUSTOMER.C_NAME, ORDERS.O_TOTALPRICE
2 - JOINED COLUMN : CUSTOMER.C_NAME, ORDERS.O_TOTALPRICE
3 - JOINED COLUMN : ORDERS.O_CUSTKEY, ORDERS.O_TOTALPRICE
   ON FILTER (Equi) : ORDERS.O_ORDERKEY = LINEITEM.L_ORDERKEY
4 - READ INDEX COLUMN : ORDERS.O_ORDERKEY
   READ TABLE COLUMN : ORDERS.O_CUSTKEY, ORDERS.O_TOTALPRICE
   POST FILTER : ( ORDERS.O_ORDERKEY ) IN ( V8.L_ORDERKEY )
5 - READ INDEX COLUMN : LINEITEM.L_ORDERKEY
   MIN RANGE : LINEITEM.L_ORDERKEY >= {ORDERS.O_ORDERKEY}
   MAX RANGE : LINEITEM.L_ORDERKEY IS NOT NULL
6 - READ INDEX COLUMN : CUSTOMER.C_CUSTKEY
   READ TABLE COLUMN : CUSTOMER.C_NAME
   MIN RANGE : CUSTOMER.C_CUSTKEY = {ORDERS.O_CUSTKEY}
   MAX RANGE : CUSTOMER.C_CUSTKEY = {ORDERS.O_CUSTKEY}
   FETCH ONE ROW
8 - COLUMN : LINEITEM.L_ORDERKEY AS L_ORDERKEY
9 - TARGET : LINEITEM.L_ORDERKEY
10 - GROUP KEY : LINEITEM.L_ORDERKEY
   RECORD COLUMN : SUM( LINEITEM.L_QUANTITY )
   READ KEY COLUMN : LINEITEM.L_ORDERKEY
   READ RECORD COLUMN : SUM( LINEITEM.L_QUANTITY )
   PHYSICAL FILTER : SUM( LINEITEM.L_QUANTITY ) > 300
11 - READ COLUMN : LINEITEM.L_ORDERKEY, LINEITEM.L_QUANTITY
<<< end print plan

```

The subquery in the example above can be performed either in join or on orders, and it is performed on *INDEX ACCESS ("ORDERS")* which is the lowest node of available execution nodes, and it is not unnested either.

## NO\_PUSH\_SUBQ

If `NO_PUSH_SUBQ` hint is specified, then an optimizer does not push the subquery. Therefore, the subquery is performed on the top node of available execution plan nodes. It is a hint for a subquery which is no

t unnested, so NO\_PUSH\_SUBQ hint is ignored when <unnest subquery hints> is specified beforehand.

If NO\_PUSH\_SUBQ hint is not specified, then an optimizer calculates a cost, then pushes the subquery to the node whose cost is the best.

If NO\_PUSH\_SUBQ hint is specified, the subquery is applied unnested as late as possible. Therefore, if the subquery is applied before the intermediate result is reduced by the join when the subquery filtering has a small effect and the subquery is repeatedly performed, then the performance gets slow because the subquery is repeatedly performed. In this case, it is recommended to delay the time of applying the subquery as long as possible by using NO\_PUSH\_SUBQ hint.

The following is an example of using NO\_PUSH\_SUBQ hint in this case.

```
\EXPLAIN PLAN
SELECT
    c_name,
    o_totalprice
FROM
    customer,
    orders,
    lineitem
WHERE c_custkey = o_custkey
      AND o_orderkey = l_orderkey
      AND o_orderkey IN (
          SELECT /*+ NO_PUSH_SUBQ */
              l_orderkey
            FROM lineitem
           WHERE o_orderdate = l_shipdate
        );
>>> start print plan
< Execution Plan >
=====
|  IDX  |  NODE DESCRIPTION  |
-----|-----|
|   0   |  SELECT STATEMENT  |
|   1   |  QUERY BLOCK ("QB_IDX_2") |
|   2   |  NESTED JOIN (INNER JOIN) |
|   3   |  MERGE JOIN (INNER JOIN) |
|   4   |  INDEX ACCESS ("ORDERS", "ORDERS_PK_INDEX") |
|   5   |  INDEX ACCESS ("LINEITEM", "LINEITEM_PK_INDEX") |
|   6   |  INDEX ACCESS ("CUSTOMER", "CUSTOMER_PK_INDEX") |
|   7   |  SUB QUERY LIST    |
|   8   |  INLINE_VIEW ("V8") |
```

```

| 9 |          QUERY BLOCK ("QB_IDX_10")          |
| 10 |          TABLE ACCESS ("LINEITEM")          |
=====
1 - TARGET : CUSTOMER.C_NAME, ORDERS.O_TOTALPRICE
2 - JOINED COLUMN : ORDERS.O_ORDERDATE, ORDERS.O_ORDERKEY, CUSTOMER.C_NAME,
ORDERS.O_TOTALPRICE
   POST WHERE FILTER : ( ORDERS.O_ORDERKEY ) IN ( $V8.L_ORDERKEY )
3 - JOINED COLUMN : ORDERS.O_CUSTKEY, ORDERS.O_ORDERDATE, ORDERS.O_ORDERKEY,
ORDERS.O_TOTALPRICE
   ON FILTER (Equi) : ORDERS.O_ORDERKEY = LINEITEM.L_ORDERKEY
4 - READ INDEX COLUMN : ORDERS.O_ORDERKEY
   READ TABLE COLUMN : ORDERS.O_CUSTKEY, ORDERS.O_TOTALPRICE, ORDERS.O_ORDERDATE
5 - READ INDEX COLUMN : LINEITEM.L_ORDERKEY
   MIN RANGE : LINEITEM.L_ORDERKEY >= {ORDERS.O_ORDERKEY}
   MAX RANGE : LINEITEM.L_ORDERKEY IS NOT NULL
6 - READ INDEX COLUMN : CUSTOMER.C_CUSTKEY
   READ TABLE COLUMN : CUSTOMER.C_NAME
   MIN RANGE : CUSTOMER.C_CUSTKEY = {ORDERS.O_CUSTKEY}
   MAX RANGE : CUSTOMER.C_CUSTKEY = {ORDERS.O_CUSTKEY}
   FETCH ONE ROW
8 - COLUMN : LINEITEM.L_ORDERKEY AS L_ORDERKEY
9 - TARGET : LINEITEM.L_ORDERKEY
10 - READ COLUMN : LINEITEM.L_ORDERKEY, LINEITEM.L_SHIPDATE
     PHYSICAL FILTER : LINEITEM.L_SHIPDATE = {ORDERS.O_ORDERDATE}

```

The subquery in the example above can be performed either in nested join, merge join or orders index access, and it is performed on NESTED JOIN (INNER JOIN) which is the top node of available execution nodes.

## < cte query hints >

This hint is for the query block of the common table expression.

The common table expression is performed either in inline method or in materialize method.

- Inline method: It is performed in the form of inline view.
- Materialize method: It stores the result of the common table expression in an instant, then perform the query by reading rows from the instant table.

Generally, in case of when using the common table expression only once, then it is performed in inline method. In case of when using the common table expression two or more times, then it is performed in materialize method.

## INLINE

INLINE hint is valid only in a query block of the common table expression, and if this hint is specified, then the common table expression is performed like as inline view.

The following is an example of using INLINE hint.

```

gSQL> \explain plan
WITH revenue ( supplier_no, total_revenue ) AS
  (
    SELECT /*+ INLINE */
      l_suppkey,
      SUM(l_extendedprice * (1 - l_discount))
    FROM lineitem
    WHERE l_shipdate >= DATE '1996-01-01'
      AND l_shipdate < DATE '1996-01-01' + INTERVAL '3' MONTH
    GROUP BY
      l_suppkey
  )
SELECT
  s_suppkey,
  s_name,
  ROUND( total_revenue, 2 ) as total_revenue
FROM
  supplier,
  revenue
WHERE
  s_suppkey = supplier_no
  AND total_revenue = (
      select
        max(total_revenue)
      from
        revenue
    )
ORDER BY
  s_suppkey;
S_SUPPKEY S_NAME                TOTAL_REVENUE
-----
      8449 Supplier#000008449      1772627.21
1 row selected.
>>> start print plan
< Execution Plan >

```

```

=====
|  IDX  |  NODE DESCRIPTION  |
=====
|  0  |  SELECT STATEMENT  |
|  1  |  QUERY BLOCK ("QB_IDX_2")  |
|  2  |  SORT INSTANT      |
|  3  |  NESTED JOIN (INNER JOIN)  |
|  4  |  VIEW ("REVENUE")  |
|  5  |  QUERY BLOCK ("QB_IDX_7")  |
|  6  |  GROUP HASH INSTANT  |
|  7  |  TABLE ACCESS ("LINEITEM")  |
|  8  |  INDEX ACCESS ("SUPPLIER", "SUPPLIER_PK_INDEX")  |
|  9  |  SUB QUERY LIST    |
| 10  |  INLINE_VIEW ("V10")  |
| 11  |  QUERY BLOCK ("QB_IDX_14")  |
| 12  |  AGGREGATION BY HASH  |
| 13  |  VIEW ("REVENUE")  |
| 14  |  QUERY BLOCK ("QB_IDX_17")  |
| 15  |  GROUP HASH INSTANT  |
| 16  |  TABLE ACCESS ("LINEITEM")  |
=====

```

```

1 - TARGET : SUPPLIER.S_SUPPKEY, SUPPLIER.S_NAME, ROUND(REVENUE.TOTAL_REVENUE,2) AS
TOTAL_REVENUE
2 - SORT KEY : "SUPPLIER.S_SUPPKEY ASC NULLS LAST"
   RECORD COLUMN : SUPPLIER.S_NAME, ROUND(REVENUE.TOTAL_REVENUE,2)
   READ KEY COLUMN : SUPPLIER.S_SUPPKEY
   READ RECORD COLUMN : SUPPLIER.S_NAME, ROUND(REVENUE.TOTAL_REVENUE,2)
3 - JOINED COLUMN : SUPPLIER.S_SUPPKEY, SUPPLIER.S_NAME, REVENUE.TOTAL_REVENUE
4 - COLUMN : LINEITEM.L_SUPPKEY AS SUPPLIER_NO, SUM( LINEITEM.L_EXTENDEDPRICE * ( 1 -
LINEITEM.L_DISCOUNT ) ) AS TOTAL_REVENUE
5 - TARGET : LINEITEM.L_SUPPKEY, SUM( LINEITEM.L_EXTENDEDPRICE * ( 1 -
LINEITEM.L_DISCOUNT ) )
6 - GROUP KEY : LINEITEM.L_SUPPKEY
   RECORD COLUMN : SUM( LINEITEM.L_EXTENDEDPRICE * ( 1 - LINEITEM.L_DISCOUNT ) )
   READ KEY COLUMN : LINEITEM.L_SUPPKEY
   READ RECORD COLUMN : SUM( LINEITEM.L_EXTENDEDPRICE * ( 1 - LINEITEM.L_DISCOUNT ) )
   PHYSICAL FILTER : SUM( LINEITEM.L_EXTENDEDPRICE * ( 1 - LINEITEM.L_DISCOUNT ) ) =
$V10.$C0
7 - READ COLUMN : LINEITEM.L_SUPPKEY, LINEITEM.L_EXTENDEDPRICE, LINEITEM.L_DISCOUNT,
LINEITEM.L_SHIPDATE
   PHYSICAL FILTER : LINEITEM.L_SHIPDATE < DATE'1996-01-01' + CAST( '3' AS

```

```

INTERVAL(MONTH) ) AND LINEITEM.L_SHIPDATE >= DATE'1996-01-01'
  8 - READ INDEX COLUMN : SUPPLIER.S_SUPPKEY
      READ TABLE COLUMN : SUPPLIER.S_NAME
      MIN RANGE : SUPPLIER.S_SUPPKEY = {REVENUE.SUPPLIER_NO}
      MAX RANGE : SUPPLIER.S_SUPPKEY = {REVENUE.SUPPLIER_NO}
      FETCH ONE ROW
 10 - COLUMN : MAX( REVENUE.TOTAL_REVENUE ) AS $C0
 11 - TARGET : MAX( REVENUE.TOTAL_REVENUE )
 12 - AGGREGATION : MAX( REVENUE.TOTAL_REVENUE )
 13 - COLUMN : SUM( LINEITEM.L_EXTENDEDPRICE * ( 1 - LINEITEM.L_DISCOUNT ) ) AS
TOTAL_REVENUE
 14 - TARGET : SUM( LINEITEM.L_EXTENDEDPRICE * ( 1 - LINEITEM.L_DISCOUNT ) )
 15 - GROUP KEY : LINEITEM.L_SUPPKEY
      RECORD COLUMN : SUM( LINEITEM.L_EXTENDEDPRICE * ( 1 - LINEITEM.L_DISCOUNT ) )
      READ RECORD COLUMN : SUM( LINEITEM.L_EXTENDEDPRICE * ( 1 - LINEITEM.L_DISCOUNT ) )
 16 - READ COLUMN : LINEITEM.L_SUPPKEY, LINEITEM.L_EXTENDEDPRICE, LINEITEM.L_DISCOUNT,
LINEITEM.L_SHIPDATE
      PHYSICAL FILTER : LINEITEM.L_SHIPDATE < DATE'1996-01-01' + CAST( '3' AS
INTERVAL(MONTH) ) AND LINEITEM.L_SHIPDATE >= DATE'1996-01-01'
<<< end print plan

```

In the query above, revenue defined in WITH clause is used twice in SELECT query.

In this case, it is recommended to process it in materialize method not to perform revenue multiple times. However, if the cost of materialize is bigger than that of performing it twice, then use INLINE hint to prevent it performing in materialize method.

## MATERIALIZER

MATERIALIZER hint is valid only in a query block of the common table expression, and if this hint is specified, then the common table expression is performed once and the result is stored in an instant table.

The following is an example of using MATERIALIZER hint.

```

gSQL> \explain plan
WITH revenue ( supplier_no, total_revenue ) AS
(
  SELECT /*+ MATERIALIZER */
    l_suppkey,
    SUM(l_extendedprice * (1 - l_discount))
  FROM lineitem
  WHERE l_shipdate >= DATE '1996-01-01'
    AND l_shipdate < DATE '1996-01-01' + INTERVAL '3' MONTH

```

```

        GROUP BY
            l_suppkey
    )
SELECT
    s_suppkey,
    s_name,
    ROUND( total_revenue, 2 ) as total_revenue
FROM
    supplier,
    revenue
WHERE
    s_suppkey = supplier_no
    AND total_revenue = (
        select
            max(total_revenue)
        from
            revenue
    )
ORDER BY
    s_suppkey;

```

```

S_SUPPKEY S_NAME                TOTAL_REVENUE
-----
      8449 Supplier#000008449      1772627.21

```

1 row selected.

>>> start print plan

< Execution Plan >

```

=====
|  IDX  |  NODE DESCRIPTION  |
-----
|   0   |  SELECT STATEMENT  |
|   1   |  QUERY BLOCK ("QB_IDX_2") |
|   2   |  SORT INSTANT      |
|   3   |  NESTED JOIN (INNER JOIN) |
|   4   |  MTR ACCESS ("REVENUE") |
|   5   |  INDEX ACCESS ("SUPPLIER", "SUPPLIER_PK_INDEX") |
|   6   |  MTR LOADER LIST   |
|   7   |  MTR LOADER ("REVENUE") |
|   8   |  VIEW ("REVENUE")  |
|   9   |  QUERY BLOCK ("QB_IDX_7") |
|  10   |  GROUP HASH INSTANT |
|  11   |  TABLE ACCESS ("LINEITEM") |

```

```

| 12 | SUB QUERY LIST |
| 13 |   INLINE_VIEW ("V12") |
| 14 |     QUERY BLOCK ("QB_IDX_14") |
| 15 |       MTR ACCESS ("REVENUE") |

```

```

=====
1 - TARGET : SUPPLIER.S_SUPPKEY,
          SUPPLIER.S_NAME,
          ROUND(REVENUE.TOTAL_REVENUE,2) AS TOTAL_REVENUE
2 - SORT KEY : "SUPPLIER.S_SUPPKEY ASC NULLS LAST"
  RECORD COLUMN : SUPPLIER.S_NAME, ROUND(REVENUE.TOTAL_REVENUE,2)
  READ KEY COLUMN : SUPPLIER.S_SUPPKEY
  READ RECORD COLUMN : SUPPLIER.S_NAME,
                    ROUND(REVENUE.TOTAL_REVENUE,2)
3 - JOINED COLUMN : SUPPLIER.S_SUPPKEY,
                  SUPPLIER.S_NAME,
                  REVENUE.TOTAL_REVENUE
4 - READ COLUMN : REVENUE.SUPPLIER_NO, REVENUE.TOTAL_REVENUE
  PHYSICAL FILTER : REVENUE.TOTAL_REVENUE = V12.C0
5 - READ INDEX COLUMN : SUPPLIER.S_SUPPKEY
  READ TABLE COLUMN : SUPPLIER.S_NAME
  MIN RANGE : SUPPLIER.S_SUPPKEY = {REVENUE.SUPPLIER_NO}
  MAX RANGE : SUPPLIER.S_SUPPKEY = {REVENUE.SUPPLIER_NO}
  FETCH ONE ROW
7 - RECORD COLUMN : REVENUE.SUPPLIER_NO, REVENUE.TOTAL_REVENUE
8 - COLUMN : LINEITEM.L_SUPPKEY AS SUPPLIER_NO,
          SUM( LINEITEM.L_EXTENDEDPRICE * ( 1 - LINEITEM.L_DISCOUNT ) ) AS
TOTAL_REVENUE
9 - TARGET : LINEITEM.L_SUPPKEY,
          SUM( LINEITEM.L_EXTENDEDPRICE * ( 1 - LINEITEM.L_DISCOUNT ) )
10 - GROUP KEY : LINEITEM.L_SUPPKEY
  RECORD COLUMN : SUM( LINEITEM.L_EXTENDEDPRICE * ( 1 - LINEITEM.L_DISCOUNT ) )
  READ KEY COLUMN : LINEITEM.L_SUPPKEY
  READ RECORD COLUMN : SUM( LINEITEM.L_EXTENDEDPRICE * ( 1 - LINEITEM.L_DISCOUNT ) )
11 - READ COLUMN : LINEITEM.L_SUPPKEY,
                LINEITEM.L_EXTENDEDPRICE,
                LINEITEM.L_DISCOUNT, LINEITEM.L_SHIPDATE
  PHYSICAL FILTER : LINEITEM.L_SHIPDATE < DATE'1996-01-01' + CAST( '3' AS
INTERVAL(MONTH) ) AND LINEITEM.L_SHIPDATE >= DATE'1996-01-01'
13 - COLUMN : MAX( REVENUE.TOTAL_REVENUE ) AS C0
14 - TARGET : MAX( REVENUE.TOTAL_REVENUE )
15 - READ COLUMN : REVENUE.TOTAL_REVENUE

```



```

                AGGREGATION : MAX( REVENUE.TOTAL_REVENUE )
<<< end print plan

```

In the query above, revenue defined in WITH clause is used twice in SELECT query.

When performing it in materialize method, then it performs the common table expression only once and stores the result in an instant table, then uses it, so the operating time is reduced.

## NO\_QUERY\_TRANSFORMATION

If NO\_QUERY\_TRANSFORMATION hint is specified, then the query block in which the hint is specified and all query blocks below it do not perform the query transformation.

The following is an example of using NO\_QUERY\_TRANSFORMATION hint.

```

\EXPLAIN PLAN
SELECT /*+ NO_QUERY_TRANSFORMATION */
    s_name,
    l_quantity
FROM supplier,
(
    SELECT
        l_supkey,
        l_quantity
    FROM lineitem
    WHERE l_shipdate >= date '1996-01-01'
        AND l_shipdate < date '1996-01-01' + interval '3' month
) lineitem_view
WHERE s_suppkey = l_supkey
    AND s_nationkey IN (
        SELECT n_nationkey
        FROM nation
        WHERE n_name = 'FRANCE' OR n_name = 'GERMANY'
    )
;
>>> start print plan
< Execution Plan >
=====
|  IDX  |  NODE DESCRIPTION                                |
-----|-----|
|    0  |  SELECT STATEMENT                                |
|    1  |  QUERY BLOCK ("SQB_IDX_2")                       |
|    2  |  NESTED JOIN (INNER JOIN)                       |

```

```

| 3 |      INLINE_VIEW ("LINEITEM_VIEW")      |
| 4 |      QUERY_BLOCK ("SQB_IDX_7")          |
| 5 |      TABLE_ACCESS ("LINEITEM")         |
| 6 |      INDEX_ACCESS ("SUPPLIER", "SUPPLIER_PK_INDEX") |
| 7 | SUB_QUERY_LIST                           |
| 8 |      INLINE_VIEW ("V8") (MATERIALIZED)  |
| 9 |      QUERY_BLOCK ("SQB_IDX_12")         |
|10 |      TABLE_ACCESS ("NATION")           |
=====
1 - TARGET : SUPPLIER.S_NAME, LINEITEM_VIEW.L_QUANTITY
2 - JOINED COLUMN : SUPPLIER.S_NATIONKEY, SUPPLIER.S_NAME, LINEITEM_VIEW.L_QUANTITY
   POST WHERE FILTER : ( SUPPLIER.S_NATIONKEY ) IN ( V8.N_NATIONKEY )
3 - COLUMN : LINEITEM.L_SUPPKEY AS L_SUPPKEY, LINEITEM.L_QUANTITY AS L_QUANTITY
4 - TARGET : LINEITEM.L_SUPPKEY, LINEITEM.L_QUANTITY
5 - READ COLUMN : LINEITEM.L_SUPPKEY, LINEITEM.L_QUANTITY, LINEITEM.L_SHIPDATE
   PHYSICAL FILTER : LINEITEM.L_SHIPDATE >= DATE'1996-01-01' AND LINEITEM.L_SHIPDATE
< DATE'1996-01-01' + CAST( '3' AS INTERVAL(MONTH) )
6 - READ INDEX COLUMN : SUPPLIER.S_SUPPKEY
   READ TABLE COLUMN : SUPPLIER.S_NAME, SUPPLIER.S_NATIONKEY
   MIN RANGE : SUPPLIER.S_SUPPKEY = {LINEITEM_VIEW.L_SUPPKEY}
   MAX RANGE : SUPPLIER.S_SUPPKEY = {LINEITEM_VIEW.L_SUPPKEY}
   FETCH ONE ROW
8 - COLUMN : NATION.N_NATIONKEY AS N_NATIONKEY
9 - TARGET : NATION.N_NATIONKEY
10 - READ COLUMN : NATION.N_NATIONKEY, NATION.N_NAME
     LOGICAL FILTER : NATION.N_NAME = 'FRANCE' OR NATION.N_NAME = 'GERMANY'
<<< end print plan

```

A simple view merging and a subquery unnesting can be applied in the example above, but neither of those query transformation methods are applied due to the `NO_QUERY_TRANSFORMATION` hint.

## <unnest subquery hints>

<unnest subquery hints> are <unnest hints>, <unnest join operation hints>, <unnest join driver hints>, <unnest join pusher hints>, <unnest merge hints>.

Subquery unnesting is a part of the query transformation process. Therefore, if the `NO_QUERY_TRANSFORMATION` hint is specified, then subquery unnesting is not performed.

If the `NO_QUERY_TRANSFORMATION` hint and <unnest subquery hints> are simultaneously specified in the same subquery, then the first specified hint is applied only and other hints are ignored.

If <push subquery hints> and <unnest subquery hints> are simultaneously specified in the same subquery, then the first specified hint is applied only and other hints are ignored as well. This is because <push subquery hints> is a hint for a non-unnested subquery and cannot be used together with <unnest subquery hints>.

Descriptions and examples for the hints are as follows.

## <unnest hints>

### UNNEST

If UNNEST hint is specified, an optimizer transforms the subquery into the join statement which guarantees the same result. However, the hint can be applied when it satisfies the subquery unnesting constraints. If the hint is not applicable to the subquery, then the hint is ignored.

For more information about constraints, refer to **SubQuery Unnesting**.

The following is an example of using UNNEST hint.

```
\EXPLAIN PLAN
SELECT
    o_orderdate,
    o_totalprice
FROM orders
WHERE o_orderkey IN (
    SELECT /*+ UNNEST */
        l_orderkey
    FROM lineitem
    GROUP BY l_orderkey
    HAVING sum(l_quantity) > 300
)
;
>>> start print plan
< Execution Plan >
=====
|  IDX  |  NODE DESCRIPTION  |
-----|-----|
|   0   |  SELECT STATEMENT  |
|   1   |    QUERY BLOCK ("QB_IDX_2")  |
|   2   |      NESTED JOIN (INNER JOIN)  |
|   3   |        INLINE_VIEW ("V4")  |
|   4   |          QUERY BLOCK ("QB_IDX_6")  |
|   5   |            GROUP HASH INSTANT  |
|   6   |              TABLE ACCESS ("LINEITEM")  |
```

```

| 7 | INDEX ACCESS ("ORDERS", "ORDERS_PK_INDEX") |
=====
1 - TARGET : ORDERS.O_ORDERDATE, ORDERS.O_TOTALPRICE
2 - JOINED COLUMN : ORDERS.O_ORDERDATE, ORDERS.O_TOTALPRICE
3 - COLUMN : LINEITEM.L_ORDERKEY AS L_ORDERKEY
4 - TARGET : LINEITEM.L_ORDERKEY
5 - GROUP KEY : LINEITEM.L_ORDERKEY
   RECORD COLUMN : SUM( LINEITEM.L_QUANTITY )
   READ KEY COLUMN : LINEITEM.L_ORDERKEY
   READ RECORD COLUMN : SUM( LINEITEM.L_QUANTITY )
   PHYSICAL FILTER : SUM( LINEITEM.L_QUANTITY ) > 300
6 - READ COLUMN : LINEITEM.L_ORDERKEY, LINEITEM.L_QUANTITY
7 - READ INDEX COLUMN : ORDERS.O_ORDERKEY
   READ TABLE COLUMN : ORDERS.O_TOTALPRICE, ORDERS.O_ORDERDATE
   MIN RANGE : ORDERS.O_ORDERKEY = {$V4.L_ORDERKEY}
   MAX RANGE : ORDERS.O_ORDERKEY = {$V4.L_ORDERKEY}
   FETCH ONE ROW
<<< end print plan

```

## NO\_UNNEST

If NO\_UNNEST hint is specified, an optimizer does not unnest a subquery. In other words, the subquery is filtered as it is.

The following is an example of using NO\_UNNEST hint.

```

\EXPLAIN PLAN
SELECT
    o_orderdate,
    o_totalprice
FROM orders
WHERE o_orderkey IN (
    SELECT /*+ NO_UNNEST */
        l_orderkey
    FROM lineitem
    GROUP BY l_orderkey
    HAVING sum(l_quantity) > 300
)
;
no rows selected.
>>> start print plan
< Execution Plan >

```

```

=====
|  IDX  |  NODE DESCRIPTION                                |
-----
|   0   |  SELECT STATEMENT                                |
|   1   |    QUERY BLOCK ("QB_IDX_2")                      |
|   2   |      TABLE ACCESS ("ORDERS")                    |
|   3   |    SUB QUERY LIST                                |
|   4   |      INLINE_VIEW ("V4") (MATERIALIZED)           |
|   5   |        QUERY BLOCK ("QB_IDX_6")                  |
|   6   |          GROUP HASH INSTANT                       |
|   7   |            TABLE ACCESS ("LINEITEM")            |
=====

1  -  TARGET : ORDERS.O_ORDERDATE, ORDERS.O_TOTALPRICE
2  -  READ COLUMN : ORDERS.O_ORDERKEY, ORDERS.O_TOTALPRICE, ORDERS.O_ORDERDATE
      POST FILTER : ( ORDERS.O_ORDERKEY ) IN ( V4.L_ORDERKEY )
4  -  COLUMN : LINEITEM.L_ORDERKEY AS L_ORDERKEY
5  -  TARGET : LINEITEM.L_ORDERKEY
6  -  GROUP KEY : LINEITEM.L_ORDERKEY
      RECORD COLUMN : SUM( LINEITEM.L_QUANTITY )
      READ KEY COLUMN : LINEITEM.L_ORDERKEY
      READ RECORD COLUMN : SUM( LINEITEM.L_QUANTITY )
      PHYSICAL FILTER : SUM( LINEITEM.L_QUANTITY ) > 300
7  -  READ COLUMN : LINEITEM.L_ORDERKEY, LINEITEM.L_QUANTITY
<<< end print plan

```

## <unnest join operation hints>

If <unnest join operation hints> is specified, an optimizer transforms the subquery into the join statement which guarantees the same result, and performs the join as specified by a hint.

### UNNEST\_NL

If UNNEST\_NL hint is specified, an optimizer transforms the subquery into the join statement which guarantees the same result, and performs the join by nested loop join method.

The following is an example of using UNNEST\_NL hint.

```

\EXPLAIN PLAN
SELECT
    o_orderdate,
    o_totalprice
FROM orders
WHERE o_orderkey IN (

```

```

        SELECT /*+ UNNEST_NL */
              l_orderkey
        FROM   lineitem
        GROUP BY l_orderkey
        HAVING sum(l_quantity) > 300
    )
;
>>> start print plan
< Execution Plan >
=====
|  IDX  |  NODE DESCRIPTION                                |
-----|-----|
|   0   |  SELECT STATEMENT                                |
|   1   |    QUERY BLOCK ("QB_IDX_2")                      |
|   2   |      NESTED JOIN (INNER JOIN)                   |
|   3   |        INLINE_VIEW ("V4")                       |
|   4   |          QUERY BLOCK ("QB_IDX_6")                |
|   5   |            GROUP HASH INSTANT                    |
|   6   |              TABLE ACCESS ("LINEITEM")         |
|   7   |                INDEX ACCESS ("ORDERS", "ORDERS_PK_INDEX")
=====
1 - TARGET : ORDERS.O_ORDERDATE, ORDERS.O_TOTALPRICE
2 - JOINED COLUMN : ORDERS.O_ORDERDATE, ORDERS.O_TOTALPRICE
3 - COLUMN : LINEITEM.L_ORDERKEY AS L_ORDERKEY
4 - TARGET : LINEITEM.L_ORDERKEY
5 - GROUP KEY : LINEITEM.L_ORDERKEY
   RECORD COLUMN : SUM( LINEITEM.L_QUANTITY )
   READ KEY COLUMN : LINEITEM.L_ORDERKEY
   READ RECORD COLUMN : SUM( LINEITEM.L_QUANTITY )
   PHYSICAL FILTER : SUM( LINEITEM.L_QUANTITY ) > 300
6 - READ COLUMN : LINEITEM.L_ORDERKEY, LINEITEM.L_QUANTITY
7 - READ INDEX COLUMN : ORDERS.O_ORDERKEY
   READ TABLE COLUMN : ORDERS.O_TOTALPRICE, ORDERS.O_ORDERDATE
   MIN RANGE : ORDERS.O_ORDERKEY = {V4.L_ORDERKEY}
   MAX RANGE : ORDERS.O_ORDERKEY = {V4.L_ORDERKEY}
   FETCH ONE ROW
<<< end print plan

```

In the example above, a subquery is unnested to `INLINE_VIEW ("V4")` and participates in `NESTED JOIN`.

## UNNEST\_NL\_IN

If UNNEST\_NL\_IN hint is specified, an optimizer transforms the subquery into the join statement which guarantees the same result, and performs the join by nested loop join method. Then, it places the subquery which is unnested to a table or a view, on the right of the join.

The following is an example of using UNNEST\_NL\_IN hint.

```
\EXPLAIN PLAN
SELECT
    o_orderdate,
    o_totalprice
FROM orders
WHERE o_orderkey IN (
    SELECT /*+ UNNEST_NL_IN */
        l_orderkey
    FROM   lineitem
    GROUP BY l_orderkey
    HAVING sum(l_quantity) > 300
)
;
>>> start print plan
< Execution Plan >
=====
|  IDX  |  NODE DESCRIPTION          |
-----|-----|
|   0   |  SELECT STATEMENT          |
|   1   |    QUERY BLOCK ("SQB_IDX_2") |
|   2   |      NESTED JOIN (INNER JOIN) |
|   3   |        TABLE ACCESS ("ORDERS") |
|   4   |          INLINE_VIEW ("V5") |
|   5   |            QUERY BLOCK ("SQB_IDX_6") |
|   6   |              GROUP          |
|   7   |                INDEX ACCESS ("LINEITEM", "LINEITEM_PK_INDEX") |
=====
1 - TARGET : ORDERS.O_ORDERDATE, ORDERS.O_TOTALPRICE
2 - JOINED COLUMN : ORDERS.O_ORDERDATE, ORDERS.O_TOTALPRICE
3 - READ COLUMN : ORDERS.O_ORDERKEY, ORDERS.O_TOTALPRICE, ORDERS.O_ORDERDATE
4 - COLUMN : LINEITEM.L_ORDERKEY AS L_ORDERKEY
5 - TARGET : LINEITEM.L_ORDERKEY
6 - GROUP KEY : LINEITEM.L_ORDERKEY
   RECORD COLUMN : SUM( LINEITEM.L_QUANTITY )
```

```

          LOGICAL FILTER : SUM( LINEITEM.L_QUANTITY ) > 300
7 - READ INDEX COLUMN : LINEITEM.L_ORDERKEY
    READ TABLE COLUMN : LINEITEM.L_QUANTITY
      MIN RANGE : LINEITEM.L_ORDERKEY = {ORDERS.O_ORDERKEY}
      MAX RANGE : LINEITEM.L_ORDERKEY = {ORDERS.O_ORDERKEY}
<<< end print plan

```

In the example above, a subquery is unnested to `INLINE_VIEW ("V5")`, becomes a right child of `NESTED JOIN` and participates in the join.

## UNNEST\_NL\_OUT

If `UNNEST_NL_OUT` hint is specified, an optimizer transforms the subquery into the join statement which guarantees the same result, and performs the join by nested loop join method. Then, it places the subquery which is unnested to a table or a view, on the left of the join.

The following is an example of using `UNNEST_NL_OUT` hint.

```

\EXPLAIN PLAN
SELECT
    o_orderdate,
    o_totalprice
FROM orders
WHERE o_orderkey IN (
    SELECT /*+ UNNEST_NL_OUT */
        l_orderkey
    FROM lineitem
    GROUP BY l_orderkey
    HAVING sum(l_quantity) > 300
)
;
>>> start print plan
< Execution Plan >
=====
|  IDX  |  NODE DESCRIPTION  |
-----|-----|
|   0   |  SELECT STATEMENT  |
|   1   |    QUERY BLOCK ("QB_IDX_2")  |
|   2   |      NESTED JOIN (INNER JOIN)  |
|   3   |        INLINE_VIEW ("V4")  |
|   4   |          QUERY BLOCK ("QB_IDX_6")  |
|   5   |            GROUP HASH INSTANT  |
|   6   |              TABLE ACCESS ("LINEITEM")  |

```



```

| 7 | INDEX ACCESS ("ORDERS", "ORDERS_PK_INDEX") |
=====
1 - TARGET : ORDERS.O_ORDERDATE, ORDERS.O_TOTALPRICE
2 - JOINED COLUMN : ORDERS.O_ORDERDATE, ORDERS.O_TOTALPRICE
3 - COLUMN : LINEITEM.L_ORDERKEY AS L_ORDERKEY
4 - TARGET : LINEITEM.L_ORDERKEY
5 - GROUP KEY : LINEITEM.L_ORDERKEY
   RECORD COLUMN : SUM( LINEITEM.L_QUANTITY )
   READ KEY COLUMN : LINEITEM.L_ORDERKEY
   READ RECORD COLUMN : SUM( LINEITEM.L_QUANTITY )
   PHYSICAL FILTER : SUM( LINEITEM.L_QUANTITY ) > 300
6 - READ COLUMN : LINEITEM.L_ORDERKEY, LINEITEM.L_QUANTITY
7 - READ INDEX COLUMN : ORDERS.O_ORDERKEY
   READ TABLE COLUMN : ORDERS.O_TOTALPRICE, ORDERS.O_ORDERDATE
   MIN RANGE : ORDERS.O_ORDERKEY = {$V4.L_ORDERKEY}
   MAX RANGE : ORDERS.O_ORDERKEY = {$V4.L_ORDERKEY}
   FETCH ONE ROW
<<< end print plan

```

In the example above, a subquery is unnested to `INLINE_VIEW` ("V4"), becomes a left child of `NESTED JOIN` and participates in the join.

### UNNEST\_INL

If `UNNEST_INL` hint is specified, an optimizer transforms the subquery into the join statement which guarantees the same result, and performs the join by instant nested loop join method.

The following is an example of using `UNNEST_INL` hint.

```

\EXPLAIN PLAN
SELECT
    o_orderdate,
    o_totalprice
FROM orders
WHERE o_orderkey IN (
        SELECT /*+ UNNEST_INL */
            l_orderkey
        FROM lineitem
        GROUP BY l_orderkey
        HAVING sum(l_quantity) > 300
    )
;
>>> start print plan

```

&lt; Execution Plan &gt;

```

=====
|  IDX  |  NODE DESCRIPTION  |
-----
|   0   |  SELECT STATEMENT  |
|   1   |    QUERY BLOCK ("QB_IDX_2")  |
|   2   |      NESTED JOIN (INNER JOIN)  |
|   3   |        TABLE ACCESS ("ORDERS")  |
|   4   |          SORT JOIN INSTANT  |
|   5   |            INLINE_VIEW ("V6")  |
|   6   |              QUERY BLOCK ("QB_IDX_6")  |
|   7   |                GROUP HASH INSTANT  |
|   8   |                  TABLE ACCESS ("LINEITEM")  |
=====

1 - TARGET : ORDERS.O_ORDERDATE, ORDERS.O_TOTALPRICE
2 - JOINED COLUMN : ORDERS.O_ORDERDATE, ORDERS.O_TOTALPRICE
3 - READ COLUMN : ORDERS.O_ORDERKEY, ORDERS.O_TOTALPRICE, ORDERS.O_ORDERDATE
4 - SORT KEY : "$V6.L_ORDERKEY ASC NULLS LAST"
   READ KEY COLUMN : $V6.L_ORDERKEY
   MIN RANGE : $V6.L_ORDERKEY = {ORDERS.O_ORDERKEY}
   MAX RANGE : $V6.L_ORDERKEY = {ORDERS.O_ORDERKEY}
5 - COLUMN : LINEITEM.L_ORDERKEY AS L_ORDERKEY
6 - TARGET : LINEITEM.L_ORDERKEY
7 - GROUP KEY : LINEITEM.L_ORDERKEY
   RECORD COLUMN : SUM( LINEITEM.L_QUANTITY )
   READ KEY COLUMN : LINEITEM.L_ORDERKEY
   READ RECORD COLUMN : SUM( LINEITEM.L_QUANTITY )
   PHYSICAL FILTER : SUM( LINEITEM.L_QUANTITY ) > 300
8 - READ COLUMN : LINEITEM.L_ORDERKEY, LINEITEM.L_QUANTITY

<<< end print plan

```

In the example above, a subquery is unnested to `INLINE_VIEW ("V6")` and participates in `NESTED JOIN`.

### UNNEST\_INL\_IN

If `UNNEST_INL_IN` hint is specified, an optimizer transforms the subquery into the join statement which guarantees the same result, and performs the join by instant nested loop join method. Then, it places the subquery which is unnested to a table or a view, on the right of the join.

The following is an example of using `UNNEST_INL_IN` hint.

```

\EXPLAIN PLAN
SELECT
    o_orderdate,
    o_totalprice
FROM orders
WHERE o_orderkey IN (
    SELECT /*+ UNNEST_INL_IN */
        l_orderkey
    FROM   lineitem
    GROUP BY l_orderkey
    HAVING sum(l_quantity) > 300
)

```

```
;
```

```
no rows selected.
```

```
>>> start print plan
```

```
< Execution Plan >
```

```

=====
|  IDX  |  NODE DESCRIPTION                               |
-----|-----|
|   0   |  SELECT STATEMENT                               |
|   1   |    QUERY BLOCK ("SQB_IDX_2")                     |
|   2   |      NESTED JOIN (INNER JOIN)                   |
|   3   |        TABLE ACCESS ("ORDERS")                 |
|   4   |          SORT JOIN INSTANT                       |
|   5   |            INLINE_VIEW ("V6")                   |
|   6   |              QUERY BLOCK ("SQB_IDX_6")          |
|   7   |                GROUP HASH INSTANT              |
|   8   |                  TABLE ACCESS ("LINEITEM")     |
=====

```

```

1 - TARGET : ORDERS.O_ORDERDATE, ORDERS.O_TOTALPRICE
2 - JOINED COLUMN : ORDERS.O_ORDERDATE, ORDERS.O_TOTALPRICE
3 - READ COLUMN : ORDERS.O_ORDERKEY, ORDERS.O_TOTALPRICE, ORDERS.O_ORDERDATE
4 - SORT KEY : "V6.L_ORDERKEY ASC NULLS LAST"
   READ KEY COLUMN : V6.L_ORDERKEY
   MIN RANGE : V6.L_ORDERKEY = {ORDERS.O_ORDERKEY}
   MAX RANGE : V6.L_ORDERKEY = {ORDERS.O_ORDERKEY}
5 - COLUMN : LINEITEM.L_ORDERKEY AS L_ORDERKEY
6 - TARGET : LINEITEM.L_ORDERKEY
7 - GROUP KEY : LINEITEM.L_ORDERKEY
   RECORD COLUMN : SUM( LINEITEM.L_QUANTITY )
   READ KEY COLUMN : LINEITEM.L_ORDERKEY

```

```

      READ RECORD COLUMN : SUM( LINEITEM.L_QUANTITY )
      PHYSICAL FILTER : SUM( LINEITEM.L_QUANTITY ) > 300
8 - READ COLUMN : LINEITEM.L_ORDERKEY, LINEITEM.L_QUANTITY
<<< end print plan

```

In the example above, a subquery is unnested to `INLINE_VIEW ("V6")`, becomes a right child of `NESTED JOIN` and participates in the join.

## UNNEST\_INL\_OUT

If `UNNEST_INL_OUT` hint is specified, an optimizer transforms the subquery into the join statement which guarantees the same result, and performs the join by instant nested loop join method. Then, it places the subquery which is unnested to a table or a view, on the left of the join.

The following is an example of using `UNNEST_INL_OUT` hint.

```

\EXPLAIN PLAN
SELECT
  o_orderdate,
  o_totalprice
FROM orders
WHERE o_orderkey IN (
      SELECT /*+ UNNEST_INL_OUT */
      l_orderkey
      FROM lineitem
      GROUP BY l_orderkey
      HAVING sum(l_quantity) > 300
    )
;
no rows selected.
>>> start print plan
< Execution Plan >
-----
|  IDX  |  NODE DESCRIPTION  |
-----
|   0   |  SELECT STATEMENT  |
|   1   |    QUERY BLOCK ("QB_IDX_2")  |
|   2   |      NESTED JOIN (INNER JOIN)  |
|   3   |        INLINE_VIEW ("V4")  |
|   4   |          QUERY BLOCK ("QB_IDX_6")  |
|   5   |            GROUP HASH INSTANT  |
|   6   |              TABLE ACCESS ("LINEITEM")  |
|   7   |                SORT JOIN INSTANT  |

```

```

| 8 |          TABLE ACCESS ("ORDERS")          |
=====
1 - TARGET : ORDERS.O_ORDERDATE, ORDERS.O_TOTALPRICE
2 - JOINED COLUMN : ORDERS.O_ORDERDATE, ORDERS.O_TOTALPRICE
3 - COLUMN : LINEITEM.L_ORDERKEY AS L_ORDERKEY
4 - TARGET : LINEITEM.L_ORDERKEY
5 - GROUP KEY : LINEITEM.L_ORDERKEY
   RECORD COLUMN : SUM( LINEITEM.L_QUANTITY )
   READ KEY COLUMN : LINEITEM.L_ORDERKEY
   READ RECORD COLUMN : SUM( LINEITEM.L_QUANTITY )
   PHYSICAL FILTER : SUM( LINEITEM.L_QUANTITY ) > 300
6 - READ COLUMN : LINEITEM.L_ORDERKEY, LINEITEM.L_QUANTITY
7 - SORT KEY : "ORDERS.O_ORDERKEY ASC NULLS LAST"
   RECORD COLUMN : ORDERS.O_ORDERDATE, ORDERS.O_TOTALPRICE
   READ KEY COLUMN : ORDERS.O_ORDERKEY
   READ RECORD COLUMN : ORDERS.O_ORDERDATE, ORDERS.O_TOTALPRICE
   MIN RANGE : ORDERS.O_ORDERKEY = {$V4.L_ORDERKEY}
   MAX RANGE : ORDERS.O_ORDERKEY = {$V4.L_ORDERKEY}
8 - READ COLUMN : ORDERS.O_ORDERKEY, ORDERS.O_TOTALPRICE, ORDERS.O_ORDERDATE
<<< end print plan

```

In the example above, a subquery is unnested to `INLINE_VIEW` ("`$V4`"), becomes a left child of `NESTED JOIN` and participates in the join.

## UNNEST\_HASH

If `UNNEST_HASH` hint is specified, an optimizer transforms the subquery into the join statement which guarantees the same result, and performs the join by hash join method.

The following is an example of using `UNNEST_HASH` hint.

```

\EXPLAIN PLAN
SELECT
    o_orderdate,
    o_totalprice
FROM orders
WHERE o_orderkey IN (
    SELECT /*+ UNNEST_HASH */
        l_orderkey
    FROM lineitem
    GROUP BY l_orderkey
    HAVING sum(l_quantity) > 300
)

```

```

;
>>> start print plan
< Execution Plan >
=====
|  IDX  |  NODE DESCRIPTION  |
-----|-----|
|   0   |  SELECT STATEMENT  |
|   1   |    QUERY BLOCK ("QB_IDX_2")  |
|   2   |      HASH JOIN (INNER JOIN)  |
|   3   |        TABLE ACCESS ("ORDERS")  |
|   4   |      HASH JOIN INSTANT  |
|   5   |        INLINE_VIEW ("V6")  |
|   6   |          QUERY BLOCK ("QB_IDX_6")  |
|   7   |            GROUP HASH INSTANT  |
|   8   |              TABLE ACCESS ("LINEITEM")  |
=====
1 - TARGET : ORDERS.O_ORDERDATE, ORDERS.O_TOTALPRICE
2 - JOINED COLUMN : ORDERS.O_ORDERDATE, ORDERS.O_TOTALPRICE
3 - READ COLUMN : ORDERS.O_ORDERKEY, ORDERS.O_TOTALPRICE, ORDERS.O_ORDERDATE
4 - HASH KEY : V6.L_ORDERKEY
   READ KEY COLUMN : V6.L_ORDERKEY
   HASH FILTER : V6.L_ORDERKEY = ORDERS.O_ORDERKEY
   FETCH ONE ROW
5 - COLUMN : LINEITEM.L_ORDERKEY AS L_ORDERKEY
6 - TARGET : LINEITEM.L_ORDERKEY
7 - GROUP KEY : LINEITEM.L_ORDERKEY
   RECORD COLUMN : SUM( LINEITEM.L_QUANTITY )
   READ KEY COLUMN : LINEITEM.L_ORDERKEY
   READ RECORD COLUMN : SUM( LINEITEM.L_QUANTITY )
   PHYSICAL FILTER : SUM( LINEITEM.L_QUANTITY ) > 300
8 - READ COLUMN : LINEITEM.L_ORDERKEY, LINEITEM.L_QUANTITY
<<< end print plan

```

In the example above, a subquery is unnested to `INLINE_VIEW ("V6")` and participates in `NESTED JOIN`.

### **UNNEST\_HASH(hash\_bucket\_count)**

`UNNEST_HASH(hash_bucket_count)` hint is as same as `UNNEST_HASH` hint, but in addition to that it can specify the hash bucket count.

Therefore, if `UNNEST_HASH(hash_bucket_count)` hint is used, then it creates hash buckets as many as `hash_bucket_count`.

The following is an example of using UNNEST\_HASH(hash\_bucket\_count) hint.

```

\EXPLAIN PLAN
SELECT
    o_orderdate,
    o_totalprice
FROM orders
WHERE o_orderkey IN (
    SELECT /*+ UNNEST_HASH(3) */
        l_orderkey
    FROM lineitem
    GROUP BY l_orderkey
    HAVING sum(l_quantity) > 300
)
;
>>> start print plan
< Execution Plan >
=====
|  IDX  |  NODE DESCRIPTION  |
-----|-----|
|   0   |  SELECT STATEMENT  |
|   1   |    QUERY BLOCK ("QB_IDX_2")  |
|   2   |      HASH JOIN (INNER JOIN)  |
|   3   |        TABLE ACCESS ("ORDERS")  |
|   4   |          HASH JOIN INSTANT  |
|   5   |            INLINE_VIEW ("V6")  |
|   6   |              QUERY BLOCK ("QB_IDX_6")  |
|   7   |                GROUP HASH INSTANT  |
|   8   |                  TABLE ACCESS ("LINEITEM")  |
=====
1 - TARGET : ORDERS.O_ORDERDATE, ORDERS.O_TOTALPRICE
2 - JOINED COLUMN : ORDERS.O_ORDERDATE, ORDERS.O_TOTALPRICE
3 - READ COLUMN : ORDERS.O_ORDERKEY, ORDERS.O_TOTALPRICE, ORDERS.O_ORDERDATE
4 - HASH KEY : V6.L_ORDERKEY
   READ KEY COLUMN : V6.L_ORDERKEY
   HASH FILTER : V6.L_ORDERKEY = ORDERS.O_ORDERKEY
   FETCH ONE ROW
5 - COLUMN : LINEITEM.L_ORDERKEY AS L_ORDERKEY
6 - TARGET : LINEITEM.L_ORDERKEY
7 - GROUP KEY : LINEITEM.L_ORDERKEY
   RECORD COLUMN : SUM( LINEITEM.L_QUANTITY )

```

```

      READ KEY COLUMN : LINEITEM.L_ORDERKEY
      READ RECORD COLUMN : SUM( LINEITEM.L_QUANTITY )
      PHYSICAL FILTER : SUM( LINEITEM.L_QUANTITY ) > 300
8 - READ COLUMN : LINEITEM.L_ORDERKEY, LINEITEM.L_QUANTITY
<<< end print plan

```

The execution plan is as same as the example of using UNNEST\_HASH hint, but hash buckets are created in HASH JOIN INSTANT as many as hash bucket count when using the hint above. Therefore, use this hint to adjust hash bucket count if the performance gets slower because hash bucket count is estimated too big or too small while performing cost estimation.

### UNNEST\_HASH\_IN

If UNNEST\_HASH\_IN hint is specified, an optimizer transforms the subquery into the join statement which guarantees the same result, and performs the join by hash join method. Then, it places the subquery which is unnested to a table or a view, on the right of the join.

The following is an example of using UNNEST\_HASH\_IN hint.

```

\EXPLAIN PLAN
SELECT
  o_orderdate,
  o_totalprice
FROM orders
WHERE o_orderkey IN (
  SELECT /*+ UNNEST_HASH_IN */
    l_orderkey
  FROM lineitem
  GROUP BY l_orderkey
  HAVING sum(l_quantity) > 300
)
;
>>> start print plan
< Execution Plan >
=====
|  IDX  |  NODE DESCRIPTION  |
-----|-----|
|   0   |  SELECT STATEMENT  |
|   1   |  QUERY BLOCK ("QB_IDX_2") |
|   2   |  HASH JOIN (INNER JOIN) |
|   3   |  TABLE ACCESS ("ORDERS") |
|   4   |  HASH JOIN INSTANT |
|   5   |  INLINE_VIEW ("V6") |

```



```

| 6 |          QUERY BLOCK ("SQB_IDX_6")          |
| 7 |          GROUP HASH INSTANT                  |
| 8 |          TABLE ACCESS ("LINEITEM")         |
=====
1 - TARGET : ORDERS.O_ORDERDATE, ORDERS.O_TOTALPRICE
2 - JOINED COLUMN : ORDERS.O_ORDERDATE, ORDERS.O_TOTALPRICE
3 - READ COLUMN : ORDERS.O_ORDERKEY, ORDERS.O_TOTALPRICE, ORDERS.O_ORDERDATE
4 - HASH KEY : $V6.L_ORDERKEY
   READ KEY COLUMN : $V6.L_ORDERKEY
   HASH FILTER : $V6.L_ORDERKEY = ORDERS.O_ORDERKEY
   FETCH ONE ROW
5 - COLUMN : LINEITEM.L_ORDERKEY AS L_ORDERKEY
6 - TARGET : LINEITEM.L_ORDERKEY
7 - GROUP KEY : LINEITEM.L_ORDERKEY
   RECORD COLUMN : SUM( LINEITEM.L_QUANTITY )
   READ KEY COLUMN : LINEITEM.L_ORDERKEY
   READ RECORD COLUMN : SUM( LINEITEM.L_QUANTITY )
   PHYSICAL FILTER : SUM( LINEITEM.L_QUANTITY ) > 300
8 - READ COLUMN : LINEITEM.L_ORDERKEY, LINEITEM.L_QUANTITY
<<< end print plan

```

In the example above, a subquery is unnested to `INLINE_VIEW ("V4")`, becomes a right child of `NESTED JOIN` and participates in the join.

### **UNNEST\_HASH\_IN(hash\_bucket\_count)**

`UNNEST_HASH_IN(hash_bucket_count)` hint is as same as `UNNEST_HASH_IN` hint, but in addition to that it can specify the hash bucket count.

Therefore, if `UNNEST_HASH_IN(hash_bucket_count)` hint is used, then it creates hash buckets as many as `hash_bucket_count`.

The following is an example of using `UNNEST_HASH_IN(hash_bucket_count)` hint.

```

\EXPLAIN PLAN
SELECT
    o_orderdate,
    o_totalprice
FROM orders
WHERE o_orderkey IN (
    SELECT /*+ UNNEST_HASH_IN(3) */
        l_orderkey
    FROM lineitem

```

```

        GROUP BY l_orderkey
        HAVING sum(l_quantity) > 300
    )
;
>>> start print plan
< Execution Plan >
=====
|  IDX  |  NODE DESCRIPTION                                |
-----|-----|
|   0   |  SELECT STATEMENT                                |
|   1   |    QUERY BLOCK ("QB_IDX_2")                      |
|   2   |      HASH JOIN (INNER JOIN)                      |
|   3   |        TABLE ACCESS ("ORDERS")                  |
|   4   |          HASH JOIN INSTANT                        |
|   5   |            INLINE_VIEW ("V6")                    |
|   6   |              QUERY BLOCK ("QB_IDX_6")            |
|   7   |                GROUP HASH INSTANT                |
|   8   |                  TABLE ACCESS ("LINEITEM")      |
=====
1 - TARGET : ORDERS.O_ORDERDATE, ORDERS.O_TOTALPRICE
2 - JOINED COLUMN : ORDERS.O_ORDERDATE, ORDERS.O_TOTALPRICE
3 - READ COLUMN : ORDERS.O_ORDERKEY, ORDERS.O_TOTALPRICE, ORDERS.O_ORDERDATE
4 - HASH KEY : V6.L_ORDERKEY
   READ KEY COLUMN : V6.L_ORDERKEY
   HASH FILTER : V6.L_ORDERKEY = ORDERS.O_ORDERKEY
   FETCH ONE ROW
5 - COLUMN : LINEITEM.L_ORDERKEY AS L_ORDERKEY
6 - TARGET : LINEITEM.L_ORDERKEY
7 - GROUP KEY : LINEITEM.L_ORDERKEY
   RECORD COLUMN : SUM( LINEITEM.L_QUANTITY )
   READ KEY COLUMN : LINEITEM.L_ORDERKEY
   READ RECORD COLUMN : SUM( LINEITEM.L_QUANTITY )
   PHYSICAL FILTER : SUM( LINEITEM.L_QUANTITY ) > 300
8 - READ COLUMN : LINEITEM.L_ORDERKEY, LINEITEM.L_QUANTITY
<<< end print plan

```

The execution plan is as same as the example of using UNNEST\_HASH\_IN hint, but hash buckets are created in HASH JOIN INSTANT as many as hash bucket count when using the hint above. Therefore, use this hint to adjust hash bucket count if the performance gets slower because hash bucket count is estimated too big or too small while performing cost estimation.

## UNNEST\_HASH\_OUT

If UNNEST\_HASH\_OUT hint is specified, an optimizer transforms the subquery into the join statement which guarantees the same result, and performs the join by hash join method. Then, it places the subquery which is unnested to a table or a view, on the left of the join.

The following is an example of using UNNEST\_HASH\_OUT hint.

```
\EXPLAIN PLAN
SELECT
    o_orderdate,
    o_totalprice
FROM orders
WHERE o_orderkey IN (
    SELECT /*+ UNNEST_HASH_OUT */
        l_orderkey
    FROM lineitem
    GROUP BY l_orderkey
    HAVING sum(l_quantity) > 300
)
;
>>> start print plan
< Execution Plan >
=====
|  IDX  |  NODE DESCRIPTION  |
-----|-----|
|   0   |  SELECT STATEMENT  |
|   1   |    QUERY BLOCK ("QB_IDX_2")  |
|   2   |      HASH JOIN (INNER JOIN)  |
|   3   |        INLINE_VIEW ("V4")  |
|   4   |          QUERY BLOCK ("QB_IDX_6")  |
|   5   |            GROUP HASH INSTANT  |
|   6   |              TABLE ACCESS ("LINEITEM")  |
|   7   |                HASH JOIN INSTANT  |
|   8   |                  TABLE ACCESS ("ORDERS")  |
=====
1 - TARGET : ORDERS.O_ORDERDATE, ORDERS.O_TOTALPRICE
2 - JOINED COLUMN : ORDERS.O_ORDERDATE, ORDERS.O_TOTALPRICE
3 - COLUMN : LINEITEM.L_ORDERKEY AS L_ORDERKEY
4 - TARGET : LINEITEM.L_ORDERKEY
5 - GROUP KEY : LINEITEM.L_ORDERKEY
   RECORD COLUMN : SUM( LINEITEM.L_QUANTITY )
```

```

      READ KEY COLUMN : LINEITEM.L_ORDERKEY
      READ RECORD COLUMN : SUM( LINEITEM.L_QUANTITY )
      PHYSICAL FILTER : SUM( LINEITEM.L_QUANTITY ) > 300
6 - READ COLUMN : LINEITEM.L_ORDERKEY, LINEITEM.L_QUANTITY
7 - HASH KEY : ORDERS.O_ORDERKEY
      RECORD COLUMN : ORDERS.O_ORDERDATE, ORDERS.O_TOTALPRICE
      READ KEY COLUMN : ORDERS.O_ORDERKEY, ORDERS.O_ORDERDATE, ORDERS.O_TOTALPRICE
      HASH FILTER : ORDERS.O_ORDERKEY = $V4.L_ORDERKEY
      FETCH ONE ROW
8 - READ COLUMN : ORDERS.O_ORDERKEY, ORDERS.O_TOTALPRICE, ORDERS.O_ORDERDATE
<<< end print plan

```

In the example above, a subquery is unnested to `INLINE_VIEW` ("V4"), becomes a left child of `HASH JOIN` and participates in the join.

### **UNNEST\_HASH\_OUT( hash\_bucket\_count )**

`UNNEST_HASH_OUT(hash_bucket_count)` hint is as same as `UNNEST_HASH_OUT` hint, but in addition to that it can specify the hash bucket count.

Therefore, if `UNNEST_HASH_OUT(hash_bucket_count)` hint is used, then it creates hash buckets as many as `hash_bucket_count`.

The following is an example of using `UNNEST_HASH_OUT(hash_bucket_count)` hint.

```

\EXPLAIN PLAN
SELECT
    o_orderdate,
    o_totalprice
FROM orders
WHERE o_orderkey IN (
    SELECT /*+ UNNEST_HASH_OUT(3) */
        l_orderkey
    FROM lineitem
    GROUP BY l_orderkey
    HAVING sum(l_quantity) > 300
)
;
>>> start print plan
< Execution Plan >
=====
|  IDX  |  NODE DESCRIPTION  |
-----

```

```

| 0 | SELECT STATEMENT |
| 1 |   QUERY BLOCK ("QB_IDX_2") |
| 2 |     HASH JOIN (INNER JOIN) |
| 3 |       INLINE_VIEW ("V4") |
| 4 |         QUERY BLOCK ("QB_IDX_6") |
| 5 |           GROUP HASH INSTANT |
| 6 |             TABLE ACCESS ("LINEITEM") |
| 7 |               HASH JOIN INSTANT |
| 8 |                 TABLE ACCESS ("ORDERS") |
=====
1 - TARGET : ORDERS.O_ORDERDATE, ORDERS.O_TOTALPRICE
2 - JOINED COLUMN : ORDERS.O_ORDERDATE, ORDERS.O_TOTALPRICE
3 - COLUMN : LINEITEM.L_ORDERKEY AS L_ORDERKEY
4 - TARGET : LINEITEM.L_ORDERKEY
5 - GROUP KEY : LINEITEM.L_ORDERKEY
   RECORD COLUMN : SUM( LINEITEM.L_QUANTITY )
   READ KEY COLUMN : LINEITEM.L_ORDERKEY
   READ RECORD COLUMN : SUM( LINEITEM.L_QUANTITY )
   PHYSICAL FILTER : SUM( LINEITEM.L_QUANTITY ) > 300
6 - READ COLUMN : LINEITEM.L_ORDERKEY, LINEITEM.L_QUANTITY
7 - HASH KEY : ORDERS.O_ORDERKEY
   RECORD COLUMN : ORDERS.O_ORDERDATE, ORDERS.O_TOTALPRICE
   READ KEY COLUMN : ORDERS.O_ORDERKEY, ORDERS.O_ORDERDATE, ORDERS.O_TOTALPRICE
   HASH FILTER : ORDERS.O_ORDERKEY = V4.L_ORDERKEY
   FETCH ONE ROW
8 - READ COLUMN : ORDERS.O_ORDERKEY, ORDERS.O_TOTALPRICE, ORDERS.O_ORDERDATE
<<< end print plan

```

The execution plan is as same as the example of using UNNEST\_HASH\_OUT hint, but hash buckets are created in HASH JOIN INSTANT as many as hash bucket count when using the hint above. Therefore, use this hint to adjust hash bucket count if the performance gets slower because hash bucket count is estimated too big or too small while performing cost estimation.

## UNNEST\_MERGE

If UNNEST\_MERGE hint is specified, an optimizer transforms the subquery into the join statement which guarantees the same result, and performs the join by merge join method.

The following is an example of using UNNEST\_MERGE hint.

```

\EXPLAIN PLAN
SELECT
    o_orderdate,

```

```

        o_totalprice
FROM orders
WHERE o_orderkey IN (
                SELECT /*+ UNNEST_MERGE */
                   l_orderkey
                FROM   lineitem
                GROUP BY l_orderkey
                HAVING  sum(l_quantity) > 300
            )
;
>>> start print plan
< Execution Plan >
=====
|  IDX  |  NODE DESCRIPTION                                |
-----|-----|
|   0   |  SELECT STATEMENT                                |
|   1   |    QUERY BLOCK ("QB_IDX_2")                      |
|   2   |      MERGE JOIN (INNER JOIN)                    |
|   3   |        INDEX ACCESS ("ORDERS", "ORDERS_PK_INDEX") |
|   4   |          SORT JOIN INSTANT                       |
|   5   |            INLINE_VIEW ("V6")                   |
|   6   |              QUERY BLOCK ("QB_IDX_6")           |
|   7   |                GROUP HASH INSTANT               |
|   8   |                  TABLE ACCESS ("LINEITEM")     |
=====
1 - TARGET : ORDERS.O_ORDERDATE, ORDERS.O_TOTALPRICE
2 - JOINED COLUMN : ORDERS.O_ORDERDATE, ORDERS.O_TOTALPRICE
   ON FILTER (Equi) : ORDERS.O_ORDERKEY = V6.L_ORDERKEY
3 - READ INDEX COLUMN : ORDERS.O_ORDERKEY
   READ TABLE COLUMN : ORDERS.O_TOTALPRICE, ORDERS.O_ORDERDATE
4 - SORT KEY : "V6.L_ORDERKEY ASC NULLS LAST"
   READ KEY COLUMN : V6.L_ORDERKEY
   MIN RANGE : V6.L_ORDERKEY >= {ORDERS.O_ORDERKEY}
   MAX RANGE : V6.L_ORDERKEY IS NOT NULL
5 - COLUMN : LINEITEM.L_ORDERKEY AS L_ORDERKEY
6 - TARGET : LINEITEM.L_ORDERKEY
7 - GROUP KEY : LINEITEM.L_ORDERKEY
   RECORD COLUMN : SUM( LINEITEM.L_QUANTITY )
   READ KEY COLUMN : LINEITEM.L_ORDERKEY
   READ RECORD COLUMN : SUM( LINEITEM.L_QUANTITY )
   PHYSICAL FILTER : SUM( LINEITEM.L_QUANTITY ) > 300

```

```

      8 - READ COLUMN : LINEITEM.L_ORDERKEY, LINEITEM.L_QUANTITY
<<< end print plan

```

In the example above, a subquery is unnested to `INLINE_VIEW ("V6")`, and participates in `MERGE JOIN`.

### UNNEST\_MERGE\_IN

If `UNNEST_MERGE_IN` hint is specified, an optimizer transforms the subquery into the join statement which guarantees the same result, and performs the join by merge join method. Then, it places the subquery which is unnested to a table or a view, on the right of the join.

The following is an example of using `UNNEST_MERGE_IN` hint.

```

\EXPLAIN PLAN
SELECT
    o_orderdate,
    o_totalprice
FROM orders
WHERE o_orderkey IN (
    SELECT /*+ UNNEST_MERGE_IN */
        l_orderkey
    FROM lineitem
    GROUP BY l_orderkey
    HAVING sum(l_quantity) > 300
)
;
>>> start print plan
< Execution Plan >
=====
|  IDX  |  NODE DESCRIPTION  |
-----|-----|
|   0   |  SELECT STATEMENT  |
|   1   |  QUERY BLOCK ("QB_IDX_2") |
|   2   |  MERGE JOIN (INNER JOIN) |
|   3   |  INDEX ACCESS ("ORDERS", "ORDERS_PK_INDEX") |
|   4   |  SORT JOIN INSTANT |
|   5   |  INLINE_VIEW ("V6") |
|   6   |  QUERY BLOCK ("QB_IDX_6") |
|   7   |  GROUP HASH INSTANT |
|   8   |  TABLE ACCESS ("LINEITEM") |
=====
1 - TARGET : ORDERS.O_ORDERDATE, ORDERS.O_TOTALPRICE
2 - JOINED COLUMN : ORDERS.O_ORDERDATE, ORDERS.O_TOTALPRICE

```

```

        ON FILTER (Equi) : ORDERS.O_ORDERKEY = $V6.L_ORDERKEY
3  -  READ INDEX COLUMN : ORDERS.O_ORDERKEY
    READ TABLE COLUMN : ORDERS.O_TOTALPRICE, ORDERS.O_ORDERDATE
4  -  SORT KEY : "$V6.L_ORDERKEY ASC NULLS LAST"
    READ KEY COLUMN : $V6.L_ORDERKEY
    MIN RANGE : $V6.L_ORDERKEY >= {ORDERS.O_ORDERKEY}
    MAX RANGE : $V6.L_ORDERKEY IS NOT NULL
5  -  COLUMN : LINEITEM.L_ORDERKEY AS L_ORDERKEY
6  -  TARGET : LINEITEM.L_ORDERKEY
7  -  GROUP KEY : LINEITEM.L_ORDERKEY
    RECORD COLUMN : SUM( LINEITEM.L_QUANTITY )
    READ KEY COLUMN : LINEITEM.L_ORDERKEY
    READ RECORD COLUMN : SUM( LINEITEM.L_QUANTITY )
    PHYSICAL FILTER : SUM( LINEITEM.L_QUANTITY ) > 300
8  -  READ COLUMN : LINEITEM.L_ORDERKEY, LINEITEM.L_QUANTITY
<<< end print plan

```

In the example above, a subquery is unnested to `INLINE_VIEW ("V6")`, becomes a right child of `MERGE JOIN` and participates in the join.

### UNNEST\_MERGE\_OUT

If `UNNEST_MERGE_OUT` hint is specified, an optimizer transforms the subquery into the join statement which guarantees the same result, and performs the join by merge join method. Then, it places the subquery which is unnested to a table or a view, on the left of the join.

The following is an example of using `UNNEST_MERGE_OUT` hint.

```

\EXPLAIN PLAN
SELECT
    o_orderdate,
    o_totalprice
FROM orders
WHERE o_orderkey IN (
    SELECT /*+ UNNEST_MERGE_OUT */
        l_orderkey
    FROM lineitem
    GROUP BY l_orderkey
    HAVING sum(l_quantity) > 300
)
;
>>> start print plan
< Execution Plan >

```



```

=====
|  IDX  |  NODE DESCRIPTION  |
-----
|  0  |  SELECT STATEMENT  |
|  1  |  QUERY BLOCK ("QB_IDX_2")  |
|  2  |  MERGE JOIN (INNER JOIN)  |
|  3  |  SORT JOIN INSTANT  |
|  4  |  INLINE_VIEW ("V5")  |
|  5  |  QUERY BLOCK ("QB_IDX_6")  |
|  6  |  GROUP HASH INSTANT  |
|  7  |  TABLE ACCESS ("LINEITEM")  |
|  8  |  INDEX ACCESS ("ORDERS", "ORDERS_PK_INDEX")  |
=====
1 - TARGET : ORDERS.O_ORDERDATE, ORDERS.O_TOTALPRICE
2 - JOINED COLUMN : ORDERS.O_ORDERDATE, ORDERS.O_TOTALPRICE
   ON FILTER (Equi) : $V5.L_ORDERKEY = ORDERS.O_ORDERKEY
3 - SORT KEY : "$V5.L_ORDERKEY ASC NULLS LAST"
   READ KEY COLUMN : $V5.L_ORDERKEY
4 - COLUMN : LINEITEM.L_ORDERKEY AS L_ORDERKEY
5 - TARGET : LINEITEM.L_ORDERKEY
6 - GROUP KEY : LINEITEM.L_ORDERKEY
   RECORD COLUMN : SUM( LINEITEM.L_QUANTITY )
   READ KEY COLUMN : LINEITEM.L_ORDERKEY
   READ RECORD COLUMN : SUM( LINEITEM.L_QUANTITY )
   PHYSICAL FILTER : SUM( LINEITEM.L_QUANTITY ) > 300
7 - READ COLUMN : LINEITEM.L_ORDERKEY, LINEITEM.L_QUANTITY
8 - READ INDEX COLUMN : ORDERS.O_ORDERKEY
   READ TABLE COLUMN : ORDERS.O_TOTALPRICE, ORDERS.O_ORDERDATE
   MIN RANGE : ORDERS.O_ORDERKEY >= {$V5.L_ORDERKEY}
   MAX RANGE : ORDERS.O_ORDERKEY IS NOT NULL
<<< end print plan

```

In the example above, a subquery is unnested to `INLINE_VIEW ("V5")`, becomes a left child of `MERGE JOIN` and participates in the join.

### NL\_SJ

If `NL_SJ` hint is specified, an optimizer unnests the subquery in semi join form, and performs the semi join in nested loop method.

It is operated in the same way as that of `UNNEST_NL` hint. However, `UNNEST_NL` hint is applied to both semi join and anti-semi join, on the other hand, `NL_SJ` hint is applied only to semi join.

Therefore, if the hint above is specified on a subquery which is unnested with anti-semi join, then an optimizer ignores it.

The following is an example of using NL\_SJ hint.

```
\EXPLAIN PLAN
SELECT
    o_orderdate,
    o_totalprice
FROM orders
WHERE o_orderkey IN (
    SELECT /*+ NL_SJ */
        l_orderkey
    FROM lineitem
    GROUP BY l_orderkey
    HAVING sum(l_quantity) > 300
)
;
>>> start print plan
< Execution Plan >
=====
|  IDX  |  NODE DESCRIPTION          |
-----|-----|
|   0   |  SELECT STATEMENT         |
|   1   |    QUERY BLOCK ("QB_IDX_2") |
|   2   |      NESTED JOIN (INNER JOIN) |
|   3   |        TABLE ACCESS ("ORDERS") |
|   4   |          INLINE_VIEW ("V5") |
|   5   |            QUERY BLOCK ("QB_IDX_6") |
|   6   |              GROUP          |
|   7   |                INDEX ACCESS ("LINEITEM", "LINEITEM_PK_INDEX") |
=====
1 - TARGET : ORDERS.O_ORDERDATE, ORDERS.O_TOTALPRICE
2 - JOINED COLUMN : ORDERS.O_ORDERDATE, ORDERS.O_TOTALPRICE
3 - READ COLUMN : ORDERS.O_ORDERKEY, ORDERS.O_TOTALPRICE, ORDERS.O_ORDERDATE
4 - COLUMN : LINEITEM.L_ORDERKEY AS L_ORDERKEY
5 - TARGET : LINEITEM.L_ORDERKEY
6 - GROUP KEY : LINEITEM.L_ORDERKEY
  RECORD COLUMN : SUM( LINEITEM.L_QUANTITY )
  LOGICAL FILTER : SUM( LINEITEM.L_QUANTITY ) > 300
7 - READ INDEX COLUMN : LINEITEM.L_ORDERKEY
```

```

      READ TABLE COLUMN : LINEITEM.L_QUANTITY
      MIN RANGE : LINEITEM.L_ORDERKEY = {ORDERS.O_ORDERKEY}
      MAX RANGE : LINEITEM.L_ORDERKEY = {ORDERS.O_ORDERKEY}
<<< end print plan

```

In the example above, NL\_SJ hint is applied so a subquery is unnested with semi join and nested loop join is performed. Also, the semi join is converted into an inner join because both o\_orderkey and l\_orderkey are primary keys.

The following is an example of using NL\_SJ hint on a subquery which can be unnested only in anti-semi join form.

```

\EXPLAIN PLAN
SELECT
    o_orderdate,
    o_totalprice
FROM orders
WHERE o_orderkey NOT IN (
    SELECT /*+ NL_SJ */
        l_orderkey
    FROM lineitem
    GROUP BY l_orderkey
    HAVING sum(l_quantity) > 300
)
;
>>> start print plan
< Execution Plan >
=====
|  IDX  |  NODE DESCRIPTION  |
-----|-----|
|   0   |  SELECT STATEMENT  |
|   1   |  QUERY BLOCK ("QB_IDX_2") |
|   2   |    HASH JOIN (ANTI SEMI) |
|   3   |      TABLE ACCESS ("ORDERS") |
|   4   |      HASH JOIN INSTANT (UNIQUE) |
|   5   |        INLINE_VIEW ("V6") |
|   6   |        QUERY BLOCK ("QB_IDX_6") |
|   7   |          GROUP HASH INSTANT |
|   8   |          TABLE ACCESS ("LINEITEM") |
=====
1 - TARGET : ORDERS.O_ORDERDATE, ORDERS.O_TOTALPRICE
2 - JOINED COLUMN : ORDERS.O_ORDERDATE, ORDERS.O_TOTALPRICE

```

```

3 - READ COLUMN : ORDERS.O_ORDERKEY, ORDERS.O_TOTALPRICE, ORDERS.O_ORDERDATE
4 - HASH KEY : $V6.L_ORDERKEY
  READ KEY COLUMN : $V6.L_ORDERKEY
  HASH FILTER : $V6.L_ORDERKEY = ORDERS.O_ORDERKEY
  FETCH ONE ROW
5 - COLUMN : LINEITEM.L_ORDERKEY AS L_ORDERKEY
6 - TARGET : LINEITEM.L_ORDERKEY
7 - GROUP KEY : LINEITEM.L_ORDERKEY
  RECORD COLUMN : SUM( LINEITEM.L_QUANTITY )
  READ KEY COLUMN : LINEITEM.L_ORDERKEY
  READ RECORD COLUMN : SUM( LINEITEM.L_QUANTITY )
  PHYSICAL FILTER : SUM( LINEITEM.L_QUANTITY ) > 300
8 - READ COLUMN : LINEITEM.L_ORDERKEY, LINEITEM.L_QUANTITY
<<< end print plan

```

The hint is ignored so it is unnested by anti-semi join method, then performed in hash join method.

### NL\_ISJ

If NL\_ISJ hint is specified, an optimizer unnests the subquery in inverted semi join form, and performs the semi join in nested loop method. Then, it places the subquery which is unnested to a table or a view, on the left of the join because it is an inverted semi join.

It is operated in the same way as that of UNNEST\_NL\_OUT hint. However, UNNEST\_NL\_OUT hint is applied to both semi join and anti-semi join, on the other hand, NL\_ISJ hint is applied only to semi join.

Therefore, if the hint above is specified on a subquery which is unnested with anti-semi join, then an optimizer ignores it.

The following is an example of using NL\_ISJ hint.

```

\EXPLAIN PLAN
SELECT
  o_orderdate,
  o_totalprice
FROM orders
WHERE o_orderkey IN (
  SELECT /*+ NL_ISJ */
    l_orderkey
  FROM lineitem
  GROUP BY l_orderkey
  HAVING sum(l_quantity) > 300
)
;

```

```

>>> start print plan
< Execution Plan >
=====
|  IDX  |  NODE DESCRIPTION          |
-----|-----|
|   0   |  SELECT STATEMENT         |
|   1   |    QUERY BLOCK ("QB_IDX_2") |
|   2   |      NESTED JOIN (INNER JOIN) |
|   3   |        INLINE_VIEW ("V4")   |
|   4   |          QUERY BLOCK ("QB_IDX_6") |
|   5   |            GROUP HASH INSTANT |
|   6   |              TABLE ACCESS ("LINEITEM") |
|   7   |                INDEX ACCESS ("ORDERS", "ORDERS_PK_INDEX") |
=====
1 - TARGET : ORDERS.O_ORDERDATE, ORDERS.O_TOTALPRICE
2 - JOINED COLUMN : ORDERS.O_ORDERDATE, ORDERS.O_TOTALPRICE
3 - COLUMN : LINEITEM.L_ORDERKEY AS L_ORDERKEY
4 - TARGET : LINEITEM.L_ORDERKEY
5 - GROUP KEY : LINEITEM.L_ORDERKEY
   RECORD COLUMN : SUM( LINEITEM.L_QUANTITY )
   READ KEY COLUMN : LINEITEM.L_ORDERKEY
   READ RECORD COLUMN : SUM( LINEITEM.L_QUANTITY )
   PHYSICAL FILTER : SUM( LINEITEM.L_QUANTITY ) > 300
6 - READ COLUMN : LINEITEM.L_ORDERKEY, LINEITEM.L_QUANTITY
7 - READ INDEX COLUMN : ORDERS.O_ORDERKEY
   READ TABLE COLUMN : ORDERS.O_TOTALPRICE, ORDERS.O_ORDERDATE
   MIN RANGE : ORDERS.O_ORDERKEY = {V4.L_ORDERKEY}
   MAX RANGE : ORDERS.O_ORDERKEY = {V4.L_ORDERKEY}
   FETCH ONE ROW
<<< end print plan

```

In the example above, NL\_ISJ hint is applied so a subquery is unnested with inverted semi join and nested loop join is performed. Also, the semi join is converted into an inner join because both o\_orderkey and l\_orderkey are primary keys.

The following is an example of using NL\_ISJ hint in a subquery which can be unnested only in anti-semi join form.

```

\EXPLAIN PLAN
SELECT
    o_orderdate,
    o_totalprice

```

```

FROM orders
WHERE o_orderkey NOT IN (
        SELECT /*+ NL_ISJ */
            l_orderkey
        FROM lineitem
        GROUP BY l_orderkey
        HAVING sum(l_quantity) > 300
    )

```

```
;
```

```
>>> start print plan
```

```
< Execution Plan >
```

```

=====
|  IDX  |  NODE DESCRIPTION                                |
-----
|   0   |  SELECT STATEMENT                                |
|   1   |    QUERY BLOCK ("SQB_IDX_2")                    |
|   2   |      HASH JOIN (ANTI SEMI)                      |
|   3   |        TABLE ACCESS ("ORDERS")                 |
|   4   |          HASH JOIN INSTANT (UNIQUE)             |
|   5   |            INLINE_VIEW ("V6")                  |
|   6   |              QUERY BLOCK ("SQB_IDX_6")         |
|   7   |                GROUP HASH INSTANT              |
|   8   |                  TABLE ACCESS ("LINEITEM")    |
=====

```

```

1 - TARGET : ORDERS.O_ORDERDATE, ORDERS.O_TOTALPRICE
2 - JOINED COLUMN : ORDERS.O_ORDERDATE, ORDERS.O_TOTALPRICE
3 - READ COLUMN : ORDERS.O_ORDERKEY, ORDERS.O_TOTALPRICE, ORDERS.O_ORDERDATE
4 - HASH KEY : V6.L_ORDERKEY
   READ KEY COLUMN : V6.L_ORDERKEY
   HASH FILTER : V6.L_ORDERKEY = ORDERS.O_ORDERKEY
   FETCH ONE ROW
5 - COLUMN : LINEITEM.L_ORDERKEY AS L_ORDERKEY
6 - TARGET : LINEITEM.L_ORDERKEY
7 - GROUP KEY : LINEITEM.L_ORDERKEY
   RECORD COLUMN : SUM( LINEITEM.L_QUANTITY )
   READ KEY COLUMN : LINEITEM.L_ORDERKEY
   READ RECORD COLUMN : SUM( LINEITEM.L_QUANTITY )
   PHYSICAL FILTER : SUM( LINEITEM.L_QUANTITY ) > 300
8 - READ COLUMN : LINEITEM.L_ORDERKEY, LINEITEM.L_QUANTITY

```

```
<<< end print plan
```

The hint is ignored so it is unnested by anti-semi join method, performed in hash join method, and the unnested subquery is located on the right.

## INL\_SJ

If INL\_SJ hint is specified, an optimizer unnests the subquery in semi join form, and performs the semi join in instant nested loop method.

It is operated in the same way as that of UNNEST\_INL hint. However, UNNEST\_INL hint is applied to both semi join and anti-semi join, on the other hand, INL\_SJ hint is applied only to semi join. Therefore, if the hint above is specified on a subquery which is unnested with anti-semi join, then an optimizer ignores it.

The following is an example of using INL\_SJ hint.

```
\EXPLAIN PLAN
SELECT
    o_orderdate,
    o_totalprice
FROM orders
WHERE o_orderkey IN (
    SELECT /*+ INL_SJ */
        l_orderkey
    FROM lineitem
    GROUP BY l_orderkey
    HAVING sum(l_quantity) > 300
)
;
>>> start print plan
< Execution Plan >
```

IDX	NODE DESCRIPTION
0	SELECT STATEMENT
1	QUERY BLOCK ("SQB_IDX_2")
2	NESTED JOIN (INNER JOIN)
3	TABLE ACCESS ("ORDERS")
4	SORT JOIN INSTANT
5	INLINE_VIEW ("V6")
6	QUERY BLOCK ("SQB_IDX_6")
7	GROUP HASH INSTANT
8	TABLE ACCESS ("LINEITEM")

```
1 - TARGET : ORDERS.O_ORDERDATE, ORDERS.O_TOTALPRICE
```

```

2 - JOINED COLUMN : ORDERS.O_ORDERDATE, ORDERS.O_TOTALPRICE
3 - READ COLUMN : ORDERS.O_ORDERKEY, ORDERS.O_TOTALPRICE, ORDERS.O_ORDERDATE
4 - SORT KEY : "$V6.L_ORDERKEY ASC NULLS LAST"
   READ KEY COLUMN : $V6.L_ORDERKEY
     MIN RANGE : $V6.L_ORDERKEY = {ORDERS.O_ORDERKEY}
     MAX RANGE : $V6.L_ORDERKEY = {ORDERS.O_ORDERKEY}
5 - COLUMN : LINEITEM.L_ORDERKEY AS L_ORDERKEY
6 - TARGET : LINEITEM.L_ORDERKEY
7 - GROUP KEY : LINEITEM.L_ORDERKEY
   RECORD COLUMN : SUM( LINEITEM.L_QUANTITY )
   READ KEY COLUMN : LINEITEM.L_ORDERKEY
   READ RECORD COLUMN : SUM( LINEITEM.L_QUANTITY )
     PHYSICAL FILTER : SUM( LINEITEM.L_QUANTITY ) > 300
8 - READ COLUMN : LINEITEM.L_ORDERKEY, LINEITEM.L_QUANTITY

```

```
<<< end print plan
```

In the example above, INL\_SJ hint is applied so a subquery is unnested with semi join and instant nested loop join is performed. Also, the semi join is converted into an inner join because both o\_orderkey and l\_orderkey are primary keys.

The following is an example of using INL\_SJ hint in a subquery which can be unnested only in anti-semi join form.

```

\EXPLAIN PLAN
SELECT
    o_orderdate,
    o_totalprice
FROM orders
WHERE o_orderkey NOT IN (
    SELECT /*+ INL_SJ */
        l_orderkey
    FROM lineitem
    GROUP BY l_orderkey
    HAVING sum(l_quantity) > 300
)
;
>>> start print plan
< Execution Plan >
=====
|  IDX  |  NODE DESCRIPTION  |
-----|-----|
|      0 | SELECT STATEMENT   |

```



```

| 1 | QUERY BLOCK ("QB_IDX_2") |
| 2 | HASH JOIN (ANTI SEMI) |
| 3 | TABLE ACCESS ("ORDERS") |
| 4 | HASH JOIN INSTANT (UNIQUE) |
| 5 | INLINE_VIEW ("V6") |
| 6 | QUERY BLOCK ("QB_IDX_6") |
| 7 | GROUP HASH INSTANT |
| 8 | TABLE ACCESS ("LINEITEM") |
=====
1 - TARGET : ORDERS.O_ORDERDATE, ORDERS.O_TOTALPRICE
2 - JOINED COLUMN : ORDERS.O_ORDERDATE, ORDERS.O_TOTALPRICE
3 - READ COLUMN : ORDERS.O_ORDERKEY, ORDERS.O_TOTALPRICE, ORDERS.O_ORDERDATE
4 - HASH KEY : V6.L_ORDERKEY
   READ KEY COLUMN : V6.L_ORDERKEY
   HASH FILTER : V6.L_ORDERKEY = ORDERS.O_ORDERKEY
   FETCH ONE ROW
5 - COLUMN : LINEITEM.L_ORDERKEY AS L_ORDERKEY
6 - TARGET : LINEITEM.L_ORDERKEY
7 - GROUP KEY : LINEITEM.L_ORDERKEY
   RECORD COLUMN : SUM( LINEITEM.L_QUANTITY )
   READ KEY COLUMN : LINEITEM.L_ORDERKEY
   READ RECORD COLUMN : SUM( LINEITEM.L_QUANTITY )
   PHYSICAL FILTER : SUM( LINEITEM.L_QUANTITY ) > 300
8 - READ COLUMN : LINEITEM.L_ORDERKEY, LINEITEM.L_QUANTITY
<<< end print plan

```

The hint is ignored so it is unnested by anti-semi join method, then performed in hash join method.

## MERGE\_SJ

If MERGE\_SJ hint is specified, an optimizer unnests the subquery in semi join form, and performs the semi join in merge join method.

It is operated in the same way as that of UNNEST\_MERGE hint. However, UNNEST\_MERGE hint is applied to both semi join and anti-semi join, on the other hand, MERGE\_SJ hint is applied only to semi join.

Therefore, if the hint above is specified on a subquery which is unnested with anti-semi join, then an optimizer ignores it.

The following is an example of using MERGE\_SJ hint.

```

\EXPLAIN PLAN
SELECT
    o_orderdate,

```

```

        o_totalprice
FROM orders
WHERE o_orderkey IN (
                SELECT /*+ MERGE_SJ */
                   l_orderkey
                FROM   lineitem
                GROUP BY l_orderkey
                HAVING  sum(l_quantity) > 300
                )
;
>>> start print plan
< Execution Plan >
=====
|  IDX  |  NODE DESCRIPTION                                |
-----|-----|
|   0   |  SELECT STATEMENT                                |
|   1   |    QUERY BLOCK ("QB_IDX_2")                      |
|   2   |      MERGE JOIN (INNER JOIN)                     |
|   3   |        INDEX ACCESS ("ORDERS", "ORDERS_PK_INDEX") |
|   4   |          SORT JOIN INSTANT                        |
|   5   |            INLINE_VIEW ("V6")                    |
|   6   |              QUERY BLOCK ("QB_IDX_6")            |
|   7   |                GROUP HASH INSTANT                |
|   8   |                  TABLE ACCESS ("LINEITEM")      |
=====
1 - TARGET : ORDERS.O_ORDERDATE, ORDERS.O_TOTALPRICE
2 - JOINED COLUMN : ORDERS.O_ORDERDATE, ORDERS.O_TOTALPRICE
   ON FILTER (Equi) : ORDERS.O_ORDERKEY = V6.L_ORDERKEY
3 - READ INDEX COLUMN : ORDERS.O_ORDERKEY
   READ TABLE COLUMN : ORDERS.O_TOTALPRICE, ORDERS.O_ORDERDATE
4 - SORT KEY : "V6.L_ORDERKEY ASC NULLS LAST"
   READ KEY COLUMN : V6.L_ORDERKEY
   MIN RANGE : V6.L_ORDERKEY >= {ORDERS.O_ORDERKEY}
   MAX RANGE : V6.L_ORDERKEY IS NOT NULL
5 - COLUMN : LINEITEM.L_ORDERKEY AS L_ORDERKEY
6 - TARGET : LINEITEM.L_ORDERKEY
7 - GROUP KEY : LINEITEM.L_ORDERKEY
   RECORD COLUMN : SUM( LINEITEM.L_QUANTITY )
   READ KEY COLUMN : LINEITEM.L_ORDERKEY
   READ RECORD COLUMN : SUM( LINEITEM.L_QUANTITY )
   PHYSICAL FILTER : SUM( LINEITEM.L_QUANTITY ) > 300

```

```

      8 - READ COLUMN : LINEITEM.L_ORDERKEY, LINEITEM.L_QUANTITY
<<< end print plan

```

In the example above, MERGE\_SJ hint is applied so a subquery is unnested with semi join and merge join is performed. Also, the semi join is converted into an inner join because both o\_orderkey and l\_orderkey are primary keys.

The following is an example of using MERGE\_SJ hint in a subquery which can be unnested only in anti-semi join form.

```

\EXPLAIN PLAN
SELECT
    o_orderdate,
    o_totalprice
FROM orders
WHERE o_orderkey NOT IN (
    SELECT /*+ MERGE_SJ */
        l_orderkey
    FROM lineitem
    GROUP BY l_orderkey
    HAVING sum(l_quantity) > 300
)
;
>>> start print plan
< Execution Plan >
=====
|  IDX  |  NODE DESCRIPTION  |
-----|-----|
|   0   |  SELECT STATEMENT  |
|   1   |    QUERY BLOCK ("QB_IDX_2")  |
|   2   |      HASH JOIN (ANTI SEMI)  |
|   3   |        TABLE ACCESS ("ORDERS")  |
|   4   |        HASH JOIN INSTANT (UNIQUE)  |
|   5   |          INLINE_VIEW ("V6")  |
|   6   |          QUERY BLOCK ("QB_IDX_6")  |
|   7   |            GROUP HASH INSTANT  |
|   8   |            TABLE ACCESS ("LINEITEM")  |
=====
1 - TARGET : ORDERS.O_ORDERDATE, ORDERS.O_TOTALPRICE
2 - JOINED COLUMN : ORDERS.O_ORDERDATE, ORDERS.O_TOTALPRICE
3 - READ COLUMN : ORDERS.O_ORDERKEY, ORDERS.O_TOTALPRICE, ORDERS.O_ORDERDATE
4 - HASH KEY : V6.L_ORDERKEY

```

```

        READ KEY COLUMN : $V6.L_ORDERKEY
        HASH FILTER : $V6.L_ORDERKEY = ORDERS.O_ORDERKEY
        FETCH ONE ROW
5  - COLUMN : LINEITEM.L_ORDERKEY AS L_ORDERKEY
6  - TARGET : LINEITEM.L_ORDERKEY
7  - GROUP KEY : LINEITEM.L_ORDERKEY
        RECORD COLUMN : SUM( LINEITEM.L_QUANTITY )
        READ KEY COLUMN : LINEITEM.L_ORDERKEY
        READ RECORD COLUMN : SUM( LINEITEM.L_QUANTITY )
        PHYSICAL FILTER : SUM( LINEITEM.L_QUANTITY ) > 300
8  - READ COLUMN : LINEITEM.L_ORDERKEY, LINEITEM.L_QUANTITY
<<< end print plan

```

The hint is ignored so it is unnested by anti-semi join method, then performed in hash join method.

## HASH\_SJ

If HASH\_SJ hint is specified, an optimizer unnests the subquery in semi join form, and performs the semi join in hash join method.

It is operated in the same way as that of UNNEST\_HASH hint. However, UNNEST\_HASH hint is applied to both semi join and anti-semi join, on the other hand, HASH\_SJ hint is applied only to semi join. Therefore, if the hint above is specified on a subquery which is unnested with anti-semi join, then an optimizer ignores it.

The following is an example of using HASH\_SJ hint.

```

\EXPLAIN PLAN
SELECT
    o_orderdate,
    o_totalprice
FROM orders
WHERE o_orderkey IN (
        SELECT /*+ HASH_SJ */
            l_orderkey
        FROM lineitem
        GROUP BY l_orderkey
        HAVING sum(l_quantity) > 300
    )
;
no rows selected.
>>> start print plan
< Execution Plan >

```

```

=====
|  IDX  |  NODE DESCRIPTION  |
-----
|  0  |  SELECT STATEMENT  |
|  1  |    QUERY BLOCK ("QB_IDX_2")  |
|  2  |      HASH JOIN (INNER JOIN)  |
|  3  |        TABLE ACCESS ("ORDERS")  |
|  4  |          HASH JOIN INSTANT  |
|  5  |            INLINE_VIEW ("V6")  |
|  6  |              QUERY BLOCK ("QB_IDX_6")  |
|  7  |                GROUP HASH INSTANT  |
|  8  |                  TABLE ACCESS ("LINEITEM")  |
=====
1 - TARGET : ORDERS.O_ORDERDATE, ORDERS.O_TOTALPRICE
2 - JOINED COLUMN : ORDERS.O_ORDERDATE, ORDERS.O_TOTALPRICE
3 - READ COLUMN : ORDERS.O_ORDERKEY, ORDERS.O_TOTALPRICE, ORDERS.O_ORDERDATE
4 - HASH KEY : V6.L_ORDERKEY
   READ KEY COLUMN : V6.L_ORDERKEY
   HASH FILTER : V6.L_ORDERKEY = ORDERS.O_ORDERKEY
   FETCH ONE ROW
5 - COLUMN : LINEITEM.L_ORDERKEY AS L_ORDERKEY
6 - TARGET : LINEITEM.L_ORDERKEY
7 - GROUP KEY : LINEITEM.L_ORDERKEY
   RECORD COLUMN : SUM( LINEITEM.L_QUANTITY )
   READ KEY COLUMN : LINEITEM.L_ORDERKEY
   READ RECORD COLUMN : SUM( LINEITEM.L_QUANTITY )
   PHYSICAL FILTER : SUM( LINEITEM.L_QUANTITY ) > 300
8 - READ COLUMN : LINEITEM.L_ORDERKEY, LINEITEM.L_QUANTITY
<<< end print plan

```

In the example above, HASH\_SJ hint is applied so a subquery is unnested with semi join and hash join is performed. Also, the semi join is converted into an inner join because both o\_orderkey and l\_orderkey are primary keys.

The following is an example of using HASH\_SJ hint in a subquery which can be unnested only in anti-semi join form.

```

\EXPLAIN PLAN
SELECT
    o_orderdate,
    o_totalprice
FROM orders

```

```

WHERE o_orderkey NOT IN (
    SELECT /*+ HASH_SJ */
           l_orderkey
    FROM   lineitem
    WHERE  l_shipdate >= date '1996-01-01'
           AND l_shipdate < date '1996-02-01'
           AND l_commitdate < l_receiptdate
    GROUP BY l_orderkey
    HAVING sum(l_quantity) > 300
)
AND o_orderdate >= date '1996-01-01'
AND o_orderdate < date '1996-02-01'
AND o_comment like '%Customer%Complaints%'
AND o_orderstatus = 'F'
;
>>> start print plan
< Execution Plan >
=====
|  IDX  |  NODE DESCRIPTION  |
-----|-----|
|   0   |  SELECT STATEMENT  |
|   1   |    QUERY BLOCK ("QB_IDX_2")  |
|   2   |      NESTED JOIN (ANTI SEMI)  |
|   3   |        TABLE ACCESS ("ORDERS")  |
|   4   |          INLINE_VIEW ("V5")  |
|   5   |            QUERY BLOCK ("QB_IDX_6")  |
|   6   |              GROUP  |
|   7   |                INDEX ACCESS ("LINEITEM", "LINEITEM_PK_INDEX")  |
=====
1 - TARGET : ORDERS.O_ORDERDATE, ORDERS.O_TOTALPRICE
2 - JOINED COLUMN : ORDERS.O_ORDERDATE, ORDERS.O_TOTALPRICE
3 - READ COLUMN : ORDERS.O_ORDERKEY, ORDERS.O_ORDERSTATUS, ORDERS.O_TOTALPRICE,
ORDERS.O_ORDERDATE, ORDERS.O_COMMENT
    PHYSICAL FILTER : ORDERS.O_ORDERSTATUS = 'F' AND ORDERS.O_ORDERDATE >=
DATE'1996-01-01' AND ORDERS.O_ORDERDATE < DATE'1996-02-01'
    LOGICAL FILTER : ORDERS.O_COMMENT LIKE '%Customer%Complaints%'
4 - COLUMN : LINEITEM.L_ORDERKEY AS L_ORDERKEY
5 - TARGET : LINEITEM.L_ORDERKEY
6 - GROUP KEY : LINEITEM.L_ORDERKEY
    RECORD COLUMN : SUM( LINEITEM.L_QUANTITY )
    LOGICAL FILTER : SUM( LINEITEM.L_QUANTITY ) > 300

```

```

7 - READ INDEX COLUMN : LINEITEM.L_ORDERKEY
   READ TABLE COLUMN : LINEITEM.L_QUANTITY, LINEITEM.L_SHIPDATE,
LINEITEM.L_COMMITDATE, LINEITEM.L_RECEIPTDATE
   MIN RANGE : LINEITEM.L_ORDERKEY = {ORDERS.O_ORDERKEY}
   MAX RANGE : LINEITEM.L_ORDERKEY = {ORDERS.O_ORDERKEY}
   PHYSICAL TABLE FILTER : LINEITEM.L_SHIPDATE >= DATE'1996-01-01' AND
LINEITEM.L_SHIPDATE < DATE'1996-02-01' AND LINEITEM.L_RECEIPTDATE > LINEITEM.L_COMMITDATE
<<< end print plan

```

The hint is ignored so it is unnested by anti-semi join method, then performed in nested loop join method.

### HASH\_ISJ

If HASH\_ISJ hint is specified, an optimizer unnests the subquery in inverted semi join form, and performs the join in hash join method.

It is operated in the same way as that of UNNEST\_HASH\_OUT hint. However, UNNEST\_HASH\_OUT hint is applied to both semi join and anti-semi join, on the other hand, HASH\_ISJ hint is applied only to semi join. Therefore, if the hint above is specified on a subquery which is unnested with anti-semi join, then an optimizer ignores it.

The following is an example of using HASH\_ISJ hint.

```

\EXPLAIN PLAN
SELECT
    o_orderdate,
    o_totalprice
FROM orders
WHERE o_orderkey IN (
    SELECT /*+ HASH_ISJ */
        l_orderkey
    FROM lineitem
    GROUP BY l_orderkey
    HAVING sum(l_quantity) > 300
)
;
>>> start print plan
< Execution Plan >
=====
|  IDX  |  NODE DESCRIPTION  |
-----
|    0  |  SELECT STATEMENT  |

```

```

| 1 | QUERY BLOCK ("QB_IDX_2") |
| 2 | HASH JOIN (INNER JOIN) |
| 3 | INLINE_VIEW ("V4") |
| 4 | QUERY BLOCK ("QB_IDX_6") |
| 5 | GROUP HASH INSTANT |
| 6 | TABLE ACCESS ("LINEITEM") |
| 7 | HASH JOIN INSTANT |
| 8 | TABLE ACCESS ("ORDERS") |
=====
1 - TARGET : ORDERS.O_ORDERDATE, ORDERS.O_TOTALPRICE
2 - JOINED COLUMN : ORDERS.O_ORDERDATE, ORDERS.O_TOTALPRICE
3 - COLUMN : LINEITEM.L_ORDERKEY AS L_ORDERKEY
4 - TARGET : LINEITEM.L_ORDERKEY
5 - GROUP KEY : LINEITEM.L_ORDERKEY
   RECORD COLUMN : SUM( LINEITEM.L_QUANTITY )
   READ KEY COLUMN : LINEITEM.L_ORDERKEY
   READ RECORD COLUMN : SUM( LINEITEM.L_QUANTITY )
   PHYSICAL FILTER : SUM( LINEITEM.L_QUANTITY ) > 300
6 - READ COLUMN : LINEITEM.L_ORDERKEY, LINEITEM.L_QUANTITY
7 - HASH KEY : ORDERS.O_ORDERKEY
   RECORD COLUMN : ORDERS.O_ORDERDATE, ORDERS.O_TOTALPRICE
   READ KEY COLUMN : ORDERS.O_ORDERKEY, ORDERS.O_ORDERDATE, ORDERS.O_TOTALPRICE
   HASH FILTER : ORDERS.O_ORDERKEY = V4.L_ORDERKEY
   FETCH ONE ROW
8 - READ COLUMN : ORDERS.O_ORDERKEY, ORDERS.O_TOTALPRICE, ORDERS.O_ORDERDATE
<<< end print plan

```

In the example above, HASH\_ISJ hint is applied so a subquery is unnested with inverted semi join and hash join is performed. Also, the semi join is converted into an inner join because both o\_orderkey and l\_orderkey are primary keys.

The following is an example of using HASH\_ISJ hint in a subquery which can be unnested only in anti-semi join form.

```

\EXPLAIN PLAN
SELECT
    o_orderdate,
    o_totalprice
FROM orders
WHERE o_orderkey NOT IN (
    SELECT /*+ HASH_ISJ */
        l_orderkey

```



```

        FROM lineitem
        WHERE l_shipdate >= date '1996-01-01'
              AND l_shipdate < date '1996-02-01'
              AND l_commitdate < l_receiptdate
        GROUP BY l_orderkey
        HAVING sum(l_quantity) > 300
    )
AND o_orderdate >= date '1996-01-01'
AND o_orderdate < date '1996-02-01'
AND o_comment like '%Customer%Complaints%'
AND o_orderstatus = 'F'
;
>>> start print plan
< Execution Plan >
=====
|  IDX  |  NODE DESCRIPTION                                |
-----|-----|
|  0  |  SELECT STATEMENT                                |
|  1  |  QUERY BLOCK ("SQB_IDX_2")                       |
|  2  |  NESTED JOIN (ANTI SEMI)                         |
|  3  |  TABLE ACCESS ("ORDERS")                        |
|  4  |  INLINE_VIEW ("V5")                              |
|  5  |  QUERY BLOCK ("SQB_IDX_6")                       |
|  6  |  GROUP                                            |
|  7  |  INDEX ACCESS ("LINEITEM", "LINEITEM_PK_INDEX") |
=====
1 - TARGET : ORDERS.O_ORDERDATE, ORDERS.O_TOTALPRICE
2 - JOINED COLUMN : ORDERS.O_ORDERDATE, ORDERS.O_TOTALPRICE
3 - READ COLUMN : ORDERS.O_ORDERKEY, ORDERS.O_ORDERSTATUS, ORDERS.O_TOTALPRICE,
ORDERS.O_ORDERDATE, ORDERS.O_COMMENT
    PHYSICAL FILTER : ORDERS.O_ORDERSTATUS = 'F' AND ORDERS.O_ORDERDATE >=
DATE'1996-01-01' AND ORDERS.O_ORDERDATE < DATE'1996-02-01'
    LOGICAL FILTER : ORDERS.O_COMMENT LIKE '%Customer%Complaints%'
4 - COLUMN : LINEITEM.L_ORDERKEY AS L_ORDERKEY
5 - TARGET : LINEITEM.L_ORDERKEY
6 - GROUP KEY : LINEITEM.L_ORDERKEY
    RECORD COLUMN : SUM( LINEITEM.L_QUANTITY )
    LOGICAL FILTER : SUM( LINEITEM.L_QUANTITY ) > 300
7 - READ INDEX COLUMN : LINEITEM.L_ORDERKEY
    READ TABLE COLUMN : LINEITEM.L_QUANTITY, LINEITEM.L_SHIPDATE,
LINEITEM.L_COMMITDATE, LINEITEM.L_RECEIPTDATE

```

```

MIN RANGE : LINEITEM.L_ORDERKEY = {ORDERS.O_ORDERKEY}
MAX RANGE : LINEITEM.L_ORDERKEY = {ORDERS.O_ORDERKEY}
PHYSICAL TABLE FILTER : LINEITEM.L_SHIPDATE >= DATE'1996-01-01' AND
LINEITEM.L_SHIPDATE < DATE'1996-02-01' AND LINEITEM.L_RECEIPTDATE > LINEITEM.L_COMMITDATE
<<< end print plan

```

The hint is ignored so it is unnested by anti-semi join method, then performed in nested loop join method.

## NL\_AJ

If NL\_AJ hint is specified, an optimizer unnests the subquery in anti-semi join form, and performs the join in nested loop method.

It is operated in the same way as that of UNNEST\_NL hint. However, UNNEST\_NL hint is applied to both semi join and anti-semi join, on the other hand, NL\_AJ hint is applied only to anti-semi join. Therefore, if the hint above is specified on a subquery which is unnested with semi join, then an optimizer ignores it.

The following is an example of using NL\_AJ hint.

```

\EXPLAIN PLAN
SELECT
    o_orderdate,
    o_totalprice
FROM orders
WHERE o_orderkey NOT IN (
    SELECT /*+ NL_AJ */
        l_orderkey
    FROM lineitem
    GROUP BY l_orderkey
    HAVING sum(l_quantity) > 300
)
;
>>> start print plan
< Execution Plan >
=====
|  IDX  |  NODE DESCRIPTION  |
-----|-----|
|   0   |  SELECT STATEMENT  |
|   1   |  QUERY BLOCK ("QB_IDX_2") |
|   2   |    NESTED JOIN (ANTI SEMI) |
|   3   |      TABLE ACCESS ("ORDERS") |
|   4   |      INLINE_VIEW ("V5") |

```

```

| 5 |          QUERY BLOCK ("SQB_IDX_6")          |
| 6 |          GROUP                               |
| 7 |          INDEX ACCESS ("LINEITEM", "LINEITEM_PK_INDEX") |
=====
1 - TARGET : ORDERS.O_ORDERDATE, ORDERS.O_TOTALPRICE
2 - JOINED COLUMN : ORDERS.O_ORDERDATE, ORDERS.O_TOTALPRICE
3 - READ COLUMN : ORDERS.O_ORDERKEY, ORDERS.O_TOTALPRICE, ORDERS.O_ORDERDATE
4 - COLUMN : LINEITEM.L_ORDERKEY AS L_ORDERKEY
5 - TARGET : LINEITEM.L_ORDERKEY
6 - GROUP KEY : LINEITEM.L_ORDERKEY
   RECORD COLUMN : SUM( LINEITEM.L_QUANTITY )
   LOGICAL FILTER : SUM( LINEITEM.L_QUANTITY ) > 300
7 - READ INDEX COLUMN : LINEITEM.L_ORDERKEY
   READ TABLE COLUMN : LINEITEM.L_QUANTITY
   MIN RANGE : LINEITEM.L_ORDERKEY = {ORDERS.O_ORDERKEY}
   MAX RANGE : LINEITEM.L_ORDERKEY = {ORDERS.O_ORDERKEY}
<<< end print plan

```

The following is an example of using NL\_AJ hint in a subquery which can be unnested only in semi join form.

```

\EXPLAIN PLAN
SELECT
    o_orderdate,
    o_totalprice
FROM orders
WHERE o_comment IN (
    SELECT /*+ NL_AJ */
        l_comment
    FROM lineitem
    WHERE l_shipdate >= date '1996-01-01'
    AND   l_shipdate < date '1996-02-01'
)
;
>>> start print plan
< Execution Plan >
=====
|  IDX  |  NODE DESCRIPTION          |
-----|-----|
|  0  |  SELECT STATEMENT          |
|  1  |  QUERY BLOCK ("SQB_IDX_2") |

```

```

| 2 |      HASH JOIN (SEMI) |
| 3 |      TABLE ACCESS ("ORDERS") |
| 4 |      HASH JOIN INSTANT (UNIQUE) |
| 5 |      TABLE ACCESS ("LINEITEM") |
=====
1 - TARGET : ORDERS.O_ORDERDATE, ORDERS.O_TOTALPRICE
2 - JOINED COLUMN : ORDERS.O_ORDERDATE, ORDERS.O_TOTALPRICE
3 - READ COLUMN : ORDERS.O_TOTALPRICE, ORDERS.O_ORDERDATE, ORDERS.O_COMMENT
4 - HASH KEY : LINEITEM.L_COMMENT
   READ KEY COLUMN : LINEITEM.L_COMMENT
   HASH FILTER : LINEITEM.L_COMMENT = ORDERS.O_COMMENT
   FETCH ONE ROW
5 - READ COLUMN : LINEITEM.L_SHIPDATE, LINEITEM.L_COMMENT
   PHYSICAL FILTER : LINEITEM.L_SHIPDATE >= DATE'1996-01-01' AND LINEITEM.L_SHIPDATE
< DATE'1996-02-01'
<<< end print plan

```

The hint is ignored so it is unnested by semi join method, then performed in hash join method. Also, the semi join is converted into an inner join because both o\_orderkey and l\_orderkey are primary keys.

### INL\_AJ

If INL\_AJ hint is specified, an optimizer unnests the subquery in anti-semi join form, and performs the join in instant nested loop join method.

It is operated in the same way as that of UNNEST\_INL hint. However, UNNEST\_INL hint is applied to both semi join and anti-semi join, on the other hand, INL\_AJ hint is applied only to anti-semi join. Therefore, if the hint above is specified on a subquery which is unnested with semi join, then an optimizer ignores it.

The following is an example of using INL\_AJ hint.

```

\EXPLAIN PLAN
SELECT
    o_orderdate,
    o_totalprice
FROM orders
WHERE o_orderkey NOT IN (
    SELECT /*+ INL_AJ */
        l_orderkey
    FROM lineitem
    GROUP BY l_orderkey
    HAVING sum(l_quantity) > 300
)

```

```

;
>>> start print plan
< Execution Plan >
=====
|  IDX  |  NODE DESCRIPTION  |
-----|-----|
|   0   |  SELECT STATEMENT  |
|   1   |    QUERY BLOCK ("QB_IDX_2")  |
|   2   |      NESTED JOIN (ANTI SEMI)  |
|   3   |        TABLE ACCESS ("ORDERS")  |
|   4   |        SORT JOIN INSTANT  |
|   5   |          INLINE_VIEW ("V6")  |
|   6   |            QUERY BLOCK ("QB_IDX_6")  |
|   7   |              GROUP HASH INSTANT  |
|   8   |                TABLE ACCESS ("LINEITEM")  |
=====
1 - TARGET : ORDERS.O_ORDERDATE, ORDERS.O_TOTALPRICE
2 - JOINED COLUMN : ORDERS.O_ORDERDATE, ORDERS.O_TOTALPRICE
3 - READ COLUMN : ORDERS.O_ORDERKEY, ORDERS.O_TOTALPRICE, ORDERS.O_ORDERDATE
4 - SORT KEY : "$V6.L_ORDERKEY ASC NULLS LAST"
   READ KEY COLUMN : $V6.L_ORDERKEY
   MIN RANGE : $V6.L_ORDERKEY = {ORDERS.O_ORDERKEY}
   MAX RANGE : $V6.L_ORDERKEY = {ORDERS.O_ORDERKEY}
5 - COLUMN : LINEITEM.L_ORDERKEY AS L_ORDERKEY
6 - TARGET : LINEITEM.L_ORDERKEY
7 - GROUP KEY : LINEITEM.L_ORDERKEY
   RECORD COLUMN : SUM( LINEITEM.L_QUANTITY )
   READ KEY COLUMN : LINEITEM.L_ORDERKEY
   READ RECORD COLUMN : SUM( LINEITEM.L_QUANTITY )
   PHYSICAL FILTER : SUM( LINEITEM.L_QUANTITY ) > 300
8 - READ COLUMN : LINEITEM.L_ORDERKEY, LINEITEM.L_QUANTITY
<<< end print plan

```

The following is an example of using INL\_AJ hint in a subquery which can be unnested only in semi join form.

```

\EXPLAIN PLAN
SELECT
    o_orderdate,
    o_totalprice
FROM orders

```

```

WHERE o_orderkey IN (
                SELECT /*+ INL_AJ */
                   l_orderkey
                FROM   lineitem
                GROUP BY l_orderkey
                HAVING  sum(l_quantity) > 300
            )
;
>>> start print plan
< Execution Plan >
=====
|  IDX  |  NODE DESCRIPTION  |
=====
|   0   |  SELECT STATEMENT  |
|   1   |    QUERY BLOCK ("SQB_IDX_2")  |
|   2   |      NESTED JOIN (INNER JOIN)  |
|   3   |        INLINE_VIEW ("S4")  |
|   4   |          QUERY BLOCK ("SQB_IDX_6")  |
|   5   |            GROUP HASH INSTANT  |
|   6   |              TABLE ACCESS ("LINEITEM")  |
|   7   |                INDEX ACCESS ("ORDERS", "ORDERS_PK_INDEX")  |
=====
1 - TARGET : ORDERS.O_ORDERDATE, ORDERS.O_TOTALPRICE
2 - JOINED COLUMN : ORDERS.O_ORDERDATE, ORDERS.O_TOTALPRICE
3 - COLUMN : LINEITEM.L_ORDERKEY AS L_ORDERKEY
4 - TARGET : LINEITEM.L_ORDERKEY
5 - GROUP KEY : LINEITEM.L_ORDERKEY
   RECORD COLUMN : SUM( LINEITEM.L_QUANTITY )
   READ KEY COLUMN : LINEITEM.L_ORDERKEY
   READ RECORD COLUMN : SUM( LINEITEM.L_QUANTITY )
   PHYSICAL FILTER : SUM( LINEITEM.L_QUANTITY ) > 300
6 - READ COLUMN : LINEITEM.L_ORDERKEY, LINEITEM.L_QUANTITY
7 - READ INDEX COLUMN : ORDERS.O_ORDERKEY
   READ TABLE COLUMN : ORDERS.O_TOTALPRICE, ORDERS.O_ORDERDATE
   MIN RANGE : ORDERS.O_ORDERKEY = {S4.L_ORDERKEY}
   MAX RANGE : ORDERS.O_ORDERKEY = {S4.L_ORDERKEY}
   FETCH ONE ROW
<<< end print plan

```

The hint is ignored so it is unnested by semi join method, then performed in nested loop join method. Also, the semi join is converted into an inner join because both o\_orderkey and l\_orderkey are primary keys.

## MERGE\_AJ

If MERGE\_AJ hint is specified, an optimizer unnests the subquery in anti-semi join form, and performs the join in merge join method.

It is operated in the same way as that of UNNEST\_MERGE hint. However, UNNEST\_MERGE hint is applied to both semi join and anti-semi join, on the other hand, MERGE\_AJ hint is applied only to anti-semi join. Therefore, if the hint above is specified on a subquery which is unnested with semi join, then an optimizer ignores it.

The following is an example of using MERGE\_AJ hint.

```
\EXPLAIN PLAN
SELECT
    o_orderdate,
    o_totalprice
FROM orders
WHERE o_orderkey NOT IN (
    SELECT /*+ MERGE_AJ */
        l_orderkey
    FROM lineitem
    GROUP BY l_orderkey
    HAVING sum(l_quantity) > 300
)
;
>>> start print plan
< Execution Plan >
=====
|  IDX  |  NODE DESCRIPTION  |
-----|-----|
|   0   |  SELECT STATEMENT  |
|   1   |  QUERY BLOCK ("QB_IDX_2")  |
|   2   |  MERGE JOIN (ANTI SEMI)  |
|   3   |  INDEX ACCESS ("ORDERS", "ORDERS_PK_INDEX")  |
|   4   |  SORT JOIN INSTANT (UNIQUE)  |
|   5   |  INLINE_VIEW ("V6")  |
|   6   |  QUERY BLOCK ("QB_IDX_6")  |
|   7   |  GROUP HASH INSTANT  |
|   8   |  TABLE ACCESS ("LINEITEM")  |
=====
1 - TARGET : ORDERS.O_ORDERDATE, ORDERS.O_TOTALPRICE
2 - JOINED COLUMN : ORDERS.O_ORDERDATE, ORDERS.O_TOTALPRICE
```

```

        ON FILTER (Equi) : ORDERS.O_ORDERKEY = $V6.L_ORDERKEY
3 - READ INDEX COLUMN : ORDERS.O_ORDERKEY
    READ TABLE COLUMN : ORDERS.O_TOTALPRICE, ORDERS.O_ORDERDATE
4 - SORT KEY : "$V6.L_ORDERKEY ASC NULLS LAST"
    READ KEY COLUMN : $V6.L_ORDERKEY
    MIN RANGE : $V6.L_ORDERKEY >= {ORDERS.O_ORDERKEY}
    MAX RANGE : $V6.L_ORDERKEY IS NOT NULL
5 - COLUMN : LINEITEM.L_ORDERKEY AS L_ORDERKEY
6 - TARGET : LINEITEM.L_ORDERKEY
7 - GROUP KEY : LINEITEM.L_ORDERKEY
    RECORD COLUMN : SUM( LINEITEM.L_QUANTITY )
    READ KEY COLUMN : LINEITEM.L_ORDERKEY
    READ RECORD COLUMN : SUM( LINEITEM.L_QUANTITY )
    PHYSICAL FILTER : SUM( LINEITEM.L_QUANTITY ) > 300
8 - READ COLUMN : LINEITEM.L_ORDERKEY, LINEITEM.L_QUANTITY
<<< end print plan

```

The following is an example of using MERGE\_AJ hint in a subquery which can be unnested only in semi join form.

```

\EXPLAIN PLAN
SELECT
    o_orderdate,
    o_totalprice
FROM orders
WHERE o_orderkey IN (
    SELECT /*+ MERGE_AJ */
        l_orderkey
    FROM lineitem
    GROUP BY l_orderkey
    HAVING sum(l_quantity) > 300
)
;
>>> start print plan
< Execution Plan >
=====
|  IDX  |  NODE DESCRIPTION  |
=====
|   0   |  SELECT STATEMENT  |
|   1   |  QUERY BLOCK ("SQB_IDX_2")  |
|   2   |  NESTED JOIN (INNER JOIN)  |
=====

```



```

| 3 |      INLINE_VIEW ("V4")      |
| 4 |      QUERY_BLOCK ("QB_IDX_6") |
| 5 |      GROUP_HASH_INSTANT      |
| 6 |      TABLE_ACCESS ("LINEITEM") |
| 7 |      INDEX_ACCESS ("ORDERS", "ORDERS_PK_INDEX") |
=====
1 - TARGET : ORDERS.O_ORDERDATE, ORDERS.O_TOTALPRICE
2 - JOINED COLUMN : ORDERS.O_ORDERDATE, ORDERS.O_TOTALPRICE
3 - COLUMN : LINEITEM.L_ORDERKEY AS L_ORDERKEY
4 - TARGET : LINEITEM.L_ORDERKEY
5 - GROUP KEY : LINEITEM.L_ORDERKEY
   RECORD COLUMN : SUM( LINEITEM.L_QUANTITY )
   READ KEY COLUMN : LINEITEM.L_ORDERKEY
   READ RECORD COLUMN : SUM( LINEITEM.L_QUANTITY )
   PHYSICAL FILTER : SUM( LINEITEM.L_QUANTITY ) > 300
6 - READ COLUMN : LINEITEM.L_ORDERKEY, LINEITEM.L_QUANTITY
7 - READ INDEX COLUMN : ORDERS.O_ORDERKEY
   READ TABLE COLUMN : ORDERS.O_TOTALPRICE, ORDERS.O_ORDERDATE
   MIN RANGE : ORDERS.O_ORDERKEY = {V4.L_ORDERKEY}
   MAX RANGE : ORDERS.O_ORDERKEY = {V4.L_ORDERKEY}
   FETCH ONE ROW
<<< end print plan

```

The hint is ignored so it is unnested by semi join method, then performed in nested loop join method. Also, the semi join is converted into an inner join because both o\_orderkey and l\_orderkey are primary keys.

## HASH\_AJ

If HASH\_AJ hint is specified, an optimizer unnests the subquery in anti-semi join form, and performs the join in hash join method.

It is operated in the same way as that of UNNEST\_HASH hint. However, UNNEST\_HASH hint is applied to both semi join and anti-semi join, on the other hand, HASH\_AJ hint is applied only to anti-semi join. Therefore, if the hint above is specified on a subquery which is unnested with semi join, then an optimizer ignores it.

The following is an example of using HASH\_AJ hint.

```

\EXPLAIN PLAN
SELECT
    o_orderdate,
    o_totalprice
FROM orders

```

```

WHERE o_orderkey NOT IN (
                SELECT /*+ HASH_AJ */
                   l_orderkey
                FROM   lineitem
                GROUP BY l_orderkey
                HAVING  sum(l_quantity) > 300
            )
;
>>> start print plan
< Execution Plan >
=====
|  IDX  |  NODE DESCRIPTION  |
=====
|   0   |  SELECT STATEMENT  |
|   1   |    QUERY BLOCK ("QB_IDX_2")  |
|   2   |      HASH JOIN (ANTI SEMI)  |
|   3   |        TABLE ACCESS ("ORDERS")  |
|   4   |      HASH JOIN INSTANT (UNIQUE)  |
|   5   |        INLINE_VIEW ("V6")  |
|   6   |          QUERY BLOCK ("QB_IDX_6")  |
|   7   |            GROUP HASH INSTANT  |
|   8   |              TABLE ACCESS ("LINEITEM")  |
=====
1 - TARGET : ORDERS.O_ORDERDATE, ORDERS.O_TOTALPRICE
2 - JOINED COLUMN : ORDERS.O_ORDERDATE, ORDERS.O_TOTALPRICE
3 - READ COLUMN : ORDERS.O_ORDERKEY, ORDERS.O_TOTALPRICE, ORDERS.O_ORDERDATE
4 - HASH KEY : V6.L_ORDERKEY
  READ KEY COLUMN : V6.L_ORDERKEY
  HASH FILTER : V6.L_ORDERKEY = ORDERS.O_ORDERKEY
  FETCH ONE ROW
5 - COLUMN : LINEITEM.L_ORDERKEY AS L_ORDERKEY
6 - TARGET : LINEITEM.L_ORDERKEY
7 - GROUP KEY : LINEITEM.L_ORDERKEY
  RECORD COLUMN : SUM( LINEITEM.L_QUANTITY )
  READ KEY COLUMN : LINEITEM.L_ORDERKEY
  READ RECORD COLUMN : SUM( LINEITEM.L_QUANTITY )
  PHYSICAL FILTER : SUM( LINEITEM.L_QUANTITY ) > 300
8 - READ COLUMN : LINEITEM.L_ORDERKEY, LINEITEM.L_QUANTITY
<<< end print plan

```

The following is an example of using HASH\_AJ hint in a subquery which can be unnested only in semi joi

n form.

```

\EXPLAIN PLAN
SELECT
    o_orderdate,
    o_totalprice
FROM orders
WHERE o_orderkey IN (
    SELECT /*+ HASH_AJ */
        l_orderkey
    FROM lineitem
    GROUP BY l_orderkey
    HAVING sum(l_quantity) > 300
)
;
>>> start print plan
< Execution Plan >
=====
|  IDX  |  NODE DESCRIPTION  |
-----|-----|
|  0  |  SELECT STATEMENT  |
|  1  |  QUERY BLOCK ("QB_IDX_2")  |
|  2  |  NESTED JOIN (INNER JOIN)  |
|  3  |  INLINE_VIEW ("V4")  |
|  4  |  QUERY BLOCK ("QB_IDX_6")  |
|  5  |  GROUP HASH INSTANT  |
|  6  |  TABLE ACCESS ("LINEITEM")  |
|  7  |  INDEX ACCESS ("ORDERS", "ORDERS_PK_INDEX")  |
=====
1 - TARGET : ORDERS.O_ORDERDATE, ORDERS.O_TOTALPRICE
2 - JOINED COLUMN : ORDERS.O_ORDERDATE, ORDERS.O_TOTALPRICE
3 - COLUMN : LINEITEM.L_ORDERKEY AS L_ORDERKEY
4 - TARGET : LINEITEM.L_ORDERKEY
5 - GROUP KEY : LINEITEM.L_ORDERKEY
   RECORD COLUMN : SUM( LINEITEM.L_QUANTITY )
   READ KEY COLUMN : LINEITEM.L_ORDERKEY
   READ RECORD COLUMN : SUM( LINEITEM.L_QUANTITY )
   PHYSICAL FILTER : SUM( LINEITEM.L_QUANTITY ) > 300
6 - READ COLUMN : LINEITEM.L_ORDERKEY, LINEITEM.L_QUANTITY
7 - READ INDEX COLUMN : ORDERS.O_ORDERKEY
   READ TABLE COLUMN : ORDERS.O_TOTALPRICE, ORDERS.O_ORDERDATE

```

```

          MIN RANGE : ORDERS.O_ORDERKEY = {$V4.L_ORDERKEY}
          MAX RANGE : ORDERS.O_ORDERKEY = {$V4.L_ORDERKEY}
          FETCH ONE ROW
<<< end print plan

```

The hint is ignored so it is unnested by semi join method, then performed in nested loop join method. Also, the semi join is converted into an inner join because both o\_orderkey and l\_orderkey are primary keys.

## <unnest join driver hints>

Those hints are available when performing subquery unnesting in the cluster system. They are ignored in the standalone system.

### LOCAL\_UNNEST

If LOCAL\_UNNEST hint is specified, an optimizer transforms the subquery into the join statement which guarantees the same result, then performs the join in a local. In other words, it performs the join by bringing results of both a left child and a right child to the local.

The following is an example of using LOCAL\_UNNEST hint.

```

\EXPLAIN PLAN
SELECT
    o_orderdate,
    o_totalprice
FROM orders
WHERE o_orderkey IN (
    SELECT /*+ LOCAL_UNNEST */
        l_orderkey
    FROM lineitem
    GROUP BY l_orderkey
    HAVING sum(l_quantity) > 300
)
;
>>> start print plan
< Execution Plan >
=====
|  IDX  |  NODE DESCRIPTION  |
-----|-----|
|    0  |  SELECT STATEMENT  |
|    1  |  QUERY BLOCK ("QB_IDX_2")  |
|    2  |  HASH JOIN (INNER JOIN)  |
|    3  |  PLAN BASED CLUSTER  |
|    4  |  TABLE ACCESS ("ORDERS")  |

```

```

| 5 |          HASH JOIN INSTANT          |
| 6 |          PLAN BASED CLUSTER          |
| 7 |          INLINE_VIEW ("V8")         |
| 8 |          QUERY BLOCK ("QB_IDX_6")   |
| 9 |          GROUP HASH INSTANT         |
|10 |          TABLE ACCESS ("LINEITEM") |
=====
1 - TARGET : ORDERS.O_ORDERDATE, ORDERS.O_TOTALPRICE
2 - JOINED COLUMN : ORDERS.O_ORDERDATE, ORDERS.O_TOTALPRICE
3 - SQL : SELECT /*+ FULL( _A1 ) */ "_A1"."O_ORDERKEY", "_A1"."O_TOTALPRICE",
"_A1"."O_ORDERDATE" FROM "PUBLIC"."ORDERS"@LOCAL AS "_A1"
      TARGET DOMAIN : G1(G1N1,G1N2) 0 rows, G2(G2N1,G2N2) 0 rows, G3(G3N1,G3N2) 0 rows
4 - HASH SHARD ( # 3 )
      READ COLUMN : ORDERS.O_ORDERKEY, ORDERS.O_TOTALPRICE, ORDERS.O_ORDERDATE
5 - HASH KEY : V8.L_ORDERKEY
      READ KEY COLUMN : V8.L_ORDERKEY
      HASH FILTER : V8.L_ORDERKEY = ORDERS.O_ORDERKEY
6 - SQL : SELECT /*+ NO_MERGE( _A1 ) */ * FROM ( SELECT /*+ USE_GROUP_HASH(10) FULL(
_A2 ) */ "_A2"."L_ORDERKEY" FROM "PUBLIC"."LINEITEM"@LOCAL AS "_A2" GROUP BY
"_A2"."L_ORDERKEY" HAVING SUM( "_A2"."L_QUANTITY" ) > :_V0 ) AS "_A1"("L_ORDERKEY")
      TARGET DOMAIN : G1(G1N1,G1N2) 0 rows, G2(G2N1,G2N2) 0 rows, G3(G3N1,G3N2) 0 rows
7 - COLUMN : LINEITEM.L_ORDERKEY AS L_ORDERKEY
8 - TARGET : LINEITEM.L_ORDERKEY
9 - GROUP KEY : LINEITEM.L_ORDERKEY
      RECORD COLUMN : SUM( LINEITEM.L_QUANTITY )
      READ KEY COLUMN : LINEITEM.L_ORDERKEY
      READ RECORD COLUMN : SUM( LINEITEM.L_QUANTITY )
      PHYSICAL FILTER : SUM( LINEITEM.L_QUANTITY ) > 300
10 - HASH SHARD ( # 3 )
      READ COLUMN : LINEITEM.L_ORDERKEY, LINEITEM.L_QUANTITY
<<< end print plan

```

In the execution plan above, HASH JOIN (INNER JOIN) is performed in local by bringing TABLE ACCESS ("ORDERS") result from PLAN BASED CLUSTER of IDX 3 and bringing INLINE\_VIEW ("V8") result from PLAN BASED CLUSTER of IDX 6.

## REMOTE\_UNNEST

If REMOTE\_UNNEST hint is specified, an optimizer transforms the subquery into the join statement which guarantees the same result. Then it performs the join in remote. In other words, it performs the join in each group.

The following is an example of using REMOTE\_UNNEST hint.

```

\EXPLAIN PLAN
SELECT
    o_orderdate,
    o_totalprice
FROM orders
WHERE o_orderkey IN (
    SELECT /*+ REMOTE_UNNEST */
        l_orderkey
    FROM lineitem
    GROUP BY l_orderkey
    HAVING sum(l_quantity) > 300
)

```

```
;
```

```
>>> start print plan
```

```
< Execution Plan >
```

```

=====
|  IDX  |  NODE DESCRIPTION  |
-----
|   0   |  SELECT STATEMENT  |
|   1   |    QUERY BLOCK ("QB_IDX_2")  |
|   2   |      PLAN BASED CLUSTER  |
|   3   |        NESTED JOIN (INNER JOIN)  |
|   4   |          INLINE_VIEW ("V5")  |
|   5   |            QUERY BLOCK ("QB_IDX_6")  |
|   6   |              GROUP HASH INSTANT  |
|   7   |                TABLE ACCESS ("LINEITEM")  |
|   8   |                  INDEX ACCESS ("ORDERS", "ORDERS_PK_INDEX")  |
=====

```

```

1 - TARGET : ORDERS.O_ORDERDATE, ORDERS.O_TOTALPRICE
2 - SQL : SELECT /*+ KEEP_JOINED_TABLE USE_NL_IN( _A1 ) NO_MERGE( _A2 ) INDEX( _A1,
"PUBLIC"."ORDERS_PK_INDEX" ) */ "_A1"."O_ORDERDATE", "_A1"."O_TOTALPRICE" FROM ( ( SELECT /*+
USE_GROUP_HASH(10) FULL( _A3 ) */ "_A3"."L_ORDERKEY" FROM "PUBLIC"."LINEITEM"@LOCAL AS "_A3"
GROUP BY "_A3"."L_ORDERKEY" HAVING SUM( "_A3"."L_QUANTITY" ) > :_V0 ) AS "_A2"("L_ORDERKEY")
INNER JOIN "PUBLIC"."ORDERS"@LOCAL AS "_A1" ON true ) ALIAS "_A4" WHERE "_A1"."O_ORDERKEY" =
"_A2"."L_ORDERKEY"

```

```
TARGET DOMAIN : G1(G1N1,G1N2) 0 rows, G2(G2N1,G2N2) 0 rows, G3(G3N1,G3N2) 0 rows
```

```
3 - JOINED COLUMN : ORDERS.O_ORDERDATE, ORDERS.O_TOTALPRICE
```

```
4 - COLUMN : LINEITEM.L_ORDERKEY AS L_ORDERKEY
```

```
5 - TARGET : LINEITEM.L_ORDERKEY
```

```
6 - GROUP KEY : LINEITEM.L_ORDERKEY
```

```
RECORD COLUMN : SUM( LINEITEM.L_QUANTITY )
```

```

      READ KEY COLUMN : LINEITEM.L_ORDERKEY
      READ RECORD COLUMN : SUM( LINEITEM.L_QUANTITY )
        PHYSICAL FILTER : SUM( LINEITEM.L_QUANTITY ) > 300
7 - HASH SHARD ( # 3 )
      READ COLUMN : LINEITEM.L_ORDERKEY, LINEITEM.L_QUANTITY
8 - HASH SHARD ( # 3 )
      READ INDEX COLUMN : ORDERS.O_ORDERKEY
      READ TABLE COLUMN : ORDERS.O_TOTALPRICE, ORDERS.O_ORDERDATE
        MIN RANGE : ORDERS.O_ORDERKEY = {$V5.L_ORDERKEY}
        MAX RANGE : ORDERS.O_ORDERKEY = {$V5.L_ORDERKEY}
      FETCH ONE ROW
<<< end print plan

```

In the execution plan above, the join is performed in each group and join results are collected from PLAN BASED CLUSTER of IDX 2, then returned.

## <unnest join pusher hints>

Those hints are available when performing subquery unnesting in the cluster system. They are ignored in the standalone system.

### PUSHER\_SUBQ

If PUSHER\_SUBQ hint is specified, an optimizer transforms the subquery into the join statement which guarantees the same result. Then, it builds the view or the table which was created by unnesting the subquery as a pusher table when performing the join in a remote.

The following is an example of using PUSHER\_SUBQ hint.

```

\EXPLAIN PLAN
SELECT p_name
  FROM part
 WHERE p_partkey IN ( SELECT /*+ PUSHER_SUBQ */
                      l_partkey
                      FROM lineitem
                      WHERE l_shipdate = date'1998-12-01'
                    );

```

< Execution Plan >

```

=====
|IDX |  NODE DESCRIPTION                                | ROWS |
-----|-----|-----|
|  0 |  SELECT STATEMENT                                |    18 |
|  1 |    QUERY BLOCK ("SQB_IDX_2")                    |    18 |
|  2 |      SINGLE CLUSTER                              | LOCAL/REMOTE 18 |

```

```

| 3 |          CLUSTER PUSHER ("$_NI_6")                | 18 |
| 4 |          PLAN BASED CLUSTER                        | LOCAL/REMOTE 18 |
| 5 |          TABLE ACCESS ("LINEITEM")                | 7 |
| 6 |          SELECT STATEMENT                          | 5 |
| 7 |          QUERY BLOCK ("$_QB_IDX_2")                | 5 |
| 8 |          NESTED JOIN (INVERTED SEMI)                | 5 |
| 9 |          SORT JOIN INSTANT (UNIQUE)                | 5 |
|10 |          PUSHER TABLE ACCESS ("$_NI_6" AS _A2)    | 5 |
|11 |          INDEX ACCESS ("PART" AS _A1, "PART_PK_INDEX") | 5 |

```

```

=====
1 - TARGET : PART.P_NAME
2 - SQL :
  SELECT /*+ KEEP_JOINED_TABLE USE_NL_IN( _A1 )
          FULL( _A2 )
          INDEX( _A1, "PUBLIC"."PART_PK_INDEX" )
  */
  "_A1". "P_NAME"
FROM ( "PUBLIC"."PART"@G1N1"|G1N2"|G2N1"|G2N2"|G3N1"|G3N2"
      AS "_A1"
      SEMI JOIN
      "SESSION_SCHEMA"."$_NI_6"@LOCAL AS "_A2"
      ON "_A1"."P_PARTKEY" = "_A2"."L_PARTKEY"
      ) ALIAS "_A3"
TARGET DOMAIN : G1(G1N1,G1N2) 5 rows,
                G2(G2N1,G2N2) 9 rows,
                G3(G3N1,G3N2) 4 rows
3 - SQL : DECLARE INSTANT TABLE "SESSION_SCHEMA"."$_NI_6"
      ( "L_PARTKEY" NUMBER(10, 0) )
COLUMN : LINEITEM.L_PARTKEY AS L_PARTKEY
SHARDED : LINEITEM.L_PARTKEY
TARGET DOMAIN : G1(G1N1,G1N2) 5 rows,
                G2(G2N1,G2N2) 9 rows,
                G3(G3N1,G3N2) 4 rows
4 - SQL :
  SELECT /*+ FULL( _A1 ) */
  "_A1"."L_PARTKEY"
  FROM "PUBLIC"."LINEITEM"@LOCAL AS "_A1"
  WHERE "_A1"."L_SHIPDATE" = :_V0
TARGET DOMAIN : G1(G1N1,G1N2) 7 rows,
                G2(G2N1,G2N2) 4 rows,
                G3(G3N1,G3N2) 7 rows

```



```

5 - HASH SHARD ( # 3 )
    READ COLUMN : LINEITEM.L_PARTKEY, LINEITEM.L_SHIPDATE
    PHYSICAL FILTER : LINEITEM.L_SHIPDATE = DATE'1998-12-01'
7 - TARGET : _A1.P_NAME
8 - JOINED COLUMN : _A1.P_NAME
9 - SORT KEY : "_A2.L_PARTKEY ASC NULLS LAST"
    READ KEY COLUMN : _A2.L_PARTKEY
10 - READ COLUMN : _A2.L_PARTKEY
11 - HASH SHARD ( # 3 )
    READ INDEX COLUMN : _A1.P_PARTKEY
    READ TABLE COLUMN : _A1.P_NAME
    MIN RANGE : _A1.P_PARTKEY = {_A2.L_PARTKEY}
    MAX RANGE : _A1.P_PARTKEY = {_A2.L_PARTKEY}
    FETCH ONE ROW
<<< end print plan

```

In [IDX 3] of the execution plan above, l\_partkey creates a pusher table which is a shard key and the data read from [IDX 4] is stored. Then, remote semi joined is performed for part and the pusher table.

### NO\_PUSHER\_SUBQ

If NO\_PUSHER\_SUBQ hint is specified, an optimizer transforms the subquery into the join statement which guarantees the same result. Then, it prevents to build the view or the table which was created by unnesting the subquery as a pusher table when performing the join in a remote.

Therefore, the remote unnest may not be available, and a sibling table can be built as a pusher table.

The following is an example of using NO\_PUSHER\_SUBQ hint.

```

\EXPLAIN PLAN
SELECT p_name
  FROM part
 WHERE p_partkey IN ( SELECT /*+ NO_PUSHER_SUBQ */
                    l_partkey
                    FROM lineitem
                    WHERE l_shipdate = date'1998-12-01'
                    );
>>> start print plan
< Execution Plan >
=====
|IDX|  NODE DESCRIPTION                               |          ROWS |
-----|-----|
| 0 |  SELECT STATEMENT                               |             18 |

```

```

| 1 | QUERY BLOCK ("$_QB_IDX_2") | 18 |
| 2 | HASH JOIN (SEMI) | 18 |
| 3 | PLAN BASED CLUSTER | LOCAL/REMOTE 200000 |
| 4 | TABLE ACCESS ("PART") | 66675 |
| 5 | HASH JOIN INSTANT (UNIQUE) | 18 |
| 6 | PLAN BASED CLUSTER | LOCAL/REMOTE 18 |
| 7 | TABLE ACCESS ("LINEITEM") | 7 |

```

```
=====
```

```

1 - TARGET : PART.P_NAME
2 - JOINED COLUMN : PART.P_NAME
3 - SQL : SELECT /*+ FULL( _A1 ) */
        "_A1"."P_PARTKEY", "_A1"."P_NAME"
        FROM "PUBLIC"."PART"@LOCAL AS "_A1"
        TARGET DOMAIN : G1(G1N1,G1N2) 66675 rows,
                        G2(G2N1,G2N2) 66664 rows,
                        G3(G3N1,G3N2) 66661 rows
4 - HASH SHARD ( # 3 )
    READ COLUMN : PART.P_PARTKEY, PART.P_NAME
5 - HASH KEY : LINEITEM.L_PARTKEY
    READ KEY COLUMN : LINEITEM.L_PARTKEY
    HASH FILTER : LINEITEM.L_PARTKEY = PART.P_PARTKEY
    FETCH ONE ROW
6 - SQL : SELECT /*+ FULL( _A1 ) */
        "_A1"."L_PARTKEY"
        FROM "PUBLIC"."LINEITEM"@LOCAL AS "_A1"
        WHERE "_A1"."L_SHIPDATE" = :_V0
    TARGET DOMAIN : G1(G1N1,G1N2) 7 rows,
                    G2(G2N1,G2N2) 4 rows,
                    G3(G3N1,G3N2) 7 rows
7 - HASH SHARD ( # 3 )
    READ COLUMN : LINEITEM.L_PARTKEY, LINEITEM.L_SHIPDATE
    PHYSICAL FILTER : LINEITEM.L_SHIPDATE = DATE'1998-12-01'

```

```
<<< end print plan
```

In the execution above, remote unnest is not performed, but local unnest is performed. In other words, it reads the data satisfying conditions from part and lineitem to G1, G2 and G3, then performs semi join in the current driver server.

The following is an example of using REMOTE\_UNNEST hint and NO\_PUSHER\_SUBQ hint together.

```

\EXPLAIN PLAN
SELECT p_name
  FROM part
 WHERE p_partkey IN ( SELECT /*+ REMOTE_UNNEST NO_PUSHER_SUBQ */
                      l_partkey
                      FROM lineitem
                      WHERE l_shipdate = date'1998-12-01'
                      );

```

```
>>> start print plan
```

```
< Execution Plan >
```

```

=====
|  IDX|  NODE DESCRIPTION                                |  ROWS |
-----|-----|-----|
|  0 | SELECT STATEMENT                                |    18 |
|  1 |   QUERY BLOCK ("$_QB_IDX_2")                    |    18 |
|  2 |     MULTIPLE CLUSTER                            | LOCAL/REMOTE 18 |
|  3 |       CLUSTER PUSHER ("$_NI_5")                 | 200000 |
|  4 |         PLAN BASED CLUSTER                       | LOCAL/REMOTE 200000 |
|  5 |           TABLE ACCESS ("PART")                 |   66675 |
|  6 |     SELECT STATEMENT                            |     7 |
|  7 |       QUERY BLOCK ("$_QB_IDX_2")                |     7 |
|  8 |         SORT INSTANT                             |     7 |
|  9 |           HASH JOIN (SEMI)                       |     7 |
| 10 |             PUSHER TABLE ACCESS ("$_NI_5" AS _A2) | 200000 |
| 11 |               HASH JOIN INSTANT (UNIQUE)         |     7 |
| 12 |                 TABLE ACCESS ("LINEITEM" AS _A1) |     7 |
=====

```

```
1 - TARGET : $_NI_5.P_NAME
```

```
2 - SQL :
```

```

SELECT /*+ KEEP_JOINED_TABLE
          USE_HASH_IN( _A1, 396 )
          FULL( _A2 )
          FULL( _A1 )
        */
   "_A2"."P_PARTKEY", "_A2"."P_NAME"
FROM ( "SESSION_SCHEMA"."$_NI_5"@LOCAL AS "_A2"
      SEMI JOIN
        "PUBLIC"."LINEITEM"@G1N1"|"G1N2"|
          "G2N1"|"G2N2"|
          "G3N1"|"G3N2"
      AS "_A1"

```

```

        ON "_A1"."L_PARTKEY" = "_A2"."P_PARTKEY"
        AND "_A1"."L_SHIPDATE" = :_V0
    ) ALIAS "_A3"
ORDER BY "_A2"."P_PARTKEY" ASC NULLS LAST
TARGET DOMAIN : G1(G1N1,G1N2) 7 rows,
                G2(G2N1,G2N2) 4 rows,
                G3(G3N1,G3N2) 7 rows
DISTINCT KEY GROUP
KEY GROUP : _$NI_5.P_PARTKEY
3 - SQL : DECLARE INSTANT TABLE "SESSION_SCHEMA"."_$NI_5"
        ( "P_PARTKEY" NUMBER(10, 0), "P_NAME" VARCHAR(55 OCTETS) )
COLUMN : PART.P_PARTKEY AS P_PARTKEY, PART.P_NAME AS P_NAME
CLONED
TARGET DOMAIN : G1(G1N1,G1N2) 200000 rows,
                G2(G2N1,G2N2) 200000 rows,
                G3(G3N1,G3N2) 200000 rows
4 - SQL :
SELECT /*+ FULL( _A1 ) */
        "_A1"."P_PARTKEY", "_A1"."P_NAME"
FROM "PUBLIC"."PART"@LOCAL AS "_A1"
TARGET DOMAIN : G1(G1N1,G1N2) 66675 rows,
                G2(G2N1,G2N2) 66664 rows,
                G3(G3N1,G3N2) 66661 rows
5 - HASH SHARD ( # 3 )
READ COLUMN : PART.P_PARTKEY, PART.P_NAME
7 - TARGET : _A2.P_PARTKEY, _A2.P_NAME
8 - SORT KEY : "_A2.P_PARTKEY ASC NULLS LAST"
RECORD COLUMN : _A2.P_NAME
READ KEY COLUMN : _A2.P_PARTKEY
READ RECORD COLUMN : _A2.P_NAME
9 - JOINED COLUMN : _A2.P_PARTKEY, _A2.P_NAME
10 - READ COLUMN : _A2.P_PARTKEY, _A2.P_NAME
11 - HASH KEY : _A1.L_PARTKEY
READ KEY COLUMN : _A1.L_PARTKEY
HASH FILTER : _A1.L_PARTKEY = _A2.P_PARTKEY
FETCH ONE ROW
12 - HASH SHARD ( # 3 )
READ COLUMN : _A1.L_PARTKEY, _A1.L_SHIPDATE
PHYSICAL FILTER : _A1.L_SHIPDATE = :_V0

```

<<< end print plan

In the execution plan above, it can not accumulate a subquery in a pusher table, so it creates part as a cloned pusher table, then performs remote join.

## PUSHER\_OUTQ

If PUSHER\_OUTQ hint is specified, an optimizer transforms the subquery into the join statement which guarantees the same result. Then, it accumulates a subquery of an outer table in a pusher table when performing the join in a remote.

The following is an example of using PUSHER\_OUTQ hint.

```
\EXPLAIN PLAN
SELECT p_name
  FROM part
 WHERE p_partkey IN ( SELECT /*+ PUSHER_OUTQ */
                      l_partkey
                      FROM lineitem
                      WHERE l_shipdate = date'1998-12-01'
                    );
```

< Execution Plan >

```
=====
|IDX|  NODE DESCRIPTION                               |          ROWS |
-----|-----|-----|
| 0 |  SELECT STATEMENT                               |             18 |
| 1 |    QUERY BLOCK ("$_QB_IDX_2")                   |             18 |
| 2 |      HASH JOIN (SEMI)                           |             18 |
| 3 |        PLAN BASED CLUSTER                       | LOCAL/REMOTE 200000 |
| 4 |          TABLE ACCESS ("PART")                 |             66675 |
| 5 |            HASH JOIN INSTANT (UNIQUE)           |             18 |
| 6 |              PLAN BASED CLUSTER                 | LOCAL/REMOTE 18 |
| 7 |                TABLE ACCESS ("LINEITEM")      |             7 |
=====
```

```

1 - TARGET : PART.P_NAME
2 - JOINED COLUMN : PART.P_NAME
3 - SQL : SELECT /*+ FULL( _A1 ) */
        "_A1"."P_PARTKEY", "_A1"."P_NAME"
        FROM "PUBLIC"."PART"@LOCAL AS "_A1"
        TARGET DOMAIN : G1(G1N1,G1N2) 66675 rows,
                        G2(G2N1,G2N2) 66664 rows,
                        G3(G3N1,G3N2) 66661 rows
4 - HASH SHARD ( # 3 )
   READ COLUMN : PART.P_PARTKEY, PART.P_NAME
5 - HASH KEY : LINEITEM.L_PARTKEY
```

```

        READ KEY COLUMN : LINEITEM.L_PARTKEY
        HASH FILTER : LINEITEM.L_PARTKEY = PART.P_PARTKEY
        FETCH ONE ROW
6 - SQL : SELECT /*+ FULL( _A1 ) */
        "_A1"."L_PARTKEY"
        FROM "PUBLIC"."LINEITEM"@LOCAL AS "_A1"
        WHERE "_A1"."L_SHIPDATE" = :_V0
        TARGET DOMAIN : G1(G1N1,G1N2) 7 rows,
        G2(G2N1,G2N2) 4 rows,
        G3(G3N1,G3N2) 7 rows
7 - HASH SHARD ( # 3 )
        READ COLUMN : LINEITEM.L_PARTKEY, LINEITEM.L_SHIPDATE
        PHYSICAL FILTER : LINEITEM.L_SHIPDATE = DATE'1998-12-01'
<<< end print plan

```

PUSHER\_OUTQ hint is applied when it is remote semi join.

If the cost of local semi join is better than that of remote semi join to which PUSHER\_OUTQ was applied, then local semi join is selected. Therefore, whether the hint is applied can not be checked in the execution plan.

Therefore, use REMOTE\_UNNEST hint and PUSHER\_OUTQ hint together as follows to check whether the hint is applied.

```

\EXPLAIN PLAN
SELECT p_name
  FROM part
 WHERE p_partkey IN ( SELECT /*+ REMOTE_UNNEST PUSHER_OUTQ */
                    l_partkey
                    FROM lineitem
                    WHERE l_shipdate = date'1998-12-01'
                    );
>>> start print plan
< Execution Plan >
=====
|  IDX  |  NODE DESCRIPTION                               |  ROWS  |
-----|-----|-----|
|   0   |  SELECT STATEMENT                               |        |
|   1   |    QUERY BLOCK ("$_QB_IDX_2")                   |        |
|   2   |      MULTIPLE CLUSTER                           | LOCAL/REMOTE 18 |
|   3   |        CLUSTER PUSHER ("$_NI_5")                |        |
|   4   |          PLAN BASED CLUSTER                     | LOCAL/REMOTE 200000 |
|   5   |            TABLE ACCESS ("PART")               |        |

```

```

| 6 |          SELECT STATEMENT                      |      7 |
| 7 |            QUERY BLOCK ("SQB_IDX_2")          |      7 |
| 8 |              SORT INSTANT                     |      7 |
| 9 |                HASH JOIN (SEMI)               |      7 |
|10 |                  PUSHER TABLE ACCESS ("_NI_5" AS _A2) | 200000 |
|11 |                    HASH JOIN INSTANT (UNIQUE) |      7 |
|12 |                      TABLE ACCESS ("LINEITEM" AS _A1) |      7 |

```

```

=====
1 - TARGET : _NI_5.P_NAME
2 - SQL : SELECT /*+ KEEP_JOINED_TABLE
          USE_HASH_IN( _A1, 396 )
          FULL( _A2 )
          FULL( _A1 )
          */
          "_A2"."P_PARTKEY", "_A2"."P_NAME"
FROM ( "SESSION_SCHEMA"."_NI_5"@LOCAL AS "_A2"
      SEMI JOIN
      "PUBLIC"."LINEITEM"@G1N1|"G1N2"|
          "G2N1|"G2N2"|
          "G3N1|"G3N2" AS "_A1"
      ON "_A1"."L_PARTKEY" = "_A2"."P_PARTKEY"
      AND "_A1"."L_SHIPDATE" = :_V0
      ) ALIAS "_A3"
ORDER BY "_A2"."P_PARTKEY" ASC NULLS LAST
TARGET DOMAIN : G1(G1N1,G1N2) 7 rows,
                G2(G2N1,G2N2) 4 rows,
                G3(G3N1,G3N2) 7 rows
DISTINCT KEY GROUP
KEY GROUP : _NI_5.P_PARTKEY
3 - SQL : DECLARE INSTANT TABLE "SESSION_SCHEMA"."_NI_5"
          ( "P_PARTKEY" NUMBER(10, 0), "P_NAME" VARCHAR(55 OCTETS) )
COLUMN : PART.P_PARTKEY AS P_PARTKEY, PART.P_NAME AS P_NAME
CLONED
TARGET DOMAIN : G1(G1N1,G1N2) 200000 rows,
                G2(G2N1,G2N2) 200000 rows,
                G3(G3N1,G3N2) 200000 rows
4 - SQL : SELECT /*+ FULL( _A1 ) */
          "_A1"."P_PARTKEY", "_A1"."P_NAME"
FROM "PUBLIC"."PART"@LOCAL AS "_A1"
TARGET DOMAIN : G1(G1N1,G1N2) 66675 rows,
                G2(G2N1,G2N2) 66664 rows,

```

```

                G3(G3N1,G3N2) 66661 rows
5  - HASH SHARD ( # 3 )
    READ COLUMN : PART.P_PARTKEY, PART.P_NAME
7  - TARGET : _A2.P_PARTKEY, _A2.P_NAME
8  - SORT KEY : "_A2.P_PARTKEY ASC NULLS LAST"
    RECORD COLUMN : _A2.P_NAME
    READ KEY COLUMN : _A2.P_PARTKEY
    READ RECORD COLUMN : _A2.P_NAME
9  - JOINED COLUMN : _A2.P_PARTKEY, _A2.P_NAME
10 - READ COLUMN : _A2.P_PARTKEY, _A2.P_NAME
11 - HASH KEY : _A1.L_PARTKEY
    READ KEY COLUMN : _A1.L_PARTKEY
    HASH FILTER : _A1.L_PARTKEY = _A2.P_PARTKEY
    FETCH ONE ROW
12 - HASH SHARD ( # 3 )
    READ COLUMN : _A1.L_PARTKEY, _A1.L_SHIPDATE
    PHYSICAL FILTER : _A1.L_SHIPDATE = :_V0

```

```
<<< end print plan
```

In the execution plan above, it performs remote semi join and builds part which is a table of an outer query as a pusher table.

### NO\_PUSHER\_OUTQ

If NO\_PUSHER\_OUTQ hint is specified, an optimizer transforms the subquery into the join statement which guarantees the same result. Then, it should not build an outer table of a subquery as a pusher table when performing the join in a remote.

The following is an example of using NO\_PUSHER\_OUTQ hint.

```

\EXPLAIN PLAN
SELECT p_name
  FROM part
 WHERE p_partkey IN ( SELECT /*+ NO_PUSHER_OUTQ */
                    l_partkey
                    FROM lineitem
                    WHERE l_shipdate = date'1998-12-01'
                    );

```

```
>>> start print plan
```

```
< Execution Plan >
```

```

=====
|  IDX  |  NODE DESCRIPTION                                |  ROWS  |
=====

```



```

| 0 | SELECT STATEMENT | 1 |
| 1 |   QUERY BLOCK ("SQB_IDX_2") | 1 |
| 2 |     SINGLE CLUSTER | LOCAL/REMOTE 1 |
| 3 |       CLUSTER PUSHER ("_NI_7") | 18 |
| 4 |         PLAN BASED CLUSTER | LOCAL/REMOTE 18 |
| 5 |           TABLE ACCESS ("LINEITEM") | 7 |
| 6 |     SELECT STATEMENT | 1 |
| 7 |       QUERY BLOCK ("SQB_IDX_2") | 1 |
| 8 |         AGGREGATION BY HASH | 1 |
| 9 |           NESTED JOIN (INVERTED SEMI) | 5 |
|10 |             SORT JOIN INSTANT (UNIQUE) | 5 |
|11 |               PUSHER TABLE ACCESS ("_NI_7" AS _A2) | 5 |
|12 |                 INDEX ACCESS ("PART" AS _A1, "PART_PK_INDEX") | (5) 5 |

```

```

=====
1 - TARGET : COUNT(*)
2 - SQL : SELECT /*+ KEEP_JOINED_TABLE
          USE_NL_IN( _A1 )
          FULL( _A2 )
          INDEX( _A1, "PUBLIC"."PART_PK_INDEX" )
          */
          COUNT(*)
          FROM ( "PUBLIC"."PART"@G1N1|"G1N2"|
                "G2N1"|"G2N2"|
                "G3N1"|"G3N2" AS "_A1"
                SEMI JOIN
                "SESSION_SCHEMA"."_NI_7"@LOCAL AS "_A2"
                ON "_A1"."P_PARTKEY" = "_A2"."L_PARTKEY"
                ) ALIAS "_A3"
          TARGET DOMAIN : G1(G1N1,G1N2) 1 rows,
                        G2(G2N1,G2N2) 1 rows,
                        G3(G3N1,G3N2) 1 rows
          RE-AGGREGATION
          AGGREGATION : SUM( COUNT(*) )
3 - SQL : DECLARE INSTANT TABLE "SESSION_SCHEMA"."_NI_7"
          ( "L_PARTKEY" NUMBER(10, 0) )
          COLUMN : LINEITEM.L_PARTKEY AS L_PARTKEY
          SHARDED : LINEITEM.L_PARTKEY
          TARGET DOMAIN : G1(G1N1,G1N2) 5 rows,
                        G2(G2N1,G2N2) 9 rows,
                        G3(G3N1,G3N2) 4 rows
4 - SQL : SELECT /*+ FULL( _A1 ) */

```

```

                "_A1"."L_PARTKEY"
            FROM "PUBLIC"."LINEITEM"@LOCAL AS "_A1"
            WHERE "_A1"."L_SHIPDATE" = :_V0
    TARGET DOMAIN : G1(G1N1,G1N2) 7 rows,
                  G2(G2N1,G2N2) 4 rows,
                  G3(G3N1,G3N2) 7 rows
5  - HASH SHARD ( # 3 )
    READ COLUMN : LINEITEM.L_PARTKEY, LINEITEM.L_SHIPDATE
    PHYSICAL FILTER : LINEITEM.L_SHIPDATE = DATE'1998-12-01'
7  - TARGET : COUNT(*)
8  - AGGREGATION : COUNT(*)
9  - JOINED COLUMN : NOTHING
10 - SORT KEY : "_A2.L_PARTKEY ASC NULLS LAST"
    READ KEY COLUMN : _A2.L_PARTKEY
11 - READ COLUMN : _A2.L_PARTKEY
12 - HASH SHARD ( # 3 )
    READ INDEX COLUMN : _A1.P_PARTKEY
    MIN RANGE : _A1.P_PARTKEY = {_A2.L_PARTKEY}
    MAX RANGE : _A1.P_PARTKEY = {_A2.L_PARTKEY}
    FETCH ONE ROW
<<< end print plan

```

In the execution plan above, it does not build part which is a table of an outer query as a pusher table, but it builds lineitem which is a table whose subquery is unnested as a pusher table.

## <unnest merge hints>

If a subquery is unnested as a view, then the hint defines whether to merge the view.

### MERGE\_SUBQ

If a subquery is unnested as a view, then the hint merges the view.

The following is an example of using MERGE\_SUBQ hint.

```

\EXPLAIN PLAN
SELECT
    o_orderdate,
    o_totalprice
FROM orders
WHERE o_orderkey IN (
    SELECT /*+ MERGE_SUBQ */
        l_orderkey
    FROM lineitem

```

```

                GROUP BY l_orderkey
            )
;
no rows selected.
>>> start print plan
< Execution Plan >
=====
|  IDX  |  NODE DESCRIPTION                                |
-----|-----|
|   0   |  SELECT STATEMENT                                |
|   1   |    QUERY BLOCK ("QB_IDX_2")                      |
|   2   |      INLINE_VIEW ("V3")                          |
|   3   |        QUERY BLOCK ("QB_IDX_6")                  |
|   4   |          GROUP HASH INSTANT                       |
|   5   |            HASH JOIN (INNER JOIN)                |
|   6   |              TABLE ACCESS ("ORDERS")            |
|   7   |                HASH JOIN INSTANT                 |
|   8   |                  INDEX ACCESS ("LINEITEM", "LINEITEM_PK_INDEX") |
=====
1 - TARGET : $V3.O_ORDERDATE, $V3.O_TOTALPRICE
2 - COLUMN : O_TOTALPRICE AS O_TOTALPRICE, O_ORDERDATE AS O_ORDERDATE
3 - TARGET : MAX( ORDERS.O_TOTALPRICE ) AS O_TOTALPRICE, MAX( ORDERS.O_ORDERDATE ) AS
O_ORDERDATE
4 - GROUP KEY : LINEITEM.L_ORDERKEY, ORDERS.$PHYSICAL_ROWID
   RECORD COLUMN : MAX( ORDERS.O_TOTALPRICE ), MAX( ORDERS.O_ORDERDATE )
   READ RECORD COLUMN : MAX( ORDERS.O_TOTALPRICE ), MAX( ORDERS.O_ORDERDATE )
5 - JOINED COLUMN : LINEITEM.L_ORDERKEY, ORDERS.$PHYSICAL_ROWID, ORDERS.O_TOTALPRICE,
ORDERS.O_ORDERDATE
6 - READ COLUMN : ORDERS.O_ORDERKEY, ORDERS.O_TOTALPRICE, ORDERS.O_ORDERDATE
7 - HASH KEY : LINEITEM.L_ORDERKEY
   READ KEY COLUMN : LINEITEM.L_ORDERKEY
   HASH FILTER : LINEITEM.L_ORDERKEY = ORDERS.O_ORDERKEY
8 - READ INDEX COLUMN : LINEITEM.L_ORDERKEY
<<< end print plan

```

In the execution plan above, if a subquery is unnested as a view, then the complex view merging is performed for the view.

### NO\_MERGE\_SUBQ

If a subquery is unnested as a view, then the hint does not merge the view.

The following is an example of using NO\_MERGE\_SUBQ hint.

```

\EXPLAIN PLAN
SELECT
    o_orderdate,
    o_totalprice
FROM orders
WHERE o_orderkey IN (
    SELECT /*+ NO_MERGE_SUBQ */
        l_orderkey
    FROM   lineitem
    GROUP BY l_orderkey
)
;
>>> start print plan
< Execution Plan >
=====
|  IDX  |  NODE DESCRIPTION  |
-----|-----|
|   0   |  SELECT STATEMENT  |
|   1   |  QUERY BLOCK ("QB_IDX_2") |
|   2   |    NESTED JOIN (INNER JOIN) |
|   3   |      INLINE_VIEW ("V4") |
|   4   |        QUERY BLOCK ("QB_IDX_6") |
|   5   |          GROUP |
|   6   |            INDEX ACCESS ("LINEITEM", "LINEITEM_PK_INDEX") |
|   7   |            INDEX ACCESS ("ORDERS", "ORDERS_PK_INDEX") |
=====
1 - TARGET : ORDERS.O_ORDERDATE, ORDERS.O_TOTALPRICE
2 - JOINED COLUMN : ORDERS.O_ORDERDATE, ORDERS.O_TOTALPRICE
3 - COLUMN : LINEITEM.L_ORDERKEY AS L_ORDERKEY
4 - TARGET : LINEITEM.L_ORDERKEY
5 - GROUP KEY : LINEITEM.L_ORDERKEY
6 - READ INDEX COLUMN : LINEITEM.L_ORDERKEY
7 - READ INDEX COLUMN : ORDERS.O_ORDERKEY
   READ TABLE COLUMN : ORDERS.O_TOTALPRICE, ORDERS.O_ORDERDATE
   MIN RANGE : ORDERS.O_ORDERKEY = {V4.L_ORDERKEY}
   MAX RANGE : ORDERS.O_ORDERKEY = {V4.L_ORDERKEY}
   FETCH ONE ROW
<<< end print plan

```

In the execution plan above, if a subquery is unnested as a view, then the nested join is performed for the view as it is.

## <transitive closure hints>

Those hints determine whether to apply the join transitive closure method.

For more information about join transitive closure, refer to [Join Transitive Closure](#).

### TRANSITIVE\_CLOSURE

If TRANSITIVE\_CLOSURE hint is specified, join transitive closure is applied during the rewriter process.

The following is an example of using TRANSITIVE\_CLOSURE hint.

```
\EXPLAIN PLAN
SELECT /*+ TRANSITIVE_CLOSURE */
      l_extendedprice * (1 - l_discount) - ps_supplycost * l_quantity as amount
FROM part,
      lineitem,
      partsupp
WHERE ps_suppkey = l_suppkey
      AND ps_partkey = l_partkey
      AND p_partkey = l_partkey
      AND p_name like '%green%';
>>> start print plan
< Execution Plan >
=====
|  IDX  |  NODE DESCRIPTION                                     |  ROWS  |
-----|-----|-----|
|  0  | SELECT STATEMENT                                     | 319404 |
|  1  |  QUERY BLOCK ("SQB_IDX_2")                           | 319404 |
|  2  |    NESTED JOIN (INNER JOIN)                          | 319404 |
|  3  |      NESTED JOIN (INNER JOIN)                        | 42656  |
|  4  |        TABLE ACCESS ("PART")                        | 10664  |
|  5  |          INDEX ACCESS ("PARTSUPP", "PARTSUPP_PARTKEY_FK") | 42656  |
|  6  |            INDEX ACCESS ("LINEITEM", "LINEITEM_PARTKEY_SUPPKEY_FK") | 319404 |
=====
      1 - TARGET : ( LINEITEM.L_EXTENDEDPRICE * ( 1 - LINEITEM.L_DISCOUNT ) ) - (
PARTSUPP.PS_SUPPLYCOST * LINEITEM.L_QUANTITY ) AS AMOUNT
      2 - JOINED COLUMN : LINEITEM.L_EXTENDEDPRICE, LINEITEM.L_DISCOUNT,
PARTSUPP.PS_SUPPLYCOST, LINEITEM.L_QUANTITY
      3 - JOINED COLUMN : PART.P_PARTKEY, PARTSUPP.PS_SUPPKEY, PARTSUPP.PS_SUPPLYCOST
      4 - READ COLUMN : PART.P_PARTKEY, PART.P_NAME
          LOGICAL FILTER : PART.P_NAME LIKE '%green%'
      5 - READ INDEX COLUMN : PARTSUPP.PS_PARTKEY
```



```

| 0 |SELECT STATEMENT                                | 319404 |
| 1 |  QUERY BLOCK ("SQB_IDX_2")                       | 319404 |
| 2 |    HASH JOIN (INNER JOIN)                       | 319404 |
| 3 |      TABLE ACCESS ("PARTSUPP")                 | 800000 |
| 4 |        HASH JOIN INSTANT                         | 319404 |
| 5 |          NESTED JOIN (INNER JOIN)               | 319404 |
| 6 |            TABLE ACCESS ("PART")               | 10664  |
| 7 |              INDEX ACCESS ("LINEITEM","LINEITEM_PARTKEY_SUPPKEY_FK")| 319404 |
=====
1 - TARGET : ( LINEITEM.L_EXTENDEDPRICE * ( 1 - LINEITEM.L_DISCOUNT ) ) - (
PARTSUPP.PS_SUPPLYCOST * LINEITEM.L_QUANTITY ) AS AMOUNT
2 - JOINED COLUMN : LINEITEM.L_EXTENDEDPRICE, LINEITEM.L_DISCOUNT,
PARTSUPP.PS_SUPPLYCOST, LINEITEM.L_QUANTITY
3 - READ COLUMN : PARTSUPP.PS_PARTKEY, PARTSUPP.PS_SUPPKEY, PARTSUPP.PS_SUPPLYCOST
4 - HASH KEY : LINEITEM.L_PARTKEY, LINEITEM.L_SUPPKEY
   RECORD COLUMN : LINEITEM.L_EXTENDEDPRICE, LINEITEM.L_DISCOUNT, LINEITEM.L_QUANTITY
   READ KEY COLUMN : LINEITEM.L_PARTKEY, LINEITEM.L_SUPPKEY, LINEITEM.L_EXTENDEDPRICE,
LINEITEM.L_DISCOUNT, LINEITEM.L_QUANTITY
   HASH FILTER : LINEITEM.L_PARTKEY = PARTSUPP.PS_PARTKEY AND LINEITEM.L_SUPPKEY =
PARTSUPP.PS_SUPPKEY
5 - JOINED COLUMN : LINEITEM.L_PARTKEY, LINEITEM.L_SUPPKEY, LINEITEM.L_EXTENDEDPRICE,
LINEITEM.L_DISCOUNT, LINEITEM.L_QUANTITY
6 - READ COLUMN : PART.P_PARTKEY, PART.P_NAME
   LOGICAL FILTER : PART.P_NAME LIKE '%green%'
7 - READ INDEX COLUMN : LINEITEM.L_PARTKEY, LINEITEM.L_SUPPKEY
   READ TABLE COLUMN : LINEITEM.L_QUANTITY, LINEITEM.L_EXTENDEDPRICE,
LINEITEM.L_DISCOUNT
   MIN RANGE : LINEITEM.L_PARTKEY = {PART.P_PARTKEY}
   MAX RANGE : LINEITEM.L_PARTKEY = {PART.P_PARTKEY}
<<< end print plan

```

In the example above, the example and the query are as same as those of TRANSITIVE\_CLOSURE hint, but the execution plan is different from that of TRANSITIVE\_CLOSURE hint. It is because the execution plan is created with only the join condition described by the user.

If statistics information is correct, then the time to perform the query in the execution plan above may take longer than the time to perform the example of TRANSITIVE\_CLOSURE hint. It is because its intermediate results of join are more.

However, if the number of lineitem rows are much fewer due to an incorrect statistics information, then it is more effected to create the execution plan with only the join condition specified by the user. Therefore, use NO\_TRANSITIVE\_CLOSURE hint in this case.

## <view hints>

### <view merge hints>

Those hints determine whether to apply the view merging method during the rewriter process.

#### **MERGE(view\_name)**

If MERGE(view\_name) hint is specified, the view with view\_name is merged with an outer query.

The following is an example of using MERGE(view\_name) hint.

```

CREATE OR REPLACE VIEW v_nation
(
  v_nationkey,
  v_nation_name,
  v_region_name
)
AS SELECT n_nationkey,
         n_name,
         r_name
   FROM nation,
        region
  WHERE n_regionkey = r_regionkey;
\EXPLAIN PLAN
SELECT /*+ MERGE(v_nation) */
       v_nation_name,
       count(*)
   FROM customer,
        v_nation
  WHERE c_nationkey = v_nationkey
        AND v_region_name = 'ASIA'
GROUP BY v_nation_name ;
>>> start print plan
< Execution Plan >
=====
|  IDX  |  NODE DESCRIPTION                                |
-----|-----|-----|
|    0  |  SELECT STATEMENT                                |
|    1  |    QUERY BLOCK ("$_QB_IDX_2")                    |
|    2  |      GROUP HASH INSTANT                          |
|    3  |        NESTED JOIN (INNER JOIN)                  |
|    4  |          NESTED JOIN (INNER JOIN)                |

```



```

| 5 |          TABLE ACCESS ("REGION")          |
| 6 |          INDEX ACCESS ("NATION", "NATION_REGIONKEY_FK") |
| 7 |          INDEX ACCESS ("CUSTOMER", "CUSTOMER_NATIONKEY_FK") |
=====
1 - TARGET : NATION.N_NAME, COUNT(*)
2 - GROUP KEY : NATION.N_NAME
   RECORD COLUMN : COUNT(*)
   READ KEY COLUMN : NATION.N_NAME
   READ RECORD COLUMN : COUNT(*)
3 - JOINED COLUMN : NATION.N_NAME
4 - JOINED COLUMN : NATION.N_NATIONKEY, NATION.N_NAME
5 - READ COLUMN : REGION.R_REGIONKEY, REGION.R_NAME
   PHYSICAL FILTER : REGION.R_NAME = 'ASIA'
6 - READ INDEX COLUMN : NATION.N_REGIONKEY
   READ TABLE COLUMN : NATION.N_NATIONKEY, NATION.N_NAME
   MIN RANGE : NATION.N_REGIONKEY = {REGION.R_REGIONKEY}
   MAX RANGE : NATION.N_REGIONKEY = {REGION.R_REGIONKEY}
7 - READ INDEX COLUMN : CUSTOMER.C_NATIONKEY
   MIN RANGE : CUSTOMER.C_NATIONKEY = {NATION.N_NATIONKEY}
   MAX RANGE : CUSTOMER.C_NATIONKEY = {NATION.N_NATIONKEY}
<<< end print plan

```

In the execution plan above, v\_nation is merged with an outer query.

### **NO\_MERGE(view\_name)**

If NO\_MERGE(view\_name) hint is specified, the view with view\_name is not merged with an outer query.

The following is an example of using NO\_MERGE(view\_name) hint.

```

CREATE OR REPLACE VIEW v_nation
(
  v_nationkey,
  v_nation_name,
  v_region_name
)
AS SELECT n_nationkey,
         n_name,
         r_name
FROM nation,
     region
WHERE n_regionkey = r_regionkey;

```

- The view merging method is not applied.

```
\EXPLAIN PLAN
```

```
SELECT /*+ NO_MERGE(v_nation) */
      v_nation_name,
      count(*)
FROM customer,
      v_nation
WHERE c_nationkey = v_nationkey
      AND v_region_name = 'ASIA'
```

```
GROUP BY v_nation_name ;
```

```
>>> start print plan
```

```
< Execution Plan >
```

```
=====
|  IDX  |  NODE DESCRIPTION  |
-----|-----|
|   0   |  SELECT STATEMENT  |
|   1   |    QUERY BLOCK ("SQB_IDX_2")  |
|   2   |      GROUP HASH INSTANT  |
|   3   |        NESTED JOIN (INNER JOIN)  |
|   4   |          VIEW ("V_NATION")  |
|   5   |            QUERY BLOCK ("SQB_IDX_7")  |
|   6   |              NESTED JOIN (INNER JOIN)  |
|   7   |                TABLE ACCESS ("REGION")  |
|   8   |                  INDEX ACCESS ("NATION", "NATION_REGIONKEY_FK")  |
|   9   |                    INDEX ACCESS ("CUSTOMER", "CUSTOMER_NATIONKEY_FK")  |
=====

  1 - TARGET : V_NATION.V_NATION_NAME, COUNT(*)
  2 - GROUP KEY : V_NATION.V_NATION_NAME
      RECORD COLUMN : COUNT(*)
      READ KEY COLUMN : V_NATION.V_NATION_NAME
      READ RECORD COLUMN : COUNT(*)
  3 - JOINED COLUMN : V_NATION.V_NATION_NAME
  4 - COLUMN : V_NATIONKEY AS V_NATIONKEY, V_NATION_NAME AS V_NATION_NAME, V_REGION_NAME
AS V_REGION_NAME
  5 - TARGET : NATION.N_NATIONKEY AS V_NATIONKEY, NATION.N_NAME AS V_NATION_NAME,
REGION.R_NAME AS V_REGION_NAME
  6 - JOINED COLUMN : NATION.N_NATIONKEY, NATION.N_NAME, REGION.R_NAME
  7 - READ COLUMN : REGION.R_REGIONKEY, REGION.R_NAME
      PHYSICAL FILTER : REGION.R_NAME = 'ASIA'
  8 - READ INDEX COLUMN : NATION.N_REGIONKEY
```

```

        READ TABLE COLUMN : NATION.N_NATIONKEY, NATION.N_NAME
        MIN RANGE : NATION.N_REGIONKEY = {REGION.R_REGIONKEY}
        MAX RANGE : NATION.N_REGIONKEY = {REGION.R_REGIONKEY}
9  -  READ INDEX COLUMN : CUSTOMER.C_NATIONKEY
        MIN RANGE : CUSTOMER.C_NATIONKEY = {V_NATION.V_NATIONKEY}
        MAX RANGE : CUSTOMER.C_NATIONKEY = {V_NATION.V_NATIONKEY}
<<< end print plan

```

In the execution plan above, v\_nation is not merged with an outer query, but it exists as it is in view form.

## <push view predicate hints>

Those hints either push the view-related join predicate into the view or prevent the pushing.

### PUSH\_PRED

If PUSH\_PRED hint is specified, it pushes all join predicates related to views listed in a from clause into the view.

The following is an example of using PUSH\_PRED hint.

```

CREATE OR REPLACE VIEW v_nation
(
    v_nationkey,
    v_nation_name,
    v_region_name
)
AS SELECT n_nationkey,
        n_name,
        r_name
    FROM nation,
        region
    WHERE n_regionkey = r_regionkey;
\EXPLAIN PLAN
SELECT /*+ PUSH_PRED */
    v_nation_name,
    count(*)
    FROM customer,
        v_nation
    WHERE c_nationkey = v_nationkey
        AND v_region_name = 'ASIA'
GROUP BY v_nation_name;
>>> start print plan
< Execution Plan >

```

```

=====
|  IDX  |  NODE DESCRIPTION                                |
-----
|   0   |  SELECT STATEMENT                                |
|   1   |    QUERY BLOCK ("SQB_IDX_2")                     |
|   2   |      GROUP HASH INSTANT                          |
|   3   |        NESTED JOIN (INNER JOIN)                  |
|   4   |          INDEX ACCESS ("CUSTOMER", "CUSTOMER_NATIONKEY_FK") |
|   5   |            VIEW ("V_NATION")                      |
|   6   |              QUERY BLOCK ("SQB_IDX_7")           |
|   7   |                NESTED JOIN (INNER JOIN)          |
|   8   |                  INDEX ACCESS ("NATION", "NATION_PK_INDEX") |
|   9   |                    INDEX ACCESS ("REGION", "REGION_PK_INDEX") |
=====

1 - TARGET : V_NATION.V_NATION_NAME, COUNT(*)
2 - GROUP KEY : V_NATION.V_NATION_NAME
   RECORD COLUMN : COUNT(*)
   READ KEY COLUMN : V_NATION.V_NATION_NAME
   READ RECORD COLUMN : COUNT(*)

3 - JOINED COLUMN : V_NATION.V_NATION_NAME
4 - READ INDEX COLUMN : CUSTOMER.C_NATIONKEY
5 - COLUMN : V_NATIONKEY AS V_NATIONKEY, V_NATION_NAME AS V_NATION_NAME, V_REGION_NAME
AS V_REGION_NAME
6 - TARGET : NATION.N_NATIONKEY AS V_NATIONKEY, NATION.N_NAME AS V_NATION_NAME,
REGION.R_NAME AS V_REGION_NAME
7 - JOINED COLUMN : NATION.N_NATIONKEY, NATION.N_NAME, REGION.R_NAME
8 - READ INDEX COLUMN : NATION.N_NATIONKEY
   READ TABLE COLUMN : NATION.N_NAME, NATION.N_REGIONKEY
   MIN RANGE : NATION.N_NATIONKEY = {CUSTOMER.C_NATIONKEY}
   MAX RANGE : NATION.N_NATIONKEY = {CUSTOMER.C_NATIONKEY}
   FETCH ONE ROW
9 - READ INDEX COLUMN : REGION.R_REGIONKEY
   READ TABLE COLUMN : REGION.R_NAME
   MIN RANGE : REGION.R_REGIONKEY = {NATION.N_REGIONKEY}
   MAX RANGE : REGION.R_REGIONKEY = {NATION.N_REGIONKEY}
   PHYSICAL TABLE FILTER : REGION.R_NAME = 'ASIA'
   FETCH ONE ROW

<<< end print plan

```

In the execution plan above, c\_nationkey = v\_nationkey is used by being pushed into the view.

## NO\_PUSH\_PRED

If NO\_PUSH\_PRED hint is specified, it prevents pushing all join predicates related to views listed in a from clause into the view.

The following is an example of using NO\_PUSH\_PRED hint.

```

CREATE OR REPLACE VIEW v_nation
(
  v_nationkey,
  v_nation_name,
  v_region_name
)
AS SELECT n_nationkey,
         n_name,
         r_name
   FROM nation,
        region
  WHERE n_regionkey = r_regionkey;
\EXPLAIN PLAN
SELECT /*+ NO_PUSH_PRED */
       v_nation_name,
       count(*)
   FROM customer,
        v_nation
  WHERE c_nationkey = v_nationkey
        AND v_region_name = 'ASIA'
GROUP BY v_nation_name;
>>> start print plan
< Execution Plan >
=====
|  IDX  |  NODE DESCRIPTION                                |
-----|-----|
|   0   |  SELECT STATEMENT                                |
|   1   |    QUERY BLOCK ("SQB_IDX_2")                    |
|   2   |      GROUP HASH INSTANT                         |
|   3   |        NESTED JOIN (INNER JOIN)                 |
|   4   |          VIEW ("V_NATION")                      |
|   5   |            QUERY BLOCK ("SQB_IDX_7")            |
|   6   |              NESTED JOIN (INNER JOIN)          |
|   7   |                TABLE ACCESS ("REGION")        |
|   8   |                  INDEX ACCESS ("NATION", "NATION_REGIONKEY_FK") |

```

```

| 9 | INDEX ACCESS ("CUSTOMER", "CUSTOMER_NATIONKEY_FK") |
=====
1 - TARGET : V_NATION.V_NATION_NAME, COUNT(*)
2 - GROUP KEY : V_NATION.V_NATION_NAME
   RECORD COLUMN : COUNT(*)
   READ KEY COLUMN : V_NATION.V_NATION_NAME
   READ RECORD COLUMN : COUNT(*)
3 - JOINED COLUMN : V_NATION.V_NATION_NAME
4 - COLUMN : V_NATIONKEY AS V_NATIONKEY, V_NATION_NAME AS V_NATION_NAME, V_REGION_NAME
AS V_REGION_NAME
5 - TARGET : NATION.N_NATIONKEY AS V_NATIONKEY, NATION.N_NAME AS V_NATION_NAME,
REGION.R_NAME AS V_REGION_NAME
6 - JOINED COLUMN : NATION.N_NATIONKEY, NATION.N_NAME, REGION.R_NAME
7 - READ COLUMN : REGION.R_REGIONKEY, REGION.R_NAME
   PHYSICAL FILTER : REGION.R_NAME = 'ASIA'
8 - READ INDEX COLUMN : NATION.N_REGIONKEY
   READ TABLE COLUMN : NATION.N_NATIONKEY, NATION.N_NAME
   MIN RANGE : NATION.N_REGIONKEY = {REGION.R_REGIONKEY}
   MAX RANGE : NATION.N_REGIONKEY = {REGION.R_REGIONKEY}
9 - READ INDEX COLUMN : CUSTOMER.C_NATIONKEY
   MIN RANGE : CUSTOMER.C_NATIONKEY = {V_NATION.V_NATIONKEY}
   MAX RANGE : CUSTOMER.C_NATIONKEY = {V_NATION.V_NATIONKEY}
<<< end print plan

```

In the execution plan above, `c_nationkey = v_nationkey` is used outside of the view.

### **PUSH\_PRED( view\_name[ [ , ] view\_name ] )**

If `PUSH_PRED( view_name[ [ , ] view_name ] )` hint is specified, it pushes all join predicates related to views listed in a from clause into the view.

The following is an example of using `PUSH_PRED( view_name[ [ , ] view_name ] )` hint.

```

CREATE OR REPLACE VIEW v_nation
(
  v_nationkey,
  v_nation_name,
  v_region_name
)
AS SELECT n_nationkey,
         n_name,
         r_name
FROM nation,

```

```

        region
    WHERE n_regionkey = r_regionkey;
\EXPLAIN PLAN
SELECT /*+ PUSH_PRED(v_nation) */
    v_nation_name,
    count(*)
FROM customer,
    v_nation
WHERE c_nationkey = v_nationkey
    AND v_region_name = 'ASIA'
GROUP BY v_nation_name;
>>> start print plan
< Execution Plan >
=====
|  IDX  |  NODE DESCRIPTION  |
-----|-----|
|   0   |  SELECT STATEMENT  |
|   1   |    QUERY BLOCK (" $QB_IDX_2" )  |
|   2   |      GROUP HASH INSTANT  |
|   3   |        NESTED JOIN (INNER JOIN)  |
|   4   |          INDEX ACCESS ("CUSTOMER", "CUSTOMER_NATIONKEY_FK")  |
|   5   |            VIEW ("V_NATION")  |
|   6   |              QUERY BLOCK (" $QB_IDX_7" )  |
|   7   |                NESTED JOIN (INNER JOIN)  |
|   8   |                  INDEX ACCESS ("NATION", "NATION_PK_INDEX")  |
|   9   |                    INDEX ACCESS ("REGION", "REGION_PK_INDEX")  |
=====

1 - TARGET : V_NATION.V_NATION_NAME, COUNT(*)
2 - GROUP KEY : V_NATION.V_NATION_NAME
   RECORD COLUMN : COUNT(*)
   READ KEY COLUMN : V_NATION.V_NATION_NAME
   READ RECORD COLUMN : COUNT(*)
3 - JOINED COLUMN : V_NATION.V_NATION_NAME
4 - READ INDEX COLUMN : CUSTOMER.C_NATIONKEY
5 - COLUMN : V_NATIONKEY AS V_NATIONKEY, V_NATION_NAME AS V_NATION_NAME, V_REGION_NAME
AS V_REGION_NAME
6 - TARGET : NATION.N_NATIONKEY AS V_NATIONKEY, NATION.N_NAME AS V_NATION_NAME,
REGION.R_NAME AS V_REGION_NAME
7 - JOINED COLUMN : NATION.N_NATIONKEY, NATION.N_NAME, REGION.R_NAME
8 - READ INDEX COLUMN : NATION.N_NATIONKEY
   READ TABLE COLUMN : NATION.N_NAME, NATION.N_REGIONKEY

```

```

        MIN RANGE : NATION.N_NATIONKEY = {CUSTOMER.C_NATIONKEY}
        MAX RANGE : NATION.N_NATIONKEY = {CUSTOMER.C_NATIONKEY}
    FETCH ONE ROW
9  -  READ INDEX COLUMN : REGION.R_REGIONKEY
    READ TABLE COLUMN : REGION.R_NAME
        MIN RANGE : REGION.R_REGIONKEY = {NATION.N_REGIONKEY}
        MAX RANGE : REGION.R_REGIONKEY = {NATION.N_REGIONKEY}
        PHYSICAL TABLE FILTER : REGION.R_NAME = 'ASIA'
    FETCH ONE ROW
<<< end print plan

```

### NO\_PUSH\_PRED( view\_name [ [ , ] view\_name ] )

If NO\_PUSH\_PRED( view\_name [ [ , ] view\_name ] ) hint is specified, it prevents pushing all join predicates related to views listed in a from clause into the view.

The following is an example of using NO\_PUSH\_PRED( view\_name [ [ , ] view\_name ] ) hint.

```

CREATE OR REPLACE VIEW v_nation
(
    v_nationkey,
    v_nation_name,
    v_region_name
)
AS SELECT n_nationkey,
        n_name,
        r_name
    FROM nation,
        region
    WHERE n_regionkey = r_regionkey;
\EXPLAIN PLAN
SELECT /*+ NO_PUSH_PRED(v_nation) */
    v_nation_name,
    count(*)
    FROM customer,
        v_nation
    WHERE c_nationkey = v_nationkey
        AND v_region_name = 'ASIA'
GROUP BY v_nation_name;
>>> start print plan
< Execution Plan >

```

```
=====
```



```

|  IDX  |  NODE DESCRIPTION  |
-----|-----|
|  0  |  SELECT STATEMENT  |
|  1  |  QUERY BLOCK ("QB_IDX_2") |
|  2  |  GROUP HASH INSTANT |
|  3  |  NESTED JOIN (INNER JOIN) |
|  4  |  VIEW ("V_NATION") |
|  5  |  QUERY BLOCK ("QB_IDX_7") |
|  6  |  NESTED JOIN (INNER JOIN) |
|  7  |  TABLE ACCESS ("REGION") |
|  8  |  INDEX ACCESS ("NATION", "NATION_REGIONKEY_FK") |
|  9  |  INDEX ACCESS ("CUSTOMER", "CUSTOMER_NATIONKEY_FK") |
=====
1 - TARGET : V_NATION.V_NATION_NAME, COUNT(*)
2 - GROUP KEY : V_NATION.V_NATION_NAME
   RECORD COLUMN : COUNT(*)
   READ KEY COLUMN : V_NATION.V_NATION_NAME
   READ RECORD COLUMN : COUNT(*)
3 - JOINED COLUMN : V_NATION.V_NATION_NAME
4 - COLUMN : V_NATIONKEY AS V_NATIONKEY, V_NATION_NAME AS V_NATION_NAME, V_REGION_NAME
AS V_REGION_NAME
5 - TARGET : NATION.N_NATIONKEY AS V_NATIONKEY, NATION.N_NAME AS V_NATION_NAME,
REGION.R_NAME AS V_REGION_NAME
6 - JOINED COLUMN : NATION.N_NATIONKEY, NATION.N_NAME, REGION.R_NAME
7 - READ COLUMN : REGION.R_REGIONKEY, REGION.R_NAME
   PHYSICAL FILTER : REGION.R_NAME = 'ASIA'
8 - READ INDEX COLUMN : NATION.N_REGIONKEY
   READ TABLE COLUMN : NATION.N_NATIONKEY, NATION.N_NAME
   MIN RANGE : NATION.N_REGIONKEY = {REGION.R_REGIONKEY}
   MAX RANGE : NATION.N_REGIONKEY = {REGION.R_REGIONKEY}
9 - READ INDEX COLUMN : CUSTOMER.C_NATIONKEY
   MIN RANGE : CUSTOMER.C_NATIONKEY = {V_NATION.V_NATIONKEY}
   MAX RANGE : CUSTOMER.C_NATIONKEY = {V_NATION.V_NATIONKEY}
<<< end print plan

```

## Operation Hint

Those hints are applied per each relation.

## <access path hints>

It defines how to access a single table.

### FULL( table\_name )

If FULL( table\_name ) hint is specified, then an optimizer performs the table full scan for the specified table.

Only one table\_name can be specified, and it should exist in <from clause>.

The following is an example of using FULL( table\_name ) hint.

```

SELECT count(*) FROM nation;
COUNT(*)
-----
         25
1 row selected.
\EXPLAIN PLAN
SELECT /*+ FULL( nation ) */
       n_name
FROM nation
WHERE n_nationkey < 10;
>>> start print plan
< Execution Plan >
=====
|  IDX  |  NODE DESCRIPTION                                |  ROWS  |
=====
|   0   |  SELECT STATEMENT                                |    10   |
|   1   |    QUERY BLOCK ("$_QB_IDX_2")                    |    10   |
|   2   |      TABLE ACCESS ("NATION")                    |    10   |
=====
      1 -  TARGET : NATION.N_NAME
      2 -  READ COLUMN : NATION.N_NATIONKEY, NATION.N_NAME
          PHYSICAL FILTER : NATION.N_NATIONKEY < 10
<<< end print plan

```

In the example above, n\_nationkey is a primary key column so the index access is available. However the performance of the table access is better than that of the index access when selecting ten results from a small table whose nation table has 25 rows only.

## INDEX( table\_name [ , ] [ index\_name [ [ , ] index\_name ] ] )

If INDEX( table\_name [ , ] [ index\_name [ [ , ] index\_name ] ] ) hint is specified, then an optimizer performs the index scan for the specified table. In this case, the index with the best cost is selected among listed indexes. If index\_name is not specified, then the index with the best cost is selected among all indexes in the table.

One or more table\_name can be specified, and it should exist in <from clause>.

An index name can be specified one or more, or it can be omitted. And it should be index\_name which exists in the table corresponding to table\_name.

The following is an example of using INDEX( table\_name ) hint.

```
\EXPLAIN PLAN
  SELECT /*+ INDEX( nation ) */
        n_nationkey,
        n_name
  FROM nation
  WHERE n_nationkey < 10
 ORDER BY n_nationkey;

>>> start print plan
< Execution Plan >

=====
|  IDX  |  NODE DESCRIPTION                                |  ROWS  |
=====
|  0  |  SELECT STATEMENT                                |    10  |
|  1  |  QUERY BLOCK ("SQB_IDX_2")                       |    10  |
|  2  |  INDEX ACCESS ("NATION", "NATION_PK_INDEX")      |    10  |
=====

   1 - TARGET : NATION.N_NATIONKEY, NATION.N_NAME
   2 - READ INDEX COLUMN : NATION.N_NATIONKEY
      READ TABLE COLUMN : NATION.N_NAME
      MAX RANGE : NATION.N_NATIONKEY < 10

<<< end print plan
```

In the example above, a nation table is a small table which has 25 rows, and only 10 rows are selected among those. Therefore, the performance of the table access is better than that of the index access. However, the result of an index access is as if it is ordered by even though the order by is not separately performed, so the order by can be omitted. Therefore, an index access may be better in this case.

**NO\_INDEX( table\_name [ , ] [ index\_name [ [ , ] index\_name ] ] )**

If NO\_INDEX( table\_name [ , ] [ index\_name [ [ , ] index\_name ] ] ) hint is specified, then an optimizer prevents events using the specified index. If index\_name is not specified, then none of the index is used. In other words, it does not perform the index scan.

Only one table\_name can be specified, and it should exist in <from clause>.

An index name can be specified one or more, or it can be omitted. And it should be index\_name which exists in the table corresponding to table\_name.

The following is an example of using NO\_INDEX( table\_name ) hint.

```
\EXPLAIN PLAN
  SELECT /*+ NO_INDEX( nation ) */
        n_nationkey,
        n_name
  FROM nation
  WHERE n_nationkey < 10
ORDER BY n_nationkey;
>>> start print plan
< Execution Plan >
```

IDX	NODE DESCRIPTION	ROWS
0	SELECT STATEMENT	10
1	QUERY BLOCK ("\$_QB_IDX_2")	10
2	SORT INSTANT	10
3	TABLE ACCESS ("NATION")	10

```

1 - TARGET : NATION.N_NATIONKEY, NATION.N_NAME
2 - SORT KEY : "NATION.N_NATIONKEY ASC NULLS LAST"
   RECORD COLUMN : NATION.N_NAME
   READ KEY COLUMN : NATION.N_NATIONKEY
   READ RECORD COLUMN : NATION.N_NAME
3 - READ COLUMN : NATION.N_NATIONKEY, NATION.N_NAME
   PHYSICAL FILTER : NATION.N_NATIONKEY < 10
<<< end print plan
```

In the example above, the table access is performed because using any index is prevented.

## INDEX\_FORWARD( table\_name [ , ] [ index\_name [ [ , ] index\_name ] ] )

INDEX\_FORWARD( table\_name [ , ] [ index\_name [ [ , ] index\_name ] ] ) hint is as same as INDEX(table\_name [ , ] [ index\_name [ [ , ] index\_name ] ] ) hint.

It performs the forward scan for the index. Therefore, if the index was created in an ascending order, then it outputs the result in an ascending order. If the index was created in a descending order, then it outputs the result in a descending order.

The following is an example of using INDEX\_FORWARD( table\_name ) hint.

```
\EXPLAIN PLAN
  SELECT /*+ INDEX_FORWARD( nation ) */
         n_nationkey,
         n_name
  FROM nation
 WHERE n_nationkey < 10
 ORDER BY n_nationkey ASC;
>>> start print plan
< Execution Plan >

=====
|  IDX  |  NODE DESCRIPTION                               |  ROWS  |
-----|-----|-----|
|    0  |  SELECT STATEMENT                               |    10  |
|    1  |    QUERY BLOCK ("$$QB_IDX_2")                   |    10  |
|    2  |      INDEX ACCESS ("NATION", "NATION_PK_INDEX") |    10  |
=====

  1 - TARGET : NATION.N_NATIONKEY, NATION.N_NAME
  2 - READ INDEX COLUMN : NATION.N_NATIONKEY
     READ TABLE COLUMN : NATION.N_NAME
     MAX RANGE : NATION.N_NATIONKEY < 10

<<< end print plan
```

In the example above, if NATION\_PK\_INDEX was created in an ascending order, then separate sorting for ORDER BY is not required when performing the forward scan for the index.

## INDEX\_BACKWARD( table\_name [ , ] [ index\_name [ [ , ] index\_name ] ] )

It performs the backward scan for the index. Therefore, if the index was created in an ascending order, then it outputs the result in a descending order. If the index was created in a descending order, then it outputs the result in an ascending order.

The syntax rule of INDEX\_BACKWARD( table\_name [ , ] [ index\_name [ [ , ] index\_name ] ] ) is as same as that of INDEX(table\_name [ , ] [ index\_name [ [ , ] index\_name ] ] ) hint.

The following is an example of using INDEX\_BACKWARD( table\_name ) hint.

```

\EXPLAIN PLAN
  SELECT /*+ INDEX_BACKWARD( nation ) */
        n_nationkey,
        n_name
  FROM nation
  WHERE n_nationkey < 10
ORDER BY n_nationkey DESC;
>>> start print plan
< Execution Plan >

=====
|  IDX  |  NODE DESCRIPTION                                |  ROWS  |
-----|-----|-----|
|   0   |  SELECT STATEMENT                                |   10   |
|   1   |    QUERY BLOCK ("$$QB_IDX_2")                    |   10   |
|   2   |      INDEX ACCESS ("NATION", "NATION_PK_INDEX")  |   10   |
=====

  1 - TARGET : NATION.N_NATIONKEY, NATION.N_NAME
  2 - READ INDEX COLUMN : NATION.N_NATIONKEY
     READ TABLE COLUMN : NATION.N_NAME
     MAX RANGE : NATION.N_NATIONKEY < 10
<<< end print plan

```

In the example above, if NATION\_PK\_INDEX was created in an ascending order, then separate sorting for ORDER BY is not required when performing the backward scan for the index.

## INDEX\_ASC( table\_name [ , ] [ index\_name [ [ , ] index\_name ] ] )

INDEX\_ASC( table\_name [ , ] [ index\_name [ [ , ] index\_name ] ] ) hint is as same as INDEX(table\_name [ , ] [index\_name[[,] index\_name]]) hint.

It performs the forward scan for the index. Therefore, if the index was created in an ascending order, then it outputs the result in an ascending order. If the index was created in a descending order, then it outputs the result in a descending order.

The following is an example of using INDEX\_ASC( table\_name ) hint.

```

\EXPLAIN PLAN
  SELECT /*+ INDEX_ASC( nation ) */
        n_nationkey,
        n_name
  FROM nation

```



```

| 0 | SELECT STATEMENT | 10 |
| 1 | QUERY BLOCK ("QB_IDX_2") | 10 |
| 2 | INDEX ACCESS ("NATION", "NATION_PK_INDEX") | 10 |
=====
1 - TARGET : NATION.N_NATIONKEY, NATION.N_NAME
2 - READ INDEX COLUMN : NATION.N_NATIONKEY
   READ TABLE COLUMN : NATION.N_NAME
   MAX RANGE : NATION.N_NATIONKEY < 10
<<< end print plan

```

In the example above, if NATION\_PK\_INDEX was created in an ascending order, then separate sorting for ORDER BY is not required when performing the backward scan for the index.

## INDEX\_COMBINE( table\_name [ , ] [ index\_name [ [ , ] index\_name ] ] )

If INDEX\_COMBINE( table\_name [ , ] [ index\_name [ [ , ] index\_name ] ] ) hint is specified, then an optimizer separates OR statements in the specified table, performs the index scan and merges the results. In this case, the index with the best cost is selected among listed indexes when determining each index scan. If index\_name is not specified, then the index with the best cost is selected among all indexes in the table. Therefore, each different index can be used according to OR statements.

When specifying INDEX\_COMBINE hint, a table name should exist in <from clause> and the index name should be the one existing in the table.

The or statement should exist in the condition to scan the table for performing INDEX\_COMBINE hint. If the or statement does not exist, then the optimizer ignores the hint.

The following is an example of using INDEX\_COMBINE( table\_name ) hint.

```

\EXPLAIN PLAN
SELECT /*+ INDEX_COMBINE( orders ) */
   o_orderstatus
FROM orders
WHERE o_orderkey = 1 OR o_custkey = 1;
>>> start print plan
< Execution Plan >
=====
| IDX | NODE DESCRIPTION | ROWS |
-----|-----|-----|
| 0 | SELECT STATEMENT | 7 |
| 1 | QUERY BLOCK ("QB_IDX_2") | 7 |
| 2 | CONCAT (Compare RID) | 7 |
| 3 | INDEX ACCESS ("ORDERS", "ORDERS_PK_INDEX") | 1 |
| 4 | INDEX ACCESS ("ORDERS", "ORDERS_CUSTKEY_FK") | 6 |

```



```

=====
1 - TARGET : ORDERS.O_ORDERSTATUS
2 - CONCAT COLUMN : ORDERS.$PHYSICAL_ROWID, ORDERS.O_ORDERSTATUS
3 - READ INDEX COLUMN : ORDERS.O_ORDERKEY
   READ TABLE COLUMN : ORDERS.O_ORDERSTATUS
   MIN RANGE : ORDERS.O_ORDERKEY = 1
   MAX RANGE : ORDERS.O_ORDERKEY = 1
   FETCH ONE ROW
4 - READ INDEX COLUMN : ORDERS.O_CUSTKEY
   READ TABLE COLUMN : ORDERS.O_ORDERSTATUS
   MIN RANGE : ORDERS.O_CUSTKEY = 1
   MAX RANGE : ORDERS.O_CUSTKEY = 1

```

```
<<< end print plan
```

In the example above, the index scan is not available with the entire `o_orderkey = 1` OR `o_custkey = 1` condition, so the performance may become slow. Therefore, separate OR statement and perform the index scan for each condition (`o_orderkey = 1` and `o_custkey = 1`), then merge the results to upgrade the performance.

## IN\_KEY\_RANGE( table\_name [ , ] [ index\_name [ [ , ] index\_name ] ] )

If `IN_KEY_RANGE( table_name [ , ] [ index_name [ [ , ] index_name ] ] )` hint is specified, then an optimizer performs the IN key range scan for the specified table. In this case, the index with the best cost is selected among specified indexes. If `index_name` is not specified, then the index with the best cost is selected among all indexes in the table.

However, a filter which is capable of the IN key range is required for applying `IN_KEY_RANGE( table_name [ , ] [ index_name [ [ , ] index_name ] ] )` hint.

Filter conditions for IN key range are as follows.

e.g. `( col1, col2 ) IN ( (val1, val2), (val3, val4) )`

- `IN` or `=ANY List Function Filter` should exist in WHERE clause.
- `col1` and `col2` should be base columns. In other words, they should not be operations nor are functions.
- `(val1, val3)` corresponding to `col1` can be converted to a single data type, `(val2, val4)` corresponding to `col2` can be converted to a single data type.

The following is an example of using `IN_KEY_RANGE` hint.

```

\EXPLAIN PLAN
SELECT /*+ IN_KEY_RANGE( orders ) */
       o_orderstatus
FROM orders

```

```

WHERE o_orderkey > 500 AND o_custkey IN ( 1, 10, 100, 1000, 10000 );
< Execution Plan >
=====
|  IDX  |  NODE DESCRIPTION                                |  ROWS  |
-----|-----|-----|
|    0  |  SELECT STATEMENT                                |    91  |
|    1  |    QUERY BLOCK ("QB_IDX_2")                      |    91  |
|    2  |      INDEX ACCESS ("ORDERS", "ORDERS_CUSTKEY_FK") |    91  |
=====

1 - TARGET : ORDERS.O_ORDERSTATUS
2 - READ INDEX COLUMN : ORDERS.O_CUSTKEY
   READ TABLE COLUMN : ORDERS.O_ORDERKEY, ORDERS.O_ORDERSTATUS
   IN KEY RANGE
   MIN RANGE : ORDERS.O_CUSTKEY = ?
   MAX RANGE : ORDERS.O_CUSTKEY = ?
   PHYSICAL TABLE FILTER : ORDERS.O_ORDERKEY > 500
<<< end print plan

```

In the execution plan above, the IN key range scan is performed.

## ROWID( table\_name )

If ROWID( table\_name ) hint is specified, then an optimizer performs the rowid scan for the specified table. The table name should exist in <from clause> when specifying ROWID hint.

The equal condition using ROWID should exist in the table to apply ROWID hint. If this condition does not exist, then an optimizer ignores this hint.

The following is an example of using ROWID hint.

```

\EXPLAIN PLAN
SELECT /*+ ROWID( orders ) */
      o_orderstatus
FROM orders
WHERE rowid = 'AAAAAAAAAYFAACAAACGjAAA';
>>> start print plan
< Execution Plan >
=====
|  IDX  |  NODE DESCRIPTION                                |  ROWS  |
-----|-----|-----|
|    0  |  SELECT STATEMENT                                |    1  |
|    1  |    QUERY BLOCK ("QB_IDX_2")                      |    1  |
=====

```

```

| 2 | ROWID ACCESS ("ORDERS") | 1 |
=====
1 - TARGET : ORDERS.O_ORDERSTATUS
2 - READ COLUMN : ORDERS.O_ORDERSTATUS
   ROWID FILTER : ORDERS.ROWID = 'AAAAAAAYFAAACAACGjAAA'
<<< end print plan

```

## <join hints>

### <join order hints>

Those hints define how to perform the join ordering.

#### ORDERED

If ORDERED hint is specified, then an optimizer orders to perform joining in an order described in <from clause> when performing the join ordering.

If a user knows how many number of rows satisfying the join conditions and the best join order, then the user can decrease the join ordering cost by using ORDERED hint.

The following is an example of using ORDERED hint.

```

\EXPLAIN PLAN
SELECT /*+ ORDERED */
   l_orderkey,
   ROUND( sum(l_extendedprice*(1-l_discount)), 2) as revenue,
   o_orderdate,
   o_shippriority
FROM   customer,
       orders,
       lineitem
WHERE  c_mktsegment = 'BUILDING'
       AND c_custkey = o_custkey
       AND l_orderkey = o_orderkey
       AND o_orderdate < date '1995-03-15'
       AND l_shipdate > date '1995-03-15'
GROUP BY l_orderkey,
         o_orderdate,
         o_shippriority;
>>> start print plan
< Execution Plan >
=====

```

```

|  IDX  |  NODE DESCRIPTION                                |  ROWS  |
-----|-----|-----|
|  0  |  SELECT STATEMENT                                |  11620  |
|  1  |    QUERY BLOCK ("SQB_IDX_2")                    |  11620  |
|  2  |      GROUP HASH INSTANT                        |  11620  |
|  3  |        NESTED JOIN (INNER JOIN)                |  30519  |
|  4  |          NESTED JOIN (INNER JOIN)              |  147126 |
|  5  |            TABLE ACCESS ("CUSTOMER")          |  30142  |
|  6  |              INDEX ACCESS ("ORDERS", "ORDERS_CUSTKEY_FK") |  147126 |
|  7  |                INDEX ACCESS ("LINEITEM", "LINEITEM_ORDERKEY_FK") |  30519  |
-----|-----|-----|
      1 - TARGET : LINEITEM.L_ORDERKEY, ROUND(SUM( LINEITEM.L_EXTENDEDPRI
LINEITEM.L_DISCOUNT ) ),2) AS REVENUE, ORDERS.O_ORDERDATE, ORDERS.O_SHIP
      2 - GROUP KEY : LINEITEM.L_ORDERKEY, ORDERS.O_ORDERDATE, ORDERS.O_SHIP
      RECORD COLUMN : SUM( LINEITEM.L_EXTENDEDPRI * ( 1 - LINEITEM.L_DISC
      READ KEY COLUMN : LINEITEM.L_ORDERKEY, ORDERS.O_ORDERDATE, ORDERS.O_SHIP
      READ RECORD COLUMN : SUM( LINEITEM.L_EXTENDEDPRI * ( 1 - LINEITEM.L_DISC
      3 - JOINED COLUMN : LINEITEM.L_ORDERKEY, ORDERS.O_ORDERDATE, ORDERS.O_SHIP
LINEITEM.L_EXTENDEDPRI, LINEITEM.L_DISCOUNT
      4 - JOINED COLUMN : ORDERS.O_ORDERKEY, ORDERS.O_ORDERDATE, ORDERS.O_SHIP
      5 - READ COLUMN : CUSTOMER.C_CUSTKEY, CUSTOMER.C_MKTSEGMENT
      PHYSICAL FILTER : CUSTOMER.C_MKTSEGMENT = 'BUILDING'
      6 - READ INDEX COLUMN : ORDERS.O_CUSTKEY
      READ TABLE COLUMN : ORDERS.O_ORDERKEY, ORDERS.O_ORDERDATE, ORDERS.O_SHIP
      MIN RANGE : ORDERS.O_CUSTKEY = {CUSTOMER.C_CUSTKEY}
      MAX RANGE : ORDERS.O_CUSTKEY = {CUSTOMER.C_CUSTKEY}
      PHYSICAL TABLE FILTER : ORDERS.O_ORDERDATE < DATE'1995-03-15'
      7 - READ INDEX COLUMN : LINEITEM.L_ORDERKEY
      READ TABLE COLUMN : LINEITEM.L_EXTENDEDPRI, LINEITEM.L_DISCOUNT,
LINEITEM.L_SHIPDATE
      MIN RANGE : LINEITEM.L_ORDERKEY = {ORDERS.O_ORDERKEY}
      MAX RANGE : LINEITEM.L_ORDERKEY = {ORDERS.O_ORDERKEY}
      PHYSICAL TABLE FILTER : LINEITEM.L_SHIPDATE > DATE'1995-03-15'
<<< end print plan

```

### ORDERING( table\_name [ , table\_name [ , table\_name [ LEFT | RIGHT ] ] ] )

If ORDERING( table\_name [ , table\_name [ , table\_name [ LEFT | RIGHT ] ] ] ) hint is specified, then an optimizer orders to perform joining in an order described in the hint when performing the join ordering.

A locating option can not be specified for the first and the second tables, but it can be specified from the third table. Location options are LEFT and RIGHT. LEFT places the table on the left node (outer node) of t

he join, and RIGHT places the table on the right node (inner node) of the join. If a locating option is not used, then the location is determined by the cost estimation.

The following is an example of using ORDERING hint.

```
\EXPLAIN PLAN
SELECT /*+ ORDERING( customer, orders, lineitem RIGHT ) */
      l_orderkey,
      ROUND( sum(l_extendedprice*(1-l_discount)), 2) as revenue,
      o_orderdate,
      o_shippriority
FROM   lineitem,
       orders,
       customer
WHERE  c_mktsegment = 'BUILDING'
      AND c_custkey = o_custkey
      AND l_orderkey = o_orderkey
      AND o_orderdate < date '1995-03-15'
      AND l_shipdate > date '1995-03-15'
GROUP BY l_orderkey,
         o_orderdate,
         o_shippriority;
>>> start print plan
< Execution Plan >
=====
|  IDX  |  NODE DESCRIPTION                                |  ROWS  |
|-----|-----|-----|
|  0  |  SELECT STATEMENT                                |  11620  |
|  1  |    QUERY BLOCK ("$_QB_IDX_2")                    |  11620  |
|  2  |      GROUP HASH INSTANT                          |  11620  |
|  3  |        NESTED JOIN (INNER JOIN)                  |  30519  |
|  4  |          NESTED JOIN (INNER JOIN)                 |  147126 |
|  5  |            TABLE ACCESS ("CUSTOMER")             |  30142  |
|  6  |              INDEX ACCESS ("ORDERS", "ORDERS_CUSTKEY_FK") |  147126 |
|  7  |                INDEX ACCESS ("LINEITEM", "LINEITEM_ORDERKEY_FK") |  30519  |
|-----|-----|-----|
1 - TARGET : LINEITEM.L_ORDERKEY, ROUND(SUM( LINEITEM.L_EXTENDEDPRICE * ( 1 -
LINEITEM.L_DISCOUNT ) ),2) AS REVENUE, ORDERS.O_ORDERDATE, ORDERS.O_SHIPRIORITY
2 - GROUP KEY : LINEITEM.L_ORDERKEY, ORDERS.O_ORDERDATE, ORDERS.O_SHIPRIORITY
   RECORD COLUMN : SUM( LINEITEM.L_EXTENDEDPRICE * ( 1 - LINEITEM.L_DISCOUNT ) )
   READ KEY COLUMN : LINEITEM.L_ORDERKEY, ORDERS.O_ORDERDATE, ORDERS.O_SHIPRIORITY
   READ RECORD COLUMN : SUM( LINEITEM.L_EXTENDEDPRICE * ( 1 - LINEITEM.L_DISCOUNT ) )
```

```

3 - JOINED COLUMN : LINEITEM.L_ORDERKEY, ORDERS.O_ORDERDATE, ORDERS.O_SHIPPRIORITY,
LINEITEM.L_EXTENDEDPRICE, LINEITEM.L_DISCOUNT
4 - JOINED COLUMN : ORDERS.O_ORDERKEY, ORDERS.O_ORDERDATE, ORDERS.O_SHIPPRIORITY
5 - READ COLUMN : CUSTOMER.C_CUSTKEY, CUSTOMER.C_MKTSEGMENT
    PHYSICAL FILTER : CUSTOMER.C_MKTSEGMENT = 'BUILDING'
6 - READ INDEX COLUMN : ORDERS.O_CUSTKEY
    READ TABLE COLUMN : ORDERS.O_ORDERKEY, ORDERS.O_ORDERDATE, ORDERS.O_SHIPPRIORITY
    MIN RANGE : ORDERS.O_CUSTKEY = {CUSTOMER.C_CUSTKEY}
    MAX RANGE : ORDERS.O_CUSTKEY = {CUSTOMER.C_CUSTKEY}
    PHYSICAL TABLE FILTER : ORDERS.O_ORDERDATE < DATE'1995-03-15'
7 - READ INDEX COLUMN : LINEITEM.L_ORDERKEY
    READ TABLE COLUMN : LINEITEM.L_EXTENDEDPRICE, LINEITEM.L_DISCOUNT,
LINEITEM.L_SHIPDATE
    MIN RANGE : LINEITEM.L_ORDERKEY = {ORDERS.O_ORDERKEY}
    MAX RANGE : LINEITEM.L_ORDERKEY = {ORDERS.O_ORDERKEY}
    PHYSICAL TABLE FILTER : LINEITEM.L_SHIPDATE > DATE'1995-03-15'
<<< end print plan

```

### LEADING( table\_name [ [ , ] table\_name ] )

If LEADING( table\_name [ [ , ] table\_name ] ) hint is specified, then an optimizer orders to perform joining in an order described in the hint when performing the join ordering. Unlike an ORDERING hint, LEADING( table\_name [ [ , ] table\_name ] ) hint can not specify the location of tables, but it can only specify the order of tables participating in the join ordering.

The following is an example of using LEADING hint.

```

\EXPLAIN PLAN
SELECT /*+ LEADING( customer, orders, lineitem ) */
    l_orderkey,
    ROUND( sum(l_extendedprice*(1-l_discount)), 2) as revenue,
    o_orderdate,
    o_shippriority
FROM    lineitem,
        orders,
        customer
WHERE   c_mktsegment = 'BUILDING'
        AND c_custkey = o_custkey
        AND l_orderkey = o_orderkey
        AND o_orderdate < date '1995-03-15'
        AND l_shipdate > date '1995-03-15'
GROUP BY l_orderkey,

```

```
o_orderdate,
o_shippriority;
```

```
>>> start print plan
```

```
< Execution Plan >
```

```
=====
|  IDX  |  NODE DESCRIPTION                                |  ROWS  |
-----
|  0  |  SELECT STATEMENT                                |  11620  |
|  1  |    QUERY BLOCK ("SQB_IDX_2")                     |  11620  |
|  2  |      GROUP HASH INSTANT                          |  11620  |
|  3  |        NESTED JOIN (INNER JOIN)                  |  30519  |
|  4  |          NESTED JOIN (INNER JOIN)                 |  147126 |
|  5  |            TABLE ACCESS ("CUSTOMER")            |  30142  |
|  6  |              INDEX ACCESS ("ORDERS", "ORDERS_CUSTKEY_FK") |  147126 |
|  7  |                INDEX ACCESS ("LINEITEM", "LINEITEM_ORDERKEY_FK") |  30519  |
=====
```

```
1 - TARGET : LINEITEM.L_ORDERKEY, ROUND(SUM( LINEITEM.L_EXTENDEDPRICE * ( 1 -
LINEITEM.L_DISCOUNT ) ),2) AS REVENUE, ORDERS.O_ORDERDATE, ORDERS.O_SHIPRIORITY
2 - GROUP KEY : LINEITEM.L_ORDERKEY, ORDERS.O_ORDERDATE, ORDERS.O_SHIPRIORITY
   RECORD COLUMN : SUM( LINEITEM.L_EXTENDEDPRICE * ( 1 - LINEITEM.L_DISCOUNT ) )
   READ KEY COLUMN : LINEITEM.L_ORDERKEY, ORDERS.O_ORDERDATE, ORDERS.O_SHIPRIORITY
   READ RECORD COLUMN : SUM( LINEITEM.L_EXTENDEDPRICE * ( 1 - LINEITEM.L_DISCOUNT ) )
3 - JOINED COLUMN : LINEITEM.L_ORDERKEY, ORDERS.O_ORDERDATE, ORDERS.O_SHIPRIORITY,
LINEITEM.L_EXTENDEDPRICE, LINEITEM.L_DISCOUNT
4 - JOINED COLUMN : ORDERS.O_ORDERKEY, ORDERS.O_ORDERDATE, ORDERS.O_SHIPRIORITY
5 - READ COLUMN : CUSTOMER.C_CUSTKEY, CUSTOMER.C_MKTSEGMENT
   PHYSICAL FILTER : CUSTOMER.C_MKTSEGMENT = 'BUILDING'
6 - READ INDEX COLUMN : ORDERS.O_CUSTKEY
   READ TABLE COLUMN : ORDERS.O_ORDERKEY, ORDERS.O_ORDERDATE, ORDERS.O_SHIPRIORITY
   MIN RANGE : ORDERS.O_CUSTKEY = {CUSTOMER.C_CUSTKEY}
   MAX RANGE : ORDERS.O_CUSTKEY = {CUSTOMER.C_CUSTKEY}
   PHYSICAL TABLE FILTER : ORDERS.O_ORDERDATE < DATE'1995-03-15'
7 - READ INDEX COLUMN : LINEITEM.L_ORDERKEY
   READ TABLE COLUMN : LINEITEM.L_EXTENDEDPRICE, LINEITEM.L_DISCOUNT,
LINEITEM.L_SHIPDATE
   MIN RANGE : LINEITEM.L_ORDERKEY = {ORDERS.O_ORDERKEY}
   MAX RANGE : LINEITEM.L_ORDERKEY = {ORDERS.O_ORDERKEY}
   PHYSICAL TABLE FILTER : LINEITEM.L_SHIPDATE > DATE'1995-03-15'
```

```
<<< end print plan
```

## <join operation hints>

### USE\_HASH( table\_name [ [ , ] table\_name ] )

If USE\_HASH( table\_name [ [ , ] table\_name ] ) hint is specified, then an optimizer selects hash join when determining the join operation of the join in which table\_name participates.

One or more table should be specified, and the same tables can not be specified more than two. If <join operation hints> already exists in the specified table, then the hint is ignored. Also, if each different join operation hint is specified in two tables participating in join, then the hint specified in a right node(inner node) is preferentially applied.

The hint is applied only when a equi-join condition exists even though USE\_HASH hint is specified. If a join condition which is capable of hash join does not exist, then an optimizer selects the best join operation through a cost estimation.

The following is an example of using USE\_HASH( table\_name [ [ , ] table\_name ] ) hint.

```
\EXPLAIN PLAN
SELECT /*+ USE_HASH( orders ) */
      c_name,
      o_orderdate,
      o_orderstatus
FROM   customer,
      orders
WHERE  c_custkey = o_custkey
      AND o_orderdate >= date '1995-03-15'
      AND o_orderdate < date '1995-03-15' + interval '1' month;
>>> start print plan
< Execution Plan >
=====
|  IDX  |  NODE DESCRIPTION                                |  ROWS  |
-----|-----|-----|
|   0   |  SELECT STATEMENT                                |  19343  |
|   1   |    QUERY BLOCK (" $QB_IDX_2" )                   |  19343  |
|   2   |      HASH JOIN (INNER JOIN)                      |  19343  |
|   3   |        TABLE ACCESS ("CUSTOMER")                | 150000  |
|   4   |          HASH JOIN INSTANT                        |  19343  |
|   5   |            TABLE ACCESS ("ORDERS")              |  19343  |
=====
1 - TARGET : CUSTOMER.C_NAME, ORDERS.O_ORDERDATE, ORDERS.O_ORDERSTATUS
2 - JOINED COLUMN : CUSTOMER.C_NAME, ORDERS.O_ORDERDATE, ORDERS.O_ORDERSTATUS
3 - READ COLUMN : CUSTOMER.C_CUSTKEY, CUSTOMER.C_NAME
4 - HASH KEY : ORDERS.O_CUSTKEY
```





```

| 0 | SELECT STATEMENT | 19343 | ... |
| 1 |   QUERY BLOCK ("Q$QB_IDX_2") | 19343 | ... |
| 2 |     HASH JOIN (INNER JOIN) | 19343 | ... |
| 3 |       TABLE ACCESS ("CUSTOMER") | 150000 | ... |
| 4 |         HASH JOIN INSTANT | 19343 | ... |
| 5 |           TABLE ACCESS ("ORDERS") | 19343 | ... |
=====
1 - TARGET : CUSTOMER.C_NAME, ORDERS.O_ORDERDATE, ORDERS.O_ORDERSTATUS
2 - JOINED COLUMN : CUSTOMER.C_NAME, ORDERS.O_ORDERDATE, ORDERS.O_ORDERSTATUS
3 - READ COLUMN : CUSTOMER.C_CUSTKEY, CUSTOMER.C_NAME
4 - HASH KEY : ORDERS.O_CUSTKEY
   RECORD COLUMN : ORDERS.O_ORDERDATE, ORDERS.O_ORDERSTATUS
   READ KEY COLUMN : ORDERS.O_CUSTKEY, ORDERS.O_ORDERDATE, ORDERS.O_ORDERSTATUS
   HASH FILTER : ORDERS.O_CUSTKEY = CUSTOMER.C_CUSTKEY
   HASH BUCKET COUNT : 17430
5 - READ COLUMN : ORDERS.O_CUSTKEY, ORDERS.O_ORDERSTATUS, ORDERS.O_ORDERDATE
   PHYSICAL FILTER : ORDERS.O_ORDERDATE < DATE'1995-03-15' + CAST( '1' AS
INTERVAL(MONTH) ) AND ORDERS.O_ORDERDATE >= DATE'1995-03-15'
<<< end print plan

```

In the example above, the hash bucket count in an output of orders participating in the join is specified as many as the number of distinct values.

### USE\_HASH\_IN( alias )

If USE\_HASH\_IN( alias ) hint is specified, then an optimizer selects hash join when determining the join operation of the join in which the alias participates. Then it places the alias on the right(inner) of the join.

If <join operation hints> already exists in the specified alias, then the hint is ignored. Also, if each different join operation hint is specified in two tables participating in join, then the hint specified in a right node(inner node) is preferentially applied.

A table name, a table alias name, a view name, a view alias name and a join alias name can be an alias.

The following is an example of using USE\_HASH\_IN( alias ) hint.

```

--# hash join
\EXPLAIN PLAN
  SELECT /*+ USE_HASH_IN( orders ) */
         c_name,
         o_orderdate,
         o_orderstatus
  FROM   customer,

```

```

        orders
WHERE   c_custkey = o_custkey
        AND o_orderdate >= date '1995-03-15'
        AND o_orderdate < date '1995-03-15' + interval '1' month;
>>> start print plan
< Execution Plan >
=====
|  IDX  |  NODE DESCRIPTION                                |  ROWS  |
-----|-----|-----|
|   0   |  SELECT STATEMENT                                |  19343  |
|   1   |    QUERY BLOCK ("$_QB_IDX_2")                    |  19343  |
|   2   |      HASH JOIN (INNER JOIN)                      |  19343  |
|   3   |        TABLE ACCESS ("CUSTOMER")                | 150000  |
|   4   |          HASH JOIN INSTANT                        |  19343  |
|   5   |            TABLE ACCESS ("ORDERS")               |  19343  |
=====
1 - TARGET : CUSTOMER.C_NAME, ORDERS.O_ORDERDATE, ORDERS.O_ORDERSTATUS
2 - JOINED COLUMN : CUSTOMER.C_NAME, ORDERS.O_ORDERDATE, ORDERS.O_ORDERSTATUS
3 - READ COLUMN : CUSTOMER.C_CUSTKEY, CUSTOMER.C_NAME
4 - HASH KEY : ORDERS.O_CUSTKEY
   RECORD COLUMN : ORDERS.O_ORDERDATE, ORDERS.O_ORDERSTATUS
   READ KEY COLUMN : ORDERS.O_CUSTKEY, ORDERS.O_ORDERDATE, ORDERS.O_ORDERSTATUS
   HASH FILTER : ORDERS.O_CUSTKEY = CUSTOMER.C_CUSTKEY
5 - READ COLUMN : ORDERS.O_CUSTKEY, ORDERS.O_ORDERSTATUS, ORDERS.O_ORDERDATE
   PHYSICAL FILTER : ORDERS.O_ORDERDATE < DATE'1995-03-15' + CAST( '1' AS
INTERVAL(MONTH) ) AND ORDERS.O_ORDERDATE >= DATE'1995-03-15'
<<< end print plan

```

The following is an example of using USE\_HASH\_IN( alias ) hint by using join alias.

```

\EXPLAIN PLAN
SELECT /*+ USE_HASH_IN( j1 ) */
        l_orderkey,
        ROUND( sum(l_extendedprice*(1-l_discount)), 2) as revenue,
        o_orderdate,
        o_shippriority
FROM   ( customer INNER JOIN orders ON c_mktsegment = 'BUILDING'
        AND c_custkey = o_custkey
        AND o_orderdate < date '1995-03-15'
        ) ALIAS j1
INNER JOIN lineitem ON l_orderkey = o_orderkey

```

```

                                AND l_shipdate > date '1995-03-15'
GROUP BY l_orderkey,
         o_orderdate,
         o_shippriority;
>>> start print plan
< Execution Plan >
=====
|  IDX  |  NODE DESCRIPTION                               |  ROWS  |
-----|-----|-----|
|  0  |  SELECT STATEMENT                               |  11620 |
|  1  |    QUERY BLOCK ("SQB_IDX_2")                   |  11620 |
|  2  |      GROUP HASH INSTANT                        |  11620 |
|  3  |        HASH JOIN (INNER JOIN)                 |  30519 |
|  4  |          TABLE ACCESS ("LINEITEM")           | 3241776 |
|  5  |            HASH JOIN INSTANT                  |  30519 |
|  6  |              NESTED JOIN (INNER JOIN)        |  147126 |
|  7  |                TABLE ACCESS ("CUSTOMER")    |  30142 |
|  8  |                  INDEX ACCESS ("ORDERS", "ORDERS_CUSTKEY_FK") |  147126 |
=====
      1 - TARGET : LINEITEM.L_ORDERKEY, ROUND(SUM( LINEITEM.L_EXTENDEDPRICE * ( 1 -
LINEITEM.L_DISCOUNT ) ),2) AS REVENUE, ORDERS.O_ORDERDATE, ORDERS.O_SHIPRIORITY
      2 - GROUP KEY : LINEITEM.L_ORDERKEY, ORDERS.O_ORDERDATE, ORDERS.O_SHIPRIORITY
          RECORD COLUMN : SUM( LINEITEM.L_EXTENDEDPRICE * ( 1 - LINEITEM.L_DISCOUNT ) )
          READ KEY COLUMN : LINEITEM.L_ORDERKEY, ORDERS.O_ORDERDATE, ORDERS.O_SHIPRIORITY
          READ RECORD COLUMN : SUM( LINEITEM.L_EXTENDEDPRICE * ( 1 - LINEITEM.L_DISCOUNT ) )
      3 - JOINED COLUMN : LINEITEM.L_ORDERKEY, ORDERS.O_ORDERDATE, ORDERS.O_SHIPRIORITY,
LINEITEM.L_EXTENDEDPRICE, LINEITEM.L_DISCOUNT
      4 - READ COLUMN : LINEITEM.L_ORDERKEY, LINEITEM.L_EXTENDEDPRICE, LINEITEM.L_DISCOUNT,
LINEITEM.L_SHIPDATE
          PHYSICAL FILTER : LINEITEM.L_SHIPDATE > DATE'1995-03-15'
      5 - HASH KEY : ORDERS.O_ORDERKEY
          RECORD COLUMN : ORDERS.O_ORDERDATE, ORDERS.O_SHIPRIORITY
          READ KEY COLUMN : ORDERS.O_ORDERKEY, ORDERS.O_ORDERDATE, ORDERS.O_SHIPRIORITY
          HASH FILTER : ORDERS.O_ORDERKEY = LINEITEM.L_ORDERKEY
      6 - JOINED COLUMN : ORDERS.O_ORDERKEY, ORDERS.O_ORDERDATE, ORDERS.O_SHIPRIORITY
      7 - READ COLUMN : CUSTOMER.C_CUSTKEY, CUSTOMER.C_MKTSEGMENT
          PHYSICAL FILTER : CUSTOMER.C_MKTSEGMENT = 'BUILDING'
      8 - READ INDEX COLUMN : ORDERS.O_CUSTKEY
          READ TABLE COLUMN : ORDERS.O_ORDERKEY, ORDERS.O_ORDERDATE, ORDERS.O_SHIPRIORITY
          MIN RANGE : ORDERS.O_CUSTKEY = {CUSTOMER.C_CUSTKEY}
          MAX RANGE : ORDERS.O_CUSTKEY = {CUSTOMER.C_CUSTKEY}

```

```

        PHYSICAL TABLE FILTER : ORDERS.O_ORDERDATE < DATE'1995-03-15'
<<< end print plan

```

In the execution plan above, join alias j10| is located on the right of the hash join.

### USE\_HASH\_OUT( alias )

If USE\_HASH\_OUT( alias ) hint is specified, then an optimizer selects hash join when determining the join operation of the join in which the alias participates. Then it places the alias on the left(outer) of the join.

If <join operation hints> already exists in the specified alias, then the hint is ignored. Also, if each different join operation hint is specified in two tables participating in join, then the hint specified in a right node(inner node) is preferentially applied.

A table name, a table alias name, a view name, a view alias name and a join alias name can be an alias.

The following is an example of using USE\_HASH\_OUT( alias ) hint.

```

\EXPLAIN PLAN
SELECT /*+ USE_HASH_OUT( orders ) */
      c_name,
      o_orderdate,
      o_orderstatus
FROM   customer,
      orders
WHERE  c_custkey = o_custkey
      AND o_orderdate >= date '1995-03-15'
      AND o_orderdate < date '1995-03-15' + interval '1' month;
>>> start print plan
< Execution Plan >
=====|  IDX  |  NODE
DESCRIPTION                               |  ROWS
|-----|-----|
|  0  | SELECT STATEMENT                          | 19343 |
|  1  |   QUERY BLOCK ("$_QB_IDX_2")              | 19343 |
|  2  |     HASH JOIN (INNER JOIN)                | 19343 |
|  3  |       TABLE ACCESS ("ORDERS")            | 19343 |
|  4  |       HASH JOIN INSTANT                   | 19343 |
|  5  |         TABLE ACCESS ("CUSTOMER")        | 150000 |
=====|-----|-----|
1 - TARGET : CUSTOMER.C_NAME, ORDERS.O_ORDERDATE, ORDERS.O_ORDERSTATUS
2 - JOINED COLUMN : CUSTOMER.C_NAME, ORDERS.O_ORDERDATE, ORDERS.O_ORDERSTATUS
3 - READ COLUMN : ORDERS.O_CUSTKEY, ORDERS.O_ORDERSTATUS, ORDERS.O_ORDERDATE
   PHYSICAL FILTER : ORDERS.O_ORDERDATE < DATE'1995-03-15' + CAST( '1' AS

```

```

INTERVAL(MONTH) ) AND ORDERS.O_ORDERDATE >= DATE '1995-03-15'
  4 - HASH KEY : CUSTOMER.C_CUSTKEY
      RECORD COLUMN : CUSTOMER.C_NAME
      READ KEY COLUMN : CUSTOMER.C_CUSTKEY, CUSTOMER.C_NAME
      HASH FILTER : CUSTOMER.C_CUSTKEY = ORDERS.O_CUSTKEY
      FETCH ONE ROW
  5 - READ COLUMN : CUSTOMER.C_CUSTKEY, CUSTOMER.C_NAME
<<< end print plan

```

### NO\_USE\_HASH( table\_name [ [ , ] table\_name ] )

If NO\_USE\_HASH( table\_name [ [ , ] table\_name ] ) hint is specified, then an optimizer excludes hash join when determining the join operation of the join in which table\_name participates. Therefore, it selects the join operation whose cost estimation is the best among other join operations except for hash join.

One or more table should be specified, and the same tables can not be specified more than two. If <join operation hints> already exists in the specified table, then the hint is ignored. Also, if each different join operation hint is specified in two tables participating in join, then the hint specified in a right node(inner node) is preferentially applied.

The following is an example of using NO\_USE\_HASH( table\_name [ [ , ] table\_name ] ) hint.

```

\EXPLAIN PLAN
SELECT /*+ NO_USE_HASH( orders ) */
      c_name,
      o_orderdate,
      o_orderstatus
FROM   customer,
      orders
WHERE  c_custkey = o_custkey
      AND o_orderdate >= date '1995-03-15'
      AND o_orderdate < date '1995-03-15' + interval '1' month;
>>> start print plan
< Execution Plan >
=====
|  IDX  |  NODE DESCRIPTION                                     |  ROWS  |
-----|-----|-----|
|  0  |  SELECT STATEMENT                                     |  19343 |
|  1  |  QUERY BLOCK ("$_QB_IDX_2")                          |  19343 |
|  2  |  NESTED JOIN (INNER JOIN)                            |  19343 |
|  3  |  TABLE ACCESS ("ORDERS")                            |  19343 |
|  4  |  INDEX ACCESS ("CUSTOMER", "CUSTOMER_PK_INDEX")     |  19343 |
=====

```

```

1 - TARGET : CUSTOMER.C_NAME, ORDERS.O_ORDERDATE, ORDERS.O_ORDERSTATUS
2 - JOINED COLUMN : CUSTOMER.C_NAME, ORDERS.O_ORDERDATE, ORDERS.O_ORDERSTATUS
3 - READ COLUMN : ORDERS.O_CUSTKEY, ORDERS.O_ORDERSTATUS, ORDERS.O_ORDERDATE
    PHYSICAL FILTER : ORDERS.O_ORDERDATE < DATE'1995-03-15' + CAST( '1' AS
INTERVAL(MONTH) ) AND ORDERS.O_ORDERDATE >= DATE'1995-03-15'
4 - READ INDEX COLUMN : CUSTOMER.C_CUSTKEY
    READ TABLE COLUMN : CUSTOMER.C_NAME
    MIN RANGE : CUSTOMER.C_CUSTKEY = {ORDERS.O_CUSTKEY}
    MAX RANGE : CUSTOMER.C_CUSTKEY = {ORDERS.O_CUSTKEY}
    FETCH ONE ROW
<<< end print plan

```

### USE\_MERGE( table\_name [ [ , ] table\_name ] )

If USE\_MERGE( table\_name [ [ , ] table\_name ] ) hint is specified, then an optimizer selects merge join when determining the join operation of the join in which table\_name participates.

One or more table should be specified, and the same tables can not be specified more than two. If <join operation hints> already exists in the specified table, then the hint is ignored. Also, if each different join operation hint is specified in two tables participating in join, then the hint specified in a right node(inner node) is preferentially applied.

The following is an example of using USE\_MERGE( table\_name [ [ , ] table\_name ] ) hint.

```

\EXPLAIN PLAN
SELECT /*+ USE_MERGE( orders ) */
    c_name,
    o_orderdate,
    o_orderstatus
FROM customer,
orders
WHERE c_custkey = o_custkey
    AND o_orderdate >= date '1995-03-15'
    AND o_orderdate < date '1995-03-15' + interval '1' month;
>>> start print plan
< Execution Plan >
=====
|  IDX  |  NODE DESCRIPTION                                     |  ROWS  |
-----|-----|-----|
|  0  |  SELECT STATEMENT                                     |  19343  |
|  1  |  QUERY BLOCK ("$_QB_IDX_2")                          |  19343  |
|  2  |  MERGE JOIN (INNER JOIN)                             |  19343  |
|  3  |  INDEX ACCESS ("CUSTOMER", "CUSTOMER_PK_INDEX")     |  150000  |

```

```

| 4 |          SORT JOIN INSTANT                      | 19343 |
| 5 |          TABLE ACCESS ("ORDERS")                | 19343 |
=====
1 - TARGET : CUSTOMER.C_NAME, ORDERS.O_ORDERDATE, ORDERS.O_ORDERSTATUS
2 - JOINED COLUMN : CUSTOMER.C_NAME, ORDERS.O_ORDERDATE, ORDERS.O_ORDERSTATUS
   ON FILTER (Equi) : CUSTOMER.C_CUSTKEY = ORDERS.O_CUSTKEY
3 - READ INDEX COLUMN : CUSTOMER.C_CUSTKEY
   READ TABLE COLUMN : CUSTOMER.C_NAME
4 - SORT KEY : "ORDERS.O_CUSTKEY ASC NULLS LAST"
   RECORD COLUMN : ORDERS.O_ORDERDATE, ORDERS.O_ORDERSTATUS
   READ KEY COLUMN : ORDERS.O_CUSTKEY
   READ RECORD COLUMN : ORDERS.O_ORDERDATE, ORDERS.O_ORDERSTATUS
   MIN RANGE : ORDERS.O_CUSTKEY >= {CUSTOMER.C_CUSTKEY}
   MAX RANGE : ORDERS.O_CUSTKEY IS NOT NULL
5 - READ COLUMN : ORDERS.O_CUSTKEY, ORDERS.O_ORDERSTATUS, ORDERS.O_ORDERDATE
   PHYSICAL FILTER : ORDERS.O_ORDERDATE < DATE'1995-03-15' + CAST( '1' AS
INTERVAL(MONTH) ) AND ORDERS.O_ORDERDATE >= DATE'1995-03-15'
<<< end print plan

```

### USE\_MERGE\_IN( alias )

If `USE_MERGE_IN( alias )` hint is specified, then an optimizer selects merge join when determining the join operation of the join in which the alias participates. Then it places the alias on the right(inner) of the join.

If `<join operation hints>` already exists in the specified alias, then the hint is ignored. Also, if each different join operation hint is specified in two tables participating in join, then the hint specified in a right node(inner node) is preferentially applied.

A table name, a table alias name, a view name, a view alias name and a join alias name can be an alias.

The following is an example of using `USE_MERGE_IN( alias )` hint.

```

\EXPLAIN PLAN
SELECT /*+ USE_MERGE_IN( orders ) */
       c_name,
       o_orderdate,
       o_orderstatus
FROM   customer,
       orders
WHERE  c_custkey = o_custkey
AND    o_orderdate >= date '1995-03-15'
AND    o_orderdate < date '1995-03-15' + interval '1' month;

```



< Execution Plan >

```

=====
|  IDX  |  NODE DESCRIPTION                                |  ROWS  |
=====
|  0  |  SELECT STATEMENT                                |  19343  |
|  1  |  QUERY BLOCK ("SQB_IDX_2")                       |  19343  |
|  2  |  MERGE JOIN (INNER JOIN)                         |  19343  |
|  3  |  INDEX ACCESS ("CUSTOMER", "CUSTOMER_PK_INDEX") | 150000  |
|  4  |  SORT JOIN INSTANT                               |  19343  |
|  5  |  TABLE ACCESS ("ORDERS")                        |  19343  |
=====

1 - TARGET : CUSTOMER.C_NAME, ORDERS.O_ORDERDATE, ORDERS.O_ORDERSTATUS
2 - JOINED COLUMN : CUSTOMER.C_NAME, ORDERS.O_ORDERDATE, ORDERS.O_ORDERSTATUS
   ON FILTER (Equi) : CUSTOMER.C_CUSTKEY = ORDERS.O_CUSTKEY
3 - READ INDEX COLUMN : CUSTOMER.C_CUSTKEY
   READ TABLE COLUMN : CUSTOMER.C_NAME
4 - SORT KEY : "ORDERS.O_CUSTKEY ASC NULLS LAST"
   RECORD COLUMN : ORDERS.O_ORDERDATE, ORDERS.O_ORDERSTATUS
   READ KEY COLUMN : ORDERS.O_CUSTKEY
   READ RECORD COLUMN : ORDERS.O_ORDERDATE, ORDERS.O_ORDERSTATUS
   MIN RANGE : ORDERS.O_CUSTKEY >= {CUSTOMER.C_CUSTKEY}
   MAX RANGE : ORDERS.O_CUSTKEY IS NOT NULL
5 - READ COLUMN : ORDERS.O_CUSTKEY, ORDERS.O_ORDERSTATUS, ORDERS.O_ORDERDATE
   PHYSICAL FILTER : ORDERS.O_ORDERDATE < DATE'1995-03-15' + CAST( '1' AS
INTERVAL(MONTH) ) AND ORDERS.O_ORDERDATE >= DATE'1995-03-15'
<<< end print plan

```

### USE\_MERGE\_OUT( alias )

If `USE_MERGE_OUT( alias )` hint is specified, then an optimizer selects merge join when determining the join operation of the join in which the alias participates. Then it places the alias on the left(outer)of the join.

If `<join operation hints>` already exists in the specified alias, then the hint is ignored. Also, if each different join operation hint is specified in two tables participating in join, then the hint specified in a right node(inner node) is preferentially applied.

The following is an example of using `USE_MERGE_OUT( alias )` hint.

```

\EXPLAIN PLAN
SELECT /*+ USE_MERGE_OUT( orders ) */
       c_name,
       o_orderdate,

```

```

        o_orderstatus
FROM customer,
    orders
WHERE c_custkey = o_custkey
      AND o_orderdate >= date '1995-03-15'
      AND o_orderdate < date '1995-03-15' + interval '1' month;

```

< Execution Plan >

```

=====
|  IDX  |  NODE DESCRIPTION                                |  ROWS  |
-----|-----|-----|
|  0  |  SELECT STATEMENT                                |  19343  |
|  1  |    QUERY BLOCK ("SQB_IDX_2")                    |  19343  |
|  2  |      MERGE JOIN (INNER JOIN)                    |  19343  |
|  3  |        SORT JOIN INSTANT                        |  19343  |
|  4  |          TABLE ACCESS ("ORDERS")                |  19343  |
|  5  |            INDEX ACCESS ("CUSTOMER", "CUSTOMER_PK_INDEX") | 149991  |
=====

1 - TARGET : CUSTOMER.C_NAME, ORDERS.O_ORDERDATE, ORDERS.O_ORDERSTATUS
2 - JOINED COLUMN : CUSTOMER.C_NAME, ORDERS.O_ORDERDATE, ORDERS.O_ORDERSTATUS
   ON FILTER (Equi) : ORDERS.O_CUSTKEY = CUSTOMER.C_CUSTKEY
3 - SORT KEY : "ORDERS.O_CUSTKEY ASC NULLS LAST"
   RECORD COLUMN : ORDERS.O_ORDERDATE, ORDERS.O_ORDERSTATUS
   READ KEY COLUMN : ORDERS.O_CUSTKEY
   READ RECORD COLUMN : ORDERS.O_ORDERDATE, ORDERS.O_ORDERSTATUS
4 - READ COLUMN : ORDERS.O_CUSTKEY, ORDERS.O_ORDERSTATUS, ORDERS.O_ORDERDATE
   PHYSICAL FILTER : ORDERS.O_ORDERDATE < DATE'1995-03-15' + CAST( '1' AS
INTERVAL(MONTH) ) AND ORDERS.O_ORDERDATE >= DATE'1995-03-15'
5 - READ INDEX COLUMN : CUSTOMER.C_CUSTKEY
   READ TABLE COLUMN : CUSTOMER.C_NAME
   MIN RANGE : CUSTOMER.C_CUSTKEY >= {ORDERS.O_CUSTKEY}
   MAX RANGE : CUSTOMER.C_CUSTKEY IS NOT NULL

```

<<< end print plan

### **NO\_USE\_MERGE( table\_name [ [ , ] table\_name ] )**

If `NO_USE_MERGE( table_name [ [ , ] table_name ] )` hint is specified, then an optimizer excludes merge join when determining the join operation of the join in which `table_name` participates. Therefore, it selects the join operation whose cost estimation is the best among other join operations except for merge join.

One or more table should be specified, and the same tables can not be specified more than two. If <join operation hints> already exists in the specified table, then the hint is ignored. Also, if each different join operation hint is specified in two tables participating in join, then the hint specified in a right node(inner n

ode) is preferentially applied.

The following is an example of using `NO_USE_MERGE( table_name [ [ , ] table_name ] )` hint.

```
\EXPLAIN PLAN
SELECT /*+ NO_USE_MERGE( orders ) */
      c_name,
      o_orderdate,
      o_orderstatus
FROM   customer,
      orders
WHERE  c_custkey = o_custkey
      AND o_orderdate >= date '1995-03-15'
      AND o_orderdate < date '1995-03-15' + interval '1' month;
< Execution Plan >
=====
|  IDX  |  NODE DESCRIPTION                                     |  ROWS  |
-----|-----|-----|
|  0  |  SELECT STATEMENT                                     |  19343  |
|  1  |    QUERY BLOCK ("SQB_IDX_2")                         |  19343  |
|  2  |      NESTED JOIN (INNER JOIN)                       |  19343  |
|  3  |        TABLE ACCESS ("ORDERS")                     |  19343  |
|  4  |          INDEX ACCESS ("CUSTOMER", "CUSTOMER_PK_INDEX") |  19343  |
=====
1 - TARGET : CUSTOMER.C_NAME, ORDERS.O_ORDERDATE, ORDERS.O_ORDERSTATUS
2 - JOINED COLUMN : CUSTOMER.C_NAME, ORDERS.O_ORDERDATE, ORDERS.O_ORDERSTATUS
3 - READ COLUMN : ORDERS.O_CUSTKEY, ORDERS.O_ORDERSTATUS, ORDERS.O_ORDERDATE
   PHYSICAL FILTER : ORDERS.O_ORDERDATE < DATE'1995-03-15' + CAST( '1' AS
INTERVAL(MONTH) ) AND ORDERS.O_ORDERDATE >= DATE'1995-03-15'
4 - READ INDEX COLUMN : CUSTOMER.C_CUSTKEY
   READ TABLE COLUMN : CUSTOMER.C_NAME
   MIN RANGE : CUSTOMER.C_CUSTKEY = {ORDERS.O_CUSTKEY}
   MAX RANGE : CUSTOMER.C_CUSTKEY = {ORDERS.O_CUSTKEY}
   FETCH ONE ROW
<<< end print plan
```

### `USE_NL( table_name [ [ , ] table_name ] )`

If `USE_NL( table_name [ [ , ] table_name ] )` hint is specified, then an optimizer selects nested loop join when determining the join operation of the join in which `table_name` participates.

One or more table should be specified, and the same tables can not be specified more than two. If `<join operation hints>` already exists in the specified table, then the hint is ignored. Also, if each different join o

operation hint is specified in two tables participating in join, then the hint specified in a right node(inner node) is preferentially applied.

The following is an example of using USE\_NL( table\_name [ [ , ] table\_name ] ) hint.

```
\EXPLAIN PLAN
  SELECT /*+ USE_NL( orders ) */
        c_name,
        o_orderdate,
        o_orderstatus
  FROM   customer,
        orders
  WHERE  c_custkey = o_custkey
        AND o_orderdate >= date '1995-03-15'
        AND o_orderdate < date '1995-03-15' + interval '1' month;
< Execution Plan >
=====
|  IDX  |  NODE DESCRIPTION                                     |  ROWS  |
-----|-----|-----|
|  0  |  SELECT STATEMENT                                     |  19343  |
|  1  |    QUERY BLOCK ("Q$QB_IDX_2")                         |  19343  |
|  2  |      NESTED JOIN (INNER JOIN)                         |  19343  |
|  3  |        TABLE ACCESS ("ORDERS")                       |  19343  |
|  4  |          INDEX ACCESS ("CUSTOMER", "CUSTOMER_PK_INDEX") |  19343  |
=====
  1 - TARGET : CUSTOMER.C_NAME, ORDERS.O_ORDERDATE, ORDERS.O_ORDERSTATUS
  2 - JOINED COLUMN : CUSTOMER.C_NAME, ORDERS.O_ORDERDATE, ORDERS.O_ORDERSTATUS
  3 - READ COLUMN : ORDERS.O_CUSTKEY, ORDERS.O_ORDERSTATUS, ORDERS.O_ORDERDATE
      PHYSICAL FILTER : ORDERS.O_ORDERDATE < DATE'1995-03-15' + CAST( '1' AS
INTERVAL(MONTH) ) AND ORDERS.O_ORDERDATE >= DATE'1995-03-15'
  4 - READ INDEX COLUMN : CUSTOMER.C_CUSTKEY
      READ TABLE COLUMN : CUSTOMER.C_NAME
      MIN RANGE : CUSTOMER.C_CUSTKEY = {ORDERS.O_CUSTKEY}
      MAX RANGE : CUSTOMER.C_CUSTKEY = {ORDERS.O_CUSTKEY}
      FETCH ONE ROW
<<< end print plan
```

### USE\_NL\_IN( alias )

If USE\_NL\_IN( alias ) hint is specified, then an optimizer selects nested loop join when determining the join operation of the join in which the alias participates. Then it places the alias on the right(inner) of the join.

A table name, a table alias name, a view name, a view alias name and a join alias name can be an alias.

The following is an example of using USE\_NL\_IN( alias ) hint.

```
\EXPLAIN PLAN
  SELECT /*+ USE_NL_IN( orders ) */
        c_name,
        o_orderdate,
        o_orderstatus
  FROM   customer,
        orders
 WHERE  c_custkey = o_custkey
        AND o_orderdate >= date '1995-03-15'
        AND o_orderdate < date '1995-03-15' + interval '1' month;
>>> start print plan
< Execution Plan >
=====
|  IDX  |  NODE DESCRIPTION                                |  ROWS  |
-----|-----|-----|
|  0  |  SELECT STATEMENT                                |  19343  |
|  1  |    QUERY BLOCK ("Q$QB_IDX_2")                    |  19343  |
|  2  |      NESTED JOIN (INNER JOIN)                    |  19343  |
|  3  |        TABLE ACCESS ("CUSTOMER")                | 150000  |
|  4  |          INDEX ACCESS ("ORDERS", "ORDERS_CUSTKEY_FK") |  19343  |
=====
  1 - TARGET : CUSTOMER.C_NAME, ORDERS.O_ORDERDATE, ORDERS.O_ORDERSTATUS
  2 - JOINED COLUMN : CUSTOMER.C_NAME, ORDERS.O_ORDERDATE, ORDERS.O_ORDERSTATUS
  3 - READ COLUMN : CUSTOMER.C_CUSTKEY, CUSTOMER.C_NAME
  4 - READ INDEX COLUMN : ORDERS.O_CUSTKEY
      READ TABLE COLUMN : ORDERS.O_ORDERSTATUS, ORDERS.O_ORDERDATE
      MIN RANGE : ORDERS.O_CUSTKEY = {CUSTOMER.C_CUSTKEY}
      MAX RANGE : ORDERS.O_CUSTKEY = {CUSTOMER.C_CUSTKEY}
      PHYSICAL TABLE FILTER : ORDERS.O_ORDERDATE < DATE'1995-03-15' + CAST( '1' AS
INTERVAL(MONTH) ) AND ORDERS.O_ORDERDATE >= DATE'1995-03-15'
<<< end print plan
```

### USE\_NL\_OUT( alias )

If USE\_NL\_OUT( alias ) hint is specified, then an optimizer selects nested loop join when determining the join operation of the join in which the alias participates. Then it places the alias on the left(outer) of the join.

A table name, a table alias name, a view name, a view alias name and a join alias name can be an alias.

The following is an example of using USE\_NL\_OUT( alias ) hint.

```

\EXPLAIN PLAN
  SELECT /*+ USE_NL_OUT( orders ) */
        c_name,
        o_orderdate,
        o_orderstatus
  FROM   customer,
        orders
 WHERE  c_custkey = o_custkey
        AND o_orderdate >= date '1995-03-15'
        AND o_orderdate < date '1995-03-15' + interval '1' month;
< Execution Plan >
=====
|  IDX  |  NODE DESCRIPTION                                     |  ROWS  |
-----|-----|-----|
|  0  |  SELECT STATEMENT                                     |  19343  |
|  1  |    QUERY BLOCK ("SQB_IDX_2")                         |  19343  |
|  2  |      NESTED JOIN (INNER JOIN)                       |  19343  |
|  3  |        TABLE ACCESS ("ORDERS")                     |  19343  |
|  4  |          INDEX ACCESS ("CUSTOMER", "CUSTOMER_PK_INDEX") |  19343  |
=====
1 - TARGET : CUSTOMER.C_NAME, ORDERS.O_ORDERDATE, ORDERS.O_ORDERSTATUS
2 - JOINED COLUMN : CUSTOMER.C_NAME, ORDERS.O_ORDERDATE, ORDERS.O_ORDERSTATUS
3 - READ COLUMN : ORDERS.O_CUSTKEY, ORDERS.O_ORDERSTATUS, ORDERS.O_ORDERDATE
   PHYSICAL FILTER : ORDERS.O_ORDERDATE < DATE'1995-03-15' + CAST( '1' AS
INTERVAL(MONTH) ) AND ORDERS.O_ORDERDATE >= DATE'1995-03-15'
4 - READ INDEX COLUMN : CUSTOMER.C_CUSTKEY
   READ TABLE COLUMN : CUSTOMER.C_NAME
   MIN RANGE : CUSTOMER.C_CUSTKEY = {ORDERS.O_CUSTKEY}
   MAX RANGE : CUSTOMER.C_CUSTKEY = {ORDERS.O_CUSTKEY}
   FETCH ONE ROW
<<< end print plan

```

### NO\_USE\_NL( table\_name [ [ , ] table\_name ] )

If NO\_USE\_NL( table\_name [ [ , ] table\_name ] ) hint is specified, then an optimizer excludes nested loop join when determining the join operation of the join in which table\_name participates. Therefore, it selects the join operation whose cost estimation is the best among other join operations except for nested loop join.

The following is an example of using NO\_USE\_NL( table\_name [ [ , ] table\_name ] ) hint.

```

\EXPLAIN PLAN
  SELECT /*+ NO_USE_NL( orders ) */
        c_name,
        o_orderdate,
        o_orderstatus
  FROM   customer,
        orders
  WHERE  c_custkey = o_custkey
        AND o_orderdate >= date '1995-03-15'
        AND o_orderdate < date '1995-03-15' + interval '1' month;
>>> start print plan
< Execution Plan >
=====
|  IDX  |  NODE DESCRIPTION                                |  ROWS  |
=====
|  0  |  SELECT STATEMENT                                |  19343 |
|  1  |    QUERY BLOCK ("SQB_IDX_2")                     |  19343 |
|  2  |      HASH JOIN (INNER JOIN)                       |  19343 |
|  3  |        TABLE ACCESS ("CUSTOMER")                 | 150000 |
|  4  |          HASH JOIN INSTANT                         |  19343 |
|  5  |            TABLE ACCESS ("ORDERS")                |  19343 |
=====
  1 - TARGET : CUSTOMER.C_NAME, ORDERS.O_ORDERDATE, ORDERS.O_ORDERSTATUS
  2 - JOINED COLUMN : CUSTOMER.C_NAME, ORDERS.O_ORDERDATE, ORDERS.O_ORDERSTATUS
  3 - READ COLUMN : CUSTOMER.C_CUSTKEY, CUSTOMER.C_NAME
  4 - HASH KEY : ORDERS.O_CUSTKEY
      RECORD COLUMN : ORDERS.O_ORDERDATE, ORDERS.O_ORDERSTATUS
      READ KEY COLUMN : ORDERS.O_CUSTKEY, ORDERS.O_ORDERDATE, ORDERS.O_ORDERSTATUS
      HASH FILTER : ORDERS.O_CUSTKEY = CUSTOMER.C_CUSTKEY
  5 - READ COLUMN : ORDERS.O_CUSTKEY, ORDERS.O_ORDERSTATUS, ORDERS.O_ORDERDATE
      PHYSICAL FILTER : ORDERS.O_ORDERDATE < DATE'1995-03-15' + CAST( '1' AS
INTERVAL(MONTH) ) AND ORDERS.O_ORDERDATE >= DATE'1995-03-15'
<<< end print plan

```

### USE\_INL( table\_name [ [ , ] table\_name ] )

If USE\_INL( table\_name [ [ , ] table\_name ] ) hint is specified, then an optimizer selects instant nested loop join when determining the join operation of the join in which table\_name participates.

One or more table should be specified, and the same tables can not be specified more than two. If <join operation hints> already exists in the specified table, then the hint is ignored. Also, if each different join operation hint is specified in two tables participating in join, then the hint specified in a right node(inner n

ode) is preferentially applied.

The following is an example of using USE\_INL( table\_name [ [ , ] table\_name ] ) hint.

```

\EXPLAIN PLAN
  SELECT /*+ USE_INL( orders ) */
        c_name,
        o_orderdate,
        o_orderstatus
  FROM   customer,
        orders
 WHERE  c_custkey = o_custkey
        AND o_orderdate >= date '1995-03-15'
        AND o_orderdate < date '1995-03-15' + interval '1' month;
>>> start print plan
< Execution Plan >
=====
|  IDX  |  NODE DESCRIPTION                               |  ROWS  |
-----|-----|-----|
|  0  |  SELECT STATEMENT                               |  19343  |
|  1  |    QUERY BLOCK ("Q$QB_IDX_2")                   |  19343  |
|  2  |      NESTED JOIN (INNER JOIN)                   |  19343  |
|  3  |        TABLE ACCESS ("ORDERS")                 |  19343  |
|  4  |          SORT JOIN INSTANT                       |  19343  |
|  5  |            TABLE ACCESS ("CUSTOMER")           | 150000  |
=====
1 - TARGET : CUSTOMER.C_NAME, ORDERS.O_ORDERDATE, ORDERS.O_ORDERSTATUS
2 - JOINED COLUMN : CUSTOMER.C_NAME, ORDERS.O_ORDERDATE, ORDERS.O_ORDERSTATUS
3 - READ COLUMN : ORDERS.O_CUSTKEY, ORDERS.O_ORDERSTATUS, ORDERS.O_ORDERDATE
   PHYSICAL FILTER : ORDERS.O_ORDERDATE < DATE'1995-03-15' + CAST( '1' AS
INTERVAL(MONTH) ) AND ORDERS.O_ORDERDATE >= DATE'1995-03-15'
4 - SORT KEY : "CUSTOMER.C_CUSTKEY ASC NULLS LAST"
   RECORD COLUMN : CUSTOMER.C_NAME
   READ KEY COLUMN : CUSTOMER.C_CUSTKEY
   READ RECORD COLUMN : CUSTOMER.C_NAME
   MIN RANGE : CUSTOMER.C_CUSTKEY = {ORDERS.O_CUSTKEY}
   MAX RANGE : CUSTOMER.C_CUSTKEY = {ORDERS.O_CUSTKEY}
5 - READ COLUMN : CUSTOMER.C_CUSTKEY, CUSTOMER.C_NAME
<<< end print plan

```



**USE\_INL\_IN( alias )**

If USE\_INL\_IN( alias ) hint is specified, then an optimizer selects instant nested loop join when determining the join operation of the join in which the alias participates. Then it places the alias on the right(inner) of the join.

A table name, a table alias name, a view name, a view alias name and a join alias name can be an alias.

The following is an example of using USE\_INL\_IN( alias ) hint.

```
\EXPLAIN PLAN
SELECT /*+ USE_INL_IN( orders ) */
      c_name,
      o_orderdate,
      o_orderstatus
FROM   customer,
      orders
WHERE  c_custkey = o_custkey
      AND o_orderdate >= date '1995-03-15'
      AND o_orderdate < date '1995-03-15' + interval '1' month;
>>> start print plan
< Execution Plan >
```

IDX	NODE DESCRIPTION	ROWS
0	SELECT STATEMENT	19343
1	QUERY BLOCK ("SQB_IDX_2")	19343
2	NESTED JOIN (INNER JOIN)	19343
3	TABLE ACCESS ("CUSTOMER")	150000
4	SORT JOIN INSTANT	19343
5	TABLE ACCESS ("ORDERS")	19343

```

1 - TARGET : CUSTOMER.C_NAME, ORDERS.O_ORDERDATE, ORDERS.O_ORDERSTATUS
2 - JOINED COLUMN : CUSTOMER.C_NAME, ORDERS.O_ORDERDATE, ORDERS.O_ORDERSTATUS
3 - READ COLUMN : CUSTOMER.C_CUSTKEY, CUSTOMER.C_NAME
4 - SORT KEY : "ORDERS.O_CUSTKEY ASC NULLS LAST"
   RECORD COLUMN : ORDERS.O_ORDERDATE, ORDERS.O_ORDERSTATUS
   READ KEY COLUMN : ORDERS.O_CUSTKEY
   READ RECORD COLUMN : ORDERS.O_ORDERDATE, ORDERS.O_ORDERSTATUS
   MIN RANGE : ORDERS.O_CUSTKEY = {CUSTOMER.C_CUSTKEY}
   MAX RANGE : ORDERS.O_CUSTKEY = {CUSTOMER.C_CUSTKEY}
5 - READ COLUMN : ORDERS.O_CUSTKEY, ORDERS.O_ORDERSTATUS, ORDERS.O_ORDERDATE
   PHYSICAL FILTER : ORDERS.O_ORDERDATE < DATE'1995-03-15' + CAST( '1' AS
```

```
INTERVAL(MONTH) ) AND ORDERS.O_ORDERDATE >= DATE '1995-03-15'
<<< end print plan
```

### USE\_INL\_OUT( alias )

If USE\_INL\_OUT( alias ) hint is specified, then an optimizer selects instant nested loop join when determining the join operation of the join in which the alias participates. Then it places the alias on the left(outer) of the join.

A table name, a table alias name, a view name, a view alias name and a join alias name can be an alias.

The following is an example of using USE\_INL\_OUT( alias ) hint.

```
\EXPLAIN PLAN
SELECT /*+ USE_INL_OUT( orders ) */
      c_name,
      o_orderdate,
      o_orderstatus
FROM   customer,
      orders
WHERE  c_custkey = o_custkey
      AND o_orderdate >= date '1995-03-15'
      AND o_orderdate < date '1995-03-15' + interval '1' month;
>>> start print plan
< Execution Plan >
=====
|  IDX  |  NODE DESCRIPTION                                |  ROWS  |
-----|-----|-----|
|  0  |  SELECT STATEMENT                                |  19343  |
|  1  |    QUERY BLOCK ("QB_IDX_2")                      |  19343  |
|  2  |      NESTED JOIN (INNER JOIN)                    |  19343  |
|  3  |        TABLE ACCESS ("ORDERS")                  |  19343  |
|  4  |          SORT JOIN INSTANT                       |  19343  |
|  5  |            TABLE ACCESS ("CUSTOMER")            | 150000  |
=====
1 - TARGET : CUSTOMER.C_NAME, ORDERS.O_ORDERDATE, ORDERS.O_ORDERSTATUS
2 - JOINED COLUMN : CUSTOMER.C_NAME, ORDERS.O_ORDERDATE, ORDERS.O_ORDERSTATUS
3 - READ COLUMN : ORDERS.O_CUSTKEY, ORDERS.O_ORDERSTATUS, ORDERS.O_ORDERDATE
   PHYSICAL FILTER : ORDERS.O_ORDERDATE < DATE '1995-03-15' + CAST( '1' AS
INTERVAL(MONTH) ) AND ORDERS.O_ORDERDATE >= DATE '1995-03-15'
4 - SORT KEY : "CUSTOMER.C_CUSTKEY ASC NULLS LAST"
   RECORD COLUMN : CUSTOMER.C_NAME
   READ KEY COLUMN : CUSTOMER.C_CUSTKEY
```

```

        READ RECORD COLUMN : CUSTOMER.C_NAME
        MIN RANGE : CUSTOMER.C_CUSTKEY = {ORDERS.O_CUSTKEY}
        MAX RANGE : CUSTOMER.C_CUSTKEY = {ORDERS.O_CUSTKEY}
5 - READ COLUMN : CUSTOMER.C_CUSTKEY, CUSTOMER.C_NAME
<<< end print plan

```

### NO\_USE\_INL( table\_name [ [ , ] table\_name ] )

If NO\_USE\_INL( table\_name [ [ , ] table\_name ] ) hint is specified, then an optimizer excludes instant nested loop join when determining the join operation of the join in which table\_name participates. Therefore, it selects the join operation whose cost estimation is the best among other join operations except for instant nested loop join.

One or more table should be specified, and the same tables can not be specified more than two. If <join operation hints> already exists in the specified table, then the hint is ignored. Also, if each different join operation hint is specified in two tables participating in join, then the hint specified in a right node(inner node) is preferentially applied.

The following is an example of using NO\_USE\_INL( table\_name [ [ , ] table\_name ] ) hint.

```

\EXPLAIN PLAN
SELECT /*+ NO_USE_INL( orders ) */
    c_name,
    o_orderdate,
    o_orderstatus
FROM customer,
    orders
WHERE c_custkey = o_custkey
    AND o_orderdate >= date '1995-03-15'
    AND o_orderdate < date '1995-03-15' + interval '1' month;
< Execution Plan >
=====
|  IDX  |  NODE DESCRIPTION                                     |  ROWS  |
-----|-----|-----|
|  0  |  SELECT STATEMENT                                     |  19343  |
|  1  |    QUERY BLOCK ("$_QB_IDX_2")                         |  19343  |
|  2  |      NESTED JOIN (INNER JOIN)                         |  19343  |
|  3  |        TABLE ACCESS ("ORDERS")                       |  19343  |
|  4  |          INDEX ACCESS ("CUSTOMER", "CUSTOMER_PK_INDEX") |  19343  |
=====
1 - TARGET : CUSTOMER.C_NAME, ORDERS.O_ORDERDATE, ORDERS.O_ORDERSTATUS
2 - JOINED COLUMN : CUSTOMER.C_NAME, ORDERS.O_ORDERDATE, ORDERS.O_ORDERSTATUS
3 - READ COLUMN : ORDERS.O_CUSTKEY, ORDERS.O_ORDERSTATUS, ORDERS.O_ORDERDATE

```

```

          PHYSICAL FILTER : ORDERS.O_ORDERDATE < DATE'1995-03-15' + CAST( '1' AS
INTERVAL(MONTH) ) AND ORDERS.O_ORDERDATE >= DATE'1995-03-15'
    4 - READ INDEX COLUMN : CUSTOMER.C_CUSTKEY
          READ TABLE COLUMN : CUSTOMER.C_NAME
          MIN RANGE : CUSTOMER.C_CUSTKEY = {ORDERS.O_CUSTKEY}
          MAX RANGE : CUSTOMER.C_CUSTKEY = {ORDERS.O_CUSTKEY}
          FETCH ONE ROW
<<< end print plan

```

### USE\_JOIN\_COMBINE( alias )

If USE\_JOIN\_COMBINE( alias ) hint is specified, then an optimizer selects join combine when determining the join operation of the join in which the alias participates.

A table name, a table alias name, a view name, a view alias name and a join alias name can be an alias.

The following is an example of using USE\_JOIN\_COMBINE( alias ) hint.

```

\EXPLAIN PLAN
SELECT /*+ USE_JOIN_COMBINE(part) */
      sum(l_extendedprice * (1 - l_discount) ) as revenue
FROM lineitem,
      part
WHERE
  (
    p_partkey = l_partkey
  and p_brand = 'Brand#12'
  and p_container in ( 'SM CASE', 'SM BOX', 'SM PACK', 'SM PKG' )
  and l_quantity >= 1 and l_quantity <= 1 + 10
  and p_size between 1 and 5
  and l_shipmode in ( 'AIR', 'AIR REG' )
  and l_shipinstruct = 'DELIVER IN PERSON'
  )
or
  (
    p_partkey = l_partkey
  and p_brand = 'Brand#23'
  and p_container in ( 'MED BAG', 'MED BOX', 'MED PKG', 'MED PACK' )
  and l_quantity >= 10 and l_quantity <= 10 + 10
  and p_size between 1 and 10
  and l_shipmode in ( 'AIR', 'AIR REG' )
  and l_shipinstruct = 'DELIVER IN PERSON'
  )

```

```

or
(
    p_partkey = l_partkey
and p_brand = 'Brand#34'
and p_container in ( 'LG CASE', 'LG BOX', 'LG PACK', 'LG PKG' )
and l_quantity >= 20 and l_quantity <= 20 + 10
and p_size between 1 and 15
and l_shipmode in ( 'AIR', 'AIR REG' )
and l_shipinstruct = 'DELIVER IN PERSON'
);

```

```
>>> start print plan
```

```
< Execution Plan >
```

```

=====
|IDX|  NODE DESCRIPTION                                     |
-----
| 0 |  SELECT STATEMENT                                       |
| 1 |    QUERY BLOCK ("$_QB_IDX_2")                          |
| 2 |      AGGREGATION BY HASH                               |
| 3 |        CONCAT (Compare Nothing)                       |
| 4 |          NESTED JOIN (INNER JOIN)                     |
| 5 |            TABLE ACCESS ("PART")                     |
| 6 |              INDEX ACCESS ("LINEITEM", "LINEITEM_PARTKEY_SUPPKEY_FK") |
| 7 |                NESTED JOIN (INNER JOIN)               |
| 8 |                  TABLE ACCESS ("PART")               |
| 9 |                    INDEX ACCESS ("LINEITEM", "LINEITEM_PARTKEY_SUPPKEY_FK") |
|10 |                      NESTED JOIN (INNER JOIN)         |
|11 |                        TABLE ACCESS ("PART")         |
|12 |                          INDEX ACCESS ("LINEITEM", "LINEITEM_PARTKEY_SUPPKEY_FK") |
=====

 1 - TARGET : SUM( LINEITEM.L_EXTENDEDPRI * ( 1 - LINEITEM.L_DISCOUNT ) ) AS REVENUE
 2 - AGGREGATION : SUM( LINEITEM.L_EXTENDEDPRI * ( 1 - LINEITEM.L_DISCOUNT ) )
 3 - CONCAT COLUMN : LINEITEM.L_EXTENDEDPRI, LINEITEM.L_DISCOUNT
 4 - JOINED COLUMN : LINEITEM.L_EXTENDEDPRI, LINEITEM.L_DISCOUNT
 5 - READ COLUMN : PART.P_PARTKEY, PART.P_BRAND, PART.P_SIZE, PART.P_CONTAINER
      PHYSICAL FILTER : PART.P_BRAND = 'Brand#12' AND PART.P_SIZE <= 5 AND PART.P_SIZE
>= 1 AND ( PART.P_CONTAINER ) IN ( 'SM CASE', 'SM BOX', 'SM PACK', 'SM PKG' )
 6 - READ INDEX COLUMN : LINEITEM.L_PARTKEY
      READ TABLE COLUMN : LINEITEM.L_QUANTITY, LINEITEM.L_EXTENDEDPRI,
LINEITEM.L_DISCOUNT, LINEITEM.L_SHIPINSTRUCT, LINEITEM.L_SHIPMODE
      MIN RANGE : LINEITEM.L_PARTKEY = {PART.P_PARTKEY}
      MAX RANGE : LINEITEM.L_PARTKEY = {PART.P_PARTKEY}

```

```

        PHYSICAL TABLE FILTER : LINEITEM.L_QUANTITY <= 1 + 10 AND LINEITEM.L_QUANTITY >=
1 AND LINEITEM.L_SHIPINSTRUCT = 'DELIVER IN PERSON' AND ( LINEITEM.L_SHIPMODE ) IN ( 'AIR',
'AIR REG' )
    7 - JOINED COLUMN : LINEITEM.L_EXTENDEDPRI, LINEITEM.L_DISCOUNT
    8 - READ COLUMN : PART.P_PARTKEY, PART.P_BRAND, PART.P_SIZE, PART.P_CONTAINER
        PHYSICAL FILTER : PART.P_BRAND = 'Brand#23' AND PART.P_SIZE <= 10 AND PART.P_SIZE
>= 1 AND ( PART.P_CONTAINER ) IN ( 'MED BAG', 'MED BOX', 'MED PKG', 'MED PACK' )
    9 - READ INDEX COLUMN : LINEITEM.L_PARTKEY
        READ TABLE COLUMN : LINEITEM.L_QUANTITY, LINEITEM.L_EXTENDEDPRI,
LINEITEM.L_DISCOUNT, LINEITEM.L_SHIPINSTRUCT, LINEITEM.L_SHIPMODE
        MIN RANGE : LINEITEM.L_PARTKEY = {PART.P_PARTKEY}
        MAX RANGE : LINEITEM.L_PARTKEY = {PART.P_PARTKEY}
        PHYSICAL TABLE FILTER : LINEITEM.L_QUANTITY <= 10 + 10 AND LINEITEM.L_QUANTITY >=
10 AND LINEITEM.L_SHIPINSTRUCT = 'DELIVER IN PERSON' AND ( LINEITEM.L_SHIPMODE ) IN ( 'AIR',
'AIR REG' )
    10 - JOINED COLUMN : LINEITEM.L_EXTENDEDPRI, LINEITEM.L_DISCOUNT
    11 - READ COLUMN : PART.P_PARTKEY, PART.P_BRAND, PART.P_SIZE, PART.P_CONTAINER
        PHYSICAL FILTER : PART.P_BRAND = 'Brand#34' AND PART.P_SIZE <= 15 AND PART.P_SIZE
>= 1 AND ( PART.P_CONTAINER ) IN ( 'LG CASE', 'LG BOX', 'LG PACK', 'LG PKG' )
    12 - READ INDEX COLUMN : LINEITEM.L_PARTKEY
        READ TABLE COLUMN : LINEITEM.L_QUANTITY, LINEITEM.L_EXTENDEDPRI,
LINEITEM.L_DISCOUNT, LINEITEM.L_SHIPINSTRUCT, LINEITEM.L_SHIPMODE
        MIN RANGE : LINEITEM.L_PARTKEY = {PART.P_PARTKEY}
        MAX RANGE : LINEITEM.L_PARTKEY = {PART.P_PARTKEY}
        PHYSICAL TABLE FILTER : LINEITEM.L_QUANTITY <= 20 + 10 AND LINEITEM.L_QUANTITY >=
20 AND LINEITEM.L_SHIPINSTRUCT = 'DELIVER IN PERSON' AND ( LINEITEM.L_SHIPMODE ) IN ( 'AIR',
'AIR REG' )
<<< end print plan

```

### NO\_USE\_JOIN\_COMBINE( alias )

If NO\_USE\_JOIN\_COMBINE( alias ) hint is specified, then an optimizer excludes join combine when determining the join operation of the join in which the alias participates.

A table name, a table alias name, a view name, a view alias name and a join alias name can be an alias.

The following is an example of using NO\_USE\_JOIN\_COMBINE( alias ) hint.

```

\EXPLAIN PLAN
SELECT /*+ NO_USE_JOIN_COMBINE(part) */
    sum(l_extendedprice * (1 - l_discount) ) as revenue
FROM lineitem,
    part

```

```

WHERE
  (
    p_partkey = l_partkey
  and p_brand = 'Brand#12'
  and p_container in ( 'SM CASE', 'SM BOX', 'SM PACK', 'SM PKG')
  and l_quantity >= 1 and l_quantity <= 1 + 10
  and p_size between 1 and 5
  and l_shipmode in ('AIR', 'AIR REG')
  and l_shipinstruct = 'DELIVER IN PERSON'
  )
or
  (
    p_partkey = l_partkey
  and p_brand = 'Brand#23'
  and p_container in ('MED BAG', 'MED BOX', 'MED PKG', 'MED PACK')
  and l_quantity >= 10 and l_quantity <= 10 + 10
  and p_size between 1 and 10
  and l_shipmode in ('AIR', 'AIR REG')
  and l_shipinstruct = 'DELIVER IN PERSON'
  )
or
  (
    p_partkey = l_partkey
  and p_brand = 'Brand#34'
  and p_container in ( 'LG CASE', 'LG BOX', 'LG PACK', 'LG PKG')
  and l_quantity >= 20 and l_quantity <= 20 + 10
  and p_size between 1 and 15
  and l_shipmode in ('AIR', 'AIR REG')
  and l_shipinstruct = 'DELIVER IN PERSON'
  )
);

```

```
>>> start print plan
```

```
< Execution Plan >
```

```

=====
|IDX|  NODE DESCRIPTION                                     |
-----|-----|
| 0 |  SELECT STATEMENT                                       |
| 1 |    QUERY BLOCK ("QB_IDX_2")                             |
| 2 |      AGGREGATION BY HASH                               |
| 3 |        NESTED JOIN (INNER JOIN)                       |
| 4 |          TABLE ACCESS ("PART")                       |
| 5 |            CONCAT (Compare Nothing)                   |

```

```

| 6 |          INDEX ACCESS ("LINEITEM", "LINEITEM_PARTKEY_SUPPKEY_FK") |
| 7 |          INDEX ACCESS ("LINEITEM", "LINEITEM_PARTKEY_SUPPKEY_FK") |
| 8 |          INDEX ACCESS ("LINEITEM", "LINEITEM_PARTKEY_SUPPKEY_FK") |
=====
1 - TARGET : SUM( LINEITEM.L_EXTENDEDPRI * ( 1 - LINEITEM.L_DISCOUNT ) ) AS REVENUE
2 - AGGREGATION : SUM( LINEITEM.L_EXTENDEDPRI * ( 1 - LINEITEM.L_DISCOUNT ) )
3 - JOINED COLUMN : LINEITEM.L_EXTENDEDPRI, LINEITEM.L_DISCOUNT
4 - READ COLUMN : PART.P_PARTKEY, PART.P_BRAND, PART.P_SIZE, PART.P_CONTAINER
5 - CONCAT COLUMN : LINEITEM.L_EXTENDEDPRI, LINEITEM.L_DISCOUNT
6 - READ INDEX COLUMN : LINEITEM.L_PARTKEY
   READ TABLE COLUMN : LINEITEM.L_QUANTITY, LINEITEM.L_EXTENDEDPRI,
LINEITEM.L_DISCOUNT, LINEITEM.L_SHIPINSTRUCT, LINEITEM.L_SHIPMODE
   MIN RANGE : LINEITEM.L_PARTKEY = {PART.P_PARTKEY}
   MAX RANGE : LINEITEM.L_PARTKEY = {PART.P_PARTKEY}
   PHYSICAL TABLE FILTER : LINEITEM.L_QUANTITY <= 1 + 10 AND LINEITEM.L_QUANTITY >=
1 AND LINEITEM.L_SHIPINSTRUCT = 'DELIVER IN PERSON' AND ( LINEITEM.L_SHIPMODE ) IN ( 'AIR',
'AIR REG' )
   CONSTANT FILTER : {PART.P_BRAND} = 'Brand#12' AND ( {PART.P_CONTAINER} ) IN ( 'SM
CASE', 'SM BOX', 'SM PACK', 'SM PKG' ) AND {PART.P_SIZE} <= 5 AND {PART.P_SIZE} >= 1
7 - READ INDEX COLUMN : LINEITEM.L_PARTKEY
   READ TABLE COLUMN : LINEITEM.L_QUANTITY, LINEITEM.L_EXTENDEDPRI,
LINEITEM.L_DISCOUNT, LINEITEM.L_SHIPINSTRUCT, LINEITEM.L_SHIPMODE
   MIN RANGE : LINEITEM.L_PARTKEY = {PART.P_PARTKEY}
   MAX RANGE : LINEITEM.L_PARTKEY = {PART.P_PARTKEY}
   PHYSICAL TABLE FILTER : LINEITEM.L_QUANTITY <= 10 + 10 AND LINEITEM.L_QUANTITY >=
10 AND LINEITEM.L_SHIPINSTRUCT = 'DELIVER IN PERSON' AND ( LINEITEM.L_SHIPMODE ) IN ( 'AIR',
'AIR REG' )
   CONSTANT FILTER : {PART.P_BRAND} = 'Brand#23' AND ( {PART.P_CONTAINER} ) IN (
'MED BAG', 'MED BOX', 'MED PKG', 'MED PACK' ) AND {PART.P_SIZE} <= 10 AND {PART.P_SIZE} >= 1
8 - READ INDEX COLUMN : LINEITEM.L_PARTKEY
   READ TABLE COLUMN : LINEITEM.L_QUANTITY, LINEITEM.L_EXTENDEDPRI,
LINEITEM.L_DISCOUNT, LINEITEM.L_SHIPINSTRUCT, LINEITEM.L_SHIPMODE
   MIN RANGE : LINEITEM.L_PARTKEY = {PART.P_PARTKEY}
   MAX RANGE : LINEITEM.L_PARTKEY = {PART.P_PARTKEY}
   PHYSICAL TABLE FILTER : LINEITEM.L_QUANTITY <= 20 + 10 AND LINEITEM.L_QUANTITY >=
20 AND LINEITEM.L_SHIPINSTRUCT = 'DELIVER IN PERSON' AND ( LINEITEM.L_SHIPMODE ) IN ( 'AIR',
'AIR REG' )
   CONSTANT FILTER : {PART.P_BRAND} = 'Brand#34' AND ( {PART.P_CONTAINER} ) IN ( 'LG
CASE', 'LG BOX', 'LG PACK', 'LG PKG' ) AND {PART.P_SIZE} <= 15 AND {PART.P_SIZE} >= 1
<<< end print plan

```



## <join driver hints>

Those hints are available when performing the join in the cluster system. They are ignored in the standalone system.

### LOCAL\_JOIN( alias )

It performs the join in the current server when an alias participates in the join. If both a left child and a right child are sharded tables, it brings all subordinate rows to a local, then performs the join.

The following is an example of using LOCAL\_JOIN hint.

```
\EXPLAIN PLAN
SELECT /*+ LOCAL_JOIN(lineitem) */
      l_orderkey, p_partkey
FROM part, lineitem
WHERE p_partkey = l_partkey;
>>> start print plan
< Execution Plan >
=====
|  IDX  |  NODE DESCRIPTION                               |  ROWS  |
=====
|  0  |  SELECT STATEMENT                               |        |
|  1  |    QUERY BLOCK ("$_QB_IDX_2")                   |        |
|  2  |      HASH JOIN (INNER JOIN)                     |        |
|  3  |        PLAN BASED CLUSTER                       | LOCAL/REMOTE 200000 |
|  4  |          INDEX ACCESS ("PART", "PART_PK_INDEX") | (66675) 66675 |
|  5  |            HASH JOIN INSTANT                     |        |
|  6  |              PLAN BASED CLUSTER                 | LOCAL/REMOTE 2528 |
|  7  |                TABLE ACCESS ("LINEITEM")      |        |
=====

1 - TARGET : LINEITEM.L_ORDERKEY, PART.P_PARTKEY
2 - JOINED COLUMN : LINEITEM.L_ORDERKEY, PART.P_PARTKEY
3 - SQL : SELECT /*+ INDEX( _A1, "PUBLIC"."PART_PK_INDEX" ) */
      "_A1"."P_PARTKEY"
      FROM "PUBLIC"."PART"@LOCAL AS "_A1"
      TARGET DOMAIN : G1(G1N1,G1N2) 66675 rows,
                      G2(G2N1,G2N2) 66664 rows,
                      G3(G3N1,G3N2) 66661 rows
4 - HASH SHARD ( # 3 )
      READ INDEX COLUMN : PART.P_PARTKEY
5 - HASH KEY : LINEITEM.L_PARTKEY
      RECORD COLUMN : LINEITEM.L_ORDERKEY
```

```

        READ KEY COLUMN : LINEITEM.L_PARTKEY, LINEITEM.L_ORDERKEY
        HASH FILTER : LINEITEM.L_PARTKEY = PART.P_PARTKEY
6 - SQL : SELECT /** FULL( _A1 ) */
        "_A1"."L_ORDERKEY", "_A1"."L_PARTKEY"
        FROM "PUBLIC"."LINEITEM"@LOCAL AS "_A1"
        WHERE "_A1"."L_SHIPDATE" = :_V0
        TARGET DOMAIN : G1(G1N1,G1N2) 840 rows,
        G2(G2N1,G2N2) 824 rows,
        G3(G3N1,G3N2) 864 rows
7 - HASH SHARD ( # 3 )
        READ COLUMN : LINEITEM.L_ORDERKEY, LINEITEM.L_PARTKEY, LINEITEM.L_SHIPDATE
        PHYSICAL FILTER : LINEITEM.L_SHIPDATE = DATE'1995-03-15'
<<< end print plan

```

Both part and lineitem are hash sharded tables. In the execution plan above, it brings both tables to G1, G2 and G3, then performs the join in a local.

### REMOTE\_JOIN( alias )

It performs the join in each server when an alias participates in the join.

The following is an example of using REMOTE\_JOIN hint.

```

\EXPLAIN PLAN
SELECT /** REMOTE_JOIN(lineitem) */
    l_orderkey, p_partkey
FROM part, lineitem
WHERE p_partkey = l_partkey
    AND l_shipdate = date '1995-03-15';
>>> start print plan
< Execution Plan >
=====
|  IDX  |NODE DESCRIPTION                                     |      ROWS |
-----|-----|-----|
|  0  |SELECT STATEMENT                                     |      2528 |
|  1  |  QUERY BLOCK ("$_QB_IDX_2")                         |      2528 |
|  2  |    SINGLE CLUSTER                                   | LOCAL/REMOTE 2528 |
|  3  |      CLUSTER PUSHER ("$_$NI_5")                     |      2528 |
|  4  |        PLAN BASED CLUSTER                           | LOCAL/REMOTE 2528 |
|  5  |          TABLE ACCESS ("LINEITEM")                 |        840 |
|  6  |    SELECT STATEMENT                                 |        857 |
|  7  |      QUERY BLOCK ("$_QB_IDX_2")                     |        857 |
|  8  |        NESTED JOIN (INNER JOIN)                     |        857 |

```

```
| 9 |          PUSHER TABLE ACCESS ("$_NI_5" AS _A2)          |      857 |
| 10 |          INDEX ACCESS ("PART" AS _A1, "PART_PK_INDEX") | (857) 857 |
```

```
=====
1 - TARGET : $_NI_5.L_ORDERKEY, PART.P_PARTKEY
2 - SQL : SELECT /*+ KEEP_JOINED_TABLE
          USE_NL_IN( _A1 )
          FULL( _A2 )
          INDEX( _A1, "PUBLIC"."PART_PK_INDEX" )
          */
          "_A2"."L_ORDERKEY", "_A1"."P_PARTKEY"
FROM ( "SESSION_SCHEMA"."$_NI_5"@LOCAL AS "_A2"
      INNER JOIN
      "PUBLIC"."PART"@LOCAL AS "_A1"
      ON true
      ) ALIAS "_A3"
WHERE "_A1"."P_PARTKEY" = "_A2"."L_PARTKEY"
TARGET DOMAIN : G1(G1N1,G1N2) 857 rows,
                G2(G2N1,G2N2) 845 rows,
                G3(G3N1,G3N2) 826 rows
3 - SQL : DECLARE INSTANT TABLE "SESSION_SCHEMA"."$_NI_5"
      ( "L_PARTKEY" NUMBER(10, 0), "L_ORDERKEY" NUMBER(10, 0) )
COLUMN : LINEITEM.L_PARTKEY AS L_PARTKEY, LINEITEM.L_ORDERKEY AS L_ORDERKEY
SHARDED : LINEITEM.L_PARTKEY
TARGET DOMAIN : G1(G1N1,G1N2) 857 rows,
                G2(G2N1,G2N2) 845 rows,
                G3(G3N1,G3N2) 826 rows
4 - SQL : SELECT /*+ FULL( _A1 ) */
          "_A1"."L_ORDERKEY", "_A1"."L_PARTKEY"
FROM "PUBLIC"."LINEITEM"@LOCAL AS "_A1"
WHERE "_A1"."L_SHIPDATE" = :_V0
TARGET DOMAIN : G1(G1N1,G1N2) 840 rows,
                G2(G2N1,G2N2) 824 rows,
                G3(G3N1,G3N2) 864 rows
5 - HASH SHARD ( # 3 )
READ COLUMN : LINEITEM.L_ORDERKEY, LINEITEM.L_PARTKEY, LINEITEM.L_SHIPDATE
PHYSICAL FILTER : LINEITEM.L_SHIPDATE = DATE'1995-03-15'
7 - TARGET : _A2.L_ORDERKEY, _A1.P_PARTKEY
8 - JOINED COLUMN : _A2.L_ORDERKEY, _A1.P_PARTKEY
CONSTANT FILTER : TRUE
9 - READ COLUMN : _A2.L_PARTKEY, _A2.L_ORDERKEY
10 - HASH SHARD ( # 3 )
```

```

      READ INDEX COLUMN : _A1.P_PARTKEY
      MIN RANGE : _A1.P_PARTKEY = {_A2.L_PARTKEY}
      MAX RANGE : _A1.P_PARTKEY = {_A2.L_PARTKEY}
      FETCH ONE ROW
<<< end print plan

```

In the execution plan above, it performs the remote join by creating lineitem as a pusher table whose shard key is l\_partkey, then transferring SQL to each server.

## <join pusher hints>

Those hints are used when performing the remote join in a cluster system. It is ignored in a standalone system.

### PUSHER( alias )

It builds a table or a view corresponding to an alias as a pusher table when an alias participates in a remote join.

The hint is not applied when the remote join is available without a pusher table.

The following is an example of using PUSHER hint.

```

\EXPLAIN PLAN
SELECT /*+ PUSHER(lineitem) */
      l_orderkey, p_partkey
FROM part, lineitem
WHERE p_partkey = l_partkey
      AND l_shipdate = date '1995-03-15';
>>> start print plan
< Execution Plan >
=====
|  IDX  |  NODE DESCRIPTION                                     |  ROWS  |
-----|-----|-----|
|  0  |  SELECT STATEMENT                                     |  2528  |
|  1  |    QUERY BLOCK ("$_QB_IDX_2")                         |  2528  |
|  2  |      SINGLE CLUSTER                                  | LOCAL/REMOTE 2528 |
|  3  |        CLUSTER PUSHER ("$_NI_5")                     |  2528  |
|  4  |          PLAN BASED CLUSTER                           | LOCAL/REMOTE 2528 |
|  5  |            TABLE ACCESS ("LINEITEM")                 |  840  |
|  6  |      SELECT STATEMENT                                 |  857  |
|  7  |        QUERY BLOCK ("$_QB_IDX_2")                     |  857  |
|  8  |          NESTED JOIN (INNER JOIN)                     |  857  |
|  9  |            PUSHER TABLE ACCESS ("$_NI_5" AS _A2)     |  857  |

```

```

| 10 |                INDEX ACCESS ("PART" AS _A1, "PART_PK_INDEX")                | 857 |
=====
1 - TARGET : _$NI_5.L_ORDERKEY, PART.P_PARTKEY
2 - SQL : SELECT /*+ KEEP_JOINED_TABLE
          USE_NL_IN( _A1 )
          FULL( _A2 )
          INDEX( _A1, "PUBLIC"."PART_PK_INDEX" )
          */
          "_A2".L_ORDERKEY, "_A1".P_PARTKEY
FROM ( "SESSION_SCHEMA"."_$NI_5"@LOCAL AS "_A2"
      INNER JOIN
      "PUBLIC"."PART"@LOCAL AS "_A1"
      ON true
      ) ALIAS "_A3"
WHERE "_A1".P_PARTKEY = "_A2".L_PARTKEY
TARGET DOMAIN : G1(G1N1,G1N2) 857 rows,
                G2(G2N1,G2N2) 845 rows,
                G3(G3N1,G3N2) 826 rows
3 - SQL : DECLARE INSTANT TABLE "SESSION_SCHEMA"."_$NI_5"
      ( "L_PARTKEY" NUMBER(10, 0), "L_ORDERKEY" NUMBER(10, 0) )
      COLUMN : LINEITEM.L_PARTKEY AS L_PARTKEY, LINEITEM.L_ORDERKEY AS L_ORDERKEY
      SHARDED : LINEITEM.L_PARTKEY
      TARGET DOMAIN : G1(G1N1,G1N2) 857 rows,
                    G2(G2N1,G2N2) 845 rows,
                    G3(G3N1,G3N2) 826 rows
4 - SQL : SELECT /*+ FULL( _A1 ) */
          "_A1".L_ORDERKEY, "_A1".L_PARTKEY
      FROM "PUBLIC"."LINEITEM"@LOCAL AS "_A1"
      WHERE "_A1".L_SHIPDATE = :_V0
TARGET DOMAIN : G1(G1N1,G1N2) 840 rows,
                G2(G2N1,G2N2) 824 rows,
                G3(G3N1,G3N2) 864 rows
5 - HASH SHARD ( # 3 )
      READ COLUMN : LINEITEM.L_ORDERKEY, LINEITEM.L_PARTKEY, LINEITEM.L_SHIPDATE
      PHYSICAL FILTER : LINEITEM.L_SHIPDATE = DATE'1995-03-15'
7 - TARGET : _A2.L_ORDERKEY, _A1.P_PARTKEY
8 - JOINED COLUMN : _A2.L_ORDERKEY, _A1.P_PARTKEY
      CONSTANT FILTER : TRUE
9 - READ COLUMN : _A2.L_PARTKEY, _A2.L_ORDERKEY
10 - HASH SHARD ( # 3 )
      READ INDEX COLUMN : _A1.P_PARTKEY

```

```

      MIN RANGE : _A1.P_PARTKEY = {_A2.L_PARTKEY}
      MAX RANGE : _A1.P_PARTKEY = {_A2.L_PARTKEY}
      FETCH ONE ROW

```

```
<<< end print plan
```

In the execution plan above, it performs the remote join by creating lineitem as a pusher table whose shard key is l\_partkey, then transferring SQL to each server.

### NO\_PUSHER( alias )

It does not build a table or a view corresponding to an alias as a pusher table when an alias participates in the join.

If the remote join cost of when building a sibling of an alias as a pusher table is big, then a local join can be selected.

In this case, if using it together with REMOTE\_JOIN hint, then it performs the remote join by building a sibling of an alias as a pusher table.

The following is an example of using NO\_PUSHER hint.

```

\EXPLAIN PLAN
SELECT /*+ NO_PUSHER(lineitem) */
      l_orderkey, p_partkey
FROM part, lineitem
WHERE p_partkey = l_partkey
      AND l_shipdate = date '1995-03-15';
>>> start print plan
< Execution Plan >
=====
|IDX|  NODE DESCRIPTION                               |          ROWS |
-----|-----|
| 0 |  SELECT STATEMENT                               |          2528 |
| 1 |    QUERY BLOCK ("$_QB_IDX_2")                   |          2528 |
| 2 |      HASH JOIN (INNER JOIN)                     |          2528 |
| 3 |        PLAN BASED CLUSTER                        | LOCAL/REMOTE 200000 |
| 4 |          INDEX ACCESS ("PART", "PART_PK_INDEX") | (66675) 66675 |
| 5 |            HASH JOIN INSTANT                     |          2528 |
| 6 |              PLAN BASED CLUSTER                  | LOCAL/REMOTE 2528 |
| 7 |                TABLE ACCESS ("LINEITEM")       |           840 |
=====
1 - TARGET : LINEITEM.L_ORDERKEY, PART.P_PARTKEY
2 - JOINED COLUMN : LINEITEM.L_ORDERKEY, PART.P_PARTKEY
3 - SQL : SELECT /*+ INDEX( _A1, "PUBLIC"."PART_PK_INDEX" ) */

```

```

        "_A1"."P_PARTKEY"
      FROM "PUBLIC"."PART"@LOCAL AS "_A1"
    TARGET DOMAIN : G1(G1N1,G1N2) 66675 rows,
                  G2(G2N1,G2N2) 66664 rows,
                  G3(G3N1,G3N2) 66661 rows
4 - HASH SHARD ( # 3 )
    READ INDEX COLUMN : PART.P_PARTKEY
5 - HASH KEY : LINEITEM.L_PARTKEY
    RECORD COLUMN : LINEITEM.L_ORDERKEY
    READ KEY COLUMN : LINEITEM.L_PARTKEY, LINEITEM.L_ORDERKEY
    HASH FILTER : LINEITEM.L_PARTKEY = PART.P_PARTKEY
6 - SQL : SELECT /*+ FULL( _A1 ) */
        "_A1"."L_ORDERKEY", "_A1"."L_PARTKEY"
      FROM "PUBLIC"."LINEITEM"@LOCAL AS "_A1"
    WHERE "_A1"."L_SHIPDATE" = :_V0
    TARGET DOMAIN : G1(G1N1,G1N2) 840 rows,
                  G2(G2N1,G2N2) 824 rows,
                  G3(G3N1,G3N2) 864 rows
7 - HASH SHARD ( # 3 )
    READ COLUMN : LINEITEM.L_ORDERKEY, LINEITEM.L_PARTKEY, LINEITEM.L_SHIPDATE
    PHYSICAL FILTER : LINEITEM.L_SHIPDATE = DATE'1995-03-15'
<<< end print plan

```

In the execution plan above, the local join is performed. If the remote join cost of when building a sibling of an alias as a pusher table is big, then a local join can be selected as follows.

```

\EXPLAIN PLAN
SELECT /*+ REMOTE_JOIN(lineitem) NO_PUSHER(lineitem) */
      l_orderkey, p_partkey
  FROM part, lineitem
 WHERE p_partkey = l_partkey
      AND l_shipdate = date '1995-03-15';
>>> start print plan
< Execution Plan >
=====
|  IDX  |  NODE DESCRIPTION                               |          ROWS |
-----|-----|-----|
|  0  |  SELECT STATEMENT                               |          2528 |
|  1  |    QUERY BLOCK ("$_QB_IDX_2")                   |          2528 |
|  2  |      SINGLE CLUSTER                             | LOCAL/REMOTE 2528 |
|  3  |          CLUSTER PUSHER ("$_$NI_5")             |        200000 |

```

```

| 4 |          PLAN BASED CLUSTER          |LOCAL/REMOTE 200000 |
| 5 |          INDEX ACCESS ("PART", "PART_PK_INDEX")  |(66675) 66675 |
| 6 |          SELECT STATEMENT              |      840 |
| 7 |          QUERY BLOCK ("SQB_IDX_2")        |      840 |
| 8 |          HASH JOIN (INNER JOIN)          |      840 |
| 9 |          PUSHER TABLE ACCESS ("_$_NI_5" AS _A2) | 200000 |
|10 |          HASH JOIN INSTANT              |      840 |
|11 |          TABLE ACCESS ("LINEITEM" AS _A1)    |      840 |

```

```

=====
1 - TARGET : LINEITEM.L_ORDERKEY, $_NI_5.P_PARTKEY
2 - SQL : SELECT /*+ KEEP_JOINED_TABLE
          USE_HASH_IN( _A1, 396 )
          FULL( _A2 )
          FULL( _A1 )
          */
          "_A1".L_ORDERKEY, "_A2".P_PARTKEY
FROM ( "SESSION_SCHEMA"."$_NI_5"@LOCAL AS "_A2"
      INNER JOIN
      "PUBLIC"."LINEITEM"@LOCAL AS "_A1"
      ON "_A1".L_PARTKEY = "_A2".P_PARTKEY
      ) ALIAS "_A3"
WHERE "_A1".L_SHIPDATE = :_V0
TARGET DOMAIN : G1(G1N1,G1N2) 840 rows,
                G2(G2N1,G2N2) 824 rows,
                G3(G3N1,G3N2) 864 rows
3 - SQL : DECLARE INSTANT TABLE "SESSION_SCHEMA"."$_NI_5"
          ( "P_PARTKEY" NUMBER(10, 0) )
COLUMN : PART.P_PARTKEY AS P_PARTKEY
CLONED
TARGET DOMAIN : G1(G1N1,G1N2) 200000 rows,
                G2(G2N1,G2N2) 200000 rows,
                G3(G3N1,G3N2) 200000 rows
4 - SQL : SELECT /*+ INDEX( _A1, "PUBLIC"."PART_PK_INDEX" ) */
          "_A1".P_PARTKEY
FROM "PUBLIC"."PART"@LOCAL AS "_A1"
TARGET DOMAIN : G1(G1N1,G1N2) 66675 rows,
                G2(G2N1,G2N2) 66664 rows,
                G3(G3N1,G3N2) 66661 rows
5 - HASH SHARD ( # 3 )
READ INDEX COLUMN : PART.P_PARTKEY
7 - TARGET : _A1.L_ORDERKEY, _A2.P_PARTKEY

```



```

8 - JOINED COLUMN : _A1.L_ORDERKEY, _A2.P_PARTKEY
9 - READ COLUMN : _A2.P_PARTKEY
10 - HASH KEY : _A1.L_PARTKEY
    RECORD COLUMN : _A1.L_ORDERKEY
    READ KEY COLUMN : _A1.L_PARTKEY, _A1.L_ORDERKEY
    HASH FILTER : _A1.L_PARTKEY = _A2.P_PARTKEY
11 - HASH SHARD ( # 3 )
    READ COLUMN : _A1.L_ORDERKEY, _A1.L_PARTKEY, _A1.L_SHIPDATE
    PHYSICAL FILTER : _A1.L_SHIPDATE = :_V0
<<< end print plan

```

In the execution plan above, it performs the remote join by building a sibling of an alias as a pusher table.

## <group hints>

Those hints are related to *group by* processing, so they are valid only when *group by* clause exists.

## <group operation hints>

### USE\_GROUP\_HASH

If USE\_GROUP\_HASH hint is specified, then an optimizer uses a hash instant to process *group by*.

Generally, a hash instant is used to process *group by*. However, if rows on the subordinate nodes ascend by being sorted for the *group by* key column, then hash instants are not accumulated. Instead, *group by* is processed by comparing the *group by* key column values of rows.

An optimizer does not accumulate hash instants when performing the cost estimation but guides the subordinate node to use an index. However, if the statistics information is incorrect, then the cost of this method can be more expensive. Therefore, use USE\_GROUP\_HASH hint in this case.

The following is an example of using USE\_GROUP\_HASH hint. Compare the execution plan before and after using the hint to figure out the process of USE\_GROUP\_HASH hint.

```

\EXPLAIN PLAN
  SELECT
    c_custkey,
    count(o_orderkey) as c_count
  FROM customer LEFT OUTER JOIN orders
    ON c_custkey = o_custkey
    AND o_comment not like '%special%requests%'
    AND c_mktsegment = 'BUILDING'
  GROUP BY c_custkey;
>>> start print plan

```

< Execution Plan >

```

=====
|  IDX  |  NODE DESCRIPTION  |
-----
|   0   |  SELECT STATEMENT  |
|   1   |    QUERY BLOCK ("QB_IDX_2")  |
|   2   |      GROUP          |
|   3   |        HASH JOIN (LEFT OUTER JOIN)  |
|   4   |          INDEX ACCESS ("CUSTOMER", "CUSTOMER_PK_INDEX")  |
|   5   |            HASH JOIN INSTANT  |
|   6   |              TABLE ACCESS ("ORDERS")  |
=====

1 - TARGET : CUSTOMER.C_CUSTKEY, COUNT( ORDERS.O_ORDERKEY ) AS C_COUNT
2 - GROUP KEY : CUSTOMER.C_CUSTKEY
   RECORD COLUMN : COUNT( ORDERS.O_ORDERKEY )
   READ KEY COLUMN : CUSTOMER.C_CUSTKEY
   READ RECORD COLUMN : COUNT( ORDERS.O_ORDERKEY )
3 - JOINED COLUMN : CUSTOMER.C_CUSTKEY, ORDERS.O_ORDERKEY
4 - READ COLUMN : ORDERS.O_ORDERKEY, ORDERS.O_CUSTKEY, ORDERS.O_COMMENT
   LOGICAL FILTER : ORDERS.O_COMMENT NOT LIKE '%special%requests%'
5 - HASH KEY : CUSTOMER.C_CUSTKEY
   READ KEY COLUMN : CUSTOMER.C_CUSTKEY
   HASH FILTER : CUSTOMER.C_CUSTKEY = ORDERS.O_CUSTKEY
6 - READ INDEX COLUMN : CUSTOMER.C_CUSTKEY

```

<<< end print plan

\EXPLAIN PLAN

```

SELECT /*+ USE_GROUP_HASH */
       c_custkey,
       count(o_orderkey) as c_count
FROM   customer LEFT OUTER JOIN orders
       ON c_custkey = o_custkey
       AND o_comment not like '%special%requests%'
       AND c_mktsegment = 'BUILDING'

GROUP BY c_custkey;

```

>>> start print plan

< Execution Plan >

```

=====
|  IDX  |  NODE DESCRIPTION  |
-----
|   0   |  SELECT STATEMENT  |
|   1   |    QUERY BLOCK ("QB_IDX_2")  |

```

```

| 2 |      GROUP HASH INSTANT          |
| 3 |      HASH JOIN (LEFT OUTER JOIN) |
| 4 |      TABLE ACCESS ("CUSTOMER")  |
| 5 |      HASH JOIN INSTANT           |
| 6 |      TABLE ACCESS ("ORDERS")    |
=====
1 - TARGET : CUSTOMER.C_CUSTKEY, COUNT( ORDERS.O_ORDERKEY ) AS C_COUNT
2 - GROUP KEY : CUSTOMER.C_CUSTKEY
   RECORD COLUMN : COUNT( ORDERS.O_ORDERKEY )
   READ KEY COLUMN : CUSTOMER.C_CUSTKEY
   READ RECORD COLUMN : COUNT( ORDERS.O_ORDERKEY )
3 - JOINED COLUMN : CUSTOMER.C_CUSTKEY, ORDERS.O_ORDERKEY
4 - READ COLUMN : CUSTOMER.C_CUSTKEY, CUSTOMER.C_MKTSEGMENT
5 - HASH KEY : ORDERS.O_CUSTKEY
   RECORD COLUMN : ORDERS.O_ORDERKEY
   READ KEY COLUMN : ORDERS.O_CUSTKEY, ORDERS.O_ORDERKEY
   HASH FILTER : ORDERS.O_CUSTKEY = CUSTOMER.C_CUSTKEY
   LOGICAL FILTER : {CUSTOMER.C_MKTSEGMENT} = 'BUILDING'
6 - READ COLUMN : ORDERS.O_ORDERKEY, ORDERS.O_CUSTKEY, ORDERS.O_COMMENT
   LOGICAL FILTER : ORDERS.O_COMMENT NOT LIKE '%special%requests%'
<<< end print plan

```

### USE\_GROUP\_HASH( hash\_bucket\_count )

USE\_GROUP\_HASH( hash\_bucket\_count ) hint is as same as USE\_GROUP\_HASH hint, but in addition to that it can specify the hash bucket count.

If statistics information is incorrect, then hash bucket count of hash instants created for GROUP BY may be too many or too little so it may degrade the performance. In this case, specify the hash bucket count by using the hint to prevent the performance from degrading.

The following is an example of using USE\_GROUP\_HASH( hash\_bucket\_count ) hint.

```

\EXPLAIN PLAN VERBOSE
SELECT /*+ USE_GROUP_HASH(15000) */
       c_custkey,
       count(o_orderkey) as c_count
FROM   customer LEFT OUTER JOIN orders
       ON c_custkey = o_custkey
       AND o_comment not like '%special%requests%'
       AND c_mktsegment = 'BUILDING'
GROUP BY c_custkey;
>>> start print plan

```

&lt; Execution Plan &gt;

```

=====
|IDX|  NODE DESCRIPTION                               |  ROWS  | Ellipsis |
-----
| 0 |  SELECT STATEMENT                                 | 150000 | ... |
| 1 |    QUERY BLOCK ("QB_IDX_2")                     | 150000 | ... |
| 2 |      GROUP HASH INSTANT                          | 150000 | ... |
| 3 |        HASH JOIN (INVERTED LEFT OUTER JOIN)     | 430506 | ... |
| 4 |          TABLE ACCESS ("ORDERS")                | 1483918 | ... |
| 5 |            HASH JOIN INSTANT                     | 430506 | ... |
| 6 |              TABLE ACCESS ("CUSTOMER")         | 150000 | ... |
=====

1 - TARGET : CUSTOMER.C_CUSTKEY, COUNT( ORDERS.O_ORDERKEY ) AS C_COUNT
2 - GROUP KEY : CUSTOMER.C_CUSTKEY
   RECORD COLUMN : COUNT( ORDERS.O_ORDERKEY )
   READ KEY COLUMN : CUSTOMER.C_CUSTKEY
   READ RECORD COLUMN : COUNT( ORDERS.O_ORDERKEY )
   HASH BUCKET COUNT : 15000
3 - JOINED COLUMN : CUSTOMER.C_CUSTKEY, ORDERS.O_ORDERKEY
4 - READ COLUMN : ORDERS.O_ORDERKEY, ORDERS.O_CUSTKEY, ORDERS.O_COMMENT
   LOGICAL FILTER : ORDERS.O_COMMENT NOT LIKE '%special%requests%'
5 - HASH KEY : CUSTOMER.C_CUSTKEY
   RECORD COLUMN : CUSTOMER.C_MKTSEGMENT
   READ KEY COLUMN : CUSTOMER.C_CUSTKEY
   READ RECORD COLUMN : CUSTOMER.C_MKTSEGMENT
   HASH FILTER : CUSTOMER.C_CUSTKEY = ORDERS.O_CUSTKEY
   PHYSICAL FILTER : CUSTOMER.C_MKTSEGMENT = 'BUILDING'
   HASH BUCKET COUNT : 150000
6 - READ COLUMN : CUSTOMER.C_CUSTKEY, CUSTOMER.C_MKTSEGMENT
<<< end print plan

```

In the example above, the hash bucket count is specified as many as the number of expected output rows of GROUP HASH INSTANT.

## <group driver hints>

Those hints are available when performing *group by* clause in the cluster system. They are ignored in the standalone system.

### LOCAL\_GROUP

It performs *group by* in the current server.

The following is an example of using LOCAL\_GROUP hint.

```

\EXPLAIN PLAN
SELECT /*+ LOCAL_GROUP */
      c_custkey, COUNT(o_orderkey)
FROM customer, orders
WHERE c_custkey = o_custkey
      AND o_orderdate >= date '1993-07-01'
      AND c_nationkey = 1
      AND o_orderstatus = 'F'
      AND o_orderpriority = '2-HIGH'
GROUP BY c_custkey;
>>> start print plan
< Execution Plan >
=====
|IDX|  NODE DESCRIPTION                                | ROWS | |
|---|---|---|---|
| 0 |  SELECT STATEMENT                                | 2094 |
| 1 |    QUERY BLOCK ("$_QB_IDX_2")                    | 2094 |
| 2 |      GROUP HASH INSTANT                          | 2094 |
| 3 |        PLAN BASED CLUSTER                        |LOCAL| 3049 |
| 4 |          NESTED JOIN (INNER JOIN)                | 1004 |
| 5 |            INDEX ACCESS ("CUSTOMER", "CUSTOMER_NATIONKEY_FK") | 5975 |
| 6 |            INDEX ACCESS ("ORDERS", "ORDERS_CUSTKEY_FK")      | 1004 |
=====

1 - TARGET : CUSTOMER.C_CUSTKEY, COUNT( ORDERS.O_ORDERKEY )
2 - GROUP KEY : CUSTOMER.C_CUSTKEY
   RECORD COLUMN : COUNT( ORDERS.O_ORDERKEY )
   READ KEY COLUMN : CUSTOMER.C_CUSTKEY
   READ RECORD COLUMN : COUNT( ORDERS.O_ORDERKEY )
3 - SQL : SELECT /*+ KEEP_JOINED_TABLE
           USE_NL_IN( _A1 )
           INDEX( _A2, "PUBLIC"."CUSTOMER_NATIONKEY_FK" )
           INDEX( _A1, "PUBLIC"."ORDERS_CUSTKEY_FK" )
           */
           "_A2"."C_CUSTKEY", "_A1"."O_ORDERKEY"
FROM ( "PUBLIC"."CUSTOMER"@LOCAL AS "_A2"
      INNER JOIN
      "PUBLIC"."ORDERS"@LOCAL AS "_A1" ON true
      ) ALIAS "_A3"
WHERE "_A2"."C_NATIONKEY" = :_V0

```

```

        AND "_A1"."O_CUSTKEY" = "_A2"."C_CUSTKEY"
        AND "_A1"."O_ORDERSTATUS" = :_V1
        AND "_A1"."O_ORDERDATE" >= :_V2
        AND "_A1"."O_ORDERPRIORITY" = :_V3
    TARGET DOMAIN : G1(G1N1,G1N2) 1004 rows,
                  G2(G2N1,G2N2) 995 rows,
                  G3(G3N1,G3N2) 1050 rows
4  - JOINED COLUMN : CUSTOMER.C_CUSTKEY, ORDERS.O_ORDERKEY
5  - CLONED
    READ INDEX COLUMN : CUSTOMER.C_NATIONKEY
    READ TABLE COLUMN : CUSTOMER.C_CUSTKEY
      MIN RANGE : CUSTOMER.C_NATIONKEY = 1
      MAX RANGE : CUSTOMER.C_NATIONKEY = 1
6  - HASH SHARD ( # 3 )
    READ INDEX COLUMN : ORDERS.O_CUSTKEY
    READ TABLE COLUMN : ORDERS.O_ORDERKEY, ORDERS.O_ORDERSTATUS, ORDERS.O_ORDERDATE,
ORDERS.O_ORDERPRIORITY
      MIN RANGE : ORDERS.O_CUSTKEY = {CUSTOMER.C_CUSTKEY}
      MAX RANGE : ORDERS.O_CUSTKEY = {CUSTOMER.C_CUSTKEY}
      PHYSICAL TABLE FILTER : ORDERS.O_ORDERSTATUS = 'F' AND ORDERS.O_ORDERDATE >=
DATE'1993-07-01' AND ORDERS.O_ORDERPRIORITY = '2-HIGH'
<<< end print plan

```

In the execution plan above, it brings all join results from G1, G2 and G3, then performs *group by* in a local.

Generally, if it is a sharded table, it is recommended to process it with remote group if possible. It is because that it can process grouping in parallel and the intermediate results to be transferred are decreased.

However, if the target rows of group by is few, so the parallel processing effect is not expected, then it is recommended to process *group by* in a local.

## REMOTE\_GROUP

It performs *group by* in a server of each group.

The following is an example of using REMOTE\_GROUP hint.

```

\EXPLAIN PLAN
SELECT /*+ REMOTE_GROUP */
      c_custkey, COUNT(o_orderkey)
  FROM customer, orders
 WHERE c_custkey = o_custkey
 GROUP BY c_custkey;

```

```
>>> start print plan
```

```
< Execution Plan >
```

```
=====
|  IDX  |  NODE DESCRIPTION                               |  ROWS  |
-----|-----|-----|
|  0  |  SELECT STATEMENT                               |  99996 |
|  1  |    QUERY BLOCK ("$_QB_IDX_2")                   |  99996 |
|  2  |      SINGLE CLUSTER                             | LOCAL/REMOTE 99996 |
|  3  |        SELECT STATEMENT                         |  98218 |
|  4  |          QUERY BLOCK ("$_QB_IDX_2")              |  98218 |
|  5  |            GROUP HASH INSTANT                    |  98218 |
|  6  |              HASH JOIN (INNER JOIN)              |  500004 |
|  7  |                TABLE ACCESS ("ORDERS" AS _A2)   |  500004 |
|  8  |                  HASH JOIN INSTANT                |  500004 |
|  9  |                    INDEX ACCESS ("CUSTOMER" AS _A1) |  150000 |
=====
```

```
1 - TARGET : CUSTOMER.C_CUSTKEY, COUNT( ORDERS.O_ORDERKEY )
2 - SQL : SELECT /*+ USE_GROUP_HASH(150000)
           KEEP_JOINED_TABLE
           USE_HASH_IN( _A1, 150000 )
           FULL( _A2 )
           INDEX( _A1, "PUBLIC"."CUSTOMER_PK_INDEX" )
        */
        "_A1"."C_CUSTKEY", COUNT( "_A2"."O_ORDERKEY" )
FROM ( "PUBLIC"."ORDERS"@LOCAL AS "_A2"
      INNER JOIN
      "PUBLIC"."CUSTOMER"@LOCAL AS "_A1"
      ON "_A1"."C_CUSTKEY" = "_A2"."O_CUSTKEY"
      ) ALIAS "_A3"
GROUP BY "_A1"."C_CUSTKEY"
TARGET DOMAIN : G1(G1N1,G1N2) 98218 rows,
                G2(G2N1,G2N2) 98174 rows,
                G3(G3N1,G3N2) 98138 rows

RE-GROUPING
GROUP KEY : CUSTOMER.C_CUSTKEY
AGGREGATION : SUM( COUNT( ORDERS.O_ORDERKEY ) )
4 - TARGET : _A1.C_CUSTKEY, COUNT( _A2.O_ORDERKEY )
5 - GROUP KEY : _A1.C_CUSTKEY
RECORD COLUMN : COUNT( _A2.O_ORDERKEY )
READ KEY COLUMN : _A1.C_CUSTKEY
READ RECORD COLUMN : COUNT( _A2.O_ORDERKEY )
```

```

6 - JOINED COLUMN : _A1.C_CUSTKEY, _A2.O_ORDERKEY
7 - HASH SHARD ( # 3 )
  READ COLUMN : _A2.O_ORDERKEY, _A2.O_CUSTKEY
8 - HASH KEY : _A1.C_CUSTKEY
  READ KEY COLUMN : _A1.C_CUSTKEY
  HASH FILTER : _A1.C_CUSTKEY = _A2.O_CUSTKEY
  FETCH ONE ROW
9 - CLONED
  READ INDEX COLUMN : _A1.C_CUSTKEY

```

```
<<< end print plan
```

In the execution plan above, it processes group by in each server. After processing the join in each server, it groups 500,000 data and outputs 100,000 intermediate results. In this way, it can process the grouping in parallel and decrease intermediate results to be brought to the network.

If processing the example above in a local, then it should bring 1,500,000 join results and perform group by for 1,500,000 results. In this case, it cost for bring 1,500,000 data to the network and for grouping 1,500,000 data at once.

## <group cluster regrouping hints>

Those hints are available when performing *group by* in the cluster system. They are ignored in the stand alone system.

### MERGE\_GROUP

MERGE\_GROUP hint is available when it satisfies the following conditions.

- Group by clause exists.
- It can be performed with remote group.
- The intermediate results ascend from the subordinate node of a group in a state that the order for the group by key column is guaranteed.

Using MERGE\_GROUP hint guarantees the order even after fetching the intermediate results to the driver.

The following is an example of using MERGE\_GROUP hint.

```

\EXPLAIN PLAN
SELECT /*+ MERGE_GROUP */
      o_custkey
FROM orders
WHERE o_custkey > 0
GROUP BY o_custkey;
O_CUSTKEY
-----

```



1  
2  
4  
5  
7  
8  
10  
11  
...  
149992  
149993  
149995  
149996  
149998  
149999

99996 rows selected.

>>> start print plan

< Execution Plan >

```
=====
```

INDEX	NODE DESCRIPTION	ROWS
0	SELECT STATEMENT	99996
1	QUERY BLOCK ("\$_QB_IDX_2")	99996
2	MULTIPLE CLUSTER	LOCAL/REMOTE 99996
3	SELECT STATEMENT	98218
4	QUERY BLOCK ("\$_QB_IDX_2")	98218
5	GROUP	98218
6	INDEX ACCESS ("ORDERS" AS _A1)	500004

```
=====
```

```
1 - TARGET : ORDERS.O_CUSTKEY
2 - SQL : SELECT /*+ INDEX( _A1, "PUBLIC"."ORDERS_CUSTKEY_FK" ) */
        "_A1"."O_CUSTKEY"
        FROM "PUBLIC"."ORDERS"@LOCAL AS "_A1"
        WHERE "_A1"."O_CUSTKEY" > :_V0
        GROUP BY "_A1"."O_CUSTKEY"
        ORDER BY "_A1"."O_CUSTKEY" ASC NULLS LAST
TARGET DOMAIN : G1(G1N1,G1N2) 98218 rows,
                G2(G2N1,G2N2) 98174 rows,
                G3(G3N1,G3N2) 98138 rows
```

#### MERGE GROUPING

SORT KEY : ORDERS.O\_CUSTKEY

```

        GROUP KEY : ORDERS.O_CUSTKEY
4 - TARGET : _A1.O_CUSTKEY
5 - GROUP KEY : _A1.O_CUSTKEY
6 - HASH SHARD ( # 3 )
    READ INDEX COLUMN : _A1.O_CUSTKEY
    MIN RANGE : _A1.O_CUSTKEY > :_V0
    MAX RANGE : _A1.O_CUSTKEY IS NOT NULL

```

```
<<< end print plan
```

In the execution result above, they are output in an order of group key col.

## <distinct hints>

Those hints are related to *distinct* processing, so they are valid only when *distinct* clause exists.

## <distinct operation hints>

### USE\_DISTINCT\_HASH

If USE\_DISTINCT\_HASH hint is specified, then an optimizer uses a hash instant to process *distinct*.

Generally, a hash instant is used to process *distinct*. However, if rows on the subordinate nodes ascend by being sorted for the distinct key column, then hash instants are not accumulated. Instead, *distinct* is processed by comparing the distinct key column values of rows.

An optimizer does not accumulate hash instants when performing the cost estimation but guides the subordinate node to use an index. However, if the statistics information is incorrect, then the cost of this method can be more expensive. Therefore, use USE\_DISTINCT\_HASH hint in this case.

The following is an example of using USE\_DISTINCT\_HASH hint. Compare the execution plan before and after using the hint to figure out the process of USE\_DISTINCT\_HASH hint.

```

EXPLAIN PLAN
  SELECT
    DISTINCT
    c_nationkey
  FROM customer
  WHERE c_comment not like '%special%requests%'
    AND c_nationkey > 5;
>>> start print plan
< Execution Plan >
=====
|  IDX  |  NODE DESCRIPTION  |
-----

```

```

| 0 | SELECT STATEMENT |
| 1 |   QUERY BLOCK ("QB_IDX_2") |
| 2 |     GROUP |
| 3 |       INDEX ACCESS ("CUSTOMER", "CUSTOMER_NATIONKEY_FK") |
=====
1 - TARGET : CUSTOMER.C_NATIONKEY
2 - GROUP KEY : CUSTOMER.C_NATIONKEY
3 - READ INDEX COLUMN : CUSTOMER.C_NATIONKEY
   READ TABLE COLUMN : CUSTOMER.C_COMMENT
   MIN RANGE : CUSTOMER.C_NATIONKEY > 5
   MAX RANGE : CUSTOMER.C_NATIONKEY IS NOT NULL
   LOGICAL TABLE FILTER : CUSTOMER.C_COMMENT NOT LIKE '%special%requests%'
<<< end print plan
\EXPLAIN PLAN
  SELECT /*+ USE_DISTINCT_HASH */
    DISTINCT
    c_nationkey
  FROM customer
  WHERE c_comment not like '%special%requests%'
    AND c_nationkey > 5;
>>> start print plan
< Execution Plan >
=====
| IDX | NODE DESCRIPTION |
=====
| 0 | SELECT STATEMENT |
| 1 |   QUERY BLOCK ("QB_IDX_2") |
| 2 |     GROUP HASH INSTANT |
| 3 |       INDEX ACCESS ("CUSTOMER", "CUSTOMER_NATIONKEY_FK") |
=====
1 - TARGET : CUSTOMER.C_NATIONKEY
2 - GROUP KEY : CUSTOMER.C_NATIONKEY
   READ KEY COLUMN : CUSTOMER.C_NATIONKEY
3 - READ INDEX COLUMN : CUSTOMER.C_NATIONKEY
   READ TABLE COLUMN : CUSTOMER.C_COMMENT
   MIN RANGE : CUSTOMER.C_NATIONKEY > 5
   MAX RANGE : CUSTOMER.C_NATIONKEY IS NOT NULL
   LOGICAL TABLE FILTER : CUSTOMER.C_COMMENT NOT LIKE '%special%requests%'
<<< end print plan

```

**USE\_DISTINCT\_HASH( hash\_\_bucket\_count )**

USE\_DISTINCT\_HASH( hash\_\_bucket\_count ) hint is as same as USE\_DISTINCT\_HASH hint, but in addition to that it can specify the hash bucket count.

If statistics information is incorrect, then hash bucket count of hash instants created for DISTINCT may be too many or too little so it may degrade the performance. In this case, specify the hash bucket count by using the hint to prevent the performance from degrading.

The following is an example of using USE\_DISTINCT\_HASH hint( hash\_bucket\_count ).

```
\EXPLAIN PLAN VERBOSE
  SELECT /*+ USE_DISTINCT_HASH(19) */
        DISTINCT
        c_nationkey
  FROM   customer
 WHERE  c_comment not like '%special%requests%'
        AND c_nationkey > 5;
>>> start print plan
< Execution Plan >
=====
|  IDX  |  NODE DESCRIPTION                                |  ROWS | Ellipsis |
-----|-----|-----|-----|
|  0  | SELECT STATEMENT                                |    19 | ...     |
|  1  |  QUERY BLOCK ("SQB_IDX_2")                      |    19 | ...     |
|  2  |    GROUP HASH INSTANT                          |    19 | ...     |
|  3  |      INDEX ACCESS ("CUSTOMER", "CUSTOMER_NATIONKEY_FK")|111562 | ...     |
=====
1 - TARGET : CUSTOMER.C_NATIONKEY
2 - GROUP KEY : CUSTOMER.C_NATIONKEY
  READ KEY COLUMN : CUSTOMER.C_NATIONKEY
  HASH BUCKET COUNT : 19
3 - READ INDEX COLUMN : CUSTOMER.C_NATIONKEY
  READ TABLE COLUMN : CUSTOMER.C_COMMENT
  MIN RANGE : CUSTOMER.C_NATIONKEY > 5
  MAX RANGE : CUSTOMER.C_NATIONKEY IS NOT NULL
  LOGICAL TABLE FILTER : CUSTOMER.C_COMMENT NOT LIKE '%special%requests%'
<<< end print plan
```

In the example above, the hash bucket count is specified as many as the number of expected output rows of GROUP HASH INSTANT.

## <distinct driver hints>

Those hints are available when performing distinct clause in the cluster system. They are ignored in the standalone system.

### LOCAL\_DISTINCT

It performs distinct in the current server.

The following is an example of using LOCAL\_DISTINCT hint.

```
\EXPLAIN PLAN
SELECT /*+ LOCAL_DISTINCT */
      DISTINCT o_custkey
FROM orders
WHERE o_orderdate = date '1995-03-15'
      AND o_orderstatus = 'F'
      AND o_orderpriority = '2-HIGH';
>>> start print plan
< Execution Plan >
```

IDX	NODE DESCRIPTION	ROWS
0	SELECT STATEMENT	34
1	QUERY BLOCK ("\$_QB_IDX_2")	34
2	GROUP HASH INSTANT	34
3	PLAN BASED CLUSTER	LOCAL/REMOTE 34
4	TABLE ACCESS ("ORDERS")	13

```

1 - TARGET : ORDERS.O_CUSTKEY
2 - GROUP KEY : ORDERS.O_CUSTKEY
   READ KEY COLUMN : ORDERS.O_CUSTKEY
3 - SQL : SELECT /*+ FULL( _A1 ) */
        "_A1"."O_CUSTKEY"
        FROM "PUBLIC"."ORDERS"@LOCAL AS "_A1"
        WHERE "_A1"."O_ORDERSTATUS" = :_V0
          AND "_A1"."O_ORDERDATE" = :_V1
          AND "_A1"."O_ORDERPRIORITY" = :_V2
   TARGET DOMAIN : G1(G1N1,G1N2) 13 rows,
                  G2(G2N1,G2N2) 11 rows,
                  G3(G3N1,G3N2) 10 rows
4 - HASH SHARD ( # 3 )
   READ COLUMN : ORDERS.O_CUSTKEY, ORDERS.O_ORDERSTATUS, ORDERS.O_ORDERDATE,
```

```

ORDERS.O_ORDERPRIORITY
          PHYSICAL FILTER : ORDERS.O_ORDERSTATUS = 'F' AND ORDERS.O_ORDERDATE =
DATE'1995-03-15' AND ORDERS.O_ORDERPRIORITY = '2-HIGH'
<<< end print plan

```

In the execution plan above, it brings intermediate results satisfying conditions from orders to a local, then creates GROUP HASH INSTANT for distinct.

## REMOTE\_DISTINCT

It performs distinct in a server of each group.

The following is an example of using REMOTE\_DISTINCT hint.

```

\EXPLAIN PLAN
SELECT /*+ REMOTE_DISTINCT */
      DISTINCT o_orderstatus
      FROM orders
      WHERE o_orderdate = date '1995-03-15';
>>> start print plan
< Execution Plan >
=====
|  IDX  |  NODE DESCRIPTION                               |          ROWS |
=====
|   0   |  SELECT STATEMENT                               |              3 |
|   1   |  QUERY BLOCK ("$_QB_IDX_2")                     |              3 |
|   2   |  SINGLE CLUSTER                                | LOCAL/REMOTE 3 |
|   3   |  SELECT STATEMENT                               |              3 |
|   4   |  QUERY BLOCK ("$_QB_IDX_2")                     |              3 |
|   5   |  GROUP HASH INSTANT                             |              3 |
|   6   |  TABLE ACCESS ("ORDERS" AS _A1)                |            221 |
=====

1 - TARGET : ORDERS.O_ORDERSTATUS
2 - SQL : SELECT /*+ USE_DISTINCT_HASH(3)
          FULL( _A1 )
          */
          DISTINCT "_A1"."O_ORDERSTATUS"
          FROM "PUBLIC"."ORDERS"@LOCAL AS "_A1"
          WHERE "_A1"."O_ORDERDATE" = :_V0
TARGET DOMAIN : G1(G1N1,G1N2) 3 rows,
                G2(G2N1,G2N2) 3 rows,
                G3(G3N1,G3N2) 3 rows

RE-GROUPING

```

```

          GROUP KEY : ORDERS.O_ORDERSTATUS
4  -  TARGET : _A1.O_ORDERSTATUS
5  -  GROUP KEY : _A1.O_ORDERSTATUS
      READ KEY COLUMN : _A1.O_ORDERSTATUS
6  -  HASH SHARD ( # 3 )
      READ COLUMN : _A1.O_ORDERSTATUS, _A1.O_ORDERDATE
      PHYSICAL FILTER : _A1.O_ORDERDATE = :_V0
<<< end print plan

```

In the execution plan above, it performs remote distinct by transferring SQL including DISTINCT.

## <distinct cluster regrouping hints>

Those hints are available when performing the distinct clause in the cluster system. It is ignored in the standalone system.

### MERGE\_DISTINCT

MERGE\_DISTINCT hint is available when it satisfies the following conditions.

- A distinct clause exists.
- It can be performed with remote distinct.
- The intermediate result ascends from the subordinate node of the distinct node in a state that the order for the distinct key column is guaranteed.

Using MERGE\_DISTINCT hint guarantees the order even after fetching the intermediate result to the driver.

The following is an example of using MERGE\_DISTINCT hint.

```

\EXPLAIN PLAN
SELECT /*+ MERGE_DISTINCT */
      DISTINCT o_custkey
      FROM orders
      WHERE o_custkey > 0
      ORDER BY o_custkey;
O_CUSTKEY
-----
      1
      2
      4
      ...
99996 rows selected.
>>> start print plan

```

## &lt; Execution Plan &gt;

```

=====
|IDX|  NODE DESCRIPTION                               |
-----
| 0 |  SELECT STATEMENT                                   |
| 1 |    QUERY BLOCK ("$_QB_IDX_2")                       |
| 2 |      MULTIPLE CLUSTER                               |
| 3 |        SELECT STATEMENT                             |
| 4 |          QUERY BLOCK ("$_QB_IDX_2")                 |
| 5 |            GROUP                                     |
| 6 |              INDEX ACCESS ("ORDERS" AS _A1, "ORDERS_CUSTKEY_FK") |
=====

1 - TARGET : ORDERS.O_CUSTKEY
2 - SQL : SELECT /*+ INDEX( _A1, "PUBLIC"."ORDERS_CUSTKEY_FK" ) */
          DISTINCT "_A1".O_CUSTKEY
          FROM "PUBLIC"."ORDERS"@LOCAL AS "_A1"
          WHERE "_A1".O_CUSTKEY > :_V0
          ORDER BY "_A1".O_CUSTKEY ASC NULLS LAST
TARGET DOMAIN : G1(G1N1,G1N2) 98218 rows,
                 G2(G2N1,G2N2) 98174 rows,
                 G3(G3N1,G3N2) 98138 rows

MERGE GROUPING
  SORT KEY : ORDERS.O_CUSTKEY
  GROUP KEY : ORDERS.O_CUSTKEY
4 - TARGET : _A1.O_CUSTKEY
5 - GROUP KEY : _A1.O_CUSTKEY
6 - HASH SHARD ( # 3 )
  READ INDEX COLUMN : _A1.O_CUSTKEY
  MIN RANGE : _A1.O_CUSTKEY > :_V0
  MAX RANGE : _A1.O_CUSTKEY IS NOT NULL

<<< end print plan

```

In the execution plan above, *MULTIPLE CLUSTER*(IDX:2) keeps the order for o\_custkey. Therefore, SORT node for ORDER BY is useless, so it is dropped.

## &lt;order hints&gt;

Those hints are related to *order by* processing, so they are valid only when *order by* clause exists.



## <order operation hints>

### USE\_ORDER\_SORT

If USE\_ORDER\_SORT hint is specified, then an optimizer uses a sort instant to process *order by*.

Generally, a sort instant is used to process *order by*. However, if rows on the subordinate nodes ascend by being sorted for the sort key column, then *order by* is processed without accumulating sort instants.

An optimizer does not accumulate sort instants when performing the cost estimation but guides the subordinate node to use an index. However, if the statistics information is incorrect, then the cost of this method can be more expensive. Therefore, use USE\_ORDER\_SORT hint in this case.

The following is an example of using USE\_ORDER\_SORT hint. Compare the execution plan before and after using the hint to figure out the process of USE\_ORDER\_SORT hint.

```
\EXPLAIN PLAN
  SELECT n_nationkey,
         n_name
  FROM nation
 ORDER BY n_nationkey;
>>> start print plan
< Execution Plan >
=====
|  IDX  |  NODE DESCRIPTION                                |
-----|-----|
|    0  |  SELECT STATEMENT                                |
|    1  |    QUERY BLOCK ("SQB_IDX_2")                    |
|    2  |      INDEX ACCESS ("NATION", "NATION_PK_INDEX") |
=====
      1 - TARGET : NATION.N_NATIONKEY, NATION.N_NAME
      2 - READ INDEX COLUMN : NATION.N_NATIONKEY
         READ TABLE COLUMN : NATION.N_NAME
<<< end print plan
\EXPLAIN PLAN
  SELECT /*+ USE_ORDER_SORT */
         n_nationkey,
         n_name
  FROM nation
 ORDER BY n_nationkey;
>>> start print plan
< Execution Plan >
=====
|  IDX  |  NODE DESCRIPTION                                |
```

```

-----
|  0 | SELECT STATEMENT                                |
|  1 |   QUERY BLOCK ("Q$QB_IDX_2")                    |
|  2 |     SORT INSTANT                                |
|  3 |       TABLE ACCESS ("NATION")                  |
=====
      1 - TARGET : NATION.N_NATIONKEY, NATION.N_NAME
      2 - SORT KEY : "NATION.N_NATIONKEY ASC NULLS LAST"
          RECORD COLUMN : NATION.N_NAME
          READ KEY COLUMN : NATION.N_NATIONKEY
          READ RECORD COLUMN : NATION.N_NAME
      3 - READ COLUMN : NATION.N_NATIONKEY, NATION.N_NAME
<<< end print plan

```

### NO\_USE\_ORDER\_SORT

If `NO_USE_ORDER_SORT` hint is specified, then an optimizer makes the row to be sorted for sort key column and ascend from the subordinate node without accumulating sort instant.

```

\EXPLAIN PLAN
  SELECT /*+ NO_USE_ORDER_SORT */
        n_nationkey,
        n_name
  FROM nation
 ORDER BY n_nationkey;
>>> start print plan
< Execution Plan >
=====
|  IDX | NODE DESCRIPTION                                |
-----
|  0 | SELECT STATEMENT                                |
|  1 |   QUERY BLOCK ("Q$QB_IDX_2")                    |
|  2 |     INDEX ACCESS ("NATION", "NATION_PK_INDEX")  |
=====
      1 - TARGET : NATION.N_NATIONKEY, NATION.N_NAME
      2 - READ INDEX COLUMN : NATION.N_NATIONKEY
          READ TABLE COLUMN : NATION.N_NAME
<<< end print plan

```

`SORT INSTANT` does not exist in the execution plan above. Instead, it outputs the result which is sorted for `n_nationkey` by performing `INDEX ACCESS`.

## USE\_ORDER\_LIMIT\_SORT

If `USE_ORDER_LIMIT_SORT` hint is specified, then an optimizer sorts the results by using limit sort method. In this case, it is applicable only when `LIMIT` clause and `ORDER BY` clause are used together.

```
\EXPLAIN PLAN
  SELECT /*+ USE_ORDER_LIMIT_SORT */
        n_nationkey,
        n_name
  FROM nation
 ORDER BY n_nationkey
  LIMIT 10,10;
>>> start print plan
< Execution Plan >

=====
|  IDX  |  NODE DESCRIPTION                                |
-----|-----|
|   0   |  SELECT STATEMENT                                |
|   1   |    QUERY BLOCK ("$_QB_IDX_2")                    |
|   2   |      SORT INSTANT                                |
|   3   |        TABLE ACCESS ("NATION")                  |
=====

  1 - TARGET : NATION.N_NATIONKEY, NATION.N_NAME
  2 - LIMIT SORT
      SORT KEY : "NATION.N_NATIONKEY ASC NULLS LAST"
      RECORD COLUMN : NATION.N_NAME
      READ KEY COLUMN : NATION.N_NATIONKEY
      READ RECORD COLUMN : NATION.N_NAME
  3 - READ COLUMN : NATION.N_NATIONKEY, NATION.N_NAME
<<< end print plan
```

`SORT INSTANT` is performed with `LIMIT SORT` in the execution plan above.

## NO\_USE\_ORDER\_LIMIT\_SORT

If `NO_USE_ORDER_LIMIT_SORT` hint is specified, then an optimizer does not apply limit sort method. The refore, it is processed by creating `SORT INSTANT`, or making the row to be sorted for sort key column and to ascend from the subordinate node.

```
\EXPLAIN PLAN
  SELECT /*+ NO_USE_ORDER_LIMIT_SORT */
        n_nationkey,
        n_name
```

```

FROM nation
ORDER BY n_nationkey
LIMIT 10,10;
>>> start print plan
< Execution Plan >
=====
|  IDX  |  NODE DESCRIPTION  |
-----
|    0  |  SELECT STATEMENT  |
|    1  |  QUERY BLOCK ("SQB_IDX_2")  |
|    2  |  INDEX ACCESS ("NATION", "NATION_PK_INDEX")  |
=====
1 - TARGET : NATION.N_NATIONKEY, NATION.N_NAME
2 - READ INDEX COLUMN : NATION.N_NATIONKEY
   READ TABLE COLUMN : NATION.N_NAME
<<< end print plan

```

LIMIT SORT method is not applied in the execution plan above.

## <order driver hints>

Those hints are available when performing *order by* clause in the cluster system. They are ignored in the standalone system.

### LOCAL\_ORDER

It performs *order by* in the current server.

The following is an example of using LOCAL\_ORDER hint.

```

\EXPLAIN PLAN
SELECT /*+ LOCAL_ORDER */
      o_orderdate, o_orderstatus
FROM orders
WHERE o_orderdate >= date '1993-07-01'
      AND o_orderdate < date '1993-07-01' + interval '1' month
ORDER BY o_orderdate;
>>> start print plan
< Execution Plan >
=====
|  IDX  |  NODE DESCRIPTION  |  ROWS  |
-----
|    0  |  SELECT STATEMENT  |  19319  |
|    1  |  QUERY BLOCK ("SQB_IDX_2")  |  19319  |
=====

```

```

| 2 |          SORT INSTANT          |          19319 |
| 3 |          PLAN BASED CLUSTER    | LOCAL/REMOTE 19319 |
| 4 |          TABLE ACCESS ("ORDERS") |          6453 |
=====
1 - TARGET : ORDERS.O_ORDERDATE, ORDERS.O_ORDERSTATUS
2 - SORT KEY : "ORDERS.O_ORDERDATE ASC NULLS LAST"
   RECORD COLUMN : ORDERS.O_ORDERSTATUS
   READ KEY COLUMN : ORDERS.O_ORDERDATE
   READ RECORD COLUMN : ORDERS.O_ORDERSTATUS
3 - SQL : SELECT /*+ FULL( _A1 ) */
        "_A1"."O_ORDERSTATUS", "_A1"."O_ORDERDATE"
   FROM "PUBLIC"."ORDERS"@LOCAL AS "_A1"
   WHERE "_A1"."O_ORDERDATE" < :_V0
        AND "_A1"."O_ORDERDATE" >= :_V1
   TARGET DOMAIN : G1(G1N1,G1N2) 6453 rows,
                  G2(G2N1,G2N2) 6450 rows,
                  G3(G3N1,G3N2) 6416 rows
4 - HASH SHARD ( # 3 )
   READ COLUMN : ORDERS.O_ORDERSTATUS, ORDERS.O_ORDERDATE
   PHYSICAL FILTER : ORDERS.O_ORDERDATE < DATE'1993-07-01' + CAST( '1' AS
INTERVAL(MONTH) ) AND ORDERS.O_ORDERDATE >= DATE'1993-07-01'

```

## REMOTE\_ORDER

It performs *order by* in a server of each group.

The following is an example of using REMOTE\_ORDER hint.

```

\EXPLAIN PLAN
SELECT /*+ REMOTE_ORDER */
        o_orderdate, o_orderstatus
   FROM orders
   WHERE o_orderdate >= date '1993-07-01'
        AND o_orderdate < date '1993-07-01' + interval '1' month
ORDER BY o_orderdate;
>>> start print plan
< Execution Plan >
=====
|  IDX  |  NODE DESCRIPTION          |          ROWS |
-----|-----|-----|
|   0   |  SELECT STATEMENT          |          19319 |
|   1   |  QUERY BLOCK ("QB_IDX_2")  |          19319 |

```

```

| 2 |          MULTIPLE CLUSTER          | LOCAL/REMOTE 19319 |
| 3 |          SELECT STATEMENT          |                   6453 |
| 4 |          QUERY BLOCK ("SQB_IDX_2") |                   6453 |
| 5 |          SORT INSTANT              |                   6453 |
| 6 |          TABLE ACCESS ("ORDERS" AS _A1) |                   6453 |
=====
1 - TARGET : ORDERS.O_ORDERDATE, ORDERS.O_ORDERSTATUS
2 - SQL : SELECT /*+ USE_ORDER_SORT
          FULL( _A1 )
          */
          "_A1"."O_ORDERDATE", "_A1"."O_ORDERSTATUS"
          FROM "PUBLIC"."ORDERS"@LOCAL AS "_A1"
          WHERE "_A1"."O_ORDERDATE" < :_V0
          AND "_A1"."O_ORDERDATE" >= :_V1
          ORDER BY "_A1"."O_ORDERDATE" ASC NULLS LAST
TARGET DOMAIN : G1(G1N1,G1N2) 6453 rows,
                G2(G2N1,G2N2) 6450 rows,
                G3(G3N1,G3N2) 6416 rows
MERGE SORTING
  SORT KEY : ORDERS.O_ORDERDATE
4 - TARGET : _A1.O_ORDERDATE, _A1.O_ORDERSTATUS
5 - SORT KEY : "_A1.O_ORDERDATE ASC NULLS LAST"
  RECORD COLUMN : _A1.O_ORDERSTATUS
  READ KEY COLUMN : _A1.O_ORDERDATE
  READ RECORD COLUMN : _A1.O_ORDERSTATUS
6 - HASH SHARD ( # 3 )
  READ COLUMN : _A1.O_ORDERSTATUS, _A1.O_ORDERDATE
  PHYSICAL FILTER : _A1.O_ORDERDATE < :_V0 AND _A1.O_ORDERDATE >= :_V1
<<< end print plan

```

## <aggregation hints>

Those hints are available when performing single-row aggregation.

## <aggregation driver hints>

Those hints are available when performing single-row aggregation in the cluster system. It is ignored in the standalone system.

### LOCAL\_AGGR

It performs aggregation in the current server.

The following is an example of using LOCAL\_AGGR hint.

```

\EXPLAIN PLAN
SELECT /*+ LOCAL_AGGR */
      sum(ps_supplycost * ps_availqty) * 0.0001
FROM partsupp,
      supplier,
      nation
WHERE ps_suppkey = s_suppkey
      AND s_nationkey = n_nationkey
      AND n_name = 'GERMANY';
>>> start print plan
< Execution Plan >
=====
|IDX|  NODE DESCRIPTION                               |          ROWS |
-----|-----|
| 0 |  SELECT STATEMENT                               |              1 |
| 1 |    QUERY BLOCK ("$_QB_IDX_2")                   |              1 |
| 2 |      AGGREGATION BY HASH                         |              1 |
| 3 |        PLAN BASED CLUSTER                       | LOCAL/REMOTE 31680 |
| 4 |          NESTED JOIN (INNER JOIN)                |           10508 |
| 5 |            NESTED JOIN (INNER JOIN)              |             396 |
| 6 |              TABLE ACCESS ("NATION")            |              1 |
| 7 |                INDEX ACCESS ("SUPPLIER")          |             396 |
| 8 |                  INDEX ACCESS ("PARTSUPP")        |           10508 |
=====
1 - TARGET : SUM( PARTSUPP.PS_SUPPLYCOST * PARTSUPP.PS_AVAILQTY ) * 0.0001
2 - AGGREGATION : SUM( PARTSUPP.PS_SUPPLYCOST * PARTSUPP.PS_AVAILQTY )
3 - SQL : SELECT /*+ KEEP_JOINED_TABLE
          USE_NL_IN( _A1 )
          USE_NL_IN( _A2 )
          FULL( _A3 )
          INDEX( _A2, "PUBLIC"."SUPPLIER_NATIONKEY_FK" )
          INDEX( _A1, "PUBLIC"."PARTSUPP_SUPPKEY_FK" )
          */
          "_A1"."PS_SUPPLYCOST", "_A1"."PS_AVAILQTY"
FROM ( ( "PUBLIC"."NATION"@LOCAL AS "_A3"
        INNER JOIN
        "PUBLIC"."SUPPLIER"@LOCAL AS "_A2" ON true
        ) ALIAS "_A4"
      INNER JOIN

```

```

        "PUBLIC"."PARTSUPP"@LOCAL AS "_A1" ON true
    ) ALIAS "_A5"
WHERE "_A3"."N_NAME" = :_V0
    AND "_A2"."S_NATIONKEY" = "_A3"."N_NATIONKEY"
    AND "_A1"."PS_SUPPKEY" = "_A2"."S_SUPPKEY"
TARGET DOMAIN : G1(G1N1,G1N2) 10508 rows,
                G2(G2N1,G2N2) 10567 rows,
                G3(G3N1,G3N2) 10605 rows
4 - JOINED COLUMN : PARTSUPP.PS_SUPPLYCOST, PARTSUPP.PS_AVAILQTY
5 - JOINED COLUMN : SUPPLIER.S_SUPPKEY
6 - CLONED
   READ COLUMN : NATION.N_NATIONKEY, NATION.N_NAME
   PHYSICAL FILTER : NATION.N_NAME = 'GERMANY'
7 - CLONED
   READ INDEX COLUMN : SUPPLIER.S_NATIONKEY
   READ TABLE COLUMN : SUPPLIER.S_SUPPKEY
   MIN RANGE : SUPPLIER.S_NATIONKEY = {NATION.N_NATIONKEY}
   MAX RANGE : SUPPLIER.S_NATIONKEY = {NATION.N_NATIONKEY}
8 - HASH SHARD ( # 3 )
   READ INDEX COLUMN : PARTSUPP.PS_SUPPKEY
   READ TABLE COLUMN : PARTSUPP.PS_AVAILQTY, PARTSUPP.PS_SUPPLYCOST
   MIN RANGE : PARTSUPP.PS_SUPPKEY = {SUPPLIER.S_SUPPKEY}
   MAX RANGE : PARTSUPP.PS_SUPPKEY = {SUPPLIER.S_SUPPKEY}
<<< end print plan

```

In the execution plan above, it brings all join results to a local, then performs aggregation.

## REMOTE\_AGG

It performs *aggregation* in a server of each group.

The following is an example of using REMOTE\_AGG hint.

```

\EXPLAIN PLAN
SELECT /*+ REMOTE_AGG */
    sum(ps_supplycost * ps_availqty) * 0.0001
FROM partsupp,
    supplier,
    nation
WHERE ps_suppkey = s_suppkey
    AND s_nationkey = n_nationkey
    AND n_name = 'GERMANY';
>>> start print plan

```



## &lt; Execution Plan &gt;

```

=====
|  IDX  |  NODE DESCRIPTION                               |          ROWS  |
-----|-----|-----|
|  0  |  SELECT STATEMENT                               |                |
|  1  |    QUERY BLOCK ("$_QB_IDX_2")                   |                |
|  2  |      SINGLE CLUSTER                             | LOCAL/REMOTE 1 |
|  3  |        SELECT STATEMENT                         |                |
|  4  |          QUERY BLOCK ("$_QB_IDX_2")             |                |
|  5  |            AGGREGATION BY HASH                  |                |
|  6  |              NESTED JOIN (INNER JOIN)          |          10508 |
|  7  |                NESTED JOIN (INNER JOIN)        |           396  |
|  8  |                  TABLE ACCESS ("NATION" AS _A3) |                |
|  9  |                    INDEX ACCESS ("SUPPLIER" AS _A2) |           396  |
| 10  |                      INDEX ACCESS ("PARTSUPP" AS _A1) |          10508 |
=====

```

```

1 - TARGET : SUM( PARTSUPP.PS_SUPPLYCOST * PARTSUPP.PS_AVAILQTY ) * 0.0001
2 - SQL : SELECT /*+ KEEP_JOINED_TABLE
           USE_NL_IN( _A1 )
           USE_NL_IN( _A2 )
           FULL( _A3 )
           INDEX( _A2, "PUBLIC"."SUPPLIER_NATIONKEY_FK" )
           INDEX( _A1, "PUBLIC"."PARTSUPP_SUPPKEY_FK" )
           */
           SUM( "_A1"."PS_SUPPLYCOST" * "_A1"."PS_AVAILQTY" )
FROM ( ( "PUBLIC"."NATION"@LOCAL AS "_A3"
         INNER JOIN
         "PUBLIC"."SUPPLIER"@LOCAL AS "_A2" ON true
       ) ALIAS "_A4"
       INNER JOIN
       "PUBLIC"."PARTSUPP"@LOCAL AS "_A1" ON true
     ) ALIAS "_A5"
WHERE "_A3"."N_NAME" = :_V0
      AND "_A2"."S_NATIONKEY" = "_A3"."N_NATIONKEY"
      AND "_A1"."PS_SUPPKEY" = "_A2"."S_SUPPKEY"
TARGET DOMAIN : G1(G1N1,G1N2) 1 rows,
                G2(G2N1,G2N2) 1 rows,
                G3(G3N1,G3N2) 1 rows
RE-AGGREGATION
  AGGREGATION : SUM( SUM( PARTSUPP.PS_SUPPLYCOST * PARTSUPP.PS_AVAILQTY ) )
4 - TARGET : SUM( _A1.PS_SUPPLYCOST * _A1.PS_AVAILQTY )

```

```
5 - AGGREGATION : SUM( _A1.PS_SUPPLYCOST * _A1.PS_AVAILQTY )
6 - JOINED COLUMN : _A1.PS_SUPPLYCOST, _A1.PS_AVAILQTY
   CONSTANT FILTER : TRUE
7 - JOINED COLUMN : _A2.S_SUPPKEY
   CONSTANT FILTER : TRUE
8 - CLONED
   READ COLUMN : _A3.N_NATIONKEY, _A3.N_NAME
   PHYSICAL FILTER : _A3.N_NAME = :_V0
9 - CLONED
   READ INDEX COLUMN : _A2.S_NATIONKEY
   READ TABLE COLUMN : _A2.S_SUPPKEY
   MIN RANGE : _A2.S_NATIONKEY = {_A3.N_NATIONKEY}
   MAX RANGE : _A2.S_NATIONKEY = {_A3.N_NATIONKEY}
10 - HASH SHARD ( # 3 )
   READ INDEX COLUMN : _A1.PS_SUPPKEY
   READ TABLE COLUMN : _A1.PS_AVAILQTY, _A1.PS_SUPPLYCOST
   MIN RANGE : _A1.PS_SUPPKEY = {_A2.S_SUPPKEY}
   MAX RANGE : _A1.PS_SUPPKEY = {_A2.S_SUPPKEY}
```

```
<<< end print plan
```

In the execution plan above, it performs aggregation in each server, then performs re-aggregation by bringing the result to a local.

## 15.7 SQL Trace Log

### Overview

SQL trace log records the information about performing a user query which can be analyzed. SQL trace log is created in `$GOLDILOCKS_DATA/trc` directory being separated as independent files such as process ID and a session ID. SQL trace log consists of various information such as a user query, SQL execution plan, and SQL execution time per each SQL process phase, then output.

### Output

`TRACE_LOG_ID` value should be set by using `ALTER SESSION` statement or `ALTER SYSTEM` statement to output SQL trace log. For more information about the set value, refer to `TRACE_LOG_ID` of server property.

Trace log can record both successful SQL query and failed SQL query, and it can be set by combining flag values of `TRACE_LOG_ID`.



SQL query which failed on execution phase of **SQL Processing** is called as a failed SQL query. Therefore, SQL queries failed on a parser, a validator, a rewriter, an enumerator, a code planner, a data planner phases are not recorded on a trace log.

The following is an example of outputting SQL trace log by using `TRACE_LOG_ID` property.

- It outputs both successful SQL statement and failed SQL statement.

```
gSQL> ALTER SESSION SET TRACE_LOG_ID = 110000;  
Session altered.
```

- It outputs both successful SQL statement and the bind value.

```
gSQL> ALTER SYSTEM SET TRACE_LOG_ID = 100010;  
System altered.
```

When set `TRACE_LOG_ID`, which is a property to output SQL trace log, to `ALTER SESSION`, then it is applied only to the corresponding session and operated in it. If it is set to `ALTER SYSTEM`, then it is applied to all sessions of all processes connected to the server then operated in them. Therefore, use `ALTER SESSION`

N to see the SQL trace log of the current session, and use ALTER SYSTEM to see SQL trace log of other processes and other sessions.



If the number of processes and sessions connected to the server when it is set to ALTER SYSTEM, then SQL trace log files are created as many, so be cautious to use it.

SQL trace log file is created under trc directory, and the file name is created as follows.

```
opt_p[process ID]_s[session ID].trc
```

It specifies opt in front of a file name, then identifier p together with process ID, then session ID together with identifier s. The delimiter is \_, and extension is trc. If the data created in the same session of the same process is bigger than the maximum size of SQL trace log file, then the file name is changed by adding the current time at the end of the existing file name. Then, it creates a new file with the current file name and keep recording.

The following is an example of SQL trace log file name.

```
opt_p17104_s12.trc
```

## Output Format

SQL trace log are divided into <SQL query string>, <Execution plan>, <Execution type>, <Bind param value> and <Time info>.

## SQL Query String

It outputs the query input by a user including the current time, whether it is successful and the query processing time, and the output format is as follows.

```
[current time] [whether it is successful][query processing time] SQL statement
```

The date and time in us unit is input in [current time], and if it is successful S is input in [whether it is successful], if it is failed, then F is output. The query processing time is output in us unit, and SQL statement is input by a user.

The query processing time is measure in 10 ms when TRACE\_LOG\_TIME\_DETAIL property is not set to ON. However, if this property is set to ON, then the query processing performance may be degraded.

## Execution Plan

It outputs the execution plan of SQL statement. The form is similar to **Execution Plan**, and the total time column is additionally output on the execution plan node table. The total time output on the statement is the time of processing the entire query, and the total time output on other nodes is the processing time on each node. In this case, the total time is output in 10 ms unit.

Use `TRACE_LOG_TIME_DETAIL` property to output the detailed time. However, if this property is set to `OFF`, then the query processing performance may be degraded.

## Execution Type

When it directly performs the query by executing SQL statement, then it outputs `DIRECT EXECUTE`. When it performs the query by using prepare, it outputs `PREPARE EXECUTE`.

## Bind Param Value

When a bind param value is used in SQL statement, then it outputs the information about the bind param value. When a bind param value is not used in SQL statement, it outputs `No Bind Param`.

## Time Info

It outputs the execution time per each phase of SQL processing. Time info is output being divided into module, time, rate and call. Module outputs the phase name such as parse and validate, and time outputs the actual execution time, and rate outputs the ratio of execution time of each phase to the total execution time. Call outputs how many times each phase is called.

Module consists of 7 phases such as parse, validate, code opt, optimizer, data opt, execute, fetch and total phase. A query is parsed on parse phase, and the parsed query is validated on phase. It is preprocessed to perform SQL optimizer on code opt phase, and SQL optimizer is actually executed on optimizer phase. It is prepared to execute the SQL execution plan on data opt phase, then SQL execution plan is executed on execute phase. Query results are collected like as SELECT statement and the result is returned on fetch phase.

When a plan cache is used, validate, code opt, optimizer may not be called. Time is output in 10 ms unit, so the execution time shorter than 10 ms is output as 0. Also, rate is the ratio of execution time of each phase to the total execution time, so the total is 100%, and the ratio of dividing the execution time of each phase to total is output. In this case, if the execution time of each phase is 0, then it is output as 0%.

Use `TRACE_LOG_TIME_DETAIL` property to output the detailed time. However, if this property is set to `OFF`, then the query processing performance may be degraded.

## Examples

The following is SQL statement which does not have a bind param value.

```
SELECT O_TOTALPRICE, O_ORDERDATE, L_QUANTITY
FROM ORDERS, LINEITEM
WHERE O_ORDERKEY = L_ORDERKEY
AND O_ORDERDATE >= DATE '1996-01-01'
AND L_SHIPMODE = 'AIR';
```

The following SQL trace log is output when executing the SQL statement above after setting TRACE\_LOG\_ID to 101111.

```
[2017-05-25 12:27:59.199657] [S][0.000000] SELECT O_TOTALPRICE, O_ORDERDATE, L_QUANTITY
FROM ORDERS, LINEITEM
WHERE O_ORDERKEY = L_ORDERKEY
AND O_ORDERDATE >= DATE '1996-01-01'
AND L_SHIPMODE = 'AIR'
< Execution Plan >
=====
| IDX | NODE DESCRIPTION                                | ROWS | Total Time |
-----|-----|-----|-----|
| 0 | SELECT STATEMENT                                |      | 0:00:00.00 |
| 1 | NESTED LOOP JOIN (INNER JOIN)                   | 1    | 0:00:00.00 |
| 2 | TABLE ACCESS ("LINEITEM")                      | 2    | 0:00:00.00 |
| 3 | INDEX ACCESS ("ORDERS, ORDERS_PK_INDEX")        | 1    | 0:00:00.00 |
=====
1 - JOINED COLUMNS : ORDERS.O_TOTALPRICE, ORDERS.O_ORDERDATE, LINEITEM.L_QUANTITY
2 - READ COLUMNS : L_ORDERKEY, L_QUANTITY, L_SHIPMODE
   PHYSICAL FILTER : L_SHIPMODE = 'AIR'
3 - READ INDEX COLUMNS : O_ORDERKEY
   READ TABLE COLUMNS : O_TOTALPRICE, O_ORDERDATE
   MIN RANGE : O_ORDERKEY = {L_ORDERKEY}
   MAX RANGE : O_ORDERKEY = {L_ORDERKEY}
   PHYSICAL TABLE FILTER : O_ORDERDATE >= CAST( '1996-01-01' AS DATE )
< Execution Type >
-----
DIRECT EXECUTE
< Bind Param Value >
-----
```

No Bind Param.

< Time Info >

```

=====
| Module      | Time          | Rate          | Call |
|-----|-----|-----|-----|
| Parse       | 0:00:00.00   | 0.00 %       | 1    |
| Validate    | 0:00:00.00   | 0.00 %       | 1    |
| Code Opt    | 0:00:00.00   | 0.00 %       | 1    |
| Optimizer   | 0:00:00.00   | 0.00 %       | 1    |
| Data Opt    | 0:00:00.00   | 0.00 %       | 1    |
| Execute     | 0:00:00.00   | 0.00 %       | 1    |
| Fetch       | 0:00:00.00   | 0.00 %       | 1    |
| Total       | 0:00:00.00   | 100.00 %    |      |
=====

```

The following is SQL statement which has a bind param value.

```

SELECT L_QUANTITY
FROM LINEITEM
WHERE L_SHIPMODE = :V1;

```

The following SQL trace log is output when executing the SQL statement above after setting TRACE\_LOG\_ID to 101111.

```

[2017-05-25 12:27:59.200204] [S][0.000000] SELECT L_QUANTITY
FROM LINEITEM
WHERE L_SHIPMODE = :V1
< Execution Plan >
=====
|  IDX  |  NODE DESCRIPTION          |  ROWS  | Total Time |
|-----|-----|-----|-----|
|   0   |  SELECT STATEMENT          |         | 0:00:00.00 |
|   1   |  TABLE ACCESS ("LINEITEM") |    0   | 0:00:00.00 |
=====
      1 - READ COLUMNS : L_QUANTITY, L_SHIPMODE
          PHYSICAL FILTER : L_SHIPMODE = :V1
< Execution Type >
-----
DIRECT EXECUTE
< Bind Param Value >
-----
      1 - :V1(IN, "AIR")

```

## &lt; Time Info &gt;

```
=====
| Module      | Time          | Rate         | Call |
-----
| Parse       | 0:00:00.00   | 0.00 %      | 1 |
| Validate    | 0:00:00.00   | 0.00 %      | 1 |
| Code Opt    | 0:00:00.00   | 0.00 %      | 1 |
| Optimizer   | 0:00:00.00   | 0.00 %      | 1 |
| Data Opt    | 0:00:00.00   | 0.00 %      | 1 |
| Execute     | 0:00:00.00   | 0.00 %      | 1 |
| Fetch       | 0:00:00.00   | 0.00 %      | 1 |
| Total       | 0:00:00.00   | 100.00 %    |    |
=====
```



**16.**

---

## **Built-in Data Type References**

## 16.1 Aliases of Built-in Data Types

- **BIGINT**
  - It is as same as **NUMBER(19,0)**.
  - Refer to **NUMBER**.
- **BINARY**
  - Refer to **BINARY**.
- **BINARY VARYING**
  - Refer to **BINARY VARYING**.
- **BINARY LONG VARYING**
  - Refer to **BINARY LONG VARYING**.
- **BOOLEAN**
  - Refer to **BOOLEAN**.
- **CHAR**
  - It is as same as **CHARACTER**.
  - Refer to **CHARACTER**.
- **CHARACTER**
  - Refer to **CHARACTER**.
- **CHARACTER VARYING**
  - Refer to **CHARACTER VARYING**.
- **CHARACTER LONG VARYING**
  - Refer to **CHARACTER LONG VARYING**.
- **DATE**
  - Refer to **DATE**.
- **DEC**
  - It is as same as **NUMERIC**.
  - Refer to **NUMERIC**.
- **DECIMAL**
  - It is as same as **NUMERIC**.
  - Refer to **NUMERIC**.
- **DOUBLE**
  - It is as same as **FLOAT(53)**.
  - Refer to **FLOAT**.
- **DOUBLE PRECISION**
  - It is as same as **FLOAT(53)**.
  - Refer to **FLOAT**.
- **FLOAT**
  - Refer to **FLOAT**.
- **FLOAT4**
  - It is as same as **FLOAT(24)**.

- Refer to **FLOAT**.
- **FLOAT8**
  - It is as same as **FLOAT(53)**.
  - Refer to **FLOAT**.
- **INT**
  - It is as same as **NUMBER(10,0)**.
  - Refer to **NUMBER**.
- **INT2**
  - It is as same as **NUMBER(5,0)**.
  - Refer to **NUMBER**.
- **INT4**
  - It is as same as **NUMBER(10,0)**.
  - Refer to **NUMBER**.
- **INT8**
  - It is as same as **NUMBER(19,0)**.
  - Refer to **NUMBER**.
- **INTEGER**
  - It is as same as **NUMBER(10,0)**.
  - Refer to **NUMBER**.
- **INTERVAL**
  - Refer to **INTERVAL**.
- **LONG BINARY VARYING**
  - It is as same as **BINARY LONG VARYING**.
  - Refer to **BINARY LONG VARYING**.
- **LONG CHAR VARYING**
  - It is as same as **CHARACTER LONG VARYING**.
  - Refer to **CHARACTER LONG VARYING**.
- **LONG CHARACTER VARYING**
  - It is as same as **CHARACTER LONG VARYING**.
  - Refer to **CHARACTER LONG VARYING**.
- **LONG VARCHAR**
  - It is as same as **CHARACTER LONG VARYING**.
  - Refer to **CHARACTER LONG VARYING**.
- **NATIVE\_BIGINT**
  - Refer to **NATIVE\_BIGINT**.
- **NATIVE\_DOUBLE**
  - Refer to **NATIVE\_DOUBLE**.
- **NATIVE\_INTEGER**
  - Refer to **NATIVE\_INTEGER**.
- **NATIVE\_REAL**
  - Refer to **NATIVE\_REAL**.

- NATIVE\_SMALLINT
  - Refer to **NATIVE\_SMALLINT**.
- NUMBER
  - Refer to **NUMBER**.
- NUMERIC
  - Refer to **NUMERIC**.
- ROWID
  - Refer to **ROWID**.
- SMALLINT
  - It is as same as NUMBER(5,0).
  - Refer to **NUMBER**.
- TIME
  - Refer to **TIME**.
- TIMESTAMP
  - Refer to **TIMESTAMP**.
- VARBINARY
  - It is as same as BINARY VARYING.
  - Refer to **BINARY VARYING**.
- VARCHAR
  - It is as same as CHARACTER VARYING.
  - Refer to **CHARACTER VARYING**.
- VARCHAR2
  - It is as same as CHARACTER VARYING.
  - Refer to **CHARACTER VARYING**.

## 16.2 BINARY

### Syntax

**BINARY** [ (length) ]

### Syntax Rules and Parameters

- length: It is the binary string length.
  - Range: 1 ~ 2000
  - Default value: 1

### Description

A fixed-length binary string is stored.

If the binary string length to be stored is shorter than the specified length, X'00 ' is stored in the remaining part.

- Storage size: Bytes of the length value

### For More Information

Refer to the followings.

- **BINARY VARYING**
- **BINARY LONG VARYING**

## 16.3 BINARY VARYING

### Syntax

**BINARY VARYING** (length)

### Syntax Rules and Parameters

- length: It is the maximum length of binary string.
  - Range: 1 ~ 4000

### Description

The variable-length binary string is stored.

- Storage size: Bytes of the binary string to be stored
- Alias names: VARBINARY

### For More Information

Refer to the followings.

- **BINARY**
- **BINARY LONG VARYING**

## 16.4 BINARY LONG VARYING

### Syntax

**BINARY LONG VARYING**

### Description

The value of the long variable binary string is stored.

- Maximum storage size: 100 megabytes
- Storage size: Bytes of the binary string to be stored
- Alias names: LONG BINARY VARYING, LONG VARBINARY

It can not be used as a column of the key, so there are limitations as follows.

- It can not be used as a key column of an index.
- It can not be used as the expression of ORDER BY clause.
- It can not be used as the expression of GROUP BY clause.
- It can not be used as the expression of DISTINCT clause.
- It can not be used as the expression of UNION, INTERSECT, EXCEPT clauses.

### For More Information

Refer to the followings.

- **BINARY**
- **BINARY VARYING**

## 16.5 BOOLEAN

### Syntax

**BOOLEAN**

### Description

TRUE or FALSE is stored.

- Storage size: 1 byte.



## 16.6 CHARACTER

### Syntax

CHARACTER [ (length [ CHARACTERS | OCTETS | CHAR | BYTE ] ) ]

### Syntax Rules and Parameters

- length: It is the string length.
  - Range: 1 ~ 2000
  - Default value: 1
- [ CHARACTERS | OCTETS | CHAR | BYTE ]: It is unit of length.
  - CHARACTERS
    - The number of characters
    - CHAR is as same as CHARACTERS.
  - OCTETS
    - The number of bytes
    - BYTE is as same as OCTETS.
  - If omitted, the default is the property value of **CHAR\_LENGTH\_UNITS** which is set when creating database.

### Description

A fixed-length string is stored.

If the length of the string to be stored is shorter than the specified length, white spaces are stored in the remaining part.

- Storage size: Bytes of the length value
- Alias name: CHAR

## For More Information

Refer to the followings.

- **CHARACTER VARYING**
- **CHARACTER LONG VARYING**

## 16.7 CHARACTER VARYING

### Syntax

CHARACTER VARYING ( length [ CHARACTERS | OCTETS | CHAR | BYTE ] )

### Syntax Rules and Parameters

- length: It is the string length.
  - Range: 1 ~ 4000
- [ CHARACTERS | OCTETS | CHAR | BYTE ]: It is unit of length.
  - CHARACTERS
    - The number of characters
    - CHAR is as same as CHARACTERS.
  - OCTETS
    - The number of bytes
    - BYTE is as same as OCTETS.
  - If omitted, the default is the property value of **CHAR\_LENGTH\_UNITS** which is set when creating database.

### Description

The variable-length string is stored.

- Storage size: Bytes of the string to be stored
- Alias names: VARCHAR, VARCHAR2

### For More Information

Refer to the followings.

- CHARACTER
- CHARACTER LONG VARYING

## 16.8 CHARACTER LONG VARYING

### Syntax

CHARACTER LONG VARYING

### Description

The value of the long variable-length string is stored.

- Maximum storage size: 100 megabytes
- Storage size: Bytes of the string to be stored
- Alias names: LONG CHARACTER VARYING, LONG CHAR VARYING, LONG VARCHAR

It can not be used as a column of the key, so there are limitations as follows.

- It can not be used as a key column of an index.
- It can not be used as the expression of ORDER BY clause.
- It can not be used as the expression of GROUP BY clause.
- It can not be used as the expression of DISTINCT clause.
- It can not be used as the expression of UNION, INTERSECT, EXCEPT clauses.

### For More Information

Refer to the followings.

- CHARACTER
- CHARACTER VARYING

## 16.9 DATE

### Syntax

DATE

### Description

It is the date type including YEAR, MONTH, DAY, HOUR, MINUTE and SECOND (excluding fractional seconds).

- Value range: Date value between '4714-11-24 BC' and '9999-12-31 AD'
- Storage size: 8 bytes

### For More Information

Refer to the followings.

- [Date Literals](#)
- [TIME](#)
- [TIMESTAMP](#)

## 16.10 FLOAT

### Syntax

`FLOAT[ ( precision ) ]`

### Syntax Rules and Parameters

- precision: It is the binary precision of significant digits.
  - Precision range: 1 ~ 126
  - Default value: 126

### Description

The floating point value with a binary precision is stored.

- Exponential range: 1E-130 ~ 1E+125
- Storage size: (number of digits in integer part+ 1) / 2 + (number of digits in fractional part + 1) / 2 + 1(exponent, sign)

It has a binary precision value unlike **NUMBER**, **NUMERIC** types.

- Alias names: REAL = FLOAT(24), DOUBLE = FLOAT(53), DOUBLE PRECISION = FLOAT(53), FLOAT4 = FLOAT(24), FLOAT8 = FLOAT(53).

### For More Information

Refer to the followings.

- **NUMBER**
- **NUMERIC**

## 16.11 INTERVAL

### Syntax

```

<interval_type> ::=
    INTERVAL YEAR [ ( leading_precision ) ]
| INTERVAL MONTH [ ( leading_precision ) ]
| INTERVAL DAY [ ( leading_precision ) ]
| INTERVAL HOUR [ ( leading_precision ) ]
| INTERVAL MINUTE [ ( leading_precision ) ]
| INTERVAL SECOND [ ( leading_precision [ , fractional_seconds_precision ] ) ]
| INTERVAL YEAR [ ( leading_precision ) ] TO MONTH
| INTERVAL DAY [ ( leading_precision ) ] TO HOUR
| INTERVAL DAY [ ( leading_precision ) ] TO MINUTE
| INTERVAL DAY [ ( leading_precision ) ] TO SECOND [ ( fractional_seconds_precision ) ]
| INTERVAL HOUR [ ( leading_precision ) ] TO MINUTE
| INTERVAL HOUR [ ( leading_precision ) ] TO SECOND [ ( fractional_seconds_precision ) ]
| INTERVAL MINUTE [ ( leading_precision ) ] TO SECOND [ ( fractional_seconds_precision ) ]

```

### Syntax Rules and Parameters

- INTERVAL YEAR [ ( leading\_precision ) ]: A period of YEAR is stored.
  - leading\_precision
    - The number of digits in YEAR
    - Value range: 2 ~ 6
    - Default value: 2
- INTERVAL MONTH [ ( leading\_precision ) ]: A period of MONTH is stored.
  - leading\_precision
    - The number of digits in MONTH
    - Value range: 2 ~ 6
    - Default value: 2
- INTERVAL YEAR [ ( leading\_precision ) ] TO MONTH: A period of YEAR and MONTH is stored.
  - leading\_precision
    - The number of digits in YEAR
    - Value range: 2 ~ 6

- Default value: 2
- INTERVAL DAY [ ( leading\_precision ) ]: A period of DAY is stored.
  - leading\_precision
    - The number of digits in DAY
    - Value range: 2 ~ 6
    - Default value: 2
- INTERVAL HOUR [ ( leading\_precision ) ]: A period of HOUR is stored.
  - leading\_precision
    - The number of digits in HOUR
    - Value range: 2 ~ 6
    - Default value: 2
- INTERVAL MINUTE [ ( leading\_precision ) ]: A period of MINUTE is stored.
  - leading\_precision
    - The number of digits in MINUTE
    - Value range: 2 ~ 6
    - Default value: 2
- INTERVAL SECOND [ ( leading\_precision [ , fractional\_seconds\_precision ] ) ]: A period of SECOND is stored.
  - leading\_precision
    - The number of digits in SECOND
    - Value range: 2 ~ 6
    - Default value: 2
  - fractional\_seconds\_precision
    - The number of digits in fractional seconds
    - Value range: 0 ~ 6
    - Default value: 6
- INTERVAL DAY [ ( leading\_precision ) ] TO HOUR: A period of DAY and HOUR is stored.
  - leading\_precision
    - The number of digits in DAY
    - Value range: 2 ~ 6
    - Default value: 2
- INTERVAL DAY [ ( leading\_precision ) ] TO MINUTE: A period of DAY, HOUR, and MINUTE is stored.
  - leading\_precision
    - The number of digits in DAY
    - Value range: 2 ~ 6
    - Default value: 2



- INTERVAL DAY [ ( leading\_precision ) ] TO SECOND [ ( fractional\_seconds\_precision ) ]: A period of DAY, HOUR, MINUTE, and SECOND is stored.
  - leading\_precision
    - The number of digits in DAY
    - Value range: 2 ~ 6
    - Default value: 2
  - fractional\_seconds\_precision
    - The number of digits in fractional seconds
    - Value range: 0 ~ 6
    - Default value: 6
  
- INTERVAL HOUR [ ( leading\_precision ) ] TO MINUTE: A period of HOUR and MINUTE is stored.
  - leading\_precision
    - The number of digits in HOUR
    - Value range: 2 ~ 6
    - Default value: 2
  
- INTERVAL HOUR [ ( leading\_precision ) ] TO SECOND [ ( fractional\_seconds\_precision ) ]: A period of HOUR, MINUTE and SECOND is stored.
  - leading\_precision
    - The number of digits in HOUR
    - Value range: 2 ~ 6
    - Default value: 2
  - fractional\_seconds\_precision
    - The number of digits in fractional seconds
    - Value range: 0 ~ 6
    - Default value: 6
  
- INTERVAL MINUTE [ ( leading\_precision ) ] TO SECOND [ ( fractional\_seconds\_precision ) ]: A period of MINUTE and SECOND is stored.
  - leading\_precision
    - The number of digits in MINUTE
    - Value range: 2 ~ 6
    - Default value: 2
  - fractional\_seconds\_precision
    - The number of digits in fractional seconds
    - Value range: 0 ~ 6
    - Default value: 6

## Description

INTERVAL types are classified into YEAR TO MONTH family type and DAY TO SECOND family type depending on the range of value representation as follows.

- YEAR TO MONTH family type: Its storage size is 8 bytes.
  - INTERVAL YEAR
  - INTERVAL MONTH
  - INTERVAL YEAR TO MONTH
  
- DAY TO SECOND family type: Its storage size is 16 bytes.
  - INTERVAL DAY
  - INTERVAL HOUR
  - INTERVAL MINUTE
  - INTERVAL SECOND
  - INTERVAL DAY TO HOUR
  - INTERVAL DAY TO MINUTE
  - INTERVAL DAY TO SECOND
  - INTERVAL HOUR TO MINUTE
  - INTERVAL HOUR TO SECOND
  - INTERVAL MINUTE TO SECOND

If the number which is bigger than number of the specified digits is in the field to which the `leading_precision` is specified, then an error is returned.

If the number which is bigger than number of the specified digits is in the field to which the `fractional_seconds_precision` is specified, it is rounded off.

**Table 16-1** Precisions and value range of the second or later field in INTERVAL \* TO \*

Field	Precision	Value range
MONTH	2	0 ~ 11
HOUR	2	0 ~ 23
MINUTE	2	0 ~ 59
SECOND (interger part)	2	0 ~ 59

## For More Information

Refer to [Interval Literals](#).

## 16.12 NATIVE\_BIGINT

### Syntax

**NATIVE\_BIGINT**

### Description

Signed 8-byte integer is stored.

It is as same as long long data type of C language (8 bytes integer).

- Value range: -9,223,372,036,854,775,808 ~ 9,223,372,036,854,775,807
- Storage size: 8 bytes

## 16.13 NATIVE\_DOUBLE

### Syntax

`NATIVE_DOUBLE`

### Description

Double precision floating-point number (8 bytes) is stored.

It is as same as double data type of C language.

- Exponential range:  $1E-307 \sim 1E+308$
- Storage size: 8 bytes

## 16.14 NATIVE\_INTEGER

### Syntax

**NATIVE\_INTEGER**

### Description

Signed 4 byte integer is stored.

It is as same as integer data type of C language (4 bytes).

- Value range: -2,147,483,648 ~ +2,147,483,647
- Storage size: 4 bytes

## 16.15 NATIVE\_REAL

### Syntax

**NATIVE\_REAL**

### Description

Single precision floating-point number (4 bytes) is stored.

It is as same as float data type of C language.

- Exponential range:  $1E-37 \sim 1E+37$
- Storage size: 4 bytes

## 16.16 NATIVE\_SMALLINT

### Syntax

`NATIVE_SMALLINT`

### Description

Signed 2 byte integer is stored.

It is as same as short data type of C language.

- Value range: -32,768 ~ 32,767
- Storage size: 2 bytes

## 16.17 NUMBER

### Syntax

NUMBER [ ( precision [ , scale ] ) ]

### Syntax Rules and Parameters

- NUMBER: A floating point number without a precision and scale is stored.
  - The range of significant digits: 38
  - Exponential range: 1E-130 ~ 1E+125
  - It is as same as FLOAT (126).
- NUMBER(precision): The integer with significant digits of precision is stored.
  - Precision range: 1 ~ 38
  - The scale value: 0
  - It has a decimal precision value unlike **FLOAT** type.
  - It is as same as NUMBER(precision, 0), NUMERIC(precision, 0).
- NUMBER(precision, scale): A fixed point number with precision and scale is stored.
  - Precision range: 1 ~ 38
  - Scale range: -84 ~ 127
  - It has a decimal precision value unlike **FLOAT** type.
  - It is as same as NUMERIC (precision,scale).
  - Alias names: SMALLINT = NUMBER(5,0), INTEGER = NUMBER(10,0), BIGINT = NUMBER(19,0), INT2 = NUMBER(5,0), INT4 = NUMBER(10,0), INT8 = NUMBER(19,0)

### Description

NUMBER type is similar to NUMERIC type, but if both the precision and scale are omitted, NUMBER type stores the floating point number whose precision and scale are not specified.

- NUMBER without precision, scale: Floating-point number
- NUMERIC without precision, scale: The fixed point number of NUMERIC(38, 0)
- Storage size: (number of digits in integer part + 1) / 2 + (number of digits in fractional part + 1) / 2 + 1(exponent, sign)



## For More Information

Refer to the followings.

- FLOAT
- NUMERIC

## 16.18 NUMERIC

### Syntax

**NUMERIC** [ ( precision [ , scale ] ) ]

### Syntax Rules and Parameters

- precision: It is the decimal precision of significant digits.
  - precision range: 1 ~ 38
  - Default value: 38
- scale: It is the decimal point range.
  - scale range: -84 ~ 127
  - Default value: 0

### Description

A fixed point number with precision and scale is stored.

If the precision and scale are omitted, it means as follows.

- NUMERIC = NUMERIC(38,0)
- NUMERIC(p) = NUMERIC(p,0)

NUMBER type is similar to NUMERIC type, but if both the precision and scale are omitted, NUMBER type stores the floating-point number whose precision and scale are not specified.

- NUMBER without precision, scale: Floating point number
- NUMERIC without precision, scale: Fixed point number of NUMERIC(38,0)
- Storage size: (number of digits in integer part + 1) / 2 + (number of digits in fractional part + 1) / 2 + 1(exponent, sign)

## For More Information

Refer to the followings.

- **FLOAT**
- **NUMBER**

# 16.19 ROWID

## Syntax

ROWID

## Description

A record identifier (ROWID) is stored.

A record identifier (ROWID) is the identification information of each record in database.

When querying the ROWID pseudo column, each record identifier (ROWID) is obtained. This ROWID pseudo column has the ROWID data type information.

ROWID type consists of the followings in a stand-alone system.

- OBJECT\_ID
- TABLESPACE\_ID
- PAGE\_ID
- OFFSET within PAGE

ROWID type consists of the followings in a cluster system.

- GRID\_BLOCK\_SEQUENCE
- GRID\_BLOCK\_ID
- MEMBER\_ID
- SHARD\_ID

ROWID is stored in the base 64 value, which can include A ~ Z, a ~ z, 0 ~ 9, +, /.

Each component information of ROWID is obtained using ROWID-related functions.

- Storage size: 16 bytes

## For More Information

Refer to the followings.

- [ROWID Pseudo Column](#)
- [ROWID-related Functions](#)

## 16.20 TIME

### Syntax

```
TIME [ ( fractional_seconds_precision ) ] [ WITH TIME ZONE | WITHOUT TIME ZONE ]
```

### Syntax Rules and Parameters

- `fractional_seconds_precision`: It is the number of significant digits in fractional seconds.
  - `fractional_seconds_precision` range: 0 ~ 6
  - Default value: 6
- `[ WITH TIME ZONE | WITHOUT TIME ZONE ]`: It specifies whether to store TIME ZONE value.
  - `WITH TIME ZONE`: The time which includes time zone
  - `WITHOUT TIME ZONE`: The time which does not include time zone
  - Default value: `WITHOUT TIME ZONE`

### Description

The time which includes HOUR, MINUTE and SECOND is stored.

- Storage size
  - `TIME WITHOUT TIME ZONE`: 8 bytes
  - `TIME WITH TIME ZONE`: 12 bytes

### For More Information

Refer to the followings.

- [Time Literals](#)
- [Time with Time Zone Literals](#)
- [DATE](#)
- [TIMESTAMP](#)

## 16.21 TIMESTAMP

### Syntax

```
TIMESTAMP [ ( fractional_seconds_precision ) ] [ WITH TIME ZONE | WITHOUT TIME ZONE ]
```

### Syntax Rules and Parameters

- `fractional_seconds_precision`: It is the number of significant digits in the fractional seconds.
  - `fractional_seconds_precision` range: 0 ~ 6
  - Default value: 6
- `[ WITH TIME ZONE | WITHOUT TIME ZONE ]`: It specifies whether to store TIME ZONE value.
  - `WITH TIME ZONE`: The time which includes time zone.
  - `WITHOUT TIME ZONE`: The time which does not include time zone.
  - Default value: `WITHOUT TIME ZONE`

### Description

The time which includes YEAR, MONTH, DATE, HOUR, MINUTE and SECOND is stored.

- Storage size
  - `TIMESTAMP WITHOUT TIME ZONE`: 8 bytes
  - `TIMESTAMP WITH TIME ZONE`: 12 bytes

### For More Information

Refer to the followings.

- [Timestamp Literals](#)
- [Timestamp with Time Zone Literals](#)
- [DATE](#)
- [TIME](#)

**17.**

---

## **Built-in Function References**

## 17.1 \* (MULTIPLICATION)

### Syntax

```
expr1 * expr2
```

### Description

It returns the multiplication result of expr1 and expr2.

The multiplication types and result types are as follows.  
For more information, refer to **Type Conversion**.

**Table 17-1** Numeric \* operation

expr1 (expr2)	expr2 (expr1)	Result type
NATIVE INTEGER family <ul style="list-style-type: none"> <li>NATIVE_SMALLINT</li> <li>NATIVE_INTEGER</li> <li>NATIVE_BIGINT</li> </ul>	NATIVE INTEGER family <ul style="list-style-type: none"> <li>NATIVE_SMALLINT</li> <li>NATIVE_INTEGER</li> <li>NATIVE_BIGINT</li> </ul>	NATIVE_BIGINT
NUMBER	NUMBER	NUMBER
NATIVE DOUBLE family <ul style="list-style-type: none"> <li>NATIVE_REAL</li> <li>NATIVE_DOUBLE</li> </ul>	NATIVE DOUBLE family <ul style="list-style-type: none"> <li>NATIVE_REAL</li> <li>NATIVE_DOUBLE</li> </ul>	NATIVE_DOUBLE

**Table 17-2** INTERVAL \* operation

expr1 (expr2)	expr2 (expr1)	Result type
INTERVAL YEAR TO MONTH	Numeric type	INTERVAL YEAR TO MONTH (The result type is the interval type.)
INTERVAL DAY TO SECOND	Numeric type	INTERVAL DAY TO SECOND (The result type is the interval type.)
Refer to <b>INTERVAL type details</b> which is included in <b>INTERVAL type</b> written in the following table.		

**Table 17-3** INTERVAL type details which is included in INTERVAL type written in the following table

INTERVAL YEAR TO MONTH	INTERVAL DAY TO SECOND
	<ul style="list-style-type: none"> <li>INTERVAL DAY</li> <li>INTERVAL HOUR</li> <li>INTERVAL MINUTE</li> </ul>



INTERVAL YEAR TO MONTH	INTERVAL DAY TO SECOND
<ul style="list-style-type: none"> <li>• INTERVAL YEAR</li> <li>• INTERVAL MONTH</li> <li>• INTERVAL YEAR TO MONTH</li> </ul>	<ul style="list-style-type: none"> <li>• INTERVAL SECOND</li> <li>• INTERVAL DAY TO HOUR</li> <li>• INTERVAL DAY TO MINUTE</li> <li>• INTERVAL DAY TO SECOND</li> <li>• INTERVAL HOUR TO MINUTE</li> <li>• INTERVAL HOUR TO SECOND</li> <li>• INTERVAL MINUTE TO SECOND</li> </ul>

## Example

```
gSQL> SELECT INTERVAL '1-2' YEAR TO MONTH * 2 AS RESULT FROM DUAL;
```

```
RESULT
```

```
-----  
+000002-04
```

```
1 row selected.
```

```
gSQL> SELECT INTERVAL '1 01:02:03.400000' DAY TO SECOND * 2 AS RESULT  
FROM DUAL;
```

```
RESULT
```

```
-----  
+000002 02:04:06.800000
```

```
1 row selected.
```

## 17.2 + (ADDITION)

### Syntax

```
expr1 + expr2
```

### Description

It returns the addition result of expr1 and expr2.

The addition types and result types are as follows.

For more information, refer to **Type Conversion**.

**Table 17-4** Numeric + operation

expr1 (expr2)	expr2 (expr1)	Result type
NATIVE INTEGER family <ul style="list-style-type: none"> <li>NATIVE_SMALLINT</li> <li>NATIVE_INTEGER</li> <li>NATIVE_BIGINT</li> </ul>	NATIVE INTEGER family <ul style="list-style-type: none"> <li>NATIVE_SMALLINT</li> <li>NATIVE_INTEGER</li> <li>NATIVE_BIGINT</li> </ul>	NATIVE_BIGINT
NUMBER	NUMBER	NUMBER
NATIVE DOUBLE family <ul style="list-style-type: none"> <li>NATIVE_REAL</li> <li>NATIVE_DOUBLE</li> </ul>	NATIVE DOUBLE family <ul style="list-style-type: none"> <li>NATIVE_REAL</li> <li>NATIVE_DOUBLE</li> </ul>	NATIVE_DOUBLE

**Table 17-5** (DATETIME/INTERVAL) + operation

expr1 (expr2)	expr2 (expr1)	Result type
DATE	NUMERIC	DATE
DATE	INTERVAL YEAR TO MONTH	DATE
DATE	INTERVAL DAY	DATE
DATE	INTERVAL DAY TO SECOND	TIMESTAMP
TIME	NUMERIC	TIME
TIME	INTERVAL YEAR TO MONTH	TIME
TIME	INTERVAL DAY TO SECOND	TIME
TIME WITH TIME ZONE	NUMERIC	TIME WITH TIME ZONE
TIME WITH TIME ZONE	INTERVAL YEAR TO MONTH	TIME WITH TIME ZONE
TIME WITH TIME ZONE	INTERVAL DAY TO SECOND	TIME WITH TIME ZONE
TIMESTAMP	NUMERIC	TIMESTAMP

expr1 (expr2)	expr2 (expr1)	Result type
TIMESTAMP	INTERVAL YEAR TO MONTH	TIMESTAMP
TIMESTAMP	INTERVAL DAY TO SECOND	TIMESTAMP
TIMESTAMP WITH TIME ZONE	NUMERIC	TIMESTAMP WITH TIME ZONE
TIMESTAMP WITH TIME ZONE	INTERVAL YEAR TO MONTH	TIMESTAMP WITH TIME ZONE
TIMESTAMP WITH TIME ZONE	INTERVAL DAY TO SECOND	TIMESTAMP WITH TIME ZONE
INTERVAL YEAR TO MONTH	INTERVAL YEAR TO MONTH	INTERVAL YEAR TO MONTH (The result type includes all the interval range of expr1 and expr2.)
INTERVAL DAY TO SECOND	INTERVAL DAY TO SECOND	INTERVAL DAY TO SECOND (The result type includes all the interval range of expr1 and expr2.)

Refer to **INTERVAL** type details which is included in **INTERVAL** type written in the following table.

## Example

```
gSQL> SELECT TO_DATE( '2012-05-05', 'YYYY-MM-DD' ) + 5 AS RESULT FROM DUAL;
```

```
RESULT
```

```
-----  
2012-05-10
```

```
1 row selected.
```

```
gSQL> SELECT
```

```
    TO_DATE( '2012-05-05', 'YYYY-MM-DD' ) + INTERVAL'01-01'YEAR TO MONTH
```

```
    AS RESULT
```

```
    FROM DUAL;
```

```
RESULT
```

```
-----  
2013-06-05
```

```
1 row selected.
```

```
gSQL> SELECT
```

```
    INTERVAL'01-01'YEAR TO MONTH + INTERVAL'02-10'YEAR TO MONTH
```

```
    AS RESULT
```

```
    FROM DUAL;
```

```
RESULT
```

```
-----  
+000003-11
```

```
1 row selected.
```

## 17.3 + (POSITIVE)

### Syntax

```
+ expr
```

### Description

The + sign is displayed in expr.

### Example

```
gSQL> SELECT +3 AS RESULT1, +(-3) AS RESULT2 FROM DUAL;  
RESULT1 RESULT2  
-----  
3      -3  
1 row selected.
```

## 17.4 - (NEGATIVE)

### Syntax

| - expr

### Description

The - sign is displayed in expr.

### Example

```
gSQL> SELECT -3 AS RESULT1, -(-3) AS RESULT2 FROM DUAL;  
RESULT1 RESULT2  
-----  
-3      3  
1 row selected.
```

## 17.5 - (SUBTRACTION)

### Syntax

```
expr1 - expr2
```

### Description

It returns the subtraction result of expr1 and expr2.

The subtraction types and result types are as follows.

For more information, refer to **Type Conversion**.

**Table 17-6** Numeric - operation

expr1	expr2	Result type
NATIVE INTEGER family <ul style="list-style-type: none"> <li>NATIVE_SMALLINT</li> <li>NATIVE_INTEGER</li> <li>NATIVE_BIGINT</li> </ul>	NATIVE INTEGER family <ul style="list-style-type: none"> <li>NATIVE_SMALLINT</li> <li>NATIVE_INTEGER</li> <li>NATIVE_BIGINT</li> </ul>	NATIVE_BIGINT
NUMBER	NUMBER	NUMBER
NATIVE DOUBLE family <ul style="list-style-type: none"> <li>NATIVE_REAL</li> <li>NATIVE_DOUBLE</li> </ul>	NATIVE DOUBLE family <ul style="list-style-type: none"> <li>NATIVE_REAL</li> <li>NATIVE_DOUBLE</li> </ul>	NATIVE_DOUBLE

**Table 17-7** (DATETIME/INTERVAL) - operation

expr1	expr2	Result type
DATE	DATE	NUMBER
DATE	Numeric type	DATE
DATE	INTERVAL YEAR TO MONTH	DATE
DATE	INTERVAL DAY	DATE
DATE	INTERVAL DAY TO SECOND	TIMESTAMP
TIME	TIME	INTERVAL DAY TO SECOND
TIME	Numeric type	TIME
TIME	INTERVAL YEAR TO MONTH	TIME
TIME	INTERVAL DAY TO SECOND	TIME
TIME WITH TIME ZONE	Numeric type	TIME WITH TIME ZONE
TIME WITH TIME ZONE	INTERVAL YEAR TO MONTH	TIME WITH TIME ZONE

expr1	expr2	Result type
TIME WITH TIME ZONE	INTERVAL DAY TO SECOND	TIME WITH TIME ZONE
TIMESTAMP	TIMESTAMP	INTERVAL DAY TO SECOND
TIMESTAMP	Numeric type	TIMESTAMP
TIMESTAMP	INTERVAL YEAR TO MONTH	TIMESTAMP
TIMESTAMP	INTERVAL DAY TO SECOND	TIMESTAMP
TIMESTAMP WITH TIME ZONE	TIMESTAMP WITH TIME ZONE	INTERVAL DAY TO SECOND
TIMESTAMP WITH TIME ZONE	Numeric type	TIMESTAMP WITH TIME ZONE
TIMESTAMP WITH TIME ZONE	INTERVAL YEAR TO MONTH	TIMESTAMP WITH TIME ZONE
TIMESTAMP WITH TIME ZONE	INTERVAL DAY TO SECOND	TIMESTAMP WITH TIME ZONE
INTERVAL YEAR TO MONTH	INTERVAL YEAR TO MONTH	INTERVAL YEAR TO MONTH (The result type includes all the interval range of expr1 and expr2.)
INTERVAL DAY TO SECOND	INTERVAL DAY TO SECOND	INTERVAL DAY TO SECOND (The result type includes all the interval range of expr1 and expr2.)

Refer to **Table 17-3 INTERVAL type details** which is included in **INTERVAL type** written in the following table.

## Example

```

gSQL> SELECT
    TO_DATE( '2012-05-05' ) - TO_DATE( '2012-05-01' ) AS RESULT
    FROM DUAL;
RESULT
-----
      4
1 row selected.
gSQL> SELECT TO_DATE( '2012-05-05' ) - 3 AS RESULT FROM DUAL;
RESULT
-----
2012-05-02
1 row selected.
gSQL> SELECT
    TO_DATE( '2012-05-05' ) - INTERVAL'01-02'YEAR TO MONTH AS RESULT
    FROM DUAL;
RESULT
-----
2011-03-05
1 row selected.

```

```
gSQL> SELECT
    INTERVAL '05-01' YEAR TO MONTH - INTERVAL '02-01' YEAR TO MONTH
    AS RESULT
    FROM DUAL;
```

RESULT

```
-----
+000003-00
```

1 row selected.

```
gSQL> SELECT INTERVAL '15 23:59:59.999999' DAY TO SECOND
    - INTERVAL '10 23:59:59.999999' DAY TO SECOND AS RESULT
    FROM DUAL;
```

RESULT

```
-----
+000005 00:00:00.000000
```

1 row selected.



## 17.6 / (DIVISION)

### Syntax

```
expr1 / expr2
```

### Description

It returns the division result of expr1 and expr2.

The division types and result types are as follows.

For more information, refer to **Type Conversion**.

**Table 17-8** Numeric / operation

expr1	expr2	Result type
NATIVE INTEGER family <ul style="list-style-type: none"> <li>NATIVE_SMALLINT</li> <li>NATIVE_INTEGER</li> <li>NATIVE_BIGINT</li> </ul>	NATIVE INTEGER family <ul style="list-style-type: none"> <li>NATIVE_SMALLINT</li> <li>NATIVE_INTEGER</li> <li>NATIVE_BIGINT</li> </ul>	NATIVE_DOUBLE
NUMBER	NUMBER	NUMBER
NATIVE_DOUBLE	NATIVE_DOUBLE	NATIVE_DOUBLE

**Table 17-9** (DATETIME/INTERVAL) / operation

expr1	expr2	Result type
INTERVAL YEAR TO MONTH	Numeric type	INTERVAL YEAR TO MONTH (The result type is interval type.)
INTERVAL DAY TO SECOND	Numeric type	INTERVAL DAY TO SECOND (The result type is interval type.)
Refer to <b>INTERVAL</b> type details which is included in <b>INTERVAL</b> type written in the following table.		

### Example

```
gSQL> SELECT INTERVAL'20-10'YEAR TO MONTH / 2 AS RESULT FROM DUAL;
```

```
RESULT
```

```
-----
```

```
+000010-05
```

```
1 row selected.
```

```
gSQL> SELECT INTERVAL'02 02:04:06.800000'DAY TO SECOND / 2 AS RESULT  
FROM DUAL;
```

```
RESULT
```

```
-----  
+000001 01:02:03.400000
```

```
1 row selected.
```

## 17.7 || (CONCATENATE)

### Syntax

```
str1 || str2
```

### Description

CONCATENATE returns the string concatenating str1 and str2.

If either str1 or str2 is NULL, the string except NULL is returned. If both of str1 and str2 are NULL, NULL is returned.

The argument can be a type which can be converted to either character string type or binary string type. For more information, refer to **Type Conversion**.

It is an alias of **CONCAT**, **CONCATENATE**.

The result types are as follows.

**Table 17-10** The result types of || (CONCATENATE)

Data type	CHAR	VARCHAR	LONG VARCHAR
CHAR	CHAR	VARCHAR	LONG VARCHAR
VARCHAR	VARCHAR	VARCHAR	LONG VARCHAR
LONG VARCHAR	LONG VARCHAR	LONG VARCHAR	LONG VARCHAR
Data type	BINARY	VARBINARY	LONG VARBINARY
BINARY	BINARY	VARBINARY	LONG VARBINARY
VARBINARY	VARBINARY	VARBINARY	LONG VARBINARY
LONG VARBINARY	LONG VARBINARY	LONG VARBINARY	LONG VARBINARY

### Example

```
gSQL> SELECT 'DATA' || 'BASE' AS RESULT1,
           'DATA' || NULL AS RESULT2,
           NULL || NULL AS RESULT3
FROM DUAL;
```

```
RESULT1  RESULT2  RESULT3
-----  -----  -----
DATABASE DATA    null
1 row selected.
```

## 17.8 ABS

### Syntax

```
ABS( num )
```

### Description

ABS returns the absolute value of num.

The num argument can be a numeric type or types which can be converted to number. If num is NULL, then it returns NULL.

### Example

```
gSQL> SELECT ABS(-1) AS RESULT1, ABS(1) AS RESULT2 FROM DUAL;  
RESULT1 RESULT2  
-----  
1      1  
1 row selected.
```

## 17.9 ACOS

### Syntax

```
ACOS( num )
```

### Description

ACOS returns the arc cosine value of num.

The num argument should be in the range of -1 to 1.

If num is NULL, then it returns NULL.

It returns the radians value in the range of 0 and pi.

### Example

```
gSQL> SELECT ACOS( 1 ) FROM DUAL;
```

```
ACOS( 1 )
```

```
-----
```

```
0
```

```
1 row selected.
```

## 17.10 ADDDATE

### Syntax

```
ADDDATE( date, INTERVAL expr unit )  
ADDDATE( expr, days )
```

### Description

ADDDATE adds the second argument to the first argument, then returns the result.

If any of the input argument value is NULL, the result is also NULL.

The first argument data type can be DATE, TIMESTAMP, TIMESTAMP WITH TIME ZONE, and the second argument data type can be INTERVAL or numeric.

The result type is as same as **(DATETIME/INTERVAL) + operation**.

### Example

```
gSQL> SELECT ADDDATE( TO_DATE( '2012-12-12', 'YYYY-MM-DD' ), 1 ) AS RESULT  
          FROM DUAL;  
RESULT  
-----  
2012-12-13  
1 row selected.  
gSQL> SELECT ADDDATE( TO_DATE( '2012-11-11', 'YYYY-MM-DD' ),  
                      INTERVAL'01-01'YEAR TO MONTH ) AS RESULT  
          FROM DUAL;  
RESULT  
-----  
2013-12-11  
1 row selected.
```

## 17.11 ADDTIME

### Syntax

```
ADDTIME( expr1, expr2 )
```

### Description

ADDTIME adds expr2 to expr1, then returns the result.

expr1 data type can be TIME, TIME WITH TIME ZONE, TIMESTAMP, TIMESTAMP WITH TIME ZONE TYPE, and expr2 data type can be INTERVAL DAY TO SECOND TYPE.

If expr1 or expr2 is NULL, the result is NULL.

The result type is as same as **(DATETIME/INTERVAL) + operation**.

### Example

```
gSQL> SELECT
      ADDTIME( TO_TIMESTAMP( '2001-05-05 06:00:00',
                           'YYYY-MM-DD HH24:MI:SS' ),
              INTERVAL '0 00:06:06.666666'DAY TO SECOND ) AS RESULT
      FROM DUAL;
RESULT
-----
2001-05-05 06:06:06.666666
1 row selected.
```



## 17.12 ADD\_MONTHS

### Syntax

```
ADD_MONTHS( date, number )
```

### Description

ADD\_MONTHS adds as many month as the number to the date, then returns the result.

After ADD\_MONTHS operation, if the date is bigger than the last day of the month, it is adjusted to the last day of the month.

The data type of date argument can be DATE, TIMESTAMP, TIMESTAMP WITH TIME ZONE, and the number argument can be a numeric type.

If any of the input argument is NULL, the result is also NULL.

The result type is always DATE regardless of the input argument date type.

### Example

```
gSQL> SELECT
      ADD_MONTHS( TO_DATE( '2001-07-31', 'YYYY-MM-DD' ), 1 ) AS RESULT1,
      ADD_MONTHS( TO_DATE( '2001-07-31', 'YYYY-MM-DD' ), 2 ) AS RESULT2
    FROM DUAL;
RESULT1    RESULT2
-----
2001-08-31 2001-09-30
1 row selected.
```

## 17.13 ASCII

### Syntax

ASCII( char )

### Description

It returns the database character set code of the first character of char in decimal form.

The data type of char can be a character type such as CHARACTER, CHARACTER VARYING, CHARACTER LONG VARYING or can be a type which can be converted to a character type, and the return type is NUMBER.

If char is NULL, then it returns NULL.

### Example

```
gSQL> SELECT ASCII( 'G' ) AS RESULT FROM DUAL;
```

```
RESULT
```

```
-----
```

```
       71
```

```
1 row selected.
```

## 17.14 ASIN

### Syntax

```
ASIN( num )
```

### Description

ASIN returns the arc sin value of num.

The num argument should be in the range of -1 to 1.  
If num is NULL, then it returns NULL.

It returns the radians value in the range of  $-\pi/2$  and  $\pi/2$ .

### Example

```
gSQL> SELECT ASIN( 0 ) FROM DUAL;  
ASIN( 0 )  
-----  
          0  
1 row selected.
```

## 17.15 ATAN

### Syntax

```
ATAN( num )
```

### Description

ATAN returns the arc tangent value of num.

The num value range is not limited. It returns the radians value in the range of  $-\pi/2$  and  $\pi/2$ . If num is NULL, then it returns NULL.

### Example

```
gSQL> SELECT ATAN(0.5) FROM DUAL;  
          ATAN(0.5)  
-----  
.463647609000806  
1 row selected.
```

## 17.16 ATAN2

### Syntax

```
ATAN2( num1, num2 )
```

### Description

ATAN2 returns the arc tangent value of num1 and num2.

The num1 argument value range is not limited. It returns the radians value in the range of  $-\pi$  and  $\pi$ . Either num1 or num2 is NULL, then it returns NULL.

### Example

```
gSQL> SELECT ATAN2(1,2) FROM DUAL;  
      ATAN2(1,2)  
-----  
.463647609000806  
1 row selected.
```

## 17.17 AVG

### Syntax

```
AVG( [ ALL | DISTINCT ] num )
```

### Description

It is an aggregate function, and it obtains average value of exprs.

If ALL is explicitly specified, aggregation is executed for all values.

If DISTINCT is explicitly specified, aggregation is executed for the values which exclude duplicate values.

If ALL or DISTINCT is not explicitly specified, it is processed in the same way as when ALL is specified.

### Example

```
gSQL> SELECT AVG(c1) FROM t1;
AVG(C1)
-----
      2
1 row selected.
```

## 17.18 BITAND

### Syntax

```
BITAND( num1, num2 )
```

### Description

It returns the AND operation result for the bits of num1 and num2.

The input argument data type can be NATIVE\_SMALLINT, NATIVE\_INTEGER, NATIVE\_BIGINT or a data type which can be converted to NATIVE\_BIGINT.

When converting to NATIVE\_BIGINT type, the decimal point is truncated.

If any of the input argument is NULL, the result is also NULL.

The result type is NATIVE\_BIGINT.

### Example

```
gSQL> SELECT BITAND( 5, 3 ) AS RESULT FROM DUAL;  
RESULT  
-----  
      1  
1 row selected.
```

## 17.19 BITNOT

### Syntax

```
BITNOT( num )
```

### Description

It returns the NOT operation result for the num bit.

The input argument data type can be `NATIVE_SMALLINT`, `NATIVE_INTEGER`, `NATIVE_BIGINT` or a data type which can be converted to `NATIVE_BIGINT`.

When converting to `NATIVE_BIGINT` type, the decimal point is truncated.

If the input argument is `NULL`, the result is also `NULL`.

The result type is as follows.

- If the input argument is `NATIVE_SMALLINT` type, its result type is `NATIVE_SMALLINT` type.
- If the input argument is `NATIVE_INTEGER` type, its result type is `NATIVE_INTEGER` type.
- If the input argument is `NATIVE_BIGINT` type, its result type is `NATIVE_BIGINT` type.

### Example

```
gSQL> SELECT BITNOT( 5 ) AS RESULT FROM DUAL;
```

```
RESULT
```

```
-----
```

```
      -6
```

```
1 row selected.
```



## 17.20 BITOR

### Syntax

```
BITOR( num1, num2 )
```

### Description

It returns the OR operation result for the bits of num1 and num2.

The input argument data type can be NATIVE\_SMALLINT, NATIVE\_INTEGER, NATIVE\_BIGINT types or a data type which can be converted to NATIVE\_BIGINT type.

When converting to NATIVE\_BIGINT type, the decimal point is truncated.

If any of the input argument value is NULL, the result is NULL.

The result type is NATIVE\_BIGINT type.

### Example

```
gSQL> SELECT BITOR( 5, 3 ) FROM DUAL;  
BITOR( 5, 3 )  
-----  
              7  
1 row selected.
```

## 17.21 BITXOR

### Syntax

```
BITXOR( num1, num2 )
```

### Description

It returns the XOR operation result for the bits of num1 and num2.

The input argument data type can be NATIVE\_SMALLINT, NATIVE\_INTEGER, NATIVE\_BIGINT or a data type which can be converted to NATIVE\_BIGINT.

When converting to NATIVE\_BIGINT type, the decimal point is truncated.

If any of the input argument value is NULL, the result is NULL.

The result type is NATIVE\_BIGINT.

### Example

```
gSQL> SELECT BITXOR( 5, 3 ) FROM DUAL;  
BITXOR( 5, 3 )  
-----  
                6  
1 row selected.
```

## 17.22 BIT\_LENGTH

### Syntax

```
BIT_LENGTH( str )
```

### Description

BIT\_LENGTH returns the number of bits for str.  
If str is NULL, then it returns NULL.

### Example

```
gSQL> SELECT BIT_LENGTH( 'LIKE' ) AS RESULT FROM DUAL;  
      RESULT  
-----  
          32  
1 row selected.
```

## 17.23 BYTE\_LENGTH

### Syntax

```
BYTE_LENGTH( str )
```

### Description

It is an alias of OCTET\_LENGTH.

For more information, refer to [OCTET\\_LENGTH](#), [LENGTHB](#).

### Example

- Multi byte character set (e.g. UTF8): 1 byte character

```
gSQL> SELECT BYTE_LENGTH( 'OCTET_LENGTH' ) AS RESULT_1BYTE_CHARACTERS
        FROM DUAL;
RESULT_1BYTE_CHARACTERS
-----
                        12
1 row selected.
```

- Multi byte character set (e.g. UTF8): 2 byte character

```
gSQL> SELECT BYTE_LENGTH( 'αβ' ) AS RESULT_2BYTE_CHARACTERS FROM DUAL;
RESULT_2BYTE_CHARACTERS
-----
                        4
1 row selected.
```

## 17.24 CASE2

### Syntax

```
CASE2( condition1, result1  
      [, condition2, result2  
      , ...  
      , conditionN, resultN ]  
      [, default ] )
```

### Description

CASE2 evaluates the condition in the described order.

If the comparison result is FALSE, it continues evaluating until TRUE comes up.

If the comparison result is TRUE, it returns the corresponding result, and does not evaluate any more.

If all the evaluation results are FALSE, it returns the default value. If the default is omitted, it returns NULL.

If multiple types are used in result, then the result type is determined according to **Result Type Combination Rule**.

CASE2 can be expressed by using CASE as follows.

- CASE2( condition1, res1, condition2, res2 )

```
CASE WHEN condition1 THEN res1  
      WHEN condition2 THEN res2  
      ELSE NULL  
END
```

- CASE2( condition1, res1, condition2, res2, default )

```
CASE WHEN condition1 THEN res1  
      WHEN condition2 THEN res2  
      ELSE default  
END
```

## Example

```
gSQL> SELECT I1,  
          CASE2( I1 = 1, 'ONE', I1 = 2, 'TWO' ) AS CASE2_RESULT1,  
          CASE2( I1 = 1, 'ONE', I1 = 2, 'TWO', 'NUMBER' ) AS CASE2_RESULT2  
FROM T1;  
I1 CASE2_RESULT1 CASE2_RESULT2  
-- -----  
1 ONE           ONE  
2 TWO           TWO  
3 null          NUMBER  
3 rows selected.
```

## 17.25 CBRT

### Syntax

```
CBRT( num )
```

### Description

It returns the cube root of num.

If num is NULL, the result is also NULL.

### Example

```
gSQL> SELECT CBRT( 27 ) FROM DUAL;
```

```
CBRT( 27 )
```

```
-----
```

```
3
```

```
1 row selected.
```

## 17.26 CEIL

### Syntax

```
CEIL( num )  
CEILING( num )
```

### Description

CEIL returns the smallest integer which is equal to or bigger than num.  
If num is NULL, then it returns NULL.

### Example

```
gSQL> SELECT CEIL( 3.5 ) AS RESULT1, CEIL( -3.5 ) AS RESULT2 FROM DUAL;  
RESULT1 RESULT2  
-----  
4      -3  
1 row selected.
```



## 17.27 CHAR\_LENGTH

### Syntax

```
CHAR_LENGTH( str )  
CHARACTER_LENGTH( str )
```

### Description

CHAR\_LENGTH returns the number of character for str according to the character set.

The str can be a character type such as CHARACTER, CHARACTER VARYING, CHARACTER LONG VARYING, or it can be a data type which can be converted to character type. The return type is NATIVE\_BIGINT.

If the data type of str is CHARACTER, the trailing blanks are included in the calculation.  
If str is NULL, it returns NULL.

It is an alias of LENGTH.

### Example

Multi byte character set: (e.g. UTF8)

```
gSQL> SELECT CHAR_LENGTH( 'αβ-SUMMER' ) AS RESULT FROM DUAL;  
  RESULT  
-----  
          9  
1 row selected.
```

## 17.28 CHR

### Syntax

```
CHR( num )
```

### Description

It returns a character in the database character set code corresponding to num.

num is a numeric type.

If num is NULL, then it returns NULL.

The return type is VARCHAR.

### Example

```
gSQL> SELECT CHR(71) FROM DUAL;  
CHR(71)  
-----  
G  
1 row selected.
```

## 17.29 CLOCK\_DATE

### Syntax

CLOCK\_DATE()

### Description

Whenever the CLOCK\_DATE function is called, the current date (DATE type) value is obtained.

The differences among the functions to obtain the current date are as follows.

- TRANSACTION\_DATE(): All date values in the transaction are same.
- STATEMENT\_DATE(): All date values in an SQL statement are same.
- CLOCK\_DATE(): Whenever the function is called, the current date value is obtained.

### Example

Each row can have a different date value.

```
gSQL> SELECT CLOCK_DATE() FROM t1;
CLOCK_DATE()
-----
2013-12-12
2013-12-12
2013-12-13
3 rows selected.
```

## 17.30 CLOCK\_LOCALTIME

### Syntax

```
CLOCK_LOCALTIME()
```

### Description

Whenever the `CLOCK_LOCALTIME` function is called, the current time value without TIME ZONE (TIME WITHOUT TIME ZONE type) is obtained.

The differences among the functions to obtain the current time are as follows.

- `TRANSACTION_LOCALTIME()`: All time values in the transaction are same.
- `STATEMENT_LOCALTIME()`: All time values in an SQL statement are same.
- `CLOCK_LOCALTIME()`: Whenever the function is called, the current time value is obtained.

### Example

Each row can have a different time value.

```
gSQL> SELECT CLOCK_LOCALTIME() FROM t1;
CLOCK_LOCALTIME()
-----
14:42:05.470757
14:42:05.470759
14:42:05.470759
3 rows selected.
```

## 17.31 CLOCK\_LOCALTIMESTAMP

### Syntax

CLOCK\_LOCALTIMESTAMP()

### Description

Whenever the CLOCK\_LOCALTIMESTAMP() function is called, the current TIMESTAMP value without TIME ZONE (TIMESTAMP WITHOUT TIME ZONE type) is obtained.

The differences among the functions to obtain the current TIMESTAMP are as follows.

- TRANSACTION\_LOCALTIMESTAMP(): All TIMESTAMP values in the transaction are same.
- STATEMENT\_LOCALTIMESTAMP(): All TIMESTAMP values in an SQL statement are same.
- CLOCK\_LOCALTIMESTAMP(): Whenever the function is called, the current timestamp value is obtained.

### Example

Each row can have a different timestamp value.

```
gSQL> SELECT CLOCK_LOCALTIMESTAMP() FROM t1;
CLOCK_LOCALTIMESTAMP()
-----
2013-12-12 14:46:17.309206
2013-12-12 14:46:17.309209
2013-12-12 14:46:17.309209
```

## 17.32 CLOCK\_TIME

### Syntax

```
CLOCK_TIME()
```

### Description

Whenever the `CLOCK_TIME()` function is called, the current time value with TIME ZONE (TIME WITH TIME ZONE type) is obtained.

The differences among the functions to obtain the current time are as follows.

- `TRANSACTION_TIME()`: All time values in the transaction are same.
- `STATEMENT_TIME()`: All time values in an SQL statement are same.
- `CLOCK_TIME()`: Whenever the function is called, the current time value is obtained.

### Example

Each row can have a different time value.

```
gSQL> SELECT CLOCK_TIME() FROM t1;
CLOCK_TIME()
-----
14:48:21.052324 +09:00
14:48:21.052326 +09:00
14:48:21.052327 +09:00
3 rows selected.
```

## 17.33 CLOCK\_TIMESTAMP

### Syntax

CLOCK\_TIMESTAMP()

### Description

Whenever CLOCK\_TIMESTAMP() function is called, the current TIMESTAMP value with TIME ZONE (TIMESTAMP WITH TIME ZONE type) is obtained.

The differences among the functions to obtain the current TIMESTAMP are as follows.

- TRANSACTION\_TIMESTAMP(): All TIMESTAMP values in the transaction are same.
- STATEMENT\_TIMESTAMP(): All TIMESTAMP values in an SQL statement are same.
- CLOCK\_TIMESTAMP(): Whenever the function is called, the current TIMESTAMP value is obtained.

### Example

Each row can have a different timestamp value.

```
gSQL> SELECT CLOCK_TIMESTAMP() FROM t1;
CLOCK_TIMESTAMP()
-----
2013-12-12 14:49:45.051709 +09:00
2013-12-12 14:49:45.051714 +09:00
2013-12-12 14:49:45.051714 +09:00
3 rows selected.
```

## 17.34 COALESCE

### Syntax

```
COALESCE( expr1, ..., exprN )
```

### Description

It returns the first non null expr in the expr list.

If all expr in the expr list are null, it returns null.

In the expr list, there should be two or more expr.

If multiple types are in the expr list, the result type is determined by the **Result Type Combination Rule**.

- COALESCE can be expressed by using CASE as follows.
  - COALESCE( expr1, expr2 )

```
CASE WHEN expr1 IS NOT NULL THEN expr1
      ELSE expr2
END
```

- COALESCE( expr1, expr2, ..., exprN )

```
CASE WHEN expr1 IS NOT NULL THEN expr1
      ELSE COALESCE( expr2, ..., exprN )
END
```

### Example

```
gSQL> SELECT COALESCE( NULL, 1, 2 ) FROM DUAL;
COALESCE( NULL, 1, 2 )
-----
                        1
1 row selected.
gSQL> SELECT COALESCE( NULL, NULL, NULL ) FROM DUAL;
```



COALESCE( NULL, NULL, NULL )

-----

null

1 row selected.

## 17.35 CONCAT

### Syntax

```
CONCAT( str1, str2, ... )
```

### Description

It is an alias of || ( CONCATENATE ).

It is an argument of CONCAT function and 2 ~ 254 number of CONCATs can be set.

For more information, refer to || (CONCATENATE), CONCATENATE.

### Example

```
gSQL> SELECT CONCAT( 'DATA', 'BASE' ) AS RESULT FROM DUAL;  
RESULT  
-----  
DATABASE  
1 row selected.
```

## 17.36 CONCATENATE

### Syntax

```
CONCATENATE( str1, str2, ... )
```

### Description

It is an alias of `||` ( `CONCATENATE` ).

It is an argument of `CONCATENATE` function and 2 ~ 254 number of `CONCATENATE`s can be set.

For more information, refer to `CONCAT, || (CONCATENATE)`.

### Example

```
gSQL> SELECT CONCATENATE( 'DATA', 'BASE' ) AS RESULT FROM DUAL;  
RESULT  
-----  
DATABASE  
1 row selected.
```

## 17.37 COS

### Syntax

```
COS(num)
```

### Description

It returns the COSINE value of num.

If the num argument is NULL, the result is also NULL.

### Example

```
gSQL> SELECT COS( 0 ) FROM DUAL;
```

```
COS( 0 )
```

```
-----
```

```
1
```

```
1 row selected.
```

## 17.38 COT

### Syntax

COT(num)

### Description

It returns the COTANGENT value of num.

If the num argument is NULL, the result is also NULL.

### Example

```
gSQL> SELECT COT( 1 ) FROM DUAL;  
          COT( 1 )  
-----  
.642092615934331  
1 row selected.
```

## 17.39 COUNT

### Syntax

```
COUNT( [ ALL | DISTINCT ] expr )
```

### Description

It is an aggregate function. It returns the number of row whose expr is not NULL.

If ALL is explicitly specified, aggregation is executed for all values.

If DISTINCT is explicitly specified, aggregation is executed for the values which exclude duplicate values.

If ALL or DISTINCT is not explicitly specified, it is processed in the same way as when ALL is specified.

### Example

```
gSQL> SELECT COUNT(c1) FROM t1;
COUNT(C1)
-----
          3
1 row selected.
```

## 17.40 COUNT(\*)

### Syntax

COUNT(\*)

### Description

It is an aggregate function, and the number of rows is obtained.

It has nothing to do with whether it is NULL or not because an expression is not explicitly specified.

### Example

```
gSQL> SELECT COUNT(*) FROM t1;
COUNT(*)
-----
         4
1 row selected.
```

## 17.41 CURRENT\_CATALOG

### Syntax

```
CURRENT_CATALOG [()]
```

### Description

The catalog name (database name) is obtained.

### Example

```
gSQL> SELECT CURRENT_CATALOG FROM dual;  
CURRENT_CATALOG  
-----  
TEST_DB  
1 row selected.
```



## 17.42 CURRENT\_DATE

### Syntax

```
CURRENT_DATE [(  
STATEMENT_DATE(  
))
```

### Description

The current date (DATE type) is obtained.

CURRENT\_DATE is an SQL standard function.

The differences among the functions to obtain the current date are as follows.

- TRANSACTION\_DATE(): All date values in the transaction are same.
- CURRENT\_DATE, STATEMENT\_DATE(): All date values in an SQL statement are same.
- CLOCK\_DATE(): Whenever the function is called, the current date value is obtained.

### Example

```
gSQL> SELECT CURRENT_DATE FROM t1;  
CURRENT_DATE  
-----  
2013-12-12  
2013-12-12  
2013-12-12  
3 rows selected.
```

## 17.43 CURRENT\_SCHEMA

### Syntax

```
CURRENT_SCHEMA [()]
```

### Description

User's current SCHEMA is obtained.

### Example

```
gSQL> SELECT CURRENT_SCHEMA FROM dual;  
CURRENT_SCHEMA  
-----  
PUBLIC  
1 row selected.
```

## 17.44 CURRENT\_TIME

### Syntax

```
CURRENT_TIME [( )]  
STATEMENT_TIME( )
```

### Description

The current TIME WITH TIME ZONE type value based on the session time is obtained.

CURRENT\_TIME is an SQL standard function.

The differences among the functions to obtain the current time are as follows.

- TRANSACTION\_TIME(): All time values in the transaction are same.
- CURRENT\_TIME, STATEMENT\_TIME(): All time values in an SQL statement are same.
- CLOCK\_TIME(): Whenever the function is called, the current time value is obtained.

### Example

All rows have the same value.

```
gSQL> SELECT CURRENT_TIME FROM t1;  
CURRENT_TIME  
-----  
16:27:10.116396 +09:00  
16:27:10.116396 +09:00  
16:27:10.116396 +09:00  
3 rows selected.
```

## 17.45 CURRENT\_TIMESTAMP

### Syntax

```
CURRENT_TIMESTAMP [()]  
STATEMENT_TIMESTAMP()
```

### Description

It obtains the `TIMESTAMP WITH TIME ZONE` type value based on the session time.

`CURRENT_TIMESTAMP` is an SQL standard function.

The differences among the functions to obtain the current `TIMESTAMP` are as follows.

- `TRANSACTION_TIMESTAMP()`: All `TIMESTAMP` values in the transaction are same.
- `CURRENT_TIMESTAMP`, `STATEMENT_TIMESTAMP()`: All `TIMESTAMP` values in an SQL statement are same.
- `CLOCK_TIMESTAMP()`: Whenever the function is called, the current timestamp value is obtained.

### Example

All rows have the same value.

```
gSQL> SELECT CURRENT_TIMESTAMP FROM t1;  
CURRENT_TIMESTAMP  
-----  
2013-12-12 16:34:55.649632 +09:00  
2013-12-12 16:34:55.649632 +09:00  
2013-12-12 16:34:55.649632 +09:00  
3 rows selected.
```

## 17.46 CURRENT\_USER

### Syntax

```
CURRENT_USER [()]
```

### Description

It returns the current user.

The user information is managed in three types as follows.

- Logon user: It is a user who performed login, and it is maintained until the connection is closed.
- Session user: It is as same as the first logon user, but it can be changed using the SET SESSION AUTHORIZATION statement.
- Current user: It is generally as same as the session user, but it is temporarily changed internally in system to control access when using the PSM, view.
  - The session user and current user is similar to the difference between the unix system's real user and the effective user.

### Example

```
% gsql sys gliese
gSQL> SET SESSION AUTHORIZATION test;
Session set.
gSQL> SELECT
        LOGON_USER() AS result1,
        SESSION_USER() AS result2,
        CURRENT_USER() AS result3
FROM DUAL;
RESULT1 RESULT2 RESULT3
-----
SYS     TEST     TEST
1 row selected.
```

## 17.47 CURRVAL

### Syntax

```
seq_name.CURRVAL  
CURRVAL(seq_name)
```

### Description

The current value of the sequence object is obtained.

A sequence value should be set with NEXTVAL(seq\_name) at least once.

### Example

```
gSQL> SELECT seq.CURRVAL FROM dual;  
SEQ.CURRVAL  
-----  
           1  
1 row selected.
```

## 17.48 DATEADD

### Syntax

```
DATEADD( datepart, number, date )
```

### Description

It adds number to the specified datepart of date, and returns the result.

If the number is decimal point, it is not rounded off.

The date data type can be DATE, TIMESTAMP, TIMESTAMP WITH TIME ZONE, TIME, TIME WITH TIME ZONE.

If number or date is NULL, the result is also NULL.

The result type which is as same as the input date argument type is returned.

**Table 17-11** Available string format in datepart

datepart	Description
YEAR	Year
QUARTER	Quarter
MONTH	Month
DAYOFYEAR	Day of year
DAY	Day
WEEK	Week
WEEKDAY	Weekday
HOUR	Hour
MINUTE	Minute
SECOND	Second
MILLISECOND	Millisecond
MICROSECOND	Microsecond

## Example

```
gSQL> SELECT
    DATEADD( YEAR, 1, TO_DATE( '2013-05-14', 'YYYY-MM-DD' ) ) AS RESULT
    FROM DUAL;
```

RESULT

-----

2014-05-14

1 row selected.

```
gSQL> SELECT
    DATEADD( MONTH, 13, TO_DATE('2013-05-14', 'YYYY-MM-DD') ) AS RESULT
    FROM DUAL;
```

RESULT

-----

2014-06-14

1 row selected.

```
gSQL> SELECT
    DATEADD( DAY, 397, TO_DATE('2013-05-14', 'YYYY-MM-DD') ) AS RESULT
    FROM DUAL;
```

RESULT

-----

2014-06-15

1 row selected.



## 17.49 DATEDIFF

### Syntax

```
DATEDIFF( datepart, startdate, enddate )
```

### Description

It subtracts startdate from enddate, then returns the result to the specified datepart.

If the startdate or enddate is NULL, the result is also NULL.

The data type of startdate and enddate can be DATE, TIMESTAMP, TIMESTAMP WITH TIME ZONE, TIME.

The result type is NUMBER.

**Table 17-12** Available string format in datepart

datepart	Description
YEAR	Year
QUARTER	Quarter
MONTH	Month
DAYOFYEAR	Day of year
DAY	Day
HOUR	Hour
MINUTE	Minute
SECOND	Second
MILLISECOND	Millisecond
MICROSECOND	Microsecond

### Example

```
gSQL> SELECT
    DATEDIFF( YEAR,
              TO_DATE( '2013-05-14', 'YYYY-MM-DD' ),
              TO_DATE( '2014-06-15', 'YYYY-MM-DD' ) ) AS RESULT
FROM DUAL;
```

```
RESULT
```

```
-----
```

```
1
```

```
1 row selected.
```

```
gSQL> SELECT
```

```
    DATEDIFF( MONTH,  
             TO_DATE( '2013-05-14', 'YYYY-MM-DD' ),  
             TO_DATE( '2014-06-15', 'YYYY-MM-DD' ) ) AS RESULT  
FROM DUAL;
```

```
RESULT
```

```
-----
```

```
13
```

```
1 row selected.
```

```
gSQL> SELECT
```

```
    DATEDIFF( DAY,  
             TO_DATE( '2013-05-14', 'YYYY-MM-DD' ),  
             TO_DATE( '2014-06-15', 'YYYY-MM-DD' ) ) AS RESULT  
FROM DUAL;
```

```
RESULT
```

```
-----
```

```
397
```

```
1 row selected.
```

## 17.50 DATE\_ADD

### Syntax

```
DATE_ADD( date, INTERVAL expr unit )
```

### Description

It is the same function as **ADDDATE** (date, INTERVAL expr unit).

### Example

```
gSQL> SELECT
      DATE_ADD( TO_DATE( '2012-01-02', 'YYYY-MM-DD' ),
                INTERVAL '2-2' YEAR TO MONTH ) AS RESULT
      FROM DUAL;
RESULT
-----
2014-03-02
1 row selected.
```

## 17.51 DATE\_PART

### Syntax

```
DATE_PART( field, datetime )
```

### Description

The result of DATE\_PART is as same as the result of the EXTRACT function. It searches for the specified field from the input datetime type, and returns it.

The field argument should be text literal, and YEAR, MONTH, DAY, HOUR, MINUTE, SECOND, TIMEZONE\_HOUR, TIMEZONE\_MINUTE can be specified to text literal.

The datetime argument data type can be DATE, TIMESTAMP, TIMESTAMP WITH TIME ZONE, TIME, TIME WITH TIME ZONE, INTERVAL.

If field is not in the range of datetime, an error is returned.

For DATE type, field should be YEAR, MONTH, DAY, otherwise an error is returned.

If datetime is NULL, then it returns NULL.

The return type is NUMBER.

For more information, refer to [EXTRACT](#).

### Example

```
gSQL> SELECT
    DATE_PART( 'DAY', TO_DATE( '2012-01-02', 'YYYY-MM-DD' ) ) AS RESULT
FROM DUAL;
RESULT
-----
      2
1 row selected.
gSQL> SELECT
    DATE_PART( 'YEAR', INTERVAL '9-11' YEAR TO MONTH ) AS RESULT
FROM DUAL;
```

RESULT

-----

9

1 row selected.

## 17.52 DECODE

### Syntax

```
DECODE( expr, comparison_expr1, result1
      [, comparison_expr2, result2
      , ...
      , comparison_exprN, resultN ]
      [, default ] )
```

### Description

It evaluates `expr` and `comparison_expr` in the described order in `DECODE` statement using equal operation.

If the comparison result is `FALSE`, it continues evaluating until `TRUE` comes up.

If the comparison result is `TRUE`, it returns the corresponding result, and does not evaluate any more.

If `expr` and `comparison_expr` are equal, or if both `expr` and `comparison_expr` are `NULL` ( `null = null` ), it is evaluated as `TRUE`, and returns the corresponding result.

If all of the evaluated results are `FALSE`, it returns `default`. If the `default` is omitted, it returns `NULL`.

- Comparing `expr` and `comparison_expr`

All `expr`, `comparison_expr1`, ..., `comparison_exprN` are converted to the data type of `comparison_expr1` (the first `comparison_expr`), then they are compared.

If `comparison_expr1` (the first `comparison_expr`) is a character type and a numeric type then it becomes the type including the range of types described in each `expr`, `comparison_expr1`, ..., `comparison_exprN`.

If all types described in `expr`, `comparison_expr1`, ..., `comparison_exprN` are `CHAR`, then `VARCHAR` type comparison is performed.

- Result type

The result type becomes the data type of `result1` (the first result).

If the data type of `result1` (the first result) is a character type and a numeric type then it becomes the type including the range of types described in `result1`, ..., `resultN` each.

If `result1` (the first result) is `CHAR` or `NULL`, then the result type is `VARCHAR`.

`DECODE` can be expressed by using `CASE` as follows.

- `DECODE( expr, comp_expr1, res1, comp_expr2, res2 )`

```

CASE WHEN (expr = comp_expr1) OR (expr IS NULL AND comp_expr1 IS NULL ) THEN res1
      WHEN (expr = comp_expr2) OR (expr IS NULL AND comp_expr2 IS NULL ) THEN res2
      ELSE NULL
END

```

- DECODE( expr, comp\_expr1, res1, comp\_expr2, res2, default )

```

CASE WHEN (expr = comp_expr1) OR (expr IS NULL AND comp_expr1 IS NULL ) THEN res1
      WHEN (expr = comp_expr2) OR (expr IS NULL AND comp_expr2 IS NULL ) THEN res2
      ELSE default
END

```

## Example

```

gSQL> SELECT I1,
           DECODE( I1, 1, 'ONE',
                  2, 'TWO',
                  NULL, 'NULL VALUE',
                  'DEFAULT VALUE' ) AS DECODE_RESULT
FROM T1;
I1 DECODE_RESULT
-----
1 ONE
2 TWO
null NULL VALUE
3 DEFAULT VALUE
4 rows selected.

```

## 17.53 DEGREES

### Syntax

```
DEGREES( radians )
```

### Description

It converts a degree radians to a value in degrees, and returns the converted value. If radians is NULL, then it returns NULL.

### Example

```
gSQL> SELECT DEGREES( PI() ) AS RESULT FROM DUAL;  
RESULT  
-----  
      180  
1 row selected.
```



## 17.54 DIGEST

### Syntax

```
DIGEST( data, type )
```

### Description

It hashes the data to the given type, and returns the result in VARBINARY type.

An implicit conversion may occur when inputting data type based on the following rules.

- Input the BINARY, VARBINARY type data in VARBINARY type.
- Input LONG VARBINARY type data in LONG VARBINARY type.
- Input LONG VARCHAR type data in LONG VARCHAR type.
- Input all other type of data after implicitly converting it to VARCHAR type.

DIGEST function supports the following hash types.

- The result of 'SHA1' is 20 byte varbinary.
- The result of 'SHA224' is 28 byte varbinary.
- The result of 'SHA256' is 32 byte varbinary.
- The result of 'SHA384' is 48 byte varbinary.
- The result of 'SHA512' is 64 byte varbinary.

Use HEX function to view the result in hexadecimal character because the result is returned in VARBINARY type. In this case, the length becomes double of the original.

### Example

```
gSQL> SELECT HEX( DIGEST( 'my password', 'SHA256' ) ) AS RESULT FROM DUAL;  
RESULT  
-----  
BB14292D91C6D0920A5536BB41F3A50F66351B7B9D94C804DFCE8A96CA1051F2  
1 row selected.
```

## 17.55 DUMP

### Syntax

DUMP( expr )

### Description

It returns internal representation information of expr.

Internal representation information is displayed as the data type, byte length and data information.

expr can be any data types.

If expr is NULL, then it returns NULL.

The return type is CHARACTER VARYING.

### Example

```
gSQL> SELECT DUMP( 'DUMP' ) AS RESULT FROM DUAL;
```

```
RESULT
```

```
-----
```

```
Type=CHAR Len=4 : Str=68,85,77,80
```

```
1 row selected.
```

## 17.56 EXP

### Syntax

EXP( num )

### Description

It returns squared value of e (base of natural logarithm)'s num.  
If num is NULL, then it returns NULL.

### Example

```
gSQL> SELECT EXP( 1 ) AS RESULT FROM DUAL;  
          RESULT  
-----  
2.71828182845905  
1 row selected.
```

## 17.57 EXTRACT

### Syntax

```
EXTRACT( <field> FROM datetime )
<field> ::=
    YEAR
    | MONTH
    | DAY
    | HOUR
    | MINUTE
    | SECOND
    | TIMEZONE_HOUR
    | TIMEZONE_MINUTE
```

### Description

It searches for the specified field from an input datetime type, and returns it.

The datetime argument data type can be DATE, TIMESTAMP, TIMESTAMP WITH TIME ZONE, TIME, TIME WITH TIME ZONE, INTERVAL.

If field is not in the range of datetime, an error is returned.

For DATE type, the field should be YEAR, MONTH, DAY, otherwise an error is returned.

The return type is NUMBER.

Result of EXTRACT is as same as the result of the **DATE\_PART** function.

### Example

```
gSQL> SELECT
    EXTRACT( SECOND FROM TO_TIMESTAMP( '2012-12-13 01:23:44.5',
                                        'YYYY-MM-DD HH24:MI:SS.FF1' ) )
    AS RESULT
FROM DUAL;
RESULT
```

```
-----
```

```
44.5
```

```
1 row selected.
```

```
gSQL> SELECT
```

```
    EXTRACT( YEAR FROM CAST('2-3' AS INTERVAL YEAR TO MONTH) ) AS RESULT
```

```
    FROM DUAL;
```

```
RESULT
```

```
-----
```

```
2
```

```
1 row selected.
```

## 17.58 FACTORIAL

### Syntax

```
FACTORIAL( num )
```

### Description

It multiplies the successive natural numbers from 1 to num in order, and returns the result. If num is NULL, then it returns NULL.

### Example

```
gSQL> SELECT FACTORIAL( 5 ) AS RESULT FROM DUAL;  
RESULT  
-----  
      120  
1 row selected.
```

## 17.59 FLOOR

### Syntax

```
FLOOR( num )
```

### Description

It returns the biggest integer which is equal to or smaller than num.  
If num is NULL, then it returns NULL.

### Example

```
gSQL> SELECT FLOOR(42.8) AS RESULT1, FLOOR(-42.8) AS RESULT2 FROM DUAL;  
RESULT1 RESULT2  
-----  
42      -43  
1 row selected.
```





## 17.61 FROM\_TZ

### Syntax

```
FROM_TZ( timestamp, timezone )
```

### Description

FROM\_TZ function converts the timestamp and the timezone in the specified format to TIMESTAMP WITH TIME ZONE type, then returns it.

The timestamp argument should be TIMESTAMP type or the type convertible to TIMESTAMP type. If the timestamp argument is NULL, then the result value is also NULL.

The timezone argument should be CHARACTER type such as CHARACTER and CHARACTER VARYING, and the format is 'TZH:TZM'.

If the timezone argument is NULL, then the result is also NULL.

The result type is TIMESTAMP(6) WITH TIME ZONE.

### Example

```
gSQL> SELECT
      FROM_TZ( TIMESTAMP'2021-01-01 10:10:20.000000', '+06:00' ) AS RESULT
      FROM DUAL;
RESULT
-----
2021-01-01 10:10:20.000000 +06:00
1 row selected.
```

## 17.62 GREATEST

### Syntax

```
GREATEST( expr1 [ , expr2, ... exprn ] )
```

### Description

It returns the largest value among the received expr argument.

If any expr argument is NULL, the result value is NULL.

The result type becomes the data type of expr1 (the first expr).

If the data type of expr1 (the first expr) is a character type and a numeric type then it becomes the type including the range of expr1, ..., exprN each.

If all of expr1, ..., exprN is described in CHAR type, then all exprs are compared in VARCHAR type and the result type is VARCHAR.

### Example

```
gSQL> SELECT GREATEST( 100, 0, 200, 150, 1 ) AS RESULT FROM DUAL;  
RESULT  
-----  
      200  
1 row selected.
```

## 17.63 HEX

### Syntax

```
HEX( str )
```

### Description

It returns a str argument in hexadecimal character.

A str argument data type can be a character type such as CHARACTER, CHARACTER VARYING, CHARACTER LONG VARYING, a type which can be converted to a character type, or a binary character type such as BINARY, BINARY VARYING, BINARY LONG VARYING.

The result type is a character type such as CHARACTER VARYING or CHARACTER LONG VARYING.

If str is NULL, then the result value is also NULL.

If an argument of HEX function is a numeric type, then it returns an error.

To convert a decimal number to a hexadecimal number, use TO\_CHAR() function by using 'X' number format.

e.g. TO\_CHAR( 255, 'XX' )

For more information, refer to **UNHEX**.

### Example

```
gSQL> SELECT HEX( 'abc' ) FROM DUAL;  
HEX( 'abc' )  
-----  
616263  
1 row selected.
```

## 17.64 INITCAP

### Syntax

```
INITCAP( str )
```

### Description

It converts the first letter in each word of string `str` into uppercase, and converts all other letters into lowercase, then it returns the result.

`str` data type can be a character type such as CHARACTER, CHARACTER VARYING, CHARACTER LONG VARYING.

Each word in string is classified by white space or characters which are not alphanumeric. If `str` is NULL, the result is also NULL.

The return type is as same as `str` argument datatype.

### Example

```
gSQL> SELECT INITCAP( 'hi GLIESE' ) AS RESULT FROM DUAL;  
RESULT  
-----  
Hi Gliese  
1 row selected.
```

## 17.65 INSTR

### Syntax

```
INSTR( str, substr [, position [, occurrence ] ] )
```

### Description

It search for occurrence<sup>th</sup> substr starting from str's position, and returns its location.

The data types of str arguments and substr arguments can be a character type such as CHARACTER, CHARACTER VARYING, CHARACTER LONG VARYING, or a binary character type such as BINARY, BINARY VARYING, BINARY LONG VARYING.

The position argument and occurrence argument can be numeric data type.

If position and occurrence are omitted, the default is 1.

The position and occurrence start from 1, and they are calculated in character unit according to character set (not in byte unit).

The position means the first position to search substr in str, it should not be zero, but an integer value.

- If the position is positive: It compares forwards (toward the right) from the beginning of str until it finds the position of substr.
- If the position is negative: It compares backwards (toward the left) from the end of str it finds the position of substr.
- If the position is 0: The result is 0.

The occurrence means the number of repeating the subtr in the str, and it should be a positive integer.

If any of the input argument is NULL, the result is also NULL.

### Example

```
gSQL> SELECT INSTR( 'ABCD ABCD ABCDABCD', 'BC' ) AS RESULT1,  
              INSTR( 'ABCD ABCD ABCDABCD', 'BC', 4 ) AS RESULT2  
FROM DUAL;
```

```
RESULT1 RESULT2
```

```
-----
```

```
2      7
```

```
1 row selected.
```

```
gSQL> SELECT INSTR( 'ABCD ABCD ABCDABCD', 'BC', 5 , 3 ) AS RESULT1,  
           INSTR( 'ABCD ABCD ABCDABCD', 'BC', -5, 3 ) AS RESULT2  
           FROM DUAL;
```

```
RESULT1 RESULT2
```

```
-----
```

```
16     2
```

```
1 row selected.
```

## 17.66 LAST\_DAY

### Syntax

```
LAST_DAY( date )
```

### Description

It returns the last day of the month which is included in date.

The date argument data type can be DATE, TIMESTAMP, TIMESTAMP WITH TIME ZONE.  
The return type is always DATE regardless of the date argument data type.

If date is NULL, then it returns NULL.

### Example

```
gSQL> SELECT
      LAST_DAY( TO_DATE( '2012-07-10', 'YYYY-MM-DD' ) ) AS RESULT FROM DUAL;
RESULT
-----
2012-07-31
1 row selected.
```

## 17.67 LAST\_IDENTITY\_VALUE

### Syntax

```
LAST_IDENTITY_VALUE()
```

### Description

It is the recent value automatically created for an identity column in the current session, and the result type is NATIVE\_BIGINT.

If there is not an automatically created value, then it returns null.

This function is similar to @@IDENTITY of MS-SQL and LAST\_INSERT\_ID() of MySQL. Be cautious when using it because the last altered table determines the value when performing DML for multiple tables as follows.

```
gSQL> INSERT INTO t1(name) VALUES ( 'leekmo' );
1 row created.
gSQL> SELECT LAST_IDENTITY_VALUE() FROM dual;
LAST_IDENTITY_VALUE()
-----
12
1 row selected.
gSQL> INSERT INTO t2(name) VALUES ( 'leekmo' );
1 row created.
gSQL> SELECT LAST_IDENTITY_VALUE() FROM dual;
LAST_IDENTITY_VALUE()
-----
2
1 row selected.
```

To obtain an identity column value created when performing the INSERT, use **INSERT INTO name RETURNING .. INTO** statement as follows.

```
gSQL> CREATE TABLE t1 ( id INTEGER GENERATED BY DEFAULT AS IDENTITY, name VARCHAR(32) );
Table created.
gSQL> \var v1 integer
```



```
gSQL> INSERT INTO t1(name) VALUES ( 'leekmo' ) RETURN id INTO :v1;
V1
--
1
1 row created.
```

## Example

The following is an example of using LAST\_IDENTITY\_VALUE() function.

```
gSQL> CREATE TABLE t1 ( id INTEGER GENERATED BY DEFAULT AS IDENTITY,
                        name VARCHAR(32) );
Table created.
gSQL> COMMIT;
Commit complete.
```

- There is not an identity value created in the current session.

```
gSQL> SELECT LAST_IDENTITY_VALUE() FROM dual;
LAST_IDENTITY_VALUE()
-----
                        null
1 row selected.
```

- Identity value (1) is automatically created.

```
gSQL> INSERT INTO t1(name) VALUES ( 'leekmo' );
1 row created.
```

- Result: 1

```
gSQL> SELECT LAST_IDENTITY_VALUE() FROM dual;
LAST_IDENTITY_VALUE()
-----
                        1
1 row selected.
```

- Identity value (2) is automatically created as a default value.

```
gSQL> UPDATE t1 SET id = DEFAULT;  
1 row updated.
```

- Result: 2

```
gSQL> SELECT LAST_IDENTITY_VALUE() FROM dual;  
LAST_IDENTITY_VALUE()  
-----  
2  
1 row selected.
```

- The user input value does not automatically create an identity value.

```
INSERT INTO t1 VALUES ( 100, 'jhkim' );  
1 row updated.
```

- Result: 2

```
SELECT LAST_IDENTITY_VALUE() FROM dual;  
LAST_IDENTITY_VALUE()  
-----  
2  
1 row selected.
```

## 17.68 LEAST

### Syntax

```
LEAST( expr1 [, expr2, ... exprn ] )
```

### Description

It returns the smallest value among received expr arguments.

If any of expr is NULL, the result is NULL.

The result type is determined according to the data type of expr1 (the first expr).

If the data type of expr1 (the first expr) is a character type and a numeric type then it becomes the type including the range of expr1, ..., exprN each.

If all of expr1, ..., exprN is described in CHAR type, then all exprs are compared in VARCHAR type and the result type is VARCHAR.

### Example

```
gSQL> SELECT LEAST( 100, 0, 200, 150, 1 ) AS RESULT FROM DUAL;  
RESULT  
-----  
          0  
1 row selected.
```

## 17.69 LENGTH

### Syntax

```
LENGTH( str )
```

### Description

It is an alias of `CHAR_LENGTH`.

### Example

Multi byte character set: (e.g.UTF8)

```
gSQL> SELECT LENGTH( 'αβ-SUMMER' ) AS RESULT FROM DUAL;  
      RESULT  
-----  
              9  
1 row selected.
```

## 17.70 LENGTHB

### Syntax

```
LENGTHB( str )
```

### Description

It is an alias of `OCTET_LENGTH`.

For more information, refer to `BYTE_LENGTH`.

### Example

- Multi byte character set (e.g.UTF8): 1 byte character

```
gSQL> SELECT LENGTHB( 'OCTET_LENGTH' ) AS RESULT_1BYTE_CHARACTERS
        FROM DUAL;
RESULT_1BYTE_CHARACTERS
-----
                        12
1 row selected.
```

- Multi byte character set (e.g.UTF8): 2 byte character

```
gSQL> SELECT LENGTHB( 'αβ' ) AS RESULT_2BYTE_CHARACTERS FROM DUAL;
RESULT_2BYTE_CHARACTERS
-----
                        4
1 row selected.
```

## 17.71 LN

### Syntax

```
LN( num )
```

### Description

It returns the natural logarithm value of num.  
num should be a value which is bigger than 0.  
If num is NULL, then it returns NULL.

### Example

```
gSQL> SELECT LN( 2.71828182845905 ) AS RESULT FROM DUAL;  
RESULT  
-----  
1  
1 row selected.
```

## 17.72 LNNVL

### Syntax

```
LNNVL( expr )
```

### Description

Logical Not Null VaLue (LNNVL) function is similar to NOT logical operator, but the difference is that it returns TRUE as in the following example when the input value is null.

### Example

```
gSQL> SELECT c1, c2, (c1 = c2), NOT(c1 = c2), LNNVL(c1 = c2) FROM t1;
```

```
C1   C2 (C1 = C2) NOT(C1 = C2) LNNVL(C1 = C2)
```

```
-----  
1    1 TRUE      FALSE      FALSE  
1    2 FALSE     TRUE       TRUE  
1 null null     null       TRUE
```

```
3 rows selected.
```

## 17.73 LOCALTIME

### Syntax

```
LOCALTIME [()]  
STATEMENT_LOCALTIME()
```

### Description

The current TIME WITHOUT TIME ZONE type value based on the session time is obtained.

LOCALTIME is an SQL standard function.

The differences among the functions to obtain the current time are as follows.

- TRANSACTION\_LOCALTIME(): All time values in the transaction are same.
- LOCALTIME, STATEMENT\_LOCALTIME(): All time values in an SQL statement are same.
- CLOCK\_LOCALTIME(): Whenever the function is called, the current time value is obtained.

### Example

All rows have the same value.

```
gSQL> SELECT LOCALTIME FROM t1;  
LOCALTIME  
-----  
16:17:08.592459  
16:17:08.592459  
16:17:08.592459  
3 rows selected.
```



## 17.74 LOCALTIMESTAMP

### Syntax

```
LOCALTIMESTAMP [( )]  
STATEMENT_LOCALTIMESTAMP()
```

### Description

The current `TIMESTAMP WITHOUT TIME ZONE` type value based on the session time is obtained.

`LOCALTIMESTAMP` is an SQL standard function.

The differences among the functions to obtain the current `TIMESTAMP` are as follows.

- `TRANSACTION_LOCALTIMESTAMP()`: All `TIMESTAMP` values in the transaction are same.
- `LOCALTIMESTAMP`, `STATEMENT_LOCALTIMESTAMP()`: All `TIMESTAMP` values in an SQL statement are same.
- `CLOCK_LOCALTIMESTAMP()`: Whenever the function is called, the current timestamp value is obtained.

### Example

All rows have the same value.

```
gSQL> SELECT LOCALTIMESTAMP FROM t1;  
LOCALTIMESTAMP  
-----  
2013-12-12 16:21:51.790614  
2013-12-12 16:21:51.790614  
2013-12-12 16:21:51.790614  
3 rows selected.
```

## 17.75 LOCAL\_GROUP\_ID

### Syntax

`LOCAL_GROUP_ID()`

### Description

It returns a cluster group ID for a server which processes a query from a user.



It is a valid information in a cluster system.

### Example

All rows have the same value.

```
gSQL> SELECT LOCAL_GROUP_ID() FROM DUAL;  
LOCAL_GROUP_ID()  
-----  
1  
1 row selected.
```

## 17.76 LOCAL\_GROUP\_NAME

### Syntax

LOCAL\_GROUP\_NAME()

### Description

It returns a cluster group name for a server which processes a query from a user.



It is a valid information in a cluster system.

### Example

All rows have the same value.

```
gSQL> SELECT LOCAL_GROUP_NAME() FROM DUAL;  
LOCAL_GROUP_NAME()  
-----  
G1  
1 row selected.
```

## 17.77 LOCAL\_MEMBER\_ID

### Syntax

`LOCAL_MEMBER_ID()`

### Description

It returns a cluster member ID for a server which processes a query from a user.



It is a valid information in a cluster system.

### Example

All rows have the same value.

```
gSQL> SELECT LOCAL_MEMBER_ID() FROM DUAL;  
LOCAL_MEMBER_ID()  
-----  
1  
1 row selected.
```

## 17.78 LOCAL\_MEMBER\_NAME

### Syntax

`LOCAL_MEMBER_NAME()`

### Description

It returns a cluster member name for a server which processes a query from a user.



It is a valid information in a cluster system.

### Example

All rows have the same value.

```
gSQL> SELECT LOCAL_MEMBER_NAME() FROM DUAL;
```

```
LOCAL_MEMBER_NAME()  
-----
```

```
G1N1
```

```
1 row selected.
```

## 17.79 LOG

### Syntax

```
LOG( num2 )  
LOG( num1, num2 )
```

### Description

It returns the logarithm of num2 in the num1 base.

If num1 is omitted, it returns the logarithm value whose base is 10.

num1 should be a positive number except 1 and 0, and num2 should be a positive number.

If num1 or num2 is NULL, then it returns NULL.

### Example

```
gSQL> SELECT LOG( 100 ) AS RESULT1, LOG( 4, 16 ) AS RESULT2 FROM DUAL;  
RESULT1 RESULT2  
-----  
2        2  
1 row selected.
```

## 17.80 LOGON\_USER

### Syntax

LOGON\_USER()

### Description

It returns the logged-in user.

The user information is managed in three types as follows.

- Logon user: It is a user who performed login, and it is maintained until the connection is closed.
- Session user: It is as same as the first logon user, but it can be changed using the SET SESSION AUTHORIZATION statement.
- Current user: It is generally as same as the session user, but it is temporarily changed internally in system to control access when using the PSM, view.
  - The session user and current user is similar to the difference between the unix system's real user and the effective user.

### Example

```
% gsql test test
gSQL> SELECT LOGON_USER() AS result FROM DUAL;
RESULT
-----
TEST
1 row selected.
```

## 17.81 LOWER

### Syntax

```
LOWER( str )
```

### Description

It returns lowercases of str.

The str argument data type can be a character type such as CHARACTER, CHARACTER VARYING, CHARACTER LONG VARYING.

If str is NULL, the result is also NULL.

The return type is the same datatype as the str argument.

### Example

```
gSQL> SELECT LOWER( 'SPRING' ) AS RESULT FROM DUAL;  
RESULT  
-----  
spring  
1 row selected.
```



## 17.82 LPAD

### Syntax

```
LPAD( str, length, [, fill] )
```

### Description

It adds character string fill to the left side of str until the string length becomes length, then returns the result.

The str argument data type can be character type such as CHARACTER, CHARACTER VARYING, CHARACTER LONG VARYING, and a binary character type such as BINARY, BINARY VARYING, BINARY LONG VARYING.

The length argument is numeric type.

length means the number of characters, and its maximum range is the maximum precision of the result type.

If fill is omitted, a white space is added.

If str is longer than the length, it cuts the str as long as the length, then returns it.

If any of str, length, fill is NULL, the result is also NULL.

If length is 0 or a negative number, the result is NULL.

The following table describes the result types.

**Table 17-13** Result type of LPAD

str type	Result type
CHAR or VARCHAR	VARCHAR
LONG VARCHAR	LONG VARCHAR
BINARY or VARBINARY	VARBINARY
LONG VARBINARY	LONG VARBINARY

## Example

```
gSQL> SELECT LPAD('AA', 5) AS RESULT1,  
             LPAD('AA', 5, 'X' ) AS RESULT2,  
             LPAD('AA', 1 ) AS RESULT3  
        FROM DUAL;  
RESULT1 RESULT2 RESULT3  
-----  
AA  XXXAA  A  
1 row selected.
```

## 17.83 LTRIM

### Syntax

```
LTRIM( trim_source [, trim_character ] )
```

### Description

It removes the matching characters by comparing from the left side of trim\_character in trim\_source until the matching character does not exist. Then it returns the result.

The data type of trim\_character argument and trim\_source argument can be a character type such as CHARACTER, CHARACTER VARYING, CHARACTER LONG VARYING, and a binary character type such as BINARY, BINARY VARYING, BINARY LONG VARYING.

If any of trim\_character, trim\_source is NULL, the result is NULL.

If trim\_character is omitted, a single blank space ( ' ' ) is specified by default.

The following table describes the result types.

**Table 17-14** Result type of LTRIM

trim_source, trim_character type	Result type
CHAR or VARCHAR	VARCHAR
LONG VARCHAR	LONG VARCHAR
BINARY or VARBINARY	VARBINARY
LONG VARBINARY	LONG VARBINARY

### Example

```
gSQL> SELECT LTRIM( '____LTRIM', '_' ) AS RESULT FROM DUAL;
RESULT
-----
LTRIM
1 row selected.
```

## 17.84 MAX

### Syntax

```
MAX( [ ALL | DISTINCT ] expr )
```

### Description

It is an aggregate function and the maximum value among rows' exprs is obtained.

If ALL is explicitly specified, aggregation is executed for all values.

If DISTINCT is explicitly specified, aggregation is executed for the values which exclude duplicate values.

If ALL or DISTINCT is not explicitly specified, it is processed in the same way as when ALL is specified.

MAX function returns the same result without being affected by the ALL and DISTINCT.

### Example

```
gSQL> SELECT MAX(c1) FROM t1;
MAX(C1)
-----
      3
1 row selected.
```

## 17.85 MIN

### Syntax

```
MIN( [ ALL | DISTINCT ] expr )
```

### Description

It is an aggregate function and the minimum value among rows' exprs is obtained.

If ALL is explicitly specified, aggregation is executed for all values.

If DISTINCT is explicitly specified, aggregation is executed for the values which exclude duplicate values.

If ALL or DISTINCT is not explicitly specified, it is processed in the same way as when ALL is specified.

MIN function returns the same result without being affected by the ALL and DISTINCT.

### Example

```
gSQL> SELECT MIN(c1) FROM t1;
MIN(C1)
-----
      1
1 row selected.
```

## 17.86 MOD

### Syntax

```
MOD( num1, num2 )
```

### Description

It divides num1 by num2, and returns the remainder.

The num1 argument and num2 argument can be a numeric data type.

If num2 is 0, an error is returned.

If the num1 argument or num2 argument is NULL, then NULL is returned.

### Example

```
gSQL> SELECT MOD(5, 4) AS RESULT1, MOD(-5, 4) AS RESULT2 FROM DUAL;  
RESULT1 RESULT2  
-----  
1      -1  
1 row selected.
```

## 17.87 MONTHS\_BETWEEN

### Syntax

```
MONTHS_BETWEEN( date1, date2 )
```

### Description

MONTHS\_BETWEEN returns the number of months of which days between date2 and date1 are divided by 31.

If date1 or date2 is NULL, then the result is also NULL.

The date1 argument and date2 argument can be DATE, TIMESTAMP, TIMESTAMP WITH TIME ZONE type.

The result type is NUMBER.



If the same date (e.g. 2014-01-15 and 2014-02-15), or the last day of the month (e.g. 2014-08-31 and 2014-09-30) is included both in date1 and date2, then it returns the integer result regardless of the agreement of timestamp section (if it exists).

### Example

```
gSQL> SELECT
      MONTHS_BETWEEN('2018-01-18', '2018-01-17')
FROM DUAL;
MONTHS_BETWEEN('2018-01-18', '2018-01-17')
-----
                        3.225806451612903E-2
```

1 row selected.

```
gSQL> SELECT
      MONTHS_BETWEEN('2018-02-17', '2018-01-17')
FROM DUAL;
MONTHS_BETWEEN('2018-02-17', '2018-01-17')
-----
```

1

1 row selected.

```
gSQL> SELECT
```

```
    MONTHS_BETWEEN('2018-02-28', '2018-01-31')
```

```
FROM DUAL;
```

```
MONTHS_BETWEEN('2018-02-28', '2018-01-31')
```

-----

1

1 row selected.



## 17.88 NEXT\_DAY

### Syntax

```
NEXT_DAY( date, day )
```

### Description

It obtains a date of the day (day of week) which comes first after the given date (an argument).

The second day argument can be a string or a number which indicates the day.

- String: SUNDAY ~ SATURDAY or SUN ~ SAT
- Number: 1 (sunday) ~ 7 (saturday)

If any of the input argument is NULL, the result is also NULL.

The return type is always DATE regardless of the input type of the date.

The hour, minute and second of the result value returns the same hour, minute and second of the input argument date.

### Example

- 2020-08-11 is Tuesday.

```
gSQL> SELECT NEXT_DAY( TO_DATE( '2020-08-11', 'YYYY-MM-DD' ),
                        'SUNDAY' ) AS RESULT1
      FROM DUAL;
RESULT1
-----
2020-08-16
1 row selected.
gSQL> SELECT NEXT_DAY( TO_DATE( '2020-08-11', 'YYYY-MM-DD' ),
                        'SUN' ) AS RESULT1
      FROM DUAL;
RESULT1
-----
2020-08-16
```

1 row selected.

```
gSQL> SELECT NEXT_DAY( TO_DATE( '2020-08-11', 'YYYY-MM-DD' ),  
                      1 ) AS RESULT1
```

```
FROM DUAL;
```

```
RESULT1
```

```
-----
```

```
2020-08-16
```

1 row selected.

```
gSQL> SELECT TO_CHAR( NEXT_DAY( TO_DATE( '2020-08-11', 'YYYY-MM-DD' ),  
                              'SUNDAY' ),
```

```
                      'YYYY-MM-DD HH24:MI:SS' ) AS RESULT1
```

```
FROM DUAL;
```

```
RESULT1
```

```
-----
```

```
2020-08-16 00:00:00
```

1 row selected.

## 17.89 NEXTVAL

### Syntax

```
seq_name.NEXTVAL  
NEXTVAL( seq_name )  
NEXT VALUE FOR seq_name
```

### Description

It obtains the next value of the sequence object.

### Example

```
gSQL> CREATE SEQUENCE seq;  
Sequence created.  
gSQL> COMMIT;  
Commit complete.  
gSQL> SELECT seq.NEXTVAL FROM dual;  
SEQ.NEXTVAL  
-----  
1  
1 row selected.  
gSQL> SELECT NEXTVAL( seq ) FROM dual;  
NEXTVAL( SEQ )  
-----  
2  
1 row selected.  
gSQL> SELECT NEXT VALUE FOR seq FROM dual;  
NEXT VALUE FOR SEQ  
-----  
3  
1 row selected.
```

## 17.90 NULLIF

### Syntax

```
NULLIF( expr1, expr2 )
```

### Description

If `expr1` is equal to `expr2`, it returns `NULL`. If it is not equal it returns `expr1` which is the first argument.

If the data types of `expr1` and `expr2` are different, the result type is determined by **Result Type Combination Rule**.

`NULLIF` can be expressed by using `CASE` as follows.

- `NULLIF( expr1, expr2 )`

```
CASE WHEN expr1 = expr2 THEN NULL
      ELSE expr1
END
```

### Example

```
gSQL> SELECT NULLIF( 'SUN', 'SUN' ) AS RESULT1,
           NULLIF( 'SUN', 'MOON' ) AS RESULT2
        FROM DUAL;
RESULT1 RESULT2
-----
null    SUN
1 row selected.
```

## 17.91 NUMTODSINTERVAL

### Syntax

```
NUMTODSINTERVAL( num, interval_indicator )
```

### Description

It converts the number in `interval_indicator` unit to interval day to second type, then returns it.

The argument *number* is a numeric type.

The argument `interval_indicator` is the same character type as that of CHAR and VARCHAR, and it should be one of 'DAY', 'HOUR', 'MINUTE', 'SECOND' which is case insensitive.

If any argument is NULL, then NULL is returned as a result.

interval day(6) to second(6) type is returned as a result, and a user can not arbitrarily modify the precision. If the leading precision of the converted result exceeds the default precision, then an error is returned. If the fraction precision exceeds the default precision, then the rounded value is returned as a result.

### Example

- It converts *1 Day* to interval day to second type.

```
gSQL> SELECT NUMTODSINTERVAL(1, 'DAY') FROM DUAL;
NUMTODSINTERVAL(1, 'DAY')
-----
+000001 00:00:00.000000
1 row selected.
```

- It converts *36 Hour* to interval day to second type.

```
gSQL> SELECT NUMTODSINTERVAL(36, 'HOUR') FROM DUAL;
NUMTODSINTERVAL(36, 'HOUR')
-----
+000001 12:00:00.000000
1 row selected.
```

- It converts *1530 Minute* to interval day to second type.

```
gSQL> SELECT NUMTODSINTERVAL(1530, 'MINUTE') FROM DUAL;  
NUMTODSINTERVAL(1530, 'MINUTE')  
-----  
+000001 01:30:00.000000  
1 row selected.
```

- It converts *90100.1234567 Second* to interval day to second type.

```
gSQL> SELECT NUMTODSINTERVAL(90100.1234567, 'SECOND') FROM DUAL;  
NUMTODSINTERVAL(90100.1234567, 'SECOND')  
-----  
+000001 01:01:40.123457  
1 row selected.
```

## 17.92 NUMTOYMINTERVAL

### Syntax

```
NUMTOYMINTERVAL( num, interval_indicator )
```

### Description

It converts the number in `interval_indicator` unit to interval year to month type, then returns it.

The argument *number* is a numeric type.

The argument `interval_indicator` is the same character type as that of CHAR and VARCHAR, and it should be one of 'YEAR', 'MONTH' which is case insensitive.

If any argument is NULL, then NULL is returned as a result.

`interval year(6)` to month type is returned as a result, and a user can not arbitrarily modify the precision. If the leading precision of the converted result exceeds the default precision, then an error is returned.

### Example

- It converts *1 Year* to interval year to month type.

```
gSQL> SELECT NUMTOYMINTERVAL(1, 'YEAR') FROM DUAL;
NUMTOYMINTERVAL(1, 'YEAR')
-----
+000001-00
1 row selected.
```

- It converts *13.5 Month* to interval year to month type.

```
gSQL> SELECT NUMTOYMINTERVAL(13.5, 'MONTH') FROM DUAL;
NUMTOYMINTERVAL(13.5, 'MONTH')
-----
+000001-02
1 row selected.
```

## 17.93 NVL

### Syntax

```
NVL( expr1, expr2 )
```

### Description

If `expr1` is not NULL, then it returns `expr1`. If `expr1` is NULL, it returns `expr2`.

The result type is determined according to the data type of `expr1`.

If NULL is described in `expr1`, then the result type is determined according to the data type of `expr2`.

If the data type of `expr1` is a character type and a numeric type then it becomes the type including the range of `expr1` and `expr2` each.

If the data type of both `expr1` and `expr2` is CHAR type, then the result type is VARCHAR.

### Example

```
gSQL> SELECT I1, NVL( I1, 0 ) FROM T1;
  I1 NVL( I1, 0 )
----
  1           1
null          0
2 rows selected.
```



## 17.94 NVL2

### Syntax

```
NVL2( expr1, expr2, expr3 )
```

### Description

If `expr1` is not null, then it returns `expr2`. If `expr1` is NULL, it returns `expr3`.

The result type is determined according to the data type of `expr2`.

If NULL is described in `expr2`, then the result type is determined according to the data type of `expr3`.

If the data type of `expr2` is a character type and a numeric type then it becomes the type including the range of `expr2` and `expr3` each.

If the data type of both `expr2` and `expr3` is CHAR type, then the result type is VARCHAR.

### Example

```
gSQL> SELECT I1, NVL2( I1, I1 * 1000, 0 ) FROM T1;
```

```
  I1 NVL2( I1, I1 * 1000, 0 )
```

```
-----
```

```
  1                1000
```

```
 null                0
```

```
2 rows selected.
```

## 17.95 OCTET\_LENGTH

### Syntax

```
OCTET_LENGTH( str )  
BYTE_LENGTH( str )  
LENGTHB( str )
```

### Description

It returns the number of bytes in `str`.

The `str` argument data type can be a character type such as `CHARACTER`, `CHARACTER VARYING`, `CHARACTER LONG VARYING`, or a binary character type such as `BINARY`, `BINARY VARYING`, `BINARY LONG VARYING`.

If the `str` data type is `CHARACTER`, the white spaces are included in the calculation.  
If `str` is `NULL`, the result is also `NULL`.

It is an alias of `BYTE_LENGTH` and `LENGTHB`.

### Example

- Multi byte character set (e.g. UTF8): 1 byte character

```
gSQL> SELECT OCTET_LENGTH( 'OCTET_LENGTH' ) AS RESULT_1BYTE_CHARACTERS  
        FROM DUAL;  
RESULT_1BYTE_CHARACTERS  
-----  
                        12  
1 row selected.
```

- Multi byte character set (e.g. UTF8): 2 byte character

```
gSQL> SELECT OCTET_LENGTH( 'αβ' ) AS RESULT_2BYTE_CHARACTERS FROM DUAL;  
RESULT_2BYTE_CHARACTERS
```

-----  
4  
1 row selected.

## 17.96 OVERLAY

### Syntax

```
OVERLAY( str1 PLACING str2 FROM start_position [ FOR string_length ] )
```

### Description

It overlays the characters in the range between str1's start\_position and string\_length with str2.

The data types of str1 argument and str2 argument can be a character type such as CHARACTER, CHARACTER VARYING, CHARACTER LONG VARYING, or a binary character type such as BINARY, BINARY VARYING, BINARY LONG VARYING

The start\_position argument and string\_length argument can be numeric data type.

- OVERLAY function has the following result.
  - When FOR is specified.
 

```
SUBSTRING( str1 FROM 1 FOR (start_position - 1) )
|| str2
|| SUBSTRING( str1 FROM (start_position + string_length )
```
  - When FOR is omitted.
 

```
SUBSTRING( str1 FROM 1 FOR (start_position - 1) )
|| str2
|| SUBSTRING( str1 FROM (start_position + CHAR_LENGTH(str2))
```

For more information, refer to **SUBSTRING**.

The following table describes the result types.

**Table 17-15** Result type of OVERLAY

str1, str2 types	Result type
CHAR or VARCHAR	VARCHAR
LONG VARCHAR	LONG VARCHAR
BINARY or VARBINARY	VARBINARY
LONG VARBINARY	LONG VARBINARY

## Example

```
gSQL> SELECT
    OVERLAY( 'RESULT_OF_XXX_FUNC' PLACING 'OVERLAY' FROM 11 )
    AS RESULT1,
    OVERLAY( 'RESULT_OF_XXX_FUNC' PLACING 'OVERLAY' FROM 11 FOR 3 )
    AS RESULT2
FROM DUAL;
RESULT1          RESULT2
-----
RESULT_OF_OVERLAYC RESULT_OF_OVERLAY_FUNC
1 row selected.
```

## 17.97 PHYSICAL\_LENGTH

### Syntax

```
PHYSICAL_LENGTH( expr )
```

### Description

PHYSICAL\_LENGTH returns the number of internal expression information bytes in expr.

The expr argument can be any data type.

If an input argument is NULL, then the result is 0.

### Example

- When an input argument is NULL

```
gSQL> SELECT PHYSICAL_LENGTH( NULL ) AS RESULT FROM DUAL;  
RESULT  
-----  
      0  
1 row selected.
```

- The following example shows the number of NUMBER type bytes of 1, 123 and 12345.

```
gSQL> SELECT PHYSICAL_LENGTH( 1 ) AS RESULT FROM DUAL;  
RESULT  
-----  
      2  
1 row selected.  
gSQL> SELECT PHYSICAL_LENGTH( 123 ) AS RESULT FROM DUAL;  
RESULT  
-----  
      3  
1 row selected.  
gSQL> SELECT PHYSICAL_LENGTH( 12345 ) AS RESULT FROM DUAL;
```

RESULT

-----

4

1 row selected.

## 17.98 PI

### Syntax

PI()

### Description

It returns "π" constant.

### Example

```
gSQL> SELECT PI() AS RESULT FROM DUAL;  
          RESULT  
-----  
3.141592653589793E+0  
1 row selected.
```



## 17.99 POSITION

### Syntax

```
POSITION( str1 IN str2 )
```

### Description

It searches for the first str1 within str2, then returns its location.

The data type of str1 argument and str2 argument can be a character type such as CHARACTER, CHARACTER VARYING, CHARACTER LONG VARYING, or a binary character type BINARY, BINARY VARYING, BINARY LONG VARYING.

If str1 can not be found within str2, the return value is 0.

If str1 is found within str2, the position of str1 is returned, and the return value starts from 1.

The returned position value is calculated in character unit (not in byte unit).

If str1 or str2 is NULL, the return value is also NULL.

### Example

```
gSQL> SELECT POSITION( 'CHAR' IN 'LONG CHAR 2000' ) AS RESULT FROM DUAL;
```

```
RESULT
```

```
-----
```

```
6
```

```
1 row selected.
```

## 17.100 POWER

### Syntax

```
POWER( num1, num2 )
```

### Description

It squares num1 to num2, and returns the result.

The num1 argument and num2 argument can be a numeric data type.

If num1 is a negative number, num2 should be an integer.

If num1 or num2 is NULL, the result is also NULL.

### Example

```
gSQL> SELECT POWER( 2, 3 ) AS RESULT FROM DUAL;
```

```
RESULT
```

```
-----
```

```
      8
```

```
1 row selected.
```

# 17.101 RADIANS

## Syntax

```
RADIANS( degrees )
```

## Description

It returns the radians of degrees.

The degrees argument can be a numeric data type.

If the degrees argument is NULL, then NULL is returned.

## Example

```
gSQL> SELECT RADIANS( 180 ) AS RESULT FROM DUAL;  
          RESULT  
-----  
3.14159265358979  
1 row selected.
```

## 17.102 RANDOM

### Syntax

```
RANDOM( min, max )
```

### Description

It returns a random value in the range above min and below max.  
The min argument and max argument can be a numeric data type.  
If either min argument or the max argument is NULL, then NULL is returned.

### Example

```
gSQL> SELECT RANDOM( 1, 100 ) AS RESULT FROM DUAL;  
          RESULT  
-----  
34.1870528003201  
1 row selected.
```

## 17.103 REPEAT

### Syntax

```
REPEAT( str, num )
```

### Description

The string repeats `str` as many times as specified in `num`, and returns the result.

The `str` argument can be a character type such as `CHARACTER`, `CHARACTER VARYING`, `CHARACTER LONG VARYING`, or a binary character type such as `BINARY`, `BINARY VARYING`, `BINARY LONG VARYING`.

The `num` argument can be a numeric data type.

If either `str` or `num` is `NULL`, the result is also `NULL`.

If `num` is 0 or a negative number, the result is also `NULL`.

The following table describes the result types.

**Table 17-16** Result type of REPEAT

str type	Result type
CHAR or VARCHAR	VARCHAR
LONG VARCHAR	LONG VARCHAR
BINARY or VARBINARY	VARBINARY
LONG VARBINARY	LONG VARBINARY

### Example

```
gSQL> SELECT REPEAT( 'ab', 3 ) AS RESULT FROM DUAL;  
RESULT  
-----  
ababab  
1 row selected.
```

## 17.104 REPLACE

### Syntax

```
REPLACE( str, from, to )
```

### Description

It replaces all *from* strings in *str* string with *to* strings, and returns the result.

The *str* argument, the *from* argument, and the *to* argument can be a character data types such as CHAR, CHARACTER, CHARACTER VARYING, CHARACTER LONG VARYING.

If *str* is NULL, the result is also NULL.

If *from* is NULL, the *str* is returned without replacement.

If *to* value is omitted or NULL, the *str* value of which *from* is removed is returned.

The following table describes the result types.

**Table 17-17** Result type of REPLACE

str type	Result type
CHAR or VARCHAR	VARCHAR
LONG VARCHAR	LONG VARCHAR

### Example

```
gSQL> SELECT REPLACE( 'HI GLIESE', 'HI', 'HELLO' ) AS RESULT FROM DUAL;
RESULT
-----
HELLO GLIESE
1 row selected.
```

## 17.105 REVERSE

### Syntax

```
REVERSE( str )
```

### Description

REVERSE returns characters of str in reverse order.

The str argument can be types which is convertible to a character string type or a binary string type. A character string type is performed in a character unit, and a binary stringtype can be performed in a byte unit.

If str is NULL, then it returns NULL.

The following table describes the arguments and result types.

**Table 17-18** Argument and result type of REVERSE

str	Result type
CHAR	CHAR
VARCHAR	VARCHAR
LONG VARCHAR	LONG VARCHAR
BINARY	BINARY
VARBINARY	VARBINARY
LONG VARBINARY	LONG VARBINARY

### Example

```
gSQL> SELECT REVERSE( 'GOLDILOCKS' ) AS RESULT FROM DUAL;
RESULT
-----
SKCOLIDLOG
1 row selected.
gSQL> SELECT REVERSE( '선재소프트 2018' ) AS RESULT FROM DUAL;
```

RESULT

-----

8102 트프소재선

1 row selected.



## 17.106 ROUND( number )

### Syntax

```
ROUND( num [, scale ] )
```

### Description

It rounds off num based on scale, and returns the result.

The num argument and scale argument can be a numeric data type.

If scale is omitted, the scale becomes 0 and is executed as if it is ROUND(num, 0).

If scale is a positive number, it is rounded off based on the number of right digit of the decimal point. If scale is a negative number, it is rounded off based on the number of left digit of the decimal point.

If either num argument or the scale argument is NULL, then NULL is returned.

### Example

```
gSQL> SELECT ROUND( 152.4282, 2 ) AS RESULT FROM DUAL;  
RESULT  
-----  
152.43  
1 row selected.  
gSQL> SELECT ROUND( 152.4282, -2 ) AS RESULT FROM DUAL;  
RESULT  
-----  
200  
1 row selected.
```

## 17.107 ROUND( date )

### Syntax

ROUND( date [ , fmt ] )

### Description

It rounds off the date in the specified fmt unit, and returns the result.

The data type of date argument can be DATE, TIMESTAMP, TIMESTAMP WITH TIME ZONE.

The fmt argument can be a character type such as CHARACTER, CHARACTER VARYING.

If either date argument or the fmt argument is NULL, then NULL is returned.

The result type is always DATE regardless of the date argument data type.

If fmt is omitted, the default is DAY.

The following table describes the available format strings.

**Table 17-19** Available format string of fmt

String	Description
CC, SCC	It is represented in four digit year by rounding off from 51 year. (e.g. XX01)
YYYY, YEAR, SYYYY, SYEAR, YYY, YY, Y	It is rounded off from July 1st.
IYYY, IYY, IY, I	It is the year embracing the calendar week defined by ISO 8601 standards, and it is rounded off from July 1st.
Q	It is rounded off from the 16th day in the second month of the quarter.
MONTH, MON, MM, RM	It is rounded off from the 16th day.
WW	A week starts from January 1st of the year, and it is rounded off on wednesday 12 p.m of WEEK.
IW	It is the calendar week defined by ISO 8601 standards (1 ~ 52 week or 1 ~ 53 weeks), and it is rounded off on thursday 12 p.m.
W	A week starts from the 1st day of the month, and it is rounded off on wednesday 12 p.m of WEEK.
DDD, DD, J	It is rounded off at 12 p.m.
DAY, DY, D	It is rounded off on wednesday 12 p.m of WEEK.
HH, HH12, HH24	It is rounded off from 30 minutes.
MI	It is rounded off from 30 seconds.

## Example

```
gSQL> SELECT
    ROUND( TO_DATE( '2051-07-16', 'YYYY-MM-DD' ), 'CC' ) AS RESULT
    FROM DUAL;
RESULT
-----
2101-01-01
1 row selected.
gSQL> SELECT
    ROUND( TO_DATE( '2051-07-16', 'YYYY-MM-DD' ), 'YYYY' ) AS RESULT
    FROM DUAL;
RESULT
-----
2052-01-01
1 row selected.
gSQL> SELECT
    ROUND( TO_DATE( '2051-07-16', 'YYYY-MM-DD' ), 'MONTH' ) AS RESULT
    FROM DUAL;
RESULT
-----
2051-08-01
1 row selected.
gSQL> SELECT
    ROUND( TO_TIMESTAMP( '2001-05-05 15:22:33.999999',
                        'YYYY-MM-DD HH24:MI:SS.FF6' ) ) AS RESULT
    FROM DUAL;
RESULT
-----
2001-05-06
1 row selected.
```

## 17.108 ROWID\_GRID\_BLOCK\_ID

### Syntax

```
ROWID_GRID_BLOCK_ID( rowid )
```

### Description

It returns the GRID block ID.



It is a valid information in a cluster system.

### Example

```
gSQL> SELECT C1, ROWID_GRID_BLOCK_ID( ROWID ) FROM T1;
C1 ROWID_GRID_BLOCK_ID( ROWID )
-----
1          52
2          52
3          52
3 rows selected.
```

## 17.109 ROWID\_GRID\_BLOCK\_SEQ

### Syntax

```
ROWID_GRID_BLOCK_SEQ( rowid )
```

### Description

It returns the GRID block sequence.



It is a valid information in a cluster system.

### Example

```
gSQL> SELECT C1, ROWID_GRID_BLOCK_SEQ( ROWID ) FROM T1;  
C1 ROWID_GRID_BLOCK_SEQ( ROWID )
```

```
-----  
1                747465  
2                747466  
3                747467
```

```
3 rows selected.
```

## 17.110 ROWID\_MEMBER\_ID

### Syntax

```
ROWID_MEMBER_ID( rowid )
```

### Description

It returns the member ID.



It is a valid information in a cluster system.

### Example

```
gSQL> SELECT C1, ROWID_MEMBER_ID( ROWID ) FROM T1;
C1 ROWID_MEMBER_ID( ROWID )
-----
1          1
2          1
3          1
3 rows selected.
```

## 17.111 ROWID\_OBJECT\_ID

### Syntax

```
ROWID_OBJECT_ID( rowid )
```

### Description

It returns the object ID.



It is an invalid information in a cluster system.

### Example

```
gSQL> SELECT ROWID_OBJECT_ID( t1.ROWID ) FROM t1;  
ROWID_OBJECT_ID( T1.ROWID )
```

```
-----  
22012
```

```
22012
```

```
22012
```

```
22012
```

```
4 rows selected.
```

## 17.112 ROWID\_PAGE\_ID

### Syntax

```
ROWID_PAGE_ID( rowid )
```

### Description

It returns the page ID.



It is an invalid information in a cluster system.

### Example

```
gSQL> SELECT ROWID_PAGE_ID( t1.ROWID ) FROM t1;  
ROWID_PAGE_ID( T1.ROWID )
```

```
-----  
8227
```

```
8227
```

```
8227
```

```
8227
```

```
4 rows selected.
```



## 17.113 ROWID\_ROW\_NUMBER

### Syntax

```
ROWID_ROW_NUMBER( rowid )
```

### Description

It returns the row number.



It is an invalid information in a cluster system.

### Example

```
gSQL> SELECT ROWID_ROW_NUMBER( t1.ROWID ) FROM t1;  
ROWID_ROW_NUMBER( T1.ROWID )
```

```
-----  
0  
1  
2  
3
```

4 rows selected.

## 17.114 ROWID\_SHARD\_ID

### Syntax

```
ROWID_SHARD_ID( rowid )
```

### Description

It returns the shard ID.



It is a valid information in a cluster system.

### Example

```
gSQL> SELECT C1, ROWID_SHARD_ID( ROWID ) FROM T1;
C1 ROWID_SHARD_ID( ROWID )
-----
1                0
2                1
3                2
3 rows selected.
```

# 17.115 ROWID\_TABLESPACE\_ID

## Syntax

```
ROWID_TABLESPACE_ID( rowid )
```

## Description

It returns the tablespace ID.



It is an invalid information in a cluster system.

## Example

```
gSQL> SELECT ROWID_TABLESPACE_ID( t1.ROWID ) FROM t1;  
ROWID_TABLESPACE_ID( T1.ROWID )
```

```
-----  
2  
2  
2  
2
```

4 rows selected.

## 17.116 ROWNUM

### Syntax

ROWNUM

### Description

It sequentially allocates a number starting from 1 to rows which satisfy the WHERE condition.

It allows using ROWNUM in WHERE clause for the compatibility with Oracle.

However, to restrict the number of the query results, it is recommended to use **offset limit clause** (the SQL standard) as follows.

- (Non standard) Describing the number of the results by using ROWNUM

```
gSQL> SELECT * FROM t1 WHERE ROWNUM <= 3;
C1
--
A
B
C
3 rows selected.
```

- (SQL standard) Describing the number of the results by using FETCH statement

```
gSQL> SELECT * FROM t1 FETCH 3;
C1
--
A
B
C
3 rows selected.
```

To restrict the range of the query results, it is recommended to use OFFSET, FETCH statement as follows.

- (Non standard) Describing the range of the number of the results by using ROWNUM

```
gSQL> SELECT c1
        FROM ( SELECT ROWNUM rn, c1
                FROM t1 )
        WHERE rn BETWEEN 2 AND 3;
```

```
C1
--
B
C
2 rows selected.
```

- (SQL standard) Describing the range of the number of the results by using ROWNUM OFFSET, FETCH statement

```
gSQL> SELECT c1 FROM t1 OFFSET 1 FETCH 2;
```

```
C1
--
B
C
2 rows selected.
```

It is not recommended to use ROWNUM in WHERE clause for any other uses than the restriction of the number of the results.

The results for the same query may be different according to the execution method as follows when using the ambiguous condition (WHERE c1 < ROWNUM + 3).

- Creating the data

```
CREATE TABLE t1 ( c1 INTEGER );
CREATE INDEX t1_idx ON t1(c1);
INSERT INTO t1 VALUES (1);
INSERT INTO t1 VALUES (2);
INSERT INTO t1 VALUES (3);
INSERT INTO t1 VALUES (4);
INSERT INTO t1 VALUES (5);
COMMIT;
```

- In case of Oracle

```
SQL> SELECT ROWNUM, c1 FROM t1 WHERE c1 < ROWNUM + 3;
```

```
  ROWNUM      C1
-----
1          1
```

```

      2      2
SQL> DROP INDEX t1_idx;

```

- The index has been deleted.

```
SQL> SELECT ROWNUM, c1 FROM t1 WHERE c1 < ROWNUM + 3;
```

ROWNUM	C1
1	1
2	2
3	3
4	4
5	5

- In case of GOLDBLOCKS

```
gSQL> SELECT ROWNUM, c1 FROM t1 WHERE c1 < ROWNUM + 3;
```

```
ROWNUM C1
```

ROWNUM	C1
1	1
2	2
3	3
4	4
5	5

5 rows selected.

```
gSQL> DROP INDEX t1_idx;
```

Index dropped.

```
gSQL> SELECT ROWNUM, c1 FROM t1 WHERE c1 < ROWNUM + 3;
```

```
ROWNUM C1
```

ROWNUM	C1
1	1
2	2
3	3
4	4
5	5

5 rows selected.

## Example

```
gSQL> SELECT ROWNUM, c1 FROM t1;
```

```
ROWNUM C1
```

```
----- --
```

```
1 A
```

```
2 B
```

```
3 C
```

```
4 D
```

```
5 E
```

```
5 rows selected.
```

## 17.117 RPAD

### Syntax

```
RPAD( str, length, [, fill] )
```

### Description

It adds fill string to the right side of str until the string's length becomes length, and it returns the result.

The str argument can be a character type such as CHARACTER, CHARACTER VARYING, CHARACTER LONG VARYING, or a binary character type such as BINARY, BINARY VARYING, BINARY LONG VARYING.

The length argument can be a numeric type.

length means the number of characters, and its maximum range is the maximum PRECISION of the result type.

If fill is omitted, a white space is added.

If str is longer than length, it cuts the str as long as the length, then returns it.

If any of str, length, fill is NULL, the result is also NULL.

If length is 0 or a negative number, the result is NULL.

The following table describes the result types.

**Table 17-20** Result type of RPAD

str type	Result type
CHAR or VARCHAR	VARCHAR
LONG VARCHAR	LONG VARCHAR
BINARY or VARBINARY	VARBINARY
LONG VARBINARY	LONG VARBINARY

### Example

```
gSQL> SELECT RPAD('AA', 5) AS RESULT1,
           RPAD('AA', 5, 'X') AS RESULT2,
           RPAD('AA', 1) AS RESULT3
```



```
FROM DUAL;  
RESULT1 RESULT2 RESULT3  
-----  
AA      AAXXX  A  
1 row selected.
```

## 17.118 RTRIM

### Syntax

```
RTRIM( trim_source [, trim_character ] )
```

### Description

It removes the matching characters by comparing from the right side of trim\_character in trim\_source until the matching character does not exist. Then it returns the result.

The data type of trim\_character argument and trim\_source argument can be a character type such as CHARACTER, CHARACTER VARYING, CHARACTER LONG VARYING or a binary data type such as BINARY, BINARY VARYING, BINARY LONG VARYING.

If any of trim\_character, trim\_source is NULL, the result is NULL.

If trim\_character is omitted, a single blank space ( ' ' ) is specified by default.

The following table describes the result types.

**Table 17-21** Result type of RTRIM

trim_source type, trim_character type	Result type
CHAR or VARCHAR	VARCHAR
LONG VARCHAR	LONG VARCHAR
BINARY or VARBINARY	VARBINARY
LONG VARBINARY	LONG VARBINARY

### Example

```
gSQL> SELECT RTRIM('      rtrim      ') AS RESULT1,
             RTRIM('_____rtrim_____', '_') AS RESULT2
       FROM DUAL;
RESULT1    RESULT2
-----
rtrim _____rtrim
```

1 row selected.

## 17.119 SESSION\_ID

### Syntax

```
SESSION_ID()
```

### Description

It obtains the current session ID.

### Example

```
gSQL> SELECT SESSION_ID() FROM dual;
SESSION_ID()
-----
                4
1 row selected.
```

# 17.120 SESSION\_SERIAL

## Syntax

SESSION\_SERIAL()

## Description

It obtains the serial number of current session.

## Example

```
gSQL> SELECT SESSION_SERIAL() FROM dual;
SESSION_SERIAL()
-----
                16
1 row selected.
```

## 17.121 SESSION\_USER

### Syntax

```
SESSION_USER[()]
```

### Description

It returns the session user.

The user information is managed in three types as follows.

- Logon user: It is a user who performed login, and it is maintained until the connection is closed.
- Session user: It is as same as the first logon user, but it can be changed using the SET SESSION AUTHORIZATION statement.
- Current user: It is generally as same as the session user, but it is temporarily changed internally in system to control access when using the PSM, view.
  - The session user and current user is similar to the difference between the unix system's real user and the effective user.

### Example

```
% gsql sys gliese
gSQL> SET SESSION AUTHORIZATION test;
Session set.
gSQL> SELECT LOGON_USER() AS result1, SESSION_USER() AS result2 FROM DUAL;
RESULT1 RESULT2
-----
SYS      TEST
1 row selected.
```

## 17.122 SHARD\_GROUP\_ID

### Syntax

```
SHARD_GROUP_ID( table_name, shard_key_value [ , ... ] )
```

### Description

It returns the group ID managing the shard which stores `shard_key_value` when the shard strategy is defined in the `table_name`.

The `table_name` (an input argument) should be described by an identifier. If an object corresponding to the `table_name` is not a base table, or if the shard strategy is not defined, then an error occurs.

The `shard_key_value` (an input argument) should be listed in an order of shard key column in the shard strategy defined in the `table_name`. If the number of `shard_key_value` and the number of shard key column is not same, then an error occurs.

The result type is `NATIVE_BIGINT`.



It is a valid information in a cluster system.

### Example

```
gSQL> SELECT T1.C1, SHARD_GROUP_ID( T1, T1.C1 ) FROM T1;
C1 SHARD_GROUP_ID( T1, T1.C1 )
-- -----
A                               1
B                               2
C                               3
3 rows selected.
gSQL> SELECT SHARD_GROUP_ID( T1, 'B' ) FROM DUAL;
SHARD_GROUP_ID( T1, 'B' )
-----
2
```

1 row selected.



## 17.123 SHARD\_GROUP\_NAME

### Syntax

```
SHARD_GROUP_NAME( table_name, shard_key_value [ , ... ] )
```

### Description

It returns the group NAME managing the shard which stores `shard_key_value` when the shard strategy is defined in the `table_name`.

The `table_name` (an input argument) should be described by an identifier. If an object corresponding to the `table_name` is not a base table, or if the shard strategy is not defined, then an error occurs.

The `shard_key_value` (an input argument) should be listed in an order of shard key column in the shard strategy defined in the `table_name`. If the number of `shard_key_value` and the number of shard key column is not same, then an error occurs.

The result type is VARCHAR.



It is a valid information in a cluster system.

### Example

```
gSQL> SELECT T1.C1, SHARD_GROUP_NAME( T1, T1.C1 ) FROM T1;
C1 SHARD_GROUP_NAME( T1, T1.C1 )
-- -----
A  G1
B  G2
C  G3
3 rows selected.
gSQL> SELECT SHARD_GROUP_NAME( T1, 'B' ) FROM DUAL;
SHARD_GROUP_NAME( T1, 'B' )
-----
G2
```

1 row selected.

## 17.124 SHARD\_ID

### Syntax

```
SHARD_ID( table_name, shard_key_value [, ... ] )
```

### Description

It returns the ID for the shard which stores `shard_key_value` when the shard strategy is defined in the table `table_name`.

The `table_name` (an input argument) should be described by an identifier. If an object corresponding to the `table_name` is not a base table, or if the shard strategy is not defined, then an error occurs.

The `shard_key_value` (an input argument) should be listed in an order of shard key column in the shard strategy defined in the `table_name`. If the number of `shard_key_value` and the number of shard key column is not same, then an error occurs.

The result type is `NATIVE_BIGINT`.



It is a valid information in a cluster system.

### Example

```
gSQL> SELECT T1.C1, SHARD_ID( T1, T1.C1 ) FROM T1;
C1 SHARD_ID( T1, T1.C1 )
-- -----
A                0
B                1
C                2
3 rows selected.
gSQL> SELECT SHARD_ID( T1, 'B' ) FROM DUAL;
SHARD_ID( T1, 'B' )
-----
1
```

1 row selected.

## 17.125 SHARD\_NAME

### Syntax

```
SHARD_NAME( table_name, shard_key_value [, ... ] )
```

### Description

It returns the NAME for the shard which stores `shard_key_value` when the shard strategy is defined in the `table_name`.

The `table_name` (an input argument) should be described by an identifier. If an object corresponding to the `table_name` is not a base table, or if the shard strategy is not defined, then an error occurs.

The `shard_key_value` (an input argument) should be listed in an order of shard key column in the shard strategy defined in the `table_name`. If the number of `shard_key_value` and the number of shard key column is not same, then an error occurs.

The result type is VARCHAR.



It is a valid information in a cluster system.

### Example

```
gSQL> SELECT T1.C1, SHARD_NAME( T1, T1.C1 ) FROM T1;
C1 SHARD_NAME( T1, T1.C1 )
-- -----
A  S1
B  S2
C  S3
3 rows selected.
gSQL> SELECT SHARD_NAME( T1, 'B' ) FROM DUAL;
SHARD_NAME( T1, 'B' )
-----
S2
```

1 row selected.

## 17.126 SHIFT\_LEFT

### Syntax

```
SHIFT_LEFT( num, cnt )
```

### Description

It moves num to the left as many as cnt bits, and returns the movement values.

The data type of input num argument and cnt argument can be NATIVE\_SMALLINT, NATIVE\_INTEGER, NATIVE\_BIGINT, or the type which can be converted to NATIVE\_BIGINT.

When converting to NATIVE\_BIGINT type, the decimal point is truncated.

cnt is masked with 6 bit, and it is processed to a value in the range within 6 bit.

If either num or cnt is NULL, then NULL is returned.

The result type is NATIVE\_BIGINT.

### Example

```
gSQL> SELECT SHIFT_LEFT(1, 3) FROM DUAL;  
SHIFT_LEFT(1, 3)  
-----  
8  
1 row selected.
```

## 17.127 SHIFT\_RIGHT

### Syntax

```
SHIFT_RIGHT( num, cnt )
```

### Description

It moves num to the right as many as cnt bits, and returns the movement values.

The data type of input num argument and cnt argument can be NATIVE\_SMALLINT, NATIVE\_INTEGER, NATIVE\_BIGINT, or the type which can be converted to NATIVE\_BIGINT.

When converting to NATIVE\_BIGINT type, the decimal point is truncated.

cnt is masked with 6 bit, and it is processed to a value in the range within 6 bit.

If either num or cnt is NULL, then NULL is returned.

The result type is NATIVE\_BIGINT.

### Example

```
gSQL> SELECT SHIFT_RIGHT(8, 3) FROM DUAL;  
SHIFT_RIGHT(8, 3)  
-----  
1  
1 row selected.
```



# 17.128 SIGN

## Syntax

`SIGN( num )`

## Description

It returns the sign of num.

The num argument can be a numeric data type.

The return value is as follows.

- If  $\text{num} < 0$ , -1 is returned.
- If  $\text{num} = 0$ , 0 is returned.
- If  $\text{num} > 0$ , 1 is returned.

If num is NULL, then NULL is returned.

## Example

```
gSQL> SELECT SIGN(-10) AS RESULT1,  
          SIGN(0) AS RESULT2,  
          SIGN(10) AS RESULT3 FROM DUAL;
```

```
RESULT1 RESULT2 RESULT3
```

```
-----
```

```
      -1         0         1
```

```
1 row selected.
```

## 17.129 SIN

### Syntax

```
SIN( num )
```

### Description

It returns the sine value of num.  
If num is NULL, then NULL is returned.

### Example

```
gSQL> SELECT SIN( 0 ) AS RESULT FROM DUAL;  
RESULT  
-----  
      0  
1 row selected.
```

## 17.130 SPLIT\_PART

### Syntax

```
SPLIT_PART( string, delimiter, field )
```

### Description

It returns a character string of the field by specifying a character as delimiter within a string.

The data type of string argument and delimiter argument can be a character data type such as CHARACTER, CHARACTER VARYING, CHARACTER LONG VARYING.

The field argument can be a numeric data type.

If any of string, delimiter, field is NULL, the result is also NULL.

The value of field should be a numeric value above 1, and if it is 0 or a negative number, an error is returned.

The following table describes the result types.

**Table 17-22** Result type of SPLIT\_PART

string type	Result type
CHAR or VARCHAR	VARCHAR
LONG VARCHAR	LONG VARCHAR

### Example

```
gSQL> SELECT SPLIT_PART( 'AB;CD;EF;GH', ';', 3 ) AS RESULT FROM DUAL;
```

```
RESULT
```

```
-----
```

```
EF
```

```
1 row selected.
```

## 17.131 SQRT

### Syntax

```
SQRT( num )
```

### Description

It returns the square root of num.

The num argument can be a numeric type, and it should not be a negative number, but above 0. If the num argument is NULL, then NULL is returned.

### Example

```
gSQL> SELECT SQRT( 9 ) AS RESULT FROM DUAL;  
RESULT  
-----  
      3  
1 row selected.
```

# 17.132 STATEMENT\_DATE

## Syntax

```
STATEMENT_DATE()  
CURRENT_DATE [( )]
```

## Description

The current date(DATE type) value is obtained.

The differences among the functions to obtain the current date are as follows.

- TRANSACTION\_DATE(): All date values in the transaction are same.
- STATEMENT\_DATE(): All date values in an SQL statement are same.
- CLOCK\_DATE(): Whenever the function is called, the current date value is obtained.

## Example

```
gSQL> SELECT STATEMENT_DATE() AS result FROM t1;  
RESULT  
-----  
2013-12-12  
2013-12-12  
2013-12-12  
3 rows selected.
```

## 17.133 STATEMENT\_LOCALTIME

### Syntax

```
STATEMENT_LOCALTIME()  
LOCALTIME [()]
```

### Description

The current TIME WITHOUT TIME ZONE type value based on the session time is obtained.

LOCALTIME is an SQL standard function.

The differences among the functions to obtain the current time are as follows.

- TRANSACTION\_LOCALTIME(): All time values in the transaction are same.
- STATEMENT\_LOCALTIME(): All time values in an SQL statement are same.
- CLOCK\_LOCALTIME(): Whenever the function is called, the current time value is obtained.

### Example

All rows have the same time value.

```
gSQL> SELECT STATEMENT_LOCALTIME() AS result FROM t1;  
RESULT  
-----  
16:18:50.775870  
16:18:50.775870  
16:18:50.775870  
3 rows selected.
```

# 17.134 STATEMENT\_LOCALTIMESTAMP

## Syntax

```
STATEMENT_LOCALTIMESTAMP()  
LOCALTIMESTAMP [()]
```

## Description

The current `TIMESTAMP WITHOUT TIME ZONE` type value based on the session time is obtained.

`LOCALTIMESTAMP` is an SQL standard function.

The differences among the functions to obtain the current timestamp are as follows.

- `TRANSACTION_LOCALTIMESTAMP()`: All timestamp values in the transaction are same.
- `STATEMENT_LOCALTIMESTAMP()`: All timestamp values in an SQL statement are same.
- `CLOCK_LOCALTIMESTAMP()`: Whenever the function is called, the current timestamp value is obtained.

## Example

All rows have the same value.

```
gSQL> SELECT STATEMENT_LOCALTIMESTAMP() FROM t1;  
STATEMENT_LOCALTIMESTAMP()  
-----  
2013-12-12 16:23:39.782187  
2013-12-12 16:23:39.782187  
2013-12-12 16:23:39.782187  
3 rows selected.
```

## 17.135 STATEMENT\_TIME

### Syntax

```
STATEMENT_TIME()  
CURRENT_TIME [( )]
```

### Description

The current TIME WITH TIME ZONE type value is obtained.

CURRENT\_TIME is an SQL standard function.

The differences among the functions to obtain the current time are as follows.

- TRANSACTION\_TIME(): All time values in the transaction are same.
- STATEMENT\_TIME(): All time values in an SQL statement are same.
- CLOCK\_TIME(): Whenever the function is called, the current time value is obtained.

### Example

All rows have the same time value.

```
gSQL> SELECT STATEMENT_TIME() AS result FROM t1;  
RESULT  
-----  
16:28:19.268513 +09:00  
16:28:19.268513 +09:00  
16:28:19.268513 +09:00  
3 rows selected.
```



# 17.136 STATEMENT\_TIMESTAMP

## Syntax

```
STATEMENT_TIMESTAMP()  
CURRENT_TIMESTAMP [()]
```

## Description

The current `TIMESTAMP WITH TIME ZONE` type value is obtained.

`CURRENT_TIMESTAMP` is an SQL standard function.

The differences among the functions to obtain the current timestamp are as follows.

- `TRANSACTION_TIMESTAMP()`: All timestamp values in the transaction are same.
- `STATEMENT_TIMESTAMP()`: All timestamp values in an SQL statement are same.
- `CLOCK_TIMESTAMP()`: Whenever the function is called, the current timestamp value is obtained.

## Example

All rows have the same value.

```
gSQL> SELECT STATEMENT_TIMESTAMP() AS result FROM t1;  
RESULT  
-----  
2013-12-12 16:36:11.032957 +09:00  
2013-12-12 16:36:11.032957 +09:00  
2013-12-12 16:36:11.032957 +09:00  
3 rows selected.
```

## 17.137 STATEMENT\_VIEW\_SCN

### Syntax

STATEMENT\_VIEW\_SCN()

### Description

It obtains VIEW SCN of the current STATEMENT.

### Example

```
gSQL> SELECT STATEMENT_VIEW_SCN() FROM dual;  
STATEMENT_VIEW_SCN()  
-----  
17697.658.17880  
1 row selected.
```

## 17.138 STATEMENT\_VIEW\_SCN\_DCN

### Syntax

```
STATEMENT_VIEW_SCN_DCN()
```

### Description

It obtains the Domain Change Number (DCN) value of the current STATEMENT's VIEW SCN.

### Example

```
gSQL> SELECT STATEMENT_VIEW_SCN_DCN() FROM dual;  
STATEMENT_VIEW_SCN_DCN()  
-----  
658  
1 row selected.
```

## 17.139 STATEMENT\_VIEW\_SCN\_GCN

### Syntax

```
STATEMENT_VIEW_SCN_GCN()
```

### Description

It obtains the Global Change Number (GCN) value of the current STATEMENT's VIEW SCN.

### Example

```
gSQL> SELECT STATEMENT_VIEW_SCN_GCN() FROM dual;  
STATEMENT_VIEW_SCN_GCN()  
-----  
17697  
1 row selected.
```

## 17.140 STATEMENT\_VIEW\_SCN\_LCN

### Syntax

```
STATEMENT_VIEW_SCN_LCN()
```

### Description

It obtains the Local Change Number (LCN) value of the current STATEMENT's VIEW SCN.

### Example

```
gSQL> SELECT STATEMENT_VIEW_SCN_LCN() FROM dual;
STATEMENT_VIEW_SCN_LCN()
-----
                           17880
1 row selected.
```

## 17.141 STDDEV

### Syntax

```
STDDEV( [ ALL | DISTINCT ] expr )
```

### Description

It is an aggregation function, and it obtains the standard deviation of an expr set.

If ALL is specified, this function is performed for all values. If DISTINCT is specified, this function is performed for the values of which the duplicates were deleted from. If it is not specified, it is processed as if ALL is specified.

If the number of expr sets except for NULL after deleting the duplicates by using DISTINCT is one, then it returns 0 like as **VARIANCE**.

The following table describes the arguments and result types.

**Table 17-23** Argument and result type of STDDEV

expr	Result type
NATIVE_INTEGER family <ul style="list-style-type: none"> <li>NATIVE_SMALLINT</li> <li>NATIVE_INTEGER</li> <li>NATIVE_BIGINT</li> </ul>	NATIVE_DOUBLE
NUMBER	NUMBER
NATIVE_DOUBLE family <ul style="list-style-type: none"> <li>NATIVE_REAL</li> <li>NATIVE_DOUBLE</li> </ul>	NATIVE_DOUBLE

GOLDILOCKS gets the standard deviation as follows.

- If the number of expr sets are 1, then it returns 0.
- If the number of expr sets are bigger than 1, It returns the value of **STDDEV\_SAMP( expr )**.



The standard deviation is a positive square root of a variance, and it is obtained calculating the square root of the variance. In other words, the STDDEV function is as same as the square root of **VARIANCE** function.

```
STDDEV( [ ALL ] expr )  
= SQRT( VARIANCE( [ ALL ] expr ) )
```

```
STDDEV( DISTINCT expr )  
= SQRT( VARIANCE( DISTINCT expr ) )
```

## Example

```
gSQL> SELECT STDDEV(c1) FROM t1;  
      STDDEV(C1)  
-----  
11.4978258814438  
1 row selected.  
gSQL> SELECT STDDEV(ALL c1) FROM t1;  
      STDDEV(ALL C1)  
-----  
11.4978258814438  
1 row selected.  
gSQL> SELECT STDDEV(DISTINCT c1) FROM t1;  
      STDDEV(DISTINCT C1)  
-----  
      13.2759180473518  
1 row selected.
```

## 17.142 STDDEV\_POP

### Syntax

`STDDEV_POP( expr )`

### Description

It is an aggregation function, and it obtains the population standard deviation of an `expr` set. If the number of `expr` sets except for NULL is one, then it returns 0.

The following table describes the arguments and result types.

**Table 17-24** Argument and result type of STDDEV\_POP

expr	Result type
NATIVE_INTEGER family <ul style="list-style-type: none"> <li>NATIVE_SMALLINT</li> <li>NATIVE_INTEGER</li> <li>NATIVE_BIGINT</li> </ul>	NATIVE_DOUBLE
NUMBER	NUMBER
NATIVE_DOUBLE family <ul style="list-style-type: none"> <li>NATIVE_REAL</li> <li>NATIVE_DOUBLE</li> </ul>	NATIVE_DOUBLE



The population standard deviation is a positive square root of a population variance, and it is obtained by calculating the square root of the population variance. In other words, the `STDDEV_POP` function is as same as the square root of `VAR_POP` function.

```
STDDEV_POP( expr )
= SQRT( VAR_POP( expr ) )
```



## Example

```
gSQL> SELECT STDDEV_POP(c1) FROM t1;  
STDDEV_POP(c1)  
-----  
10.283968105746  
1 row selected.
```

## 17.143 STDDEV\_SAMP

### Syntax

`STDDEV_SAMP( expr )`

### Description

It is an aggregation function, and it obtains the sample standard deviation of an expr set. If the number of expr sets except for NULL is one, then it returns NULL.

The following table describes the arguments and result types.

**Table 17-25** Argument and result type of STDDEV\_SAMP

expr	Result type
NATIVE_INTEGER family <ul style="list-style-type: none"> <li>NATIVE_SMALLINT</li> <li>NATIVE_INTEGER</li> <li>NATIVE_BIGINT</li> </ul>	NATIVE_DOUBLE
NUMBER	NUMBER
NATIVE_DOUBLE family <ul style="list-style-type: none"> <li>NATIVE_REAL</li> <li>NATIVE_DOUBLE</li> </ul>	NATIVE_DOUBLE



The sample standard deviation is a positive square root of a sample variance, and it is obtained by calculating the square root of the sample variance. In other words, the STDDEV\_SAMP function is as same as the square root of **VAR\_SAMP** function.

```
STDDEV_SAMP( expr )
= SQRT( VAR_SAMP( expr ) )
```

## Example

```
gSQL> SELECT STDDEV_SAMP(c1) FROM t1;  
STDDEV_SAMP(C1)  
-----  
11.4978258814438  
1 row selected.
```

## 17.144 SUBSTR

### Syntax

```
SUBSTR( str FROM start_position [ FOR string_length ] )  
SUBSTR( str, start_position [ , string_length ] )
```

### Description

It is an alias of 17.146 SUBSTRING.

### Example

- Multi byte character set (e.g. UTF8): 1 byte character

```
gSQL> SELECT  
      SUBSTR( 'DATABASE MANAGEMENT SYSTEM', 10, 10 ) AS RESULT  
      FROM DUAL;  
RESULT  
-----  
MANAGEMENT  
1 row selected.
```

- Multi byte character set (e.g. UTF8): 2 bytes or 3 bytes character

```
gSQL> SELECT SUBSTR( ' " αβ ≠ AB " ', 2, 5 ) AS RESULT FROM DUAL;  
RESULT  
-----  
αβ ≠ AB  
1 row selected.
```

## 17.145 SUBSTRB

### Syntax

```
SUBSTRB( str, start_position [ , string_length ] )
```

### Description

It extracts characters which are within string\_length range from start\_position, and returns the result for str.

This function is as same as **SUBSTRING** function, except that start\_position and string\_length of the SUBSTR function are calculated in byte units.

### Example

- Multi byte character set (e.g. UTF8): 1 byte character

```
gSQL> SELECT
      SUBSTRB( 'DATABASE MANAGEMENT SYSTEM', 10, 10 ) AS RESULT
      FROM DUAL;
RESULT
-----
MANAGEMENT
1 row selected.
```

- Multi byte character set (e.g. UTF8): 2 bytes or 3 bytes character

```
gSQL> SELECT SUBSTRB( ' " αβ ≠ AB " ', 4, 11 ) AS RESULT FROM DUAL;
RESULT
-----
αβ ≠ AB
1 row selected.
```

## 17.146 SUBSTRING

### Syntax

```
SUBSTRING( str FROM start_position [ FOR string_length ] )  
SUBSTRING( str, start_position [ , string_length ] )
```

### Description

It extracts characters which are within `string_length` range from `start_position`, and returns the result for `str`.

The `str` argument data type can be a character data type such as `CHARACTER`, `CHARACTER VARYING`, `CHARACTER LONG VARYING`, or a binary data type such as `BINARY`, `BINARY VARYING`, `BINARY LONG VARYING`.

The `start_position` argument and `string_length` argument can be a numeric data type.

If any of `str`, `start_position`, `string_length` is `NULL`, the result is `NULL`.

The `start_position` and `string_length` start from 1, and they are calculated in character unit according to character set (not in byte unit).

If `start_position` is 0, the `start_position` is assigned to 1.

If `start_position` is a positive number, it searches for the position forwards (towards right) from the beginning of `str`.

If `start_position` is a negative number, it searches for the position backwards (towards left) from the end of `str`.

If `string_length` is omitted, characters from the `start_position` to the last character of `str`, is returned.

If `string_length` is 0 or a negative number, the result is `NULL`.

If `start_position` > (`str` length), the result is `NULL`.

If  $(\text{str length} + \text{start\_position}) < 0$ , the result is `NULL`.

It is an alias of **SUBSTR**.

For more information, refer to **SUBSTRB**.

The following table describes the result types.

**Table 17-26** Result type of SUBSTRING

str type	Result type
CHAR or VARCHAR	VARCHAR
LONG VARCHAR	LONG VARCHAR
BINARY or VARBINARY	VARBINARY
LONG VARBINARY	LONG VARBINARY

## Example

- Multi byte character set (e.g. UTF8): 1 byte character

```
gSQL> SELECT
      SUBSTRING( 'DATABASE MANAGEMENT SYSTEM' FROM 10 FOR 10 ) AS RESULT
    FROM DUAL;
RESULT
-----
MANAGEMENT
1 row selected.
```

- Multi byte character set (e.g. UTF8): 2 bytes or 3 bytes character

```
gSQL> SELECT SUBSTRING( ' " αβ ≠ AB " ' FROM 2 FOR 5 ) AS RESULT FROM DUAL;
RESULT
-----
αβ ≠ AB
1 row selected.
```

## 17.147 SUM

### Syntax

```
SUM( [ ALL | DISTINCT ] expr )
```

### Description

It is an aggregate function and the sum of expr value is obtained.

If ALL is explicitly specified, aggregation is executed for all values.

If DISTINCT is explicitly specified, aggregation is executed for the values which exclude duplicate values.

If ALL or DISTINCT is not explicitly specified, it is processed in the same way as when ALL is specified.

### Example

```
gSQL> SELECT SUM(c1) FROM t1;
SUM(C1)
-----
      6
1 row selected.
```



# 17.148 SYSDATE

## Syntax

SYSDATE

## Description

It obtains the current DATE type value based on the OS time of the database server.

## Example

```
gSQL> SELECT SYSDATE FROM t1;
SYSDATE
-----
2013-12-12
2013-12-12
2013-12-12
3 rows selected.
```

## 17.149 SYS\_EXTRACT\_UTC

### Syntax

```
SYS_EXTRACT_UTC( datetime_with_timezone )
```

### Description

It returns the UTC (Coordinated Universal Time—formerly Greenwich Mean Time) value. If the timezone is not specified, it is calculated as session time zone.

The data type of an input argument can be time, time with time zone, timestamp, timestamp with time zone.

The result type is time or timestamp type.

### Example

```
gSQL> SELECT
  SYS_EXTRACT_UTC(
    TO_TIMESTAMP_TZ( '2017-05-25 00:00:00.000000 +09:00',
                    'YYYY-MM-DD HH24:MI:SS.FF6 TZH:TZM' )
  ) AS RESULT
FROM DUAL;
RESULT
-----
2017-05-24 15:00:00.000000
1 row selected.
```

# 17.150 SYSTIME

## Syntax

SYSTIME

## Description

It obtains the current TIME WITH TIME ZONE type value based on the OS time of the database server.

## Example

```
gSQL> SELECT SYSTIME FROM t1;
SYSTIME
-----
16:30:46.954941 +09:00
16:30:46.954941 +09:00
16:30:46.954941 +09:00
3 rows selected.
```

## 17.151 SYSTIMESTAMP

### Syntax

SYSTIMESTAMP

### Description

It obtains the current `TIMESTAMP WITH TIME ZONE` type value based on the OS time of the database server.

### Example

```
gSQL> SELECT SYSTIMESTAMP FROM t1;
SYSTIMESTAMP
-----
2013-12-12 16:37:34.432241 +09:00
2013-12-12 16:37:34.432241 +09:00
2013-12-12 16:37:34.432241 +09:00
3 rows selected.
```

# 17.152 TAN

## Syntax

TAN( num )

## Description

It returns the tangent value of num in radians unit.  
If num is NULL, then NULL is returned.

## Example

```
gSQL> SELECT TAN( 1 ) AS RESULT FROM DUAL;  
          RESULT  
-----  
1.5574077246549  
1 row selected.
```

## 17.153 TO\_BASE64

### Syntax

```
TO_BASE64( str )
```

### Description

It converts `str` by using base64 encoding, and returns the converted character.

`str` argument can be a character type such as CHARACTER, CHARACTER VARYING, CHARACTER LONG VARYING, a type which can be converted to a character type, or a binary character type such as BINARY, BINARY VARYING, BINARY LONG VARYING.

The result type is a character such as CHARACTER VARYING or CHARACTER LONG VARYING.

If `str` is NULL, the result value is also NULL.

Base64 encoding represents 8 bit binary data in 64 characters consisting of ascii areas.

64 characters consist of A~Z, a~z, 0~9, +, /.

6 bit is represented as a character, and three characters (24 bits) are represented with 4 characters as a unit.

If the encoded characters can not fill 4 characters, then others are filled with '='.

If encoded characters are over 76, then a newline is added and they are divided into multiple lines.

Use FROM\_BASE64() function to decode the base64 encoded character.

The newline, carriage return, tab, space are ignored when decoding base64.

For more information, refer to FROM\_BASE64.

### Example

```
gSQL> SELECT TO_BASE64( 'abc' ), TO_BASE64( 'abcd' ) FROM DUAL;
```

```
TO_BASE64( 'abc' ) TO_BASE64( 'abcd' )
```

```
-----
```

```
YWJj
```

```
YWJjZA==
```

```
1 row selected.
```

## 17.154 TO\_CHAR( datetime )

### Syntax

```
TO_CHAR( datetime [, fmt ] )
```

### Description

It converts datetime to a string in the specified fmt format, and returns the result.

The datetime argument data type can be DATE, TIMESTAMP, TIMESTAMP WITH TIME ZONE, TIME, TIME WITH TIME ZONE, INTERVAL.

The fmt argument data type can be a character data type such as CHARACTER, CHARACTER VARYING. If any argument is NULL, then NULL is returned.

If fmt is omitted, it follows the default format.

- DATE: Refer to **NLS\_DATE\_FORMAT**.
- TIMESTAMP: Refer to **NLS\_TIMESTAMP\_FORMAT**.
- TIMESTAMP WITH TIME ZONE: Refer to **NLS\_TIMESTAMP\_WITH\_TIME\_ZONE\_FORMAT**.
- TIME: Refer to **NLS\_TIME\_FORMAT**.
- TIME WITH TIME ZONE: Refer to **NLS\_TIME\_WITH\_TIME\_ZONE\_FORMAT**.

If the data type of the datetime argument is INTERVAL, it is converted to a string then returned regardless of fmt.

For more information about the string which can be specified in fmt, refer to **Datetime Format String**.

The result type is CHARACTER VARYING.

### Example

The following is an example of when fmt is omitted, and NLS\_DATE\_FORMAT = 'YYYY-MM-DD'.

```
gSQL> SELECT
      TO_CHAR( TO_DATE( '2012-03-15', 'YYYY-MM-DD' ) ) AS RESULT
FROM DUAL;
```

```
RESULT
```

```
-----
```

```
2012-03-15
```

```
1 row selected.
```

The following is an example of when `fmt` is specified.

```
gSQL> SELECT
```

```
    TO_CHAR( TO_DATE('2012-03-15','YYYY-MM-DD'), 'DD-MON-YY' ) AS RESULT
```

```
FROM DUAL;
```

```
RESULT
```

```
-----
```

```
15-MAR-12
```

```
1 row selected.
```



## 17.155 TO\_CHAR( number )

### Syntax

```
TO_CHAR( number [, fmt ] )
```

### Description

It converts the number to a string in the specified fmt format, and returns the result.

The number argument can be a numeric data type.

The fmt argument data type can be a character data type such as CHARACTER, CHARACTER VARYING.

If fmt is omitted, all significant digits are converted to the string and returned.

For more information about the string which can be specified in fmt, refer to **Number Format String**.

If any input argument is NULL, then NULL is returned.

The result type is CHARACTER VARYING.

### Example

```
gSQL> SELECT TO_CHAR( 12500000 ) AS RESULT FROM DUAL;
RESULT
-----
12500000
1 row selected.
gSQL> SELECT TO_CHAR( 12500000, 'S999,999,999' ) AS RESULT FROM DUAL;
RESULT
-----
+12,500,000
1 row selected.
```

## 17.156 TO\_DATE

### Syntax

```
TO_DATE( str [, fmt ] )
```

### Description

It converts the `str` string in the specified `fmt` format to `DATE` type, and returns the result.

The `str` argument and `fmt` argument data type can be a character data type such as `CHARACTER`, `CHARACTER VARYING`, `CHARACTER LONG VARYING`.

If `fmt` is omitted, the default format is `NLS_DATE_FORMAT`, and in this case `str` should be the default format string.

For more information about the string which can be specified in `fmt`, refer to **Datetime Format String**.

For more information, refer to **NLS\_DATE\_FORMAT**.

If either `str` or `fmt` is `NULL`, then `NULL` is returned.

The result type is `DATE`.

### Example

The following is an example of when `fmt` is omitted, and `NLS_DATE_FORMAT = 'YYYY-MM-DD'`.

```
gSQL> SELECT TO_DATE( '2009-07-29' ) AS RESULT FROM DUAL;
RESULT
-----
2009-07-29
1 row selected.
```

The following is an example of when `fmt` is specified.

```
gSQL> SELECT TO_DATE( '29-JUL-09', 'DD-MON-YY' ) AS RESULT FROM DUAL;
RESULT
-----
```

2009-07-29

1 row selected.

## 17.157 TO\_NATIVE\_BIGINT

### Syntax

```
TO_NATIVE_BIGINT( str [, fmt ] )
```

### Description

It converts the `str` string in the specified `fmt` format to `NATIVE_BIGINT` type, and returns the result.

The `str` argument and `fmt` argument data type can be a character data type such as `CHARACTER`, `CHARACTER VARYING`, `CHARACTER LONG VARYING`.

If any of `str`, `fmt` is `NULL`, the result is also `NULL`.

For more information about the string which can be specified in `fmt`, refer to **Number Format String**.

The result type is `NATIVE_BIGINT`.

### Example

```
gSQL> SELECT TO_NATIVE_BIGINT( '123.45' ) AS RESULT1,  
            TO_NATIVE_BIGINT( '+123.45', 'S999.99' ) AS RESULT2  
        FROM DUAL;  
RESULT1 RESULT2  
-----  
123      123  
1 row selected.
```

# 17.158 TO\_NATIVE\_DOUBLE

## Syntax

```
TO_NATIVE_DOUBLE( str [, fmt ] )
```

## Description

It converts the `str` string in the specified `fmt` format to `NATIVE_DOUBLE` type, and returns the result.

The data type of `str` argument and `fmt` argument can be a character data type such as `CHARACTER`, `CHARACTER VARYING`, `CHARACTER LONG VARYING`.

If any of `str`, `fmt` is `NULL`, the result is also `NULL`.

For more information about the string which can be specified in `fmt`, refer to **Number Format String**.

The result type is `NATIVE_DOUBLE`.

## Example

```
gSQL> SELECT TO_NATIVE_DOUBLE( '123.45' ) AS RESULT1,  
            TO_NATIVE_DOUBLE( '+123.45', 'S999.99' ) AS RESULT2  
        FROM DUAL;  
RESULT1 RESULT2  
-----  
123.45  123.45  
1 row selected.
```

## 17.159 TO\_NATIVE\_INTEGER

### Syntax

```
TO_NATIVE_INTEGER( str [, fmt ] )
```

### Description

It converts the `str` string in the specified `fmt` format to `NATIVE_INTEGER` type, and returns the result.

The data type of `str` argument and `fmt` argument can be a character data type such as `CHARACTER`, `CHARACTER VARYING`, `CHARACTER LONG VARYING`.

If any of `str`, `fmt` is `NULL`, the result is also `NULL`.

For more information about the string which can be specified in `fmt`, refer to **Number Format String**.

The result type is `NATIVE_INTEGER`.

### Example

```
gSQL> SELECT TO_NATIVE_INTEGER( '123.45' ) AS RESULT1,  
            TO_NATIVE_INTEGER( '+123.45', 'S999.99' ) AS RESULT2  
        FROM DUAL;  
RESULT1 RESULT2  
-----  
123      123  
1 row selected.
```

## 17.160 TO\_NATIVE\_REAL

### Syntax

```
TO_NATIVE_REAL( str [, fmt ] )
```

### Description

It converts the `str` string in the specified `fmt` format to `NATIVE_REAL` type, and returns the result.

The data type of `str` argument and `fmt` argument can be a character data type such as `CHARACTER`, `CHARACTER VARYING`, `CHARACTER LONG VARYING`.

If any of `str`, `fmt` is `NULL`, the result is also `NULL`.

For more information about the string which can be specified in `fmt`, refer to **Number Format String**.

The result type is `NATIVE_REAL`.

### Example

```
gSQL> SELECT TO_NATIVE_REAL( '123.45' ) AS RESULT1,  
            TO_NATIVE_REAL( '+123.45', 'S999.99' ) AS RESULT2  
        FROM DUAL;  
RESULT1 RESULT2  
-----  
123.45  123.45
```

## 17.161 TO\_NATIVE\_SMALLINT

### Syntax

```
TO_NATIVE_SMALLINT( str [, fmt ] )
```

### Description

It converts the `str` string in the specified `fmt` format to `NATIVE_SMALLINT` type, and returns the result.

The data type of `str` argument and `fmt` argument can be a character data type such as `CHARACTER`, `CHARACTER VARYING`, `CHARACTER LONG VARYING`.

If any of `str`, `fmt` is `NULL`, the result is also `NULL`.

For more information about the string which can be specified in `fmt`, refer to **Number Format String**.

The result type is `NATIVE_SMALLINT`.

### Example

```
gSQL> SELECT TO_NATIVE_SMALLINT( '123.45' ) AS RESULT1,  
            TO_NATIVE_SMALLINT( '+123.45', 'S999.99' ) AS RESULT2  
        FROM DUAL;  
RESULT1 RESULT2  
-----  
123      123  
1 row selected.
```



## 17.162 TO\_NUMBER

### Syntax

```
TO_NUMBER( str [, fmt] )
```

### Description

It converts the `str` string in the specified `fmt` format to NUMBER type, and returns the result.

The data type of `str` argument and `fmt` argument can be a character data type such as CHARACTER, CHARACTER VARYING, CHARACTER LONG VARYING.

If any of `str`, `fmt` is NULL, the result is also NULL.

For more information about the string which can be specified in `fmt`, refer to **Number Format String**.

The result type is NUMBER.

### Example

```
gSQL> SELECT TO_NUMBER( '123.45' ) AS RESULT1,  
            TO_NUMBER( '+123.45', 'S999.99' ) AS RESULT2  
            FROM DUAL;  
RESULT1 RESULT2  
-----  
123.45  123.45  
1 row selected.
```

## 17.163 TO\_TIME

### Syntax

```
TO_TIME( str [, fmt ] )
```

### Description

It converts the `str` string in the specified `fmt` format to `TIME` type, and returns the result.

The data type of `str` argument and `fmt` argument can be a character data type such as `CHARACTER`, `CHARACTER VARYING`, `CHARACTER LONG VARYING`.

If `fmt` is omitted, the default format is `NLS_TIME_FORMAT`, and in this case `str` should be the default format string.

For more information about the string which can be specified in `fmt`, refer to **Datetime Format String**.

For more information, refer to **NLS\_TIME\_FORMAT**.

If either `str` or `fmt` is `NULL`, then `NULL` is returned.

The result type is `TIME`.

### Example

The following is an example of when `fmt` is omitted, and `NLS_TIME_FORMAT = 'HH24:MI:SS.FF6'`.

```
gSQL> SELECT TO_TIME( '11:22:33.999999' ) AS RESULT FROM DUAL;
RESULT
-----
11:22:33.999999
1 row selected.
```

The following is an example of when `fmt` is specified.

```
gSQL> SELECT
      TO_TIME( '112233.999999/P.M.', 'HH12MISS.FF6/P.M.' ) AS RESULT
FROM DUAL;
```

RESULT

-----

23:22:33.999999

1 row selected.

## 17.164 TO\_TIME\_TZ

### Syntax

```
TO_TIME_TZ( str [, fmt ] )
```

### Description

It is an alias of `TO_TIME_WITH_TIME_ZONE`.

For more information, refer to `NLS_TIME_WITH_TIME_ZONE_FORMAT`.

### Example

The following is an example of when `fmt` is omitted, and `NLS_TIME_WITH_TIME_ZONE_FORMAT = 'HH24:MI:SS.FF6 TZH:TZM'`.

```
gSQL> SELECT TO_TIME_TZ( '11:22:33.999999 +09:00' ) AS RESULT FROM DUAL;
RESULT
-----
11:22:33.999999 +09:00
1 row selected.
```

The following is an example of when `fmt` is specified.

```
gSQL> SELECT TO_TIME_TZ( '11:22:33.999999 +09:00 PM',
                        'HH12:MI:SS.FF6 TZH:TZM PM' ) AS RESULT
FROM DUAL;
RESULT
-----
23:22:33.999999 +09:00
1 row selected.
```

## 17.165 TO\_TIME\_WITH\_TIME\_ZONE

### Syntax

```
TO_TIME_WITH_TIME_ZONE( str [, fmt ] )  
TO_TIME_TZ( str [, fmt ] )
```

### Description

It converts the `str` string in the specified `fmt` format to TIME WITH TIME ZONE type, and returns the result.

The data type of `str` argument and `fmt` argument can be a character data type such as CHARACTER, CHARACTER VARYING, CHARACTER LONG VARYING.

If `fmt` is omitted, the default format is NLS\_TIME\_WITH\_TIME\_ZONE\_FORMAT, and in this case `str` should be the default format string.

For more information about the string which can be specified in `fmt`, refer to **Datetime Format String**

For more information, refer to **NLS\_TIME\_WITH\_TIME\_ZONE\_FORMAT**.

If either `str` or `fmt` is NULL, then NULL is returned.

It is an alias of TO\_TIME\_TZ.

The result type is TIME WITH TIME ZONE.

### Example

The following is an example of when `fmt` is omitted, and NLS\_TIME\_WITH\_TIME\_ZONE\_FORMAT = 'HH24:MI:SS.FF6 TZH:TZM'.

```
gSQL> SELECT  
      TO_TIME_WITH_TIME_ZONE( '11:22:33.999999 +09:00' ) AS RESULT  
      FROM DUAL;  
RESULT  
-----  
11:22:33.999999 +09:00  
1 row selected.
```

The following is an example of when `fmt` is specified.

```
gSQL> SELECT
      TO_TIME_WITH_TIME_ZONE( '11:22:33.999999 +09:00 PM' ,
                             'HH12:MI:SS.FF6 TZH:TZM PM' )
      AS RESULT
      FROM DUAL;
RESULT
-----
23:22:33.999999 +09:00
1 row selected.
```

# 17.166 TO\_TIMESTAMP

## Syntax

```
TO_TIMESTAMP( str [, fmt ] )
```

## Description

It converts the `str` string in the specified `fmt` format to `TIMESTAMP` type, and returns the result.

The data type of `str` argument and `fmt` argument can be a character data type such as `CHARACTER`, `CHARACTER VARYING`, `CHARACTER LONG VARYING`.

If `fmt` is omitted, the default format is `NLS_TIMESTAMP_FORMAT`, and in this case `str` should be the default format string.

For more information about the string which can be specified in `fmt`, refer to **Datetime Format String**.

For more information, refer to **NLS\_TIMESTAMP\_FORMAT**.

If either `str` or `fmt` is `NULL`, then `NULL` is returned.

The result type is `TIMESTAMP`.

## Example

The following is an example of when `fmt` is omitted, and `NLS_TIMESTAMP_FORMAT = 'YYYY-MM-DD HH24:MI:SS.FF6'`.

```
gSQL> SELECT
      TO_TIMESTAMP( '2009-07-29 11:22:33.999999' ) AS RESULT
      FROM DUAL;
RESULT
-----
2009-07-29 11:22:33.999999
1 row selected.
```

The following is an example of when `fmt` is specified.

```
gSQL> SELECT
      TO_TIMESTAMP( '090729 112233999999 PM', 'YMMDD HH12MISSFF6 PM' )
      AS RESULT
      FROM DUAL;
```

RESULT

```
-----
2009-07-29 23:22:33.999999
```

1 row selected.



# 17.167 TO\_TIMESTAMP\_TZ

## Syntax

```
TO_TIMESTAMP_TZ( str [, fmt ] )
```

## Description

It is an alias of `TO_TIMESTAMP_WITH_TIME_ZONE`.

For more information, refer to `NLS_TIMESTAMP_WITH_TIME_ZONE_FORMAT`.

## Example

The following is an example of when `fmt` is omitted, and `NLS_TIMESTAMP_WITH_TIME_ZONE_FORMAT` = 'YYYY-MM-DD HH24:MI:SS.FF6 TZH:TZM'.

```
gSQL> SELECT
      TO_TIMESTAMP_TZ( '2009-07-29 11:22:33.999999 +09:00' ) AS RESULT
    FROM DUAL;
RESULT
-----
2009-07-29 11:22:33.999999 +09:00
1 row selected.
```

The following is an example of when `fmt` is specified.

```
gSQL> SELECT
      TO_TIMESTAMP_TZ( '29-JUL-09 11:22:33.999999 +09:00',
                      'DD-MON-RR HH12:MI:SS.FF6 TZH:TZM' ) AS RESULT
    FROM DUAL;
RESULT
-----
2009-07-29 11:22:33.999999 +09:00
1 row selected.
```

## 17.168 TO\_TIMESTAMP\_WITH\_TIME\_ZONE

### Syntax

```
TO_TIMESTAMP_WITH_TIME_ZONE( str [, fmt ] )
TO_TIMESTAMP_TZ( str [, fmt ] )
```

### Description

It converts the `str` string in the specified `fmt` format to `TIMESTAMP WITH TIME ZONE` type, and returns the result.

The data type of `str` argument and `fmt` argument can be a character data type such as `CHARACTER`, `CHARACTER VARYING`, `CHARACTER LONG VARYING`.

If `fmt` is omitted, the default format is `NLS_TIMESTAMP_WITH_TIME_ZONE_FORMAT`, and in this case `str` should be the default format string.

For more information about the string which can be specified in `fmt`, refer to [Datetime Format String](#).

For more information, refer to `NLS_TIMESTAMP_WITH_TIME_ZONE_FORMAT`.

If either `str` or `fmt` is `NULL`, then `NULL` is returned.

It is an alias of `TO_TIMESTAMP_TZ`.

The result type is `TIMESTAMP WITH TIME ZONE`.

### Example

The following is an example of when `fmt` is omitted, and `NLS_TIMESTAMP_WITH_TIME_ZONE_FORMAT = 'YYYY-MM-DD HH24:MI:SS.FF6 TZH:TZM'`.

```
gSQL> SELECT
      TO_TIMESTAMP_WITH_TIME_ZONE( '2009-07-29 11:22:33.999999 +09:00' )
      AS RESULT
      FROM DUAL;

RESULT
-----
```

```
2009-07-29 11:22:33.999999 +09:00  
1 row selected.
```

The following is an example of when fmt is specified.

```
gSQL> SELECT  
      TO_TIMESTAMP_WITH_TIME_ZONE( '29-JUL-09 11:22:33.999999 +09:00' ,  
                                  'DD-MON-RR HH12:MI:SS.FF6 TZH:TZM' )  
      AS RESULT  
      FROM DUAL;  
RESULT  
-----  
2009-07-29 11:22:33.999999 +09:00  
1 row selected.
```

## 17.169 TRANSACTION\_DATE

### Syntax

```
TRANSACTION_DATE()
```

### Description

It obtains the current date (DATE type) value based on the session time.

The differences among the functions to obtain the current date are as follows.

- TRANSACTION\_DATE(): All date values in the transaction are same.
- STATEMENT\_DATE(): All date values in an SQL statement are same.
- CLOCK\_DATE(): Whenever the function is called, the current date value is obtained.

### Example

All date values are always same within a single transaction.

```
gSQL> SELECT TRANSACTION_DATE() FROM dual;
TRANSACTION_DATE()
-----
2013-12-12
1 row selected.
gSQL> SELECT TRANSACTION_DATE() FROM dual;
TRANSACTION_DATE()
-----
2013-12-12
1 row selected.
gSQL> COMMIT;
Commit complete.
gSQL> SELECT TRANSACTION_DATE() FROM dual;
TRANSACTION_DATE()
-----
2013-12-13
1 row selected.
```

# 17.170 TRANSACTION\_LOCALTIME

## Syntax

```
TRANSACTION_LOCALTIME()
```

## Description

It obtains the current TIME WITHOUT TIME ZONE type value based on the session time.

The differences among the functions to obtain the current time are as follows.

- TRANSACTION\_LOCALTIME(): All time values in the transaction are same.
- STATEMENT\_LOCALTIME(): All time values in an SQL statement are same.
- CLOCK\_LOCALTIME(): Whenever the function is called, the current time value is obtained.

## Example

All time values are always same within a single transaction.

```
gSQL> SELECT TRANSACTION_LOCALTIME() FROM dual;
TRANSACTION_LOCALTIME()
-----
16:43:24.391834
1 row selected.
gSQL> SELECT TRANSACTION_LOCALTIME() FROM dual;
TRANSACTION_LOCALTIME()
-----
16:43:24.391834
1 row selected.
gSQL> COMMIT;
Commit complete.
gSQL> SELECT TRANSACTION_LOCALTIME() FROM dual;
TRANSACTION_LOCALTIME()
-----
16:43:32.651833
1 row selected.
```

## 17.171 TRANSACTION\_LOCALTIMESTAMP

### Syntax

```
TRANSACTION_LOCALTIMESTAMP()
```

### Description

It obtains the current `TIMESTAMP WITHOUT TIME ZONE` type value based on the session time.

The differences among the functions to obtain the current timestamp are as follows.

- `TRANSACTION_LOCALTIMESTAMP()`: All timestamp values in the transaction are same.
- `STATEMENT_LOCALTIMESTAMP()`: All timestamp values in an SQL statement are same.
- `CLOCK_LOCALTIMESTAMP()`: Whenever the function is called, the current timestamp value is obtained.

### Example

All timestamp values are always same within a single transaction.

```
gSQL> SELECT TRANSACTION_LOCALTIMESTAMP() FROM dual;
TRANSACTION_LOCALTIMESTAMP()
-----
2013-12-12 16:43:32.651833
1 row selected.
gSQL> SELECT TRANSACTION_LOCALTIMESTAMP() FROM dual;
TRANSACTION_LOCALTIMESTAMP()
-----
2013-12-12 16:43:32.651833
1 row selected.
gSQL> COMMIT;
Commit complete.
gSQL> SELECT TRANSACTION_LOCALTIMESTAMP() FROM dual;
TRANSACTION_LOCALTIMESTAMP()
-----
2013-12-12 16:46:07.831834
1 row selected.
```

## 17.172 TRANSACTION\_TIME

### Syntax

```
TRANSACTION_TIME()
```

### Description

It obtains the current TIME WITH TIME ZONE type value based on the session time.

The differences among the functions to obtain the current time are as follows.

- TRANSACTION\_TIME(): All time values in the transaction are same.
- STATEMENT\_TIME(): All time values in an SQL statement are same.
- CLOCK\_TIME(): Whenever the function is called, the current time value is obtained.

### Example

All time values are always same within a single transaction.

```
gSQL> SELECT TRANSACTION_TIME() FROM dual;
TRANSACTION_TIME()
-----
16:46:07.831834 +09:00
1 row selected.
gSQL> SELECT TRANSACTION_TIME() FROM dual;
TRANSACTION_TIME()
-----
16:46:07.831834 +09:00
1 row selected.
gSQL> COMMIT;
Commit complete.
gSQL> SELECT TRANSACTION_TIME() FROM dual;
TRANSACTION_TIME()
-----
16:48:00.691827 +09:00
1 row selected.
```

## 17.173 TRANSACTION\_TIMESTAMP

### Syntax

```
TRANSACTION_TIMESTAMP()
```

### Description

It obtains the current `TIMESTAMP WITH TIME ZONE` type value based on the session time.

The differences among the functions to obtain the current timestamp are as follows.

- `TRANSACTION_TIMESTAMP()`: All timestamp values in the transaction are same.
- `STATEMENT_TIMESTAMP()`: All timestamp values in an SQL statement are same.
- `CLOCK_TIMESTAMP()`: Whenever the function is called, the current timestamp value is obtained.

### Example

All timestamp values are always same within a single transaction.

```
gSQL> SELECT TRANSACTION_TIMESTAMP() FROM dual;
TRANSACTION_TIMESTAMP()
-----
2013-12-12 16:48:00.691827 +09:00
1 row selected.
gSQL> SELECT TRANSACTION_TIMESTAMP() FROM dual;
TRANSACTION_TIMESTAMP()
-----
2013-12-12 16:48:00.691827 +09:00
1 row selected.
gSQL> COMMIT;
Commit complete.
gSQL> SELECT TRANSACTION_TIMESTAMP() FROM dual;
TRANSACTION_TIMESTAMP()
-----
2013-12-12 16:49:26.291827 +09:00
1 row selected.
```



# 17.174 TRANSLATE

## Syntax

`TRANSLATE( string, from, to )`

## Description

It replaces characters. It replaces characters of *string* which corresponds to the character of *from* with the character of *to* at the same position as the character of *from*.

The data type of the *string* argument, the *from* argument, and the *to* argument can be a data type such as CHARACTER, CHARACTER VARYING, CHARACTER LONG VARYING.

If any of *string*, *from*, *to* is NULL, the result is also NULL.

- When the character of *string* which are as same as those of *from* exists,
  - If the length of *from* is as same as that of *to*, then it is replaced with the character of *to* at the same position as the character of *from*.
  - If the length of *from* is longer than that of *to*, then characters of *from* at the position after that of *to* length are deleted from the string.
  - If the character of *from* is duplicate, then it is replaced with the character of *to* at the same position as the first duplicate character of *from*.
- When the character of *string* which is as same as those of *from* does not exist, then the string is not replaced.

The following table describes the result types.

**Table 17-27** Result type of TRANSLATE

string type	Result type
CHAR or VARCHAR	VARCHAR
LONG VARCHAR	LONG VARCHAR

## Example

- When the character of string which are as same as those of *from* exists, then it is replaced with the character of *to* at the same position as the character of *from*.
  - A → Z, C → Y, E → X, G → W

```
gSQL> SELECT TRANSLATE('ABCDEFG', 'ACEG', 'ZYXW') AS RESULT
FROM DUAL;
RESULT
-----
ZBYDXFW
1 row selected.
```

- If the length of *from* string is longer than that of *to* string, then characters of *from* at the position after that of *to* string length are deleted *from* the string, and replaced.
  - A → Z, C → Y, deleting E, deleting G

```
gSQL> SELECT TRANSLATE('ABCDEFG', 'ACEG', 'ZY') AS RESULT
FROM DUAL;
RESULT
-----
ZBYDF
1 row selected.
```

## 17.175 TRIM

### Syntax

```
TRIM([ [ LEADING | TRAILING | BOTH ] [trim_character] FROM ] trim_source)
```

### Description

It removes the matching characters by comparing trim\_character in trim\_source from the LEADING, TRAILING, BOTH direction until the matching character does not exist. Then it returns the result.

The trim\_character argument and trim\_source argument can be a character data type such as CHARACTER, CHARACTER VARYING, CHARACTER LONG VARYING or a binary character data type such as BINARY, BINARY VARYING, BINARY LONG VARYING.

If any of trim\_character, trim\_source is NULL, the result is NULL.

- [ LEADING | TRAILING | BOTH ]
  - LEADING: Removes trim\_character from the beginning of trim\_source.
  - TRAILING: Removes trim\_character from the back of trim\_source.
  - BOTH: Removes trim\_character from the both direction (the beginning, the back) of trim\_source.
- trim\_character should be a single character.
- If trim\_character is omitted, single blank space ( ' ' ) is specified by default.
- When FROM is specified
  - [ LEADING | TRAILING | BOTH ], trim\_character or [ LEADING | TRAILING | BOTH ] trim\_character should be specified.
    - e.g. TRIM( LEADING FROM ' abc' ) , TRIM( 'x' FROM 'xabc' ) , TRIM( LEADING 'x' FROM 'xabc' )
  - If [ LEADING | TRAILING | BOTH ] is omitted, BOTH is specified by default.
- When FROM is omitted.
  - It is TRIM( trim\_source ), it is executed in the same way as TRIM( BOTH ' ' FROM trim\_source ).

The following table describes the result types.

**Table 17-28** Result type of TRIM

trim_character, trim_source type	Result type
CHAR or VARCHAR	VARCHAR
LONG VARCHAR	LONG VARCHAR

trim_character, trim_source type	Result type
BINARY or VARBINARY	VARBINARY
LONG VARBINARY	LONG VARBINARY

## Example

```

gSQL> SELECT TRIM( LEADING '_' FROM '__TRIM FUNCTION__' ) AS RESULT
        FROM DUAL;
RESULT
-----
TRIM FUNCTION__
1 row selected.
gSQL> SELECT TRIM( TRAILING '_' FROM '__TRIM FUNCTION__' ) AS RESULT
        FROM DUAL;
RESULT
-----
__TRIM FUNCTION
1 row selected.
gSQL> SELECT TRIM( BOTH '_' FROM '__TRIM FUNCTION__' ) AS RESULT
        FROM DUAL;
RESULT
-----
TRIM FUNCTION
1 row selected.

```

## 17.176 TRUNC( number )

### Syntax

```
TRUNC( num [ , scale ] )
```

### Description

It truncates the num based on scale, then returns the result.

The num argument and scale argument can be a numeric type.

If either the num argument or the scale argument is NULL, then NULL is returned.

If scale is omitted, the scale becomes 0, and it is executed as same as TRUNC( num, 0 ).

If scale is a positive number, it is truncated based on the number of right digit of the decimal point.

If scale is a negative number, it is truncated off based on the number of left digit of the decimal point.

### Example

```
gSQL> SELECT TRUNC( 142.4282, 2 ) AS RESULT FROM DUAL;
RESULT
-----
142.42
1 row selected.
gSQL> SELECT TRUNC( 142.4282, -2 ) AS RESULT FROM DUAL;
RESULT
-----
    100
1 row selected.
```

## 17.177 TRUNC( date )

### Syntax

TRUNC( date [ , fmt ] )

### Description

It truncates the date in a specified *fmt* unit, and returns the result.

The *date* argument data type can be DATE, TIMESTAMP, TIMESTAMP WITH TIME ZONE.

The *fmt* argument data type can be a character data type such as CHARACTER, CHARACTER VARYING.

If either *date* argument or *fmt* argument is NULL, then NULL is returned.

The result type is always DATE regardless of the input date type.

If *fmt* is omitted, the default is *DAY*, and the available format string is described in the following table.

**Table 17-29** Available format string in *fmt*

Format string	Description
CC, SCC	Century
YYYY, YEAR, SYYYY, SYEAR, YYY, YY, Y	Year
IYYY, IYY, IY, I	The year embracing the calendar week defined by ISO 8601 standards
Q	Quarter
MONTH, MON, MM, RM	Month
WW	The week whose first week starts from January 1st of the year
IW	The week containing the first thursday of the year designated as the calendar week by ISO 8601 standards ( 1 ~ 52 week or 1 ~ 53 weeks) becomes the first week.
W	The week whose first week starts from the first day of the month
DDD, DD, J	Day
DAY, DY, D	Day of week
HH, HH12, HH24	Hour
MI	Minute

## Example

```
gSQL> SELECT
    TRUNC( TO_DATE( '2051-07-16', 'YYYY-MM-DD' ), 'CC' ) AS RESULT
    FROM DUAL;
RESULT
-----
2001-01-01
1 row selected.
gSQL> SELECT
    TRUNC( TO_DATE( '2051-07-16', 'YYYY-MM-DD' ), 'YYYY' ) AS RESULT
    FROM DUAL;
RESULT
-----
2051-01-01
1 row selected.
gSQL> SELECT
    TRUNC( TO_DATE( '2051-07-16', 'YYYY-MM-DD' ), 'MONTH' ) AS RESULT
    FROM DUAL;
RESULT
-----
2051-07-01
1 row selected.
gSQL> SELECT
    TRUNC( TO_TIMESTAMP( '2001-05-05 11:22:33.999999',
        'YYYY-MM-DD HH24:MI:SS.FF6' ) ) AS RESULT
    FROM DUAL;
RESULT
-----
2001-05-05
1 row selected.
```

## 17.178 UPPER

### Syntax

```
UPPER( str )
```

### Description

It returns the uppercase characters of str.

The str argument can be a character data type such as CHARACTER, CHARACTER VARYING, CHARACTER LONG VARYING.

If str is NULL, the result is NULL.

The return type is as same as the str argument type.

### Example

```
gSQL> SELECT UPPER( 'spring' ) AS RESULT FROM DUAL;  
RESULT  
-----  
SPRING  
1 row selected.
```



# 17.179 UNHEX

## Syntax

```
UNHEX( str )
```

## Description

str argument is a hexadecimal character and this function represents it as each byte and returns it as a binary string.

The input argument can be a character type such as CHARACTER VARYING, CHARACTER LONG VARYING. The result type is a binary character type such as BINARY VARYING or BINARY LONG VARYING.

If str is NULL, then the result value is also NULL.

If str includes a character which does not belong to the hexadecimal range, then it returns an error.

For more information, refer to [HEX](#).

## Example

```
gSQL> SELECT UNHEX( HEX( 'abc' ) ) FROM DUAL;  
UNHEX( HEX( 'abc' ) )  
-----  
616263  
1 row selected.
```

## 17.180 UNHEX\_TO\_CHARSTR

### Syntax

```
UNHEX_TO_CHARSTR( str )
```

### Description

str argument is a hexadecimal character and this function represents it as each byte and returns it as a character string.

The input argument can be a character type such as CHARACTER VARYING, CHARACTER LONG VARYING. The result type is a character type such as CHARACTER VARYING, CHARACTER LONG VARYING.

If str is NULL, then the result value is also NULL.

If str includes a character which does not belong to the hexadecimal range, then it returns an error.

For more information, refer to [HEX](#), [UNHEX](#).

### Example

```
gSQL> SELECT UNHEX_TO_CHARSTR( '616263' ) FROM DUAL;
UNHEX_TO_CHARSTR( '616263' )
-----
abc
1 row selected.
gSQL> SELECT UNHEX_TO_CHARSTR( HEX( 'abc' ) ) FROM DUAL;
UNHEX_TO_CHARSTR( HEX( 'abc' ) )
-----
abc
1 row selected.
```

# 17.181 USER\_ID

## Syntax

USER\_ID ( )

## Description

It obtains the current user's number ID.



In cluster system, the value may vary depending on the connected server.

It is recommended to use **CURRENT\_USER** function obtaining the current username.

## Example

```
% gsql test test
gSQL> SELECT USER_ID() FROM dual;
USER_ID()
-----
          6
1 row selected.
```

## 17.182 UUID

### Syntax

UUID()

### Description

It creates the universal unique identifier, then returns it.  
The return type is VARBINARY type, and it internally consists of 16 bytes.

### Example

```
gSQL> SELECT HEX( UUID() ) FROM DUAL;  
HEX( UUID() )  
-----  
E6F0A5C2387511E8B95259E479C2FD50  
1 row selected.
```

## 17.183 VAR\_POP

### Syntax

`VAR_POP( expr )`

### Description

It is an aggregation function, and it obtains the population variance of an expr set. If the number of expr sets except for NULL is one, then it returns 0.

The following table describes the arguments and result types.

**Table 17-30** Argument and result type of VAR\_POP

expr	Result type
NATIVE_INTEGER family <ul style="list-style-type: none"> <li>NATIVE_SMALLINT</li> <li>NATIVE_INTEGER</li> <li>NATIVE_BIGINT</li> </ul>	NATIVE_DOUBLE
NUMBER	NUMBER
NATIVE_DOUBLE family <ul style="list-style-type: none"> <li>NATIVE_REAL</li> <li>NATIVE_DOUBLE</li> </ul>	NATIVE_DOUBLE



The population variance is a variance of the population (entire) group, and it is the average of the square value of deviation. In other words, it is calculated by extracting the population average (the entire average) from each value of the data, and squaring each value, then adding them together and dividing them by the number of datas in the population group. This value is used to figure out how far each value is from the average value.

For more information, refer to `STDDEV_POP`.

## Example

```
gSQL> SELECT VAR_POP(c1) FROM t1;
```

```
VAR_POP(C1)
```

```
-----
```

```
105.76
```

```
1 row selected.
```

## 17.184 VAR\_SAMP

### Syntax

`VAR_SAMP( expr )`

### Description

It is an aggregation function, and it obtains the sample variance of an expr set. If the number of expr sets except for NULL is one, then it returns NULL.

The following table describes the arguments and result types.

**Table 17-31** Argument and result type of VAR\_SAMP

expr	Result type
NATIVE_INTEGER family <ul style="list-style-type: none"> <li>• NATIVE_SMALLINT</li> <li>• NATIVE_INTEGER</li> <li>• NATIVE_BIGINT</li> </ul>	NATIVE_DOUBLE
NUMBER	NUMBER
NATIVE_DOUBLE family <ul style="list-style-type: none"> <li>• NATIVE_REAL</li> <li>• NATIVE_DOUBLE</li> </ul>	NATIVE_DOUBLE



Unlike the population variance dealing with the population (entire) group, the sample variance deals with the average and deviation of extracted samples. In other words, it is calculated by extracting the sample average from each value of the data, and squaring each value, then adding them together and dividing them by the number of datas in the population group minus 1. This value is used to figure out the variance of the population group.

For more information, refer to `STDDEV_SAMP`.

## Example

```
gSQL> SELECT VAR_SAMP(c1) FROM t1;
```

```
VAR_SAMP(C1)
```

```
-----
```

```
132.2
```

```
1 row selected.
```



# 17.185 VARIANCE

## Syntax

```
VARIANCE( [ ALL | DISTINCT ] expr )
```

## Description

It is an aggregation function, and it obtains the variance of an expr set.

If ALL is specified, this function is performed for all values. If DISTINCT is specified, this function is performed for the values of which the duplicates were deleted from. If it is not specified, it is processed as if ALL is specified.

If the number of expr sets except for NULL after deleting the duplicates by using DISTINCT is one, then it returns 0.

The following table describes the arguments and result types.

**Table 17-32** Argument and result type of VARIANCE

expr	Result type
NATIVE_INTEGER family <ul style="list-style-type: none"> <li>NATIVE_SMALLINT</li> <li>NATIVE_INTEGER</li> <li>NATIVE_BIGINT</li> </ul>	NATIVE_DOUBLE
NUMBER	NUMBER
NATIVE_DOUBLE family <ul style="list-style-type: none"> <li>NATIVE_REAL</li> <li>NATIVE_DOUBLE</li> </ul>	NATIVE_DOUBLE



GOLDILOCKS gets the variance as follows.

- If the number of expr sets are 1, then it returns 0.
- If the number of expr sets are bigger than 1, It returns the value of **STDDEV\_SAMP (expr)**.

For more information, refer to **STDDEV**.

## Example

```
gSQL> SELECT VARIANCE(c1) FROM t1;
VARIANCE(C1)
-----
          132.2
1 row selected.
gSQL> SELECT VARIANCE(ALL c1) FROM t1;
VARIANCE(ALL C1)
-----
          132.2
1 row selected.
gSQL> SELECT VARIANCE(DISTINCT c1) FROM t1;
VARIANCE(DISTINCT C1)
-----
          176.25
1 row selected.
```

# 17.186 VERSION

## Syntax

VERSION()

## Description

It obtains the product's version string.

## Example

```
gSQL> SELECT VERSION() FROM dual;  
VERSION()
```

```
-----  
Release Name.X.X.X revision(XXXXX)
```

```
1 row selected.
```

## 17.187 WIDTH\_BUCKET

### Syntax

```
WIDTH_BUCKET( num, min, max, cnt )
```

### Description

It creates a section of the same width as `cnt` within a range between specified `min` and `max`, and it returns the section location in which the `num` is located.

The data type of `num` argument, `min` argument, `max` argument and `cnt` argument can be a numeric data type.

`min`, `max` means the range for the section. If the `min` value is equal to the `max` value, an error is returned. `cnt` means the number of sections. The `cnt` value should be a positive number. If the `cnt` value is 0 or a negative number, an error is returned.

The section's location is numbered from one.

If any of `num`, `min`, `max`, `cnt` is NULL, the result is also NULL.

### Example

```
gSQL> SELECT WIDTH_BUCKET( 5, 1, 20, 5 ) AS RESULT FROM DUAL;
RESULT
-----
      2
1 row selected.
```

**18.**

---

**SQL References (A~B)**

## 18.1 ALTER AUDIT POLICY

### Function

It adds an auditing target to an audit policy object, or drops an auditing target from an audit policy object.

### Syntax

```

<alter audit policy statement> ::=
    ALTER AUDIT POLICY policy_name
    { <add_audit_option> | <drop_audit_option> }
    ;
<add_audit_option> ::=
    ADD { <privilege_audit_clause> | <action_audit_clause> | <privilege_audit_clause>
<action_audit_clause> }
<drop_audit_option> ::=
    DROP { <privilege_audit_clause> | <action_audit_clause> | <privilege_audit_clause>
<action_audit_clause> }
<privilege_audit_clause> ::=
    PRIVILEGES <database_privilege> [, ...]
<action_audit_clause> ::=
    ACTIONS { <object_action_audit> | <system_action_audit> } [, ...]
<object_action_audit> ::=
    ALL ON [schema_name.]object_name
    | <object_action> ON [schema_name.]object_name
<system_action_audit> ::=
    ALL
    | <system_action>

```

### Invocation and Access Rules

AUDIT SYSTEM ON DATABASE privilege is required to perform <alter audit policy statement>.

## Syntax Rules and Parameters

### **policy\_name**

It is the name of an audit policy object to be altered.

### **<add\_audit\_option>**

It adds an auditing target to an audit policy.

### **<drop\_audit\_option>**

It drops an auditing target from an audit policy.

### **<privilege\_audit\_clause>**

For more information, refer to **CREATE AUDIT POLICY**.

### **<action\_audit\_clause>**

For more information, refer to **CREATE AUDIT POLICY**.

## Description

It can alter an audit policy which is already activated, and it does not effect the existing session but it effects only the newly created session.



When dropping ALL option as follows, not all actions are dropped, but only the corresponding ALL option is dropped.

```
CREATE AUDIT POLICY p1
  ACTIONS ALL ON u1.t1,
  SELECT ON u1.t1;
ALTER AUDIT POLICY p1 DROP
  ACTIONS ALL ON u1.t1;
```

## Examples

The following is an example of adding a new audit option to an audit policy.

```
ALTER AUDIT POLICY policy_dml  
    ADD ACTIONS SELECT ON u1.t1;
```

The following is an example of dropping an audit option from an audit policy.

```
ALTER AUDIT POLICY policy_dml  
    DROP ACTIONS SELECT ON u1.t1;
```

## Compatibility

The SQL standard does not have the audit policy.

## For More Information

Refer to the followings.

- Managing audit policy object
  - **CREATE AUDIT POLICY**
  - **DROP AUDIT POLICY**
  - **ALTER AUDIT POLICY**
- Activating/ deactivating audit policy
  - **AUDIT POLICY**
  - **NOAUDIT POLICY**
- Enquiring audit trail: **AUDIT\_TRAIL**
- Dropping audit trail: **ALTER DATABASE CLEAR AUDIT TRAIL**



## 18.2 ALTER CLUSTER GROUP name ADD MEMBER

### Function

It adds a cluster member to a cluster group.

### Syntax

```
<alter cluster group add member statement> ::=
    ALTER CLUSTER GROUP group_name ADD
        <cluster member definition> [, ...]
    ;
<cluster member definition> ::=
    CLUSTER MEMBER member_name <connection attribute> [<member position>]
<connection attribute> ::=
    HOST 'address' PORT port_no
<member position> ::=
    POSITION DEFAULT
    | POSITION MAX
    | POSITION number
```

### Invocation and Access Rules

It can be performed in a cluster system.

ADMINISTRATION ON DATABASE privilege is required to perform <alter cluster group add member statement>.

### Syntax Rules and Parameters

#### group\_name

It is the cluster group name.

## <cluster member definition>

It defines a cluster member to be included in a cluster group.

A cluster group may include maximum 32 cluster members.

### member\_name

It is the name of a cluster member.

The cluster member name should be as same as the member name which was defined when the database of that cluster member was created.

There should not be the same cluster group, nor the same cluster member.

The length of the name should be shorter than 128 bytes.

The start-up phase for the cluster member should be GLOBAL OPEN.

## <connection attribute>

It defines the connection information for the communication between the cluster members.

<connection attribute> should be as same as the HOST and PORT which were defined when the database of that cluster member was created.

The combination of HOST and PORT should be unique in the cluster system.

- HOST 'address' uses ip v4 type.
- PORT port\_no should be in the range between 1024 ~ 49151.

## <member position>

It assigns the position number of the cluster member.

- POSITION DEFAULT
  - The system automatically assigns the position number.
- POSITION MAX
  - It assigns the new member position number even when an empty position number exists.
  - It assigns the value bigger than the biggest member position.
- POSITION number
  - It assigns the position number corresponding to the number
  - The position number should be unique in the cluster system.
  - The position number should be an empty position number, and it should be same or smaller than the biggest position number.
- If it is omitted, the default value is POSITION DEFAULT.

The member\_position information of the cluster member can be retrieved through DBA\_CLUSTER view.

```
SELECT member_name, member_id, member_position FROM dba_cluster;
```

If the following position numbers are being used,

- G1N1: 0
- G1N2: 1
- G2N2: 3
- G3N2: 5

The following values are assigned according to each option.

- POSITION DEFAULT
  - It assigns 2 which is an empty value.
- POSITION MAX
  - It assigns 6 which is a value of a new position number.
- POSITION 3
  - It is duplicated, so it is an error.
- POSITION 4
  - It assigns 4 which is a position number.

## Description

<alter cluster group add member statement> statement does not rebalance shards in the tables. The following statement should be performed to rebalance shards on the added cluster member.

- ALTER DATABASE REBALANCE
- ALTER TABLE name REBALANCE

## Examples

The following is an example of adding two cluster members to a cluster group.

```
gSQL>  
ALTER CLUSTER GROUP g1 ADD  
  CLUSTER MEMBER g1n3 HOST '192.168.0.13' PORT 10130,  
  CLUSTER MEMBER g1n4 HOST '192.168.0.14' PORT 10140  
;
```

Cluster Group altered.

The following is an example of designating the empty member position as a cluster member position.

```
ALTER CLUSTER GROUP g2 ADD  
    CLUSTER MEMBER g2n1 HOST '192.168.0.21' PORT 10210 POSITION 4  
;
```

## Compatibility

The SQL standard does not define the concepts of the cluster.

## For More Information

Refer to the followings.

- **CREATE CLUSTER GROUP**
- **DROP CLUSTER GROUP**
- **ALTER DATABASE REBALANCE**
- **ALTER TABLE name REBALANCE**

## 18.3 ALTER CLUSTER GROUP name OFFLINE MEMBER

### Function

It sets a cluster member of the cluster group to offline.

### Syntax

```
<alter cluster group offline member statement> ::=  
    ALTER CLUSTER GROUP group_name OFFLINE CLUSTER MEMBER member_name  
    ;
```

### Invocation and Access Rules

It can be performed in a cluster system.

ADMINISTRATION ON DATABASE privilege is required to perform <alter cluster group offline member statement>.

### Syntax Rules and Parameters

#### group\_name

It is the cluster group name.

#### member\_name

It is the name of a cluster member.

The cluster member should be included in the cluster group of group\_name.

The cluster member should be inactive.

## Description

It sets the inactive cluster member to offline.

<alter cluster group offline member statement> statement does not rebalance shards in the tables.

## Examples

If trying to set the cluster member which is not inactive to offline, then the following error occurs.

```
gSQL>  
ALTER CLUSTER GROUP g1 OFFLINE CLUSTER MEMBER g1n2;  
ERR-42000(16417): active member 'G1N2' cannot be offlined
```

The following is an example of setting a specific cluster member to offline.

```
gSQL>  
ALTER CLUSTER GROUP g1 OFFLINE  
    CLUSTER MEMBER g1n3  
;  
Cluster Group altered.
```

## Compatibility

The SQL standard does not define the concepts of the cluster.

## For More Information

Refer to the followings.

- CREATE CLUSTER GROUP
- DROP CLUSTER GROUP
- ALTER DATABASE REBALANCE
- ALTER TABLE name REBALANCE

## 18.4 ALTER CLUSTER LOCATION

### Function

It alters a cluster location information.

### Syntax

```
<alter cluster location statement> ::=  
    ALTER CLUSTER LOCATION member_name  
    <cluster connection attribute>  
    ;  
<cluster connection attribute> ::  
    HOST 'address' PORT port_no
```

### Invocation and Access Rules

It can be performed in a cluster system.

ADMINISTRATION ON DATABASE privilege is required to perform <alter cluster location statement>.

### Syntax Rules and Parameters

#### member\_name

It is the name of a cluster member.

The same cluster member name should exist in the registered cluster location information.

The length of the name should be shorter than 128 bytes.

#### <cluster connection attribute>

It defines the connection information for the communication between the cluster members.

The combination of HOST and PORT should be unique in the cluster system.

- HOST 'address' uses ip v4 type.
- PORT port\_no should be in the range between 1024 ~ 49151.

## Description

If the connection information of the cluster location is altered, the cluster member does not need to be dropped or recreated, but the connection information can be altered by using **ALTER CLUSTER LOCATION**.

## Examples

```
gSQL>  
ALTER CLUSTER LOCATION g1n2  
    HOST '192.168.0.12' PORT 10120  
;  
altered.
```

## Compatibility

The SQL standard does not define the concepts of the cluster.

## For More Information

Refer to the followings.

- **CREATE CLUSTER LOCATION**
- **DROP CLUSTER LOCATION**



## 18.5 ALTER DATABASE ADD LOGFILE

### Function

It adds log file groups or log file members to the database.

### Syntax

```

<alter database add logfile statement> ::=
    <add logfile member statement>
  | <add logfile group statement>
  ;

<add logfile member statement> ::=
    ALTER DATABASE ADD LOGFILE MEMBER <add logfile clause> [, ...] TO
    <group clause>

<add logfile group statement> ::=
    ALTER DATABASE ADD LOGFILE <group clause> ( 'logfile_name' [, ...] )
    <size clause> [ REUSE ]

<group clause> ::=
    GROUP integer

<add logfile clause> ::=
    'logfile_name' [ REUSE ]

<size clause> ::=
    integer [ M | G ]
  
```

### Invocation and Access Rules

ALTER DATABASE ON DATABASE privilege is required to perform <alter database add logfile statement>.

### Syntax Rules and Parameters

## ⟨alter database add logfile statement⟩

The database should be in MOUNT phase.

## ⟨add logfile member statement⟩

The log member is added to an existing log file group.

- ⟨add logfile clause⟩
  - 'logfile\_name' is the file name of logfile member to be added to the log file group.
  - If the file does not exist, a new file is created.
  - The length of the logfile\_name should be shorter than 1024 bytes.
- ⟨group clause⟩
  - It specifies the identifier of the logfile group to be added to the database.
  - Integer should be an identifier of the existing logfile group.
  - If an identifier for the integer does not exist, an error occurs.

## ⟨add logfile group statement⟩

It adds a new log file group.

- It is added as the next group of the CURRENT log file group.
- ⟨group clause⟩
  - It specifies the identifier of the logfile group to be added to the database.
  - Integer should be an identifier of the unexisting logfile group.
  - If an identifier for the integer exists, an error occurs.
- ⟨size clause⟩
  - The file size can be specified minimum of 20 MB to maximum of 120 GB.
  - The file size should be bigger than the sum of redo log buffer size and pending log buffer size.
- When 'logfile\_name' already exists, and the REUSE option is used, if the file size is as same as another group member, then the existing log file is reused.

## Description

It is recommended to back up the control file just in case for the file damage because the newly added log file groups and log members are stored in the control file.

## Examples

The following is an example of adding two log file members to an existing log file group 3.

```
ALTER DATABASE ADD LOGFILE MEMBER 'logfile1.log', 'logfile2.log' TO GROUP 3;
```

The following is an example of adding a new log file group 4 to database. The size of log file group 4 is 100 M, and the log file name is 'logfile1.log'.

```
ALTER DATABASE ADD LOGFILE GROUP 4 ( 'logfile1.log' ) SIZE 100M;
```



When adding a log group, a single log file should be used, and multiple log files can be added to an existing group as a member.

## Compatibility

The SQL standard does not define ALTER DATABASE statement.

## For More Information

Refer to the followings.

- ALTER DATABASE ADD LOGFILE
- ALTER DATABASE DROP LOGFILE
- ALTER DATABASE RENAME LOGFILE

## 18.6 ALTER DATABASE ARCHIVELOG

### Function

It alters an archive setting of the online log file in the database.

### Syntax

```
<alter database archivelog statement> ::=  
    ALTER DATABASE { ARCHIVELOG | NOARCHIVELOG }  
    ;
```

### Invocation and Access Rules

ALTER DATABASE ON DATABASE privilege is required to perform <alter database archivelog statement>.

### Syntax Rules and Parameters

#### <alter database archivelog statement>

- The database should be in MOUNT phase.
- ARCHIVELOG
  - It archives the online log file.
- NOARCHIVELOG
  - It does not archive the online log file.

### Description

For the database backup and the media recovery using the backup, the system should be operated in ARCHIVELOG mode.

## Example

The following is an example of how to set up a database to archive mode.

```
ALTER DATABASE ARCHIVELOG;
```

## Compatibility

The SQL standard does not define ALTER DATABASE statement.

## For More Information

Refer to the followings.

- ALTER DATABASE BACKUP
- ALTER TABLESPACE name BACKUP

## 18.7 ALTER DATABASE BACKUP

### Function

The backup state is set to ACTIVE or INACTIVE to perform a full backup of the database. Then, the incremental database backup and control file backup are performed.

### Syntax

```

<alter database backup statement> ::=
    <database begin backup statement>
  | <database end backup statement>
  | <database incremental backup statement>
  | <database controlfile backup statement>
  ;
<database begin backup statement> ::=
    ALTER DATABASE BEGIN BACKUP [ AT <domain name> ]
  ;
<database end backup statement> ::=
    ALTER DATABASE END BACKUP [ AT <domain name> ]
  ;
<database incremental backup statement> ::=
    ALTER DATABASE BACKUP INCREMENTAL
      <incremental backup option> [ AT <domain name> ]    ;
<incremental backup option> ::=
    LEVEL integer [ CUMULATIVE | DIFFERENTIAL ]
<database controlfile backup statement> ::=
    ALTER DATABASE BACKUP CONTROLFILE TO 'target_name'
      [ AT <domain name> ]    ;

```

### Invocation and Access Rules

ALTER DATABASE ON DATABASE privilege is required to perform <alter database backup statement>.

## Syntax Rules and Parameters

### <database begin backup clause>

The database is set to the state which the full backup is available.

- All tablespaces in ONLINE state, which is created and used in the database, are set to the state of which the full backup is available.
- The database should be OPEN state and operated in ARCHIVELOG mode.
- After starting BEGIN BACKUP, the following operations which require writing to the data file can not be performed.
  - SHUTDOWN NORMAL
  - OFFLINE / DROP TABLESPACE
  - ADD / DROP DATAFILE
- It may require media recovery on restart when a full backup is ACTIVE state and the instance is abnormally terminated.

### <database end backup clause>

The database is set to the state which the full backup is not available.

- All tablespaces in ONLINE state, which is created and used in the database, are set to the state which the full backup is not available.
- The database should be in OPEN phase and operated in ARCHIVELOG mode.

### <database incremental backup statement>

- An incremental backup is performed for the database.
- The database should be in OPEN phase and operated in ARCHIVELOG mode.

### <incremental backup option>

- 'integer' can be specified from 0 to 4.
- LEVEL 0 can not specify CUMULATIVE or DIFFERENTIAL.
- CUMULATIVE | DIFFERENTIAL
  - CUMULATIVE
    - If 'integer' is n, it backs up all pages which are altered after the most recent backups of LEVEL 0 ~ LEVEL n-1.
  - DIFFERENTIAL
    - If 'integer' is n, it backs up all pages which are altered after the most recent backups of LEVEL 0 ~ LEVEL n.

- If it is omitted, DIFFERENTIAL is specified by default.

## <database controlfile backup statement>

- The control file is backed up.
  - The length of 'target\_name' should be shorter than 1024 bytes.
  - If 'target\_name' already exists, the operation fails.
- The database should be in OPEN phase and operated in ARCHIVELOG mode.



The maximum length of the 'target\_name' managed by GOLDILOCKS is 1024 bytes. However, the maximum lengths of the file name varies depending on the OS, so the actual length of 'target\_name' which is available to be created can be shorter than 1024 bytes.

## <domain name>

It is a name of a member or a group for which the statement is performed.

If it is omitted, it is performed for all groups.

## Description

It backs up data files and control files in the database. A full backup of the database begins with BEGIN BACKUP, and copies the datafiles using OS file copy, then ends with END BACKUP. The incremental backup file is created in the path set by the BACKUP\_DIR 1 property using a single statement.

## Examples

The following is an example to set the entire backup state to ACTIVE.

```
ALTER SYSTEM BEGIN BACKUP;
```

The following is an example to set the entire backup state to INACTIVE.

```
ALTER SYSTEM END BACKUP;
```

The following is an example to create the incremental backup of LEVEL 1 by using DIFFERENTIAL.



```
ALTER DATABASE BACKUP INCREMENTAL LEVEL 1 DIFFERENTIAL;
```

The following is an example to create the 'controlfile.bak' backup file for the control file. If the absolute path is not included, a backup file is created in the path set by the LOG\_DIR property.

```
ALTER DATABASE BACKUP CONTROLFILE TO 'controlfile.bak';
```

## Compatibility

The SQL standard does not define ALTER DATABASE statement.

## For More Information

Refer to the followings.

- ALTER TABLESPACE name BACKUP
- ALTER DATABASE RECOVER

## 18.8 ALTER DATABASE CLEAR AUDIT TRAIL

### Function

It purges audit records which are accumulated when applying an audit policy.

### Syntax

```
<clear audit trail statement> ::=  
    ALTER DATABASE CLEAR AUDIT TRAIL  
    ;
```

### Invocation and Access Rules

AUDIT SYSTEM ON DATABASE privilege is required to perform <clear audit trail statement>.

### Description

If an audit policy is activated, an audit trails is getting longer as time goes by.

Tables configuring an audit trail are stored in MEM\_AUX\_TBS tablespace, and a user should be cautious not to let the audit trail keep increasing.

### Storing Audit Trail

A user should purge an audit trail after storing it according to the following procedure to store an audit trail when it is necessary.

- When performing it for the first time

```
CREATE TABLE backup_audit_trail AS SELECT * FROM AUDIT_TRAIL;  
COMMIT;
```

- When repeatedly performing it

```
INSERT INTO backup_audit_trail SELECT * FROM AUDIT_TRAIL;  
COMMIT;
```

- When purging an audit trail

```
ALTER DATABASE CLEAR AUDIT TRAIL;
```

## Examples

Purge an audit trail by using the following statement.

```
ALTER DATABASE CLEAR AUDIT TRAIL;
```

## Compatibility

The SQL standard does not have the audit policy.

## For More Information

Refer to the followings.

- Managing audit policy object
  - **CREATE AUDIT POLICY**
  - **DROP AUDIT POLICY**
  - **ALTER AUDIT POLICY**
- Activating/ deactivating audit policy
  - **AUDIT POLICY**
  - **NOAUDIT POLICY**
- Enquiring audit trail: **AUDIT\_TRAIL**
- Dropping audit trail: **ALTER DATABASE CLEAR AUDIT TRAIL**

## 18.9 ALTER DATABASE CLEAR PASSWORD HISTORY

### Function

It deletes the user's password change history which is accumulated due by applying the profile.

### Syntax

```
<clear password history statement> ::=
    ALTER DATABASE CLEAR PASSWORD HISTORY
    ;
```

### Invocation and Access Rules

ALTER DATABASE ON DATABASE privilege is required to perform <clear password history statement>.

### Description

When a profile is applied to a user, the user's password change history is accumulated according to the PASSWORD\_REUSE\_MAX, PASSWORD\_REUSE\_TIME policy.

**Table 18-1** Managing the change history

PASSWORD_REUSE_MAX	PASSWORD_REUSE_TIME	Managing the change history
value	value	It manages only the change history within the value range, and the change history out of the value range is automatically deleted.
value	UNLIMITED	It accumulates all change history and it does not delete any change history because all change history should be checked.
UNLIMITED	value	It accumulates all change history and it does not delete any change history because all change history should be checked.
UNLIMITED	UNLIMITED	It does not manage the change history because the change history is not checked.

⟨Clear password history statement⟩ deletes the accumulated user's password change history.

## Examples

The following is an example of executing ⟨clear password history statement⟩ statement.

```
gSQL> ALTER DATABASE CLEAR PASSWORD HISTORY;  
Database altered.  
gSQL> COMMIT;  
Commit complete.
```

## Compatibility

The SQL standard does not define ALTER DATABASE statement.

## For More Information

Refer to the followings.

- CREATE PROFILE
- CREATE USER

## 18.10 ALTER DATABASE DATAFILE AUTOEXTEND

### Function

It alters the property to automatically extend disk tablespace data file. If the property is ON, then the size to be extended and the maximum size of the data file also can be altered.

### Syntax

```

<alter database datafile autoextend statement> ::=
    ALTER DATABASE DATAFILE datafile_name <autoextend clause>
        [ AT <domain name> ]
    ;
<autoextend clause>
    AUTOEXTEND { ON [ <next size clause> ] [ <max size clause> ] | OFF }
<next size clause>
    NEXT <size clause>
<max size clause>
    MAXSIZE { <size clause> | UNLIMITED }
  
```

### Invocation and Access Rules

ALTER DATABASE ON DATABASE privilege is required to perform <alter database datafile autoextend statement>

The datafile automatic expand property can alter the property of disk tablespace only.

#### datafile\_name

It specifies the name of the data file to be altered.

#### <autoextend clause>

It sets the automatic expand property to ON or OFF. If it is set to ON, then it can specify the automatic expanded size and the maximum size of the data file.

## ⟨next size clause⟩

It specifies the size to be extended when the data file in use does not have available space.

## ⟨max size clause⟩

It specifies the maximum expanded size of the data file.

## Description

Refer to the syntax rules of each statement.

## Examples

The following is an example of altering the automatic expand property of the datafile, the automatic expanded size, and datafile size.

```
gSQL> ALTER DATABASE DATAFILE 'DISK_TBS.dbf' AUTOEXTEND OFF;
Database altered.
gSQL> ALTER DATABASE DATAFILE 'DISK_TBS.dbf' AUTOEXTEND ON;
Database altered.
gSQL> ALTER DATABASE DATAFILE 'DISK_TBS.dbf' AUTOEXTEND ON NEXT 20M;
Database altered.
gSQL> ALTER DATABASE DATAFILE 'DISK_TBS.dbf' AUTOEXTEND ON MAXSIZE 1G;
Database altered.
gSQL> ALTER DATABASE DATAFILE 'DISK_TBS.dbf' AUTOEXTEND ON 20M MAXSIZE 1G;
Database altered.
```

## Compatibility

The SQL standard does not define the concepts of the datafile.

## For More Information

Refer to `CREATE DISK DATA TABLESPACE`.



## 18.11 ALTER DATABASE DELETE BACKUP

### Function

It deletes the backup file and the backup information of incremental backup. It can delete all incremental backup of the database or no longer usable obsolete backup.

### Syntax

```

<alter database delete backup statement> ::=
    ALTER DATABASE DELETE <delete backup list option>
        BACKUP LIST [ <including backup file option> ]
    ;
<delete backup list option> ::=
    OBSOLETE
    | ALL
<including backup file option> ::=
    INCLUDING BACKUP FILES
  
```

### Invocation and Access Rules

ALTER DATABASE ON DATABASE privilege is required to perform <alter database delete backup statement>.

### Syntax Rules and Parameters

#### <alter database delete backup statement>

The database should be in MOUNT or OPEN phase.

## <delete backup list option>

It selects the backups to be deleted among the existing incremental backups.

- **OBSOLETE:** It selects backups of database or tablespaces to be deleted, which was backed up before the most recent database LEVEL 0 backup.
- **ALL:** It selects all incremental backups to be deleted.

## <including backup file option>

- If it is omitted, it deletes only the backup information from the control file.
- It also deletes not only backup information but also the backup files.

## Description

Deletion of the OBSOLETE incremental backup deletes the incremental backup of which is before the most recent LEVEL 0 database backup. When non-LEVEL 0 incremental backup is performed, it is not deleted even if it includes the previously performed incremental backup. It is because it can be used when performing the incomplete recovery by using the incremental backups.



Be cautious of deleting the backup file together when an incremental backup is deleted. It can not be recovered even by using the control file which has incremental backup information.

## Example

The following is an example to delete the backup information and backup files of all existing incremental backups.

```
ALTER DATABASE DELETE ALL BACKUP LIST INCLUDING BACKUP FILES;
```

## Compatibility

The SQL standard does not define ALTER DATABASE statement.

## For More Information

Refer to the followings.

- ALTER TABLESPACE name BACKUP
- ALTER DATABASE RECOVER

## 18.12 ALTER DATABASE DROP INACTIVE CLUSTER MEMBERS

### Function

It drops the entire inactive cluster member.

### Syntax

```
<alter database drop inactive members statement> ::=  
    ALTER DATABASE DROP [ FORCE | NO FORCE ] INACTIVE CLUSTER MEMBERS  
    ;
```

### Invocation and Access Rules

It can be performed in a cluster system.

ADMINISTRATION ON DATABASE privilege is required to perform <alter database drop inactive cluster members statement>.

### Syntax Rules and Parameters

#### [ FORCE | NO FORCE ]

- FORCE
  - It drops an inactive cluster member even when there is a possibility of data loss.
- NO FORCE
  - It can not drop an inactive cluster member if there is a possibility of data loss.
- The default value is NO FORCE.

## Description

It drops the entire inactive cluster member.

The inactive state of a cluster member means that it is not connected to the cluster system, and it occurs in the following cases.

- An error occurs on a cluster member in an operating cluster system.
- Trying to start-up the cluster system without driving the cluster member.

However, if the table shard is lost while dropping the cluster member, then an inactive cluster member can not be dropped.

Also, if there is a possibility of data loss when dropping the cluster member, then an inactive cluster member can not be dropped. The data is not lost when it is guaranteed that the data in replica of the table or the shard which belongs to the inactive cluster member to be dropped is not latest comparing to that in the members of that cluster group. Therefore, an inactive cluster member can be dropped when at least one online member exists in the same cluster group in case for the sharded table, and in the entire cluster in case for the cloned table.

However, if an online cluster member does not exist in the cluster group and the service is not available due to an inactive cluster member, then the inactive cluster member can be dropped by using FORCE option despite of the possibility of the data loss.

It is recommended to use `<alter database drop inactive members statement>` when an inactive cluster member can not be included in the cluster system any more.

## Examples

The following is an example of executing `<alter database drop inactive members statement>`.

```
gSQL> ALTER DATABASE DROP INACTIVE CLUSTER MEMBERS;  
Database altered.
```

## Compatibility

The SQL standard does not define the concepts of the cluster.

## For More Information

Refer to **ALTER SYSTEM JOIN DATABASE**.

## 18.13 ALTER DATABASE DROP LOGFILE

### Function

It drops a log file group or a member which exists in the database.

### Syntax

```

<alter database drop logfile statement> ::=
    <drop logfile group statement>
  | <drop logfile member statement>
  ;
<drop logfile group statement> ::=
    ALTER DATABASE DROP LOGFILE <group clause>
<group clause> ::=
    GROUP integer
<drop logfile member statement> ::=
    ALTER DATABASE DROP LOGFILE MEMBER <logfile_list>
<logfile_list> ::=
    'logfile_name'
  | <logfile_list> , 'logfile_name'

```

### Invocation and Access Rules

ALTER DATABASE ON DATABASE privilege is required to perform <alter database drop logfile statement>.

### Syntax Rules and Parameters

#### <alter database drop logfile statement>

The database should be in MOUNT phase.

An error occurs when the log file to be deleted is in CURRENT or ACTIVE stage.

At least four log file groups should be remained after dropping.

## <drop logfile group statement>

It drops the existing log file group.

- <group clause>
  - It specifies the log file group to be dropped.
  - An integer should be an identifier of the existing log file.
  - An error occurs if the integer does not exist.

## <drop logfile member statement>

It drops the existing log file members.

- <logfile\_list>
  - It is the list of the log file members to be dropped.
  - 'logfile\_name' should be an existing name.
  - An error occurs if 'logfile\_name' does not exist.

## Description

For more information, refer to the rules for each syntax.

## Examples

The following is an example of dropping the existing log file GROUP 3.

```
ALTER DATABASE DROP LOGFILE GROUP 3;
```

The following is an example of dropping logfile1.log and logfile2.log from the existing logfile GROUP 3.

```
ALTER DATABASE DROP LOGFILE MEMBER 'logfile1.log', 'logfile2.log';
```

## Compatibility

The SQL standard does not define ALTER DATABASE statement.



## For More Information

Refer to the respective syntax rules, and the followings.

- ALTER DATABASE ADD LOGFILE
- ALTER DATABASE RENAME LOGFILE

## 18.14 ALTER DATABASE MOVE SHARD

### Function

It rebalances shard of all tables in a specific cluster group to another cluster group.

### Syntax

```
<alter database move shard statement> ::=  
    ALTER DATABASE MOVE SHARD FROM CLUSTER GROUP src_cluster_group  
    TO CLUSTER GROUP dest_cluster_group [ ONLINE | OFFLINE ];
```

### Invocation and Access Rules

It can be performed in a cluster system.

ALTER DATABASE ON DATABASE privilege is required to perform <alter database move shard statement>.

### Syntax Rules and Parameters

#### src\_cluster\_group

It is a cluster group to which the table shard is moved.

#### dest\_cluster\_group

It is a target cluster group to which the table shard is moved.

#### [ ONLINE | OFFLINE ]

It determines whether to allow DML when rebalancing table shard.

- ONLINE
  - It allows INSERT, UPDATE, and DELETE.

- OFFLINE
  - It does not allow INSERT, UPDATE, DELETE.
- When it is omitted, the default value is ONLINE.

## Description

When adding a cluster member and a cluster group using the following statements, the table shard is not rebalanced.

- CREATE CLUSTER GROUP
- ALTER CLUSTER GROUP name ADD MEMBER

Perform <alter database rebalance statement> to rebalance the shard of the entire table which was not rebalanced when adding a cluster group and a cluster member.

<alter database move shard statement> is performed as the following concepts for tables which did not rebalance the shard.

```
ALTER TABLE t1 MOVE SHARD FROM CLUSTER GROUP src_group TO CLUSTER GROUP dest_group;
COMMIT;
ALTER TABLE t2 MOVE SHARD FROM CLUSTER GROUP src_group TO CLUSTER GROUP dest_group;
COMMIT;
ALTER TABLE t3 MOVE SHARD FROM CLUSTER GROUP src_group TO CLUSTER GROUP dest_group;
COMMIT;
...
...
ALTER TABLE t_n MOVE SHARD FROM CLUSTER GROUP src_group TO CLUSTER GROUP dest_group;
COMMIT;
```

It is performed as above for all tables except for a CLONED table and a CLUSTER WIDE table. The <alter database move shard statement> is proceeded even when the rebalancing the shard of a specific table fails. It does not rollback the table which succeeded in rebalancing the shard.

Therefore, when performing <alter database move shard statement> again after appropriately processed an error, then it rebalances only the shard for the table requiring the rebalancing. In this case, the table which succeeded in rebalancing the shard is not included in a target of the rebalancing.

## Examples

The following is an example of performing <alter database move shard statement>.

```
gSQL> ALTER DATABASE MOVE SHARD FROM CLUSTER GROUP G1 TO CLUSTER GROUP G2;  
Database altered.
```

## Compatibility

The SQL standard does not define the concepts of the cluster.

## For More Information

Refer to the followings.

- **ALTER TABLE name MOVE SHARD**
- **CREATE CLUSTER GROUP**
- **ALTER CLUSTER GROUP name ADD MEMBER**

# 18.15 ALTER DATABASE OFFLINE INACTIVE CLUSTER MEMBERS

## Function

It sets the entire inactive cluster member to offline. In other words, it sets the shard map for the cluster member to offline.

## Syntax

```
⟨alter database offline inactive cluster members statement⟩ ::=  
    ALTER DATABASE OFFLINE INACTIVE CLUSTER MEMBERS  
    ;
```

## Invocation and Access Rules

It can be performed in a cluster system.

ADMINISTRATION ON DATABASE privilege is required to perform ⟨alter database offline inactive cluster members statement⟩.

## Syntax Rules and Parameters

It sets the entire inactive cluster member to offline.

The inactive state of a cluster member means that it is not connected to the cluster system, and it occurs in the following cases.

- An error occurs on a cluster member in an operating cluster system.
- Trying to start-up the cluster system without driving the cluster member.

## Description

It is recommended to use `<alter database offline inactive members statement>` when an inactive cluster member can not be included in the cluster system any more.

If an inactive cluster member can participate in a cluster system, then perform **ALTER SYSTEM JOIN DATABASE** to include it in a cluster system.

The cluster member which is set to offline can be shifted to online again by using the following statements after the join.

- **ALTER DATABASE REBALANCE**
- **ALTER TABLE name REBALANCE**

## Examples

```
gSQL> ALTER DATABASE OFFLINE INACTIVE CLUSTER MEMBERS;
```

## Compatibility

The SQL standard does not define the concepts of the cluster.

## For More Information

Refer to the followings.

- **ALTER SYSTEM JOIN DATABASE**
- **ALTER DATABASE REBALANCE**
- **ALTER TABLE name REBALANCE**

## 18.16 ALTER DATABASE REBALANCE

### Function

It rebalances shard of all tables.

### Syntax

```
<alter database rebalance statement> ::=  
    ALTER DATABASE REBALANCE [ ONLINE | OFFLINE ];
```

### Invocation and Access Rules

It can be performed in a cluster system.

ALTER DATABASE ON DATABASE privilege is required to perform <alter database rebalance statement>.

### Syntax Rules and Parameters

#### [ ONLINE | OFFLINE ]

It determines whether to allow DML when rebalancing table shard.

- ONLINE
  - It allows INSERT, UPDATE, and DELETE.
- OFFLINE
  - It does not allow INSERT, UPDATE, DELETE.
- When it is omitted, the default value is ONLINE.

## Description

When adding a cluster member and a cluster group using the following statements, the table shard is not rebalanced.

- **CREATE CLUSTER GROUP**
- **ALTER CLUSTER GROUP name ADD MEMBER**

Perform `<alter database rebalance statement>` to rebalance the shard of the entire table which was not rebalanced when adding a cluster group and a cluster member.

`<alter database rebalance statement>` is performed as the following concepts for tables which did not rebalance the shard.

```
ALTER TABLE t1 REBALANCE;  
COMMIT;  
ALTER TABLE t2 REBALANCE;  
COMMIT;  
ALTER TABLE t3 REBALANCE;  
COMMIT;  
...  
...  
ALTER TABLE t_n REBALANCE;  
COMMIT;
```

The `<alter database rebalance statement>` is proceeded even when the rebalancing the shard of a specific table fails. It does not rollback the table which succeeded in rebalancing the shard.

Therefore, when performing `<alter database rebalance statement>` again after appropriately processed an error, then it rebalances only the shard for the table requiring the rebalancing. In this case, the table which succeeded in rebalancing the shard is not included in a target of the rebalancing.

## Examples

The following is an example of performing `<alter database rebalance statement>`.

```
gSQL> ALTER DATABASE REBALANCE;  
Database altered.
```



## Compatibility

The SQL standard does not define the concepts of the cluster.

## For More Information

Refer to `ALTER TABLE name REBALANCE`.

# 18.17 ALTER DATABASE REBALANCE EXCLUDE CLUSTER GROUP

## Function

It rebalances shard of all tables excluding shards of a specific cluster group.

## Syntax

```
<alter database rebalance exclude cluster group statement> ::=  
    ALTER DATABASE REBALANCE EXCLUDE CLUSTER GROUP cluster_group_name [ ONLINE | OFFLINE ];
```

## Invocation and Access Rules

It can be performed in a cluster system.

ALTER DATABASE ON DATABASE privilege is required to perform <alter database rebalance exclude cluster group statement>.

## Syntax Rules and Parameters

### cluster\_group\_name

It is a name of the cluster group excluding a shard of the table.

If the specified cluster group is the only cluster group, then the statement can not be performed.

### [ ONLINE | OFFLINE ]

It determines whether to allow DML when rebalancing table shard.

- ONLINE
  - It allows INSERT, UPDATE, and DELETE.
- OFFLINE

- It does not allow INSERT, UPDATE, DELETE.
- When it is omitted, the default value is ONLINE.

## Description

To drop a cluster group by using **DROP CLUSTER GROUP**, there should not be a shard in the cluster group.

Perform `<alter database rebalance exclude cluster group statement>` to exclude a shard from the cluster group. `<alter database rebalance exclude cluster group statement>` is performed as the following concepts for tables which include a shard in the cluster group.

```
ALTER TABLE t1 REBALANCE EXCLUDE CLUSTER GROUP g3;
COMMIT;
ALTER TABLE t2 REBALANCE EXCLUDE CLUSTER GROUP g3;
COMMIT;
ALTER TABLE t3 REBALANCE EXCLUDE CLUSTER GROUP g3;
COMMIT;
...
...
ALTER TABLE t_n REBALANCE EXCLUDE CLUSTER GROUP g3;
COMMIT;
```

If the `<alter database rebalance exclude cluster group statement>` fails due to the lack of storage space, it does not rollback the table which succeed in excluding a shard.

Therefore, when performing `<alter database rebalance exclude cluster group statement>` again after appropriately processed an error, then it excludes and rebalances only the shard for the table requiring the rebalancing. In this case, the table which succeeded in excluding the shard is not included in a target of the rebalancing.

## Examples

The following is an example of performing `<alter database rebalance exclude cluster group statement>`.

```
gSQL> ALTER DATABASE REBALANCE EXCLUDE CLUSTER GROUP g3;
Database altered.
```

## Compatibility

The SQL standard does not define the concepts of the cluster.

## For More Information

Refer to the followings.

- **DROP CLUSTER GROUP**
- **ALTER TABLE name REBALANCE EXCLUDE CLUSTER GROUP cluster\_group\_list**

## 18.18 ALTER DATABASE RECOVER

### Function

It recovers the entire data file or part of the data files in the database by using the online and archive log files.

### Syntax

```

<alter database recover statement> ::=
    <complete database recover statement>
  | <datafile recover statement>
  | <complete tablespace recover statement>
  | <incomplete database recover statement>
  ;

<complete database recover statement> ::=
    ALTER DATABASE RECOVER

<datafile recover statement> ::=
    ALTER DATABASE RECOVER DATAFILE <datafile recovery clause>

<datafile recovery clause> ::=
    <datafile recovery object> [, ...]

<datafile recovery object> ::=
    'datafile_name' [<recovery using backup option>] [recovery corruption option]

<recovery using backup option> ::=
    USING BACKUP 'backup_datafile_name'

<recovery corruption option> ::=
    CORRUPTION

<complete tablespace recover statement> ::=
    ALTER DATABASE RECOVER TABLESPACE tablespace_name

<incomplete database recover statement> ::=
    <batch incomplete recovery statement>
  | <interactive incomplete recovery statement>
  ;

<batch incomplete recovery statement> ::=
    ALTER DATABASE RECOVER <until clause> [<using backup controlfile option>]

<until clause> ::=

```

```

        UNTIL CHANGE integer
<using backup controlfile option> ::=
        USING BACKUP CONTROLFILE
<interactive incomplete recovery statement> ::=
        ALTER DATABASE <incomplete recovery option> [<using backup controlfile option>]
<incomplete recovery option> ::=
        BEGIN INCOMPLETE RECOVERY
        | END INCOMPLETE RECOVERY
        | RECOVER 'logfile name'
        | RECOVER AUTOMATICALLY
        | RECOVER SUGGESTION
        ;

```

## Invocation and Access Rules

ALTER DATABASE ON DATABASE privilege is required to perform <alter database recover statement>.

## Syntax Rules and Parameters

### <complete database recover statement>

The data files of the database are recovered up to date by using the online and archive log files.

- The recovery is performed for all tablespaces in the ONLINE state.
- The database should be in MOUNT phase and in ARCHIVELOG mode.
- If the required archived log file does not exist, it fails.

### <datafile recover statement>

It recovers the backedup datafile, the datafile of the tablespace which requires the recovery by using the archive logfile due to an error during the backup, or the datafile of the tablespace which was set to offline by an immediate option, to the latest status.

- Datafile can be recovered on MOUNT phase or OPEN phase.
- The datafile of the tablespace which is in OFFLINE state can be recovered on OPEN phase, and datafile which is either in ONLINE/OFFLINE state can be recovered in MOUNT phase.
- If the required archive logfile does not exist, then the recovery fails.
- <datafile recovery clause>
  - It specifies one or more datafile object list which is a target of the recovery.

- <datafile recovery object>
  - It sets the name of datafile which is a target of the recovery, and the recovery option.
- <recovery using backup option>
  - It sets the name of backup datafile of the datafile which is a target of the recovery.
- <recovery corruption option>
  - It determines whether to recover only the pages corrupted from the datafile which is a target of the recovery.

## <complete tablespace recover statement>

The data files of the tablespace is recovered up to date.

- Tablespace recovery should be performed when the database is in MOUNT or OPEN phase.
- The recovery in the OPEN phase can only be performed when the tablespaces is in the OFFLINE stage, and the recovery in MOUNT phase can be performed when the tablespace is either in ONLINE/ OFFLINE stage.
- If the required archive log file does not exist, it fails.
- The following is the case which requires the tablespace recovery operation.
  - The tablespace became OFFLINE by IMMEDIATE.
  - The backed up data file is used.
  - A failure occurred during the entire backup.

## <incomplete database recover statement>

### <batch incomplete database recover statement>

The datafiles in the database are recovered in a batch up to a specific point of time by using the online and archive logfile.

- The recovery is performed for all tablespaces in the ONLINE stage.
- The database should be in MOUNT phase and in ARCHIVELOG mode.
- It fails if using the data file containing data which is after the time of the incomplete recovery.
- The database should be OPEN by using RESETLOGS after completion of incomplete recovery.
- <until clause>
  - A specific point of time for incomplete recovery
  - UNTIL CHANGE: The point of time is specified for incomplete recovery in log units
- <using backup controlfile>
  - Deprecated

## ⟨interactive incomplete database recover statement⟩

The data files in the database are interactively recovered with a user up to a specific point of time by using online and archive log file.

- The recovery is performed for all tablespaces in the ONLINE stage.
- The database should be in MOUNT phase and in ARCHIVELOG mode.
- It fails if using the data file containing data which is after the time of the incomplete recovery.
- The database should be OPEN by using RESETLOGS after completion of incomplete recovery.
- ⟨incomplete recovery option⟩
  - It is an option to perform an interactive incomplete recovery in log units.
  - BEGIN INCOMPLETE RECOVERY: It starts an incomplete recovery.
  - END INCOMPLETE RECOVERY: It ends an incomplete recovery.
  - RECOVER 'logfile name': A user directly specifies the log file performing the recovery.
  - RECOVER AUTOMATICALLY: All recoverable archive log files are recovered.
  - RECOVER SUGGESTION: It recovers archive log files which are required for the recovery and recommended by the system.
- ⟨using backup controlfile⟩
  - Deprecated.

## Description

Incomplete recovery of the database is not easy to find a recovery completion point at a time. Therefore, the desired recovery point is found by performing it several times.

However, it becomes a new database if the database is started up with RESETLOGS option after an incomplete recovery. Therefore, the incomplete recovery should be performed several times after creating a copy of the archived log files and online redo log files.

## Examples

The following is an example of a complete recovery for entire database.

```
ALTER DATABASE RECOVER;
```

The following is an example of a datafile recovery.

```
ALTER DATABASE RECOVER DATAFILE 'test.dbf';
```

The following is an example of a tablespace recovery.



```
ALTER DATABASE RECOVER TABLESPACE test_tbs;
```

The following is an example of incomplete recovery for the entire database until LSN is 11123.

```
ALTER DATABASE RECOVER UNTIL CHANGE 11123;
```

The following is an example of interactive incomplete recovery until the recoverable archive log files.

```
ALTER DATABASE BEGIN INCOMPLETE RECOVERY;  
ALTER DATABASE RECOVER AUTOMATICALLY;  
ALTER DATABASE END INCOMPLETE RECOVERY;
```

## Compatibility

The SQL standard does not define ALTER DATABASE statement.

## For More Information

Refer to the followings.

- ALTER DATABASE BACKUP
- ALTER TABLESPACE name BACKUP
- ALTER SYSTEM {MOUNT | OPEN} DATABASE

## 18.19 ALTER DATABASE REGISTER

### Function

It registers unrecoverable segments in the database.

### Syntax

```
<alter database register statement> ::=  
    ALTER DATABASE REGISTER IRRECOVERALBE SEGMENT  
        <segment physical identifier list>  
    ;  
<segment physical identifier list> ::=  
    integer  
    | <segment physical identifier list> , integer
```

### Invocation and Access Rules

ALTER DATABASE ON DATABASE privilege is required to perform <alter database register statement>.

### Syntax Rules and Parameters

#### <alter database register statement>

It registers the unrecoverable segments in the database. The statement can be used on the assumption that the segment is not used any more, when the database is not recoverable and the backup does not exist.

- The database should be in MOUNT phase.
- The registered segment identifier list is initialized at restart.
- If a server restart is successful, the registered segment becomes 'UNUSABLE' state, and that segments should be deleted.

## <segment physical identifier list>

The list of unrecoverable segment identifier

- Integer: 8 bytes integer segment identifier

## Description

When a server restarts after abnormal termination, the database performs the recovery process. During this process, it executes pages again by using the REDO log to recover pages which was not reflected in the disk in the previous service stage.

If an unexpected failure occurs during execution of the REDO operation, that statement can be used to ignore the failure and to execute the recovery.

## Example

The following is an example of giving up the recovery of the segment whose identifier is 4028679323648.

```
ALTER DATABASE REGISTER IRRECOVERABLE SEGMENT 4028679323648;
```

## Compatibility

The SQL standard does not define ALTER DATABASE statement.

## For More Information

Refer to the followings.

- ALTER TABLESPACE name BACKUP
- ALTER DATABASE RECOVER

## 18.20 ALTER DATABASE RENAME LOGFILE

### Function

It renames the logfile in the database.

### Syntax

```
<alter database rename logfile statement> ::=  
    ALTER DATABASE RENAME LOGFILE <logfile_list> TO <logfile_list>  
    ;  
<logfile_list> ::=  
    'logfile_name'  
    | <logfile_list> , 'logfile_name'
```

### Invocation and Access Rules

ALTER DATABASE ON DATABASE privilege is required for performing <alter database rename logfile statement>.

### Syntax Rules and Parameters

#### <alter database rename logfile statement>

- The database should be in MOUNT phase.
- FROM <logfile\_list>
  - The name list of the logfiles to modify in the database.
- TO <logfile\_list>
  - The name list of the logfiles to be modified in the database.
  - <logfile\_list> should be an existing file.
  - An error occurs if the file does not exist.

## Description

For more information, refer to the rules for each syntax.

## Example

The following is an example of modifying the existing 'logfile.log' logfile to 'newlogfile.log'.

```
ALTER DATABASE RENAME LOGFILE 'logfile.log' TO 'newlogfile.log';
```

## Compatibility

The SQL standard does not define ALTER DATABASE statement.

## For More Information

Refer to the followings.

- ALTER DATABASE ADD LOGFILE
- ALTER DATABASE DROP LOGFILE

# 18.21 ALTER DATABASE RESET LOCAL CLUSTER MEMBER

## Function

It resets the local cluster member except for the tablespace object to the time of creating the database.

## Syntax

```
<alter database reset local cluster member statement> ::=  
    ALTER DATABASE RESET LOCAL CLUSTER MEMBER  
    ;
```

## Invocation and Access Rules

It can be performed in a cluster system.

The start-up phase should be LOCAL OPEN.

ADMINISTRATION ON DATABASE privilege is required to perform <alter database reset local cluster member statement>.

## Description

It resets the local cluster member except for the tablespace object to the time of creating the database. It drops all objects created by a user except for the tablespace object.

<alter database reset local cluster member statement> statement resets an inactive cluster member, and makes the new cluster member to participate in a cluster system.

An inactive cluster member which is disconnected from the cluster system is processed as follows.

- If it can join in a cluster system again, then use JOIN statement to make it join.
  - **ALTER SYSTEM JOIN DATABASE**
- If it can not join in a cluster system again, then use DROP statement to exclude it.

- **ALTER DATABASE DROP INACTIVE CLUSTER MEMBERS**

In this case, the device corresponding to the cluster member which is excluded from a cluster system can be used again by using the following two methods.

- Method 1: Recreate the database of the local cluster member.
- Method 2: Reset the local cluster member by using `<alter database reset local cluster member statement>`.

The method 2 reduces the cost of recreating the tablespace comparing to the method 1.

## Examples

The following is an example of a reset by using `<alter database reset local cluster member statement>` after driving the local cluster member, which is excluded from the cluster system, up to LOCAL OPEN phase.

```
gSQL> \startup nomount
Startup success
gSQL> ALTER SYSTEM MOUNT DATABASE;
System altered.
gSQL> ALTER SYSTEM OPEN LOCAL DATABASE;
System altered.
gSQL> ALTER DATABASE RESET LOCAL CLUSTER MEMBER;
Database altered.
```

## Compatibility

The SQL standard does not define the concepts of the cluster.

## For More Information

Refer to the followings.

- **ALTER SYSTEM JOIN DATABASE**
- **ALTER DATABASE DROP INACTIVE CLUSTER MEMBERS**

## 18.22 ALTER DATABASE RESTORE

### Function

It restores the data files in the database or tablespace by using the incremental backup.

### Syntax

```

<alter database restore statement> ::=
    <database restore statement>
  | <tablespace restore statement>
  | <controlfile restore statement>
  ;
<database restore statement> ::=
    ALTER DATABASE RESTORE [ <until clause> ]
<until clause> ::=
    UNTIL CHANGE integer
<tablespace restore statement> ::=
    ALTER DATABASE RESTORE TABLESPACE tablespace_name
<controlfile restore statement> ::=
    ALTER DATABASE RESTORE CONTROLFILE FROM 'file_name'

```

### Invocation and Access Rules

ALTER DATABASE ON DATABASE privilege is required to perform <alter database restore statement>.

### Syntax Rules and Parameters

#### <database restore statement>

It restores the data files in the database by using the incremental backup.  
The database should be in MOUNT phase.



## <tablespace restore statement>

It restores the data files in the tablespace by using the incremental backup.

- The database should be in MOUNT or OPEN phase.
- The recovery in OPEN state can be performed only for the tablespaces in OFFLINE state. The recovery in MOUNT phase can be performed for the tablespace is either in ONLINE state or OFFLINE state.

## <controlfile restore statement>

The control file is recovered using 'file\_name'.

- The database should be in NOMOUNT phase.
- The absolute path is recommended for 'file\_name' but if relative path is described, then <GOLDILOC KS\_HOME>/wal/'file\_name' is used.

## Description

The data recovery using full backup uses OS copy command to directly copy the backup file to the data file path. The data recovery using incremental restores only the deleted data files or old data files.

## Examples

The following is an example of recovering the database by using the incremental backup.

```
ALTER DATABASE RESTORE;
```

The following is an example of recovering the tablespace by using the incremental backup.

```
ALTER DATABASE RESTORE TABLESPACE test_tbs;
```

The following is an example of recovering the database by using only the incremental backup whose LSN is smaller than 11123.

```
ALTER DATABASE RESTORE UNTIL CHANGE 11123;
```

The following is an example of recovering the control file by using controlfile.bak.

`ALTER DATABASE RESTORE CONTROLFILE FROM 'controlfile.bak'`

## Compatibility

The SQL standard does not define ALTER DATABASE statement.

## For More Information

Refer to the followings.

- ALTER DATABASE BACKUP
- ALTER TABLESPACE name BACKUP
- ALTER DATABASE RECOVER

## 18.23 ALTER INDEX

### Function

It alters the index definition.

### Syntax

```
<alter index statement> ::=  
    <alter index physical attribute statement>  
    | <rename index statement>  
    | <aging index statement>  
    | <rebuild statement>  
    ;
```

### Invocation and Access Rules

One of the following privilege is required to perform <alter index statement>.

- The owner of that index
- The owner of the table to which the index belongs
- CONTROL TABLE ON TABLE for the table to which the index belongs.
- (ALTER INDEX or CONTROL SCHEMA) ON SCHEMA for the schema to which the index belongs
- ALTER ANY INDEX ON DATABASE

### Syntax Rules and Parameters

#### <alter index physical attribute statement>

It alters physical attributes of the index.

For more information, refer to **ALTER INDEX name STORAGE**.

## ⟨rename index statement⟩

It alters the index name.

For more information, refer to **ALTER INDEX name RENAME TO**.

## ⟨aging statement⟩

It deletes the empty page of the index.

For more information, refer to **ALTER INDEX name AGING**.

## ⟨rebuild statement⟩

It rebuilds the index.

For more information, refer to **ALTER INDEX name REBUILD**.

## Description

Refer to the descriptions of each detailed statement.

## Examples

Refer to the examples of each detailed statement.

## Compatibility

The SQL standard does not define the concepts of the index.

## 18.24 ALTER INDEX name AGING

### Function

It deletes an empty page of the index.

### Syntax

```
<aging index statement> ::=  
    ALTER INDEX index_name AGING  
    ;
```

### Invocation and Access Rules

One of the following privilege is required to perform <aging index statement>.

- The owner of that index
- The owner of the table to which the index belongs
- CONTROL TABLE ON TABLE for the table to which the index belongs.
- (ALTER INDEX or CONTROL SCHEMA) ON SCHEMA for the schema to which the index belongs
- ALTER ANY INDEX ON DATABASE

### Syntax Rules and Parameters

#### index\_name

It is the name of the target index.

### Description

This syntax returns pages whose all keys are deleted among index pages to a segment. Aging is processed in two steps which are logical deletion and physical deletion. A logical deletion is disconnection of inde

x page, and it is performed when SCN of when deleting the last key of a page is smaller than the agable S CN of the system. Then the physical deletion is performed when the SCN of the logical deletion is smaller than the agable SCN of the system.



If the agable SCN of the system does not increase, then the empty page may not be deleted even though the index AGING statement succeeded.

## Examples

The following is an example of aging the index.

```
gSQL> select index_name, empty_blocks from user_indexes where index_name = 'T1X';
INDEX_NAME EMPTY_BLOCKS
-----
T1X          2
1 row selected.
gSQL> alter index t1x aging;
Index altered.
gSQL> select index_name, empty_blocks from user_indexes where index_name = 'T1X';
INDEX_NAME EMPTY_BLOCKS
-----
T1X          0
1 row selected.
```

## Compatibility

The SQL standard does not define the concepts of the index.

## For More Information

Refer to the followings.

- CREATE INDEX
- ALTER INDEX
- DROP INDEX

## 18.25 ALTER INDEX name REBUILD

### Function

It rebuilds an index.

### Syntax

```

<rebuild index statement> ::=
    ALTER INDEX index_name REBUILD
        [ ONLINE | OFFLINE ]
        [ <index attributes> [...] ]
        [ TABLESPACE tablespace_name ]
    ;
<index attributes> ::=
    <physical attribute clause>
    | STORAGE ( <segment attr clause> [...] )
    | <parallel clause>
<physical attribute clause> ::=
    PCTFREE integer
    | INITTRANS integer
    | MAXTRANS integer
<segment attr clause> ::=
    INITIAL <size_clause>
    | NEXT <size_clause>
    | MINSIZE <size_clause>
    | MAXSIZE <size_clause>
<size clause> ::=
    integer [ K | M | G | T ]
<parallel clause> ::=
    NOPARALLEL
    | PARALLEL [ integer ]

```

## Invocation and Access Rules

The user should satisfy the following conditions to perform `<rebuild index statement>`.

- The owner of that index
- The owner of the table to which the index belongs
- CONTROL TABLE ON TABLE for the table to which the index belongs.
- (ALTER INDEX or CONTROL SCHEMA) ON SCHEMA for the schema to which the index belongs
- ALTER ANY INDEX ON DATABASE

At least one of the following privileges for a tablespace in which the index is to be created is required.

- CREATE OBJECT ON TABLESPACE for that tablespace
- USAGE TABLESPACE ON DATABASE

## Syntax Rules and Parameters

### `index_name`

It is the name of the target index.

The schema name can be specified, and the user's default schema name is used when it is omitted.

### [ ONLINE | OFFLINE ]

It determines whether to allow DML on the table when rebuilding the index.

- ONLINE
  - It allows INSERT, UPDATE, and DELETE.
- OFFLINE
  - It does not allow INSERT, UPDATE, DELETE.
- When it is omitted, the default value is ONLINE.

### `<physical attribute clause>`

It defines the physical attribute information of an index.

- PCTFREE integer
  - Definition
    - It is the reserved space for adjusting the page split frequency caused by the key inserted in the page.



- It can use the value from 0 to 99.
- If it is omitted, the default value is the value set in the existing index.
- INITRANS integer
  - Definition
    - It specifies the initial number of transactions which can simultaneously access the page.
    - If the number of users who access the index is small, INITRANS is set to low, and if the number of users who simultaneously access the index is big, INITRANS is set to high.
    - If necessary, it is automatically increased to the specified MAXTRANS.
  - It can use the value from 1 to 32.
  - If it is omitted, the default value is the value set in the existing index.
- MAXTRANS integer
  - Definition
    - It specifies the maximum number of transactions which can simultaneously access the page.
  - It can use the value from 1 to 32.
  - If it is omitted, the default value is the value set in the existing index.

## <segment attr clause>

It specifies the information for the index storage space.

- INITIAL integer
  - Definition
    - It specifies the size of physical storage space which is initially allocated when creating the index.
    - This size is aligned to the EXTENT size of the TABLESPACE to which the table belongs. (e.g. If the EXT size is 8192 bytes, 'INITIAL 100' is actually operated as 8192 bytes. )
    - The size (aligned to the EXTENT size of TABLESPACE) should be equal to or bigger than MIN EXTENTS, or it should be equal to or less than MAXEXTENTS.
  - The minimum value is 1, and the maximum value depends on the system environment.
  - If it is omitted, the default value is the value set in the existing index.
- NEXT integer
  - Definition
    - It specifies the physical space size to be allocated when adding the space to the table.
    - This size is aligned to the EXTENT size of the TABLESPACE to which the table belongs. (e.g. If the EXT size is 8192 bytes, 'NEXT 100' is actually operated as 8192 bytes.)
    - NEXT operates as follows, depending on the remaining space size of the index available currently. (Obtained by subtracting the amount of currently used space from the MAXEXTENTS size)
  - If the remaining space size is 0, then it can not extend the space.
  - If the remaining space size is bigger than 0, but smaller than NEXT, then it allocates the

space as big as the remaining space.

- If the remaining space size is bigger than NEXT, then it allocates the space as big as the NEXT.

- The minimum value is 1 and the maximum value depends on the system environment.
  - If it is omitted, the default value is the value set in the existing index.
- MINSIZE integer
    - Definition
      - It is the minimum space size of the index.
      - The value should be equal to or smaller MAXSIZE.
    - This size is aligned to the EXTENT size of the TABLESPACE to which the index belongs.
    - The minimum value is 1 and the maximum value depends on the system environment.
    - If it is smaller than the size of two EXTENT, it is specified to the size of two EXTENT.
    - If it is omitted, the default value is the value set in the existing index.
  - MAXSIZE integer
    - Definition
      - It is the maximum space size of the index.
      - The value should be equal to or bigger than MINSIZE.
    - This size is aligned to the EXTENT size of the TABLESPACE to which the index belongs.
    - The minimum value is 1 and the maximum value depends on the system environment.
    - If it is omitted, the default value is the value set in the existing index.

## ⟨size clause⟩

It specifies the file size in bytes. (If the unit is omitted, the default value is bytes.)

- K: Kilobytes
- M: Megabytes
- G: Gigabytes
- T: Terabytes

## NOPARALLEL | PARALLEL [ integer ]

It specifies the number of threads to be used when rebuilding an index.

- NOPARALLEL
  - It does not rebuild an index in parallel.
- PARALLEL [integer]
  - It rebuilds an index in parallel.
  - If an integer is omitted or set as 0, then it follows INDEX\_BUILD\_PARALLEL\_FACTOR property.
  - The minimum value of an integer is 0 and the maximum value is 64.
  - If the integer or the property value is 0, then the system determines the optimal value.

- If it is omitted, the default value is NOPARALLEL.

## TABLESPACE tablespace\_name

It specifies the name of the tablespace in which the index is to be rebuilt.

- When it specifies tablespace\_name
  - if tablespace\_name is data tablespace, then it is rebuilt as a LOGGING index.
  - if tablespace\_name is temporary tablespace or nologging tablespace, then it is rebuilt as a NOLOGGING index.
- When TABLESPACE clause is omitted, then it is set to the tablespace of the existing index.

## Description

- Dropping the index fragmentation
  - The fragmentation may occur on the index page, when DML is frequently performed in the index. If the tree becomes too big comparing to the valid data, then the index volume becomes larger and the performance is degraded. In this case, rebuilding the index can solve the index fragmentation issue so that the index volume is reduced and the index performance is recovered.
- Altering the tablespace in the index
  - The tablespace in the previously created index can be altered.
  - However, LOGGING should be set properly according to whether the tablespace is TEMPORARY or not.
- Altering LOGGING setting in the index
  - The data tablespace should be set in TABLESPACE option to switch to the LOGGING index.
  - The temporary tablespace or the nologging tablespace should be set in TABLESPACE option to switch to the NOLOGGING index.

## Examples

The following is an example of altering the index logging setting and the tablespace.

```
gsq1> SELECT INDEX_NAME, TABLESPACE_NAME FROM INDEXES AS IDX, TABLESPACES AS TBS WHERE
IDX.TABLESPACE_ID = TBS.TABLESPACE_ID AND IDX.INDEX_NAME = 'T1X';
INDEX_NAME TABLESPACE_NAME
-----
T1X          MEM_TEMP_TBS
1 row selected.
gsq1> ALTER INDEX T1X REBUILD TABLESPACE MEM_DATA_TBS;
```

```
SELECT INDEX_NAME, TABLESPACE_NAME FROM INDEXES AS IDX, TABLESPACES AS TBS WHERE  
IDX.TABLESPACE_ID = TBS.TABLESPACE_ID AND IDX.INDEX_NAME = 'T1X';
```

```
INDEX_NAME TABLESPACE_NAME
```

```
-----
```

```
T1X          MEM_DATA_TBS
```

```
1 row selected.
```

## Compatibility

The SQL standard does not cover the concepts of the index.

## For More Information

Refer to the followings.

- [CREATE INDEX](#)
- [ALTER INDEX](#)
- [DROP INDEX](#)

## 18.26 ALTER INDEX name RENAME TO

### Function

It alters the index name.

### Syntax

```
<rename index statement> ::=  
    ALTER INDEX index_name  
        RENAME TO new_index_name  
    ;
```

### Invocation and Access Rules

One of the following privilege is required to perform <rename index statement>.

- The owner of that index
- The owner of the table to which the index belongs
- CONTROL TABLE ON TABLE for the table to which the index belongs
- (ALTER INDEX or CONTROL SCHEMA) ON SCHEMA for the schema to which the index belongs
- ALTER ANY INDEX ON DATABASE

### Syntax Rules and Parameters

#### index\_name

It is the name of the target index.

The schema name can not be described and it has the same schema name as same as that of the existing index.

## new\_index\_name

It is the name of the new index, and it should be a unique index name within the schema.

## Description

Refer to the syntax rules of each statement.

## Examples

The following is an example of altering the index name.

```
gSQL> ALTER INDEX t1_idx1 RENAME TO idx_t1_id;  
Index altered.
```

## Compatibility

The SQL standard does not define the concepts of the index.

## For More Information

Refer to the followings.

- CREATE INDEX
- ALTER INDEX
- DROP INDEX

## 18.27 ALTER INDEX name STORAGE

### Function

It alters the physical attributes of the index.

### Syntax

```

<alter index physical attribute statement> ::=
    ALTER INDEX index_name
    | <physical attribute clause>
    | [ STORAGE ( <segment attr clause> [...] ) ]
    ;
<physical attribute clause> ::=
    PCTFREE integer
    | INITTRANS integer
    | MAXTRANS integer
<segment attr clause> ::=
    INITIAL <size_clause>
    | NEXT <size_clause>
    | MINSIZE <size_clause>
    | MAXSIZE <size_clause>
<size clause> ::=
    integer [ K | M | G | T ]

```

### Invocation and Access Rules

One of the following privilege is required to perform <alter index physical attribute statement>.

- The owner of that index
- The owner of the table to which the index belongs
- CONTROL TABLE ON TABLE for the table to which the index belongs.
- (ALTER INDEX or CONTROL SCHEMA) ON SCHEMA for the schema to which the index belongs
- ALTER ANY INDEX ON DATABASE

## Syntax Rules and Parameters

### index\_name

It is the target index name.

### <physical attribute clause>

It defines the physical attribute information of the index.

- PCTFREE integer
  - Definition
    - The reserved space to adjust the frequency of page splits caused by inserting the key in the page.
    - It is applied only when the index bottom-up build.
  - It can use of the value from 0 to 99.
  - If it is omitted, the value set in DEFAULT\_INDEX\_PCTFREE property is used by default.
- INITRANS integer
  - Definition
    - The initial number of transactions simultaneously accessing the page.
    - If the number of users accessing the index is small, then INITRANS is set low. If the number of users simultaneously accessing the index is big, then INITRANS is set high.
    - If necessary, it is automatically increased to the specified MAXTRANS.
  - It can use the value from 1 to 32.
  - If it is omitted, the default value is 4.
- MAXTRANS integer
  - Definition
    - It specifies the maximum number of transaction simultaneously accessing the page.
  - It can use the value from 1 to 32.
  - If it is omitted, the default value is 8.

### <segment attr clause>

It specifies the information for the index storage space.

- INITIAL integer
  - Definition
    - It specifies the size of physical storage space which is initially allocated when creating the index.



- This size is aligned to the EXTENT size of the TABLESPACE to which the table belongs. (e.g. If the EXT size is 8192 bytes, 'INITIAL 100' is actually operated as 8192 bytes. )
    - The size (aligned to the EXTENT size of TABLESPACE) should be equal to or bigger than MIN EXTENTS, or it should be equal to or less than MAXEXTENTS.
    - It is applied only when the index bottom-up build.
  - The minimum value is 1, and the maximum value depends on the system environment.
  - If it is omitted, the default value is one EXTENT size of TABLESPACE to which the table belongs.
- NEXT integer
  - Definition
    - It specifies the physical space size to be allocated when adding the space to the table.
    - This size is aligned to the EXTENT size of the TABLESPACE to which the table belongs. (e.g. If the EXT size is 8192 bytes, 'NEXT 100' is actually operated as 8192 bytes.)
    - NEXT operates as follows depending on the remaining space size of the currently available in dex. (Obtained by subtracting the amount of currently used space from the MAXEXTENTS size)
  - If the remaining space size is 0, then it can not extend the space.
  - If the remaining space size is bigger than 0, but smaller than NEXT, then it allocates the space as big as the remaining space.
  - If the remaining space size is bigger than NEXT, then it allocates the space as big as the NEXT.
  - The minimum value is 1 and the maximum value depends on the system environment.
  - If it is omitted, the default value is one EXTENT size of TABLESPACE to which the index belongs.
- MINSIZE integer
  - Definition
    - It is the minimum space size of the index.
    - The value should be equal to or smaller MAXSIZE.
  - This size is aligned to the EXTENT size of the TABLESPACE to which the index belongs.
  - The minimum value is 1 and the maximum value depends on the system environment.
  - If it is smaller than the size of two EXTENT, it is specified to the size of two EXTENT.
  - If it is omitted, the default value is the size of two EXTENT.
- MAXSIZE integer
  - Definition
    - It is the maximum space size of the index.
    - The value should be equal to or bigger than MINSIZE.
  - This size is aligned to the EXTENT size of the TABLESPACE to which the index belongs.
  - The minimum value is 1 and the maximum value depends on the system environment.
  - If it is omitted, the default value is EXTENT size \* 2147483647(The maximum positive integer of INT32).

## <size clause>

It specifies the file size in byte. (If it is omitted, the default unit is bytes.)

- K: Kilobytes
- M: Megabytes
- G: Gigabytes
- T: Terabytes

## Description

Refer to the syntax rules of each statement.

## Examples

The following is an example of altering the physical attributes of the index.

```
gSQL> ALTER INDEX idx_t1_id PCTFREE 10 INITRANS 4 MAXTRANS 8;  
Index altered.
```

## Compatibility

The SQL standard does not define the concepts of the index.

## For More Information

Refer to the followings.

- CREATE INDEX
- ALTER INDEX
- DROP INDEX

## 18.28 ALTER PROFILE

### Function

It alters the password management method.

### Syntax

```

<alter profile statement> ::=
    ALTER PROFILE profile_name LIMIT
    { <password_parameters>, ... }
    ;

<password parameters> ::=
    FAILED_LOGIN_ATTEMPTS { integer | UNLIMITED | DEFAULT }
    | PASSWORD_LOCK_TIME { password_parameter_number_interval | UNLIMITED | DEFAULT }
    | PASSWORD_LIFE_TIME { password_parameter_number_interval | UNLIMITED | DEFAULT }
    | PASSWORD_GRACE_TIME { password_parameter_number_interval | UNLIMITED | DEFAULT }
    | PASSWORD_REUSE_MAX { integer | UNLIMITED | DEFAULT }
    | PASSWORD_REUSE_TIME { password_parameter_number_interval | UNLIMITED | DEFAULT }
    | PASSWORD_VERIFY_FUNCTION { <verify_policy> | NULL | DEFAULT }

<verify_policy> ::=
    KISA_VERIFY_FUNCTION
    | ORA12C_VERIFY_FUNCTION
    | ORA12C_STRONG_VERIFY_FUNCTION
    | VERIFY_FUNCTION_11G
    | VERIFY_FUNCTION

<password_parameter_number_interval> ::=
    integer
    | integer / integer

```

### Invocation and Access Rules

ALTER PROFILE ON DATABASE privilege is required to perform <alter profile statement>.

## Syntax Rules and Parameters

### **profile\_name**

It is a profile name to be altered.

### **FAILED\_LOGIN\_ATTEMPTS**

It sets the number of consecutive login attempts allowed to fail.

For more information, refer to **CREATE PROFILE**.

### **PASSWORD\_LOCK\_TIME**

It sets an account lockout duration (day) after the consecutive login failures.

For more information, refer to **CREATE PROFILE**.

### **PASSWORD\_LIFE\_TIME**

It sets the password lifetime (day).

For more information, refer to **CREATE PROFILE**.

### **PASSWORD\_GRACE\_TIME**

It sets a password expiration grace period when log in after **PASSWORD\_LIFE\_TIME**.

For more information, refer to **CREATE PROFILE**.

### **PASSWORD\_REUSE\_MAX**

It specifies the number of the recent passwords which can not be reused when a user wants to reuse the old password.

For more information, refer to **CREATE PROFILE**.

### **PASSWORD\_REUSE\_TIME**

It specifies the duration which the password can not be reused when a user wants to reuse the old password.

For more information, refer to **CREATE PROFILE**.

## PASSWORD\_VERIFY\_FUNCTION

It set the password complexity verification method.  
For more information, refer to [CREATE PROFILE](#).

### Examples

The following is an example of changing the profile to control the account lockout.

```
gSQL> ALTER PROFILE prof1 LIMIT
        FAILED_LOGIN_ATTEMPTS 3
        PASSWORD_LOCK_TIME 3;
Profile altered.
gSQL> COMMIT;
Commit complete.
```

The following is an example of changing the profile to control the password lifetime.

```
gSQL> ALTER PROFILE prof1 LIMIT
        PASSWORD_LIFE_TIME 90
        PASSWORD_GRACE_TIME 7;
Profile altered.
gSQL> COMMIT;
Commit complete.
```

The following is an example of changing the profile to control the password reusability.

```
gSQL> ALTER PROFILE prof1 LIMIT
        PASSWORD_REUSE_MAX DEFAULT
        PASSWORD_REUSE_TIME DEFAULT;
Profile altered.
gSQL> COMMIT;
Commit complete.
```

The following is an example of changing the profile to control the password complexity verification.

```
gSQL> ALTER PROFILE prof1 LIMIT
        PASSWORD_VERIFY_FUNCTION KISA_VERIFY_FUNCTION;
Profile altered.
gSQL> COMMIT;
```

Commit complete.

## Compatibility

The SQL standard does not define the concepts of the profile.

## For More Information

Refer to `DROP PROFILE`.

## 18.29 ALTER SEQUENCE

### Function

It alters the sequence.

### Syntax

```

<alter sequence generator statement> ::=
    ALTER SEQUENCE sequence_name <alter sequence generator options>
    ;
<alter sequence generator options> ::=
    <alter sequence generator option> [, ...]
<alter sequence generator option> ::=
    <alter sequence generator restart option>
    | <basic sequence generator option>
<alter sequence generator restart option> ::=
    RESTART [ WITH integer ]
<basic sequence generator option> ::=
    <sequence generator increment by option>
    | <sequence generator maxvalue option>
    | <sequence generator minvalue option>
    | <sequence generator cycle option>
    | <sequence generator cache option>
<sequence generator increment by option> ::=
    INCREMENT BY integer
<sequence generator maxvalue option> ::=
    MAXVALUE integer
    | (NO MAXVALUE | NOMAXVALUE)
<sequence generator minvalue option> ::=
    MINVALUE integer
    | (NO MINVALUE | NOMINVALUE)
<sequence generator cycle option> ::=
    CYCLE
    | (NO CYCLE | NOCYCLE)
<sequence generator cache option> ::=
    CACHE integer
  
```

## Invocation and Access Rules

One of the following privilege is required to perform `<alter sequence generator statement>`.

- The owner of that sequence
- (ALTER SEQUENCE or CONTROL SCHEMA) ON SCHEMA for the schema to which the sequence belongs
- ALTER ANY SEQUENCE ON DATABASE

## Syntax Rules and Parameters

### `sequence_name`

It is the sequence name to be altered.

It can define schema to which the sequence belongs such as `schema_name.sequence_name` and if `schema_name` is omitted, the default schema name of the user performing the statement is used.

### `<alter sequence generator restart option>`

It sets NEXT VALUE of the sequence.

However, it does not change the value of START WITH which is defined in `CREATE SEQUENCE` statement.

- RESTART
  - If the value is not specified, the value of START WITH defined in `<sequence generator definition>` is set as the next value of the sequence.
- RESTART WITH integer
  - It sets an integer value as the next value of the sequence.
  - The integer value should be between MINVALUE and MAXVALUE.

If `<alter sequence generator restart option>` clause is not specified, it changes the sequence attributes based on the current sequence value.

### `<sequence generator increment by option>`



It changes the interval of the sequence number.

The constraints and characteristics are as follows.

- A positive or negative value can be used, but 0 can not be used.
- The absolute value of the interval should be smaller than the difference between MINVALUE and MAXVALUE.
- If it is a positive value, it is an ascending sequence. If it is a negative value, it is a descending sequence.

## ⟨sequence generator maxvalue option⟩

It changes the maximum value which the sequence can generate.

However, the MAXVALUE should not be smaller than the current sequence value.

- MAXVALUE integer
  - The maximum value is in the range between the minimum (-9,223,372,036,854,775,808) and the maximum (+9,223,372,036,854,775,807) of 64 bit integer.
  - It should be equal to or bigger than the value of START WITH, and bigger than the value of MINVALUE.
- NO MAXVALUE | NOMAXVALUE
  - It changes the maximum value as follows.
    - If it is an ascending sequence, it is the maximum value (+9,223,372,036,854,775,807) of the 64 bit integer.
    - If it is a descending sequence, the value is -1.
    - NO MAXVALUE (SQL standard) and NOMAXVALUE are the reserved words with the same meaning, and either of them can be used.

## ⟨sequence generator minvalue option⟩

It changes the minimum value which the sequence can generate.

However, the MINVALUE should not be bigger than the current sequence value.

- MINVALUE integer
  - The minimum value is in the range between the minimum (-9,223,372,036,854,775,808) and the maximum (+9,223,372,036,854,775,807) of 64bit integer.
  - It should be equal to or smaller than the value of START WITH, and smaller than the value of MAXVALUE.
- NO MINVALUE | NOMINVALUE
  - It changes the minimum value as follows.
    - If it is an ascending sequence, the value is 1.
    - If it is a descending sequence, it is the minimum value (-9,223,372,036,854,775,808) of the 64bit integer.
  - NO MINVALUE (SQL standard) and NOMINVALUE are the reserved words with the same meaning.

g, and either of them can be used.

## ⟨sequence generator cycle option⟩

It changes whether to continue generating a value when the sequence value becomes the maximum or minimum value.

- **CYCLE**
  - If an ascending sequence becomes the maximum value, it generates the value again from the minimum value.
  - If a descending sequence becomes the minimum value, it generates the value again from the maximum value.
- **NO CYCLE | NOCYCLE**
  - It can not generate the value sequence when it becomes the maximum value or the minimum value.
  - **NO CYCLE** (SQL standard) and **NOCYCLE** are the reserved words with the same meaning, and either of them can be used.

## ⟨sequence generator cache option⟩

For quick access of a sequence, it defines the number of sequence values to be pre-loaded on the memory.

When restarting the database, the sequence value loaded on the memory is lost, and it starts from the value after loading.

- **CACHE integer**
  - The **CACHE** value should be equal to or bigger than 2.
  - If **CYCLE** exists, the **CACHE** value should not be bigger than the length of **CYCLE**.
    - The length of **CYCLE**:  $\text{CEIL}(\text{MAXVALUE} - \text{MINVALUE}) / \text{ABS}(\text{INCREMENT})$
- **NO CACHE | NOCACHE**
  - It does not pre-load the sequence value in memory.

## Description

It can not change **START WITH** which is one of the sequence attributes defined in **CREATE SEQUENCE** statement. To change **START WITH** attribute, it should be re-created by performing **CREATE SEQUENCE** statement after performing **DROP SEQUENCE** statement.

## Examples

The following is an example of restating the sequence value by using RESTART option, then assigning a new ID.

```
gSQL> SELECT id, name FROM t1 ORDER BY 1;
ID NAME
----
10 leekmo
42 mkkim
51 jhkim
172 ehpark
4 rows selected.
gSQL> ALTER SEQUENCE seq1 RESTART;
Sequence altered.
gSQL> UPDATE t1 SET id = seq1.NEXTVAL;
4 rows updated.
gSQL> SELECT id, name FROM t1 ORDER BY 1;
ID NAME
--
1 leekmo
2 mkkim
3 jhkim
4 ehpark
4 rows selected.
```

## Compatibility

The SQL standard does not define CACHE/ NO CACHE statement.

**Table 18-2** SQL standard compatibility

Feature ID	Description	Compatibility
T176	Sequence generator support	O
T177	Sequence generator support: simple restart option	O

## For More Information

Refer to the followings.

- `CREATE SEQUENCE`
- `DROP SEQUENCE`

## 18.30 ALTER SESSION CLEANUP GLOBAL TEMPORARY SEGMENT POOL;

### Function

It returns all segments which were caught to be reused in a session to tablespaces.

### Syntax

```
<alter session cleanup global temporary segment pool statement> ::=  
    ALTER SESSION CLEANUP GLOBAL TEMPORARY SEGMENT POOL  
    ;
```

### Description

It cleans up only the segments of a segment cache in the performed session.

### Examples

The following is an example of cleaning up the segment cache of the session.

```
gSQL> ALTER SESSION CLEANUP GLOBAL TEMPORARY SEGMENT POOL;  
Session altered.
```

### Compatibility

The SQL standard does not define the concepts of the segment cache of a global temporary table and a global temporary index.

## For More Information

Refer to [Global Temporary Table](#).

## 18.31 ALTER SESSION SET property\_name

### Function

It sets the property value of the session.

### Syntax

```
<alter session set statement> ::=  
    ALTER SESSION SET <property name> { = <property value> | TO DEFAULT }  
    ;
```

### Syntax Rules and Parameters

#### <property name>

It is the property name to be set.

For more information, refer to **Server Property** in an administration manual.

#### <property value>

It is the property value to be set.

#### TO DEFAULT

It sets the session property value as a system property value.

### Description

For more information about property, refer to **Server Property** in an administration manual.

## Examples

The following is an example of an error when setting ERROR HINT property so the hint clause includes an error.

```
gSQL> ALTER SESSION SET HINT_ERROR = ON;
Session altered.
gSQL> SELECT /*+ INDEX( t1, invalid_index ) */ name FROM t1 WHERE id = 1;
ERR-42000(16058): not applicable hint :
SELECT /*+ INDEX( t1, invalid_index ) */ name FROM t1 WHERE id = 1
      *
ERROR at line 1:
```

The following is an example of setting the session property value as the system property value.

```
gSQL> ALTER SESSION SET HINT_ERROR TO DEFAULT;
Session altered.
```

## Compatibility

The SQL standard does not define the concepts of the session property.

## For More Information

Refer to **ALTER SESSION SET property\_name**.



## 18.32 ALTER SYSTEM CHECKPOINT

### Function

It performs CHECKPOINT.

### Syntax

```
<alter system checkpoint statement> ::=  
    ALTER SYSTEM CHECKPOINT  
    [ AT <domain name> ]  
    ;
```

### Invocation and Access Rules

ALTER SYSTEM ON DATABASE privilege is required to perform <alter system checkpoint statement>.

### Syntax Rules and Parameters

#### <alter system checkpoint statement>

CHECKPOINT is an operation to ensure that all altered data by the committed transactions are written to disk.

- The database should be in OPEN phase.
- The database should be in TDS mode.
- When a full backup is in progress, the altered pages are not recorded in the data file, but only the REDO logs and control files are written to the disk. If the server is abnormally terminated in this situation, a media recovery should be performed.

#### <domain name>

It is a name of a member or a group for which the statement is performed.  
If it is omitted, it is performed for all groups.

## Description

The checkpoint operation records all changes by the committed transactions to disk, so it enables a rapid recovery at system error.

## Example

The following is an example of performing CHECKPOINT.

```
ALTER SYSTEM CHECKPOINT;
```

## Compatibility

The SQL standard does not define the concepts of CHECKPOINT.

## 18.33 ALTER SYSTEM CLEANUP BUFFER\_CACHE

### Function

It clears all buffer pages which can be free from the buffer cache.

### Syntax

```
<alter system cleanup buffer_cache statement> ::=  
    ALTER SYSTEM CLEANUP BUFFER_CACHE  
    [ AT <domain name> ]  
    ;
```

### Invocation and Access Rules

ALTER SYSTEM ON DATABASE privilege is required to perform <alter system cleanup buffer\_cache statement>.

### Syntax Rules and Parameters

#### <alter system cleanup buffer\_cache statement>

Syntax rules and parameters do not exist for <alter system cleanup buffer\_cache statement>.

#### <domain name>

It is a name of a member or a group for which the statement is performed.  
If it is omitted, it is performed for all groups.

## Description

It flushes and frees all free buffer pages cached in the buffer.



It should be used to clear the buffer cache before the performance measuring.  
If it is used on the operating server, then it could have fatal effect for the performance.

## Example

The following is an example of performing CLEANUP BUFFER\_CACHE.

```
ALTER SYSTEM CLEANUP BUFFER_CACHE;
```

## Compatibility

The SQL standard does not define the concepts of CLEANUP BUFFER\_CACHE.

## 18.34 ALTER SYSTEM CLEANUP PLAN

### Function

It cleans up all SQL plans.

### Syntax

```
<alter system cleanup plan statement> ::=  
    ALTER SYSTEM CLEANUP PLAN  
    [ AT <domain name> ]  
    ;
```

### Invocation and Access Rules

ALTER SYSTEM ON DATABASE privilege is required to perform <alter system cleanup plan statement>.

### Syntax Rules and Parameters

#### <alter system cleanup plan statement>

There is not any syntax rules or parameters for <alter system cleanup plan statement>.

#### <domain name>

It is a name of a member or a group for which the statement is performed.

If it is omitted, it is performed for all groups.

### Description

It cleans up all of the cached SQL plan. However, the plan whose V\$SQL CACHE.REF COUNT is bigger than 0 (the plan referenced by the prepared statement) is excluded from cleanup.

## Examples

The following is an example of executing CLEANUP PLAN.

```
ALTER SYSTEM CLEANUP PLAN;
```

## Compatibility

The SQL standard does not define the concepts of CLEANUP PLAN.

# 18.35 ALTER SYSTEM IRRECOVERABLE CLUSTER MEMBER

## Function

It specifies an irrecoverable cluster member.

## Syntax

```
<alter system irrecoverable cluster member statement> ::=  
    ALTER SYSTEM IRRECOVERABLE CLUSTER MEMBER <domain name>  
    ;
```

## Invocation and Access Rules

ALTER SYSTEM ON DATABASE privilege is required to perform <alter system irrecoverable cluster member statement>.

## Syntax Rules and Parameters

### <alter system irrecoverable cluster member statement>

There is not any syntax rules or parameters for <alter system irrecoverable cluster member statement>.

### <domain name>

It is a name of an irrecoverable member.

it is not allowed to specify all members in a group as an irrecoverable member.

## Description

It is used to restart the system excluding the corresponding member if the cluster failed to restart due to an irrecoverable member. The corresponding member should be dropped by using **ALTER DATABASE DROP INACTIVE CLUSTER MEMBERS** after the system succeeded to restart.

## Examples

The following is an example of executing **IRRECOVERABLE CLUSTER MEMBER**.

```
gSQL> ALTER SYSTEM IRRECOVERABLE CLUSTER MEMBER g1n1;
```

## Compatibility

The SQL standard does not define the concepts of **IRRECOVERABLE CLUSTER MEMBER**.



## 18.36 ALTER SYSTEM JOIN DATABASE

### Function

It includes a specific inactive cluster member in a cluster system again.

### Syntax

```
<alter system join database statement> ::=  
    ALTER SYSTEM JOIN DATABASE  
    ;
```

### Invocation and Access Rules

It can be performed in a cluster system.

ADMINISTRATION ON DATABASE privilege is required to perform <alter system join database statement>.

### Description

The inactive state of a cluster member means that it is not connected to the cluster system, and it occurs in the following cases.

- An error occurs on a cluster member in an operating cluster system.
- Trying to start-up the cluster system without driving the cluster member included in the cluster system.

If a specific cluster member is inactive, then the member can be included in a cluster system again according to the following procedure.

- Start-up the unstarted cluster member to the local open phase.

```
$ gsql sys gliese --as sysdba --dsn=G3N2  
gSQL> \startup
```

- Include it in a cluster system by using `<alter system join database statement>`.

```
$ gsql sys gliese --as sysdba --dsn=G3N2
gSQL> ALTER SYSTEM JOIN DATABASE;
```

Use `<alter system join database statement>` to make an inactive cluster member which is started up to the local open phase to participate in the cluster system without shutting it down.

To make the inactive cluster member to participate in the cluster system again, the database state of the cluster system and that of the inactive cluster member should be same.

The inactive cluster member can not participate in the cluster system again after the transaction altering the database in the cluster system completed.

To operate the cluster system normally the inactive cluster members should be dropped according to the following procedure when multiple inactive cluster members exist.

1. JOIN inactive cluster members which can participate in the cluster system.

```
gSQL> ALTER SYSTEM JOIN DATABASE;
```

2. DROP inactive cluster members which can not participate in the cluster system.

```
gSQL> ALTER DATABASE DROP INACTIVE CLUSTER MEMBERS;
```

All inactive cluster members which can participate in the cluster system should be included in the cluster system before dropping because all inactive cluster members are dropped from the cluster system when performing `<alter database drop inactive cluster member statement>`.

## Examples

```
gSQL> ALTER SYSTEM JOIN DATABASE;
```

## Compatibility

The SQL standard does not define the concepts of the cluster.

## For More Information

Refer to **ALTER DATABASE DROP INACTIVE CLUSTER MEMBERS**.

## 18.37 ALTER SYSTEM [KILL | DISCONNECT] SESSION

### Function

It terminates a session.

### Syntax

```
<alter system end session statement> ::=  
    ALTER SYSTEM DISCONNECT SESSION [<member_position>,<session_id>,<serial#> [<disconnect_option>] [AT <domain name>]  
    | ALTER SYSTEM KILL SESSION [<member_position>,<session_id>,<serial#> [AT <domain name>]  
    ;  
<disconnect_option> ::=  
    POST_TRANSACTION  
    | IMMEDIATE
```

### Invocation and Access Rules

ALTER SYSTEM ON DATABASE privilege is required to perform <alter system end session statement>.

### Syntax Rules and Parameters

#### <member\_position>

It is a member position of a session which is a disconnect/kill target in a cluster environment.

#### <session\_id>

It is the session ID.

## <serial#>

It is the SERIAL NUMBER of the session.

## <disconnect\_option>

- POST\_TRANSACTION: The session is terminated after completion of the transaction.
- IMMEDIATE: The session is immediately terminated without waiting for the completion of the transaction.

If <disconnect\_option> is not used, then it is operated in IMMEDIATE.

## <domain name>

It is a name of a member or a group for which the statement is performed.

If it is omitted, it is performed for all groups.

## Description

DISCONNECT SESSION can specify the options such as POST TRANSACTION and IMMEDIATE.

POST TRANSACTION terminates the session after the currently running transaction is completed. IMMEDIATE terminates the session after immediately cleaning up the currently running transaction.

KILL SESSION terminates the abnormal session which remains on the system without its process.

## Example

```
gSQL> SELECT USER_NAME, SESSION_ID, SERIAL_NO, SESSION_STATUS, PROGRAM_NAME FROM V$SESSION
WHERE USER_NAME = 'TEST';
```

USER_NAME	SESSION_ID	SERIAL_NO	SESSION_STATUS	PROGRAM_NAME
TEST	62	49	CONNECTED	gsq1
TEST	65	109	CONNECTED	gsq1net
TEST	66	130	CONNECTED	gsq1

3 rows selected.

```
gSQL> ALTER SYSTEM DISCONNECT SESSION 65, 109;
```

System altered.

## Compatibility

The SQL standard does not define it.

# 18.38 ALTER SYSTEM {MOUNT | OPEN} DATABASE

## E

### Function

It mounts the database on system, or alters the database to the state which is available for the service.

### Syntax

```

<alter system database statement> ::=
    ALTER SYSTEM <alter system database clause>
    ;
<alter system database clause> ::=
    MOUNT DATABASE
    | OPEN [ <database_scope> ] DATABASE [ <open_database_option> ]
<open_database_option> ::=
    READ WRITE [ NORESETLOGS | RESETLOGS ]
    | READ ONLY
<database_scope> ::=
    LOCAL
    | GLOBAL
  
```

### Invocation and Access Rules

ADMINISTRATION ON DATABASE privilege is required to perform <alter system database statement>.

### Syntax Rules and Parameters

#### <alter system database clause>

- MOUNT DATABASE
  - It mounts the database on the system.
- OPEN DATABASE

- It changes the database to the state which is available for the service.

## ⟨open database option⟩

- READ ONLY / READ WRITE
  - It specifies the read/write mode and drives the database.
  - If it is omitted, it is driven in READ WRITE.
- RESETLOGS / NORESETLOGS
  - It determines whether to keep the online redo logs after recovering the database.
  - NORESETLOGS maintains the existing redo log, but RESETLOGS initializes it.
  - RESETLOGS should be specified when the database is incompletely recovered.
  - If it is omitted, NORESETLOGS is specified by default.

## ⟨database\_scope⟩

- LOCAL
  - It starts up the LOCAL server to the OPEN phase.
- GLOBAL
  - It starts up the GLOBAL server, the entire server, to the OPEN phase.
- If it is omitted in a cluster environment, it starts up the GLOBAL server.

## Examples

The following is an example of driving the database in read only.

```
ALTER SYSTEM OPEN DATABASE READ ONLY;
```

The following is an example of driving the database in read/write, and initializing the online redo logs.

```
ALTER SYSTEM OPEN DATABASE READ WRITE RESETLOGS;
```

## Compatibility

The SQL standard does not define the concepts of MOUNT or OPEN in the database.



## For More Information

Refer to ALTER DATABASE RECOVER.

## 18.39 ALTER SYSTEM RECONNECT GLOBAL CONNECTION

### Function

It determines whether to reconnect to the session which is connected in GLOBAL CONNECTION form.

### Syntax

```
<alter system reconnect global connection statement> ::=  
    ALTER SYSTEM RECONNECT GLOBAL CONNECTION  
    ;
```

### Invocation and Access Rules

ALTER SYSTEM ON DATABASE privilege is required to perform <alter system reconnect global connection statement>.

### Description

Whether the GLOBAL CONNECTION client reconnects is determined by comparing SCN of a system object acquired from a server at the first connection and SCN of current server system object. This statement leads the client to reconnect by increasing SCN of the system object.

The client does not necessarily reconnect immediately after this statement is performed. The client reconnects by comparing SCN when the client executes a command in a server, and it does not try to reconnect if connections to all members from a client are valid.

## Examples

The following is an example of executing the statement.

```
gSQL> ALTER SYSTEM RECONNECT GLOBAL CONNECTION;  
System altered.
```

## Compatibility

The SQL standard does not define the concepts of GLOBAL CONNECTION.

## 18.40 ALTER SYSTEM RESET property\_name

### Function

It removes a property value from the property file.

### Syntax

```
<alter system reset statement> ::=  
    ALTER SYSTEM { RESET | UNSET } <property name>  
        [ SCOPE = { FILE | SPFILE } ]  
        [ AT <domain name> ]  
    ;
```

### Invocation and Access Rules

ALTER SYSTEM ON DATABASE privilege is required to perform <alter system reset statement>.

### Syntax Rules and Parameters

#### { RESET | UNSET }

RESET and UNSET are the reserved words with the same meaning, so either of them can be used.

#### <property name>

It is the property name to be removed.

For more information, refer to **Server Property** in an administration manual.

#### [ SCOPE = { FILE | SPFILE } ]

It removes the property from a property file, so only SCOPE=FILE/SPFILE can be used.

- SCOPE = FILE

- FILE and SPFILE are the reserved words with the same meaning, so either of them can be used.
- A property is removed from FILE, and is not applied to the current state.
- When restarting the database, the changes are applied.

If SCOPE clause is not specified, the default value is SCOPE = FILE.

## <domain name>

It is a name of a member or a group for which the statement is performed.

If it is omitted, it is performed for all groups.

## Description

If a property is altered by using SCOPE=FILE/SPFILE, the updated property value is stored in the property file, and it is applied when restarting the database.

When executing RESET, the updated property value is removed from the property file and the default value is used when restarting the database.

## Examples

The following is an example of altering the property by using SCOPE=FILE.

```
gSQL> ALTER SYSTEM SET PROCESS_MAX_COUNT=128 SCOPE=FILE;  
System altered.
```

The following is an example of removing the property altered above.

```
gSQL> ALTER SYSTEM RESET PROCESS_MAX_COUNT SCOPE=FILE;  
System altered.  
gSQL> ALTER SYSTEM RESET PROCESS_MAX_COUNT SCOPE=SPFILE;  
System altered.  
gSQL> ALTER SYSTEM RESET PROCESS_MAX_COUNT;  
System altered.  
gSQL> ALTER SYSTEM UNSET PROCESS_MAX_COUNT;  
System altered.
```

## Compatibility

The SQL standard does not define the concepts of the system property.

## For More Information

Refer to `ALTER SYSTEM SET property_name`.

## 18.41 ALTER SYSTEM SET property\_name

### Function

It sets the system property value.

### Syntax

```
<alter system set statement> ::=  
    ALTER SYSTEM SET <property name> { = <property value> | TO DEFAULT }  
        [ DEFERRED ]  
        [ SCOPE = [ MEMORY | { FILE | SPFILE } | BOTH ] ]  
    [AT <domain name>]  
    ;
```

### Invocation and Access Rules

ALTER SYSTEM ON DATABASE privilege is required to perform <alter system set statement>.

### Syntax Rules and Parameters

#### <property name>

It is the property name to be set.

For more information, refer to **Server Property** in an administration manual.

#### <property value>

It is the property value to be set.

## TO DEFAULT

It sets the system property value as the initial value of system driving.

## [ DEFERRED ]

It defines the point of time to apply the altered property.

- DEFERRED
  - It does not effect the current SESSION, but it is applied to the newly generated SESSION.
  - It can be applied when ISSYS\_MODIFIABL property value is IMMEDIATE/DEFERRED. It should be explicitly specified.
  - It is not applicable when the ISSYS\_MODIFIABLE property value is FALSE.

If ISSYS\_MODIFIABLE property value is IMMEDIATE, and DEFERRED is not explicitly specified, then it is immediately applied to all sessions.

## [ SCOPE = [ MEMORY | { FILE | SPFILE } | BOTH ] ]

It specifies the range which is affected by the property changes of the system.

- SCOPE = MEMORY
  - The changes are applied only to the current state, and the value is lost when restarting the database.
- SCOPE = FILE
  - FILE and SPFILE are the reserved words with the same meaning, so either of them can be used.
  - The changes are stored in FILE, and not applied to the current state.
  - The changes are applied when restarting the database.
- SCOPE = BOTH
  - The changes are stored in FILE, and applied to the current state.

If SCOPE clause is omitted, the default value is SCOPE = MEMORY.

If ISSYS\_MODIFIABLE property value is FALSE, it should be specified as SCOPE=FILE/SPFILE.

## <domain name>

It is a name of a member or a group for which the statement is performed.

If it is omitted, it is performed for all groups.



## Description

For more information, refer to **Server Property** in an administration manual.

## Examples

The following is an example of changing the property whose ISSYS\_MODIFIABLE property is DEFERRED.

```
gSQL> ALTER SYSTEM SET SPIN_COUNT=1000;  
ERR-22000(13019): Specified property cannot be modified.(SPIN_COUNT)  
gSQL> ALTER SYSTEM SET SPIN_COUNT=1000 DEFERRED;  
System altered.
```

The following is an example of changing the property whose ISSYS\_MODIFIABLE property is FALSE.

```
gSQL> ALTER SYSTEM SET PROCESS_MAX_COUNT=128;  
ERR-22000(13018): Specified property cannot be modified with this SCOPE  
option.(PROCESS_MAX_COUNT)  
gSQL> ALTER SYSTEM SET PROCESS_MAX_COUNT=128 SCOPE=FILE;  
System altered.
```

The following is an example of changing the altered property to the default value of when the session was connected.

```
gSQL> ALTER SYSTEM SET TRANSACTION_COMMIT_WRITE_MODE=0;  
System altered.  
gSQL> ALTER SYSTEM SET TRANSACTION_COMMIT_WRITE_MODE TO DEFAULT;  
System altered.  
gSQL> ALTER SYSTEM SET TRANSACTION_COMMIT_WRITE_MODE TO DEFAULT DEFERRED;  
System altered.
```

## Compatibility

The SQL standard does not define the concepts of the system property.

## For More Information

Refer to `ALTER SYSTEM RESET property_name`.

## 18.42 ALTER SYSTEM SWITCH LOGFILE

### Function

It alters the log files in CURRENT state to ACTIVE state in database.

### Syntax

```
<alter system switch logfile statement> ::=  
    ALTER SYSTEM SWITCH LOGFILE  
    [ AT <domain name> ]  
    ;
```

### Invocation and Access Rules

ALTER SYSTEM ON DATABASE privilege is required to perform <alter system switch logfile statement>.

### Syntax Rules and Parameters

#### <alter system switch logfile statement>

The database should be in MOUNT or OPEN phase.

#### <domain name>

It is a name of a member or a group for which the statement is performed.  
If it is omitted, it is performed for all groups.

## Description

Basically, if the log file in CURRENT state is filled, the log switch automatically occurs. That statement is used to forcibly execute log switch in special circumstances.

## Example

```
ALTER SYSTEM SWITCH LOGFILE;
```

## Compatibility

The SQL standard does not define the concepts of the LOGFILE.

## For More Information

Refer to `ALTER SYSTEM {MOUNT | OPEN} DATABASE.`

## 18.43 ALTER TABLE

### Function

It alters the table definition.

### Syntax

```

<alter table statement> ::=
    <alter table physical attribute statement>
  | <rename table statement>
  | <add column definition>
  | <drop column definition>
  | <alter column definition>
  | <rename column statement>
  | <add table constraint definition>
  | <drop table constraint definition>
  | <alter table constraint definition>
  | <rename table constraint statement>
  | <add table supplemental log statement>
  | <drop table supplemental log statement>
  | <rebalance statement>
  | <move shard statement>
  | <merge shards statement>
  | <split shard statement>
  | <rename shard statement>
  | <read { only | write } statement>
  ;

```

### Invocation and Access Rules

One of the following privilege is required to perform <alter table statement>.

- (ALTER or CONTROL TABLE) ON TABLE for the table
- (ALTER TABLE or CONTROL SCHEMA) ON SCHEMA for the schema to which the table belongs

- ALTER ANY TABLE ON DATABASE

## Syntax Rules and Parameters

### ⟨alter table physical attribute statement⟩

It alters physical attributes of a table.

For more information, refer to **ALTER TABLE name STORAGE**.

### ⟨rename table statement⟩

It renames the table.

For more information, refer to **ALTER TABLE name RENAME TO**.

### ⟨add column definition⟩

It adds columns to the table.

For more information, refer to **ALTER TABLE name ADD COLUMN**.

### ⟨drop column definition⟩

It drops a column from the table.

For more information, refer to **ALTER TABLE name SET UNUSED COLUMN**.

### ⟨alter column definition⟩

It alters the column definition in the table.

For more information, refer to **ALTER TABLE name ALTER COLUMN**.

### ⟨rename column statement⟩

It renames the column in the table.

For more information, refer to **ALTER TABLE name RENAME COLUMN**.

## ⟨add table constraint definition⟩

It adds constraints to the table.

For more information, refer to **ALTER TABLE name ADD CONSTRAINT**.

## ⟨drop table constraint definition⟩

It drops the constraints of the table.

For more information, refer to **ALTER TABLE name DROP CONSTRAINT**.

## ⟨alter table constraint definition⟩

It alters the constraints of the table.

For more information, refer to **ALTER TABLE name ALTER CONSTRAINT**.

## ⟨rename table constraint statement⟩

It renames the constraints of the table.

For more information, refer to **ALTER TABLE name RENAME CONSTRAINT**.

## ⟨add table supplemental log statement⟩

It sets to add information to the redo log when the data is altered in the table.

For more information, refer to **ALTER TABLE name ADD SUPPLEMENTAL LOG**.

## ⟨drop table supplemental log statement⟩

It sets not to add information to the redo log when the data is altered in the table.

For more information, refer to **ALTER TABLE name DROP SUPPLEMENTAL LOG**.

## ⟨rebalance statement⟩

It restores the data file matching by rebalancing the shard of the table or by synchronizing the broken shard in a cluster environment.

For more information, refer to **ALTER TABLE name REBALANCE**.

## ⟨move shard statement⟩

It rebalances a specific shard of a table on a specific cluster group in a cluster environment. For more information, refer to **ALTER TABLE name MOVE SHARD** .

## ⟨merge shards statement⟩

It merges specific shards in a table in a cluster environment, then rebalances them. For more information, refer to **ALTER TABLE name MERGE SHARDS**.

## ⟨split shard statement⟩

It rebalances a specific shard of a table on a specific cluster group by splitting the shard in a cluster environment. For more information, refer to **ALTER TABLE name SPLIT SHARD**.

## ⟨rename shard statement⟩

It renames a specific shard of a table in cluster environment. For more information, refer to **ALTER TABLE name RENAME SHARD**.

## ⟨read { only | write } statement⟩

It sets READ ( only | write ) to a table. For more information, refer to **ALTER TABLE name READ { ONLY | WRITE }**.

## Description

For more information, refer to the description of each detailed statement.

## Example

Refer to the examples of each detailed statement.



## Compatibility

The SQL standard does not define the following statements.

- `<alter table physical attribute statement>`
- `<rename table statement>`
- `<rename column statement>`
- `<rename table constraint statement>`
- `<add table supplemental log statement>`
- `<drop table supplemental log statement>`
- `<rebalance statement>`
- `<move shard statement>`
- `<split shard statement>`
- `<rename shard statement>`
- `<read { only | write } statement>`

## 18.44 ALTER TABLE name ADD COLUMN

### Function

It adds a column to the table.

### Syntax

```
<add column definition> ::=  
    ALTER TABLE table_name ADD [ COLUMN ] <column definition>  
    | ALTER TABLE table_name ADD [ COLUMN ] ( <column definition> [, ...] )  
    ;
```

### Invocation and Access Rules

The user should satisfy the following conditions to perform <add column definition>.

- At least one of the following privileges is required to alter the table.
  - (ALTER or CONTROL TABLE) ON TABLE for that table
  - (ALTER TABLE or CONTROL SCHEMA) ON SCHEMA for the schema to which the table belongs
  - ALTER ANY TABLE ON DATABASE
- If the constraints are specified with the added columns, the conditions should be satisfied to generate the constraints as follows.
  - One of the following privileges is required for the schema in which constraints are to be generated.
    - (ADD CONSTRAINT or CONTROL SCHEMA) ON SCHEMA for the schema
    - ALTER ANY TABLE ON DATABASE
  - If the key constraint is to be generated, one of the following privileges is required for the tablespace in which an index is to be created.
    - CREATE OBJECT ON TABLESPACE for the tablespace
    - USAGE TABLESPACE ON DATABASE
- The table owner has the following privileges for the added columns.
  - Privileges on all added columns
    - SELECT(columns) ON TABLE WITH GRANT OPTION

- INSERT(columns) ON TABLE WITH GRANT OPTION
- UPDATE(columns) ON TABLE WITH GRANT OPTION
- REFERENCES(columns) ON TABLE WITH GRANT OPTION
- Privilege on the constraint generated together
  - The owner of that constraint
  - The index owner generated together with the constraint

## Syntax Rules and Parameters

### table\_name

It is the table name to be altered.

It can define the schema to which the table belongs, such as schema\_name.table\_name. If schema\_name is omitted, the default schema name of the user performing the statement is used.

### ADD [ COLUMN ]

The reserved word COLUMN can be omitted.

### <column definition>

It defines the column to be added. For more information, refer to <column definition> clause of CREATE TABLE statement.

There should not be columns with the same name in a table.

If DEFAULT clause is specified when defining the column, the default value of all rows are stored in the added column.

If <identity column specification> clause is specified when defining the column, each automatically generated value of all rows is stored in the added column.

If NOT NULL constraint is specified when defining the column, the table should be empty or it should be specified together with DEFAULT or <identity column specification> clause.

### ( <column definition> [, ...] )

It adds multiple columns.

It lists multiple <column definition> inside the parentheses.

## Description

The added column is positioned at the end of the existing columns.

When specifying DEFAULT or <identity column specification> clause, the processing time is increased in proportion to the number of the rows in the table.

## Examples

The following is an example of adding a column.

```
gSQL> ALTER TABLE region ADD COLUMN r_new_comment VARCHAR(152);
Table altered.
```

The following is an example of adding multiple columns.

```
gSQL> ALTER TABLE partsupp ADD COLUMN (
  ps_retailprice NUMERIC(12,2),
  ps_acctbal NUMERIC(12,2), ps_mktsegment CHAR(10) );
Table altered.
```

The following is an example of adding the identity column and the column including DEFAULT clause.

```
gSQL> ALTER TABLE region ADD COLUMN (
  r_regionkey INTEGER GENERATED BY DEFAULT AS IDENTITY PRIMARY KEY,
  r_comment VARCHAR(152) DEFAULT 'N/A' );
```

Table altered.

```
gSQL> SELECT r_regionkey, r_name, r_comment FROM region;
```

R_REGIONKEY	R_NAME	R_COMMENT
1	AFRICA	N/A
2	AMERICA	N/A
3	ASIA	N/A
4	EUROPE	N/A
5	MIDDLE EAST	N/A

5 rows selected.

The following is an example of adding the column including the deferrable constraint.

```
gSQL> ALTER TABLE t1 ADD COLUMN ( id INTEGER CONSTRAINT t1_uk UNIQUE DEFERRABLE );  
Table altered.  
gSQL> COMMIT;  
Commit complete.
```

## Compatibility

The SQL standard does not define of adding multiple column definitions.

## For More Information

Refer to the followings.

- ALTER TABLE
- ALTER TABLE name SET UNUSED COLUMN
- ALTER TABLE name ALTER COLUMN
- ALTER TABLE name RENAME COLUMN

## 18.45 ALTER TABLE name ADD CONSTRAINT

### Function

It adds a table constraint.

### Syntax

```
<add table constraint definition> ::=  
    ALTER TABLE table_name  
        ADD <table constraint definition>  
    ;
```

### Invocation and Access Rules

The user should satisfy the following conditions to perform <add table constraint definition> clause.

- One of the following privileges is required on the table to create the constraint.
  - (ALTER or CONTROL TABLE) ON TABLE for that table
  - (ALTER TABLE or CONTROL SCHEMA) ON SCHEMA for the schema to which the table belongs
  - ALTER ANY TABLE ON DATABASE
- One of the following privileges is required on the schema to create the constraint.
  - (ADD CONSTRAINT or CONTROL SCHEMA) ON SCHEMA for the schema
  - ALTER ANY TABLE ON DATABASE
- One of the following privileges is required for the tablespace in which the index is to be created to create the key constraint
  - CREATE OBJECT ON TABLESPACE for the tablespace
  - USAGE TABLESPACE ON DATABASE
- The owner of the created constraint is determined as follow.
  - The owner of the schema to which the constraint belongs.
  - If the schema to which the constraint belongs is PUBLIC, then it is the user who executed the statement.



Constraints of PRIMARY KEY, UNIQUE in a cluster system should include all sharding keys.

## Syntax Rules and Parameters

### table\_name

It is the table name to be altered.

It can define the schema to which the table belongs, such as schema\_name.table\_name. If schema\_name is omitted, the default schema name of the user performing the statement is used.

### <table constraint definition>

It defines the constraint to be added.

NOT NULL constraint can not be added by using ALTER TABLE .. ADD CONSTRAINT statement, and it can be defined by using **ALTER TABLE name ALTER COLUMN** statement as follows.

```
ALTER TABLE t1 ALTER COLUMN c1 SET NOT NULL;
```

For more information, refer to <table constraint definition> clause of **CREATE TABLE** statement.

## Description

When adding the key constraints such as primary key, unique key, the index is automatically created for them.

## Examples

The following is an example of adding the primary key constraint to the table.

```
gSQL> ALTER TABLE t1 ADD PRIMARY KEY ( id );  
Table altered.
```

The following is an example of specifying the constraint name when adding a primary key constraint to the table.

```
gSQL> ALTER TABLE t1 ADD CONSTRAINT t1_pk PRIMARY KEY ( id );  
Table altered.
```

The following is an example of adding a DEFERRABLE constraint.

```
gSQL> ALTER TABLE t1 ADD CONSTRAINT t1_uk UNIQUE ( id ) DEFERRABLE INITIALLY DEFERRED;  
Table altered.  
gSQL> COMMIT;  
Commit complete.
```

## Compatibility

**Table 18-3** SQL standard compatibility

Feature ID	Description	Compatibility
F381	Extended schema manipulation	O

## For More Information

Refer to the followings.

- CREATE TABLE
- CREATE INDEX
- ALTER TABLE
- ALTER TABLE name DROP CONSTRAINT



## 18.46 ALTER TABLE name ADD GLOBAL SECONDARY INDEX

### Function

It creates a global secondary index in a table.

### Syntax

```

<alter table add global secondary index definition> ::=
    ALTER TABLE table_name
        ADD GLOBAL SECONDARY INDEX
            [ <index attributes> [...] ] [ TABLESPACE tablespace_name ]
    ;
<index attributes> ::=
    <physical attribute clause>
    | STORAGE ( <segment attr clause> [...] )
    | <parallel clause>
<physical attribute clause> ::=
    PCTFREE integer
    | INITTRANS integer
    | MAXTRANS integer
<segment attr clause> ::=
    INITIAL <size_clause>
    | NEXT <size_clause>
    | MINSIZE <size_clause>
    | MAXSIZE <size_clause>
<size clause> ::=
    integer [ K | M | G | T ]
<parallel clause> ::=
    NOPARALLEL
    | PARALLEL [ integer ]

```

## Invocation and Access Rules

<alter table add global secondary index definition> can be defined in a cluster system, and a user should satisfy the following conditions.

- At least one of the following privileges for a table in which the index is to be created is required.
  - (ALTER or CONTROL TABLE) ON TABLE for that table
  - (ALTER TABLE or CONTROL SCHEMA) ON SCHEMA for the schema to which the table belongs.
  - ALTER ANY TABLE ON DATABASE
- At least one of the following privileges for a tablespace in which the index is to be created is required.
  - CREATE OBJECT ON TABLESPACE for that tablespace
  - USAGE TABLESPACE ON DATABASE

## Syntax Rules and Parameters

### table\_name

It is the name of a table in which the index is to be created.

It can define a schema to which the table belongs such as schema\_name.table\_name.

If schema\_name is omitted, the default schema name of the user performing the statement is used.

### <physical attribute clause>

It defines the physical attribute information of the index.

- PCTFREE integer
  - Definition
    - The reserved space to adjust the frequency of page splits caused by inserting the key in the page.
    - It is applied only when the index bottom-up build.
  - It can use of the value from 0 to 99.
  - If it is omitted, the value set in DEFAULT\_INDEX\_PCTFREE property is used by default.
- INITRANS integer
  - Definition
    - The initial number of transactions simultaneously accessing the page.
    - If the number of users accessing the index is small, then INITRANS is set low. If the number of users simultaneously accessing the index is big, then INITRANS is set high.
    - If necessary, it is automatically increased to the specified MAXTRANS.

- It can use the value from 1 to 32.
- If it is omitted, the default value is 4.
- MAXTRANS integer
  - Definition
    - It specifies the maximum number of transaction simultaneously accessing the page.
  - It can use the value from 1 to 32.
  - If it is omitted, the default value is 8.

## ⟨segment attr clause⟩

It specifies the information for the index storage space.

- INITIAL integer
  - Definition
    - It specifies the size of physical storage space which is initially allocated when creating the index.
    - This size is aligned to the EXTENT size of the TABLESPACE to which the table belongs. (e.g. If the EXT size is 8192 bytes, 'INITIAL 100' is actually operated as 8192 bytes. )
    - The size (aligned to the EXTENT size of TABLESPACE) should be equal to or bigger than MIN EXTENTS, or it should be equal to or less than MAXEXTENTS.
  - The minimum value is 1, and the maximum value depends on the system environment.
  - If it is omitted, the default value is one EXTENT size of TABLESPACE to which the table belongs.
- NEXT integer
  - Definition
    - It specifies the physical space size to be allocated when adding the space to the index.
    - This size is aligned to the EXTENT size of the TABLESPACE to which the table belongs. (e.g. If the EXT size is 8192 bytes, 'NEXT 100' is actually operated as 8192 bytes.)
    - NEXT operates as follows, depending on the remaining space size of the index available currently. (Obtained by subtracting the amount of currently used space from the MAXEXTENTS size)
      - If the remaining space size is 0, then it can not extend the space.
      - If the remaining space size is bigger than 0, but smaller than NEXT, then it allocates the space as big as the remaining space.
      - If the remaining space size is bigger than NEXT, then it allocates the space as big as the NEXT.
  - The minimum value is 1 and the maximum value depends on the system environment.
  - If it is omitted, the default value is one EXTENT size of TABLESPACE to which the index belongs.
- MINSIZE integer
  - Definition
    - It is the minimum space size of the index.
    - The value should be equal to or smaller than MAXSIZE.

- This size is aligned to the EXTENT size of the TABLESPACE to which the index belongs.
- The minimum value is 1 and the maximum value depends on the system environment.
- If it is smaller than the size of two EXTENT, it is specified to the size of two EXTENT.
- If it is omitted, the default value is the size of two EXTENT.
- MAXSIZE integer
  - Definition
    - It is the maximum space size of the index.
    - The value should be equal to or bigger than MINSIZE.
  - This size is aligned to the EXTENT size of the TABLESPACE to which the index belongs.
  - The minimum value is 1 and the maximum value depends on the system environment.
  - If it is omitted, the default value is EXTENT size \* 2147483647(The maximum positive integer of INT32).

## ⟨size clause⟩

It specifies the file size in byte. (If it is omitted, the default unit is bytes.)

- K: Kilobytes
- M: Megabytes
- G: Gigabytes
- T: Terabytes

## NOPARALLEL | PARALLEL [ integer ]

It specifies the number of threads to be used when building an index.

- NOPARALLEL
  - It does not build an index in parallel.
- PARALLEL [integer]
  - It builds an index in parallel.
  - If an integer is omitted or set as 0, then it follows the property (INDEX\_BUILD\_PARALLEL\_FACTOR).
  - The minimum value of an integer is 0 and the maximum value is 16.
  - If the property value is 0, then the system determines the optimal value.
- If it is omitted, the default value is PARALLEL.

## TABLESPACE tablespace\_name

It specifies the name of the tablespace in which the index is to be stored.

- If it specifies tablespace\_name

- tablespace\_name should be a data tablespace to switch to the LOGGING index.
  - tablespace\_name should be a temporary tablespace or a nologging tablespace to switch to the NOLOGGING index
- If it omits TABLESPACE clause, then it follows the settings of the existing index.

## Description

A non-deterministic query requires the global secondary index. LOGGING index and NOLOGGING index have the following trade-offs.

- LOGGING index
  - Advantage: It does not separately build an index because the index is automatically restored by using the log when starting up the system.
  - Disadvantage: A disk I/O occurs because the changes on the index are recorded on the log when altering the row.
- NOLOGGING index
  - Advantage: A disk I/O does not occur for the changes on the index when altering the row.
  - Disadvantage: It automatically rebuilds the index when starting up the system because the log information of the index does not exist.

## Examples

The following is an example of adding a global secondary index to the table T1.

```
gSQL> ALTER TABLE T1 ADD GLOBAL SECONDARY INDEX;  
Table altered.  
gSQL> COMMIT;  
Commit complete.
```

The following is an example of creating a global secondary index as a logging index on the tablespace USER\_DATA\_TBS of table T1.

```
gSQL> ALTER TABLE T1 ADD GLOBAL SECONDARY INDEX LOGGING TABLESPACE USER_DATA_TBS;  
Table altered.  
gSQL> COMMIT;  
Commit complete.
```

The following is an example of creating a global secondary index as a nologging index on the tablespace

USER\_TEMP\_TBS of table T1.

```
gSQL> ALTER TABLE T1 ADD GLOBAL SECONDARY INDEX NOLOGGING TABLESPACE USER_TEMP_TBS;  
Table altered.  
gSQL> COMMIT;  
Commit complete.
```

## Compatibility

The SQL standard does not define the concepts of the global secondary index.

## For More Information

Refer to the followings.

- ALTER TABLE name DROP GLOBAL SECONDARY INDEX
- ALTER TABLE name ALTER GLOBAL SECONDARY INDEX
- CREATE TABLE

# 18.47 ALTER TABLE name ADD SUPPLEMENTAL LOG

## Function

If the primary key exists in the table when table data is altered, it sets to add the primary key value to redo log.

## Syntax

```
<add table supplemental log statement> ::=  
ALTER TABLE table_name  
    ADD SUPPLEMENTAL LOG DATA ( PRIMARY KEY ) COLUMNS  
;
```

## Invocation and Access Rules

One of the following privileges is required to perform <add table supplemental log statement>.

- (ALTER or CONTROL TABLE) ON TABLE for that table
- (ALTER TABLE or CONTROL SCHEMA) ON SCHEMA for the schema to which the table belongs
- ALTER ANY TABLE ON DATABASE

## Syntax Rules and Parameters

### table\_name

It is the table name to be altered.

It can define the schema to which the table belongs, such as schema\_name.table\_name. If schema\_name is omitted, the default schema name of the user performing the statement is used.

Even when the primary key does not exist in the table, the statement can be executed.

## Description

It additionally records SUPPLEMENTAL LOG when executing UPDATE/DELETE on the corresponding TABLE. The recorded SUPPLEMENTAL LOG is used to analyze logs or tools such as CDC.

To record SUPPLEMENTAL LOG of every TABLE, set the property as *SUPPLEMENTAL\_LOG\_DATA\_PRIMARY\_KEY = YES*.

## Example

The following is an example of setting to additionally add a primary key value to the redo log when changing the data in the table.

```
gSQL> ALTER TABLE t1 ADD SUPPLEMENTAL LOG DATA ( PRIMARY KEY ) COLUMNS;  
Table altered.
```

## Compatibility

The SQL standard does not cover <add table supplemental log statement>.

## For More Information

Refer to **ALTER TABLE name DROP SUPPLEMENTAL LOG**.



## 18.48 ALTER TABLE name ALTER COLUMN

### Function

It alters the column definition.

### Syntax

```

<alter column definition> ::=
    ALTER TABLE table_name
        ALTER [ COLUMN ] column_name <alter column action>
<alter column action> ::=
    <set column default clause>
  | <drop column default clause>
  | <set column not null clause>
  | <drop column not null clause>
  | <alter column data type clause>
  | <alter identity column specification>
  | <drop identity property clause>
  ;
<set column default clause> ::=
    SET DEFAULT <default option>
<drop column default clause> ::=
    DROP DEFAULT
<set column not null clause> ::=
    SET [ CONSTRAINT constraint_name ] NOT NULL [ <constraint characteristics> ]
<constraint characteristics> ::=
    [ NOT ] DEFERRABLE [ <constraint check time> ]
  | <constraint check time> [ [ NOT ] DEFERRABLE ]
<constraint check time> ::=
    INITIALLY DEFERRED
  | INITIALLY IMMEDIATE
<drop column not null clause> ::=
    DROP NOT NULL
<alter column data type clause> ::=
    SET DATA TYPE <data type>
<alter identity column specification> ::=

```

```

    <set identity column generation clause> [ <alter identity column option> ... ]
  | <alter identity column option> ...
<set identity column generation clause> ::=
  SET GENERATED { ALWAYS | BY DEFAULT }
<alter identity column option> ::=
  <alter sequence generator restart option>
  | [ SET ] <basic sequence generator option>
<alter sequence generator restart option> ::=
  RESTART [ WITH integer ]
<basic sequence generator option> ::=
  <sequence generator increment by option>
  | <sequence generator maxvalue option>
  | <sequence generator minvalue option>
  | <sequence generator cycle option>
  | <sequence generator cache option>
<drop identity property clause> ::=
  DROP IDENTITY

```

## Invocation and Access Rules

One of the following privileges is required to performing <alter column definition>.

- (ALTER or CONTROL TABLE) ON TABLE for that table
- (ALTER TABLE or CONTROL SCHEMA) ON SCHEMA for the schema to which the table belongs
- ALTER ANY TABLE ON DATABASE

## Syntax Rules and Parameters

### table\_name

It is the table name to be altered.

It can define the schema to which the table belongs, such as schema\_name.table\_name. If schema\_name is omitted, the default schema name of the user performing the statement is used.

## ALTER [ COLUMN ]

The reserved word COLUMN can be omitted.

### column\_name

It is the column name to be altered.

### ⟨set column default clause⟩

It sets the default value of the column.

It should not be an identity column.

The default value set when using the DEFAULT clause is used in INSERT statement later.

The data type of DEFAULT expression should be compatible with the data type of the column.

If the data type is not compatible or the expression is not valid, an error occurs.

For more information, refer to ⟨default clause⟩ of CREATE TABLE statement.

### ⟨drop column default clause⟩

It drops the default value of the column.

It should not be an identity column.

If the default value is dropped, NULL is set when using DEFAULT clause in INSERT statement.

### ⟨set column not null clause⟩

- SET [CONSTRAINT constraint\_name] NOT NULL [ ⟨constraint characteristics⟩ ]
  - It sets NOT NULL constraint on the column.
  - NULL is not allowed as the column value.
  - NULL should not exist in the column.
- If [CONSTRAINT constraint\_name] is omitted, the constraint name is automatically given.
- If ⟨constraint characteristics⟩ is omitted, it has NOT DEFERRABLE INITIALLY IMMEDIATE property.
- The Identity column can not have DEFERRABLE property.

For more information about the DEFERRABLE constraint, refer to SET CONSTRAINTS.

## <drop column not null clause>

- DROP NOT NULL
  - It drops NOT NULL constraint from the column.

## <alter column data type clause>

- SET DATA TYPE <data type>
  - It changes the data type of the column.



SET DATA TYPE is a DDL statement which is automatically committed.

The type conversion can be executed among the same family, and it should satisfy the following conditions.

**Table 18-4** Conversion of character string type

from $\mathbb{W}$ to	CHAR(n)	VARHCHAR(n)	LONG VARCHAR
CHAR(m)	X	X	X
VARCHAR(m)	X	$n \geq m$	X
LONG VARCHAR	X	X	O

The conversion of char length unit should satisfy the following condition.

**Table 18-5** Conversion of character length unit

from $\mathbb{W}$ to	OCTETS	CHARACTERS
OCTETS	O	O
CHARACTERS	X	O

**Table 18-6** Conversion of binary string type

from $\mathbb{W}$ to	BINARY(n)	VARBINARY(n)	LONG VARBINARY
BINARY(m)	X	X	X
VARBINARY(m)	X	$n \geq m$	X
LONG VARBINARY	X	X	O

**Table 18-7** Conversion of numeric type

from W to	SM ALLI NT	INTEGER	BIGINT	NU MER IC	NU MER IC(q )	NU MER IC(q, t)	NU MBE R(q)	NUMBER (q,t)	REA L	DOU BLE P RECIS ION	FLO AT	FLOAT (q)	NU MBE R
SMAL LINT	O	O	O	O	q >= 5	q >= 5 t >= 0 (q-t) >= 5	q >= 5	q >= 5 t >= 0 (q-t) >= 5	O	O	O	ddc(q) >= 5	O
INTE GER	X	O	O	O	q >= 10	q >= 10 t >= 0 (q-t) >= 10	q >= 10	q >= 10 t >= 0 (q-t) >= 10	X	O	O	ddc(q) >= 10	O
BIGIN T	X	X	O	O	q >= 19	q >= 19 t >= 0 (q-t) >= 19	q >= 19	q >= 19 t >= 0 (q-t) >= 19	X	X	O	ddc(q) >= 19	O
NUM ERIC	X	X	X	O	q == 38	q == 38 t == 0	q == 38	q == 38 t == 0	X	X	O	ddc(q) == 38	O
NUM ERIC (p)	5 >= p	10 >= p	19 >= p	O	q >= p	q >= p t >= 0 (q-t) >= p	q >= p	q >= p t >= 0 (q-t) >= p	8 >= p	16 >= p	O	ddc(q) >= p	O
NUM ERIC (p,s)	5 >= p 0 >= s 5 >= (p-s)	10 >= p 0 >= s 10 >= (p-s)	19 >= p 0 >= s 9 >= (p-s)	38 >= p 0 >= s 38 >= (p-s)	q >= p 0 >= s q >= (p-s)	q >= p t >= s (q-t) >= (p-s)	q >= p 0 >= s q >= (p-s)	q >= p t >= s (q-t) >= (p-s)	8 >= p	16 >= p	O	ddc(q) >= p	O
NUM	5 >=				q >=	q >=	q >=	q >= p	8 >=	16 >=		ddc(q)	

from W to	SMALLINT	INTEGER	BIGINT	NUMERIC	NUMERIC(q)	NUMERIC(q,t)	NUMBER(q)	NUMBER(q,t)	REAL	DOUBLE PRECISION	FLOAT	FLOAT(q)	NUMBER
BER(p)	p	10 >= p	19 >= p	0	p	0 (q-t) >= p	p	t >= 0 (q-t) >= p	p	p	0	>= p	0
NUMBER(p,s)	5 >= p 0 >= s 5 >= (p-s)	10 >= p 0 >= s 10 >= (p-s)	19 >= p 0 >= s 19 >= (p-s)	38 >= p 0 >= s 3 >= (p-s)	q >= p 0 >= s q >= (p-s)	q >= p t >= s (q-t) >= (p-s)	q >= p 0 >= s q >= (p-s)	q >= p t >= s (q-t) >= (p-s)	8 >= p	16 >= p	0	ddc(q) >= p	0
REAL	X	X	X	X	X	X	X	X	0	0	0	ddc(q) >= 8	0
DOUBLE PRECISION	X	X	X	X	X	X	X	X	X	0	0	ddc(q) >= 16	0
FLOAT	X	X	X	X	X	X	X	X	X	X	0	ddc(q) == 38	0
FLOAT(p)	X	X	X	X	X	X	X	X	8 >= ddc(p)	16 >= ddc(p)	0	ddc(q) >= ddc(p)	0
NUMBER	X	X	X	X	X	X	X	X	X	-	0	ddc(q) == 38	0

Decimal digit count (ddc) value for the FLOAT (p) is as follows.

**Table 18-8** Decimal digit count (ddc) value

FLOAT(p)	ddc(p)
1 ~ 3	1
4 ~ 6	2
7 ~ 9	3
10 ~ 13	4
14 ~ 16	5
17 ~ 19	6
20 ~ 23	7
24 ~ 26	8
27 ~ 29	9

FLOAT(p)	ddc(p)
30 ~ 33	10
34 ~ 36	11
37 ~ 39	12
40 ~ 43	13
44 ~ 46	14
47 ~ 49	15
50 ~ 53	16
54 ~ 56	17
57 ~ 59	18
60 ~ 63	19
64 ~ 66	20
67 ~ 69	21
70 ~ 73	22
74 ~ 76	23
77 ~ 79	24
80 ~ 83	25
84 ~ 86	26
87 ~ 89	27
90 ~ 93	28
94 ~ 96	29
97 ~ 99	30
100 ~ 103	31
104 ~ 106	32
107 ~ 109	33
110 ~ 113	34
114 ~ 116	35
117 ~ 119	36
120 ~ 123	37
124 ~ 126	38

All numeric types are managed in the same structure, and each numeric type is as same as the following NUMBER (p, s) expression.

**Table 18-9** NUMBER expressions of the numeric types

Numeric type	NUMBER(p,s) expression
SMALLINT	NUMBER(5,0)
INTEGER	NUMBER(10,0)
BIGINT	NUMBER(19,0)
NUMERIC	NUMBER(38,0)
NUMERIC(p)	NUMBER(p,0)

Numeric type	NUMBER(p,s) expression
NUMERIC(p,s)	NUMBER(p,s)
NUMBER(p)	NUMBER(p,0)
NUMBER(p,s)	NUMBER(p,s)
REAL	NUMBER(8,N/A) <= FLOAT(24)
DOUBLE PRECISION	NUMBER(16,N/A) <= FLOAT(53)
FLOAT	NUMBER(38,N/A) <= FLOAT(126)
FLOAT(p)	NUMBER( ddc(p), N/A )
NUMBER	NUMBER(38, N/A )

Native numeric type is as same with as C language numeric type, and it can not be converted to another type.

**Table 18-10** Conversion of native numeric type

from W to	NATIVE_SMALLINT	NATIVE_INTEGER	NATIVE_BIGINT	NATIVE_REAL	NATIVE_DOUBLE
NATIVE_SMALLINT	O	X	X	X	X
NATIVE_INTEGER	X	O	X	X	X
NATIVE_BIGINT	X	X	O	X	X
NATIVE_REAL	X	X	X	O	X
NATIVE_DOUBLE	X	X	X	X	O

**Table 18-11** Conversion of boolean type

from W to	BOOLEAN
BOOLEAN	O

**Table 18-12** Conversion of date/time type (TZ: WITH TIME ZONE)

from W to	DATE	TIME	TIME(g)	TIME TZ	TIME(g) TZ	TIMESTAMP	TIMESTAMP P(g)	TIMESTAMP P TZ	TIMESTAMP (g) TZ
DATE	O	X	X	X	X	X	X	X	X
TIME	X	O	g >= 6	X	X	X	X	X	X
TIME(f)	X	6 >= f	g >= f	X	X	X	X	X	X
TIME TZ	X	X	X	O	g >= 6	X	X	X	X
TIME(f) TZ	X	X	X	6 >= f	g >= f	X	X	X	X
TIMESTAMP	X	X	X	X	X	O	g >= 6	X	X
TIMESTAMP (f)	X	X	X	X	X	6 >= f	g >= f	X	X
TIMESTAMP	X	X	X	X	X	X	X	O	g >= 6



from $\mathbb{W}$ to	DATE	TIME	TIME(g)	TIME TZ	TIME(g) TZ	TIMESTAMP	TIMESTAMP(g)	TIMESTAMP TZ	TIMESTAMP(g) TZ
TZ									
TIMESTAMP(f) TZ	X	X	X	X	X	X	X	6 $\geq$ f	g $\geq$ f

Table 18-13 Type conversion of INTERVAL YEAR TO MONTH family (If p,q are omitted, then it is 2.)

from $\mathbb{W}$ to	YEAR(q)	MONTH(q)	YEAR(q) TO MONTH
YEAR(p)	q $\geq$ p	X	X
MONTH(p)	X	q $\geq$ p	X
YEAR(p) TO MONTH	X	X	q $\geq$ p

Table 18-14 Type conversion of INTERVAL DAY TO TIME family (If p,q are omitted, then it is 2.) (If f,g are omitted, then it is 6.)

from $\mathbb{W}$ to	DAY(q)	HOUR(q)	MINUTE(q)	SECOND(q, g)	DAY(q) TO HOUR	DAY(q) TO MINUTE	DAY(q) TO SECOND(g)	HOUR(q) TO MINUTE	HOUR(q) TO SECOND(g)	MINUTE(q) TO SECOND(g)
DAY(p)	q $\geq$ p	X	X	X	X	X	X	X	X	X
HOUR(p)	X	q $\geq$ p	X	X	X	X	X	X	X	X
MINUTE(p)	X	X	q $\geq$ p	X	X	X	X	X	X	X
SECOND(p, f)	X	X	X	q $\geq$ p g $\geq$ f	X	X	X	X	X	X
DAY(p) TO HOUR	X	X	X	X	q $\geq$ p	X	X	X	X	X
DAY(p) TO MINUTE	X	X	X	X	X	q $\geq$ p	X	X	X	X
DAY(p) TO SECOND(f)	X	X	X	X	X	X	q $\geq$ p g $\geq$ f	X	X	X
HOUR(p) TO MINUTE	X	X	X	X	X	X	X	q $\geq$ p	X	X
HOUR(p) TO SECOND(f)	X	X	X	X	X	X	X	X	q $\geq$ p g $\geq$ f	X
MINUTE(p)	X	X	X	X	X	X	X	X	X	q $\geq$ p

from W to	DAY (q)	HO UR (q)	MIN UTE (q)	SECO ND(q, g)	DAY(q) TO HOU R	DAY(q) T O MINUT E	DAY(q) T O SECON D(g)	HOUR(q) TO MINU TE	HOUR(q) T O SECOND (g)	MINUTE(q) TO SECOND (g)
TO SECOND (f)										g >= f

Table 18-15 Conversion of ROWID type

from W to	ROWID
ROWID	O

## <alter identity column specification>

It alters the identity property of the column.

The column should be an identity column.

- SET GENERATED [ ALWAYS | BY DEFAULT ]
  - It changes the method of generating the identity column.
  - For more information, refer to <identity column specification> of CREATE TABLE statement.
- <alter sequence generator restart option>
  - It changes NEXT VALUE of the identity column.
  - For more information, refer to <alter sequence generator restart option> clause of ALTER SEQUENCE statement.
- <basic sequence generator option>
  - It changes the property of the identity column.
  - In SQL standard, it is defined to be described in the form of SET <basic sequence generator option>, but it can be omitted.
  - For more information, refer to ALTER SEQUENCE statement.

## <drop identity property clause>

It drops the identity property of the column.

The column should be the identity column.

## Description

SET NOT NULL clause requires the time for checking null in proportion to the number of table rows.

The following columns do not allow NULL values. In other words, even if DROP NOT NULL clause is performed, NULL is not allowed in the following cases.

- A column which includes NOT NULL constraint
- A column which is included in primary key constraint
- An identity column

The change of the default value using SET DEFAULT clause and the change of the identity property using <alter identity column specification> clause, is applied to INSERT or UPDATE statement which is performed later.

## Examples

The following is an example of setting DEFAULT property to the column.

```
gSQL> ALTER TABLE region ALTER COLUMN r_comment SET DEFAULT 'N/A';  
Table altered.
```

The following is an example of dropping DEFAULT property from the column.

```
gSQL> ALTER TABLE region ALTER COLUMN r_comment DROP DEFAULT;  
Table altered.
```

The following is an example of setting NOT NULL constraint to the column.

```
gSQL> ALTER TABLE region ALTER COLUMN r_regionkey SET NOT NULL;  
Table altered.
```

The following is an example of dropping the NOT NULL constraint from the column.

```
gSQL> ALTER TABLE region ALTER COLUMN r_regionkey DROP NOT NULL;  
Table altered.
```

The following is an example of extending the data type size of the column.

```
gSQL> ALTER TABLE region ALTER COLUMN r_comment SET DATA TYPE VARCHAR(512);  
Table altered.
```

The following is an example of restarting the next value of the identity column.

```
gSQL> ALTER TABLE region ALTER COLUMN r_regionkey RESTART;
Table altered.
```

The following is an example of dropping the identity property from the column.

```
gSQL> ALTER TABLE region ALTER COLUMN r_regionkey DROP IDENTITY;
Table altered.
```

## Compatibility

**Table 18-16** The SQL standards compatibility

Feature ID	Description	Compatibility
F381	Extended schema manipulation	X
F382	Alter column data type	O
F383	Set column not null clause	O
F384	Drop identity property value	O
F385	Drop column generation expression clause	X
F386	Set identity column generation clause	O
S043	Enhanced reference types	X
T174	Identity columns	O
T178	Identity columns: simple restart option	O

## For More Information

Refer to the followings.

- **ALTER TABLE**
- **ALTER TABLE name ADD COLUMN**
- **ALTER TABLE name SET UNUSED COLUMN**
- **ALTER TABLE name RENAME COLUMN**

## 18.49 ALTER TABLE name ALTER CONSTRAINT

### Function

It alters the characteristics of the table constraint.

### Syntax

```

<alter table constraint definition> ::=
    ALTER TABLE table_name
        ALTER <constraint object> <constraint characteristics>
    ;
<constraint object> ::=
    CONSTRAINT constraint_name
    | PRIMARY KEY
    | UNIQUE ( column_name [, ...] )
<constraint characteristics> ::=
    [ NOT ] DEFERRABLE [ <constraint check time> ]
    | <constraint check time> [ [ NOT ] DEFERRABLE ]
<constraint check time> ::=
    INITIALLY DEFERRED
    | INITIALLY IMMEDIATE
  
```

### Invocation and Access Rules

One of the following privileges is required to perform <alter table constraint definition>.

- (ALTER or CONTROL TABLE) ON TABLE for that table
- (ALTER TABLE or CONTROL SCHEMA) ON SCHEMA for the schema to which the table belongs
- ALTER ANY TABLE ON DATABASE



Cluster does not support the deferrable constraints.

## Syntax Rules and Parameters

### table\_name

It is the table name to be altered.

It can define the schema to which the table belongs, such as schema\_name.table\_name. If schema\_name is omitted, the default schema name of the user performing the statement is used.

### <constraint object>

The constraint to be altered is specified as follows.

- CONSTRAINT constraint\_name
  - The constraint name to be altered.
- PRIMARY KEY
  - PRIMARY KEY constraint of the table
- UNIQUE( column [,...] )
  - UNIQUE constraint which satisfies the column list.

### DEFERRABLE | NOT DEFERRABLE

It alters whether the constraint state is deferrable.

- DEFERRABLE
  - The constraint is altered to be deferrable.
- NOT DEFERRABLE
  - The constraint is altered not to be deferrable.

For more information about the deferrable constraints, refer to **SET CONSTRAINTS**.

### INITIALLY IMMEDIATE | INITIALLY DEFERRED

It alters an initial value of the check point for the constraint.

- INITIALLY IMMEDIATE
  - It checks the constraints at the time of DML.
- INITIALLY DEFERRED
  - It checks the constraints at the time of COMMIT.

The constraints defined as NOT DEFERRABLE can not be altered to INITIALLY DEFERRED.

## Description

For more information about the deferrable constraints, refer to [SET CONSTRAINTS](#).

## Example

The following is an example that the constraint t1\_uk is set as deferrable and its checking time is set as DEFERRED.

```
gSQL> ALTER TABLE t1 ALTER CONSTRAINT t1_uk DEFERRABLE INITIALLY DEFERRED;
Table altered.
gSQL> COMMIT;
Commit complete.
```

## Compatibility

The SQL standard does not define the following clauses.

- ALTER PRIMARY KEY clause
- ALTER UNIQUE(column [...]) clause

**Table 18-17** SQL standard compatibility

Feature ID	Description	Compatibility
F492	Optional table constraint enforcement	X

## 18.50 ALTER TABLE name ALTER GLOBAL SECONDARY INDEX

### Function

It alters the physical attributes of the global secondary index in the table.

### Syntax

```

<alter table alter global secondary index storage statement> ::=
    ALTER TABLE table_name ALTER GLOBAL SECONDARY INDEX
        <physical attribute clause>
        | [ STORAGE ( <segment attr clause> [...] ) ]
    ;
<physical attribute clause> ::=
    PCTFREE integer
    | INITTRANS integer
    | MAXTRANS integer
<segment attr clause> ::=
    INITIAL <size_clause>
    | NEXT <size_clause>
    | MINSIZE <size_clause>
    | MAXSIZE <size_clause>
<size clause> ::=
    integer [ K | M | G | T ]

```

### Invocation and Access Rules

One of the following privileges is required to perform <alter table alter global secondary index storage statement>.

- (ALTER or CONTROL TABLE) ON TABLE for that table
- (ALTER TABLE or CONTROL SCHEMA) ON SCHEMA for the schema to which the table belongs
- ALTER ANY TABLE ON DATABASE



## Syntax Rules and Parameters

### table\_name

It is the name of a table in which the index is to be created.

It can define a schema to which the table belongs such as schema\_name.table\_name.

If schema\_name is omitted, the default schema name of the user performing the statement is used.

### <physical attribute clause>

It defines the physical attribute information of the index.

- PCTFREE integer
  - Definition
    - The reserved space to adjust the frequency of page splits caused by inserting the key in the page.
    - It is applied only when the index bottom-up build.
  - It can use of the value from 0 to 99.
  - If it is omitted, the value set in DEFAULT\_INDEX\_PCTFREE property is used by default.
- INITRANS integer
  - Definition
    - The initial number of transactions simultaneously accessing the page.
    - If the number of users accessing the index is small, then INITRANS is set low. If the number of users simultaneously accessing the index is big, then INITRANS is set high.
    - If necessary, it is automatically increased to the specified MAXTRANS.
  - It can use the value from 1 to 32.
  - If it is omitted, the default value is 4.
- MAXTRANS integer
  - Definition
    - It specifies the maximum number of transaction simultaneously accessing the page.
  - It can use the value from 1 to 32.
  - If it is omitted, the default value is 8.

### <segment attr clause>

It specifies the information for the index storage space.

- INITIAL integer
  - Definition

- It specifies the size of physical storage space which is initially allocated when creating the index.
    - This size is aligned to the EXTENT size of the TABLESPACE to which the table belongs. (e.g. If the EXT size is 8192 bytes, 'INITIAL 100' is actually operated as 8192 bytes. )
    - The size (aligned to the EXTENT size of TABLESPACE) should be equal to or bigger than MIN EXTENTS, or it should be equal to or less than MAXEXTENTS.
  - The minimum value is 1, and the maximum value depends on the system environment.
  - If it is omitted, the default value is one EXTENT size of TABLESPACE to which the table belongs.
- NEXT integer
  - Definition
    - It specifies the physical space size to be allocated when adding the space to the table.
    - This size is aligned to the EXTENT size of the TABLESPACE to which the table belongs. (e.g. If the EXT size is 8192 bytes, 'NEXT 100' is actually operated as 8192 bytes.)
    - NEXT operates as follows, depending on the remaining space size of the index available currently. (Obtained by subtracting the amount of currently used space from the MAXEXTENTS size)
      - If the remaining space size is 0, then it can not extend the space.
      - If the remaining space size is bigger than 0, but smaller than NEXT, then it allocates the space as big as the remaining space.
      - If the remaining space size is bigger than NEXT, then it allocates the space as big as the NEXT.
  - The minimum value is 1 and the maximum value depends on the system environment.
  - If it is omitted, the default value is one EXTENT size of TABLESPACE to which the index belongs.
- MINSIZE integer
  - Definition
    - It is the minimum space size of the index.
    - The value should be equal to or smaller MAXSIZE.
  - This size is aligned to the EXTENT size of the TABLESPACE to which the index belongs.
  - The minimum value is 1 and the maximum value depends on the system environment.
  - If it is smaller than the size of two EXTENT, it is specified to the size of two EXTENT.
  - If it is omitted, the default value is the size of two EXTENT.
- MAXSIZE integer
  - Definition
    - It is the maximum space size of the index.
    - The value should be equal to or bigger than MINSIZE.
  - This size is aligned to the EXTENT size of the TABLESPACE to which the index belongs.
  - The minimum value is 1 and the maximum value depends on the system environment.
  - If it is omitted, the default value is EXTENT size \* 2147483647(The maximum positive integer of INT32).

## <size clause>

It specifies the file size in byte. (If it is omitted, the default unit is bytes.)

- K: Kilobytes
- M: Megabytes
- G: Gigabytes
- T: Terabytes

## Description

A global secondary index is required to enquire a non-deterministic query.

## Examples

It alters the maximum available size to be used by a global secondary index in the table T1 to 100 MBytes.

```
gSQL> ALTER TABLE T1 ALTER GLOBAL SECONDARY INDEX STORAGE( MAXSIZE 100M );  
Table altered.  
gSQL> COMMIT;  
Commit complete.
```

It alters the INITRANS value and the MAXTRANS value to 2 and 4 each which are to be used by a global secondary index in the table T1

```
gSQL> ALTER TABLE T1 ALTER GLOBAL SECONDARY INDEX INITRANS 2 MAXTRANS 4;  
Table altered.  
gSQL> COMMIT;  
Commit complete.
```

## Compatibility

The SQL standard does not define the concepts of the global secondary index.

## For More Information

Refer to the followings.

- ALTER TABLE name ADD GLOBAL SECONDARY INDEX
- ALTER TABLE name DROP GLOBAL SECONDARY INDEX

## 18.51 ALTER TABLE name DROP CONSTRAINT

### Function

It drops a table constraint.

### Syntax

```
<drop table constraint definition> ::=
    ALTER TABLE table_name
        DROP <constraint object>
        [ <drop behavior> ]
    ;
<constraint object> ::=
    CONSTRAINT constraint_name
    | PRIMARY KEY
    | UNIQUE ( column_name [, ...] )
<drop behavior> ::=
    RESTRICT
    | CASCADE
    | CASCADE CONSTRAINTS
```

### Invocation and Access Rules

One of the following privileges is required to perform <drop table constraint definition>.

- The owner of that constraint
- (ALTER or CONTROL TABLE) ON TABLE for that table
- (ALTER TABLE or CONTROL SCHEMA) ON SCHEMA for the schema to which the table belongs
- ALTER ANY TABLE ON DATABASE

## Syntax Rules and Parameters

### table\_name

It is the table name to be altered.

It can define the schema to which the table belongs, such as schema\_name.table\_name. If schema\_name is omitted, the default schema name of the user performing the statement is used.

### CONSTRAINT constraint\_name

It is the constraint name to be dropped.

### PRIMARY KEY

It is the primary key constraint for the table.

### UNIQUE( column\_name [, ...] )

It is the unique constraint for the columns.

### <drop behavior>

When it is omitted, the default value is RESTRICT.

Currently, RESTRICT/CASCADE is operated in the same way.

## Description

<drop column not null clause> of ALTER TABLE name ALTER COLUMN is used to drop NOT NULL constraint without using the constraint name.

## Examples

The following is an example of dropping a primary key constraint from the table.

```
gSQL> ALTER TABLE t1 DROP PRIMARY KEY;
```

```
Table altered.
```

The following is an example of dropping the table constraint by specifying the constraint name.

```
gSQL> ALTER TABLE t1 DROP CONSTRAINT t1_pk;  
Table altered.
```

## Compatibility

The SQL standard does not define the following clauses.

- DROP PRIMARY KEY
- DROP UNIQUE ( column\_name [, ...] )
- CASCADE CONSTRAINTS

**Table 18-18** SQL standard compatibility

Feature ID	Description	Compatibility
F381	Extended schema manipulation	O

## For More Information

Refer to the followings.

- ALTER TABLE
- ALTER TABLE name ADD CONSTRAINT
- DROP INDEX

## 18.52 ALTER TABLE name DROP GLOBAL SECONDARY INDEX

### Function

It drops a global secondary index from the table.

### Syntax

```
<alter table drop global secondary index definition> ::=  
    ALTER TABLE table_name  
        DROP GLOBAL SECONDARY INDEX  
    ;
```

### Invocation and Access Rules

<alter table drop global secondary index definition> statement can be defined in a cluster system, and the user should satisfy the following conditions.

- The following privilege for the table from which the index is to be dropped is required
  - (ALTER or CONTROL TABLE) ON TABLE for that table
  - (ALTER TABLE or CONTROL SCHEMA) ON SCHEMA for the schema to which the table belongs
  - ALTER ANY TABLE ON DATABASE

### Syntax Rules and Parameters

#### table\_name

It is the name of a table from which the index is to be dropped.



## Description

A global secondary index is required to enquire a non-deterministic query.

## Examples

It drops a global secondary index from the table T1.

```
gSQL> ALTER TABLE T1 DROP GLOBAL SECONDARY INDEX;  
Table altered.  
gSQL> COMMIT;  
Commit complete.
```

## Compatibility

The SQL standard does not define the concepts of the global secondary index.

## For More Information

Refer to the followings.

- ALTER TABLE name ADD GLOBAL SECONDARY INDEX
- ALTER TABLE name ALTER GLOBAL SECONDARY INDEX

## 18.53 ALTER TABLE name DROP SUPPLEMENTAL LOG

### Function

It sets not to leave the primary key information on the redo log when changing the data in the table.

### Syntax

```
<add table supplemental log statement> ::=  
ALTER TABLE table_name  
    DROP SUPPLEMENTAL LOG DATA ( PRIMARY KEY ) COLUMNS  
;
```

### Invocation and Access Rules

One of the following privileges is required to perform <drop table supplemental log statement>.

- (ALTER or CONTROL TABLE) ON TABLE for that table
- (ALTER TABLE or CONTROL SCHEMA) ON SCHEMA for the schema to which the table belongs
- ALTER ANY TABLE ON DATABASE

### Syntax Rules and Parameters

#### table\_name

It is the table name to be altered.

It can define the schema to which the table belongs, such as schema\_name.table\_name. If schema\_name is omitted, the default schema name of the user performing the statement is used.

It should have been set by using **ALTER TABLE name ADD SUPPLEMENTAL LOG** statement.

## Description

For more information, refer to the rules for each syntax.

## Example

The following is an example of setting not to leave the primary key information on the redo log when changing the data in the table.

```
gSQL> ALTER TABLE t1 DROP SUPPLEMENTAL LOG DATA ( PRIMARY KEY ) COLUMNS;  
Table altered.
```

## Compatibility

The SQL standard does not cover <drop table supplemental log statement>.

## 18.54 ALTER TABLE name MERGE SHARDS

### Function

It merges specific shards in a table in a cluster environment, and rebalances them.

### Syntax

```
<alter table merge shards statement> ::=  
    ALTER TABLE table_name MERGE SHARDS <source shard list>  
        INTO dest_shard_name [ <dest shard placement> ]  
    ;  
<source shard list> ::=  
    source_shard_name [ , ... ]  
    | start_shard_name TO end_shard_name  
<dest shard placement> ::=  
    AT CLUSTER GROUP dest_group_name
```

### Invocation and Access Rules

It can be performed in the cluster system.

One of the following privilege is required to perform <alter table merge shards statement>.

- (ALTER or CONTROL TABLE) ON TABLE for that table
- (ALTER TABLE or CONTROL SCHEMA) ON SCHEMA for the schema to which the table belongs
- ALTER ANY TABLE ON DATABASE

### Syntax Rules and Parameters

#### table\_name

It is the name of a table.

It can define a schema to which the table belongs such as schema\_name.table\_name. If schema\_name is

omitted, the default schema name of the user performing the statement is used.

The statement can be performed only when the table is a cluster-specific, and a list shard or a range shard.

## ⟨source shard list⟩

It is the list of original shards to be merged.

The shard specified by a list should exist in the table.

## source\_shard\_name

It is the name of an original shard to be merged.

If the shard does not exist in the table, then the statement can not be performed.

## start\_shard\_name

It is the name of the first shard in the range of merging.

It is used only in a range shard.

## end\_shard\_name

It is the name of the last shard in the range of merging.

It is used only in a range shard.

## dest\_shard\_name

It is the name of a target shard.

## ⟨dest shard placement⟩

It is the name of a cluster group in which the target shard is to be placed.

If the corresponding clause is omitted, *dest\_shard\_name* should be included in ⟨source shard list⟩.

## Description

It merges specific shards in a specific table, then places them in an arbitrary cluster group.

- It can not be performed in a standalone database.

- It can not be performed in a hash sharded table nor in a cloned table.
- It can not be performed in a table created as cluster wide.
- DML can not be performed for source shards while merging is in progress.
- If it is a range shard, the beginning and ending original shards to be merged can be defined.
- Original shards to be merged can be listed in a range shard or a list shard.

In this case, shards listed in a range shard should be the neighboring shard.

The following is an error which occurred when merging shards which are not neighboring in a range sharded table in a way of listing.

```
CREATE TABLE t1( i1 INTEGER )
  SHARDING BY RANGE (i1)
  SHARD shard1 VALUES LESS THAN ( 200 )      AT CLUSTER GROUP G1,
  SHARD shard2 VALUES LESS THAN ( 400 )      AT CLUSTER GROUP G2,
  SHARD shard3 VALUES LESS THAN ( MAXVALUE ) AT CLUSTER GROUP G3
;
Table created.
ALTER TABLE t1 MERGE SHARDS shard1, shard3 INTO shard4 AT CLUSTER GROUP G2;
ERR-42000(16488): shards being merged are not adjacent :
ALTER TABLE t1 MERGE SHARDS shard1, shard3 INTO shard4 AT CLUSTER GROUP G2
*
ERROR at line 1:
```

## Examples

The following is an example of merging shards in a way of listing.

```
gSQL> ALTER TABLE t1 MERGE SHARDS shard1, shard2, shard3 INTO shard4 AT CLUSTER GROUP G2;
Table altered
```

The following is an example of merging shards in a way of ranging.

```
gSQL> ALTER TABLE t1 MERGE SHARDS shard1 TO shard3 INTO shard4 AT CLUSTER GROUP G2;
Table altered
```

## Compatibility

The SQL standard does not define the concepts of the cluster.

## For More Information

Refer to the followings.

- ALTER TABLE name MOVE SHARD
- ALTER TABLE name SPLIT SHARD

## 18.55 ALTER TABLE name MOVE SHARD

### Function

It rebalances a specific shard of a table, or the entire shard in a specific cluster group to a specific cluster group.

### Syntax

```
<alter table move shard statement> ::=  
    ALTER TABLE table_name MOVE SHARD  
        { shard_name_list | FROM CLUSTER GROUP src_cluster_group }  
        TO CLUSTER GROUP dest_cluster_group [ ONLINE | OFFLINE ]  
    ;
```

### Invocation and Access Rules

It can be performed in a cluster system.

One of the following privileges is required to perform <alter table move shard statement>.

- (ALTER or CONTROL TABLE) ON TABLE for that table
- (ALTER TABLE or CONTROL SCHEMA) ON SCHEMA for the schema to which the table belongs
- ALTER ANY TABLE ON DATABASE

### Syntax Rules and Parameters

#### table\_name

It is the table name.

It can define a schema to which the table belongs such as schema\_name.table\_name.

If schema\_name is omitted, the default schema name of the user performing the statement is used.

The statement can be performed only when that table is a cluster group specific table.



## shard\_name\_list

It is the shard name list to be rebalanced.

If the shard does not exist in that table, then the statement can not be performed.

## src\_cluster\_group

It is the name of a specific cluster group to be rebalanced.

## dest\_cluster\_group

It is the name of a target cluster group on which the shard of the table is to be rebalanced.

If the cluster group specified by the shard of that table already exists then the statement can not be performed.

## [ ONLINE | OFFLINE ]

It determines whether to allow DML when rebalancing table shard.

- ONLINE
  - It allows INSERT, UPDATE, and DELETE.
- OFFLINE
  - It does not allow INSERT, UPDATE, DELETE.
- When it is omitted, the default value is ONLINE.

## Description

It rebalances a specific shard of the table from a specific cluster group to another cluster group.

To drop a specific cluster group, rebalance the shard of the table then perform the **DROP CLUSTER GROUP** statement.

To move shards of all tables from a specific cluster group to another cluster group, then perform the **ALTER DATABASE MOVE SHARD FROM CLUSTER GROUP TO CLUSTER GROUP** statement.

If it is a **CLONED** table or a **CLUSTER WIDE** table, then an error occurs and it fails.

## Examples

The following is an example of executing the `<alter table move shard statement>` statement.

```
gSQL> ALTER TABLE t1 MOVE SHARD shard1, shard2 TO CLUSTER GROUP g3;
Table altered.
gSQL> ALTER TABLE t1 MOVE SHARD FROM CLUSTER GROUP g1 TO CLUSTER GROUP g3;
Table altered.
```

The following is an example of which a CLONED table and a CLUSTER WIDE table fails to move shard.

```
gSQL> CREATE TABLE T1 ( C1 INTEGER ) SHARDING BY RANGE (C1)
      AT CLUSTER WIDE
      SHARD s1 VALUES LESS THAN (10),
      SHARD s2 VALUES LESS THAN (MAXVALUE);
Table created.
gSQL> ALTER TABLE T1 MOVE SHARD s1 TO CLUSTER GROUP g2;
ERR-42000(16440): cannot execute on cluster wide sharded tables
gSQL> CREATE TABLE T2 ( C1 INTEGER ) CLONED AT CLUSTER GROUP g1, g2;
Table created.
gSQL> ALTER TABLE T2 MOVE SHARD FROM CLUSTER GROUP g1 TO CLUSTER GROUP g3;
ERR-42000(16437): cannot execute on cloned tables
```

## Compatibility

The SQL standard does not define the concepts of the cluster.

## For More Information

Refer to **ALTER DATABASE MOVE SHARD**.

## 18.56 ALTER TABLE name READ { ONLY | WRITE }

### Function

It sets READ { ONLY | WRITE } in a table.

### Syntax

```
<alter table read { only | write } statement> ::=  
    ALTER TABLE table_name  
        READ { ONLY | WRITE }  
    ;
```

### Invocation and Access Rules

One of the following privileges is required to perform <alter table read { only | write } statement>.

- (ALTER or CONTROL TABLE) ON TABLE for that table
- (ALTER TABLE or CONTROL SCHEMA) ON SCHEMA for the schema to which the table belongs
- ALTER ANY TABLE ON DATABASE

### Syntax Rules and Parameters

#### table\_name

It is the table name.

It can define a schema to which the table belongs such as schema\_name.table\_name.

If schema\_name is omitted, the default schema name of the user performing the statement is used.

## Description

It sets table property to READ { ONLY | WRITE }.

If it is set to READ ONLY, neither SELECT .. FOR UPDATE statement, nor DML/ DDL statement which updates table data can be used. However, DDL statement which does not update the table data is allowed.



Disallowed SQL statements when it is set to READ ONLY

- INSERT, UPDATE, DELETE
- TRUNCATE
- SELECT .. FOR UPDATE
- ALTER TABLE RENAME/DROP COLUMN
- ALTER TABLE SET COLUMN UNUSED

Allowed SQL statements when it is set to READ ONLY

- SELECT
- CREATE/ALTER/DROP INDEX
- ALTER TABLE ADD/ALTER COLUMN
- ALTER TABLE ADD/ALTER/RENAME/DROP CONSTRAINT
- ALTER TABLE for physical property changes
- ALTER TABLE DROP UNUSED COLUMNS
- ALTER TABLE RENAME TO
- DROP TABLE
- ALTER TABLE ADD/DROP SUPPLEMENTAL LOG
- LOCK TABLE

## Examples

The following is an example of executing <alter table read { only | write } statement>.

```
gSQL> ALTER TABLE t1 READ ONLY;  
Table altered.  
gSQL> ALTER TABLE t1 READ WRITE;  
Table altered.
```

## Compatibility

The SQL standard does not define <alter table read { only | write } statement>.

## For More Information

Refer to ALTER TABLE.

## 18.57 ALTER TABLE name REBALANCE

### Function

It rebalances the shard in a table.

### Syntax

```
<alter table rebalance statement> ::=  
    ALTER TABLE table_name REBALANCE [ ONLINE | OFFLINE ]  
    ;
```

### Invocation and Access Rules

It can be performed in a cluster system.

One of the following privileges is required to perform <alter table rebalance statement>.

- (ALTER or CONTROL TABLE) ON TABLE for that table
- (ALTER TABLE or CONTROL SCHEMA) ON SCHEMA for the schema to which the table belongs
- ALTER ANY TABLE ON DATABASE

### Syntax Rules and Parameters

#### table\_name

It is the table name.

It can define the schema to which the table belongs, such as schema\_name.table\_name. If schema\_name is omitted, the default schema name of the user performing the statement is used.

#### [ ONLINE | OFFLINE ]

It determines whether to allow DML when rebalancing table shard.

- ONLINE
  - It allows INSERT, UPDATE, and DELETE.
- OFFLINE
  - It does not allow INSERT, UPDATE, DELETE.
- When it is omitted, the default value is ONLINE.

## Description

It does not rebalance shards in a table when adding a cluster member or a cluster group by using the following statements.

- **CREATE CLUSTER GROUP**
- **ALTER CLUSTER GROUP name ADD MEMBER**

To rebalance the shards of a table in the added cluster group and the cluster member, perform the `<alter table rebalance statement>` statement. The operation succeeds without a separate rebalancing if the shard of the table is already rebalanced.

To rebalance shards in all tables, perform the **ALTER DATABASE REBALANCE** statement.

## Examples

The following is an example of executing the `<alter table rebalance statement>` statement.

```
gSQL> ALTER TABLE t1 REBALANCE;  
Table altered.
```

## Compatibility

The SQL standard does not define the concepts of the cluster.

## 18.58 ALTER TABLE name REBALANCE EXCLUDE CLUSTER GROUP cluster\_group\_list

### Function

It rebalances the shard of the table not to include a shard in a specific cluster group.

### Syntax

```
<alter table rebalance exclude cluster group statement> ::=  
    ALTER TABLE table_name REBALANCE  
        EXCLUDE CLUSTER GROUP cluster_group_list [ ONLINE | OFFLINE ]  
    ;
```

### Invocation and Access Rules

It can be performed in a cluster system.

One of the following privileges is required to perform <alter table rebalance exclude cluster group statement>.

- (ALTER or CONTROL TABLE) ON TABLE for that table
- (ALTER TABLE or CONTROL SCHEMA) ON SCHEMA for the schema to which the table belongs
- ALTER ANY TABLE ON DATABASE

### Syntax Rules and Parameters

#### table\_name

It is the table name.

It can define a schema to which the table belongs such as schema\_name.table\_name.

If schema\_name is omitted, the default schema name of the user performing the statement is used.

The statement can be performed only when that table is a cluster-wide table.



## cluster\_group\_list

It is a list of the cluster group which does not include a shard of a table.

If the cluster group to be excluded from the rebalancing is the entire group, the statement can not be performed.

## [ ONLINE | OFFLINE ]

It determines whether to allow DML when rebalancing table shard.

- ONLINE
  - It allows INSERT, UPDATE, and DELETE.
- OFFLINE
  - It does not allow INSERT, UPDATE, DELETE.
- When it is omitted, the default value is ONLINE.

## Description

It excludes a specific cluster group and rebalances the shard of the table.

If the shard of the table does not exist in that cluster group, the operation succeeds without a separate rebalancing.

It rebalances the shard based on the cluster group in which the shard of the table is located.

To drop a specific cluster group, rebalance the shard of the table and perform **DROP CLUSTER GROUP** statement.

To rebalance the shard excluding a cluster group from all tables, perform the **ALTER DATABASE REBALANCE EXCLUDE CLUSTER GROUP** statement.

## Examples

The following is an example of executing the <alter table rebalance exclude cluster group statement> statement.

```
gSQL> ALTER TABLE t1 REBALANCE EXCLUDE CLUSTER GROUP g3;  
Table altered.
```

## Compatibility

The SQL standard does not define the concepts of the cluster.

# 18.59 ALTER TABLE name REBUILD GLOBAL SECONDARY INDEX

## Function

It rebuilds a global secondary index

## Syntax

```

<rebuild global secondary index statement> ::=
    ALTER TABLE table_name REBUILD GLOBAL SECONDARY INDEX
        [ ONLINE | OFFLINE ]
        [ <index attributes> [...] ]
        [ TABLESPACE tablespace_name ]
    ;
<index attributes> ::=
    <physical attribute clause>
    | STORAGE ( <segment attr clause> [...] )
    | <parallel clause>
<physical attribute clause> ::=
    PCTFREE integer
    | INITTRANS integer
    | MAXTRANS integer
<segment attr clause> ::=
    INITIAL <size_clause>
    | NEXT <size_clause>
    | MINSIZE <size_clause>
    | MAXSIZE <size_clause>
<size clause> ::=
    integer [ K | M | G | T ]
<parallel clause> ::=
    NOPARALLEL
    | PARALLEL [ integer ]

```

## Invocation and Access Rules

The user should satisfy the following conditions to perform `<rebuild global secondary index statement>`.

- One of the following privileges is required for the table on which the index is to be rebuilt.
  - (ALTER or CONTROL TABLE) ON TABLE for the table
  - (ALTER TABLE or CONTROL SCHEMA) ON SCHEMA for the schema to which the table belongs
  - ALTER ANY TABLE ON DATABASE
- One of the following privileges is required for the tablespace on which the index is to be rebuilt.
  - CREATE OBJECT ON TABLESPACE for the tablespace
  - USAGE TABLESPACE ON DATABASE

## Syntax Rules and Parameters

### table\_name

It is the table name on which the index is to be rebuilt.

It can define the schema to which the table belongs, such as `schema_name.table_name`. If `schema_name` is omitted, the default schema name of the user performing the statement is used.

### [ ONLINE | OFFLINE ]

It determines whether to allow DML on the table when rebuilding the index.

- ONLINE
  - It allows INSERT, UPDATE, and DELETE.
- OFFLINE
  - It does not allow INSERT, UPDATE, DELETE.
- When it is omitted, the default value is ONLINE.

### <physical attribute clause>

It defines the physical attribute information of an index.

- PCTFREE integer
  - Definition
    - It is the reserved space for adjusting the page split frequency caused by the key inserted in the page.

- It can use the value from 0 to 99.
- If it is omitted, the default value is the value set in the existing index.
- INITRANS integer
  - Definition
    - It specifies the initial number of transactions which can simultaneously access the page.
    - If the number of users who access the index is small, INITRANS is set to low, and if the number of users who simultaneously access the index is big, INITRANS is set to high.
    - If necessary, it is automatically increased to the specified MAXTRANS.
  - It can use the value from 1 to 32.
  - If it is omitted, the default value is the value set in the existing index.
- MAXTRANS integer
  - Definition
    - It specifies the maximum number of transactions which can simultaneously access the page.
  - It can use the value from 1 to 32.
  - If it is omitted, the default value is the value set in the existing index.

## ⟨segment attr clause⟩

It specifies the information for the index storage space.

- INITIAL integer
  - Definition
    - It specifies the size of physical storage space which is initially allocated when creating the index.
    - This size is aligned to the EXTENT size of the TABLESPACE to which the table belongs. (e.g. If the EXT size is 8192 bytes, 'INITIAL 100' is actually operated as 8192 bytes. )
    - The size (aligned to the EXTENT size of TABLESPACE) should be equal to or bigger than MIN EXTENTS, or it should be equal to or less than MAXEXTENTS.
  - The minimum value is 1, and the maximum value depends on the system environment.
  - If it is omitted, the default value is the value set in the existing index.
- NEXT integer
  - Definition
    - It specifies the physical space size to be allocated when adding the space to the table.
    - This size is aligned to the EXTENT size of the TABLESPACE to which the table belongs. (e.g. If the EXT size is 8192 bytes, 'NEXT 100' is actually operated as 8192 bytes.)
    - NEXT operates as follows, depending on the remaining space size of the index available currently. (Obtained by subtracting the amount of currently used space from the MAXEXTENTS size)
  - If the remaining space size is 0, then it can not extend the space.
  - If the remaining space size is bigger than 0, but smaller than NEXT, then it allocates the

space as big as the remaining space.

- If the remaining space size is bigger than NEXT, then it allocates the space as big as the NEXT.

- The minimum value is 1 and the maximum value depends on the system environment.
- If it is omitted, the default value is the value set in the existing index.
- MINSIZE integer
  - Definition
    - It is the minimum space size of the index.
    - The value should be equal to or smaller MAXSIZE.
  - This size is aligned to the EXTENT size of the TABLESPACE to which the index belongs.
  - The minimum value is 1 and the maximum value depends on the system environment.
  - If it is smaller than the size of two EXTENT, it is specified to the size of two EXTENT.
  - If it is omitted, the default value is the value set in the existing index.
- MAXSIZE integer
  - Definition
    - It is the maximum space size of the index.
    - The value should be equal to or bigger than MINSIZE.
  - This size is aligned to the EXTENT size of the TABLESPACE to which the index belongs.
  - The minimum value is 1 and the maximum value depends on the system environment.
  - If it is omitted, the default value is the value set in the existing index.

## ⟨size clause⟩

It specifies the file size in bytes. (If the unit is omitted, the default value is bytes.)

- K: Kilobytes
- M: Megabytes
- G: Gigabytes
- T: Terabytes

## NOPARALLEL | PARALLEL [ integer ]

It specifies the number of threads to be used when rebuilding an index.

- NOPARALLEL
  - It does not rebuild an index in parallel.
- PARALLEL [integer]
  - It rebuilds an index in parallel.
  - If an integer is omitted or set as 0, then it follows INDEX\_BUILD\_PARALLEL\_FACTOR property.
  - The minimum value of an integer is 0 and the maximum value is 64.
  - If the integer or the property value is 0, then the system determines the optimal value.

- If it is omitted, the default value is NOPARALLEL.

## TABLESPACE tablespace\_name

It specifies the name of the tablespace in which the index is to be rebuilt.

- When it specifies tablespace\_name
  - if tablespace\_name is data tablespace, then it is rebuilt as a LOGGING index.
  - if tablespace\_name is temporary tablespace or nologging tablespace, then it is rebuilt as a NOLOGGING index.
- When TABLESPACE clause is omitted, then it is set to the tablespace of the existing index.

## Description

- Dropping the index fragmentation
  - The fragmentation may occur on the index page, when update DML is frequently performed in the index. If the tree becomes too big comparing to the valid data, then the index volume becomes larger and the performance is degraded. In this case, rebuilding the index can solve the index fragmentation issue so that the index volume is reduced and the index performance is recovered.
- Altering the tablespace in the index
  - The tablespace in the previously created index can be altered.
  - However, LOGGING should be set properly according to whether the tablespace is TEMPORARY or not.
- Altering LOGGING setting in the index
  - The LOGGING setting in the previously created index can be altered by using TABLESPACE option.
  - The data tablespace should be set in TABLESPACE option to switch to the LOGGING index.
  - The temporary tablespace or the nologging tablespace should be set in TABLESPACE option to switch to the NOLOGGING index.

## Examples

Rebuild the global secondary index in the table T1.

```
gSQL> ALTER TABLE T1 REBUILD GLOBAL SECONDARY INDEX;
```

Alter the tablespace and logging settings of the global secondary index in the table T1.

```
gSQL> ALTER TABLE T1 REBUILD GLOBAL SECONDARY INDEX TABLESPACE MEM_DATA_TBS;  
gSQL> ALTER TABLE T1 REBUILD GLOBAL SECONDARY INDEX TABLESPACE MEM_TEMP_TBS;
```

## Compatibility

The SQL standard does not cover the concepts of the global secondary index.

## For More Information

Refer to the followings.

- `ALTER TABLE name ADD GLOBAL SECONDARY INDEX`
- `ALTER TABLE name DROP GLOBAL SECONDARY INDEX`
- `ALTER INDEX name REBUILD`



## 18.60 ALTER TABLE name RENAME COLUMN

### Function

It renames the table column.

### Syntax

```
<rename column statement> ::=  
    ALTER TABLE table_name  
        RENAME COLUMN old_column_name TO new_column_name  
    ;
```

### Invocation and Access Rules

One of the following privileges is required to perform <rename column statement>.

- (ALTER or CONTROL TABLE) ON TABLE for that table
- (ALTER TABLE or CONTROL SCHEMA) ON SCHEMA for the schema to which the table belongs
- ALTER ANY TABLE ON DATABASE

### Syntax Rules and Parameters

#### table\_name

It is the table name to be altered.

It can define the schema to which the table belongs, such as schema\_name.table\_name. If schema\_name is omitted, the default schema name of the user performing the statement is used.

#### old\_column\_name

It is the old column name to be altered.

## new\_column\_name

It is the new column name to be altered.

The same column name should not exist in a table.

## Description

Even when the column name is altered it does not require the object change such as index, constraint which is generated based on the previous column.

## Example

The following is an example of exchanging the names of two columns, col\_1 and col\_2.

```
gSQL> ALTER TABLE t1 RENAME COLUMN col_1 TO col_temp;
Table altered.
gSQL> ALTER TABLE t1 RENAME COLUMN col_2 TO col_1;
Table altered.
gSQL> ALTER TABLE t1 RENAME COLUMN col_temp TO col_2;
Table altered.
gSQL> COMMIT;
Commit complete.
```

## Compatibility

The SQL standard does not define <rename column statement>.

## For More Information

Refer to the followings.

- ALTER TABLE
- ALTER TABLE name ADD COLUMN
- ALTER TABLE name SET UNUSED COLUMN
- ALTER TABLE name ALTER COLUMN

## 18.61 ALTER TABLE name RENAME CONSTRAINT

### Function

It renames the table constraints.

### Syntax

```
<rename table constraint statement> ::=  
    ALTER TABLE table_name  
        RENAME <constraint object> TO new_constraint_name  
    ;  
<constraint object> ::=  
    CONSTRAINT constraint_name  
    | PRIMARY KEY  
    | UNIQUE ( column_name [, ...] )
```

### Invocation and Access Rules

One of the following privileges is required to perform <rename table constraint statement>.

- (ALTER or CONTROL TABLE) ON TABLE for that table
- (ALTER TABLE or CONTROL SCHEMA) ON SCHEMA for the schema to which the table belongs
- ALTER ANY TABLE ON DATABASE

### Syntax Rules and Parameters

#### table\_name

It is the table name to be altered.

It can define the schema to which the table belongs, such as schema\_name.table\_name. If schema\_name is omitted, the default schema name of the user performing the statement is used.

## <constraint object>

The existing name of the constraint to be altered is specified as follows.

- CONSTRAINT constraint\_name
  - The constraint name to be altered
- PRIMARY KEY
  - PRIMARY KEY constraint of the table
- UNIQUE( column [,...] )
  - UNIQUE constraint which satisfies the column list

## new\_column\_name

It is the new name of a constraint to be altered.

## Description

The index name which was automatically created with a key constraint such as primary key, unique key is not altered. Use **ALTER INDEX name RENAME TO** statement to rename the index.

## Examples

The following is an example of renaming the primary key constraint of the table.

```
gSQL> ALTER TABLE t1 RENAME PRIMARY KEY TO pk_t1;  
Table altered.
```

The following is an example of renaming the table constraint by specifying the constraint name.

```
gSQL> ALTER TABLE t1 RENAME CONSTRAINT pk_t1 TO t1_pk;  
Table altered.
```

## Compatibility

The SQL standard does not define the <rename table constraint statement> statement.

## For More Information

Refer to the followings.

- ALTER TABLE
- ALTER TABLE name ADD CONSTRAINT
- ALTER TABLE name DROP CONSTRAINT
- ALTER TABLE name ALTER CONSTRAINT

## 18.62 ALTER TABLE name RENAME SHARD

### Function

It renames a specific shard of a table in cluster environment.

### Syntax

```
<alter table rename shard statement> ::=  
    ALTER TABLE table_name  
        RENAME SHARD shard_name TO new_shard_name  
    ;
```

### Invocation and Access Rules

It can be performed in a cluster system.

One of the following privileges is required to perform <alter table rename shard statement>.

- (ALTER or CONTROL TABLE) ON TABLE for that table
- (ALTER TABLE or CONTROL SCHEMA) ON SCHEMA for the schema to which the table belongs
- ALTER ANY TABLE ON DATABASE

### Syntax Rules and Parameters

#### table\_name

It is the table name to be altered.

It can define a schema to which the table belongs such as schema\_name.table\_name.

If schema\_name is omitted, the default schema name of the user performing the statement is used.

## shard\_name

It is the existing name of a shard to be altered.

If the shard does not exist in that table, then the statement can not be performed.

## new\_shard\_name

It is the new name of a shard to be altered.

The same shard name should not exist in the table.

## Description

It alters the name of a specific shard of a hash, a range, or a list table. This statement can not be performed for a cloned table.

## Examples

The following is an example of executing <alter table rename shard statement> statement.

```
gSQL> ALTER TABLE t_range RENAME SHARD r_01 TO r_new_01;
Table altered.
gSQL> ALTER TABLE t_list RENAME SHARD l_01 TO l_new_01;
Table altered.
gSQL> ALTER TABLE t_hash RENAME SHARD shard_000000 TO h_new_00;
Table altered.
gSQL> COMMIT;
Commit complete.
```

## Compatibility

The SQL standard does not define the concepts of the cluster.

## For More Information

Refer to the followings.

- ALTER TABLE
- ALTER TABLE name MOVE SHARD
- ALTER TABLE name SPLIT SHARD
- ALTER TABLE name REBALANCE



## 18.63 ALTER TABLE name RENAME TO

### Function

It renames the table.

### Syntax

```
<rename table statement> ::=  
    ALTER TABLE table_name  
        RENAME TO new_table_name  
    ;
```

### Invocation and Access Rules

One of the following privileges is required to perform <rename table statement>.

- (ALTER or CONTROL TABLE) ON TABLE for that table
- (ALTER TABLE or CONTROL SCHEMA) ON SCHEMA for the schema to which the table belongs
- ALTER ANY TABLE ON DATABASE

### Syntax Rules and Parameters

#### table\_name

It is the existing name of the table.

It can define the schema to which the table belongs, such as schema\_name.table\_name. If schema\_name is omitted, the default schema name of the user performing the statement is used.

#### new\_table\_name

It is a new name of the table.

The same table name should not exist in the schema.

## Description

Even when the table is renamed, the object referring to the table such as index, constraint does not need to be renamed.

## Example

The following is an example of exchanging the name of the two tables t1, t2.

```
gSQL> ALTER TABLE t1 RENAME TO t_temp;
Table altered.
gSQL> ALTER TABLE t2 RENAME TO t1;
Table altered.
gSQL> ALTER TABLE t_temp RENAME TO t2;
Table altered.
gSQL> COMMIT;
Commit complete.
```

## Compatibility

The SQL standard does not define <rename table statement>.

## For More Information

Refer to **ALTER TABLE**.

## 18.64 ALTER TABLE name SET UNUSED COLUMN

### Function

It drops a table column.

### Syntax

```
<drop column definition> ::=
    ALTER TABLE table_name <drop column clause>
    ;
<drop column clause> ::=
    SET UNUSED [ COLUMN ] <column_name_list> [ <drop behavior> ]
<column name list> ::=
    column_name
    | ( column_name [, ...] )
<drop behavior> ::=
    RESTRICT
    | CASCADE
    | CASCADE CONSTRAINTS
```

### Invocation and Access Rules

One of the following privileges is required to perform <drop column definition>.

- (ALTER or CONTROL TABLE) ON TABLE for that table
- (ALTER TABLE or CONTROL SCHEMA) ON SCHEMA for the schema to which the table belongs
- ALTER ANY TABLE ON DATABASE

### Syntax Rules and Parameters

## **table\_name**

It is the table name to be altered.

It can define the schema to which the table belongs, such as `schema_name.table_name`. If `schema_name` is omitted, the default schema name of the user performing the statement is used.

## **SET UNUSED [ COLUMN ]**

It sets the column not to be used.

## **column\_name\_list**

One or more column names to be dropped.

- e.g. `ALTER TABLE t1 SET UNUSED COLUMN c1`
- e.g. `ALTER TABLE t1 SET UNUSED COLUMN (c1, c2)`

## **column\_name**

It is the column name to be dropped.

It also drops the constraints and indexes which use the column.

## **drop behavior**

When it is omitted, the default value is `RESTRICT`.

Currently, `RESTRICT/CASCADE` is operated in the same way.

## **Description**

`SET UNUSED COLUMN` does not delete the data physically, so it ensures consistent performance regardless of the number of the rows.

## **Example**

The following is an example of setting the column not to be used.

```
gSQL> ALTER TABLE t1 SET UNUSED COLUMN ( addr );  
Table altered.
```

## Compatibility

The SQL standard does not define the following clauses.

- SET UNUSED
- CASCADE CONSTRAINTS
- Listing multiple columns

**Table 18-19** SQL standard compatibility

Feature ID	Description	Compatibility
F033	ALTER TABLE statement: DROP COLUMN clause	X

## For More Information

Refer to the followings.

- ALTER TABLE
- ALTER TABLE name ADD COLUMN
- ALTER TABLE name ALTER COLUMN
- ALTER TABLE name RENAME COLUMN

## 18.65 ALTER TABLE name SPLIT SHARD

### Function

It rebalances a specific shard of a table by splitting it in a cluster environment.

### Syntax

```

<alter table split shard statement> ::=
    ALTER TABLE table_name SPLIT SHARD source_shard_name
        INTO ( <split shard placement> [, ...] )
    ;
<split shard placement> ::=
    <split shard bound def> AT CLUSTER GROUP dest_group_name
<split shard bound def> ::=
    <split list shard def>
    | <split range shard def>
<split list shard def> :=
    SHARD dest_shard_name VALUES IN ( <split list value clause> )
<split list value clause> :=
    <split list value> [, ...]
<split list value> :=
    constant
    | NULL
<split range shard def> :=
    SHARD dest_shard_name VALUES LESS THAN ( <split range value clause> )
<split range value clause> :=
    <split range value> [, ...]
<split range value> :=
    constant
  
```

### Invocation and Access Rules

It can be performed in a cluster system.

One of the following privileges is required to perform <alter table split shard statement>.

- (ALTER or CONTROL TABLE) ON TABLE for that table
- (ALTER TABLE or CONTROL SCHEMA) ON SCHEMA for the schema to which the table belongs
- ALTER ANY TABLE ON DATABASE

## Syntax Rules and Parameters

### table\_name

It is the table name.

It can define a schema to which the table belongs such as schema\_name.table\_name.

If schema\_name is omitted, the default schema name of the user performing the statement is used.

The statement can be performed only when that table is a cluster group specific table, and when the shard is a list shard or a range shard.

### source\_shard\_name

It is the name of an original shard to be splitted.

If the shard does not exist in that table, the statement can not be performed.

### <split shard placement>

It defines the target shard to which the original shard is rebalanced by splitting.

### <split shard bound def>

It defines the bound of a target shard to be splitted.

It can be defined as one of two following bound defs.

- <split list shard def>
- <split range shard def>

### <split list shard def>

It defines a split shard bound for a list shard.

- dest\_shard\_name
  - It is the name of a target shard.

- `<split list value clause>`
  - `<split list value>` should be an integer.
  - `<split list value>` can not be NULL.
  - `<split list value>` can not be DEFAULT.
  - `S1 : ( 1, 11, 21, 31, NULL ) SPLIT SHARD S1 INTO ( <split list value clause> .. )`
    - (O) SHARD S11 VALUES IN ( 1 )
    - (O) SHARD S11 VALUES IN ( 1, NULL )
    - (O) SHARD S11 VALUES IN ( 1, 11, 21, 31 )
    - (X) SHARD S11 VALUES IN ( 2 )
    - (X) SHARD S11 VALUES IN ( DEFAULT )
    - (X) SHARD S11 VALUES IN ( 1, 11, 21, 31, NULL )

### `<split range shard def>`

It defines a split shard bound for a range shard.

- `<split range value clause>`
  - `<split list value>` should be an integer.
  - `<split list value>` can not be NULL.
  - `<split list value>` can not be MAXVALUE.
  - `S1 : ( 100, 100 ), S2 : ( 50, 50 ) SPLIT SHARD S1 INTO ( <split range value clause> .. )`
    - (O) SHARD S11 VALUES IN ( 50, 100 )
    - (O) SHARD S11 VALUES IN ( 100, 50 )
    - (O) SHARD S11 VALUES IN ( 60, 60 )
    - (X) SHARD S11 VALUES IN ( 50, NULL )
    - (X) SHARD S11 VALUES IN ( 50, 50 )
    - (X) SHARD S11 VALUES IN ( 100, 100 )
    - (X) SHARD S11 VALUES IN ( 100, 110 )
    - (X) SHARD S11 VALUES IN ( MAXVALUE, 100 )

### `dest_group_name`

It is the name of a cluster group in which the splitted shard is to be rebalanced.

## Description

It splits a specific shard of a specific table and rebalances it to a random cluster group.

This is used to distribute records and loads by splitting the shards when records corresponding to a specific shard is too much or when a specific group member is overloaded.



## Examples

The following is an example of executing the <alter table split shard statement> statement.

```
gSQL> ALTER TABLE t1 SPLIT SHARD shard1 INTO ( SHARD shard11 VALUES IN ( 11 ) AT CLUSTER GROUP G2 );
```

Table altered.

```
gSQL> ALTER TABLE t1 SPLIT SHARD shard1 INTO ( SHARD shard11 VALUES LESS THAN ( 11 ) AT CLUSTER GROUP G2 );
```

Table altered.

## Compatibility

The SQL standard does not define the concepts of the cluster.

## For More Information

Refer to the followings.

- ALTER TABLE name REBALANCE
- ALTER TABLE name REBALANCE EXCLUDE CLUSTER GROUP cluster\_group\_list
- ALTER TABLE name MOVE SHARD
- ALTER TABLE name MERGE SHARDS

## 18.66 ALTER TABLE name STORAGE

### Function

It alters physical attributes of a table.

### Syntax

```

<alter table physical attribute statement> ::=
    ALTER TABLE table_name
        [ <physical attribute clause> ]
        | [ STORAGE ( <segment attr clause> [...] ) ]
        ;
<physical attribute clause> ::=
    PCTFREE integer
    | PCTUSED integer
    | INITRANS integer
    | MAXTRANS integer
<segment attr clause> ::=
    NEXT <size_clause>
    | MINSIZE <size_clause>
    | MAXSIZE <size_clause>
<size clause> ::=
    integer [ K | M | G | T ]
  
```

### Invocation and Access Rules

One of the following privileges is required to perform <alter table physical attribute statement>.

- (ALTER or CONTROL TABLE) ON TABLE for that table
- (ALTER TABLE or CONTROL SCHEMA) ON SCHEMA for the schema to which the table belongs
- ALTER ANY TABLE ON DATABASE

## Syntax Rules and Parameters

### table\_name

It is the table name to be altered.

It can define the schema to which the table belongs, such as schema\_name.table\_name. If schema\_name is omitted, the default schema name of the user performing the statement is used.

### ⟨physical attribute clause⟩

It alters the physical attribute of a page which configures the table.

It is not applied to the already allocated page, but is applied to the newly allocated page.

For more information, refer to ⟨table physical attribute clause⟩ of CREATE TABLE.

### ⟨segment attr clause⟩

It alters the physical attribute of the extent configuring the segment. It is not applied to the already allocated extent but is applied to the newly allocated extent.

- MAXSIZE integer
  - It alters the space size of the segment which can be allocated.
  - If the newly allocated space is smaller than the already allocated space, the MAXSIZE is altered to the currently allocated space size.

## Description

For more information, refer to the rules for each syntax.

## Example

The following is an example of changing the physical attribute of the table.

```
gSQL> ALTER TABLE t1 PCTFREE 10 PCTUSED 40 STORAGE ( NEXT 10M MAXSIZE 100M );  
Table altered.
```

## Compatibility

The SQL standard does not define the physical property of a table.

## For More Information

Refer to **ALTER TABLE**.

## 18.67 ALTER TABLESPACE

### Function

It alters the tablespace definition.

### Syntax

```
<alter tablespace statement> ::=  
    <rename tablespace statement>  
  | <backup tablespace statement>  
  | <on/offline tablespace statement>  
  | <add file statement>  
  | <drop file statement>  
  | <rename datafile statement>  
  ;
```

### Invocation and Access Rules

ALTER TABLESPACE privilege is required to perform <alter tablespace statement>.

### Syntax Rules and Parameters

#### <rename tablespace statement>

It renames the tablespace.

For more information, refer to **ALTER TABLESPACE name RENAME TO** statement.

#### <backup tablespace statement>

It backs up the tablespace.

For more information, refer to **ALTER TABLESPACE name BACKUP** statement.

## ⟨on-offline tablespace statement⟩

It changes all files in the tablespace to the online state or offline state.

For more information, refer to **ALTER TABLESPACE name [ONLINE|OFFLINE]** statement.

## ⟨add file statement⟩

It adds a file to the tablespace.

For more information, refer to **ALTER TABLESPACE name ADD [DATAFILE|MEMORY]** statement.

## ⟨drop file statement⟩

It drops a file from the tablespace.

For more information, refer to **ALTER TABLESPACE name DROP [DATAFILE|MEMORY]** statement.

## ⟨rename datafile statement⟩

It renames the datafile in the data tablespace.

For more information, refer to **ALTER TABLESPACE name RENAME DATAFILE** statement.

## Description

Unlike other Data Definition Language (DDL), **ALTER TABLESPACE** statement is not allowed to **ROLLBACK**, and its transaction is automatically committed after executing the statement.

## Example

Refer to the examples of each detailed statement.

## Compatibility

The SQL standard does not define the concepts of the tablespace.

## For More Information

Refer to the followings.

- CREATE TABLESPACE
- DROP TABLESPACE

## 18.68 ALTER TABLESPACE name ADD [DATAFILE|MEMORY]

### Function

It extends the space of the tablespace.

### Syntax

```

<add space statement> ::=
    ALTER TABLESPACE tablespace_name ADD <space specification>
        [AT <domain name>]
    ;
<space specification> ::=
    MEMORY <memory clause> [, ...]
    | DATAFILE <add datafile clause> [, ...]
<size clause> ::=
    integer [ K | M | G | T ]
<memory clause>
    'memory_name' { SIZE <size clause> }
<add datafile clause> ::=
    'filename'
        { SIZE <size clause> | REUSE | SIZE <size clause> REUSE }
        [ <autoextend clause> ]
<autoextend clause>
    AUTOEXTEND { ON [ <next size clause> ] [ <max size clause> ] | OFF }
<next size clause>
    NEXT <size clause>
<max size clause>
    MAXSIZE { <size clause> | UNLIMITED }

```



## Invocation and Access Rules

ALTER TABLESPACE ON DATABASE privilege is required to perform <add space statement>.

## Syntax Rules and Parameters

### tablespace\_name

It is the tablespace name to be altered.

### <file specification>

The following syntax should be used according to the tablespace type.

- Memory data tablespace
  - DATAFILE <add datafile clause>
- Memory temporary tablespace
  - MEMORY <memory clause>

### <add datafile clause>

It defines the memory datafile to be added.

- 'filename'
  - It is the file name to store and manage the data.
  - It is the space to store the checkpoint image for the memory data.
  - The filename can be either the new file or existing file.
  - The length of filename should be shorter than 1024 bytes.
- SIZE <size clause>
  - For the new file, the initial size is specified by using SIZE clause.
  - An error occurs if the file exists.
  - The file size can be specified from 1M to 30G.
- REUSE
  - If the file exists, it uses REUSE clause.
  - If the file does not exist, a new file is created.
  - The size of newly created file
    - For the data tablespace, it is determined by MEMORY\_DATA\_TABLESPACE\_SIZE property.

- For the temporary table space, it is determined by MEMORY\_TEMP\_TABLESPACE\_SIZE property.
- SIZE <size clause> REUSE
  - If both of SIZE clause and REUSE clause are specified, it is operated as follows based on the presence of the filename.
    - For the new filename, the initial file size is specified by using SIZE clause.
    - For the existing filename, it is adjusted to the SIZE clause value by using the existing file.

## <memory clause>

- <size clause>
  - It defines the memory to be added.

For more information, refer to <memory clause> of CREATE MEMORY TEMPORARY TABLESPACE statement.

## <autoextend clause>

It sets the automatic extending property when adding the data file of the disk tablespace. Set the automatic extending property to *ON* or *OFF*. If it is set to *ON*, then it can define the size of the automatic extending and the maximum size of the data file.

## <next size clause>

It defines the space size to be extended when there is not any space available in the current data file in use.

## <max size clause>

It defines the maximum size of the data file which can be extended.

## <domain name>

It is a name of a member or a group for which the statement is performed. If it is omitted, it is performed for all groups.

## Description

For more information, refer to the rules for each syntax.

## Example

The following is an example of adding datafile to the tablespace.

```
gSQL> ALTER TABLESPACE space1 ADD DATAFILE 'test_file_a2.dbf' SIZE 10M REUSE;  
Tablespace altered.
```

## Compatibility

The SQL standard does not define the concepts of the tablespace.

## For More Information

Refer to the followings.

- CREATE MEMORY DATA TABLESPACE
- CREATE MEMORY TEMPORARY TABLESPACE
- ALTER TABLESPACE

## 18.69 ALTER TABLESPACE name BACKUP

### Function

It switches the tablespace to backup enabled state and backup disabled state to perform backup.

### Syntax

```

<backup tablespace statement> ::=
    <tablespace begin backup statement>
  | <tablespace end backup statement>
  | <tablespace incremental backup statement>
  ;

<tablespace begin backup statement> ::=
    ALTER TABLESPACE tablespace_name BEGIN BACKUP [AT <domain_name>]
  ;

<tablespace end backup statement> ::=
    ALTER TABLESPACE tablespace_name END BACKUP [AT <domain_name>]
  ;

<tablespace incremental backup statement> ::=
    ALTER TABLESPACE tablespace_name
      BACKUP INCREMENTAL <incremental backup option> [AT <domain_name>]  ;

<incremental backup option> ::=
    LEVEL integer [ CUMULATIVE | DIFFERENTIAL ]
  
```

### Invocation and Access Rules

ALTER TABLESPACE ON DATABASE privilege is required to perform <backup space statement>.

### Syntax Rules and Parameters

## ⟨tablespace begin backup statement⟩

It sets the tablespace to the backup enabled state.

- The tablespace being used is set to the backup enabled state.
- The backup state of the tablespace such as OFFLINE/ temporary can not be switched.

## tablespace\_name

It is the tablespace name whose backup state is to be switched.

## ⟨tablespace end backup statement⟩

It sets the tablespace to the backup disabled state.

## ⟨tablespace incremental backup statement⟩

It performs the incremental backup of the tablespace.

The database is in OPEN phase and it should be operated in ARCHIVELOG mode.

## ⟨incremental backup option⟩

- An 'Integer' can be specified from 0 to 4.
- 'LEVEL 0' can not specify CUMULATIVE or DIFFERENTIAL.
- CUMULATIVE | DIFFERENTIAL
  - CUMULATIVE
    - If 'integer' is n, it backs up all pages which are altered after the most recent backups of LEVEL 0 ~ LEVEL n-1.
  - DIFFERENTIAL
    - If 'integer' is n, it backs up all pages which are altered after the most recent backups of LEVEL 0 ~ LEVEL n.
  - If it is omitted, DIFFERENTIAL is specified by default.

## ⟨domain name⟩

It is a name of a member or a group for which the statement is performed.

If it is omitted, it is performed for all groups.

## Description

It backs up the datafiles which are created in the tablespace. A full backup of the tablespace begins with `BEGIN BACKUP`, and copies the datafiles by OS file copy and ends with `END BACKUP`. The incremental backup file is created in the path set by `BACKUP_DIR` 1 property using a single statement.

## Examples

The following is an example of setting the full backup state to 'ACTIVE' for the tablespace `DICTIONARY_TBS`.

```
ALTER TABLESPACE DICTIONARY_TBS BEGIN BACKUP;
```

The following is an example of setting the full backup state to 'INACTIVE' for the tablespace `DICTIONARY_TBS`.

```
ALTER TABLESPACE DICTIONARY_TBS END BACKUP;
```

The following is an example of generating the LEVEL 0 incremental backup of the tablespace `DICTIONARY_TBS`.

```
ALTER TABLESPACE DICTIONARY_TBS BACKUP INCREMENTAL LEVEL 0;
```

## Compatibility

The SQL standard does not define the concepts of the tablespace.

## For More Information

Refer to the followings.

- `ALTER TABLESPACE`
- `ALTER TABLESPACE name [ONLINE|OFFLINE]`

## 18.70 ALTER TABLESPACE name DROP [DATAFILE|MEMORY]

### Function

It reduces the space of the tablespace.

### Syntax

```
<drop space statement> ::=  
    ALTER TABLESPACE tablespace_name DROP <file specification>  
    [ AT <domain name> ]  
    ;  
<file specification> ::=  
    DATAFILE 'filename'  
    | MEMORY 'memory_name'
```

### Invocation and Access Rules

ALTER TABLESPACE ON DATABASE privilege is required to perform <drop space statement>.

### Syntax Rules and Parameters

#### tablespace\_name

It is the tablespace name to be altered.

#### <file specification>

The following syntax should be used according to the tablespace type.

- Memory data tablespace
  - DATAFILE 'filename'

- Memory temporary tablespace
  - MEMORY 'memory\_name'



The file of OFFLINE tablespace can not be dropped.  
The first file of the tablespace can not be dropped.  
The data file which has been used once can not be dropped.

## <domain name>

It is a name of a member or a group for which the statement is performed.  
If it is omitted, it is performed for all groups.

## Description

For more information, refer to the rules for each syntax.

## Example

The following is an example of dropping the file from the tablespace.

```
gSQL> ALTER TABLESPACE space1 DROP DATAFILE 'test_file_f2.dbf';  
Tablespace altered.
```

## Compatibility

The SQL standard does not define the concepts of the tablespace.

## For More Information

Refer to the followings.

- ALTER TABLESPACE
- ALTER TABLESPACE name ADD [DATAFILE|MEMORY]
- ALTER TABLESPACE name RENAME DATAFILE



## 18.71 ALTER TABLESPACE name [ONLINE|OFFLINE ]

### Function

It alters the tablespace status.

### Syntax

```
<on/off tablespace statement> ::=  
    ALTER TABLESPACE tablespace_name { ONLINE | OFFLINE [ NORMAL | IMMEDIATE ] }  
    [ AT <domain name> ]  
    ;
```

### Invocation and Access Rules

ALTER TABLESPACE ON DATABASE privilege is required to perform <on/off tablespace statement>.

### Syntax Rules and Parameters

#### ONLINE

It alters the tablespace status in OFFLINE state to ONLINE state.

#### OFFLINE NORMAL

It alters the tablespace status in ONLINE state to OFFLINE state.

The media recovery is not required in ONLINE state because the tablespace which was altered to OFFLINE state is in consistent state.



OFFLINE NORMAL is not allowed in MOUNT phase.  
(However, if the previous instance is terminated by \SHUTDOWN NORMAL, OFFLINE NORMAL is allowed.)

## OFFLINE IMMEDIATE

It alters the tablespace status in ONLINE state to OFFLINE state.

The media recovery is required in ONLINE state because the tablespace which was altered to OFFLINE state is in inconsistent state.



The SYSTEM tablespace can not be altered to OFFLINE state.  
OFFLINE IMMEDIATE requires the media recovery, so it can be performed only in ARCHIVELOG mode.

## <domain name>

It is a name of a member or a group for which the statement is performed.

If it is omitted, it is performed for all groups.

## Description

For more information, refer to the rules for each syntax.

## Examples

The following is an example of setting the tablespace to OFFLINE.

```
gSQL> ALTER TABLESPACE space1 OFFLINE;
Tablespace altered.
```

The following is an example of that OFFLINE NORMAL for the tablespace fails in MOUNT phase.

```
gSQL> ALTER TABLESPACE space1 OFFLINE;
ERR-42000(16290): OFFLINE NORMAL is only allowed if the database is in OPEN phase :
```

```
ALTER TABLESPACE space1 OFFLINE
```

```
*
```

```
ERROR at line 1:
```

```
gSQL> ALTER TABLESPACE space1 OFFLINE NORMAL;
```

```
ERR-42000(16290): OFFLINE NORMAL is only allowed if the database is in OPEN phase :
```

```
ALTER TABLESPACE space1 OFFLINE NORMAL
```

```
*
```

```
ERROR at line 1:
```

## Compatibility

The SQL standard does not define the concepts of the tablespace.

## For More Information

Refer to the followings.

- ALTER TABLESPACE
- ALTER TABLESPACE name BACKUP

## 18.72 ALTER TABLESPACE name RENAME DATAFILE

### LE

### Function

It renames the datafiles which configures the tablespace.

### Syntax

```
<rename datafile statement> ::=  
    ALTER TABLESPACE tablespace_name RENAME DATAFILE <filename_list> TO <filename_list>  
    ;  
    <filename_list> ::=  
        'filename' [, ...]
```

### Invocation and Access Rules

ALTER TABLESPACE ON DATABASE privilege is required to perform <rename datafile statement>.



ONLINE tablespace file can not be altered when it is in TDS mode and the database is in OPEN phase. (Except for the temporary memory tablespace.)  
The file should exist even after the alteration.

### Syntax Rules and Parameters

#### tablespace\_name

It is the tablespace name to be altered.

## 'filename'

The memory temporary tablespace is 'memory\_name' and the other kinds of tablespace is 'filename'.

## <domain name>

It is a name of a member or a group for which the statement is performed.

If it is omitted, it is performed for all groups.

## Description

The tablespace status determines whether the operation can be performed.

- OFFLINE: It can be performed in MOUNT or OPEN phase.
- ONLINE: It can be performed only in MOUNT phase.

## Example

The following is an example of renaming 'test.dbf' to 'test1.dbf'.

```
gSQL> ALTER TABLESPACE TEST_TBS RENAME DATAFILE 'test.dbf' TO 'test1.dbf';  
Tablespace altered.
```

## Compatibility

The SQL standard does not define the concepts of the tablespace.

## For More Information

Refer to the followings.

- ALTER TABLESPACE
- ALTER TABLESPACE name ADD [DATAFILE|MEMORY]
- ALTER TABLESPACE name DROP [DATAFILE|MEMORY]

## 18.73 ALTER TABLESPACE name RENAME TO

### Function

It renames the tablespace.

### Syntax

```
<rename tablespace statement> ::=  
    ALTER TABLESPACE tablespace_name RENAME TO <new_tablespace_name>  
    ;
```

### Invocation and Access Rules

ALTER TABLESPACE ON DATABASE privilege required to perform <rename space statement>.

### Syntax Rules and Parameters

#### tablespace\_name

It is a name of the old tablespace.

- The built-in tablespace can not be renamed.
- The OFFLINE tablespace can not be renamed.

#### new\_tablespace\_name

It is a name of the new tablespace.

## Description

Even when the tablespace is renamed, the table or index which was already created in the existing tablespace does not need to be renamed.

## Example

The following is an example of renaming the tablespace.

```
gSQL> ALTER TABLESPACE space1 RENAME TO space2;  
Tablespace altered.
```

## Compatibility

The SQL standard does not define the concepts of the tablespace.

## For More Information

Refer to **ALTER TABLESPACE**.

## 18.74 ALTER USER

### Function

It alters the user definition of the database.

### Syntax

```

<alter user statement> ::=
    ALTER USER user_identifier <alter user action>
    | ALTER USER PUBLIC <alter schema path>
    ;

<alter user action> ::=
    <alter password>
    | <alter profile>
    | <password expire>
    | <account lock>
    | <alter default tablespace>
    | <alter temporary tablespace>
    | <alter schema path>

<alter password> ::=
    IDENTIFIED BY new_password [ REPLACE old_password ]

<alter profile> ::=
    PROFILE { profile_name | DEFAULT | NULL }

<password expire> ::=
    PASSWORD EXPIRE

<account lock> ::=
    ACCOUNT { LOCK | UNLOCK }

<alter default tablespace> ::=
    DEFAULT TABLESPACE tablespace_name

<alter temporary tablespace> ::=
    TEMPORARY TABLESPACE tablespace_name

<alter schema path> ::=
    SCHEMA PATH ( { schema_name | CURRENT PATH } [, ...] )

```



## Invocation and Access Rules

ALTER USER ON DATABASE privilege is required to perform <alter user statement>.

However, <alter password> can be performed without any privilege, when the user and the user identifier are identical.

## Syntax Rules and Parameters

### user\_identifier

It is the username to be altered.

### <alter password>

It alters the user's password.

- IDENTIFIED BY new\_password
  - The new password is encrypted and stored.
  - The length of the password should be shorter than 128 byte.
  - The password is case sensitive.
- REPLACE old\_password
  - It can be omitted when ALTER USER ON DATABASE privilege is given.
  - It can not be omitted when ALTER USER ON DATABASE privilege is not given.
    - The user and the user identifier should be identical.

### <alter profile>

It alters the profile for the password management policy.

- PROFILE profile\_name
  - It allocates profile\_name which is created by a user.
- PROFILE DEFAULT
  - It allocates "DEFAULT" which is the default profile.
- PROFILE NULL
  - It does not allocate the profile.

## ⟨password expire⟩

It expires the user's password.

## ⟨account lock⟩

- ACCOUNT LOCK
  - It locks the user account.
- ACCOUNT UNLOCK
  - It unlocks the user account.

## ⟨alter default tablespace⟩

It alters the user's default tablespace.

The tablespace\_name should be a data tablespace.

## ⟨alter temporary tablespace⟩

It alters the user's temporary tablespace.

The tablespace\_name should be a temporary tablespace.

## ⟨alter index tablespace⟩

It alters an index tablespace of the user.

- It specifies INDEX TABLESPACE tablespace\_name.
  - If the data tablespace is specified, then it becomes a LOGGING index.
  - If the temporary tablespace is specified, then it becomes a NOLOGGING index.
- INDEX TABLESPACE NULL
  - It does not specify an index tablespace.

## ⟨alter schema path⟩

It alters the user's schema access path.

If the schema is not specified in user's SQL statement, the schema access path is determined in the schema order for the naming resolution of the object.

If the schema name is as same as another schema which is previously listed, it is not applied.

The following is an example of objects existing in a schema when performing *ALTER USER u1 SCHEMA PATH ( u1, s2, public );* statement.

Schema name	u1	s2	public
-	t1	-	t1
-	-	t2	-
-	-	-	t3

The object name whose schema name is not specified when the user u1 executes the schema is interpreted by the SCHEMA PATH as follows.

- CREATE statement
  - CREATE TABLE t1 ( c1 INTEGER );
    - Error: CREATE TABLE u1.t1 ( c1 INTEGER );
  - CREATE TABLE t2 ( c1 INTEGER );
    - Execution: CREATE TABLE u1.t2 ( c1 INTEGER );
- SELECT statement
  - SELECT \* FROM t1;
    - Execution: SELECT \* FROM u1.t1;
  - SELECT \* FROM t2;
    - Execution: SELECT \* FROM s2.t2;
  - SELECT \* FROM t3;
    - Execution: SELECT \* FROM public.t3;

## CURRENT PATH

It is the current user's schema path.

A new schema path can be added using CURRENT PATH maintaining the existing schema path as follows.

- The u1's current schema path
  - (u1, public)
- The statement execution
  - ALTER USER u1 SCHEMA PATH ( s1, CURRENT PATH, s2 );
- The u1's schema path is altered as follows.
  - (s1, u1, public, s2)

## ALTER USER PUBLIC <alter schema path>

It alters the schema path of PUBLIC account.

The schema path of PUBLIC account is included in every user's the schema path.

The initial schema path which is allocated to PUBLIC account is as follows.

- DICTIONARY\_SCHEMA
- INFORMATION\_SCHEMA
- DEFINITION\_SCHEMA
- PERFORMANCE\_VIEW\_SCHEMA
- FIXED\_TABLE\_SCHEMA

## Description

For more information, refer to the rules for each syntax.

## Examples

The following is an example of altering the user's password.

```
gSQL> ALTER USER u1 IDENTIFIED BY new_password;  
User altered.
```

The following is an example of allocating the profile to the user.

```
gSQL> ALTER USER u1 PROFILE prof1;  
User altered.  
gSQL> COMMIT;  
Commit complete.
```

The following is an example of dropping the user's profile.

```
gSQL> ALTER USER u1 PROFILE NULL;  
User altered.  
gSQL> COMMIT;  
Commit complete.
```

The following is an example of expiring the user's password.

```
gSQL> ALTER USER u1 PASSWORD EXPIRE;  
User altered.  
gSQL> COMMIT;  
Commit complete.
```

The following is an example of unlocking the user's account.

```
gSQL> ALTER USER u1 ACCOUNT UNLOCK;  
User altered.  
gSQL> COMMIT;  
Commit complete.
```

The following is an example of altering the user's DEFAULT TABLESPACE.

```
gSQL> ALTER USER u1 DEFAULT TABLESPACE mem_data_tbs;  
User altered.
```

The following is an example of altering the user's TEMPORARY TABLESPACE.

```
gSQL> ALTER USER u1 TEMPORARY TABLESPACE mem_temp_tbs;  
User altered.
```

The following is an example of altering the user's INDEX TABLESPACE.

```
gSQL> ALTER USER u1 INDEX TABLESPACE mem_temp_tbs;  
User altered.
```

The following is an example of altering the user's schema path.

```
gSQL> ALTER USER u1 SCHEMA PATH ( s1, CURRENT PATH );  
User altered.
```

## Compatibility

SQL standard covers the concepts of a user, but it does not define the SQL statements associated with creating, altering, dropping a user.

## For More Information

Refer to the followings.

- `CREATE USER`
- `DROP USER`

## 18.75 ALTER VIEW

### Function

It alters the view definition.

### Syntax

```
<alter view statement> ::=  
    ALTER VIEW view_name <alter view action>  
    ;  
<alter view action> ::=  
    COMPILE
```

### Invocation and Access Rules

One of the following privileges is required to perform <alter view statement>.

- (ALTER or CONTROL TABLE) ON TABLE for the view
- (ALTER TABLE or CONTROL SCHEMA) ON SCHEMA for the schema to which the view belongs
- ALTER ANY TABLE ON DATABASE

### Syntax Rules and Parameters

#### view\_name

It is the view name to be altered.

It can define the schema to which the view belongs, such as schema\_name.view\_name. If schema\_name is omitted, the default schema name of the user performing the statement is used.

## COMPILE

It compiles the view again.

COMMENT which is given to the view column is initialized.

## Description

When the table or the view which is referenced by the view is altered or dropped, then it affects that view.

This information can be retrieved from INFORMATION\_SCHEMA.VIEWS.

- IS\_COMPILED column
  - TRUE: The view was successfully created.
  - FALSE: The view was created with FORCE option when an error exists.
- IS\_AFFECTED column
  - TRUE: The table and the view which was referenced by the view was altered.
  - FALSE: After creation and compilation of a view, the table and the view which was referenced by the view was not altered.

## Example

The following is an example of compiling the view which is affected by the table change referenced by that view.

```
gSQL> SELECT TABLE_NAME, IS_AFFECTED
        FROM INFORMATION_SCHEMA.VIEWS
        WHERE TABLE_SCHEMA = 'PUBLIC'
          AND TABLE_NAME = 'V1';
TABLE_NAME IS_AFFECTED
-----
V1          TRUE
1 row selected.
gSQL> ALTER VIEW v1 COMPILE;
View altered.
COMMIT;
Commit complete.
gSQL> SELECT TABLE_NAME, IS_AFFECTED
```



```
FROM INFORMATION_SCHEMA.VIEWS
WHERE TABLE_SCHEMA = 'PUBLIC'
AND TABLE_NAME = 'V1';
TABLE_NAME IS_AFFECTED
-----
V1          FALSE
1 row selected.
```

## Compatibility

The SQL standard does not define <alter view statement>.

## For More Information

Refer to the followings.

- [CREATE VIEW](#)
- [DROP VIEW](#)

## 18.76 ANALYZE SYSTEM

### Function

It controls the statistics information of the system.

### Syntax

```
<analyze system statement> ::=  
    ANALYZE SYSTEM [ <analyze action> ]  
    ;  
<analyze action> ::=  
    COMPUTE STATISTICS  
    | DELETE STATISTICS
```

### Invocation and Access Rules

ANALYZE ANY ON DATABASE privilege is required to perform <analyze system statement>.

### Syntax Rules and Parameters

#### <analyze action>

When it is omitted, the default value is COMPUTE STATISTICS.

#### COMPUTE STATISTICS

It builds the following statistics information related to the system.

- CPU\_OPS (Operations Per Second)
  - It is the number of operations of which the CPU can process per second.
- NETWORK\_IOPS (I/O operations Per Second)
  - It is valid for the cluster.

- It is the number of the network I/O which can be processed per second.

## DELETE STATISTICS

It deletes the statistics information of the system.

## Description

The built statistics information of the system is used to calculate the cost of optimization for the query process.

## Examples

The following is an example of building the statistics information of the system by using the <analyze system statement> statement.

```
gSQL> ANALYZE SYSTEM COMPUTE STATISTICS;  
analyzed.
```

The following is an example of retrieving the built statistics information of the system.

```
gSQL>  
SELECT * FROM DBA_STAT_SYSTEM;  
CPU_OPS NETWORK_IOPS NETWORK_BUFSIZE LAST_ANALYZED  
-----  
53000412          2914          65536 2017-03-30 16:49:42.200000  
1 row selected.
```

## Compatibility

The SQL standard does not define the concepts of the statistics information.

## For More Information

Refer to **ANALYZE TABLE**.

## 18.77 ANALYZE TABLE

### Function

It controls the statistics information of the table.

### Syntax

```

<analyze table statement> ::=
    ANALYZE TABLE table_name
    [ <parallel clause> ]
    [ <analyze action> ]
    ;
<parallel clause> ::=
    NOPARALLEL
    | PARALLEL [thread_count]
<analyze action> ::=
    COMPUTE STATISTICS [ <for_clause> ]
    | ESTIMATE STATISTICS <sample_clause> [ <for_clause> ]
    | DELETE STATISTICS
<sample_clause>
    SAMPLE row_count ROWS
    | SAMPLE percentage PERCENT
<for_clause>
    FOR ALL COLUMNS
    | FOR ALL INDEXED COLUMNS
    | FOR COLUMNS column_name [, ...]
    | FOR ALL INDEXES
    | FOR INDEXES index_name [, ...]
  
```

### Invocation and Access Rules

ANALYZE ANY ON DATABASE privilege is required to perform <analyze table statement>.

## Syntax Rules and Parameters

### table\_name

It is the table name.

It can define the schema to which the table belongs, such as schema\_name.table\_name. If schema\_name is omitted, the default schema name of the user performing the statement is used.

### <parallel clause>

It specifies the number of threads to be used in a analyzing process.

If it is not specified, the default value is PARALLEL.

- NOPARALLEL
  - It does not analyze in parallel.
- PARALLEL [thread\_count]
  - It analyzes in parallel.
  - The minimum value of the thread\_count is 0, and the maximum value is 64.
  - If the thread\_count value is 0 or it is omitted, then it is determined by the number of CPUs in the system.

### <analyze action>

When it is omitted, the default value is COMPUTE STATISTICS.

## COMPUTE STATISTICS

It builds the following statistics information related to the table through the all inspection.

- The table statistics information
  - Row count
- The statistics information of each column
  - The number of different values
  - The number of NULL values
  - The average length of the value
  - The minimum value
  - The maximum value
- The statistics information of an index
  - The number of different keys

The statistics information which is built according to the data type of the column is as follows.

**Table 18-20** Statistics information built according to the data type

Data type	NUM_DISTINCT	NUM_NULLS	AVG_LENGTH	MIN/MAX
BOOLEAN	O	O	O	X
NATIVE_SMALLINT	O	O	O	O
NATIVE_INTEGER	O	O	O	O
NATIVE_BIGINT	O	O	O	O
NATIVE_REAL	O	O	O	O
NATIVE_DOUBLE	O	O	O	O
NUMBER	O	O	O	O
NUMERIC	O	O	O	O
FLOAT	O	O	O	O
CHAR(n)	O	O	O	It is built when it is 64 bytes or smaller.
VARCHAR(n)	O	O	O	It is built when it is 64 bytes or smaller.
LONG VARCHAR	X	X	X	X
BINARY	O	O	O	X
VARBINARY	O	O	O	X
LONG VARBINARY	X	X	X	X
DATE	O	O	O	O
TIME	O	O	O	O
TIMESTAMP	O	O	O	O
INTERVAL	O	O	O	O
ROWID	O	O	O	X

## ESTIMATE STATISTICS <sample\_clause>

It builds the statistics information of the column and the index by using as many samples as the specified <sample\_clause>.

- SAMPLE row\_count ROWS
  - It uses as many samples as the specified number of rows.
  - row\_count is a positive integer bigger than 0.
- SAMPLE percentage PERCENT
  - It uses as many samples as the specified ratio.
  - The percentage is a positive integer in the range between 1 and 99.

If the number of the sampling rows are smaller than the value of **MIN\_SAMPLE\_ROW\_COUNT** property, then it follows the property value.

## <for\_clause>

If it is omitted, it builds the statistics information of all possible columns and indexes.

### FOR ALL COLUMNS

It builds the statistics information of all possible columns.

It does not build the statistics information of an index.

### FOR ALL INDEXED COLUMNS

It builds the statistics information of all columns included in an index.

It does not build the statistics information of other columns.

It does not build the statistics information of an index.

### FOR COLUMNS *column\_name* [, ...]

It builds the statistics information of the listed columns.

It does not build the statistics information of unlisted columns.

It does not build the statistics information of an index.

### FOR ALL INDEXES

It builds the statistics information of all indexes.

It does not build the statistics information of columns.

### FOR INDEXES *index\_name* [, ...]

It builds the statistics information of the listed indexes.

It does not build the statistics information of unlisted indexes.

It does not build the statistics information of a column.

### DELETE STATISTICS

It deletes the statistics information of the table.



## Description

The statistics information of the table affects the query optimization, so it is very important information.

The time to build the statistics information is increased in proportion to the data volumes in a table. Therefore, when the data volume is big, then it is recommended to build the statistics information by using the sampling or to build only the statistics of major information which affects the query.

- The following is an example of building the statistics information by using the sampling.

```
ANALYZE TABLE lineitem ESTIMATE STATISTICS SAMPLE 10 PERCENT;
```

- The following is an example of building the statistics information only of major columns and the index.

```
ANALYZE TABLE lineitem COMPUTE STATISTICS FOR ALL INDEXED COLUMNS;
ANALYZE TABLE lineitem COMPUTE STATISTICS FOR ALL INDEXES;
```

## Examples

The following is an example of building the statistics information through the all inspection.

```
gSQL> ANALYZE TABLE orders;
Table analyzed.
```

The following is an example of retrieving the built statistics information of the table.

```
gSQL>
SELECT
    TABLE_NAME
    , NUM_ROWS
FROM
    DICTIONARY_SCHEMA.USER_TABLES
WHERE
    TABLE_SCHEMA = 'PUBLIC'
    AND TABLE_NAME = 'ORDERS'
;
TABLE_NAME NUM_ROWS
-----
ORDERS      1500000
```

1 row selected.

gSQL>

SELECT

```

    TABLE_NAME
  , COLUMN_NAME
  , NUM_DISTINCT
  , NUM_NULLS
  , LOW_VALUE
  , HIGH_VALUE

```

FROM

```

    DICTIONARY_SCHEMA.USER_TAB_COLUMNS

```

WHERE

```

    TABLE_SCHEMA = 'PUBLIC'
  AND TABLE_NAME = 'ORDERS'

```

;

TABLE_NAME	COLUMN_NAME	NUM_DISTINCT	NUM_NULLS	LOW_VALUE	HIGH_VALUE
ORDERS	O_ORDERKEY	1500000	0	1	6000000
ORDERS	O_CUSTKEY	99996	0	1	149999
ORDERS	O_ORDERSTATUS	3	0	F	P
ORDERS	O_TOTALPRICE	1464556	0	857.71	555285.16
ORDERS	O_ORDERDATE	2406	0	1992-01-01 00:00:00	1998-08-02 00:00:00
ORDERS	O_ORDERPRIORITY	5	0	1-URGENT	5-LOW
ORDERS	O_CLERK	1000	0	Clerk#000000001	Clerk#000001000
ORDERS	O_SHIPPRIORITY	1	0	0	0
ORDERS	O_COMMENT	1482071	0	null	null

9 rows selected.

gSQL>

SELECT

```

    TABLE_NAME
  , INDEX_NAME
  , DISTINCT_KEYS

```

FROM

```

    DICTIONARY_SCHEMA.USER_INDEXES

```

WHERE

```

    TABLE_SCHEMA = 'PUBLIC'
  AND TABLE_NAME = 'ORDERS'

```

;

TABLE_NAME	INDEX_NAME	DISTINCT_KEYS
ORDERS	ORDERS_PK_INDEX	1500000

ORDERS      ORDERS\_CUSTKEY\_FK      99996  
2 rows selected.

## Compatibility

The SQL standard does not define the concepts of the statistics information.

## For More Information

Refer to **ANALYZE SYSTEM**.

## 18.78 AUDIT POLICY

### Function

It activates the audit policy.

### Syntax

```
<audit policy statement> ::=  
    AUDIT POLICY policy_name  
    [ <specified_user_option> ]  
    [ <specified_success_option> ]  
    ;  
<specified_user_option> ::=  
    BY user_name [, ...]  
    | EXCEPT user_name [, ...]  
<specified_success_option> ::=  
    WHENEVER SUCCESSFUL  
    | WHENEVER NOT SUCCESSFUL
```

### Invocation and Access Rules

AUDIT SYSTEM ON DATABASE privilege is required to perform <audit policy statement>.

### Syntax Rules and Parameters

#### policy\_name

It is the name of the audit policy object to be activated.

The activated audit policy does not effect on the existing session, and it effects only on the newly created session.

## <specified\_user\_option>

It specifies the user to be audited.

If omitted, all users are audited.

BY clause and EXCEPT clause can not be used together for the same audit policy.

- BY user\_list: If the user to be audited is specified, then use BY clause.
- EXCEPT user\_list: If other users excluding a specific user is to be audited, use EXCEPT clause.

## <specified\_success\_option>

- WHENEVER SUCCESSFUL
  - If an action succeeds, then the audit record is created.
- WHENEVER NOT SUCCESSFUL
  - If an action fails, then the audit record is created.
- If omitted, both when an action succeeds and fails, the audit record is created.

## Description

Activating the audit policy does not affect the existing session, but it starts to audit the newly created session.

## Retrieving Audit Record

The audit record is created when it corresponds to the audit policy, and it can be retrieved through DICTIONARY\_SCHEMA.AUDIT\_TRAIL view as follows.

```
SELECT logon_user
       , event_timestamp
       , action_name
       , object_name
       , sql_text
FROM audit_trail
WHERE policy_name = 'P1'
;
```

SELECT privilege should be given to an ordinary user to retrieve AUDIT\_TRAIL.

```
GRANT SELECT ON DICTIONARY_SCHEMA.AUDITrail TO user_name;
```

## Retrieving Audit Policy Information

The information about the audit policy object can be retrieved through `DICTIONARY_SCHEMA.AUDIT_POLICY_OPTIONS` view.

```
SELECT policy_name
       , audit_option
       , object_schema
       , object_name
FROM audit_policy_options
;
```

The information about whether the audit policy object is activated can be retrieved through `DICTIONARY_SCHEMA.AUDIT_POLICY_ENABLED` view.

```
SELECT policy_name
       , enabled_opt
       , user_name
       , when_success
       , when_failure
FROM audit_policy_enabled
;
```

## Cautions When Using BY and EXCEPT Clauses

Activate the users group if multiple `AUDIT POLICY BY` clauses are used for the same audit policy. In other words, the following two examples have the same meaning.

- Example 1: It activates the p1 audit policy for u1 and u2.

```
AUDIT POLICY p1 BY u1;
AUDIT POLICY p1 BY u2;
```

- Example 2: It activates the p1 audit policy for u1 and u2.

```
AUDIT POLICY p1 BY u1, u2;
```

If multiple `AUDIT POLICY EXCEPT` clauses are used for the same audit policy, only the last `AUDIT POLICY` clause is valid.

In other words, the following two examples have different meanings.

- Example 1: Only the last clause is valid, and activates the p1 audit policy excluding u2.

```
AUDIT POLICY p1 EXCEPT u1;
AUDIT POLICY p1 EXCEPT u2;
```

- Example 2: It activates the p1 audit policy excluding u1 and u2.

```
AUDIT POLICY p1 EXCEPT u1, u2;
```

BY and EXCEPT can not be used together for the same policy.

- If the audit policy is activated with BY clause, then only BY clause can be used afterwards.

```
AUDIT POLICY p1 BY u1;
```

- Error

```
AUDIT POLICY p1 EXCEPT u2;
```

- If the audit policy is activated with EXCEPT clause, then only EXCEPT clause can be used afterwards.

```
AUDIT POLICY p1 EXCEPT u1;
```

- Error: It corresponds to *by all users*.

```
AUDIT POLICY p1;
```

If a user wants to convert the audit policy activated with BY to EXCEPT or to convert the audit policy activated with EXCEPT to BY, the activated audit policy should be deactivated first, then it can be converted.

Deactivate the audit policy with NOAUDIT POLICY statement as follows.

- AUDIT POLICY p1 BY u1, u2;
  - NOAUDIT POLICY p1 BY u1, u2;
- AUDIT POLICY p1;
  - NOAUDIT POLICY p1;
- AUDIT POLICY p1 EXCEPT u1, u2;
  - NOAUDIT POLICY p1;
  - NOAUDIT POLICY statement does not have an EXCEPT option.

WHENEVER clause which is used together with BY clause is accumulated.

The following two examples have the same meaning.

- Example 1: It creates the audit record regardless of success/ failure.

```
AUDIT POLICY p1 BY u1 WHENEVER SUCCESSFUL;
AUDIT POLICY p1 BY u1 WHENEVER NOT SUCCESSFUL;
```

- Example 2: It creates the audit record regardless of success/ failure.

```
AUDIT POLICY p1 BY u1;
```

If WHENEVER clauses are used together with EXCEPT clause, only the last WHENEVER clause is valid.

The following two examples have different meanings.

- Example 1: It creates the audit record when it fails.

```
AUDIT POLICY p1 EXCEPT u1 WHENEVER SUCCESSFUL;
AUDIT POLICY p1 EXCEPT u1 WHENEVER NOT SUCCESSFUL;
```

- Example 2: It creates the audit record regardless of success/ failure.

```
AUDIT POLICY p1 EXCEPT u1;
```

## Examples

The following is an example of activating the audit policy for all users.

```
AUDIT POLICY table_pol;
```

The information about activation can be viewed through the following query.

```
SELECT policy_name
       , enabled_opt
       , user_name
FROM   audit_policy_enabled
WHERE  policy_name = 'TABLE_POL';
```

POLICY_NAME	ENABLED_OPT	USER_NAME
TABLE_POL	BY	ALL USERS

The following is an example of activating the audit policy by defining specific users.



```
AUDIT POLICY dml_pol BY u1, u2;
```

The following is an example of activating the audit policy by excluding a specific user.

```
AUDIT POLICY read_seq_pol EXCEPT sys;
```

The following is an example of auditing the failure of SQL statement by a specific user.

```
AUDIT POLICY delete_pol BY u1 WHENEVER NOT SUCCESSFUL;
```

## Compatibility

The SQL standard does not have the audit policy.

## For More Information

Refer to the followings.

- Managing audit policy object
  - **CREATE AUDIT POLICY**
  - **DROP AUDIT POLICY**
  - **ALTER AUDIT POLICY**
- Activating/ deactivating audit policy
  - **AUDIT POLICY**
  - **NOAUDIT POLICY**
- Viewing audit trail: **AUDIT\_TRAIL**
- Clearing audit trail: **ALTER DATABASE CLEAR AUDIT TRAIL**



**19.**

---

**SQL References (C~G)**

## 19.1 CLOSE cursor\_name

### Function

It closes a cursor.

### Syntax

```
<close statement> ::=  
    CLOSE cursor_name  
    ;
```

### Syntax Rules and Parameters

#### cursor\_name

The cursor should be open.

The cursor should be declared with **DECLARE cursor\_name** statement in the session.

### Description

The cursor is an object which exists in the session and it does not affect the cursor in a different session.

### Example

The following is an example of DECLARE, OPEN, FETCH, and CLOSE the cursor by using gsql (interactive SQL tool).

```
gSQL> DECLARE cur1 CURSOR FOR SELECT id, data FROM t1;  
Cursor declared.  
gSQL> OPEN cur1;  
Cursor is open.
```

```

gSQL> \var v_id  INTEGER
gSQL> \var v_data VARCHAR(128)
gSQL> FETCH cur1 INTO :v_id, :v_data;
V_ID V_DATA
-----
      1 data_1
1 row fetched.
gSQL> FETCH cur1 INTO :v_id, :v_data;
V_ID V_DATA
-----
      2 data_2
1 row fetched.
gSQL> FETCH cur1 INTO :v_id, :v_data;
no rows fetched.
gSQL> CLOSE cur1;
Cursor closed.

```

## Compatibility

Table 19-1 SQL standard compatibility

Feature ID	Description	Compatibility
B031	Basic dynamic SQL	O

## For More Information

Refer to the followings.

- DECLARE cursor\_name
- OPEN cursor\_name
- FETCH cursor\_name

## 19.2 COMMENT ON name IS

### Function

It stores the comments about the object in the dictionary.

### Syntax

```
<comment statement> ::=
    COMMENT ON <comment object> IS 'comment string'
    ;
<comment object> ::=
    CLUSTER GROUP group_name
    | CLUSTER MEMBER member_name
    | DATABASE
    | PROFILE profile_name
    | AUTHORIZATION user_name
    | TABLESPACE tablespace_name
    | SCHEMA schema_name
    | TABLE [schema_name].table_name
    | COLUMN [schema_name].table_name.column_name
    | INDEX [schema_name].index_name
    | SEQUENCE [schema_name].sequence_name
    | CONSTRAINT [schema_name].constraint_name
    | PROCEDURE [schema_name].procedure_name
```

### Invocation and Access Rules

The altering privileges on each object are required to perform <comment statement> as follows.

- CLUSTER GROUP
  - ALTER SYSTEM ON DATABASE
- CLUSTER MEMBER
  - ALTER SYSTEM ON DATABASE
- DATABASE

- ALTER DATABASE ON DATABASE
- PROFILE
  - ALTER PROFILE ON DATABASE
- AUDIT POLICY
  - AUDIT SYSTEM ON DATABASE
- AUTHORIZATION (user)
  - ALTER USER ON DATABASE
- AUTHORIZATION (role)
  - ALTER ROLE ON DATABASE
- TABLESPACE
  - ALTER TABLESPACE ON DATABASE
- SCHEMA: One of the following privileges is required.
  - The owner of the schema
  - CONTROL SCHEMA ON SCHEMA for the schema
  - ALTER SCHEMA ON DATABASE
- TABLE: One of the following privileges is required.
  - The owner of the table
  - CONTROL TABLE ON TABLE for the table
  - CONTROL SCHEMA ON SCHEMA for the schema to which the table belongs
  - ALTER ANY TABLE ON DATABASE
- COLUMN: One of the following privileges is required.
  - The owner of the table to which the column belongs
  - CONTROL TABLE ON TABLE for the table to which the column belongs
  - CONTROL SCHEMA ON SCHEMA for the schema of the table to which the column belongs
  - ALTER ANY TABLE ON DATABASE
- INDEX: One of the following privileges is required.
  - The owner of the index
  - CONTROL SCHEMA ON SCHEMA for the schema to which the index belongs
  - ALTER ANY INDEX ON DATABASE
- SEQUENCE
  - The owner of the sequence
  - CONTROL SCHEMA ON SCHEMA for the schema to which the sequence belongs
  - ALTER ANY SEQUENCE ON DATABASE
- CONSTRAINT
  - The owner of that constraint
  - CONTROL SCHEMA ON SCHEMA for the schema to which the constraint belongs
  - ALTER ANY TABLE ON DATABASE
- PROCEDURE
  - The owner of the stored procedure/function
  - CONTROL SCHEMA ON SCHEMA for the schema to which the stored procedure/function belong

- ALTER ANY PROCEDURE ON DATABASE

## Syntax Rules and Parameters

### <comment object>

It is an object in which the comments are to be stored. The comments for the following database objects are stored.

- Cluster object
  - CLUSTER GROUP
  - CLUSTER MEMBER
- Non-schema object
  - DATABASE
  - PROFILE
  - AUDIT POLICY
  - AUTHORIZATION (User or role)
  - TABLESPACE
  - SCHEMA
- Schema object
  - TABLE or VIEW
  - COLUMN
  - INDEX
  - SEQUENCE
  - CONSTRAINT
  - PROCEDURE or FUNCTION

If schema\_name for the schema object is not specified, the schema name is determined by **Schema Path** of the user performing the statement.

```
COMMENT ON TABLE test_table IS 'test comment';
→ COMMENT ON TABLE user_default_schema.test_table IS 'test comment';
```

### 'comment string'

It describes the comments to be stored.

Use the empty string ('') to delete the comments as follows.



```
COMMENT ON TABLE test_table IS '';
```

The length of the comment string can not exceed 1024 bytes.

## Description

The information can be retrieved from the COMMENTS column of the following dictionary view per each object type.

- Cluster objects
  - CLUSTER GROUP & CLUSTER MEMBER
    - DICTIONARY\_SCHEMA.DBA\_CLUSTER\_COMMENTS view
- Non-schema objects
  - DATABASE
    - DICTIONARY\_SCHEMA.ALL\_NONSCHEMA\_COMMENTS view
    - DICTIONARY\_SCHEMA.DBA\_NONSCHEMA\_COMMENTS view
  - PROFILE
    - DICTIONARY\_SCHEMA.DBA\_NONSCHEMA\_COMMENTS view
  - AUDIT POLICY
    - DICTIONARY\_SCHEMA.AUDIT\_POLICIES view
  - USER
    - DICTIONARY\_SCHEMA.ALL\_NONSCHEMA\_COMMENTS view
    - DICTIONARY\_SCHEMA.DBA\_NONSCHEMA\_COMMENTS view
  - TABLESPACE
    - DICTIONARY\_SCHEMA.ALL\_NONSCHEMA\_COMMENTS view
    - DICTIONARY\_SCHEMA.DBA\_NONSCHEMA\_COMMENTS view
  - SCHEMA
    - DICTIONARY\_SCHEMA.ALL\_NONSCHEMA\_COMMENTS view
    - DICTIONARY\_SCHEMA.DBA\_NONSCHEMA\_COMMENTS view
- SQL schema objects
  - TABLE
    - DICTIONARY\_SCHEMA.USER\_TAB\_COMMENTS view
    - DICTIONARY\_SCHEMA.ALL\_TAB\_COMMENTS view
    - DICTIONARY\_SCHEMA.DBA\_TAB\_COMMENTS view
  - VIEW
    - DICTIONARY\_SCHEMA.USER\_TAB\_COMMENTS view
    - DICTIONARY\_SCHEMA.ALL\_TAB\_COMMENTS view
    - DICTIONARY\_SCHEMA.DBA\_TAB\_COMMENTS view
  - COLUMN
    - DICTIONARY\_SCHEMA.USER\_COL\_COMMENTS view

- `DICTIONARY_SCHEMA.ALL_COL_COMMENTS` view
- `DICTIONARY_SCHEMA.DBA_COL_COMMENTS` view
- INDEX
  - `DICTIONARY_SCHEMA.USER_INDEXES` view
  - `DICTIONARY_SCHEMA.ALL_INDEXES` view
  - `DICTIONARY_SCHEMA.DBA_INDEXES` view
- SEQUENCE
  - `DICTIONARY_SCHEMA.USER_SEQUENCES` view
  - `DICTIONARY_SCHEMA.ALL_SEQUENCES` view
  - `DICTIONARY_SCHEMA.DBA_SEQUENCES` view
- CONSTRAINT
  - `DICTIONARY_SCHEMA.USER_CONSTRAINTS` view
  - `DICTIONARY_SCHEMA.ALL_CONSTRAINTS` view
  - `DICTIONARY_SCHEMA.DBA_CONSTRAINTS` view
- PROCEDURE & FUNCTION
  - `DICTIONARY_SCHEMA.USER_PROCEDURES` view
  - `DICTIONARY_SCHEMA.ALL_PROCEDURES` view
  - `DICTIONARY_SCHEMA.DBA_PROCEDURES` view

For more information about the detailed description of each view, refer to `DICTIONARY_SCHEMA`.

## Examples

The following is an example of creating the comment on the table.

```
gSQL> COMMENT ON TABLE t1 IS 'test comment on table t1';  
Comment created.
```

The following is an example of creating the comment on the column.

```
gSQL> COMMENT ON COLUMN t1.id IS 'test comment on column t1.id';  
Comment created.
```

The following is an example of creating the comment on the schema.

```
gSQL> COMMENT ON SCHEMA s1 IS 'test comment on schema s1';  
Comment created.
```

## Compatibility

<comment statement> does not exist in SQL standard.

## 19.3 COMMIT

### Function

It terminates the current transaction and makes all changes permanent.

### Syntax

```

<commit statement> ::=
    COMMIT [ WORK ]
        [ [ <commit comment clause> ] [ <commit write clause> ] ]
        [ <commit force clause> ] [ <commit comment clause> ] ]
    ;
<commit comment clause> ::=
    COMMENT 'comment_string'
<commit write clause> ::=
    WRITE [ WAIT | NOWAIT ]
<commit force clause> ::=
    FORCE 'xid_string'

```

### Syntax Rules and Parameters

#### WORK

It is the reserved word which does not affect the operation.

#### <commit comment clause>

- COMMENT 'comment\_string'
  - It specifies the comment to the transaction when committing the transaction.

#### <commit write clause>

It determines whether to wait until the redo logs generated by the commit operation are written on the redo log file.

- WAIT
  - It waits until the redo logs generated by the commit operation are written to the redo log file, and then the operation is terminated.
- NOWAIT
  - The operation is terminated when the redo logs generated by the commit operation are written to the redo log buffer.
- If it is not specified, it follows the property.

## ⟨commit force clause⟩

It is used to manually commit a distributed transaction.

- FORCE 'xid\_string'
  - It commits the distributed transaction 'xid\_string'.
  - 'xid\_string' consists of '*format\_id.transaction\_id.branch\_id*'.

## Description

COMMIT statement completes the following statements which were executed in a transaction.

- Data Manipulation Language (DML) statement
  - It is the statement which changes data, such as INSERT, UPDATE, DELETE.
- Data Definition Language (DDL) statement
  - It is the statement which changes the structure and definition of the objects, such as CREATE, DROP, ALTER, TRUNCATE, GRANT, REVOKE.

Exceptionally, the following DDL statements which manage the OS resources or change the DATA TYPE are automatically committed.

- CREATE TABLESPACE
- DROP TABLESPACE
- ALTER TABLESPACE
- ALTER TABLE .. ALTER COLUMN .. SET DATA TYPE: ⟨alter column data type clause⟩

When performing COMMIT, the cursor opened by WITHOUT HOLD option is automatically closed. For more information about cursors, refer to the following cursor related statements.

- DECLARE cursor\_name
- OPEN cursor\_name

If the transaction violates the DEFERRED constraint, the COMMIT statement fails and the transaction is rolled back.

led back. For more information about DEFERRED constraint, refer to **SET CONSTRAINTS**.

## Example

The following is an example of performing COMMIT after executing INSERT statement.

```
gSQL> INSERT INTO t1 VALUES ( 1, 'anonymous' );  
1 row created.  
gSQL> COMMIT WORK COMMENT 'INSERT T1';  
Commit complete.
```

## Compatibility

Table 19-2 SQL standard compatibility

Feature ID	Description	Compatibility
T261	Chained transactions	X

## For More Information

Refer to the followings.

- **ROLLBACK**
- **SAVEPOINT** `savepoint_specifier`

## 19.4 CREATE AUDIT POLICY

### Function

It creates an audit policy object.

AUDIT POLICY should be performed to activate the created audit policy object.

### Syntax

```

<audit policy definition> ::=
    CREATE AUDIT POLICY policy_name
    { <privilege_audit_clause> | <action_audit_clause> | <privilege_audit_clause>
<action_audit_clause> }
    ;
<privilege_audit_clause> ::=
    PRIVILEGES <database_privilege> [, ...]
<action_audit_clause> ::=
    ACTIONS { <object_action_audit> | <system_action_audit> } [, ...]
<object_action_audit> ::=
    ALL ON [schema_name.]object_name
    | <object_action> ON [schema_name.]object_name
<system_action_audit> ::=
    ALL
    | DDL
    | <system_action>

```

### Invocation and Access Rules

AUDIT SYSTEM ON DATABASE privilege is required to perform <audit policy definition>.

## Syntax Rules and Parameters

### policy\_name

It is the name of the audit policy to be created.

### <privilege\_audit\_clause>

The privilege audit is auditing when the SQL statement is successfully performed by using the database privilege.

It can audit a specific user performing SQL statement by using the database privilege, and it does not record the privilege audit for SYS user who is the owner of the database.

The following is an example of granting SELECT ANY TABLE privilege to user u1 and activating the audit policy.

```
CREATE AUDIT POLICY p1
    PRIVILEGES SELECT ANY TABLE;
AUDIT POLICY p1;
```

If the user u1 performs the following SQL statement, the privilege audit differently operates.

- SELECT \* FROM u1.t1;
  - It does not create the audit record by performing SQL statement with the privilege as an owner of table u1.t1.
- SELECT \* FROM u2.t1;
  - It creates the audit record by performing SQL statement with SELECT ANY TABLE privilege.

<database\_privilege> which can be described in the privilege audit can be viewed with the following query.

```
SELECT PRIVILEGE_NAME FROM V$AUDITABLE_DB_PRIVILEGES;
```

### <action\_audit\_clause>

It audits an action for a specific object and an action for the entire database.



## <object\_action\_audit>

### ALL ON object\_name

It means all actions which can list objects corresponding to object\_name.

The following table describes audit actions of which each object type can audit.

**Table 19-3** Audit action per object type

Object type	Action
Table	ALTER, COMMENT, DELETE, GRANT, INDEX, INSERT, LOCK, RENAME, SELECT, UPDATE
View	ALTER, COMMENT, GRANT, SELECT
Sequence	ALTER, COMMENT, GRANT, SELECT
Stored Function/Procedure	ALTER, COMMENT, EXECUTE, GRANT

### <object\_action> ON object\_name

Each separate action per a specific object should be listed by specifying ON clause as follows.

```
CREATE AUDIT POLICY p1
  ACTIONS INSERT ON u1.t1
        , DELETE ON u1.t1
        , UPDATE ON u1.t1
;
```

### Caution of EXECUTE action

Auditing the success or the failure of stored function or stored procedure is determined only based on whether it is executable at the time of execution.

- WHENEVER NOT SUCCESSFUL creates the audit record when neither the stored function nor procedure is executable.
- WHENEVER SUCCESSFUL creates the audit record even though an error occurs while executing SQL statement within the stored function or the procedure
- If an auditing for the failure of SQL statement within the stored function or the procedure is required, then the audit target should include the corresponding SQL statement.

## <system\_action\_audit>

It audits the system action which occurs in the database regardless of a specific object.

- <system\_action>

The valid system action can be retrieved by using the following query.

```
SELECT ACTION_NAME FROM V$AUDITABLE_SYSTEM_ACTIONS;
```

- ALL

It means all system actions.

- DDL

It means all Data Definition Language (DDL).

## Description

An audit policy object is an object which defines auditing targets.

Perform AUDIT POLICY statement to activate an audit policy.

Though it is possible to define and activate multiple audit policies, but it is recommended to maintain certain numbers of audit policies.

It is also recommended to bind multiple small pieces of policies into a small number of groups.

The information about an option of the created audit policy object can be retrieved through AUDIT\_POLICY\_OPTIONS view as follows.

```
SELECT audit_option
       , audit_option_type
       , object_schema
       , object_name
FROM audit_policy_options
WHERE policy_name = 'P1'
;
```

AUDIT_OPTION	AUDIT_OPTION_TYPE	OBJECT_SCHEMA	OBJECT_NAME
DELETE	OBJECT ACTION	U1	T1
INSERT	OBJECT ACTION	U1	T1
UPDATE	OBJECT ACTION	U1	T1

## Creating Audit Record

If an action corresponding to multiple audit policies occurs, then one or more audit records are created.

If similar audit options are listed as follows, then one audit record is created.

- Defining an audit policy

```
CREATE AUDIT POLICY p1
  PRIVILEGES SELECT ANY TABLE
  ACTIONS SELECT;
AUDIT POLICY p1;
```

- Performing an audit action

```
SELECT * FROM other_user.t1;
```

If two different audit options are listed as follows, then two audit records are created.

- Defining an audit policy

```
CREATE AUDIT POLICY p1
  ACTIONS SELECT ON u1.t1
    , SELECT ON u2.t2;
AUDIT POLICY p1;
```

- Performing an audit action

```
SELECT COUNT(*) FROM u1.t1 A, u2.t2 B WHERE A.id = B.id;
```

If multiple audit policies are activated for the same action as follows, then two audit records are created.

- Defining an audit policy

```
CREATE AUDIT POLICY p1
  PRIVILEGES SELECT ANY TABLE;
AUDIT POLICY p1;
CREATE AUDIT POLICY p2
  ACTIONS SELECT;
AUDIT POLICY p2;
```

- Performing an audit action

```
SELECT * FROM other.t1;
```

## Examples

The following is an example of defining an audit policy which audits an privilege.

```
CREATE AUDIT POLICY policy_table
    PRIVILEGES CREATE ANY TABLE
        , DROP ANY TABLE
;
```

The following is an example of defining an audit policy which audits an action for an object.

```
CREATE AUDIT POLICY policy_dml
    ACTIONS INSERT ON u1.t1
        , DELETE ON u1.t1
        , UPDATE ON u1.t1
        , ALL ON u1.t2
;
```

The following is an example of defining an audit policy which audits the system action.

```
CREATE AUDIT POLICY policy_drop
    ACTIONS DROP TABLE, TRUNCATE TABLE
;
```

The following is an example of defining an audit policy which combines all examples above.

```
CREATE AUDIT POLICY policy_group
    PRIVILEGES CREATE ANY TABLE
        , DROP ANY TABLE
    ACTIONS INSERT ON u1.t1
        , DELETE ON u1.t1
        , UPDATE ON u1.t1
        , ALL ON u1.t2
        , DROP TABLE
        , TRUNCATE TABLE
;
```

## Compatibility

The audit policy does not exist in SQL standard.

## For More Information

Refer to the followings.

- Managing audit policy object
  - **CREATE AUDIT POLICY**
  - **DROP AUDIT POLICY**
  - **ALTER AUDIT POLICY**
- Activating/ deactivating audit policy
  - **AUDIT POLICY**
  - **NOAUDIT POLICY**
- Retrieving audit trail: **AUDIT\_TRAIL**
- Clearing audit trail: **ALTER DATABASE CLEAR AUDIT TRAIL**

## 19.5 CREATE CLUSTER GROUP

### Function

It creates a cluster group which is to participate in a cluster system.

### Syntax

```
<cluster group definition> ::=  
    CREATE CLUSTER GROUP group_name  
        <cluster member definition> [, ...]  
    ;  
<cluster member definition> ::=  
    CLUSTER MEMBER member_name <connection attribute> [<member position>]  
<connection attribute> ::=  
    HOST 'address' PORT port_no  
<member position> ::=  
    POSITION DEFAULT  
    | POSITION MAX  
    | POSITION number
```

### Invocation and Access Rules

It can be performed in a cluster system.

ADMINISTRATION ON DATABASE privilege is required to perform <cluster group definition>.

### Syntax Rules and Parameters

#### group\_name

It is the name of a cluster group.

An identical cluster group name or a cluster member name should not exist.

The name length should be shorter than 128 bytes.

## <cluster member definition>

It defines a cluster member to be included in a cluster group.

A cluster group can include maximum 32 cluster members.

A cluster group which is created first in a cluster system can define only one cluster member, and should include itself as a cluster member.

### member\_name

It is the name of a cluster member.

The name of a cluster member should be same as the name of the member which was defines when creating the database of that member.

An identical cluster group name or a cluster member name should not exist.

The name length should be shorter than 128 bytes.

The start-up phase of the cluster member should be the GLOBAL OPEN phase.

## <connection attribute>

It defines the connection information for the communication between the cluster members.

<connection attribute> should be as same as the HOST and PORT which were defined when the database of that cluster member was created.

The combination of HOST and PORT should be unique in the cluster system.

- HOST address uses ip v4 type.
- PORT port\_no should be in the range between 1024 ~ 49151.

## <member position>

It assigns the position number of the cluster member.

- POSITION DEFAULT
  - The system automatically assigns the position number.
- POSITION MAX
  - It assigns the new member position number even when an empty position number exists.
  - It assigns the value bigger than the biggest member position.
- POSITION number
  - It assigns the position number corresponding to the number
  - The position number should be unique in the cluster system.
  - The position number should be an empty position number, and it should be same or smaller than the biggest position number.

- If it is omitted, the default value is POSITION DEFAULT.

The member\_position information of the cluster member can be retrieved through DBA\_CLUSTER view.

```
SELECT member_name, member_id, member_position FROM dba_cluster;
```

If the following position numbers are being used,

- G1N1: 0
- G1N2: 1
- G2N2: 3
- G3N2: 5

The following values are assigned according to each option.

- POSITION DEFAULT
  - It assigns 2 which is an empty value.
- POSITION MAX
  - It assigns 6 which is a value of a new position number.
- POSITION 3
  - It is duplicated, so it is an error.
- POSITION 4
  - It assigns 4 which is a position number.

## Description

<cluster group definition> statement does not rebalance the shard of tables.

Perform the following statements to rebalance the shard to an added cluster group.

- ALTER DATABASE REBALANCE
- ALTER TABLE name REBALANCE

## Examples

The following is an example of creating a cluster group which consists of two cluster members.

```
gSQL>  
CREATE CLUSTER GROUP g1  
  CLUSTER MEMBER g1n1 HOST '192.168.0.11' PORT 10110
```



```
;  
Cluster Group created.  
gSQL>  
ALTER CLUSTER GROUP g1  
    ADD CLUSTER MEMBER g1n2 HOST '192.168.0.12' PORT 10120  
;  
Cluster Group altered.  
gSQL>  
CREATE CLUSTER GROUP g2  
    CLUSTER MEMBER g2n1 HOST '192.168.0.21' PORT 10210,  
    CLUSTER MEMBER g2n2 HOST '192.168.0.22' PORT 10220  
;  
Cluster Group created.
```

## Compatibility

The SQL standard does not define the concepts of the cluster.

## For More Information

Refer to the followings.

- **DROP CLUSTER GROUP**
- **ALTER CLUSTER GROUP name ADD MEMBER**

## 19.6 CREATE CLUSTER LOCATION

### Function

It creates the connection information of a cluster member.

### Syntax

```
<cluster location definition> ::=  
    CREATE CLUSTER LOCATION member_name  
    <cluster connection attribute>  
    ;  
<cluster connection attribute> ::  
    HOST 'address' PORT port_no
```

### Invocation and Access Rules

It can be performed in a cluster system.

ADMINISTRATION ON DATABASE privilege is required to perform <cluster location definition>.

### Syntax Rules and Parameters

#### member\_name

It is the name of a cluster member.

The same cluster member name should not exist in the registered cluster location information.

The length of the name should be shorter than 128 bytes.

#### <cluster connection attribute>

It defines the connection information for the communication between the cluster members.

The combination of HOST and PORT should be unique in the cluster system.

- HOST address uses ip v4 type.
- PORT port\_no should be in the range between 1024 ~ 49151.

## Description

Generally, the information of the cluster location is automatically created by using the connection information provided when creating the cluster group or adding the cluster member. The created information is deleted together when deleting the cluster member and the cluster group.

If the information of the cluster location is modified, then the connection information can be modified by using **ALTER CLUSTER LOCATION** without deleting or recreating the cluster member.

## Examples

```
gSQL>  
CREATE CLUSTER LOCATION g1n2  
    HOST '192.168.0.12' PORT 10120,  
;  
Created
```

## Compatibility

The SQL standard does not define the concepts of the cluster.

## For More Information

Refer to **DROP CLUSTER LOCATION** .

## 19.7 CREATE DISK DATA TABLESPACE

### Function

It defines the disk data tablespace.

### Syntax

```

<disk data tablespace statement> ::=
    CREATE DISK [ DATA ] TABLESPACE tablespace_name
        DATAFILE <disk datafile clause> [, ...]
        [ <data tablespace management clause> [, ...] ]
<disk datafile clause> ::=
    'filename'
        [ SIZE <size clause> | REUSE | SIZE <size clause> REUSE ]
        [ <autoextend clause> ]
        [ AT <domain_name> ]
<autoextend clause>
    AUTOEXTEND { ON [ <next size clause> ] [ <max size clause> ] | OFF }
<next size clause>
    NEXT <size clause>
<max size clause>
    MAXSIZE { <size clause> | UNLIMITED }
<size clause> ::=
    integer [ K | M | G | T ]
<data tablespace management clause> ::=
    { ONLINE | OFFLINE }
    | EXTSIZE <size clause>

```

### Invocation and Access Rules

CREATE TABLESPACE ON DATABASE privilege is required to perform <disk data tablespace definition>.

The user who performed the statement has CREATE OBJECT ON TABLESPACE privilege for the created tablespace.

The following privileges are required to create an object on the created tablespace.

- CREATE OBJECT ON TABLESPACE for the tablespace
- USAGE TABLESPACE ON DATABASE

## Syntax Rules and Parameters

### tablespace\_name

It is the name of the tablespace to be created.

The length of the tablespace name should be shorter than 128 bytes.

### <disk datafile clause>

- 'filename'
  - It is the name of the file which stores and manages the data.
  - It is the space to store tables and index pages which were created in the disk tablespace.
  - filename is either a new file or an existing file.
  - filename length should be shorter than 1024 bytes.
- SIZE <size clause>
  - If it is a new file, then it specifies the initial size by using SIZE clause.
  - If a file exists, then an error occurs.
  - The file size can be in the range between 1 M ~ maximum 30 G.
- REUSE
  - If it is an existing file, then it uses REUSE clause.
  - If a file does not exist, then it creates a new file.
  - The size of the newly created files is determined by USER\_DATA\_TABLESPACE\_SIZE property.
- SIZE <size clause> REUSE
  - If both SIZE clause and REUSE clause are specified, then it is operated according to the existence of filename as follows.
    - If it is a new filename, then it specifies the initial file size by using SIZE clause.
    - If it is an existing filename, then it adjust the size to the value in SIZE clause.

### <autoextend clause>

It sets the automatic expand property to ON or OFF. If it is set to ON, then it can specify the automatic expanded size and the maximum size of the data file.

## <next size clause>

It specifies the size to be extended when the data file in use does not have available space.

## <max size clause>

It specifies the maximum expanded size of the data file.

## <size clause>

It specifies the file size in byte. (If it is omitted, the default unit is bytes.)

- K: Kilobytes
- M: Megabytes
- G: Gigabytes
- T: Terabytes

## <domain\_name>

It is the name of member or the group to performs the statement.

If it is omitted, then it is performed for all groups.

## ONLINE | OFFLINE

It determines whether to ONLINE/ OFFLINE the tablespace.

- If it is set to ONLINE, then the tablespace is available as soon as it is created.
- If it is set to OFFLINE, then it is not available, It is available only after it is switched to ONLINE.

## EXTSIZE <size clause>

It specifies the extent size of the tablespace.

- The extent size is specified in byte, and one of the fives (64 K, 128 K, 256 K, 512 K, 1 M) are selected.
- If the extent size is set specified between 64 K ~ 128 K, then it is set to 128 K로, and if it is specifies bigger than 1 M, then it is set to 1 M.

## Description

The data tablespace is an object which provides a physical storage to store SQL schema objects such as a table, and index (LOGGING).

## Examples

The following is an example of creating the disk data tablespace.

```
gSQL> CREATE DISK TABLESPACE space1 DATAFILE 'test_file_1.dbf' SIZE 10M REUSE;  
Tablespace created.
```

The following is an example of creating the tablespace which consists of multiple data files.

```
gSQL> CREATE DISK TABLESPACE space1  
        DATAFILE 'test_file_3_1.dbf' SIZE 10M REUSE,  
                'test_file_3_2.dbf' SIZE 10M REUSE;  
Tablespace created.
```

## Compatibility

The SQL standard does not define the concepts of the tablespace.

## For More Information

Refer to the followings.

- DROP TABLESPACE
- ALTER TABLESPACE
- ALTER DATABASE DATAFILE AUTOEXTEND

## 19.8 CREATE GLOBAL TEMPORARY TABLE

### Function

It creates a new global temporary table.

### Syntax

```

<global temporary table definition> ::=
    CREATE GLOBAL TEMPORARY TABLE table_name
        ( <table element> [, ...] )
        [ <table commit action clause> ]
        [ TABLESPACE tablespace_name ]
    ;
<global temporary table definition: AS query expression> ::=
    CREATE GLOBAL TEMPORARY TABLE table_name
        [ TABLESPACE tablespace_name ]
        AS <query expression> [ WITH [ NO ] DATA ]
    ;
<table commit action clause> ::=
    ON COMMIT { PRESERVE | DELETE } ROWS
  
```



The definition of <table element> is as same as that of <table\_definition>. For more information, refer to **CREATE TABLE**.

### Invocation and Access Rules

A user should satisfy the following conditions to perform <global temporary table definition> statement.

- Table creation privilege
  - Refer to the access privilege in **CREATE TABLE**.
- SELECT access privilege
  - Refer to the access privilege in **SELECT**.



## Syntax Rules and Parameters

### table\_name

It is the table name to be created.

For more information, refer to **table\_name**.

### other syntax

For more information about other syntaxes, refer to the syntax in **CREATE TABLE** and in **CREATE TABLE AS SELECT** statement.

## Description

GLOBAL TEMPORARY TABLE is used to store the data which is maintained while a transaction or a session is performed.

It is used for the purpose as same as that of the variable of which a developer temporarily stores the mid-data of the operation when developing an application.

The global temporary table has the following features.

- The definition of the global temporary table can be viewed in every session.
- The physical segment is not allocated when defining the global temporary table, but the segment subordinated to that session is allocated when it is inserted for the first time.
- The data of the global temporary table can be viewed in a session or a transaction which was inserted.
- The tablespace to store the data of the global temporary table is determined as follows.

Whether to specify tablespace	The tablespace in which the table is created
It specifies the tablespace.	It is created in the specified tablespace.
It does not specify the tablespace.	It is created in the default temporary tablespace of the current session user.

- The index for the global temporary table is subordinate to the same session of the corresponding table, and the time duration is as same as that of the table.
- It can define the view for the global temporary table.
- It can not specify <table sharding strategy> statement which describe the cluster-related features of the table for the global temporary table, nor <table global secondary index clause> statement.
- It can not specify <table attribute clause> which describes the physical attributes of the table for the global temporary table, nor <index attribute clause> which describes the physical attributes of the index.

x.

- <index attribute clause> which describes the physical attributes of the index can not be specified for the index which is created based on the global temporary table.
- If a transaction is terminated by <table commit action clause>, it can determine how to process the remaining data.

Table commit action	Description
ON COMMIT PRESERVE ROWS	It maintains the data remained in a table even after COMMIT or ROLLBACK.
ON COMMIT DELETE ROWS (default)	It deletes all data remained in a table at the time of COMMIT or ROLLBACK (TRUNCATE).

- It supports most of DDLs for an ordinary table. (Including ALTER and TRUNCATE)
  - It does not support CLUSTER-related statement (SHARD and global secondary index-related statement).
  - DDL for the global temporary table which is currently used in its own session or in another session causes an error.
  - DDL is available after removing all segments which is used as TRUNCATE TABLE or COMMIT in all sessions in use.
- It supports all DMLs and select statements for an ordinary table.
- All alteration for the global temporary table (DML) do not leave the redo log.
- All alteration for the global temporary table (DML) leaves the undo log, the location of the undo logs is determined according to TEMP\_UNDO\_ENABLED property.

TEMP_UNDO_ENABLED value	Description
TRUE	The undo log is recorded in the default temporary tablespace of the database system.
FALSE	The undo log is recorded in the undo tablespace of the database system.

- TRUNCATE command for the global temporary table truncates only the segment of the corresponding session.
- If the session is terminated, all segments are TRUNCATED and then returned.

## Examples

The following is an example of performing CREATE GLOBAL TEMPORARY TABLE statement.

```
gSQL> CREATE GLOBAL TEMPORARY TABLE SESSION_TABLE1(
        COL1 CHAR(10)
        ,COL2 VARCHAR2(20)
        ,COL3 NUMBER(10)
```

```
) ON COMMIT DELETE ROWS;
```

Table created.

The following is an example of performing CREATE GLOBAL TEMPORARY TABLE ... AS SELECT statement.

```
gSQL> CREATE GLOBAL TEMPORARY TABLE SESSION_TABLE2
      ON COMMIT PRESERVE ROWS
      AS SELECT *
      FROM EMPLOYEES;
```

Table created.

## Compatibility

CREATE GLOBAL TEMPORARY TABLE and CREATE GLOBAL TEMPORARY TABLE AS SELECT statement follows the definition of SQL standard <table definition>. However, the following is an extension of SQL standard.

- SQL standard require parentheses outside SELECT clause, but it is optional in GOLDILOCKS.
- SQL standard require WITH [NO] DATA clause, but it is optional in GOLDILOCKS.
- The concepts of tablespace in GOLDILOCKS is an extended concept, and it is not supported in SQL standard.

**Table 19-4** SQL standard compatibility

Feature ID	Description	Compatibility
T171	LIKE clause in table definition	X
T172	AS subquery clause in table definition	O
F531	Temporary tables	X
S051	Create table of type	X
S043	Enhanced reference types	X
S081	Subtables	X
T173	Extended LIKE clause in table definition	X
T180	System-versioned tables	X
F692	Extended collation support	X
T174	Identity columns	O
T175	Generated columns	X
S071	SQL paths in function and type name resolution	X
F321	User authorization	O
T322	Extended roles	X
F762	CURRENT_CATALOG	O

Feature ID	Description	Compatibility
F763	CURRENT_SCHEMA	0

## For More Information

Refer to the followings.

- CREATE TABLE
- CREATE TABLE AS SELECT

## 19.9 CREATE IMMUTABLE TABLE

### Function

It creates a new immutable table.

### Syntax

```

<immutable table definition> ::=
    CREATE IMMUTABLE TABLE table_name
        ( <table element> [, ...] )
        [ <table sharding strategy> ]
        [ <table attribute clause> [...] ]
        [ TABLESPACE tablespace_name ]
        [ <table global secondary index clause> ]
    ;

<immutable table definition: AS query expression> ::=
    CREATE IMMUTABLE TABLE table_name
        [ ( column_name [, ...] ) ]
        [ <table sharding strategy> ]
        [ <table attribute clause> [, ...] ]
        [ TABLESPACE tablespace_name ]
        [ <table global secondary index clause> ]
        AS <query expression> [ WITH [ NO ] DATA ]
    ;

```



The definition for <table element>, <table sharding strategy>, <table attribute clause> and <table global secondary index clause> are as same as that of <table\_definition>. For more information, refer to **CREATE TABLE**.

### Invocation and Access Rules

The user should satisfy the following conditions to perform <immutable table definition>.

- The privilege to create the table
  - Refer to the access rules for **CREATE TABLE** statement.
- The privilege for **SELECT** to access
  - Refer to the access rules for **SELECT** statement.

## Syntax Rules and Parameters

### table\_name

It is the table name to be created and it should be unique in the schema.

It can define the schema to which the table belongs, such as schema\_name.table\_name. If schema\_name is omitted, the default schema name of the user performing the statement is used.

The length of the table name should be shorter than 128 byte.

### Other Syntax

For other syntaxes, refer to the syntaxes for **CREATE TABLE** and **CREATE TABLE AS SELECT**.

## Description

An immutable table is used when it is required to prevent the record stored in the table from being altered or deleted and to prevent the table from being dropped.



An immutable table can be dropped when a user, a schema, a tablespace and a cluster group are dropped.



The following SQL statements are not allowed for an immutable table.

- UPDATE
- DELETE
- ALTER TABLE RENAME/DROP COLUMN
- ALTER TABLE SET UNUSED COLUMN
- ALTER TABLE DROP UNUSED COLUMNS
- ALTER TABLE RENAME TO
- TRUNCATE TABLE
- DROP TABLE

The following SQL statements are allowed for an immutable table.

- INSERT
- SELECT
- SELECT .. FOR UPDATE
- CREATE/ALTER/DROP INDEX
- ALTER TABLE ADD/ALTER COLUMN
- ALTER TABLE ADD/ALTER/RENAME/DROP CONSTRAINT
- ALTER TABLE for physical property changes
- ALTER TABLE ADD/DROP SUPPLEMENTAL LOG
- LOCK TABLE
- ALTER TABLE .. ADD/ALTER/DROP GLOBAL SECONDARY INDEX
- ALTER DATABASE MOVE SHARD
- ALTER TABLE .. MOVE SHARD
- ALTER TABLE .. SPLIT SHARD
- ALTER TABLE .. MERGE SHARD
- DROP TABLESPACE
- DROP SCHEMA
- DROP USER
- DROP CLUSTER GROUP

## Examples

The following is an example of executing CREATE IMMUTABLE TABLE statement.

```
gSQL> CREATE IMMUTABLE TABLE t1
(
  id INTEGER PRIMARY KEY,
  name VARCHAR(128),
  addr VARCHAR(128)
);
```

Table created.

The following is an example of executing CREATE IMMUTABLE TABLE ... AS SELECT statement.

```
gSQL> CREATE IMMUTABLE TABLE T2
  AS SELECT *
  FROM T1;
```

Table created.

## Compatibility

The SQL standard does not cover `CREATE IMMUTABLE TABLE` and `CREATE IMMUTABLE TABLE AS SELECT` statements.

## For More Information

Refer to the followings.

- `CREATE TABLE`
- `CREATE TABLE AS SELECT`



## 19.10 CREATE INDEX

### Function

It creates an index.

### Syntax

```

<index definition> ::=
    CREATE [ UNIQUE ] INDEX index_name
        ON table_name ( <index column element> [, ...] )
        [ <index attributes> [...] ]
        [ TABLESPACE tablespace_name ]
    ;
<index column element> ::=
    column_name [ ASC | DESC ] [ NULLS FIRST | NULLS LAST ]
<index attributes> ::=
    <physical attribute clause>
    | STORAGE ( <segment attr clause> [...] )
    | <parallel clause>
<physical attribute clause> ::=
    PCTFREE integer
    | INITTRANS integer
    | MAXTRANS integer
<segment attr clause> ::=
    INITIAL <size_clause>
    | NEXT <size_clause>
    | MINSIZE <size_clause>
    | MAXSIZE <size_clause>
<size clause> ::=
    integer [ K | M | G | T ]
<parallel clause> ::=
    NOPARALLEL
    | PARALLEL [ integer ]

```

## Invocation and Access Rules

The user should satisfy the following conditions to perform <index definition>.

- One of the following privileges is required to create an index on the table.
  - (INDEX or CONTROL TABLE ON) TABLE for that table
  - CONTROL SCHEMA ON SCHEMA for the schema to which the table belongs
  - CREATE ANY INDEX ON DATABASE
- One of the following privileges is required for the schema on which the index is to be created.
  - (CREATE INDEX or CONTROL SCHEMA) ON SCHEMA for the schema
  - CREATE ANY INDEX ON DATABASE
- One of the following privileges is required for the tablespace on which the index is to be created.
  - CREATE OBJECT ON TABLESPACE for that tablespace
  - USAGE TABLESPACE ON DATABASE
- The owner of the index is determined as follow.
  - The owner of the schema to which the index belongs.
  - If the schema to which the index belongs is PUBLIC, then it is the user who executed the statement.



Unique indexes in a cluster system should include all sharding keys.

## Syntax Rules and Parameters

### UNIQUE

It does not allow duplicate values for the columns of the index.

### index\_name

It is the index name to be created and it should be a unique name within the schema.

If the schema name is omitted, the index is created in the schema to which the referring table belongs.

The length of the index name should be shorter than 128 bytes.

## table\_name

It is the table name which creates the index.

The schema to which a table belongs, such as schema\_name.table\_name, can be defined. If schema\_name is omitted, the default schema name of the user performing the statement is used.

## column\_name

It is the column name to be used as an index key.

One or more columns should be defined, and maximum 32 columns can be used as an index key.

The following constraints can occur depending on the implementation.

- If the column data type included in an index is LONG CHARACTER VARYING, LONG BINARY VARYING, an index can not be created.
- An index is created only when the sum of the column precisions is less than 1200 bytes.

## ASC | DESC

It specifies the sort order of a column.

- ASC: It is sorted in ascending order.
- DESC: It is sorted in descending order.
- If not specified, the default value is ASC.

## NULLS FIRST | NULLS LAST

It specifies the sort order of the NULL value.

- NULLS FIRST: It precedes the non-NULL values.
- NULLS LAST: It is behind the non-NULL values.
- If not specified, the default value is NULLS LAST.

## <physical attribute clause>

It defines the physical attribute of the index.

- PCTFREE integer
  - Definition
    - It is the reserved space for adjusting the page split frequency caused by the key inserted in the page.
    - It applies only to the index bottom-up build.

- It can use the value from 0 to 99.
- If it is omitted, the default value is the value set in DEFAULT\_INDEX\_PCTFREE property.
- INITRANS integer
  - Definition
    - It specifies the initial number of transactions which can simultaneously access the page.
    - If the number of users who access the index is small, INITRANS is set to low, and if the number of users who simultaneously access the index is big, INITRANS is set to high.
    - If necessary, it is automatically increased to the specified MAXTRANS.
  - It can use the value from 1 to 32.
  - If it is omitted, the default value is 4.
- MAXTRANS integer
  - Definition
    - It specifies the maximum number of transactions which can simultaneously access the page.
  - It can use the value from 1 to 32.
  - If it is omitted, the default value is 8.

## ⟨segment attr clause⟩

It specifies the information for the index storage space.

- INITIAL integer
  - Definition
    - It specifies the size of physical storage space which is initially allocated when creating the index.
    - This size is aligned to the EXTENT size of the TABLESPACE to which the table belongs. (e.g. If the EXT size is 8192 bytes, 'INITIAL 100' is actually operated as 8192 bytes. )
    - The size (aligned to the EXTENT size of TABLESPACE) should be equal to or bigger than MIN EXTENTS, or it should be equal to or less than MAXEXTENTS.
  - The minimum value is 1, and the maximum value depends on the system environment.
  - If it is omitted, the default value is one EXTENT size of TABLESPACE to which the table belongs.
- NEXT integer
  - Definition
    - It specifies the physical space size to be allocated when adding the space to the table.
    - This size is aligned to the EXTENT size of the TABLESPACE to which the table belongs. (e.g. If the EXT size is 8192 bytes, 'NEXT 100' is actually operated as 8192 bytes.)
    - NEXT operates as follows, depending on the remaining space size of the index available currently. (Obtained by subtracting the amount of currently used space from the MAXEXTENTS size)
  - If the remaining space size is 0, then it can not extend the space.
  - If the remaining space size is bigger than 0, but smaller than NEXT, then it allocates the

space as big as the remaining space.

- If the remaining space size is bigger than NEXT, then it allocates the space as big as the NEXT.

- The minimum value is 1 and the maximum value depends on the system environment.
  - If it is omitted, the default value is one EXTENT size of TABLESPACE to which the index belongs.
- MINSIZE integer
    - Definition
      - It is the minimum space size of the index.
      - The value should be equal to or smaller than MAXSIZE.
    - This size is aligned to the EXTENT size of the TABLESPACE to which the index belongs.
    - The minimum value is 1 and the maximum value depends on the system environment.
    - If it is smaller than the size of two EXTENT, it is specified to the size of two EXTENT.
    - If it is omitted, the default value is the size of two EXTENT.
  - MAXSIZE integer
    - Definition
      - It is the maximum space size of the index.
      - The value should be equal to or bigger than MINSIZE.
    - This size is aligned to the EXTENT size of the TABLESPACE to which the index belongs.
    - The minimum value is 1 and the maximum value depends on the system environment.
    - If it is omitted, the default value is EXTENT size \* 2147483647 (The maximum positive integer of INT32).

## <size clause>

It specifies the file size in bytes. (If the unit is omitted, the default value is bytes.)

- K: Kilobytes
- M: Megabytes
- G: Gigabytes
- T: Terabytes

## NOPARALLEL | PARALLEL [ integer ]

It specifies the number of threads to be used when building an index.

- NOPARALLEL
  - It does not build an index in parallel.
- PARALLEL [integer]
  - It builds an index in parallel.
  - If an integer is omitted or set as 0, then it follows INDEX\_BUILD\_PARALLEL\_FACTOR property.
  - The minimum value of an integer is 0 and the maximum value is 16.

- If the property value is 0, then the system determines the optimal value.
- If it is omitted, the default value is PARALLEL.

## TABLESPACE *tablespace\_name*

It specifies the name of the tablespace in which the index is to be stored.

- When it specifies *tablespace\_name*
  - if *tablespace\_name* is data tablespace, then a LOGGING index is created.
  - if *tablespace\_name* is temporary tablespace or nologging tablespace, then a NOLOGGING index is created.
- When it omits TABLESPACE clause
  - If INDEX TABLESPACE *tablespace\_name* of USER is specified
    - The defined tablespace is used.
  - If INDEX TABLESPACE of USER is NULL
    - The index of the DISK table uses the user's default data tablespace.
    - The index of the MEMORY table uses the user's default temporary tablespace.

## Description

LOGGING index and NOLOGGING index have the following trade-offs.

- LOGGING index
  - Advantage: It does not separately build an index because the index is automatically restored by using the log when starting up the system.
  - Disadvantage: A disk I/O occur because the changes on the index is recorded on the log when altering the row.
- NOLOGGING index
  - Advantage: A disk I/O does not occur for the changes on the index when altering the row.
  - Disadvantage: It automatically rebuilds the index when starting up the system because the log information of the index does not exist.

## Examples

The following is an example of creating the unique index.

```
gSQL> CREATE UNIQUE INDEX idx_t1_id ON t1( id );
Index created.
```

The following is an example of creating an index for multiple columns.

```
gSQL> CREATE INDEX idx_t1_id_name ON t1( id, name );  
Index created.
```

The following is an example of specifying the sort order of the index column.

```
gSQL> CREATE INDEX idx_t1_dept_id ON t1( dept_id DESC );  
Index created.
```

The following is an example of specifying the sort order of NULL value of the index column.

```
gSQL> CREATE INDEX idx_t1_name ON t1( name NULLS FIRST );  
Index created.
```

The following is an example of setting information about the space in which index is stored.

```
gSQL> CREATE INDEX idx_t1_id ON t1( id )  
          STORAGE ( INITIAL 10M NEXT 1M MINSIZE 10M MAXSIZE 100M );  
Index created.
```

The following is an example of creating the redo logging for the index.

```
gSQL> CREATE INDEX idx_t1_id ON t1( id );  
Index created.
```

The following is an example of creating the index with parallel option.

```
gSQL> CREATE INDEX idx_t1_name ON t1( name ) PARALLEL;  
Index created.
```

The following is an example of specifying the tablespace when creating an index.

```
gSQL> CREATE INDEX idx_t1_name ON t1( name ) TABLESPACE mem_temp_tbs;  
Index created.
```

## Compatibility

The SQL standard does not cover the concepts of the index.

## For more information

Refer to **DROP INDEX**.



# 19.11 CREATE MEMORY DATA TABLESPACE

## Function

It defines a memory data tablespace.

## Syntax

```

<memory data tablespace statement> ::=
    CREATE [ MEMORY ] [ DATA ] TABLESPACE tablespace_name
        DATAFILE <memory datafile clause> [, ...]
        [ <data tablespace management clause> [, ...] ]
<memory datafile clause> ::=
    'filename'
        [ SIZE <size clause> | REUSE | SIZE <size clause> REUSE ]
        [ AT <domain_name> ]
<size clause> ::=
    integer [ K | M | G | T ]
<data tablespace management clause> ::=
    { ONLINE | OFFLINE }
    | EXTSIZE <size clause>

```

## Invocation and Access Rules

CREATE TABLESPACE ON DATABASE privilege is required to perform <memory data tablespace definition>

The user who performed the statement has CREATE OBJECT ON TABLESPACE privilege on the created tablespace.

One of the following privileges is required to create the objects on the created tablespace.

- CREATE OBJECT ON TABLESPACE for that tablespace
- USAGE TABLESPACE ON DATABASE

## Syntax Rules and Parameters

### [ MEMORY ] [ DATA ]

It is a memory tablespace to store the permanent objects such as tables, indexes, etc.

The reserved words, MEMORY and DATA, can be omitted.

### tablespace\_name

It is the tablespace name to be created.

The length of the tablespace name should be shorter than 128 bytes.

### <memory datafile clause>

- 'filename'
  - It is the file name to store and manage the data.
  - It is the space to store the checkpoint image for the memory data.
  - filename can be either a new file or an already existing file.
  - The length of the filename should be shorter than 1024 bytes.
- SIZE <size clause>
  - The initial size is assigned for a new file by using the SIZE clause.
  - An error occurs if the file already exists.
  - The file size can be specified between minimum 1M and maximum 30G.
- REUSE
  - If the file already exists, REUSE clause is used.
  - If the file does not exist, a new file is created.
  - The newly created file size is
    - determined by USER\_DATA\_TABLESPACE\_SIZE property in case of the data tablespace.
    - determined by USER\_TEMP\_TABLESPACE\_SIZE property in case of the temporary tablespace.
- SIZE <size clause> REUSE
  - If both SIZE clause and REUSE clause are specified, it is operated as follows according to the presence of the filename.
    - For the new filename, the initial file size is assigned by using the SIZE clause.
    - For the existing filename, the size is adjusted to the value of SIZE clause by using the existing file.

## <size clause>

It specifies the file size in bytes. (If it is omitted, the default unit is bytes.)

- K: Kilobytes
- M: Megabytes
- G: Gigabytes
- T: Terabytes

## <domain name>

It is a name of a member or a group for which the statement is performed.

If it is omitted, it is performed for all groups.

## ONLINE | OFFLINE

It sets ONLINE or OFFLINE of the tablespace.

- ONLINE is the state which a tablespace can be used as soon as it is created.
- OFFLINE is the state which a tablespace is unable to be used, it can be used after switching to ONLINE state.

## EXTSIZE <size clause>

It specifies extent size of the tablespace.

- The extent size is specified in bytes, and one of the five (64K, 128K, 256K, 512K, 1M) is selected.
- If the extent size is defined as a value between 64K ~ 128K, 128K is set. If the extent size is defined as 1M or bigger, 1M is set.

## Description

The data tablespace is an object which provides the physical space to store the SQL schema object such as a table, an index (LOGGING).

## Examples

The following is an example of creating a memory data tablespace.

```
gSQL> CREATE TABLESPACE space1 DATAFILE 'test_file_1.dbf' SIZE 10M REUSE;  
Tablespace created.
```

The following is an example of creating a tablespace which consists of multiple data files.

```
gSQL> CREATE TABLESPACE space1  
        DATAFILE 'test_file_3_1.dbf' SIZE 10M REUSE,  
        'test_file_3_2.dbf' SIZE 10M REUSE;  
Tablespace created.
```

## Compatibility

The SQL standard does not cover the concepts of the tablespace.

## For More Information

Refer to the followings.

- **DROP TABLESPACE**
- **ALTER TABLESPACE**

# 19.12 CREATE MEMORY TEMPORARY TABLESPACE

## Function

It defines a memory temporary tablespace.

## Syntax

```
<memory temporary tablespace statement> ::=  
    CREATE [ MEMORY ] TEMPORARY TABLESPACE tablespace_name  
        MEMORY <memory clause> [, ...]  
        <temporary tablespace management clause>  
<memory clause>  
    'memory_name' { SIZE <size clause> } [ AT <domain_name> ]  
<temporary tablespace management clause> ::=  
    EXTSIZE <size clause>
```

## Invocation and Access Rules

CREATE TABLESPACE ON DATABASE privilege is required to perform <memory temporary tablespace definition>.

The user who performed the statement has CREATE OBJECT ON TABLESPACE privilege on the created tablespace.

One of the following privileges is required to create the objects on the created tablespace.

- CREATE OBJECT ON TABLESPACE for the tablespace.
- USAGE TABLESPACE ON DATABASE

## Syntax Rules and Parameters

### [ MEMORY ] TEMPORARY

It is a memory temporary tablespace to store the no logging indexes or the temporary objects such as intermediate results which are generated during the query processing.

The reserved word, MEMORY, can be omitted.

#### tablespace\_name

It is the tablespace name to be created.

The length of the tablespace name should be shorter than 128 bytes.

#### <memory clause>

- 'memory\_name'
  - It is a memory name to store the temporary data.
  - memory\_name should be guaranteed to be unique within the tablespace.
  - The length of the memory\_name should be shorter than 1024 bytes.
- SIZE <size clause>
  - It specifies the initial size.
  - It can be specified between minimum 1M and maximum 30G.

#### <size clause>

It specifies the size of shared memory space in bytes.(If it is omitted, the default unit is bytes.)

The image is not managed as a file in case of the temporary memory data.

- K: Kilobytes
- M: Megabytes
- G: Gigabytes
- T: Terabytes

#### <domain name>

It is a name of a member or a group for which the statement is performed.

If it is omitted, it is performed for all groups.

## EXTSIZE <size clause>

It specifies extent size of the tablespace.

- The extent size is specified in bytes, and one of the five (64K, 128K, 256K, 512K, 1M) is selected.
- If the extent size is defined as a value between 64K ~ 128K, 128K is set. If the extent size is defined as 1M or bigger, 1M is set.

## Description

The temporary tablespace is an object which provides the physical space to store the SQL schema objects such as an index (NOLOGGING), and to store the intermediate results for sorting, hashing during the query processing.

## Examples

The following is an example of creating a temporary tablespace.

```
gSQL> CREATE TEMPORARY TABLESPACE temp_space1 MEMORY 'test_memory_1' SIZE 10M;  
Tablespace created.
```

The following is an example of creating a temporary tablespace which includes multiple memory spaces.

```
gSQL> CREATE TEMPORARY TABLESPACE temp_space1  
        MEMORY 'test_memory_3_1' SIZE 10M,  
        'test_memory_3_2' SIZE 10M;  
Tablespace created.
```

## Compatibility

The SQL standard does not cover the concepts of the tablespace.

## For More Information

Refer to the followings.

- `DROP TABLESPACE`
- `ALTER TABLESPACE`



## 19.13 CREATE PROFILE

### Function

It is the statement which creates the profile, and it sets the password management method.

When a profile is allocated to a user, the user's password is managed in the way defined in the profile.

### Syntax

```

<profile definition> ::=
    CREATE PROFILE profile_name LIMIT
    { <password_parameters>, ... }
    ;

<password parameters> ::=
    FAILED_LOGIN_ATTEMPTS { integer | UNLIMITED | DEFAULT }
    | PASSWORD_LOCK_TIME { password_parameter_number_interval | UNLIMITED | DEFAULT }
    | PASSWORD_LIFE_TIME { password_parameter_number_interval | UNLIMITED | DEFAULT }
    | PASSWORD_GRACE_TIME { password_parameter_number_interval | UNLIMITED | DEFAULT }
    | PASSWORD_REUSE_MAX { integer | UNLIMITED | DEFAULT }
    | PASSWORD_REUSE_TIME { password_parameter_number_interval | UNLIMITED | DEFAULT }
    | PASSWORD_VERIFY_FUNCTION { <verify_policy> | NULL | DEFAULT }

<verify_policy> ::=
    KISA_VERIFY_FUNCTION
    | ORA12C_VERIFY_FUNCTION
    | ORA12C_STRONG_VERIFY_FUNCTION
    | VERIFY_FUNCTION_11G
    | VERIFY_FUNCTION

<password_parameter_number_interval> ::=
    integer
    | integer / integer
  
```

### Invocation and Access Rules

CREATE PROFILE ON DATABASE privilege is required to perform <profile definition>.

## Syntax Rules and Parameters

### **profile\_name**

It specifies the profile name to be created.

### **password\_parameters**

It sets the parameters for password management.

- The following parameters are to be set.
  - FAILED\_LOGIN\_ATTEMPTS
  - PASSWORD\_LOCK\_TIME
  - PASSWORD\_LIFE\_TIME
  - PASSWORD\_GRACE\_TIME
  - PASSWORD\_REUSE\_MAX
  - PASSWORD\_REUSE\_TIME
  - PASSWORD\_VERIFY\_FUNCTION

The omitted parameters follows the "DEFAULT" profile policy.

### **FAILED\_LOGIN\_ATTEMPTS**

It sets the number of consecutive login attempts allowed to fail.

If the failed attempts exceed the specified number, the account is locked.

- FAILED\_LOGIN\_ATTEMPTS integer
  - The value range should be a positive integer bigger than 0.
- FAILED\_LOGIN\_ATTEMPTS UNLIMITED
  - Account lockout which is due to a login failure does not occur.
- FAILED\_LOGIN\_ATTEMPTS DEFAULT
  - It follows the "DEFAULT" profile policy.

### **PASSWORD\_LOCK\_TIME**

It sets the period (days) which the account is locked after consecutive login failure.

- PASSWORD\_LOCK\_TIME constant\_expression
  - It is the lock duration (day).
  - The default unit is a day.
  - Hours(n/24), minutes (n/1440), seconds (n/86400) can be specified for testing.

- The value range is from one second (1/86400) to 100,000 days.
- PASSWORD\_LOCK\_TIME UNLIMITED
  - If an account lockout occurs, the lock is not release until performing ALTER USER user\_name ACCOUNT UNLOCK statement.
- PASSWORD\_LOCK\_TIME DEFAULT
  - It follows the "DEFAULT" profile policy.

## PASSWORD\_LIFE\_TIME

It sets the life time of the password (day).

- PASSWORD\_LIFE\_TIME constant\_expression
  - It is the life time of the password (day).
  - The default unit is a day.
  - Hours(n/24), minutes (n/1440), seconds (n/86400) can be specified for testing.
  - The value range is from one second (1/86400) to 100,000 days.
- PASSWORD\_LIFE\_TIME UNLIMITED
  - The password does not have the expiration date.
- PASSWORD\_LIFE\_TIME DEFAULT
  - It follows the "DEFAULT" profile policy.

## PASSWORD\_GRACE\_TIME

It sets the grace period of password expiration when logging in after PASSWORD\_LIFE\_TIME.

- PASSWORD\_GRACE\_TIME constant\_expression
  - The grace period for password expiration (day)
  - The default unit is a day.
  - Hours (n/24), minutes (n/1440), seconds (n/86400) can be specified for testing.
  - The value range is from one second (1/86400) to 100,000 days.
- PASSWORD\_GRACE\_TIME UNLIMITED
  - It continues to defer the password expiration.
- PASSWORD\_GRACE\_TIME DEFAULT
  - It follows the "DEFAULT" profile policy.

PASSWORD\_GRACE\_TIME starts at first login trial after the password life time. If the password is not altered during the grace period, the password expires.

## PASSWORD\_REUSE\_MAX

It sets the number of the recent passwords which can not be reused when the user wants to reuse the old password.

PASSWORD\_REUSE\_MAX should be used together with PASSWORD\_REUSE\_TIME.

- PASSWORD\_REUSE\_MAX integer
  - The value range should be a positive integer bigger than 0.
- PASSWORD\_REUSE\_MAX UNLIMITED
  - If PASSWORD\_REUSE\_TIME is UNLIMITED, all old passwords can be reused.
  - If PASSWORD\_REUSE\_TIME is not UNLIMITED, any old password can not be reused.
- PASSWORD\_REUSE\_MAX DEFAULT
  - It follows the "DEFAULT" profile policy.

## PASSWORD\_REUSE\_TIME

It sets the duration which the password can not be reused when the user wants to reuse the old password.

PASSWORD\_REUSE\_TIME should be used together with PASSWORD\_REUSE\_MAX.

- PASSWORD\_REUSE\_TIME constant\_expression
  - It is the duration which the password can not be reused. (day)
  - The default unit is a day.
  - Hours(n/24), minutes (n/1440), seconds (n/86400) can be specified for testing.
  - The value range is from one second (1/86400) to 100,000 days.
- PASSWORD\_REUSE\_TIME UNLIMITED
  - If PASSWORD\_REUSE\_MAX is UNLIMITED, all old passwords can be reused.
  - If PASSWORD\_REUSE\_MAX is not UNLIMITED, any old password can not be reused.
- PASSWORD\_REUSE\_TIME DEFAULT
  - It follows the "DEFAULT" profile policy.

## PASSWORD\_VERIFY\_FUNCTION

It sets the password complexity verification methods.

- PASSWORD\_VERIFY\_FUNCTION null
  - The password complexity verification is not performed.
- PASSWORD\_VERIFY\_FUNCTION DEFAULT
  - It follows the "DEFAULT" profile policy.
- PASSWORD\_VERIFY\_FUNCTION <verify policy>
  - The password complexity verification methods can be specified as follows.

- KISA\_VERIFY\_FUNCTION
- ORA12C\_VERIFY\_FUNCTION
- ORA12C\_STRONG\_VERIFY\_FUNCTION
- VERIFY\_FUNCTION\_11G
- VERIFY\_FUNCTION

## KISA\_VERIFY\_FUNCTION

It is the password verification method of KISA (Korea Internet & Security Agency).

- 8 or more letters
- One or more characters
- One or more numbers
- One or more special characters

## ORA12C\_VERIFY\_FUNCTION

It is the password verification method of Oracle, ORA 12C VERIFY\_FUNCTION.

- 8 or more letters
- 1 or more characters
- 1 or more numbers
- The database name should not be included.
- The username or the reversed username should not be included.
- *goldilocks* should not be included.
- *oracle* should not be included.
- The following simple passwords are not allowed.
  - welcome1, database1, account1, user1234, password1, oracle123, computer1, abcdefg1, change\_on\_intall
- At least 3 characters of the new password should be different from the old password.

## ORA12C\_STRONG\_VERIFY\_FUNCTION

It is the password verification method of Oracle, ORA12C\_STRONG\_VERIFY\_FUNCTION.

- 9 or more letters
- 2 or more uppercases
- 2 or more lowercases
- 2 or more numbers
- 2 or more special characters
- At least 4 characters of the new password should be different from the old password.

## VERIFY\_FUNCTION\_11G

It is the password verification method of Oracle, VERIFY\_FUNCTION\_11G.

- 8 or more letters
- 1 or more characters
- 1 or more numbers
- The username should not be included.
- At least 3 characters of the new password should be different from the old password.

## VERIFY\_FUNCTION

It is the password verification method of Oracle, VERIFY\_FUNCTION.

- It should not be as same as the username.
- 4 or more letters
- 1 or more characters
- 1 or more numbers
- 1 or more special characters
- The following simple passwords are not allowed.
  - welcome, database, account, user, password, oracle, computer, abcd
- At least 3 characters of the new password should be different from the old password.

## Description

### Account Lockout

The followings are the parameters affecting the account lockout.

- FAILED\_LOGIN\_ATTEMPTS
- PASSWORD\_LOCK\_TIME

For example, when a user and a profile are created as follows

```
CREATE PROFILE prof LIMIT
  FAILED_LOGIN_ATTEMPTS 4
  PASSWORD_LOCK_TIME 30;
ALTER USER u1 PROFILE prof;
```

If the user u1 fails to log in more than four times, the account is locked for 30 days. Then the account lockout is released after 30 days.

If `PASSWORD_LOCK_TIME` is `UNLIMITED`, the account lockout should be explicitly released by using `ALTER USER` statement.

```
ALTER USER user1 ACCOUNT UNLOCK;
```

## Password Expiration

The followings are the parameters affecting the password expiration.

- `PASSWORD_LIFE_TIME`
- `PASSWORD_GRACE_TIME`

The password is expired in the following order.

1. The password is set.
  - The time of the password expiration is set to the time elapsed as much as `PASSWORD_LIFE_TIME` since when a password is altered.
  - The password expiration status is `OPEN`, and it allows a normal login.
2. When a user logs in after the password expiration
  - The login succeeds but the password expiration status becomes `EXPIRED (GRACE)` and the following warnings occur.
    - `ERR-28000(16310)`: The password will expire in n days
    - `ERR-28000(16311)`: The password will expire soon
    - The SQL standard does not cover the concepts of password expiration.
    - 28000 is the authentication warning or SQL standard status code of an error. 16310, 16311 are the `GOLDILOCKS` error code.
  - The time of the password expiration is reset to the time elapsed as much as `PASSWORD_GRACE_TIME` since when a user logged in.
3. When a user logs in after the grace time
  - The password expiration status becomes `EXPIRED`, the user can not log in, and the following error occurs.
    - `ERR-28000(16312)`: The password has expired
    - The SQL standard does not cover the concepts of password expiration.
    - 28000 is the authentication warning or SQL standard status code of an error. 16312 is the `GOLDILOCKS` error code.
    - `GOLDILOCKS` internal error code of 16312 should be used to control password reentering using program.

**Table 19-5** Password expiration status transition

Step	Point of time	login	Status
1	The password is changed.	Success	OPEN

Step	Point of time	login	Status
2	PASSWORD_LIFE_TIME is elapsed.	Success with warning	EXPIRED(GRACE)
3	PASSWORD_GRACE_TIME is elapsed.	Error	EXPIRED

The following is another example.

```
CREATE PROFILE prof LIMIT
  PASSWORD_LIFE_TIME 90
  PASSWORD_GRACE_TIME 3;
ALTER USER u1 PROFILE prof;
```

The example above describes that the user u1 succeeds in login after 90 days of password expiration. However, the user receives a warning that the password expires in three days.

If the password is not changed within three days, the password expires.

Once the password expires, it reminds that the new password should be entered when logging in, and the account access is denied.

## Password Reusability

The followings are the parameters affecting the password reusability.

- PASSWORD\_REUSE\_MAX
- PASSWORD\_REUSE\_TIME

The password reusability of the two parameters above are determined according to the following table.

**Table 19-6** Conditions for the password reusability

PASSWORD_REUSE_MAX	PASSWORD_REUSE_TIME	Reusable condition
value	value	It can be reused when both conditions of PASSWORD_REUSE_TIME and PASSWORD_REUSE_MAX are satisfied.
value	UNLIMITED	It can not be reused.
UNLIMITED	value	It can not be reused.
UNLIMITED	UNLIMITED	It can always be reused.

If a profile is created as follows,

```
CREATE PROFILE prof LIMIT
  PASSWORD_REUSE_MAX 5
  PASSWORD_REUSE_TIME 3;
```

the password can not be reused if it is the five recent passwords or the password changed within three d



ays.

The following is an example of the user u1's password change history. If the current password is P # \_000 007 and the current date is 2015-08-08, the reusability of existing passwords is as follows.

**Table 19-7** Examples of password reusability

Password	Password_date	Password reusability
P#_000001	2015-08-01	It can be reused.
P#_000002	2015-08-02	It can be reused.
P#_000003	2015-08-03	It violates REUSE_MAX.
P#_000004	2015-08-04	It violates REUSE_MAX.
P#_000005	2015-08-05	It violates REUSE_MAX, REUSE_TIME.
P#_000006	2015-08-06	It violates REUSE_MAX, REUSE_TIME.
P#_000007	2015-08-07	It violates REUSE_MAX, REUSE_TIME.

The password change history accumulated for checking the password reusability can be deleted by using the following statement.

```
ALTER DATABASE CLEAR PASSWORD HISTORY;
```

## DEFAULT profile

When creating the database, the following "DEFAULT" profile is automatically created. The password parameters of the "DEFAULT" profile are as follows.

**Table 19-8** Configuration of DEFAULT profile

Parameter	Value
FAILED_LOGIN_ATTEMPTS	10
PASSWORD_LOCK_TIME	1
PASSWORD_LIFE_TIME	180
PASSWORD_GRACE_TIME	7
PASSWORD_REUSE_MAX	UNLIMITED
PASSWORD_REUSE_TIME	UNLIMITED
PASSWORD_VERIFY_FUNCTION	NULL

The default values of "DEFAULT" profile have the following characteristics.

- Account lockout
  - The account is locked for one day (PASSWORD\_LOCK\_TIME) after ten consecutive login failure (FAILED\_LOGIN\_ATTEMPTS).
- Password expiration
  - The password expires after the grace period of seven days (PASSWORD\_GRACE\_TIME) after 180

days (PASSWORD\_LIFE\_TIME) are exceeded.

- Password reusability
  - The old password can be reused.
- Password complexity verification
  - It is not performed.

DEFAULT profile can not be dropped but it can be altered as follows.

```
ALTER PROFILE DEFAULT LIMIT ...
```

## Examples

The following is an example of creating the profile to control the account lockout. The account is locked for three days after three consecutive login failures.

```
gSQL> CREATE PROFILE prof1 LIMIT
      FAILED_LOGIN_ATTEMPTS 3
      PASSWORD_LOCK_TIME 3;
```

Profile created.

```
gSQL> COMMIT;
```

Commit complete.

The following is an example of creating the profile to control the password expiration. The life time of the password is 90 days, and the grace time of the password is seven days.

```
gSQL> CREATE PROFILE prof1 LIMIT
      PASSWORD_LIFE_TIME 90
      PASSWORD_GRACE_TIME 7;
```

Profile created.

```
gSQL> COMMIT;
```

Commit complete.

The following is an example of creating the profile to control whether the password is reusable. The following example does not verify the old password when changing the password.

```
gSQL> CREATE PROFILE prof1 LIMIT
      PASSWORD_REUSE_MAX DEFAULT
      PASSWORD_REUSE_TIME DEFAULT;
```

Profile created.

```
gSQL> COMMIT;
```

Commit complete.

The following is an example of creating the profile to control the password complexity check.

```
gSQL> CREATE PROFILE prof1 LIMIT
        PASSWORD_VERIFY_FUNCTION KISA_VERIFY_FUNCTION;
Profile created.
gSQL> COMMIT;
Commit complete.
```

The following is an example of creating the profile by setting all parameter.

```
gSQL> CREATE PROFILE prof1 LIMIT
        FAILED_LOGIN_ATTEMPTS 3
        PASSWORD_LOCK_TIME 3
        PASSWORD_LIFE_TIME 90
        PASSWORD_GRACE_TIME 7
        PASSWORD_REUSE_MAX DEFAULT
        PASSWORD_REUSE_TIME DEFAULT
        PASSWORD_VERIFY_FUNCTION KISA_VERIFY_FUNCTION;
Profile created.
gSQL> COMMIT;
Commit complete.
```

## Compatibility

The SQL standard does not cover the concepts of the profile.

## For More Information

Refer to the followings.

- DROP PROFILE
- ALTER PROFILE
- CREATE USER
- ALTER USER
- ALTER DATABASE CLEAR PASSWORD HISTORY

## 19.14 CREATE SCHEMA

### Function

It defines the schema.

### Syntax

```
<schema definition> ::=
    CREATE SCHEMA <schema name clause>
        [ <schema element> [...] ]
    ;
<schema name clause> ::=
    schema_name
    | AUTHORIZATION user_identifier
    | schema_name AUTHORIZATION user_identifier
<schema element> ::=
    <table definition>
    | <view definition>
    | <index definition>
    | <sequence generator definition>
    | <grant privilege statement>
    | <comment statement>
```

### Invocation and Access Rules

The user should satisfy the following conditions to perform <schema definition>.

- CREATE SCHEMA ON DATABASE privilege is required to create the schema.
- If <schema element> exists, the privilege to perform each <schema element> is required. For more information about the access privilege, refer to *invocation and access rules* in the following statements.
  - CREATE TABLE
  - CREATE VIEW
  - CREATE INDEX

- CREATE SEQUENCE
  - GRANT privileges TO
  - COMMENT ON name IS
- The user who is user\_identifier has the following privileges for the created schema.
    - The owner of the created schema, which is schema\_name
    - The owner of the object which is created by <schema element> clause
  - An appropriate privilege for the schema is required to create an object because a separate privilege on the created schema is not granted.  
 For more information about schema privilege types, refer to <schema privilege> of GRANT privileges TO statement.  
 For more information about usage example, refer to **Examples** of CREATE USER statement.

## Syntax Rules and Parameters

### schema\_name

It is the schema name to be created.

An identical schema name should not exist in the database.

The length of the schema name should be shorter than 128 bytes.

### AUTHORIZATION user\_identifier

If the schema name is omitted, a schema with the same name as the user\_identifier is created.

If the AUTHORIZATION is not specified, the user\_identifier of the user performing the statement is used.

### schema\_name AUTHORIZATION user\_identifier

It specifies the schema name and schema owner to be created.

The owner can not be a role or PUBLIC.

### <schema element>

It defines the objects to be created in the schema along with the schema creation.

The schema\_element is executed in the listed order, and they are separated by a white space without a comma (,).

The object can not be defined in a schema which has different name from the schema to be created.

- The `<grant privilege statement>` can be specified only for the following privileges.
  - `<schema privilege>`
  - `<table privilege>`
  - `<sequence privilege>`
- The `<comment statement>` can be specified only for the following objects.
  - `SCHEMA schema_name`
  - `TABLE [schema_name].table_name`
  - `COLUMN [schema_name].table_name.column_name`
  - `INDEX [schema_name].index_name`
  - `SEQUENCE [schema_name].sequence_name`
  - `CONSTRAINT [schema_name].constraint_name`

## Description

A schema is an object which logically classifies SQL schema objects such as table, view, index, sequence and constraint.

In GOLDILOCKS, the relationship between the user and the schema is 1 : N. In other words, the schema owned by a user may not exist, or the user may own multiple schemas.

The SQL standard does not explicitly define the relationship of the non-schema objects such as user, schema, database, but each DBMS defines the relationship between the non-schema objects as a different concept. Refer to the following note.



### The relationship between user and schema in other DBMS

- Oracle
  - User : schema = 1 : 1
- DB2
  - User : schema = 1 : N
- Postgres
  - User : schema = 1 : N

- MySQL
  - Database : schema = 1 : 1
  - User is a subordinate object of a database (schema).

## Examples

The following is an example of creating a schema.

```
gSQL> CREATE SCHEMA s1;
Schema created.
```

The following is an example of creating a schema and assigning the schema owner.

```
gSQL> CREATE SCHEMA s1 AUTHORIZATION test;
Schema created.
```

The following is an example of creating a schema together with the objects which belong to the schema.

```
gSQL> CREATE SCHEMA s1
      CREATE TABLE t1 ( id INTEGER, name VARCHAR(128) )
      CREATE INDEX idx_t1_id ON t1 ( id )
      COMMENT ON TABLE t1 IS 'comment on s1.t1'
;
Schema created.
```

## Compatibility

Table 19-9 SQL standard compatibility

Feature ID	Description	Compatibility
S071	SQL paths in function and type name resolution	X
F461	Named character sets	X
F171	Multiple schemas per user	O
T332	Extended roles	X

## For More Information

Refer to the followings.

- DROP SCHEMA
- CREATE USER
- CREATE TABLE
- CREATE VIEW
- CREATE INDEX
- CREATE SEQUENCE
- GRANT privileges TO
- COMMENT ON name IS



## 19.15 CREATE SEQUENCE

### Function

It creates a sequence.

### Syntax

```

<sequence generator definition> ::=
    CREATE SEQUENCE [schema_name.] sequence_name
        [ <sequence generator option> [, ...] ]
    ;
<sequence generator option> ::=
    <sequence generator start with option>
    | <basic sequence generator option>
<sequence generator start with option> ::=
    START WITH integer
<basic sequence generator option> ::=
    <sequence generator increment by option>
    | <sequence generator maxvalue option>
    | <sequence generator minvalue option>
    | <sequence generator cycle option>
    | <sequence generator cache option>
<sequence generator increment by option> ::=
    INCREMENT BY integer
<sequence generator maxvalue option> ::=
    MAXVALUE integer
    | (NO MAXVALUE | NOMAXVALUE)
<sequence generator minvalue option> ::=
    MINVALUE integer
    | (NO MINVALUE | NOMINVALUE)
<sequence generator cycle option> ::=
    CYCLE
    | (NO CYCLE | NOCYCLE)
<sequence generator cache option> ::=
    CACHE integer
    | (NO CACHE | NOCACHE)

```

## Invocation and Access Rules

The user should have one of the following privileges to perform `<sequence generator definition>` statement.

- `(CREATE SEQUENCE or CONTROL SCHEMA) ON SCHEMA` for the schema to which the sequence belongs
- `CREATE ANY SEQUENCE ON DATABASE`

The sequence owner is determined as follows.

- The owner of the schema to which the sequence belongs
- If the schema to which the sequence belongs is `PUBLIC`, then it is the user who executed the statement.

The sequence owner has `USAGE ON SEQUENCE WITH GRANT OPTION` privilege.

One of the following privileges is required to use the created sequence.

- `USAGE ON SEQUENCE` for the sequence
- `(USAGE SEQUENCE or CONTROL SCHEMA) ON SCHEMA` for the schema to which the sequence belongs
- `USAGE ANY SEQUENCE ON DATABASE`

## Syntax Rules and Parameters

### `sequence_name`

It is the sequence name to be created, and it should be a unique name within the schema.

The schema to which the sequence belongs, such as `schema_name.sequence_name`, can be defined. If `schema_name` is omitted, the default schema name of the user performing the statement is used.

The length of the sequence name should be shorter than 128 bytes.

### `<sequence generator option>`

If any of `<sequence generator option>` is not used, the following two statements have the same meaning.

- `CREATE SEQUENCE test_seq;`
- `CREATE SEQUENCE test_seq START WITH 1 INCREMENT BY 1 NO MINVALUE NO MAXVALUE NO CYCLE CACHE 20;`

## ⟨sequence generator start with option⟩

It defines the first sequence number to be generated.

Depending on the ascending or the descending order, it has the following features.

- Ascending sequence (INCREMENT BY a positive number)
  - It is used when starting the sequence with bigger sequence value than the minimum value.
  - If START WITH clause is omitted, the default value is the minimum value (MINVALUE value).
- Descending sequence (INCREMENT BY a negative number)
  - It is used when starting the sequence with smaller sequence value than the maximum value.
  - If START WITH clause is omitted, the default value is the maximum value (MAXVALUE value).

## ⟨sequence generator increment by option⟩

It defines the interval of sequence numbers.

The constraints and features are as follows.

- A positive number or a negative number is allowed, but 0 is not allowed.
- The absolute value of the interval should be smaller than the difference between MINVALUE and MAXVALUE.
- The ascending sequence is generated if it is a positive number, and the descending sequence is generated if it is a negative number.
- If INCREMENT BY clause is omitted, the default is a positive number 1.

## ⟨sequence generator maxvalue option⟩

It defines the maximum value of which the sequence can generate.

- MAXVALUE integer
  - The maximum value range is between the minimum (-9,223,372,036,854,775,808) and the maximum (+9,223,372,036,854,775,807) of the 64 bit integer.
  - It should be equal to or bigger than START WITH value, and bigger than MINVALUE value.
- NO MAXVALUE | NOMAXVALUE
  - The maximum value is defined as follows.
    - If it is an ascending sequence, it is the maximum value (+9,223,372,036,854,775,807) of the 64 bit integer.
    - If it is a descending sequence, it is -1.
  - NO MAXVALUE (SQL standard) and NOMAXVALUE are the reserved words with the same meaning, so either of them can be used.
- If MAXVALUE and NO MAXVALUE are not specified, the default value is NO MAXVALUE.

## ⟨sequence generator minvalue option⟩

It defines the minimum value of which the sequence can generate.

- MINVALUE integer
  - The minimum value range is between the minimum (-9,223,372,036,854,775,808) and the maximum (+9,223,372,036,854,775,807) of the 64 bit integer.
  - It should be equal to or smaller than START WITH value, and smaller than MAXVALUE.
- NO MINVALUE | NOMINVALUE
  - The minimum value is defined as follows.
    - If it is an ascending sequence, it is 1.
    - If it is a descending sequence, it is the minimum value (-9,223,372,036,854,775,808) of the 64 bit integer.
  - NO MINVALUE(SQL standard) and NOMINVALUE are the reserved words with the same meaning, so either of them can be used.
- If MINVALUE and NO MINVALUE are not specified, the default value is NO MINVALUE.

## ⟨sequence generator cycle option⟩

It specifies whether to continue generating a value when the sequence value becomes the maximum value or the minimum value.

- CYCLE
  - When the ascending sequence becomes the maximum value, it generates the value again from the minimum value.
  - When the descending sequence becomes the minimum value, it generates the value again from the maximum value.
- NO CYCLE | NOCYCLE
  - When the sequence value becomes the maximum value or the minimum value, it does not generate a sequence value.
  - NO CYCLE(SQL standard) and NOCYCLE are the reserved words with the same meaning, so either of them can be used.
- If CYCLE and NO CYCLE are not specified, the default value is NO CYCLE.

## ⟨sequence generator cache option⟩

For quick access of a sequence, it defines the number of the sequence values to be preloaded in memory. When restarting database, the sequence values loaded in memory are lost, and it starts from the value since being loaded.

- CACHE integer
  - CACHE value should be equal to or bigger than 2.

- CACHE value should not be bigger than CYCLE length, if CYCLE exists.
  - CYCLE length:  $\text{CEIL}(\text{MAXVALUE} - \text{MINVALUE}) / \text{ABS}(\text{INCREMENT})$
- NO CACHE | NOCACHE
  - The sequence values are not preloaded in memory.
- If CACHE and NO CACHE are not specified, the default value is CACHE 20.

## Description

The sequence values of the created sequence objects are used by using **NEXTVAL** and **CURRVAL** functions.

The sequence value does not have a transaction property. The sequence value maintains the most recent value, even when an error occurs in the SQL statement in which the sequence function is used or when an explicit ROLLBACK is performed.

CURRVAL function returns NEXTVAL value from the most recent call by a session.

Therefore, using this feature, the sequence value obtained by NEXTVAL can still be usable in the other SQL statements. However, when the session does not call NEXTVAL, using CURRVAL function generates an error.

## Examples

The object seq1 without the defined sequence options is an ascending sequence of the same meanings as the object seq2 in the following example.

```
gSQL> CREATE SEQUENCE seq1;  
Sequence created.  
gSQL> CREATE SEQUENCE seq2 START WITH 1 INCREMENT BY 1 NO MINVALUE NO MAXVALUE NO CYCLE CACHE  
20;  
Sequence created.
```

The following is an example of a sequence which generates an odd value.

```
gSQL> CREATE SEQUENCE seq1 START WITH 1 INCREMENT BY 2;  
Sequence created.
```

The following is an example of generating sequence which repeatedly generates an even number starting from 0 to 1000.

```
gSQL> CREATE SEQUENCE seq1 START WITH 0 MINVALUE 0 MAXVALUE 1000 INCREMENT BY 2 CYCLE;  
Sequence created.
```

The following is an example of generating a descending sequence starting from -1.

```
gSQL> CREATE SEQUENCE seq1 INCREMENT BY -1;  
Sequence created.
```

## Compatibility

The SQL standard does not define <sequence generator cache option> clause.

**Table 19-10** SQL standard compatibility

Feature ID	Description	Compatibility
T176	Sequence generator support	O

## For More Information

Refer to the followings.

- DROP SEQUENCE
- ALTER SEQUENCE
- NEXTVAL
- CURRVAL

## 19.16 CREATE SYNONYM

### Function

It creates a synonym. A synonym is an alternative name for a table, view, sequence, or another synonym, and it can be used in the following statements.

- DML: SELECT, INSERT, UPDATE, DELETE, LOCK TABLE, CALL
- DDL: GRANT, REVOKE, COMMENT

### Syntax

```
<table definition> ::=  
    CREATE [OR REPLACE] [PUBLIC] SYNONYM [schema_name.]synonym_name  
    FOR [schema_name.]object_name  
    ;
```

### Invocation and Access Rules

The user should satisfy the following conditions to perform <synonym definition> statement.

- CREATE PUBLIC SYNONYM ON DATABASE privilege is required to create public synonym by explicitly specifying PUBLIC.
- The owner of public synonym is PUBLIC. The user who created the synonym does not have any privilege.
- One of the following privileges is required to create the private synonym.
  - (CREATE SYNONYM or CONTROL SCHEMA) ON SCHEMA for that schema
  - CREATE ANY SYNONYM ON DATABASE
- The private synonym owner is determined as follows.
  - The owner of the schema to which the private synonym belongs
  - If the schema to which the private synonym belongs is PUBLIC, then it is the user who executed the statement.
- If the user does not have privilege on the base object, the user is not allowed to execute the statement.

nt using its synonym even when the user created the synonym.

- Be cautious when allowing the privilege on the synonym because it means allowing privilege on the base object to which the synonym indicates.

## Syntax Rules and Parameters

### [ OR REPLACE ]

It replaces the existing synonym If the synonym already exists.

### [ PUBLIC ]

It is specified when creating public synonym.

If it is omitted, private synonym is created.

### synonym\_name

It is the synonym name to be created, and it should be a unique name within the schema.

The schema to which the synonym belongs, such as schema\_name.synonym\_name, can be defined. If schema\_name is omitted, default schema name of the user performing the statement is used.

The length of the synonym name should be shorter than 128 bytes.

Public synonym is a non-schema object. Therefore, a schema name can not be specified when creating public synonym by explicitly specifying PUBLIC.

### object\_name

The schema to which the object belongs, such as schema\_name.object\_name, can be defined. If schema\_name is omitted, default schema name of the user performing the statement is used.

The object types which can specify the object\_name are as follows.

- Table
- View
- Sequence
- Another synonym

Existence of the target object, cycle check and privilege check are performed when executing the statement using the synonym.



## Description

A synonym is an alternative name for a table, view, sequence, or another synonym.

If a synonym is created, the applications does not need to be modified even when the base object is changed instead only the synonyms should be redefined. Therefore, it is convenient.

Also, the database security is improved by hiding the objects' real names and their schemas, and the usability is enhanced by changing the object's long name to a shorter name.

The synonym is literally an alternative name so creating the synonym does not mean that the synonym can be used to access the object. The proper privilege is required to access the object.

When executing the statement using the synonym, the object access procedure is as follows.

1. Find a table of the corresponding name.
2. If the table does not exist, find the private synonym of the corresponding name.
3. If the private synonym does not exist, find the public synonym of the corresponding name.

```
gSQL> CREATE PUBLIC SYNONYM syn1 FOR u1.t1;
Synonym created.
gSQL> CREATE PUBLIC SYNONYM syn2 FOR syn1;
Synonym created.
gSQL> SELECT * FROM syn2;
```

The example above is the object access procedure in SELECT statement.

1. It searched for the table syn2, but it does not exist.
2. It searched for the private synonym syn2, but it does not exist.
3. It searched for the public synonym syn2, and it exists.
  - I. It searched for the table syn1, but it does not exist.
  - II. It searched for the private synonym syn1, but it does not exist.
  - III. It searched for the public synonym syn2, and it exists.
    - i. It searched for the table u1.t1, and it exists.

## Examples

The following is an example of creating a private synonym.

```
gSQL> CREATE SYNONYM MyEmp FOR branch.Employee;
Synonym created.
```

```
gSQL> SELECT * FROM MyEmp;
```

The following is an example of creating a public synonym.

```
gSQL> CREATE PUBLIC SYNONYM MainEmp FOR main.Employee;  
Synonym created.  
gSQL> SELECT * FROM MainEmp;
```

## Compatibility

The SQL standard does not define the CREATE SYNONYM statement.

## For More Information

Refer to [DROP SYNONYM](#).

## 19.17 CREATE TABLE

### Function

It defines a table.

### Syntax

```

<table definition> ::=
    CREATE TABLE table_name
        ( <table element> [, ...] )
        [ <table sharding strategy> ]
        [ <table attribute clause> [...] ]
        [ TABLESPACE tablespace_name ]
        [ <table global secondary index clause> ]
    ;
<table element> ::=
    <column definition>
    | <table constraint definition>
<column definition> ::=
    column_name <data type>
        [ <default clause> | <identity column specification> ]
        [ <column constraint definition> ]
<data type> ::=
    <character string type>
    | <binary string type>
    | <numeric type>
    | <boolean type>
    | <datetime type>
    | <interval type>
<character string type> ::=
    CHARACTER [ ( integer [ <character length units> ] ) ]
    | CHAR [ ( integer [ <character length units> ] ) ]
    | CHARACTER VARYING ( integer [ <character length units> ] )
    | CHAR VARYING ( integer [ <character length units> ] )
    | VARCHAR ( integer [ <character length units> ] )
    | CHARACTER LONG VARYING

```

| LONG VARCHAR

<character length units> ::=

CHARACTERS

| CHAR

| OCTETS

| BYTE

<binary string type> ::=

BINARY [ ( length ) ]

| BINARY VARYING ( length )

| VARBINARY ( length )

| LONG BINARY VARYING

| LONG VARBINARY

<numeric type> ::=

<exact numeric type>

| <approximate numeric type>

| <native numeric type>

<exact numeric type> ::=

NUMERIC [ ( precision [ , scale ] ) ]

| SMALLINT

| INTEGER

| INT

| BIGINT

<approximate numeric type> ::=

| FLOAT [ ( precision ) ]

| REAL

| DOUBLE PRECISION

<native numeric type> ::=

NATIVE\_SMALLINT

| NATIVE\_INTEGER

| NATIVE\_BIGINT

| NATIVE\_REAL

| NATIVE\_DOUBLE

<boolean type> ::=

BOOLEAN

<datetime type> ::=

DATE

| TIME [ ( time\_precision ) ] [ WITH TIME ZONE | WITHOUT TIME ZONE ]

| TIMESTAMP [ ( timestamp\_precision ) ] [ WITH TIME ZONE | WITHOUT TIME ZONE ]

<interval type> ::=

INTERVAL <interval qualifier>

```

<interval qualifier> ::=
    <non-second primary datetime field> [ ( interval_leading_field_precision ) ]
        TO { <non-second primary datetime field> | SECOND [ (
interval_fractional_seconds_precision ) ] }
    | <non-second primary datetime field> [ ( interval_leading_field_precision ) ]
    | SECOND [ ( interval_leading_field_precision [, interval_fractional_seconds_precision ] )
]
<non-second primary datetime field> ::=
    YEAR
    | MONTH
    | DAY
    | HOUR
    | MINUTE
<default clause> ::=
    DEFAULT <default option>
<default option> ::=
    constant
    | NULL
    | expression
<identity column specification> ::=
    GENERATED { ALWAYS | BY DEFAULT } AS IDENTITY
    [ ( <common sequence generator option> [, ...] ) ]
<common sequence generator option> ::=
    START WITH integer_constant
    | <basic sequence generator option>
<basic sequence generator option> ::=
    INCREMENT BY integer_constant
    | { MAXVALUE integer_constant | NO MAXVALUE }
    | { MINVALUE integer_constant | NO MINVALUE }
    | { CYCLE | NO CYCLE }
    | { CACHE integer_constant | NO CACHE }
<column constraint definition> ::=
    [ CONSTRAINT constraint_name ] <column constraint> [ <constraint characteristics> ]
<column constraint> ::=
    NOT NULL
    | { UNIQUE | PRIMARY KEY } [ <index name clause> [ <index attributes> ] [ TABLESPACE
index_tablespace_name ] ]
<index name clause> ::=
    INDEX index_name
<index attributes> ::=
    <index physical attribute clause>

```

```

    | STORAGE ( <segment attr clause> [...] )
<table constraint definition> ::=
    [ CONSTRAINT constraint_name ] <table constraint> [ <constraint characteristics> ]
<table constraint> ::=
    <unique constraint definition> [ <index name clause> [ <index attributes> ] [ TABLESPACE
index_tablespace_name ] ]
<unique constraint definition> ::=
    { UNIQUE | PRIMARY KEY } ( <key column element> [, ...] )
<key column element> ::=
    column_name [ ASC | DESC ] [ NULLS FIRST | NULLS LAST ]
<table sharding strategy> ::=
    <cloned strategy>
    | <hash sharding strategy>
    | <range sharding strategy>
    | <list sharding strategy>
<cloned strategy> ::=
    CLONED [ <clone placement> ]
<clone placement> ::=
    AT CLUSTER WIDE
    | AT CLUSTER GROUP group_list
<hash sharding strategy> ::=
    SHARDING BY [HASH] ( column_list )
    [ <hash shard count> ]
    [ <hash shard placement> ]
<hash shard count> ::=
    SHARD COUNT integer
<hash shard placement> ::=
    AT CLUSTER WIDE
    | AT CLUSTER GROUP group_list
<range sharding strategy> ::=
    SHARDING BY RANGE ( column_list )
    { <cluster-wide range shard placement> | <group-specific range shard placement> }
<cluster-wide range shard placement> ::=
    AT CLUSTER WIDE
    <range shard definition> [, ...]
<group-specific range shard placement> ::=
    <group-specific range shard definition> [, ...]
<group-specific range shard definition> ::=
    <range shard definition> AT CLUSTER GROUP group_name
<range shard definition> ::=
    SHARD range_name VALUES LESS THAN ( <range value clause> )

```

```

<range value clause> ::=
    <range value> [, ...]
<range value> ::=
    constant
    | MAXVALUE
<list sharding strategy> ::=
    SHARDING BY LIST ( column_name )
    { <cluster-wide list shard placement> | <group-specific list shard placement> }
<cluster-wide list shard placement> ::=
    AT CLUSTER WIDE
    <list shard definition> [, ...]
<group-specific list shard placement> ::=
    <group-specific list shard definition> [, ...]
<group-specific list shard definition> ::=
    <list shard definition> AT CLUSTER GROUP group_name
<list shard definition> ::=
    SHARD shard_name VALUES IN ( <list value clause> )
<list value clause> ::=
    <list value> [, ...]
<list value> ::=
    constant
    | NULL
    | DEFAULT
<table attribute clause> ::=
    [ <table physical attribute clause> ]
    | [ STORAGE ( <segment attr clause> [...] ) ]
<table physical attribute clause> ::=
    PCTFREE integer
    | PCTUSED integer
    | INITRANS integer
    | MAXTRANS integer
<index physical attribute clause> ::=
    PCTFREE integer
    | INITRANS integer
    | MAXTRANS integer
<segment attr clause> ::=
    INITIAL <size_clause>
    | NEXT <size_clause>
    | MINSIZE <size_clause>
    | MAXSIZE <size_clause>
<size clause> ::=

```

```

integer [ K | M | G | T ]
<constraint characteristics> ::=
    [ NOT ] DEFERRABLE [ <constraint check time> ]
    | <constraint check time> [ [ NOT ] DEFERRABLE ]
<constraint check time> ::=
    INITIALLY DEFERRED
    | INITIALLY IMMEDIATE
<table global secondary index clause> ::=
    WITH GLOBAL SECONDARY INDEX [ <index attributes> [...] ] [ TABLESPACE tablespace_name ]
    | WITHOUT GLOBAL SECONDARY INDEX

```

## Invocation and Access Rules

The differences between the stand-alone database and the cluster database are as follows.

- Stand-alone
  - It can not define <table sharding strategy>.
  - It can not define <table global secondary index clause>.
- Cluster
  - Constraints of PRIMARY KEY, UNIQUE should include all sharding keys.
  - It can not define the deferrable constraints.

The user should satisfy the following conditions to perform <table definition> statement.

- One of the following privileges is required for the schema in which a table is to be created.
  - (CREATE TABLE or CONTROL SCHEMA) ON SCHEMA for that schema
  - CREATE ANY TABLE ON DATABASE
- One of the following privileges is required for the tablespace in which a table is to be created.
  - CREATE OBJECT ON TABLESPACE for that tablespace
  - USAGE TABLESPACE ON DATABASE
- One of the following privileges is required for the schema in which the constraints are to be created when the constraints exists which were created together.
  - (ADD CONSTRAINT or CONTROL SCHEMA) ON SCHEMA for that schema
  - ALTER ANY TABLE ON DATABASE
- One of the following privileges is required for the tablespace in which the index is to be created when the key constraint is created together.
  - CREATE OBJECT ON TABLESPACE for that tablespace
  - USAGE TABLESPACE ON DATABASE



- The owner of the table is determined as follows.
  - The owner of the schema to which the table belongs
  - If the schema to which the table belongs is PUBLIC, then it is the user who executed the statement.
- The table owner has the following privileges for the created table.
  - The privilege for the table
    - SELECT ON TABLE WITH GRANT OPTION
    - INSERT ON TABLE WITH GRANT OPTION
    - UPDATE ON TABLE WITH GRANT OPTION
    - DELETE ON TABLE WITH GRANT OPTION
    - TRIGGER ON TABLE WITH GRANT OPTION
    - REFERENCES ON TABLE WITH GRANT OPTION
    - LOCK ON TABLE WITH GRANT OPTION
    - INDEX ON TABLE WITH GRANT OPTION
    - ALTER ON TABLE WITH GRANT OPTION
  - The privilege for all columns in the table.
    - SELECT(columns) ON TABLE WITH GRANT OPTION
    - INSERT(columns) ON TABLE WITH GRANT OPTION
    - UPDATE(columns) ON TABLE WITH GRANT OPTION
    - REFERENCES(columns) ON TABLE WITH GRANT OPTION
  - The privilege for the constraint which was generated together
    - The owner of that constraint
    - The owner of the index which was generated together with the constraint

⟨table sharding strategy⟩ statement can be used in a cluster system.

## Syntax Rules and Parameters

### **table\_name**

It is the table name to be created and it should be a unique name within the schema.

The schema to which the table belongs, such as schema\_name.table\_name, can be defined. If schema\_name is omitted, The default schema name of the user performing the statement is used.

The length of the table name should be shorter than 128 bytes.

## <column definition>

It defines the columns which configure the table.

The table should include one or more column definitions.

It can specify the column data type, default value, automatically generated value, and constraints.

## column\_name

It is name of the column which configure a table and each column should have a unique name within the table.

The length of the column name should be shorter than 128 bytes.

## <data type>

- <character string type>
- <binary string type>
- <numeric type>
- <exact numeric type>
- <approximate numeric type>
- <boolean type>
- <datetime type>
- <interval type>
- <interval qualifier>
- <non-second primary datetime field>

It defines the data type of the column.

When defining the column including automatically generated values(<identity column specification>), its data type should be one of SMALLINT, INTEGER or BIGINT.

For more information about data types, refer to **Data Type**.

## <character length units>

It specifies the length unit of a single character for the character type.

- CHARACTERS/ CHAR assigns the maximum bytes of a single character as the length of a single character. Therefore, the length of multi-bytes single character such as Hangul is 1.
- OCTETS/ BYTE assigns one byte for the length of a single character. Therefore, the length of multi-bytes single character such as Hangul is multi-bytes.
- If it is omitted, it follows CHAR\_LENGTH UNITS property which is used when creating the database.

SQL standard define CHARACTERS as a default value.



The default value of the char length unit in other DBMS are as follows.

- Oracle, DB2: OCTETS
- MS-SQL, MySQL, PostgreSQL: CHARACTERS

## [ <default clause> | <identity column specification> ]

It specifies the default value of a column.

<default clause> and <identity column specification> can not be used together.

When both of them are omitted, the default value is NULL.

### <default clause>

The DEFAULT clause defines the default value to be used when DEFAULT is specified in INSERT, UPDATE statements or the corresponding column name is omitted.

- When DEFAULT clause is used
  - e.g. CREATE TABLE t1 ( id INTEGER, name VARCHAR(32) DEFAULT 'anonymous' );
  - When the column is omitted
    - INSERT INTO t1(id) VALUES ( 1 );
    - INSERT INTO t1(id) SELECT id FROM other\_table;
  - When the DEFAULT is specified
    - INSERT INTO t1 DEFAULT VALUES;
    - INSERT INTO t1 VALUES ( 2, DEFAULT );
    - UPDATE t1 SET name = DEFAULT;

The data type of DEFAULT expression should be compatible with the data type of the column.

If the data type is not compatible or the expression is not valid, an error occurs.

```
--# result: error
CREATE TABLE t1 ( c1 INTEGER DEFAULT 1 / 0 );
ERR-22012(12122): divisor is equal to zero
--# result: success
CREATE TABLE t1 ( c1 INTEGER DEFAULT 1 / 1 );
Table created.
```

DEFAULT expression can use any built-in functions but it can not use the followings.

- Logical operators (AND, OR, NOT), comparison operators (=, >, ...)
- Stored function

- Column name
- Subquery expression

## ⟨identity column specification⟩

It defines a column which has automatically generated values.

The table can have only one identity column.

The identity column becomes *not nullable* column even though NOT NULL constraint is not specified.

⟨identity column specification⟩ clause can not be specified together with DEFAULT clause.

⟨identity column specification⟩ clause, like as DEFAULT clause, specifies DEFAULT in INSERT, UPDATE statements or it defines the default value to be used when the column name is omitted.

The generation method is defined as follows.

- GENERATED BY DEFAULT AS IDENTITY

A user defined value is applied if defined, but the value is automatically generated, like as DEFAULT clause, when the default value should be used.

- CREATE TABLE t1 ( id INTEGER GENERATED BY DEFAULT AS IDENTITY, name VARCHAR(32) );
- (O) INSERT INTO t1 VALUES ( 12345, 'GOLDILOCKS' );
  - It inserts the user defined value (12345).
- (O) INSERT INTO t1(name) VALUES ( 'GOLDILOCKS' );
  - It inserts the automatically generated value in an id column.
- (O) INSERT INTO t1(id, name) SELECT other\_id, other\_name FROM other\_table;
  - It inserts the user defined value.
- (O) INSERT INTO t1(name) SELECT other\_name FROM other\_table;
  - It inserts the automatically generated value in an id column.
- (O) UPDATE t1 SET id = 10000 WHERE id = 12345;
  - It inserts the user defined value
- (O) UPDATE t1 SET id = DEFAULT WHERE id = 12345;
  - It inserts the automatically generated value in an id column.

- GENERATED ALWAYS AS IDENTITY

A user can not define the value and the default value should be generated like as DEFAULT clause.

- CREATE TABLE t1 ( id INTEGER GENERATED ALWAYS AS IDENTITY, name VARCHAR(32) );
- (X) INSERT INTO t1 VALUES ( 12345, 'GOLDILOCKS' );
  - Error, a user can not define the value.
- (O) INSERT INTO t1(name) VALUES ( 'GOLDILOCKS' );
  - It inserts the automatically generated value in an id column.
- (X) INSERT INTO t1(id, name) SELECT other\_id, other\_name FROM other\_table;
  - Error, a user can not define the value.

- (O) INSERT INTO t1(name) SELECT other\_name FROM other\_table;
  - It inserts the automatically generated value in an id column.
- (X) UPDATE t1 SET id = 10000 WHERE id = 12345;
  - Error, a user can not define the value.
- (O) UPDATE t1 SET id = DEFAULT WHERE id = 12345;
  - It inserts the automatically generated value in an id column.

For more information about <common sequence generator option> and <basic sequence generator option>, which is an option to create an identity column, refer to **CREATE SEQUENCE**.

## <column constraint definition>

It defines the following constraints for a column.

- NOT NULL constraints
- UNIQUE constraints
- PRIMARY KEY constraints

### constraint\_name

It is the constraint name and it can be omitted.

If the constraint\_name is omitted, it is automatically set as follows.

If the automatically generated name is duplicated, the constraint\_name should be explicitly specified.

- NOT NULL constraints
  - "table\_name" + "\_" + "NOT\_NULL" + "\_" + "column\_name"
- UNIQUE constraints
  - "table\_name" + "\_" + "UNIQUE" + "\_" + "column\_name"
- PRIMARY KEY constraints
  - "table\_name" + "\_" + "PRIMARY\_KEY"

The length of the constraint name should be shorter than 128 bytes.

## NOT NULL Constraint

NULL is not allowed for the column value.

## UNIQUE Constraint

The identical value is not allowed for the column value, but NULL is allowed.

## PRIMARY KEY Constraint

NULL or the identical value is not allowed as the column value. A single PRIMARY KEY constraint can be defined on a single table.

### <index name clause>

It defines the index name to be created when defining UNIQUE constraint and PRIMARY KEY constraint.

- INDEX index\_name
  - It defines the index name for the constraint.
  - It can not be used together with a schema name and it is created in the same schema where the constraint is created.

When defining UNIQUE constraint and PRIMARY KEY constraint, if INDEX clause is omitted, an index which satisfies the constraints is automatically created.

"constraint\_name" + "INDEX" is added to the name of index which is automatically generated.

- <index attributes>
  - It specifies the physical attributes of the index to be created.
  - For more information, refer to **CREATE INDEX**.
- TABLESPACE index\_tablespace\_name
  - It specifies the tablespace where the index is to be created.
  - For more information, refer to **CREATE INDEX**.

### <table constraint definition>

<unique constraint definition>

- When defining a table, the constraints can be classified in two ways depending on the location in the statement.
  - When defining a column, column constraints can be specified by using <column constraint definition>.
  - On the other hand, the table constraint definition clause, <table constraint definition>, can be specified separately from the column definition and the constraints on one or more columns can be specified.

The table constraint definition has the following syntactic difference compared to the column constraint definition.

- NOT NULL constraint
  - It can not be specified by using the table constraint definition.
- It should explicitly specify the column unlike the column constraint definition.
  - UNIQUE constraint <unique constraint definition>
    - UNIQUE ( column\_name [, ...] )
  - PRIMARY KEY CONSTRAINT <unique constraint definition>
    - PRIMARY KEY ( column\_name [, ...] )

## key column element

It specifies the column to be a target of the key.

- column name
  - It is name of the column which creates the key.
- ASC | DESC
  - ASC: It is sorted in an ascending order.
  - DESC: It is sorted in a descending order.
  - If not specified, the default value is ASC.
- NULLS FIRST | NULLS LAST
  - NULLS FIRST: It is located before non-NULL values.
  - NULLS LAST: It is located after non-NULL values.
  - If not specified, the default value is NULLS LAST.

## <table sharding strategy>

It defines the sharding strategy of a table.

It can be defined as one of the four following strategies.

- <cloned strategy>
- <hash sharding strategy>
- <range sharding strategy>
- <list sharding strategy>

If it is omitted, it is determined by **DEFAULT\_SHARDING** property value.

- If DEFAULT\_SHARDING value is 0
  - <cloned strategy>
- If DEFAULT\_SHARDING value is 1
  - <hash sharding strategy>

## <cloned strategy>

It clones all data in a table.

## <clone placement>

It defines the placement strategy of a clone.

- AT CLUSTER WIDE
  - It places clones in all cluster members of all cluster groups in a cluster system.
  - A clone can be relocated by using **ALTER TABLE name REBALANCE** statement when adding a cluster group and a cluster member.
- AT CLUSTER GROUP group\_list
  - It places clones in all cluster members of a specified cluster groups.
  - A clone can be relocated by using **ALTER TABLE name REBALANCE** statement when adding a cluster member in a specified cluster group.
  - Adding a cluster group does not affect the relocation of the clone.
- When it is omitted, the default value is AT CLUSTER WIDE.

## <hash sharding strategy>

It shards the table data according to the hash value of the sharding key.

## SHARDING BY [HASH] ( column\_list )

It defines a sharding key for a hash sharding.

- It can list maximum 32 columns.
- It can not use a duplicate column.
- It can not use a LONG VARCHAR type column or a LONG VARBINARY type column.

## <hash shard count>

It defines the number of the hash shards to be sharded.

The number of shards can be defined from 1 to 512.

If it is omitted, the default value is 24.

## <hash shard placement>

It defines the placement strategy of a hash shard.



- AT CLUSTER WIDE
  - It places shards in all cluster members of all cluster groups in a cluster system.
  - A shard can be relocated by using **ALTER TABLE name REBALANCE** statement when adding a cluster group and a cluster member.
- AT CLUSTER GROUP group\_list
  - It places hash shards in all cluster members of a specified cluster groups.
  - The number of group\_list should be equal to or smaller than the value of <hash shard count>.
  - Unlike a range shard and a list shard, the cluster group on which the specific hash shard is to be located can not be specified, but the system automatically determines a cluster group on which the shard is to be located.
  - A shard can be relocated by using **ALTER TABLE name REBALANCE** statement when adding a cluster member in a specified cluster group.
  - Adding a cluster group does not affect the relocation of the hash shard.
- When it is omitted, the default value is AT CLUSTER WIDE.

## <range sharding strategy>

It shards the table data according to the range value of the sharding key.

## SHARDING BY RANGE ( column\_list )

It defines a sharding key for the range sharding.

- It can list maximum 32 columns.
- It can not use a duplicate column.
- It can not use a LONG VARCHAR type column or a LONG VARBINARY type column.

## <cluster-wide range shard placement>

It automatically places range shards in all cluster groups of a cluster system.

AT CLUSTER WIDE statement is described before describing <range shard definition>.

Shards can be relocated by using **ALTER TABLE name REBALANCE** statement when adding a cluster group and a cluster member.

- Create a range sharded table.
- Place six shards in the existing cluster groups (g1, g2, g3).

```
CREATE TABLE t1
(
  id  INTEGER,
  name VARCHAR(32)
)
```

```
SHARDING BY RANGE (id)
  AT CLUSTER WIDE
  SHARD s1 VALUES LESS THAN ( 200000 ),
  SHARD s2 VALUES LESS THAN ( 400000 ),
  SHARD s3 VALUES LESS THAN ( 500000 ),
  SHARD s4 VALUES LESS THAN ( 600000 ),
  SHARD s5 VALUES LESS THAN ( 800000 ),
  SHARD s6 VALUES LESS THAN ( MAXVALUE )
;
```

- Add a cluster group.

```
CREATE CLUSTER GROUP g4
  CLUSTER MEMBER g4n1 HOST '192.168.0.41' PORT 10401
;
```

- Relocate the range shard.
- Place six shards in the cluster groups (g1, g2, g3, g4) including the added g4.

```
ALTER TABLE t1 REBALANCE;
```

## ⟨group-specific range shard placement⟩

It places range shards in a specified cluster group.

It describes `AT CLUSTER GROUP group_name` statement which places that shard together with ⟨range shard definition⟩.

Shards can be automatically relocated by using `ALTER TABLE name REBALANCE` statement when adding a cluster member to a specified cluster group.

Adding a cluster group does not affect the relocation of the range shard.

- Create a range sharded table.
- Place each range shard in a specified cluster group.

```
CREATE TABLE t1
(
  id INTEGER,
  name VARCHAR(32)
)
SHARDING BY RANGE (id)
  SHARD s1 VALUES LESS THAN ( 200000 ) AT CLUSTER GROUP g1,
  SHARD s2 VALUES LESS THAN ( 400000 ) AT CLUSTER GROUP g2,
```

```

SHARD s3 VALUES LESS THAN ( 500000 ) AT CLUSTER GROUP g3,
SHARD s4 VALUES LESS THAN ( 600000 ) AT CLUSTER GROUP g2,
SHARD s5 VALUES LESS THAN ( 800000 ) AT CLUSTER GROUP g3,
SHARD s6 VALUES LESS THAN ( MAXVALUE ) AT CLUSTER GROUP g1
;

```

- Add a cluster group.

```

CREATE CLUSTER GROUP g4
    CLUSTER MEMBER g4n1 HOST '192.168.0.41' PORT 10401
;

```

- Relocate a range shard.
- The shard is not placed in a newly created cluster group g4.

```
ALTER TABLE t1 REBALANCE;
```

## ⟨range shard definition⟩

SHARD range\_name should be unique in a table.

It can define maximum 512 of ⟨range shard definition⟩.

The listed ⟨range shard definition⟩ is sorted in an order of ⟨range value clause⟩, and it should use each different ⟨range value clause⟩.

The ⟨range shard definition⟩ whose all values are define as MAXVALUE is a MAX shard. MAX shard should exist, and it should be a single one.

- It should include a MAX shard.

```

gSQL>
CREATE TABLE t1
(
    id INTEGER,
    name VARCHAR(32)
)
SHARDING BY RANGE (id)
    AT CLUSTER WIDE
    SHARD s1 VALUES LESS THAN ( 100000 ),
    SHARD s2 VALUES LESS THAN ( 200000 ),
    SHARD s3 VALUES LESS THAN ( MAXVALUE )

```

;

Table created.

- If it does not include a MAX shard, then an error occurs.

```

gSQL>
CREATE TABLE t1
(
  id INTEGER,
  name VARCHAR(32)
)
SHARDING BY RANGE (id)
  AT CLUSTER WIDE
  SHARD s1 VALUES LESS THAN ( 100000 ),
  SHARD s2 VALUES LESS THAN ( 200000 ),
  SHARD s3 VALUES LESS THAN ( 300000 )
;
ERR-42000(16377): MAX shard not defined :
  SHARD s3 VALUES LESS THAN ( 300000 )
*
ERROR at line 10:

```

## <range value clause>

<range value> should be a constant or a MAXVALUE (a maximum value).

NULL can not be used as <range value>.

- (O) SHARD s1 VALUES LESS THAN ( 1 )
- (O) SHARD s2 VALUES LESS THAN ( 1 + 1 )
- (O) SHARD s3 VALUES LESS THAN ( MAXVALUE )
- (X) SHARD s4 VALUES LESS THAN ( SYSDATE )
- (X) SHARD s5 VALUES LESS THAN ( NULL )

MAXVALUE is always bigger than any other value, and it includes null.

If there are multiple sharding keys, only a MAXVALUE can be specified after the MAXVALUE.

- (O) SHARD s1 VALUES LESS THAN ( 100, MAXVALUE )
- (X) SHARD s2 VALUES LESS THAN ( MAXVALUE, 100 )
- (O) SHARD s3 VALUES LESS THAN ( MAXVALUE, MAXVALUE )

If a sharding key is defined by using multiple columns, a MAX shard which is listed with MAXVALUE for it

s all values as like the SHARD s3 below should exist.

```
CREATE TABLE t1
(
  id INTEGER,
  name VARCHAR(32)
)
SHARDING BY RANGE (id, name)
  AT CLUSTER WIDE
  SHARD s1 VALUES LESS THAN ( 100000, MAXVALUE ),
  SHARD s2 VALUES LESS THAN ( 200000, 200000 ),
  SHARD s3 VALUES LESS THAN ( MAXVALUE, MAXVALUE )
;
```

## ⟨list sharding strategy⟩

It shards the table data according to the listed value of the sharding key.

## SHARDING BY LIST ( column\_name )

It defines a sharding key for a list sharding.

- It can use only one column.
- It can not use a LONG VARCHAR type column or a LONG VARBINARY type column.

## ⟨cluster-wide list shard placement⟩

It automatically places list shards in all cluster groups of a cluster system.

AT CLUSTER WIDE statement is described before describing ⟨range shard definition⟩.

Shards can be relocated by using **ALTER TABLE name REBALANCE** statement when adding a cluster group and a cluster member.

- Create a list sharded table.
- Place five shards in the existing cluster groups (g1, g2, g3).

```
CREATE TABLE city
(
  id INTEGER,
  name VARCHAR(32)
)
SHARDING BY LIST (name)
```

```

AT CLUSTER WIDE
SHARD s1 VALUES IN ( 'SEOUL' ),
SHARD s2 VALUES IN ( 'PUSAN', 'ULSAN', 'DAEGU' ),
SHARD s3 VALUES IN ( 'DAEJEON', 'GWANGJU' ),
SHARD s4 VALUES IN ( 'ANSAN', 'GOYANG' ),
SHARD s5 VALUES IN ( DEFAULT )
;

```

- Add a cluster group.

```

CREATE CLUSTER GROUP g4
    CLUSTER MEMBER g4n1 HOST '192.168.0.41' PORT 10401
;

```

- Relocate a list shard.
- Place five shards in the cluster groups (g1, g2, g3, g4) including the added g4.

```

ALTER TABLE t1 REBALANCE;

```

## ⟨group-specific list shard placement⟩

It places list shards in a specified cluster group.

It describes AT CLUSTER GROUP group\_name statement which places that shard together with ⟨list shard definition⟩.

Shards can be automatically relocated by using **ALTER TABLE name REBALANCE** statement when adding a cluster member to a specified cluster group.

Adding a cluster group does not affect the relocation of the list shard.

- Create a list sharded table.
- Place each list shard in a specified cluster group.

```

CREATE TABLE city
(
    id INTEGER,
    name VARCHAR(32)
)
SHARDING BY LIST (name)
    SHARD s1 VALUES IN ( 'SEOUL' ) AT CLUSTER GROUP g1,
    SHARD s2 VALUES IN ( 'PUSAN', 'ULSAN', 'DAEGU' ) AT CLUSTER GROUP g2,
    SHARD s3 VALUES IN ( 'DAEJEON', 'GWANGJU' ) AT CLUSTER GROUP g3,
    SHARD s4 VALUES IN ( 'ANSAN', 'GOYANG' ) AT CLUSTER GROUP g2,

```

```
SHARD s5 VALUES IN ( DEFAULT )
                                AT CLUSTER GROUP g1
;
```

- Add a cluster group.

```
CREATE CLUSTER GROUP g4
      CLUSTER MEMBER g4n1 HOST '192.168.0.41' PORT 10401
;
```

- Relocate a list shard.
- The shard is not placed in a newly added cluster group g4.

```
ALTER TABLE t1 REBALANCE;
```

## <list shard definition>

LIST list\_name should be unique in a table.

It can define maximum 512 of <list shard definition>.

All <list value> of the listed <list shard definition> should be different each other.

DEFAULT are other values which is not the listed <list value>.

DEFAULT can not be defined together with another value.

A shard including DEFAULT is a DEFAULT shard.

MAX shard should exist, and it should be a single one.

- It should include a DEFAULT shard.

```
gSQL>
CREATE TABLE t1
(
  category INTEGER,
  name     VARCHAR(32)
)
SHARDING BY LIST (category)
      AT CLUSTER WIDE
      SHARD s1 VALUES IN ( 1, 3, 5, 7 ),
      SHARD s2 VALUES IN ( 2, 4, 6, 8 ),
      SHARD s3 VALUES IN ( DEFAULT )
;
```

Table created.

- If it does not include a DEFAULT shard, then an error occurs.

```

gSQL>
CREATE TABLE t1
(
  category INTEGER,
  name      VARCHAR(32)
)
SHARDING BY LIST (category)
  AT CLUSTER WIDE
  SHARD s1 VALUES IN ( 1, 3, 5, 7 ),
  SHARD s2 VALUES IN ( 2, 4, 6, 8 ),
  SHARD s3 VALUES IN ( 9, 10 )
;
ERR-42000(16385): DEFAULT shard not defined :
  SHARD s3 VALUES IN ( 9, 10 )
*
ERROR at line 10:

```

## ⟨list value clause⟩

⟨list value⟩ should be a constant.

NULL or DEFAULT can be used as ⟨list value⟩.

- (O) SHARD s1 VALUES IN ( 1, 1 + 1, 3, 4 )
- (O) SHARD s2 VALUES IN ( 5, 6, 7, NULL )
- (O) SHARD s3 VALUES IN ( DEFAULT )
- (X) SHARD s4 VALUES IN ( DEFAULT, 8, 9, 10 )
- (X) SHARD s5 VALUES IN ( current\_timestamp, systimestamp )
- (X) SHARD s6 VALUES IN ( c1, c2 )

## ⟨table physical attribute clause⟩

It defines the physical attribute information of the table.

- PCTFREE integer
  - Definition
    - The reserved space in case the row size is increased when altering or updating a row in a page.
    - The initial input is input in other space except for this reserved space.
    - If PCTFREE is not enough ROW MIGRATION occurs when altering or updating the data.



- It can use of the value from 0 to 99.
- If it is omitted, the default value is 10.
- PCTUSED integer
  - Definition
    - It is the minimum percentage which can be used for the row data and overhead before adding a new row to a page.
    - It can be input only on this page when the value got smaller than PCTUSED due to alteration or deletion of the existing data.
  - It can use of the value from 0 to 99.
  - If it is omitted, the default value is 40.
- INITRANS integer
  - Definition
    - It specifies the initial number of transactions which can simultaneously access the page.
    - If the number of users who access the index is small, INITRANS is set to low, and if the number of users who simultaneously access the index is big, INITRANS is set to high.
    - If necessary, it is automatically increased to the specified MAXTRANS.
  - It can use the value from 1 to 32.
  - If it is omitted, the default value is 4.
- MAXTRANS integer
  - Definition
    - It specifies the maximum number of transactions which can simultaneously access the page.
  - It can use the value from 1 to 32.
  - If it is omitted, the default value is 8.

## ⟨index physical attribute clause⟩

It defines the physical attributes of the index.

- PCTFREE integer
  - Definition
    - It is a reserved space for adjusting the frequency of page splits caused by the key insertion in the page.
    - It is applied only to the index bottom-up build.
  - It can use the value from 0 to 99.
  - If it is omitted, the value set in DEFAULT\_INDEX\_PCTFREE property is used.
- INITRANS integer
  - It is as same as INITRANS in ⟨table physical attribute clause⟩.
- MAXTRANS integer
  - It is as same as MAXTRANS in ⟨table physical attribute clause⟩.

## <segment attr clause>

It describes the information about the space in which the table is stored.

- INITIAL integer
  - Definition
    - It specifies the size of physical storage space which is initially allocated when creating the table.
    - The size is aligned to the EXTENT size of TABLESPACE to which the table belongs. (e.g. If the EXT size is 8192 bytes, 'INITIAL 100' actually operates as 8192 bytes.)
    - The size (aligned to the size of TABLESPACE EXTENT) should be equal to or bigger than the size of MINEXTENTS, and it should be equal to or smaller than the size of the MAXEXTENTS.
  - The minimum value is 1, and the maximum value depends on the system environment.
  - If it is omitted, the default value is a single EXTENT size of TABLESPACE where the table belongs.
- NEXT integer
  - Definition
    - It specifies the physical space size to be allocated when adding the space to the table.
    - The size is aligned to EXTENT size of TABLESPACE to which the table belongs. (e.g. If the EXT size is 8192 bytes, 'INITIAL 100' actually operates as 8192 bytes.)
    - NEXT is operated as follows according to the size of the remaining space of the currently available table. (The size of subtracting the currently used space from the size of MAXEXTENTS.)
      - If the remaining space size is 0, then it can not extend the space.
      - If the remaining space size is bigger than 0, but smaller than NEXT, then it allocates the space as big as the remaining space.
      - If the remaining space size is bigger than NEXT, then it allocates the space as big as the NEXT.
  - The minimum value is 1, and the maximum value depends on the system environment.
  - If it is omitted, the default value is a single EXTENT size of TABLESPACE to which the table belongs.
- MINSIZE integer
  - Definition
    - It is the minimum space size which the table should maintain.
    - It should be equal to or smaller than the value of MAXSIZE.
  - It is aligned to the EXTENT size of TABLESPACE to which the table belongs.
  - The minimum value is 1, and the maximum value depends on the system environment.
  - If it is smaller than the size of two EXTENTs, the size of two EXTENTs is allocated.
  - If it is omitted, the default value is the size of two EXTENTs.
- MAXSIZE integer
  - Definition
    - It is the maximum space size which can be allocated to a table.
    - It should be equal to or bigger than the value of MINSIZE.

- This size is aligned to the EXTENT size of TABLESPACE to which the table belongs.
- The minimum value is 1, and the maximum value depends on the system environment.
- If it is omitted, the default value is EXTENT size \* 2147483647 (The maximum positive integer of INT32).

## ⟨size clause⟩

It specifies the file size in bytes. (If it is omitted, the default unit is bytes.)

- K: Kilobytes
- M: Megabytes
- G: Gigabytes
- T: Terabytes

## TABLESPACE tablespace\_name

It specifies the tablespace name in which a table is to be stored.

If TABLESPACE clause is omitted, the default tablespace\_name of the user performing the statement is used.

## TABLESPACE index\_tablespace\_name

It specifies the tablespace name in which an index is to be stored.

If TABLESPACE clause is omitted, then it uses the index tablespace of the user.

If the index tablespace of the user is NULL, then the DISK table uses the user's data tablespace and the MEMORY table uses the user's default temporary tablespace.

## ⟨constraint characteristics⟩

It defines characteristics of the constraint.

When defining constraints, the following characteristics can be set.

- DEFERRABLE | NOT DEFERRABLE
- ⟨constraint check time⟩

If ⟨constraint characteristics⟩ is omitted, it is set to NOT DEFERRABLE INITIALLY IMMEDIATE.

## DEFERRABLE | NOT DEFERRABLE

It sets whether the constraints checking is deferrable so that the constraints can be checked when executing COMMIT without checking when executing DML statements.

The checking time of the deferrable constraint is controlled by **SET CONSTRAINTS**.

- NOT DEFERRABLE
  - The checking point is not deferrable, and the constraints are checked when executing INSERT/DELETE/UPDATE statements.
- DEFERRABLE
  - The checking point can be controlled by **SET CONSTRAINTS** statement.
  - SET CONSTRAINTS constraint\_name IMMEDIATE
    - The constraint is checked when executing DML statement.
  - SET CONSTRAINTS constraint\_name DEFERRED
    - The constraint is checked when executing COMMIT statement.
- If not specified, the default value is determined in accordance with the <constraint check time>.
  - If INITIALLY IMMEDIATE is specified, the constraint check time is NOT DEFERRABLE.
  - If INITIALLY DEFERRED is specified, the constraint check time is DEFERRABLE.
  - If <constraint check time> is not specified, the constraint check time is NOT DEFERRABLE.

### <constraint check time>

If the constraints are DEFERRABLE, it sets an initial value for the checking time.

- INITIALLY IMMEDIATE
  - The constraint is checked when executing the DML statements.
- INITIALLY DEFERRED
  - The constraint is checked when executing the COMMIT statements.
  - It can not be used together with NOT DEFERRABLE.
- If not specified, the default value is INITIALLY IMMEDIATE.

For more information about the deferrable constraints, refer to **SET CONSTRAINTS**.

### <table global secondary index clause>

It defines a global secondary index of the table.

- WITH GLOBAL SECONDARY INDEX [ <index attributes> [...] ] [ TABLESPACE tablespace\_name ]
  - It creates a global secondary index when creating a table in a cluster system environment.
  - <index attribute>
    - It sets an index attribute of a global secondary index.
  - TABLESPACE tablespace\_name

- It specifies a tablespace to create a global secondary index.
- WITHOUT GLOBAL SECONDARY INDEX
  - It does not create a global secondary index when creating a table in a cluster system environment.

## Description

### Constraint Characteristics

GOLDILOCKS automatically creates an index to check the uniqueness when generating key constraints.

The following columns do not allow NULL value.

- A column including NOT NULL constraint
- A column which is included in primary key constraints
- An identity column

### Cluster Table

A table manages data using one of the following sharding strategies in a cluster environment.

- Cloned table
  - It duplicates all table data and place them in a cluster system.
- Hash sharded table
  - It divides the table data into several shards based on the hash value of a sharding key, then places them in the cluster system.
- Range sharded table
  - It divides the table data into several shards based on the range value of a sharding key, then places them in the cluster system.
- List sharded table
  - It divides the table data into several shards based on the list value of a sharding key, then places them in the cluster system.

The sharding strategy is determined considering the followings when creating a table. Tables operated in a cluster system are specified as a code table and a fact table based on its features.

- Code table
  - It is a table such as a product list or a provider list whose data is relatively small and is not often altered
  - This table is referenced often together with a fact table.
- Fact table
  - It is a table such as a transaction history or a call history whose data is relatively big and is often altered.

- Its data is big so required to be sharded.

⟨cloned strategy⟩ is appropriate for a code table, and an appropriate ⟨table sharding strategy⟩ should be determined according to the table access pattern in case of a fact table.

## Examples

The following is an example of generating an ordinary table.

```
gSQL> CREATE TABLE region
(
  r_regionkey  INTEGER
, r_name      CHAR(25)
, r_comment   VARCHAR(152)
);
```

Table created.

The following is an example of specifying the constraints on the columns when creating a table.

```
gSQL> CREATE TABLE supplier
(
  s_suppkey    INTEGER PRIMARY KEY
, s_name      CHAR(25) NOT NULL
, s_address   VARCHAR(40)
, s_nationkey  INTEGER
, s_phone     CHAR(15)
, s_acctbal   NUMERIC(12,2)
, s_comment   VARCHAR(101)
);
```

Table created.

The following is an example of specifying the constraint which includes multiple columns when creating a table.

```
gSQL> CREATE TABLE partsupp
(
  ps_partkey   INTEGER
, ps_suppkey   INTEGER
, ps_availqty  INTEGER
, ps_supplycost NUMERIC(12,2)
```

```
, ps_comment    VARCHAR(199)
, CONSTRAINT ps_unique_key UNIQUE(ps_partkey, ps_suppkey)
);
Table created.
```

The following is an example of specifying whether constraints are deferrable when creating a table.

```
gSQL> CREATE TABLE t1
(
  id      NUMBER          PRIMARY KEY
                                NOT DEFERRABLE INITIALLY IMMEDIATE
, name   VARCHAR(128)    CONSTRAINT t1_nn NOT NULL
                                DEFERRABLE INITIALLY IMMEDIATE
, addr   VARCHAR(1024)
, CONSTRAINT t1_uk UNIQUE ( id, name )
                                DEFERRABLE INITIALLY DEFERRED
);
Table created.
gSQL> COMMIT;
Commit complete.
```

The following is an example of specifying a column including automatically generated values and the default value when creating a table.

```
CREATE TABLE customer
(
  c_custkey    INTEGER    GENERATED BY DEFAULT AS IDENTITY
, c_name      VARCHAR(25)
, c_address   VARCHAR(40) DEFAULT 'N/A'
, c_nationkey INTEGER
, c_phone     CHAR(15)
, c_acctbal   NUMERIC(12,2)
, c_mktsegment CHAR(10)
, c_comment   VARCHAR(117)
);
Table created.
```

The following is an example of specifying the tablespace which is to be stored when creating a table.

```
gSQL> CREATE TABLE lineitem
(
  l_orderkey   INTEGER
```

```

, l_partkey      INTEGER
, l_supkey       INTEGER
, l_linenumber   INTEGER
, l_quantity     NUMERIC(12,2)
, l_extendedprice NUMERIC(12,2)
, l_discount     NUMERIC(12,2)
, l_tax          NUMERIC(12,2)
, l_returnflag   CHAR(1)
, l_linestatus   CHAR(1)
, l_shipdate     DATE
, l_commitdate   DATE
, l_receiptdate  DATE
, l_shipinstruct CHAR(25)
, l_shipmode     CHAR(10)
, l_comment      VARCHAR(44)
, PRIMARY KEY (l_orderkey, l_linenumber) INDEX lineitem_pk_idx TABLESPACE mem_temp_tbs
) TABLESPACE mem_data_tbs;
Table created.

```

The following is an example of defining a cluster-wide cloned table. The table data is copied and placed all over the cluster system.

```

gSQL>
CREATE TABLE region
(
    r_regionkey  INTEGER
, r_name       CHAR(25)
, r_comment    VARCHAR(152)
)
CLONED
AT CLUSTER WIDE
;
Table created.

```

The following is an example of defining a group-specific cloned table. The table data is copied and placed in a cluster group g1 and g2 specified by a user.

```

gSQL>
CREATE TABLE region
(
    r_regionkey  INTEGER
, r_name       CHAR(25)

```



```

, r_comment    VARCHAR(152)
)
CLONED
AT CLUSTER GROUP g1, g2
;
Table created.

```

The following is an example of defining a cluster-wide hash sharded table. The table data is divided into 24 shards based on the hash value of a `ps_partkey` column, and each shard is automatically placed all over the cluster system.

```

gSQL>
CREATE TABLE partsupp
(
    ps_partkey    INTEGER
, ps_suppkey    INTEGER
, ps_availqty   INTEGER
, ps_supplycost NUMERIC(12,2)
, ps_comment    VARCHAR(199)
)
SHARDING BY HASH ( ps_partkey )
SHARD COUNT 24
AT CLUSTER WIDE
;
Table created.

```

The following is an example of defining a group-specific hash sharded table. The table data is divided into 24 shards based on the hash value of a `ps_partkey` column, and each shard is automatically placed in a specified cluster group `g2` and `g3`.

```

gSQL>
CREATE TABLE partsupp
(
    ps_partkey    INTEGER
, ps_suppkey    INTEGER
, ps_availqty   INTEGER
, ps_supplycost NUMERIC(12,2)
, ps_comment    VARCHAR(199)
)
SHARDING BY HASH ( ps_partkey )
SHARD COUNT 24
AT CLUSTER GROUP g2, g3

```

;

Table created.

The following is an example of defining a cluster-wide range sharded table. The table data is divided into 24 shards based on the range value of D\_ID column, and each shard is automatically placed all over the cluster system.

gSQL&gt;

```
CREATE TABLE DISTRICT (
  D_ID      INTEGER,
  D_W_ID    INTEGER,
  D_NAME    VARCHAR(10),
  D_STREET_1 VARCHAR(20),
  D_STREET_2 VARCHAR(20),
  D_CITY    VARCHAR(20),
  D_STATE   CHAR(2),
  D_ZIP     CHAR(9),
  D_TAX     NUMERIC(4,4),
  D_YTD     NUMERIC(15,2),
  D_NEXT_O_ID INTEGER,
  PRIMARY KEY (D_W_ID, D_ID) INDEX DISTRICT_PK_IDX
)
SHARDING BY RANGE (D_ID)
AT CLUSTER WIDE
SHARD s1 VALUES LESS THAN ( 100 ),
SHARD s2 VALUES LESS THAN ( 200 ),
SHARD s3 VALUES LESS THAN ( 300 ),
SHARD s4 VALUES LESS THAN ( 400 ),
SHARD s5 VALUES LESS THAN ( 500 ),
SHARD s6 VALUES LESS THAN ( 600 ),
SHARD s7 VALUES LESS THAN ( 700 ),
SHARD s8 VALUES LESS THAN ( MAXVALUE );
;
```

Table created.

The following is an example of defining a group-specific range sharded table. The table data is divided into three range values based on the range value of a NO\_D\_ID column, and a shard s1 is placed in a cluster group g1, a shard s2 is placed in a cluster group g2, a shard s3 is placed in a cluster group g3.

gSQL&gt;

```
CREATE TABLE NEW_ORDER
(
```

```

NO_O_ID INTEGER,
NO_D_ID INTEGER,
NO_W_ID INTEGER,
PRIMARY KEY(NO_W_ID, NO_D_ID, NO_O_ID) INDEX NEW_ORDER_PK_IDX
)
SHARDING BY RANGE (NO_D_ID)
SHARD s1 VALUES LESS THAN ( 5 )          AT CLUSTER GROUP g1,
SHARD s2 VALUES LESS THAN ( 8 )          AT CLUSTER GROUP g2,
SHARD s3 VALUES LESS THAN ( MAXVALUE ) AT CLUSTER GROUP g3
;

```

Table created.

The following is an example of defining a cluster-wide list sharded table. A list shard is divided into five based on a city column, and each shard is automatically placed all over the cluster system.

```

gSQL>
CREATE TABLE t1
(
  id   INTEGER
, name VARCHAR(32)
, city VARCHAR(128)
)
SHARDING BY LIST (city)
  AT CLUSTER WIDE
  SHARD s1 VALUES IN ( 'seoul' ),
  SHARD s2 VALUES IN ( 'busan', 'ulsan' ),
  SHARD s3 VALUES IN ( 'suwon', 'ansan', 'osan' ),
  SHARD s4 VALUES IN ( 'goyang', 'paju', 'guri' ),
  SHARD s5 VALUES IN ( DEFAULT )
;

```

Table created.

The following is an example of defining a group-specific list sharded table. A list shard is divided into five based on a city column, and each shard is placed in a specified cluster group.

```

gSQL>
CREATE TABLE t1
(
  id   INTEGER
, name VARCHAR(32)
, city VARCHAR(128)
)

```

```

SHARDING BY LIST (city)
  SHARD s1 VALUES IN ( 'seoul' )           AT CLUSTER GROUP g1,
  SHARD s2 VALUES IN ( 'busan', 'ulsan' )  AT CLUSTER GROUP g2,
  SHARD s3 VALUES IN ( 'suwon', 'ansan', 'osan' ) AT CLUSTER GROUP g1,
  SHARD s4 VALUES IN ( 'goyang', 'paju', 'guri' ) AT CLUSTER GROUP g2,
  SHARD s5 VALUES IN ( DEFAULT )          AT CLUSTER GROUP g3
;

```

Table created.

A table T1 is created without a global secondary index.

```

gSQL> CREATE TABLE T1 ( I1 INTEGER, I1 CHAR(32) ) WITHOUT GLOBAL SECONDARY INDEX;
Table created.

```

A global secondary index is created after creating a table T1.

```

gSQL> CREATE TABLE T1 ( I1 INTEGER, I1 CHAR(32) ) WITH GLOBAL SECONDARY INDEX;
Table created.

```

A global secondary index of table T1 is created in a tablespace USER\_DATA\_TBS as a logging index after creating a table T1.

```

gSQL> CREATE TABLE T1 ( I1 INTEGER, I1 CHAR(32) )
  WITH GLOBAL SECONDARY INDEX
  TABLESPACE USER_DATA_TBS;
Table created.

```

A global secondary index of table T1 is created in a tablespace USER\_TEMP\_TBS as a nologging index after creating a table T1.

```

gSQL> CREATE TABLE T1 ( I1 INTEGER, I1 CHAR(32) )
  WITH GLOBAL SECONDARY INDEX
  TABLESPACE USER_TEMP_TBS;
Table created.

```

## Compatibility

The SQL standard does not define the following clauses.

- The physical concepts of TABLESPACE clause and <physical attribute clause> clause.
- The SQL standard does not allow an operation in DEFAULT clause.

**Table 19-11** SQL standard compatibility

Feature ID	Description	Compatibility
T171	LIKE clause in table definition	X
F531	Temporary tables	X
S051	Create table of type	X
S043	Enhanced reference types	X
S081	Subtables	X
T173	Extended LIKE clause in table definition	X
T180	System-versioned tables	X
F692	Extended collation support	X
T174	Identity columns	O
T175	Generated columns	X
S071	SQL paths in function and type name resolution	X
F321	User authorization	O
T322	Extended roles	X
F762	CURRENT_CATALOG	O
F763	CURRENT_SCHEMA	O

## For More Information

Refer to the followings.

- DROP TABLE
- ALTER TABLE
- CREATE TABLESPACE
- CREATE SCHEMA
- CREATE INDEX
- CREATE SEQUENCE
- SET CONSTRAINTS
- ALTER TABLE name ADD GLOBAL SECONDARY INDEX

## 19.18 CREATE TABLE AS SELECT

### Function

It creates a new table from the query result.

### Syntax

```

<table definition: AS query expression> ::=
    CREATE TABLE table_name
        [ ( column_name [, ...] ) ]
        [ <table sharding strategy> ]
        [ <table attribute clause> [, ...] ]
        [ TABLESPACE tablespace_name ]
        [ <table global secondary index clause> ]
        AS <query expression> [ WITH [ NO ] DATA ]
    ;

<table sharding strategy> ::=
    <cloned strategy>
    | <hash sharding strategy>
    | <range sharding strategy>
    | <list sharding strategy>

<cloned strategy> ::=
    CLONED [ <clone placement> ]

<clone placement> ::=
    AT CLUSTER WIDE
    | AT CLUSTER GROUP group_list

<hash sharding strategy> ::=
    SHARDING BY [HASH] ( column_list )
    [ <hash shard count> ]
    [ <hash shard placement> ]

<hash shard count> ::=
    SHARD COUNT integer

<hash shard placement> ::=
    AT CLUSTER WIDE
    | AT CLUSTER GROUP group_list

<range sharding strategy> ::=

```

```

SHARDING BY RANGE ( column_list )
  { <cluster-wide range shard placement> | <group-specific range shard placement> }
<cluster-wide range shard placement> ::=
  AT CLUSTER WIDE
  <range shard definition> [, ...]
<group-specific range shard placement> ::=
  <group-specific range shard definition> [, ...]
<group-specific range shard definition> ::=
  <range shard definition> AT CLUSTER GROUP group_name
<range shard definition> ::=
  SHARD range_name VALUES LESS THAN ( <range value clause> )
<range value clause> ::=
  <range value> [, ...]
<range value> ::=
  constant
  | MAXVALUE
<list sharding strategy> ::=
  SHARDING BY LIST ( column_name )
  { <cluster-wide list shard placement> | <group-specific list shard placement> }
<cluster-wide list shard placement> ::=
  AT CLUSTER WIDE
  <list shard definition> [, ...]
<group-specific list shard placement> ::=
  <group-specific list shard definition> [, ...]
<group-specific list shard definition> ::=
  <list shard definition> AT CLUSTER GROUP group_name
<list shard definition> ::=
  SHARD shard_name VALUES IN ( <list value clause> )
<list value clause> ::=
  <list value> [, ...]
<list value> ::=
  constant
  | NULL
  | DEFAULT
<table attribute clause> ::=
  [ <table physical attribute clause> ]
  | [ STORAGE ( <segment attr clause> [...] ) ]
<table physical attribute clause> ::=
  PCTFREE integer
  | PCTUSED integer
  | INITRANS integer

```

```

    | MAXTRANS integer
<index physical attribute clause> ::=
    PCTFREE integer
    | INITTRANS integer
    | MAXTRANS integer
<segment attr clause> ::=
    INITIAL <size_clause>
    | NEXT <size_clause>
    | MINSIZE <size_clause>
    | MAXSIZE <size_clause>
<size clause> ::=
    integer [ K | M | G | T ]
<table global secondary index clause> ::=
    WITH GLOBAL SECONDARY INDEX [ <index attributes> [...] ] [ TABLESPACE tablespace_name ]
    | WITHOUT GLOBAL SECONDARY INDEX

```

## Invocation and Access Rules

A user should satisfy the following conditions to perform <table definition:AS query expression>statement.

- Table creation privilege
  - Refer to the access privilege in **CREATE TABLE**.
- SELECT access privilege
  - Refer to the access privilege in **SELECT**.

## Syntax Rules and Parameters

### table\_name

It is the table name to be created.

For more information, refer to **table\_name**.

### column\_name\_list

It is the name of columns which configure the table, and it should be unique names within the table.

The number of columns should be as same as the number of result columns in SELECT clause.

If not specified, the column names of SELECT clause in <query expression> are used.



However, if there is an expression (function, operation, subquery, etc.) instead of a column in SELECT clause, the alias or column name should be specified.

The length of the column name should be shorter than 128 bytes.

## WITH [NO] DATA

If WITH DATA is specified, the result of SELECT clause is inserted to the table to be created.

If WITH NO DATA is specified, the result of SELECT clause is not inserted to the table to be created.

If not specified, it is operated as same as when WITH DATA is specified.

## Other Syntax

For more information about other syntaxes, refer to the syntax in **CREATE TABLE** statement.

## Description

When executing CREATE TABLE AS SELECT, if a column including a NOT NULL constraint is specified in SELECT list, the NOT NULL constraint is also created in the new table.

However, if the NOT NULL constraint is deferrable, then NOT NULL constraint is not created in the new table.

On the other hand, the NOT NULL constraint is not created in the new table if NOT NULL constraint was not explicitly created but there is NOT NULL property such as primary key column or identity column.

## Examples

The following is an example of executing CREATE TABLE AS SELECT statement.

```
gSQL> CREATE TABLE recent_orders
      AS SELECT order_id, order_item, order_date
      FROM orders
      WHERE order_date >= '2015-03-03'
```

Table created.

The following is an example of specifying the column name.

```
gSQL> CREATE TABLE recent_orders ( order_id, order_item, order_date )
      AS SELECT order_id, order_item, order_date
      FROM orders
      WHERE order_date >= '2015-03-03'
```

Table created.

The following is an example of a function in SELECT list.

```
gSQL> CREATE TABLE recent_orders ( order_date, order_count )
      AS SELECT order_date, COUNT(*)
      FROM orders
      WHERE order_date >= '2015-03-03'
      GROUP BY order_date;
```

Table created.

The following is an example of the statement including WITH DATA.

```
gSQL>CREATE TABLE orders
(
  order_id  NUMBER
, order_item VARCHAR(128)
, order_date DATE
);
gSQL> COMMIT;
gSQL> INSERT INTO orders VALUES ( 1, 'Pen', '2010-01-01' );
gSQL> INSERT INTO orders VALUES ( 2, 'Book', '2015-03-03' );
gSQL> COMMIT;
gSQL> CREATE TABLE recent_orders
      AS SELECT order_id, order_item, order_date
      FROM orders
      WHERE order_date >= '2015-03-03'
```

WITH DATA;

Table created.

```
gSQL> SELECT COUNT(*) FROM recent_orders;
```

```
COUNT(*)
```

```
-----
```

```
1
```

1 row selected.

The following is an example of the statement including WITH NO DATA.

```

gSQL>CREATE TABLE orders
(
  order_id  NUMBER
, order_item VARCHAR(128)
, order_date DATE
);
gSQL> COMMIT;
gSQL> INSERT INTO orders VALUES ( 1, 'Pen', '2010-01-01' );
gSQL> INSERT INTO orders VALUES ( 2, 'Book', '2015-03-03' );
gSQL> COMMIT;
gSQL> CREATE TABLE recent_orders
          AS SELECT order_id, order_item, order_date
          FROM orders
          WHERE order_date >= '2015-03-03'
          WITH NO DATA;
Table created.
gSQL> SELECT COUNT(*) FROM recent_orders;
COUNT(*)
-----
          0
1 row selected.

```

## Compatibility

CREATE TABLE AS SELECT statement follows SQL standard. However, the following is an extension of SQL standard.

- SQL standard require parentheses outside SELECT clause, but it is optional in GOLDDILOCKS.
- SQL standard require WITH [NO] DATA clause, but it is optional in GOLDDILOCKS.
- The concepts of tablespace in GOLDDILOCKS is an extended concept, and it is not supported in SQL standard.

**Table 19-12** SQL standard compatibility

Feature ID	Description	Compatibility
T172	AS subquery clause in table definition	O

## For More Information

Refer to the followings.

- [CREATE TABLE](#)
- [SELECT](#)

## 19.19 CREATE TABLESPACE

### Function

It creates a tablespace.

### Syntax

```
<create tablespace statement> ::=  
    <memory data tablespace statement>  
    | <memory temporary tablespace statement>  
    ;
```

### Invocation and Access Rules

CREATE TABLESPACE ON DATABASE privilege is required to perform <create tablespace statement>.

The user who performed the statement has CREATE OBJECT ON TABLESPACE privilege on the created tablespace.

One of the following privileges are required to create the objects on the created tablespace.

- CREATE OBJECT ON TABLESPACE for that tablespace
- USAGE TABLESPACE ON DATABASE

### Syntax Rules and Parameters

#### <memory data tablespace statement>

- [ MEMORY ] TEMPORARY

It is a memory temporary tablespace to store the no logging indexes or the temporary objects such as intermediate results which are generated during the query processing.

The reserved word MEMORY can be omitted.

## ⟨memory data tablespace clause⟩

It defines a memory data tablespace.

For more information, refer to `CREATE MEMORY DATA TABLESPACE`.

## ⟨memory temporary tablespace definition⟩

It defines a memory temporary tablespace.

For more information, refer to `CREATE MEMORY TEMPORARY TABLESPACE`.

## Description

For more information, refer to the description of each detailed statement.

## Example

For more information, refer to usage example of each detailed statement.

## Compatibility

The SQL standard does not cover the concepts of the tablespace.

## For More Information

Refer to the followings.

- `DROP TABLESPACE`
- `ALTER TABLESPACE`

## 19.20 CREATE USER

### Function

It defines a database user.

### Syntax

```
<user definition> ::=  
    CREATE USER user_identifier IDENTIFIED BY password  
    [ PROFILE { profile_name | DEFAULT | NULL } ]  
    [ PASSWORD EXPIRE ]  
    [ ACCOUNT { LOCK | UNLOCK } ]  
    [ DEFAULT TABLESPACE tablespace_name ]  
    [ TEMPORARY TABLESPACE tablespace_name ]  
    [ INDEX TABLESPACE { tablespace_name | NULL } ]  
    [ <schema clause> ]  
    ;  
  
<schema clause> ::=  
    WITH SCHEMA [ schema_name ]  
    | WITHOUT SCHEMA
```

### Invocation and Access Rules

CREATE USER ON DATABASE privilege is required to perform <user definition>.

The created user, user\_identifier, has the privilege, which is the owner the schema created by using <schema clause>.



A separate privilege is not granted to the created user\_identifier.

The appropriate privileges should be granted to user\_identifier to access and perform SQL statements.

## Syntax Rules and Parameters

### **user\_identifier**

It is the username to be created.

The identical username (user identifier) or role (role name) should not exist.

The length of user\_identifier should be shorter than 128 bytes.

### **password**

It is the user's password to be created. It is encrypted and stored.

The length of password should be shorter than 128 bytes.

The password is case sensitive.

The password should start with an alphabetic character, and it can include alphabetic characters, numbers, underscore (\_), and \$.

The other special characters should be enclosed in double quotes ("").

### **PROFILE { profile\_name | DEFAULT | NULL }**

The profile for password management policy is assigned.

- PROFILE profile\_name
  - It allocates the profile\_name which is created by a user.
- PROFILE DEFAULT
  - It allocates the default profile "DEFAULT".
- PROFILE NULL
  - It does not allocate the profile.

If PROFILE clause is omitted, it is as same as PROFILE NULL, and the profile is not applied.

For more information about the password management policy, refer to **CREATE PROFILE**.

### **PASSWORD EXPIRE**

It expires the user's password.

It is used when a user attempts to change the password by force before login.



## ACCOUNT { LOCK | UNLOCK }

- ACCOUNT LOCK
  - It locks the user account.
- ACCOUNT UNLOCK
  - It unlocks the user account.

## DEFAULT TABLESPACE `tablespace_name`

It specifies the default TABLESPACE to store objects such as the table created by the user, the indexes (with NOLOGGING option).

If DEFAULT TABLESPACE clause is omitted, default data tablespace(MEM\_DATA\_TBS) is specified, which was defined when creating DATABASE.

## TEMPORARY TABLESPACE `tablespace_name`

It specifies the TABLESPACE which stores the temporary tables created by a user, indexes (NO LOGGING), and the intermediate results generated by the query processing.

If TEMPORARY TABLESPACE clause is omitted, default temporary tablespace (MEM\_TEMP\_TBS) is specified, which was defined when creating DATABASE.

## INDEX TABLESPACE { `tablespace_name` | NULL }

It specifies the default TABLESPACE which stores the index objects created by a user.

- Specifying INDEX TABLESPACE `tablespace_name`
  - If it specifies the data tablespace, then it becomes the LOGGING index.
  - If it specifies the temporary tablespace, then it becomes the NOLOGGING index.
- INDEX TABLESPACE NULL
  - It does not specify the index tablespace.

If INDEX TABLESPACE clause is omitted, then it is INDEX TABLESPACE NULL.

## ⟨`schema clause`⟩

It creates a schema which a user uses by default.

The schema name should be unique in the database.

- WITH SCHEMA [`schema_name`]
  - If `schema_name` is not assigned, the schema is created whose name is as same as `user_identifier`.

- SCHEMA PATH of the user is set as follows.
  - schema\_name, PUBLIC
- WITHOUT SCHEMA
  - It does not create the schema which is to be owned by a user.
  - SCHEMA PATH of the user is set as PUBLIC.

If <schema clause> is not specified, the default value is WITH SCHEMA and the schema is created whose name is as same as user\_identifier.

The schema to be owned by the user can be additionally created by using **CREATE SCHEMA** statement.

## Description

A user is an authorization object which consists of a set of privileges.

When <user definition> statement is executed for the first time, a user without any privilege is created, and the appropriate privileges should be granted as follows.

In GOLDILOCKS, the relationship between user and schema is 1 : N.

In other words, a user does not own any schema, or a user can own multiple schemas.

The SQL standard does not explicitly define the relationship of the non-schema objects such as a user, a schema, or a database. Each DBMS defines the relationship of non-schema objects in different concept as follows.



The relationship between user and schema in other DBMS.

- Oracle
  - User : schema = 1 : 1.
- DB2
  - It is as same as the OS user.
  - The separate SQL statements which creates or deletes a user do not exist.
- Postgres
  - User : schema = 1 : N.

- MySQL
  - Database : schema = 1 : 1.
  - User is a subordinate object of database (schema).

## Examples

At least the following privileges should be granted to create a user, and for the created user to create the objects, manipulate data.

The following is an example of creating a user and granting privileges.

- Create a user.

```
gSQL> CREATE USER u1 IDENTIFIED BY u1_password
        DEFAULT TABLESPACE mem_data_tbs
        TEMPORARY TABLESPACE mem_temp_tbs
        INDEX TABLESPACE NULL;
```

User created.

```
gSQL> COMMIT;
```

Commit complete.

- Grant database privileges.

```
gSQL> GRANT CREATE SESSION ON DATABASE TO u1;
```

Grant succeeded.

```
COMMIT;
```

Commit complete.

- Grant schema privileges.

```
GRANT CREATE TABLE, CREATE VIEW, CREATE INDEX, CREATE SEQUENCE, ADD CONSTRAINT
        ON SCHEMA u1 TO u1;
```

Grant succeeded.

```
COMMIT;
```

Commit complete.

- Grant tablespace privileges.

```
GRANT CREATE OBJECT ON TABLESPACE mem_data_tbs TO u1;
```

Grant succeeded.

```
GRANT CREATE OBJECT ON TABLESPACE mem_temp_tbs TO u1;
Grant succeeded.
COMMIT;
Commit complete.
```

The following is an example of creating objects by the user.

- It needs CREATE SESSION ON DATABASE.

```
gSQL> \connect u1 u1_password
```

- It needs CREATE TABLE ON SCHEMA u1.
- It needs CREATE OBJECT ON TABLESPACE mem\_data\_tbs.

```
gSQL> CREATE TABLE u1.t1 ( c1 INTEGER, c2 INTEGER ) TABLESPACE mem_data_tbs;
Table created.
gSQL> COMMIT;
```

- It needs CREATE INDEX ON SCHEMA u1.
- It needs CREATE OBJECT ON TABLESPACE mem\_temp\_tbs.

```
gSQL> CREATE INDEX u1.idx ON t1 (c2) TABLESPACE mem_temp_tbs;
Index created.
gSQL> COMMIT;
```

- It needs ADD CONSTRAINT ON SCHEMA u1.

```
gSQL> ALTER TABLE t1 ADD CONSTRAINT u1.t1_pk PRIMARY KEY (c1) ;
Table altered.
gSQL> COMMIT;
```

- It needs CREATE SEQUENCE ON SCHEMA u1.

```
gSQL> CREATE SEQUENCE u1.seq;
Sequence created.
gSQL> COMMIT;
gSQL> INSERT INTO u1.t1 VALUES ( u1.seq.NEXTVAL, u1.seq.NEXTVAL );
1 row created
gSQL> COMMIT;
```

## Compatibility

The SQL standard covers the concepts of the user, but it does not define the SQL statements associated with the creation and deletion of user.

## For More Information

Refer to the followings.

- [DROP USER](#)
- [ALTER USER](#)
- [CREATE SCHEMA](#)

## 19.21 CREATE VIEW

### Function

It defines a view.

### Syntax

```
<view definition> ::=  
    CREATE [ OR REPLACE ] [ FORCE | NO FORCE ]  
        VIEW view_name [ ( column_name [, ...] ) ]  
        AS <query expression>  
    ;
```

### Invocation and Access Rules

The user should satisfy the following conditions to perform <view definition> statement.

- One of the following privileges is required to create a view.
  - (CREATE VIEW or CONTROL SCHEMA) ON SCHEMA for the schema to which the view belongs
  - CREATE ANY VIEW ON DATABASE
- When using OR REPLACE clause, if a view already exists, then one of the following privileges is required to remove the existing view.
  - The owner of that view
  - CONTROL TABLE ON TABLE for that view.
  - (DROP VIEW or CONTROL SCHEMA) ON SCHEMA for the schema to which the view belongs
  - DROP ANY VIEW ON DATABASE
- One of the following privileges is required for all tables used in <Query expression>.
  - SELECT(columns) ON TABLE for all columns used in the statement among table columns
  - (SELECT or CONTROL TABLE) ON TABLE for the table
  - (SELECT TABLE or CONTROL SCHEMA) ON SCHEMA for the schema to which the table belongs
  - SELECT ANY TABLE ON DATABASE
- The owner of the created view is determined as follows.

- The owner of the schema to which the view belongs.
- If the schema to which the view belongs is PUBLIC, then it is the user who executed the statement.
- The owner of the view has the following privileges for the created view.
  - SELECT ON TABLE WITH GRANT OPTION
  - INSERT ON TABLE WITH GRANT OPTION
  - UPDATE ON TABLE WITH GRANT OPTION
  - DELETE ON TABLE WITH GRANT OPTION
  - TRIGGER ON TABLE
  - LOCK ON TABLE WITH GRANT OPTION
  - ALTER ON TABLE WITH GRANT OPTION

## Syntax Rules and Parameters

### [ OR REPLACE ]

It replaces the existing view when a view already exists.

### [ FORCE | NO FORCE ]

- FORCE
  - A view is created regardless of the validity of <query expression>.
- NO FORCE
  - A view is created when <Query expression> is valid.
- The default value is NO FORCE.

### view\_name

It is the view name to be created, and it should be a unique name within the schema.

The schema to which the view belongs, such as schema\_name.view\_name, can be defined. If schema\_name is omitted, the default schema name of the user performing the statement is used.

The length of the view name must be shorter than 128 bytes.

### [ ( column\_name [, ...] ) ]

It defines a column name which will configure the view.

Each column name should be unique within the view.

The number of columns should be as same as the number of result columns in SELECT clause.

If the list of column names is omitted, the column names of SELECT clause in <query expression> are used.

## AS <query expression>

It is the SELECT query which will create a view.

<query expression> can not include the following variables.

- Host parameter
- SQL parameter
- Dynamic parameter
- Embedded variable
- SEQUENCE object

## Description

A view is the object which gave a name to the query, and it is used in the similar way of a table.

When executing a query including the view, that view is interpreted as the query included in the view definition. If the table referenced by the view is altered, as the following example, the asterisk (\*) included in the view definition is automatically interpreted based on the altered table information.

```
gSQL> CREATE VIEW v1 AS SELECT * FROM t1;
gSQL> COMMIT;
gSQL> SELECT * FROM v1;
ID NAME
-- -----
 1 leekmo
 2 mkkim
 3 egospace
3 rows selected.
gSQL> ALTER TABLE t1 ADD COLUMN ( dept_id INTEGER, addr VARCHAR(1024) );
gSQL> COMMIT;
gSQL> select * from v1;
ID NAME      DEPT_ID ADDR
-- -----
 1 leekmo      null null
 2 mkkim       null null
 3 egospace    null null
```



3 rows selected.

The view is affected if the view is created on the query including errors by using FORCE option, the tables referred by the view, or views are altered or deleted.

This information can be retrieved from INFORMATION\_SCHEMA.VIEWS information.

- IS\_COMPILED column
  - TRUE: The view is normally created.
  - FALSE: The view is created having an error by using FORCE option.
- IS\_AFFECTED column
  - TRUE : The referenced tables by a view or view is altered.
  - FALSE: After a view is created and compiled, the referenced tables or views are not altered.

The maximum number of creating views and the maximum number of columns to be created within a view is not limited. Therefore, they can be created as many as the storage space is available.

## Examples

The following is an example of creating a view.

```
gSQL> CREATE VIEW v1 AS SELECT * FROM t1 WHERE dept_id = 101;
View created.
```

The following is an example of defining the column names when defining a view.

```
gSQL> CREATE VIEW v1 ( v_id, v_name )
      AS SELECT id, name FROM t1 WHERE dept_id = 101;
View created.
```

The following is an example of removing the existing view and creating a new view by using REPLACE option.

```
gSQL> CREATE OR REPLACE VIEW v1(id, name)
      AS SELECT id, name FROM t1;
View created.
```

The following is an example of forcing to create a view by using FORCE option even when the referenced object by the view does not exist.

```

gSQL> CREATE FORCE VIEW v1
      AS SELECT * FROM t1 WHERE dept_id = 101;
ERR-01000(16243): Warning: View created with compilation errors
ERR-42000(16040): table or view does not exist :
      AS SELECT * FROM t1 WHERE dept_id = 101
                *
ERROR at line 2:
View created.

```

## Compatibility

The SQL standard does not define the following clauses.

- [ OR REPLACE ] clause
- [ FORCE | NO FORCE ] clause

**Table 19-13** SQL standard compatibility

Feature ID	Description	Compatibility
T131	Recursive query	O
F751	View CHECK enhancements	X
S043	Enhanced reference types	X
T111	Updatable joins, unions, and columns	X
F852	Top-level <order by clause> in views	O
F864	Top-level <result offset clause> in views	O
F859	Top-level <fetch first clause> in views	O
S081	Subtables	X

## For More Information

Refer to the followings.

- **DROP VIEW**
- **ALTER VIEW**
- **SELECT**

## 19.22 DECLARE cursor\_name

### Function

It declares a cursor.

### Syntax

```

<declare cursor> ::=
    DECLARE cursor_name <cursor properties> { FOR | IS } <cursor specification>
    ;
<cursor properties> ::=
    [ <cursor sensitivity> ] [ <cursor scrollability> ] CURSOR [ <cursor holdability> ]
    | [ <odbc cursor type> ] CURSOR [ <cursor holdability> ]
<cursor sensitivity> ::=
    INSENSITIVE
    | SENSITIVE
    | ASENSITIVE
<cursor scrollability> ::=
    NO SCROLL
    | SCROLL
<cursor holdability> ::=
    WITH HOLD
    | WITHOUT HOLD
<odbc cursor type> ::=
    STATIC
    | KEYSET
<cursor specification> ::=
    statement_name
    | <cursor query> [ <updatability clause> ]
<cursor query> ::=
    <select statement>
    | <insert returning query statement>
    | <update returning query statement>
    | <delete returning query statement>
<updatability clause> ::=
    FOR READ ONLY

```

```

| FOR UPDATE [ OF <column name list> ] [ <lock wait mode> ]
<lock wait mode> ::=
| WAIT
| WAIT second
| NOWAIT

```

## Invocation and Access Rules

The dynamic cursor which uses `statement_name` can be used in an embedded SQL.

An appropriate access privilege is required depending on `<cursor query>` types. For more information about the access privileges, refer to the followings.

- The access privilege of a **SELECT** statement
- The access privilege of a **SELECT .. FOR UPDATE** statement
- The access privilege of a **INSERT INTO name RETURNING** statement
- The access privilege of a **UPDATE name RETURNING** statement
- The access privilege of a **DELETE FROM name RETURNING** statement

## Syntax Rules and Parameters

### `cursor_name`

It is the cursor name to be declared.

It should be a unique name within the session.

The length of cursor name should be shorter than 128 bytes.

### { FOR | IS }

Either FOR or IS is used as a syntax keyword in SQL standard.

### <cursor properties>

It defines the cursor properties.

- If `<cursor sensitivity>` is not specified, the default value is **INSENSITIVE**.
- If `<cursor scrollability>` is not specified, the default value is **NO SCROLL**.
- If `<cursor holdability>` is not specified, the default value is determined by `<cursor updatability>`.

## updatable query

To use a cursor property such as SENSITIVE or FOR UPDATE, a query of the cursor should identify changes in rows of the base table, or it should be the updatable query which can acquire a lock on the row.

The updatable query should satisfy all of the following conditions.

- DISTINCT should not exist at the top level query.
  - (X) SELECT DISTINCT \* FROM t1;
- GROUP BY, HAVING, aggregation function should not exist at the top level query.
  - (X) SELECT MAX(c1) FROM t1;
- It should not be a returning query.
  - (X) DELETE FROM t1 RETURNING c1;
- Set operator should not exist.
  - (X) SELECT \* FROM t1 UNION ALL SELECT \* FROM t2;
- At least one updatable column is required on the listed tables in FROM clause.
  - The columns of the tables, which are included in join operations and are not used in the cross join, are not the updatable columns.
    - FULL OUTER JOIN is not cross join.
    - NATURAL JOIN is not cross join.
    - If INNER JOIN uses USING phrase, it is not cross join.
  - The columns of the following tables are not the updatable columns.
    - Dictionary table, fixed table, performance view
  - The columns of the view are not updatable tables.

## <cursor sensitivity>

It determines whether the following data changes which affects the query results can be queried when operating the cursor.

- INSENSITIVE
  - It can not detect the data updated during the cursor operation.
- SENSITIVE
  - <cursor query> should be an updatable query.
  - It detects the updated and deleted data in the transaction as same as that of the cursor.
  - It detects the data updated and deleted through COMMIT of other transactions.
- ASENSITIVE
  - INSENSITIVE or SENSITIVE is determined depending on the type of <cursor query>.
    - For the updatable query, it is SENSITIVE.
    - For no updatable query, it is INSENSITIVE.
- If it is not specified, the default value is INSENSITIVE.

## <cursor scrollability>

It specifies whether the result set of the cursor can be fetched sequentially or non-sequentially.

- NO SCROLL
  - Only sequential FETCH (FETCH NEXT) is possible.
- SCROLL
  - Non-sequential FETCH is possible.
- If not specified, the default value is NO SCROLL.

## <cursor holdability>

It determines whether the cursor is maintained after the cursor is OPEN and the transaction is committed.

- WITH HOLD
  - The cursor is maintained after the transaction is committed.
  - It can not be used together with FOR UPDATE statement.
  - It can not be used together with **INSERT INTO name RETURNING** statement.
  - It can not be used together with **UPDATE name RETURNING** statement.
  - It can not be used together with **DELETE FROM name RETURNING** statement.
  - It can not be used in the query including the global temporary table whose table commit action is ON COMMIT DELETE ROWS.
- WITHOUT HOLD
  - When the transaction is committed or rolled back, the cursor is closed.
- Rollback and cursor
  - It closes a cursor included in a transaction when rolling back the transaction.
  - It closes a cursor created since the savepoint when rolling back up to the savepoint.
- If not specified, the default value of <cursor holdability> is determined by <cursor updatability>.
  - If it is FOR READ ONLY or <cursor updatability> is not specified, the default value is WITH HOLD.
  - If it is used together with FOR UPDATE statement, the default value is WITHOUT HOLD.

## <odbc cursor type>

It is the cursor type in the ODBC standard, and it has the SCROLL property.

- STATIC CURSOR
  - It is as same as INSENSITIVE SCROLL in SQL standard.
  - Non-sequential FETCH is possible.
  - It is the static scroll cursor in the ODBC standard.
- KEYSET CURSOR

- It is as same as ASENSITIVE SCROLL in SQL standard.
- It is the keyset-driven scroll cursor in the ODBC standard.
- The property of sensitivity is determined according to the following characteristics.

**Table 19-14** Sensitivity according to FOR [UPDATE / READ ONLY] statement and the query type

Updatability	Query type	Sensitivity
FOR UPDATE	Updatable query	SENSITIVE
FOR UPDATE	Non-updatable query	Query error
FOR READ ONLY	Any query	INSENSITIVE
N/A	Updatable query	SENSITIVE
N/A	Non-updatable query	INSENSITIVE

## <cursor specification>

It defines a query which is a target of the cursor.

If statement\_name is used, a dynamic cursor whose query has not been defined is declared.

If <cursor query> is used, a standing cursor whose query is defined is declared.

## statement\_name

It is a statement\_name to be referenced by the cursor, and it can be used in an embedded SQL.

statement\_name should exist before performing <declare cursor> statement, and the SQL statement referenced by statement\_name should be the query prepared by PREPARE statement\_name statement.

If it is not a query, an error occurs when executing OPEN cursor\_name statement.

## <cursor query>

For more information about available query types in the cursor, refer to the followings.

- SELECT
- SELECT .. FOR UPDATE
- INSERT INTO name RETURNING
- UPDATE name RETURNING
- DELETE FROM name RETURNING

## <updatability clause>

It specifies whether to change rows by using the cursor.

- FOR READ ONLY
  - It declares a read-only cursor.
- FOR UPDATE
  - It declares a writable cursor.
  - When opening the cursor, the x lock for the corresponding rows is acquired to prevent the change by other transactions until the transaction is completed.
  - It can not be used together with WITH HOLD statement.
  - <cursor query> should be an updatable query.
- If not specified, the default value is FOR READ ONLY.

## FOR UPDATE OF ...

It lists the columns associated with the lock obtaining when OPENing the cursor.

- If it is the columns listed in FOR UPDATE OF statement
  - It should be an updatable column of the table listed in FROM clause of <select statement>.
  - It acquires the lock for the table of listed columns.
- If only FOR UPDATE statement is used
  - It is the same meaning as listing all updatable columns of the table in FROM clause of <select statement>.
  - It acquires the lock for the table of all columns.

## <lock wait mode>

It is used together with FOR UPDATE clause, and it specifies the lock acquisition method.

- WAIT
  - It acquires the lock for all rows of the query result when OPENing the cursor.
  - It waits until acquiring the lock.
- WAIT second
  - It acquires the lock for all rows of the query result when OPENing the cursor.
  - An error occurs if the lock is not acquired within the specified time.
  - The wait time is in seconds, and it can use the value between 0 and 1000000000.
- NOWAIT
  - It acquires the lock for all rows of the query result when OPENing the cursor.
  - An error occurs if the lock is not immediately acquired.
- If not specified, the default value is WAIT.



## Description

When controlling the query property, using DECLARE CURSOR, OPEN, FETCH, CLOSE statements have the performance burden compared to using the cursor with the ODBC or JDBC statements. It is because using DECLARE CURSOR, OPEN, FETCH, CLOSE statements control the cursor of the server.

Before executing the query, the cursor property can be controlled by ODBC statement and JDBC statement. The SQL cursor property control method by DECLARE CURSOR statement, and cursor property control method by the ODBC standard and the JDBC standard are as follows.

**Table 19-15** Controlling the cursor property of ODBC/ JDBC

Property	GOLDILOCKS cursor property	ODBC standard cursor property	JDBC standard cursor property
Sensitivity	INSENSITIVE	SQLSetStmtAttr(stmt, SQL_ATTR_CURSOR_SENSITIVITY, SQL_INSENSITIVE, len)	It can not be set.
	SENSITIVE	SQLSetStmtAttr(stmt, SQL_ATTR_CURSOR_SENSITIVITY, SQL_SENSITIVE, len)	It can not be set.
	ASENSITIVE	SQLSetStmtAttr(stmt, SQL_ATTR_CURSOR_SENSITIVITY, SQL_UNSPECIFIED, len)	It can not be set.
Scrollability	NO SCROLL	SQLSetStmtAttr(stmt, SQL_ATTR_CURSOR_SCROLLABLE, SQL_NONSCROLLABLE, len)	It can not be set.
	SCROLL	SQLSetStmtAttr(stmt, SQL_ATTR_CURSOR_SCROLLABLE, SQL_SCROLLABLE, len)	It can not be set.
Holdability	WITHOUT HOLD	It can not be set.	java.sql.Connection::prepareStatement( query, type, conc, ResultSet.CLOSE_CURSORS_AT_COMMIT )
	WITH HOLD	It can not be set.	java.sql.Connection::prepareStatement( query, type, conc, ResultSet.HOLD_CURSORS_OVER_COMMIT )

SQL cursor declaration corresponding to ODBC cursor type is as follows.

**Table 19-16** SQL cursor declaration corresponding to ODBC cursor type

ODBC cursor type	SQL cursor declaration
SQLSetStmtAttr(stmt, SQL_ATTR_CURSOR_TYPE, SQL_CURSOR_FORWARD_ONLY, len)	NO SCROLL CURSOR

ODBC cursor type	SQL cursor declaration
SQLSetStmtAttr(stmt, SQL_ATTR_CURSOR_TYPE, SQL_CURSOR_STATIC, len)	STATIC CURSOR
SQLSetStmtAttr(stmt, SQL_ATTR_CURSOR_TYPE, SQL_CURSOR_KEYSET_DRIVEN, len )	KEYSET CURSOR

SQL cursor declaration corresponding to JDBC cursor type is as follows.

**Table 19-17** SQL cursor declaration corresponding to JDBC cursor type

JDBC cursor type	SQL cursor declaration
java.sql.Connection::prepareStatement( query, ResultSet.TYPE_FORWARD_ONLY, conc, hold )	INSENSITIVE NO SCROLL CURSOR
java.sql.Connection::prepareStatement( query, ResultSet.TYPE_SCROLL_INSENSITIVE, conc, hold )	INSENSITIVE SCROLL CURSOR
java.sql.Connection::prepareStatement( query, ResultSet.TYPE_SCROLL_SENSITIVE, conc, hold )	KEYSET CURSOR

## Examples

The following is an example of declaring the cursor by using interactive SQL (gsql), and using it.

```
gSQL> DECLARE cur1 CURSOR FOR SELECT id, data FROM t1;
Cursor declared.
gSQL> OPEN cur1;
Cursor is open.
gSQL> \var v_id INTEGER
gSQL> \var v_data VARCHAR(128)
gSQL> FETCH cur1 INTO :v_id, :v_data;
V_ID V_DATA
----
1 data_1
1 row fetched.
gSQL> FETCH cur1 INTO :v_id, :v_data;
V_ID V_DATA
----
2 data_2
1 row fetched.
gSQL> FETCH cur1 INTO :v_id, :v_data;
V_ID V_DATA
----
```

```

    3 data_3
1 row fetched.
gSQL> FETCH cur1 INTO :v_id, :v_data;
V_ID V_DATA
-----
    4 data_4
1 row fetched.
gSQL> FETCH cur1 INTO :v_id, :v_data;
V_ID V_DATA
-----
    5 data_5
1 row fetched.
gSQL> FETCH cur1 INTO :v_id, :v_data;
no rows fetched.
gSQL> CLOSE cur1;
Cursor closed.

```

The following is an example of declaring KEYSET cursor, sequentially searching, then completing the transaction of UPDATE, DELETE statements, and searching for it in the reverse direction.

```

gSQL> DECLARE cur_keyset KEYSET CURSOR FOR SELECT id, data FROM t1;
Cursor declared.
gSQL> OPEN cur_keyset;
Cursor is open.
gSQL> \var v_id    INTEGER
gSQL> \var v_data VARCHAR(128)
gSQL> FETCH NEXT cur_keyset INTO :v_id, :v_data;
V_ID V_DATA
-----
    1 data_1
1 row fetched.
gSQL> FETCH NEXT cur_keyset INTO :v_id, :v_data;
V_ID V_DATA
-----
    2 data_2
1 row fetched.
gSQL> FETCH NEXT cur_keyset INTO :v_id, :v_data;
V_ID V_DATA
-----
    3 data_3
1 row fetched.

```

```
gSQL> FETCH NEXT cur_keyset INTO :v_id, :v_data;
V_ID V_DATA
----
      4 data_4
1 row fetched.
gSQL> FETCH NEXT cur_keyset INTO :v_id, :v_data;
V_ID V_DATA
----
      5 data_5
1 row fetched.
gSQL> FETCH NEXT cur_keyset INTO :v_id, :v_data;
no rows fetched.
gSQL> UPDATE t1 SET data = 'new data_2' WHERE id = 2;
1 row updated.
gSQL> COMMIT;
Commit complete.
gSQL> DELETE FROM t1 WHERE id = 4;
1 row deleted.
gSQL> COMMIT;
Commit complete.
gSQL> FETCH PRIOR cur_keyset INTO :v_id, :v_data;
V_ID V_DATA
----
      5 data_5
1 row fetched.
gSQL> FETCH PRIOR cur_keyset INTO :v_id, :v_data;
no rows fetched.
gSQL> FETCH PRIOR cur_keyset INTO :v_id, :v_data;
V_ID V_DATA
----
      3 data_3
1 row fetched.
gSQL> FETCH PRIOR cur_keyset INTO :v_id, :v_data;
V_ID V_DATA
----
      2 new data_2
1 row fetched.
gSQL> FETCH PRIOR cur_keyset INTO :v_id, :v_data;
V_ID V_DATA
----
      1 data_1
```

```

1 row fetched.
gSQL> CLOSE cur_keyset;
Cursor closed.

```

The following is an example of declaring SCROLL cursor, and using the cursor through the fetch orientation.

```

gSQL> DECLARE cur_scroll SCROLL CURSOR FOR SELECT id, data FROM t1;
Cursor declared.
gSQL> OPEN cur_scroll;
Cursor is open.
gSQL> \var v_id  INTEGER
gSQL> \var v_data VARCHAR(128)
gSQL> FETCH LAST cur_scroll INTO :v_id, :v_data;
V_ID V_DATA
----
      5 data_5
1 row fetched.
gSQL> FETCH PRIOR cur_scroll INTO :v_id, :v_data;
V_ID V_DATA
----
      4 data_4
1 row fetched.
gSQL> FETCH FIRST cur_scroll INTO :v_id, :v_data;
V_ID V_DATA
----
      1 data_1
1 row fetched.
gSQL> FETCH ABSOLUTE 3 cur_scroll INTO :v_id, :v_data;
V_ID V_DATA
----
      3 data_3
1 row fetched.
gSQL> FETCH RELATIVE -1 cur_scroll INTO :v_id, :v_data;
V_ID V_DATA
----
      2 data_2
1 row fetched.
gSQL> FETCH ABSOLUTE 3 cur_scroll INTO :v_id, :v_data;
V_ID V_DATA
----

```

```

3 data_3
1 row fetched.
gSQL> CLOSE cur_scroll;
Cursor closed.

```

## Compatibility

<declare cursor> statement has the following differences compared to the SQL standard.

- In SQL standard, the default value of <cursor sensitivity> is ASENSITIVE, but in GOLDILOCKS, the default value is INSENSITIVE.
- The SQL standard does not cover the following <odbc cursor type>.
  - STATIC CURSOR
  - KEYSSET CURSOR
- In SQL standard, the default value of <cursor holdability> is WITHOUT HOLD, but in GOLDILOCKS, the default value depends on <cursor updatability>.
- SQL standard can use only <select statement> as <cursor query>, but GOLDILOCKS can use the returning query as follows.
  - **INSERT INTO name RETURNING**
  - **UPDATE name RETURNING**
  - **DELETE FROM name RETURNING**
- In SQL standard, the default value of <cursor updatability> is determined by <select statement>, but in GOLDILOCKS the default value is FOR READ ONLY.
- In SQL standard, <lock wait mode> statement does not exist.

**Table 19-18** SQL standard compatibility

Feature ID	Description	Compatibility
F831	Full cursor update	O
T231	Sensitive cursors	O
F791	Insensitive cursors	O
F431	Read-only scrollable cursors	O
T471	Result sets return value	X
T551	Optional key words for default syntax	O
T111	Updatable joins, unions, and columns	X
B031	Basic dynamic SQL	O

## For More Information

Refer to the followings.

- OPEN cursor\_name
- FETCH cursor\_name
- CLOSE cursor\_name
- PREPARE statement\_name
- SELECT
- SELECT .. FOR UPDATE
- INSERT INTO name RETURNING
- UPDATE name RETURNING
- DELETE FROM name RETURNING

## 19.23 DELETE FROM

### Function

It deletes rows in a table.

### Syntax

```

<delete statement: searched> ::=
    DELETE [ FROM ] table_name [ [ AS ] alias_name ]
        [ WHERE <search condition> ]
        [ <result offset clause> ]
        [ <fetch limit clause> ]
    ;
<result offset clause> ::=
    OFFSET skip_count [ ROW | ROWS ]
<fetch limit clause> ::=
    <fetch first clause>
    | <limit clause>
<fetch first clause> ::=
    FETCH [ FIRST | NEXT ] [ row_count ] [ ROW ONLY | ROWS ONLY ]
<limit clause>
    LIMIT { fetch_row_count | offset_row_count, fetch_row_count | ALL }

```

### Invocation and Access Rules

One of the following privileges is required to perform <delete statement: searched>.

- (DELETE or CONTROL TABLE) ON TABLE for the table
- (DELETE TABLE or CONTROL SCHEMA) ON SCHEMA for the schema to which the table belongs
- DELETE ANY TABLE ON DATABASE



## Syntax Rules and Parameters

### table\_name

It is the name of a target table whose rows are to be deleted.

It defines the schema to which the table belongs such as schema\_name.table\_name.

If schema\_name is omitted, the default schema name of the user performing the statement is used.

### [ AS alias\_name ]

It is the alias of table\_name.

### WHERE <search condition>

It deletes the rows which satisfy WHERE condition.

If WHERE condition is omitted, it deletes all rows.

For more information about WHERE condition, refer to **where clause** of SELECT statement.

### <result offset clause>

It specifies the number of rows to be skipped among the query result.

For more information, refer to **offset limit clause** of SELECT statement.

### <fetch limit clause>

The following two ways are used to specify the number of rows to be fetched.

- <fetch first clause>
  - It specifies the number of rows to be fetched.
  - For more information, refer to **<fetch first clause>** of SELECT statement.
- <limit clause>
  - It specifies the number of rows to be fetched, or it simultaneously specifies both the number of rows to be skipped and the number of rows to be fetched.
  - For more information, refer to **<limit clause>** of SELECT statement.

## Description

### Differences among DELETE-related Statements

- **DELETE FROM**
  - It deletes multiple rows which satisfy conditions.
  - e.g. DELETE FROM t1 WHERE c1 = 0;
- **DELETE FROM name WHERE CURRENT OF cursor\_name**
  - It deletes the row which the current cursor indicates.
  - e.g. DELETE FROM t1 WHERE CURRENT OF cursor;
- **DELETE FROM name RETURNING**
  - It deletes multiple rows which satisfy the conditions, and the deleted rows can be retrieved in the same way as SELECT statement (API such as SQLFetch ()).
  - e.g. DELETE FROM t1 WHERE c1 = 0 RETURNING c2;
- **DELETE FROM name RETURNING .. INTO**
  - It deletes row equal to or less than one, and if one row is deleted, the value is obtained into the host variable of RETURNING INTO clause.
  - e.g. DELETE FROM t1 WHERE c1 = 0 RETURNING c2 INTO :v1;

## Examples

The following is an example of DELETE statement.

```
gSQL> DELETE FROM t1 WHERE id > 3;
2 rows deleted.
```

The following is an example of skipping some rows (two rows) and deleting some rows (two rows) among the rows which satisfy the conditions by using <result offset clause> and <fetch first clause> clauses.

```
gSQL> DELETE FROM t1 OFFSET 2 FETCH 2;
2 rows deleted.
gSQL> SELECT * FROM t1 ORDER BY 1;
ID DATA
-- -----
1 data_1
2 data_2
5 data_5
3 rows selected.
```

## Compatibility

The SQL standard does not define the following clauses of DELETE statement.

- <result offset clause>
- <fetch limit clause>

**Table 19-19** SQL standard compatibility

Feature ID	Description	Compatibility
F781	Self-referencing operations	X
T111	Updatable joins, unions, and columns	X

## For More Information

Refer to the followings.

- DELETE FROM name WHERE CURRENT OF cursor\_name
- DELETE FROM name RETURNING
- DELETE FROM name RETURNING .. INTO
- SELECT

## 19.24 DELETE FROM name RETURNING

### Function

It deletes rows of the table, and retrieves the deleted rows.

### Syntax

```

<delete returning query statement> ::=
    DELETE [ FROM ] table_name [ [ AS ] alias_name ]
        [ WHERE <search condition> ]
        [ <result offset clause> ]
        [ <fetch limit clause> ]
        <returning clause>
    ;
<result offset clause> ::=
    OFFSET skip_count [ ROW | ROWS ]
<fetch limit clause> ::=
    <fetch first clause>
    | <limit clause>
<fetch first clause> ::=
    FETCH [ FIRST | NEXT ] [ row_count ] [ ROW ONLY | ROWS ONLY ]
<limit clause>
    LIMIT { fetch_row_count | offset_row_count, fetch_row_count | ALL }
<returning clause> ::=
    { RETURN | RETURNING } { * | { <value expression> [ [AS] alias_name ] } [, ...] }

```

### Invocation and Access Rules

The user should satisfy the following conditions to perform <delete returning query statement>.

- One of the following privileges is required to perform DELETE statement.
  - (DELETE or CONTROL TABLE) ON TABLE for the table
  - (DELETE TABLE or CONTROL SCHEMA) ON SCHEMA for the schema to which the table belongs
  - DELETE ANY TABLE ON DATABASE

- One of the following privileges is required for all the columns used in RETURNING clause.
  - SELECT(columns) ON TABLE for all columns used in RETURNING clause.
  - (SELECT or CONTROL TABLE) ON TABLE for the table
  - (SELECT TABLE or CONTROL SCHEMA) ON SCHEMA for the schema to which the table belongs
  - SELECT ANY TABLE ON DATABASE

## Syntax Rules and Parameters

### table\_name

It is the name of a target table whose rows are to be deleted.

### [ AS alias\_name ]

It is the alias of table\_name.

### WHERE <search condition>

It deletes the rows which satisfy WHERE condition.

For more information, refer to **DELETE FROM** statement.

### <result offset clause>

It specifies the number of rows to be skipped among the query result.

For more information, refer to **DELETE FROM** statement.

### <fetch first clause>

It specifies the number of rows to be fetched.

For more information, refer to **DELETE FROM** statement.

### <limit clause>

It specifies the number of rows to be fetched, or it simultaneously specifies both the number of rows to be skipped and the number of rows to be fetched.

For more information, refer to **DELETE FROM** statement.

## <returning clause>

It sets the deleted rows as a result set, and it specifies the columns to be searched from the set.

- RETURNING clause returns the rows deleted by DELETE statement as a result set.
- <value expression>
  - It is as same as <select list> of SELECT statement, but it can not use aggregation.
- [[AS] alias\_name]
  - It can give the name to the value expression by using AS clause.

The keywords RETURNING and RETURN have the same meaning.

## Description

For more information, refer to [Differences among DELETE-related Statements](#).

## Examples

The following is an example of deleting rows which satisfy the condition, and searching for the deleted rows.

```
gSQL> DELETE FROM t1 WHERE id > 3 RETURNING *;
ID DATA
-- -----
 4 data_4
 5 data_5
2 rows deleted.
```

The following is an example of querying information of the deleted rows by using operation in RETURNING clause.

```
gSQL> DELETE FROM t1
        WHERE id > 3
        RETURNING 'ID: ' || id || ', DATA: ' || data AS id_data;
ID_DATA
-----
ID: 4, DATA: data_4
ID: 5, DATA: data_5
2 rows deleted.
```

## Compatibility

The SQL standard does not cover <delete returning query statement>.

## For More Information

Refer to the followings.

- DELETE FROM
- DELETE FROM name WHERE CURRENT OF cursor\_name
- DELETE FROM name RETURNING .. INTO
- SELECT

## 19.25 DELETE FROM name RETURNING .. INTO

### Function

It deletes a single row from the table, and the value of the deleted row is obtained into the host variable.

### Syntax

```

<delete returning query statement> ::=
    DELETE [ FROM ] table_name [ [ AS ] alias_name ]
        [ WHERE <search condition> ]
        [ <result offset clause> ]
        [ <fetch limit clause> ]
        <returning into clause>
    ;
<result offset clause> ::=
    OFFSET skip_count [ ROW | ROWS ]
<fetch limit clause> ::=
    <fetch first clause>
    | <limit clause>
<fetch first clause> ::=
    FETCH [ FIRST | NEXT ] [ row_count ] [ ROW ONLY | ROWS ONLY ]
<limit clause>
    LIMIT { fetch_row_count | offset_row_count, fetch_row_count | ALL }
<returning into clause> ::=
    { RETURN | RETURNING } { * | { <value expression> [ [AS] alias_name ] } [, ...] } INTO
    variable_name [, ...]

```

### Invocation and Access Rules

The user should satisfy the following conditions to perform <delete returning into statement>.

- One of the following privileges is required to perform DELETE statement.
  - (DELETE or CONTROL TABLE) ON TABLE for the table
  - (DELETE TABLE or CONTROL SCHEMA) ON SCHEMA for the schema to which the table belongs



- DELETE ANY TABLE ON DATABASE
- One of the following privileges is required for all columns used in RETURNING clause.
  - SELECT(columns) ON TABLE for all columns used in RETURNING clause
  - (SELECT or CONTROL TABLE) ON TABLE for the table
  - (SELECT TABLE or CONTROL SCHEMA) ON SCHEMA for the schema to which the table belongs
  - SELECT ANY TABLE ON DATABASE

## Syntax Rules and Parameters

### table\_name

It is the name of a target table whose rows are to be deleted.

### [ AS alias\_name ]

It is the alias of table\_name.

### WHERE <search condition>

It deletes the rows which satisfy WHERE condition.

For more information, refer to **DELETE FROM** statement.

### <result offset clause>

It specifies the number of rows to be skipped among the query result.

For more information, refer to **DELETE FROM** statement.

### <fetch first clause>

It specifies the number of rows to be fetched.

For more information, refer to **DELETE FROM** statement.

### <limit clause>

It specifies the number of rows to be fetched, or it simultaneously specifies both the number of rows to be skipped and the number of rows to be fetched.

For more information, refer to **DELETE FROM** statement.

## ⟨returning into clause⟩

- RETURNING .. AS ..
  - For more information, refer to ⟨returning clause⟩ of **DELETE FROM name RETURNING** statement.
- INTO variable\_name [, ...]
  - The number of variables specified in INTO clause should be equal to the number of the expressions specified in RETURNING clause.

## Description

The number of rows to be deleted should be equal to or less than one.

If two or more rows are deleted, then an error occurs.

For more information, refer to **Differences among DELETE-related Statements**.

## Example

The following is an example of deleting rows and obtaining the value of deleted rows into the host variable in an interactive SQL (gsq).

```
gsqSQL> \var v_id    INTEGER
gsqSQL> \var v_data  VARCHAR(128)
gsqSQL> DELETE FROM t1 WHERE id = 3 RETURNING id, data INTO :v_id, :v_data;
V_ID V_DATA
---- -
      3 data_3
1 row deleted.
```

## Compatibility

The SQL standard does not cover ⟨delete returning into statement⟩.

## For More Information

Refer to the followings.

- **DELETE FROM**
- **DELETE FROM name WHERE CURRENT OF cursor\_name**
- **DELETE FROM name RETURNING**
- **SELECT**

## 19.26 DELETE FROM name WHERE CURRENT OF cursor\_name

### Function

It deletes a single row which the cursor indicates.

### Syntax

```
<delete statement: positioned> ::=  
    DELETE [ FROM ] table_name [ [ AS ] alias_name ]  
        WHERE CURRENT OF cursor_name  
    ;
```

### Invocation and Access Rules

The privilege to perform **DELETE FROM** statement is required to perform <delete statement: positioned>.

### Syntax Rules and Parameters

#### table\_name

It is the name of a target table whose rows are to be deleted.

#### [ AS alias\_name ]

It is the alias of table\_name.

#### cursor\_name

The cursor corresponding to cursor\_name should satisfy the following conditions.

- The cursor should be OPEN. (Refer to **OPEN cursor\_name**.)

- Fetched rows by using the cursor should exist. (Refer to **FETCH cursor\_name**.)
- The query used for the cursor should identify table\_name. (Refer to **DECLARE cursor\_name**.)
- The cursor should be updatable for table\_name. (Refer to **DECLARE cursor\_name**.)

## Description

For more information, refer to **Differences among DELETE-related Statements**.

## Example

The following is an example of declaring the FOR UPDATE cursor, and deleting rows by using the cursor in interactive SQL (gsq).

```
gsq> DECLARE cur1 CURSOR FOR SELECT id, data FROM t1 FOR UPDATE;
Cursor declared.
gsq> OPEN cur1;
Cursor is open.
gsq> \var v_id    INTEGER
gsq> \var v_data VARCHAR(128)
gsq> FETCH cur1 INTO :v_id, :v_data;
V_ID V_DATA
---- -
      1 data_1
1 row fetched.
gsq> FETCH cur1 INTO :v_id, :v_data;
V_ID V_DATA
---- -
      2 data_2
1 row fetched.
gsq> DELETE FROM t1 WHERE CURRENT OF cur1;
1 row deleted.
gsq> FETCH cur1 INTO :v_id, :v_data;
V_ID V_DATA
---- -
      3 data_3
1 row fetched.
gsq> FETCH cur1 INTO :v_id, :v_data;
V_ID V_DATA
```

```

-----
      4 data_4
1 row fetched.
gSQL> DELETE FROM t1 WHERE CURRENT OF cur1;
1 row deleted.
gSQL> FETCH cur1 INTO :v_id, :v_data;
V_ID V_DATA
-----
      5 data_5
1 row fetched.
gSQL> FETCH cur1 INTO :v_id, :v_data;
no rows fetched.
gSQL> CLOSE cur1;
Cursor closed.
gSQL> SELECT id, data FROM t1 ORDER BY 1;
ID DATA
-- -----
      1 data_1
      3 data_3
      5 data_5
3 rows selected.

```

## Compatibility

Table 19-20 SQL standard compatibility

Feature ID	Description	Compatibility
S111	ONLY in query expressions	X
B031	Basic dynamic SQL	O

## For More Information

Refer to the followings.

- **DECLARE** cursor\_name
- **OPEN** cursor\_name
- **FETCH** cursor\_name
- **DELETE FROM**
- **DELETE FROM** name **RETURNING**

- DELETE FROM name RETURNING .. INTO

## 19.27 DROP AUDIT POLICY

### Function

It drops an audit policy.

### Syntax

```
<drop audit policy statement> ::=  
    DROP AUDIT POLICY [ IF EXISTS ] policy_name  
;
```

### Invocation and Access Rules

AUDIT SYSTEM ON DATABASE privilege is required to perform <drop audit policy statement>.

### Syntax Rules and Parameters

#### IF EXISTS

An error does not occur even when a policy\_name does not exist.

#### policy\_name

It is the name of an audit policy object to be dropped.

### Description

The audit policy object which is already activated can not be dropped. In this case, the audit policy should be deactivated by using NOAUDIT POLICY statement.



## Examples

The following is an example of dropping an audit policy.

```
DROP AUDIT POLICY policy_table;
```

## Compatibility

In the SQL standard, an audit policy does not exist.

## For More Information

Refer to the followings.

- Managing audit policy object
  - CREATE AUDIT POLICY
  - DROP AUDIT POLICY
  - ALTER AUDIT POLICY
- Activating/ deactivating audit policy
  - AUDIT POLICY
  - NOAUDIT POLICY
- Retrieving audit trail: **AUDIT\_TRAIL**
- Clearing audit trail: **ALTER DATABASE CLEAR AUDIT TRAIL**

## 19.28 DROP CLUSTER GROUP

### Function

It drops a cluster group from a cluster system.

### Syntax

```
<drop cluster group statement> ::=  
    DROP CLUSTER GROUP [IF EXISTS] group_name  
    ;
```

### Invocation and Access Rules

It can be performed in a cluster system.

ADMINISTRATION ON DATABASE privilege is required to perform <drop cluster group statement>.

### Syntax Rules and Parameters

#### [IF EXISTS]

An error does not occur even when a cluster group does not exist.

#### group\_name

It is the name of a cluster group.

A cluster group without any shard can be dropped.

### Description

A cluster group can be dropped only when dropping the cluster group does not cause the data loss. However, an error may occur when trying to drop a group including the global coordinator.

## Examples

The following is an example of dropping a cluster group.

```
gSQL> DROP CLUSTER GROUP g3;  
Cluster Group dropped.
```

## Compatibility

The SQL standard does not define the concepts of the cluster.

## For More Information

Refer to [CREATE CLUSTER GROUP](#).

## 19.29 DROP CLUSTER LOCATION

### Function

It drops the access information of a cluster member.

### Syntax

```
<drop cluster location statement> ::=  
    DROP CLUSTER LOCATION member_name  
    ;
```

### Invocation and Access Rules

It can be performed in a cluster system.

ADMINISTRATION ON DATABASE privilege is required to perform <drop cluster location statement>.

### Syntax Rules and Parameters

#### member\_name

It is the name of a cluster member.

The same cluster member name should exist in a registered cluster location information.

The length of the name should be shorter than 128 bytes.

### Description

Generally, the information of the cluster location is automatically created by using the connection information provided when creating the cluster group or adding the cluster member. The created information is deleted together when deleting the cluster member and the cluster group.

If the access information of the cluster location is modified, then the connection information can be modi

fied by using **ALTER CLUSTER LOCATION** without deleting or recreating the cluster member.

## Example

```
gSQL>  
DROP CLUSTER LOCATION g1n2  
;  
Created
```

## Compatibility

The SQL standard does not define the concepts of the cluster.

## For More Information

Refer to the followings.

- **CREATE CLUSTER LOCATION**
- **ALTER CLUSTER LOCATION**

## 19.30 DROP INDEX

### Function

It drops an index.

### Syntax

```
<drop index statement> ::=  
    DROP INDEX [ IF EXISTS ] index_name  
    ;
```

### Invocation and Access Rules

One of the following privileges is required to perform <drop index statement>.

- The owner of that index
- The owner of the table to which the index belongs
- CONTROL TABLE ON TABLE for the table to which the index belongs
- (DROP INDEX or CONTROL SCHEMA) ON SCHEMA for the schema to which the index belongs
- DROP ANY INDEX ON DATABASE

### Syntax Rules and Parameters

#### IF EXISTS

Even when the index does not exist, an error does not occur.

#### index\_name

It is the index name to be dropped.

It can define schema to which the index belongs such as schema\_name.index\_name and if schema\_name is omitted, the default schema name of the user performing the statement is used.

The indexes created for UNIQUE constraint, PRIMARY KEY constraint can not be dropped. To drop the indexes created for the constraints above, the constraints should be removed through **ALTER TABLE name DROP CONSTRAINT** statement.

## Description

Data Definition Language (DDL) statement such as DROP INDEX can be rolled back if it is before when the transaction is committed.

## Examples

The following is an example of dropping an index.

```
gSQL> DROP INDEX idx_t1_id;  
Index dropped.
```

The following is an example of preventing an error even when the index does not exist by using IF EXISTS statement.

```
gSQL> DROP INDEX IF EXISTS not_exist_index;  
Index dropped.
```

## Compatibility

The SQL standard does not cover the concepts of the index.

## For More Information

Refer to the followings.

- CREATE INDEX
- DROP TABLE
- ALTER TABLE name DROP CONSTRAINT

## 19.31 DROP PROFILE

### Function

It drops a profile.

### Syntax

```
<drop profile statement> ::=  
    DROP PROFILE [ IF EXISTS ] profile_name [ CASCADE ] ;
```

### Invocation and Access Rules

DROP PROFILE ON DATABASE privilege is required to perform <drop profile statement>.

### Syntax Rules and Parameters

#### IF EXISTS

Even when the profile does not exist, an error does not occur.

#### profile\_name

It specifies the profile name to be dropped.

It can not drop the DEFAULT profile.

#### CASCADE

If the profile has already been assigned to users, CASCADE clause should be explicitly specified to drop the profile.

The profile which is assigned to users and to be dropped is changed to DEFAULT profile.



## Example

The following is an example of dropping a profile by using CASCADE statement.

```
gSQL> DROP PROFILE prof CASCADE;  
Profile dropped.  
gSQL> COMMIT;  
Commit complete.
```

## Compatibility

The SQL standard does not cover the concepts of the profile.

## For More Information

Refer to the followings.

- CREATE PROFILE
- ALTER PROFILE

## 19.32 DROP SCHEMA

### Function

It drops a schema.

### Syntax

```
<drop schema statement> ::=  
    DROP SCHEMA [ IF EXISTS ] schema_name  
        [ <drop behavior> ]  
    ;  
<drop behavior> ::=  
    RESTRICT  
    | CASCADE
```

### Invocation and Access Rules

One of the following privileges is required to perform <drop schema statement>.

- The owner of that schema
- CONTROL SCHEMA ON SCHEMA for the schema
- DROP SCHEMA ON DATABASE

### Syntax Rules and Parameters

#### IF EXISTS

Even when the schema does not exist, an error does not occur.

## schema\_name

It is the schema name to be dropped.

However, it can not drop the built-in schema such as "DICTIONARY\_SCHEMA", "INFORMATION\_SCHEMA" and "PUBLIC" which are automatically created when creating the database.

### <drop behavior>

- When it is RESTRICT
  - Objects should not exist within the schema.
- When it is CASCADE
  - It drops all objects in the schema together.
- When it is omitted, the default value is RESTRICT.

## Description

Data Definition Language (DDL) statement such as DROP SCHEMA can be rolled back if it is before when the transaction is committed. In this case, recycle bin objects which are included in the schema to be dropped are also dropped.

## Examples

The following is an example of dropping a schema and all objects which exist within the schema.

```
gSQL> DROP SCHEMA s1 CASCADE;  
Schema dropped.
```

The following is an example of preventing an error even when the schema does not exist by using IF EXISTS statement.

```
gSQL> DROP SCHEMA IF EXISTS not_exist_schema;  
Schema dropped.
```

## Compatibility

The SQL standard does not define IF EXISTS clause.

**Table 19-21** SQL standard compatibility

Feature ID	Description	Compatibility
F032	CASCADE drop behavior	O
F381	Extended schema manipulation	O

## For More Information

Refer to **CREATE SCHEMA**.

## 19.33 DROP SEQUENCE

### Function

It drops a sequence.

### Syntax

```
<drop sequence generator statement> ::=  
    DROP SEQUENCE [ IF EXISTS ] [schema_name.] sequence_name  
    ;
```

### Invocation and Access Rules

One of the following privileges is required to perform <drop sequence generator statement>.

- The owner of that sequence
- (DROP SEQUENCE or CONTROL SCHEMA) ON SCHEMA for the schema to which the sequence belongs
- DROP ANY SEQUENCE ON DATABASE

### Syntax Rules and Parameters

#### IF EXISTS

Even when the sequence does not exist, an error does not occur.

#### sequence\_name

It is the sequence name to be dropped.

It can define schema to which the sequence belongs such as schema\_name.sequence\_name and if schema\_name is omitted, the default schema name of the user performing the statement is used.

## Description

Data Definition Language (DDL) statement such as DROP SEQUENCE can be rolled back if it is before when the transaction is committed.

## Examples

The following is an example of dropping a sequence.

```
gSQL> DROP SEQUENCE seq1;
Sequence dropped.
```

The following is an example of preventing an error even when the sequence does not exist by using IF EXISTS statement.

```
gSQL> DROP SEQUENCE invalid_sequence;
ERR-42000(16044): sequence does not exist :
DROP SEQUENCE invalid_sequence
          *
ERROR at line 1:
gSQL> DROP SEQUENCE IF EXISTS invalid_sequence;
Sequence dropped.
```

## Compatibility

The SQL standard does not define IF EXISTS clause.

**Table 19-22** SQL standard compatibility

Feature ID	Description	Compatibility
T176	Sequence generator support	O

## For More Information

Refer to the followings.

- CREATE SEQUENCE

- ALTER SEQUENCE

## 19.34 DROP SYNONYM

### Function

It drops a synonym.

### Syntax

```
<drop synonym statement> ::=  
    DROP [ PUBLIC ] SYNONYM [ IF EXISTS ] [schema_name.]synonym_name  
    ;
```

### Invocation and Access Rules

DROP PUBLIC SYNONYM ON DATABASE privilege is required to drop a public synonym by specifying PUBLIC.

One of the following privileges is required to drop a private synonym.

- The owner of that synonym
- (DROP SYNONYM or CONTROL SCHEMA) ON SCHEMA for the schema to which the synonym belongs
- DROP ANY SYNONYM ON DATABASE

### Syntax Rules and Parameters

#### [ PUBLIC ]

It is specified when dropping the public synonym.

If this clause is omitted, the private synonym is dropped.



## IF EXISTS

Even when the synonym does not exist, an error does not occur.

### **synonym\_name**

It is the synonym name to be dropped.

It can define schema to which the synonym belongs such as `schema_name.synonym_name` and if `schema_name` is omitted, the default schema name of the user performing the statement is used.

If `PUBLIC` is explicitly specified, the schema name can not be specified.

## Description

Data Definition Language (DDL) statement such as `DROP SYNONYM` can be rolled back if it is before when the transaction is committed.

## Examples

The following is an example of dropping a private synonym.

```
gSQL> DROP SYNONYM MyEmp;  
Synonym dropped.
```

The following is an example of dropping a public synonym.

```
gSQL> DROP PUBLIC SYNONYM MainEmp;  
Synonym dropped.
```

## Compatibility

The SQL standard does not define `DROP SYNONYM` statement.

## For More Information

Refer to `CREATE SYNONYM`.

## 19.35 DROP TABLE

### Function

It drops a table.



If the recycle bin feature is activated, the table is not completely dropped but it is stored in the recycle bin.

### Syntax

```
<drop table statement> ::=
    DROP TABLE [ IF EXISTS ] table_name
    [ <drop behavior> ]
    [ PURGE ]
    ;
<drop behavior> ::=
    RESTRICT
    | CASCADE
    | CASCADE CONSTRAINTS
```

### Invocation and Access Rules

One of the following privileges is required to perform <drop table statement>.

- The owner of that table
- CONTROL TABLE ON TABLE for that table
- (DROP TABLE or CONTROL SCHEMA) ON SCHEMA for the schema to which the table belongs
- DROP ANY TABLE ON DATABASE

## Syntax Rules and Parameters

### IF EXISTS

Even when the table does not exist, an error does not occur.

### table\_name

It is the table name to be dropped.

It can define schema to which the table belongs such as schema\_name.table\_name and if schema\_name is omitted, the default schema name of the user performing the statement is used.

The following tables which are automatically created during creating the database, can not be dropped.

- The tables in "DEFINITION\_SCHEMA" schema
- The tables in "FIXED\_TABLE\_SCHEMA" schema

It also drops constraints and indexes created in the table.

### drop behavior

Currently, both RESTRICT and CASCADE are operated same.

When it is omitted, the default value is RESTRICT.

### purge

It immediately drops a table instead of storing it in the recycle bin even when the recycle bin feature is activated.

## Description

Data Definition Language (DDL) statement such as DROP TABLE can be rolled back if it is before when the transaction is committed.

## Examples

The following is an example of dropping an ordinary table.

```
gSQL> DROP TABLE region;  
Table dropped.
```

The following is an example of preventing an error even when the table does not exist by using IF EXISTS statement.

```
gSQL> DROP TABLE IF EXISTS invalid_table;  
Table dropped.
```

The following is an example of rolling back the dropped table.

```
gSQL> SELECT r_regionkey, r_name FROM region;  
R_REGIONKEY R_NAME  
-----  
0 AFRICA  
1 AMERICA  
2 ASIA  
3 EUROPE  
4 MIDDLE EAST  
5 rows selected.  
gSQL> DROP TABLE region;  
Table dropped.  
gSQL> SELECT r_regionkey, r_name FROM region;  
ERR-42000(16040): table or view does not exist :  
SELECT r_regionkey, r_name FROM region  
                                     *  
ERROR at line 1:  
gSQL> ROLLBACK;  
Rollback complete.  
gSQL> SELECT r_regionkey, r_name FROM region;  
R_REGIONKEY R_NAME  
-----  
0 AFRICA  
1 AMERICA  
2 ASIA  
3 EUROPE  
4 MIDDLE EAST
```

5 rows selected.

## Compatibility

The SQL standard does not define the following clauses.

- IF EXISTS
- CASCADE CONSTRAINTS

**Table 19-23** SQL standard compatibility

Feature ID	Description	Compatibility
F032	CASCADE drop behavior	O

## For More Information

Refer to `CREATE TABLE`.

## 19.36 DROP TABLESPACE

### Function

It drops a tablespace.

### Syntax

```
<drop tablespace statement> ::=  
    DROP TABLESPACE [ IF EXISTS ] tablespace_name  
        [ INCLUDING CONTENTS ]  
        [ { AND | KEEP } DATAFILES ]  
        [ <drop behavior> ]  
    ;  
<drop behavior> ::=  
    RESTRICT  
    | CASCADE  
    | CASCADE CONSTRAINTS
```

### Invocation and Access Rules

DROP TABLESPACE ON DATABASE privilege is required to perform <drop tablespace definition>.

### Syntax Rules and Parameters

#### IF EXISTS

Even when the tablespace does not exist, an error does not occur.

#### tablespace\_name

It is the tablespace name to be dropped.

The following system tablespaces which are automatically created during creating the database, can not

be dropped.

- `DICTIONARY_TBS`: system tablespace for dictionary management
- `MEM_UNDO_TBS`: system tablespace for default undo tablespace
- `MEM_DATA_TBS`: system tablespace for default user data tablespace
- `MEM_TEMP_TBS`: system tablespace for default temporary tablespace



If `tablespace_name` was used as a default tablespace of a user, the space for the objects can not be allocated after dropping the tablespace.

After dropping the tablespace, the default tablespace should be changed by using **ALTER USER** statement.

## INCLUDING CONTENTS

It drops objects (table, index, key constraint) which belong to the tablespace. If the index or key constraint which refers to the table which belongs to the tablespace exists outside of the tablespace, then it is also dropped.

If `INCLUDING CONTENTS` clause is not used, then any object which belongs to the tablespace should not exist.

## [ { AND | KEEP } DATAFILES ]

It specifies whether to drop the datafiles which configure the tablespace together. The datafiles are not in the memory temporary tablespace, so the clause is ignored.

- `AND DATAFILES`
  - It drops the datafiles together.
- `KEEP DATAFILES`
  - It does not drop the datafiles, but keeps them.
- If it is not specified, the default value is `KEEP DATAFILES`.

## drop behavior

Currently, both `RESTRICT` and `CASCADE` are operated same.

When it is omitted, the default value is `RESTRICT`.



## Description

Unlike other Data Definition Language (DDL), DROP TABLESPACE statement can not be rolled back and the executed transaction is automatically committed. In this case, recycle bin objects which are included in the tablespace to be dropped are also dropped.

## Examples

The following is an example of dropping a tablespace together with all objects in the tablespace and data files which configure the tablespace.

```
gSQL> DROP TABLESPACE space1 INCLUDING CONTENTS AND DATAFILES CASCADE CONSTRAINTS;  
Tablespace dropped.
```

The following is an example of preventing an error even when the tablespace does not exist by using IF EXISTS statement.

```
gSQL> DROP TABLESPACE IF EXISTS not_exist_tablespace;  
Tablespace dropped.
```

## Compatibility

The SQL standard does not cover the concepts of the tablespace.

## For More Information

Refer to the followings.

- CREATE MEMORY DATA TABLESPACE
- CREATE MEMORY TEMPORARY TABLESPACE
- ALTER TABLESPACE

## 19.37 DROP USER

### Function

It drops a database user.

### Syntax

```
<drop user statement> ::=  
    DROP USER [ IF EXISTS ] user_identifier [ <drop behavior> ]  
    ;  
<drop behavior> ::=  
    RESTRICT  
    | CASCADE
```

### Invocation and Access Rules

DROP USER ON DATABASE privilege is required to perform <drop user statement>.



The schema owned by user\_identifier should not exist.  
For more information about dropping the schema, refer to **DROP SCHEMA**.

### Syntax Rules and Parameters

#### IF EXISTS

Even when the user does not exist, an error does not occur.

#### user\_identifier

It is the database username to be dropped.

However, the user which is automatically created during creating the database such as "SYS", can not be

dropped.

It does not drop the object which is created by user\_identifier but is not an owner as follows.

- Role
- Tablespace

## <drop behavior>

- RESTRICT
  - There should not be the following user owned SQL schema objects.
    - Table, view
    - Index
    - Sequence
    - Table constraint
- CASCADE
  - It drops all the following user owned SQL schema objects.
    - Table, view
    - Index
    - Sequence
    - Table constraint
- When it is omitted, the default value is RESTRICT.



### The relationship between user and schema in other DBMS

- Oracle
  - User : schema = 1 : 1.
  - When CASCADE, the schema is also dropped.
- DB2
  - It is as same as the OS user.
  - The separate SQL statements which create or delete a user do not exist.
- Postgres
  - User : schema = 1 : N.
  - It does not support CASCADE option, and a user can be dropped after dropping all the objects owned by the user and all the privileges granted to other users.

- MySQL
  - Database : schema = 1 : 1.
  - User is a subordinate object of database (schema), and it does not support CASCADE option.

## Description

In GOLDILOCKS, relationship between the user and the schema is 1 : N. A user does not own a schema, or the user can have multiple schemas.

To drop a user, all schema owned by the user should be dropped. In this case, recycle bin objects of the user to be dropped are also dropped.

## Examples

The following is an example of dropping all schema owned by the user and then dropping the user.

```
gSQL> DROP SCHEMA u1 CASCADE;  
Schema dropped.  
gSQL> DROP USER u1 CASCADE;  
User dropped.
```

The following is an example of preventing an error even when the user does not exist by using IF EXISTS statement.

```
gSQL> DROP USER IF EXISTS not_exist_user;  
User dropped.
```

## Compatibility

SQL standard cover the concepts of the user, but they do not define the SQL statements related to creating or dropping a user.

## For More Information

Refer to the followings.

- [CREATE USER](#)
- [ALTER USER](#)
- [DROP SCHEMA](#)

## 19.38 DROP VIEW

### Function

It drops a view.

### Syntax

```
<drop view statement> ::=  
    DROP VIEW [ IF EXISTS ] view_name  
    ;
```

### Invocation and Access Rules

One of the following privileges is required to perform <drop view statement>.

- The owner of that view
- CONTROL TABLE ON TABLE for that view
- (DROP VIEW or CONTROL SCHEMA) ON SCHEMA for the schema to which the view belongs
- DROP ANY VIEW ON DATABASE

### Syntax Rules and Parameters

#### IF EXISTS

Even when the view does not exist, an error does not occur.

#### view\_name

It is the view name to be dropped.

The schema to which the table belongs, such as schema\_name.view\_name, can be defined. If schema\_name is omitted, the default schema name of the user performing the statement is used.

## Description

Data Definition Language (DDL) statement such as DROP VIEW can be rolled back if it is before when the transaction is committed.

## Examples

The following is an example of dropping a view.

```
gSQL> DROP VIEW v1;  
View dropped.
```

The following is an example of preventing an error even when the view does not exist by using IF EXISTS statement.

```
gSQL> DROP VIEW IF EXISTS not_exist_view;  
View dropped.
```

## Compatibility

The SQL standard does not define IF EXISTS clause.

**Table 19-24** SQL standard compatibility

Feature ID	Description	Compatibility
F032	CASCADE drop behavior	X

## For More Information

Refer to the followings.

- CREATE VIEW
- ALTER VIEW

## 19.39 EXECUTE IMMEDIATE 'sql\_string'

### Function

It executes a dynamic SQL statement which was not defined when writing a program.

### Syntax

```
<execute immediate statement> ::=
    EXECUTE IMMEDIATE <SQL statement variable>
    ;
<SQL statement variable> ::=
    variable_name
    | 'sql statement'
    | "sql statement"
    | sql statement
```

### Invocation and Access Rules

It can be used in an embedded SQL.

An appropriate privilege according to the type of a dynamic SQL statement is required.

### Syntax Rules and Parameters

#### <SQL statement variable>

The dynamic SQL statement referenced by <SQL statement variable> can not use a host variable (:var) or parameter marker (?).

The following four types of <SQL statement variable> can be used.

- `variable_name`: It is a variable in which an SQL statement is stored.
- `'sql statement'`: It is an SQL statement which is enclosed with a single quote (').
- `"sql statement"`: It is an SQL statement which is enclosed with double quotes (").



- sql statement: It is an SQL statement without quote.

The single quote (') is used twice as follows to represent string data within a single-quoted string.

```
{  
    ...  
    EXEC SQL EXECUTE IMMEDIATE 'INSERT INTO t1 VALUES ( ''literal data'' )';  
    ...  
}
```

If the SQL statement is a query including a query result, it is successfully executed, but the result can not be obtained.

## variable\_name

The type corresponding to the variable\_name should be a character string.  
The dynamic SQL statement defined in the variable\_name should be valid.

## sql statement

The dynamic SQL statement defined in the sql statement should be valid.

## Description

EXECUTE IMMEDIATE 'sql\_string' statement can be used as the non-query SQL without a host variable in dynamic embedded SQL application. It is appropriate to execute DDL, DML as one-off because it does not require separate preparation procedure.

For more information, refer to [Embedded Dynamic SQL](#).

## Example

The following is an example of using EXECUTE IMMEDIATE 'sql\_string' in the embedded SQL source code.

```
{  
    ...  
    sprintf(sSqlStmt, "INSERT INTO EMP_RND\n"
```

```

        "SELECT *\n"
        "FROM   EMP\n"
        "WHERE  JOB = 'RND'\n" );
EXEC SQL EXECUTE IMMEDIATE :sSqlStmt;
if(sqlca.sqlcode != 0)
{
    goto fail_exit;
}
...
}

```

The full source code in which EXECUTE IMMEDIATE 'sql\_string' was used can be viewed in [Dynamic Embedded SQL Example Program](#).

## Compatibility

**Table 19-25** SQL standard compatibility

Feature ID	Description	Compatibility
B031	Basic Dynamic SQL	O

## For More Information

Refer to the followings.

- `PREPARE statement_name`
- `EXECUTE statement_name`
- Embedded Dynamic SQL

## 19.40 EXECUTE statement\_name

### Function

It executes the prepared statement.

### Syntax

```
<execute statement> ::=
    EXECUTE statement_name [ <parameter using clause> ] [ <result into clause> ]
    ;
<parameter using clause> ::=
    <using parameter arguments>
<using parameter arguments> ::=
    USING variable_name [, ...]
<result into clause> ::=
    <into result arguments>
<into result arguments> ::=
    INTO variable_name [, ...]
```

### Invocation and Access Rules

It can be used in an embedded SQL.

An appropriate privilege according to the type of a dynamic SQL statement is required.

### Syntax Rules and Parameters

#### statement\_name

It is the name of a prepared statement.

Statement\_name should be prepared by using **PREPARE statement\_name**.

If the dynamic SQL statement referenced by `statement_name` contains a dynamic parameter, `<parameter using clause>` should explicitly be specified.

```
{
  ...
  EXEC SQL PREPARE stmt1 FROM 'DELETE FROM t1 WHERE c1 > ?';
  EXEC SQL EXECUTE stmt1 USING :sValue;
  ...
}
```

```
{
  ...
  EXEC SQL PREPARE stmt1 FROM 'SELECT COUNT(*) INTO :v1 FROM t1';
  EXEC SQL EXECUTE stmt1 USING :sValue;
  ...
}
```

If the dynamic SQL statement referenced by `statement_name` is a query or a stored function including the result, `<result into clause>` should explicitly be specified.

```
{
  ...
  EXEC SQL PREPARE stmt1 FROM 'SELECT COUNT(*) FROM t1';
  EXEC SQL EXECUTE stmt1 INTO :sValue;
  ...
}
```

If there are multiple queries they are normally executed, but only the first query can get the result. To get multiple results, the following statements related to the cursor should be used.

- **DECLARE** `cursor_name`
- **OPEN** `cursor_name`
- **FETCH** `cursor_name`
- **CLOSE** `cursor_name`

If there is not any query result, it is completed as NO DATA.

## [ `<parameter using clause>` ] [ `<result into clause>` ]

`<parameter using clause>` and `<result into clause>` can be specified in any order, but they should not be repeated.

## <parameter using clause>

If any parameter exists in a dynamic SQL statement referenced by statement\_name, the parameter information is specified with <using parameter arguments> clause.

## <using parameter arguments>

If <using parameter arguments> statement is used, the number of variable\_name should be equal to the number of the parameter included in the dynamic SQL statement referenced by statement\_name.

The listed variable\_name corresponds to the dynamic parameter in an order of its description.

```
{
  ...
  EXEC SQL PREPARE stmt1 FROM 'DELETE FROM t1 WHERE c1 IN ( ?, ?, ? )';
  EXEC SQL EXECUTE stmt1 USING :sValue1, :sValue2, :sValue3;
  ...
}
```

## <result into clause>

If the dynamic SQL statement referenced by statement\_name is a query, the information about the result columns is specified with <into result arguments> clause.

If the result is null and INDICATOR is not specified, [DATA EXCEPTION, NULL VALUE, NO INDICATOR PARAMETER] error occurs.

## <into result arguments>

If <into result arguments> clause is used, the number of variable\_name should be equal to the number of the result column in the dynamic SQL statement referenced by statement\_name.

The listed variable\_name corresponds to the dynamic parameter in an order of its description.

```
{
  ...
  EXEC SQL PREPARE stmt1 FROM 'SELECT MIN(salary), MAX(salary), AVG(salary) FROM employee';
  EXEC SQL EXECUTE stmt1 INTO :sMinValue, :sMaxValue, :sAvgValue;
  ...
}
```

## Description

Statement\_name is an identifier which informs the precompiler the statement in an embedded SQL source code.

A separate type or declaration is not required because statement\_name is not a host variable. EXECUTE statement\_name should be written after PREPARE statement\_name.

For more information, refer to **Embedded Dynamic SQL**.

## Example

The following is an example of using EXECUTE statement\_name in an embedded SQL source code.

```
{
    ...
    sprintf( sUpdateSql, "UPDATE EMP SET sal = sal * :v1 WHERE JOB = 'SALES'");
    EXEC SQL PREPARE UPDATE_STMT FROM :sUpdateSql;
    if(sqlca.sqlcode != 0)
    {
        goto fail_exit;
    }
    sRatio = 1.1;
    EXEC SQL EXECUTE UPDATE_STMT USING :sRatio;
    if(sqlca.sqlcode != 0)
    {
        goto fail_exit;
    }
    ...
}
```

The full source code in which EXECUTE statement\_name was used can be viewed in **Dynamic Embedded SQL Example Program**.

## Compatibility

**Table 19-26** SQL standard compatibility

Feature ID	Description	Compatibility
B031	Basic Dynamic SQL	O
B032	Extended dynamic SQL	X

## For More Information

Refer to the followings.

- **PREPARE statement\_name**
- **DECLARE cursor\_name**
- **OPEN cursor\_name**
- **FETCH cursor\_name**
- **CLOSE cursor\_name**
- **Embedded Dynamic SQL**

## 19.41 FETCH cursor\_name

### Function

It locates the cursor on a specific row of result set, and obtains the value of that row to a host variable.

### Syntax

```
<fetch statement> ::=
    FETCH [ <fetch orientation> ] [ FROM ] cursor_name
        <result into clause>
    ;
<fetch orientation> ::=
    NEXT
    | PRIOR
    | FIRST
    | LAST
    | CURRENT
    | ABSOLUTE position
    | RELATIVE position
<result into clause> ::=
    <into result arguments>
<into result arguments> ::=
    INTO variable_name [, ...]
```

### Syntax Rules and Parameters

#### [ FROM ] cursor\_name

It should be an open cursor in a session.

FROM can be omitted.



## <fetch orientation>

To use <fetch orientation> other than FETCH NEXT, a scrollable cursor should be used. If <fetch orientation> is omitted, the default value is NEXT.

The open cursor has the cursor position information for the result set as follows.

**Figure 1** The position of cursor

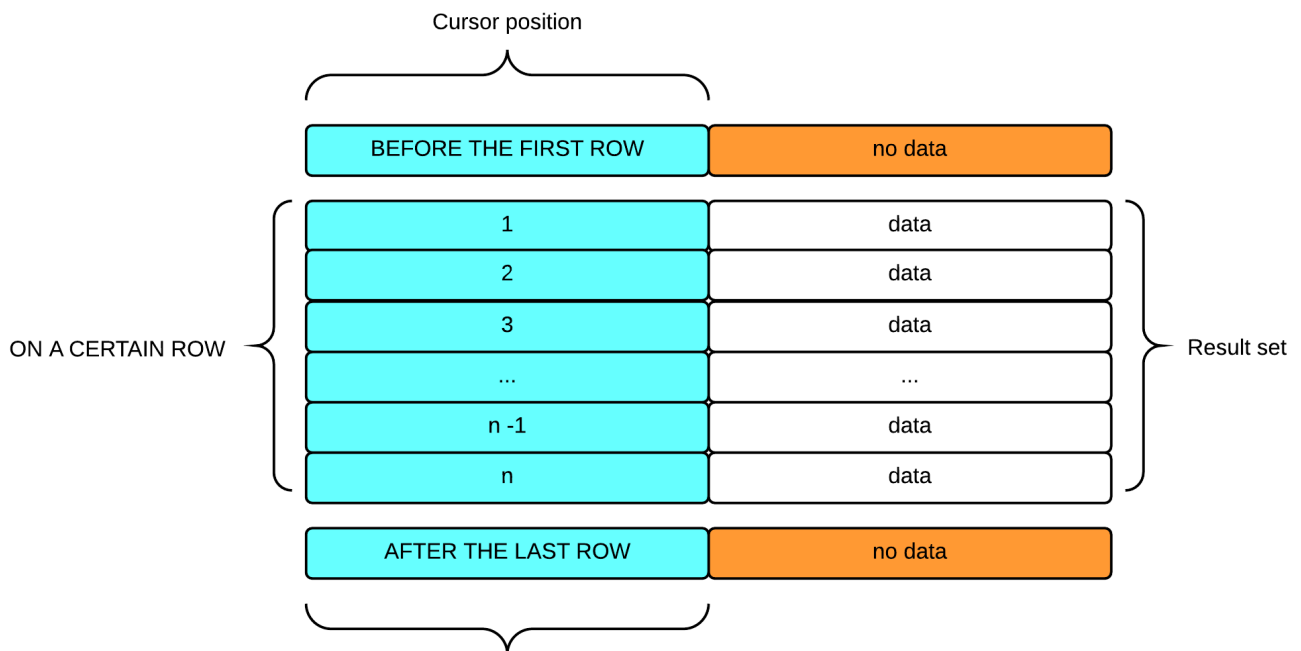

**Table 19-27** The position of cursor

Cursor position	Description
BEFORE THE FIRST ROW	The cursor is positioned before the first row of the result set. It is also the cursor position when opening it.
ON A CERTAIN ROW	The cursor is positioned on a certain row of the result set through FETCH.
AFTER THE LAST ROW	The cursor is positioned after the last row of the result set.

Each <fetch orientation> operates based on the cursor position as follows.

- NEXT: It searches for the row next to the current position.
- PRIOR: It searches for the row prior to the current position.
- FIRST: It searches for the first row of the result set.
- LAST: It searches for the last row of the result set.
- CURRENT: It searches for the row in the current position.
- ABSOLUTE position
  - It searches for the row corresponding to the position from the result set.
  - If the position value is negative, it searches for the row at previous position from AFTER THE LAST ROW.

- RELATIVE position
  - It searches for the row apart as much as position from the current position.

## ⟨result into clause⟩

The variable information to obtain the result column is specified by using ⟨into result arguments⟩.

If the result is null and INDICATOR is not specified, [DATA EXCEPTION, NULL VALUE, NO INDICATOR PARAMETER] error occurs.

## ⟨into result arguments⟩

The number of variables in INTO clause should be as same as the number of columns in the result set of the cursor.

## Description

If the cursor is BEFORE THE FIRST ROW or AFTER THE LAST ROW after performing FETCH, it is positioned at the same position regardless of the entered position in ⟨fetch orientation⟩.

## Example

The following is an example of declaring SCROLL cursor by using the interactive SQL (gsql), then operating the various ⟨fetch orientation⟩.

```
gSQL> DECLARE cur_scroll SCROLL CURSOR FOR SELECT id, data FROM t1;
Cursor declared.
gSQL> OPEN cur_scroll;
Cursor is open.
gSQL> \var v_id    INTEGER
gSQL> \var v_data VARCHAR(128)
gSQL> FETCH NEXT cur_scroll INTO :v_id, :v_data;
V_ID V_DATA
---- -
      1 data_1
1 row fetched.
gSQL> FETCH NEXT cur_scroll INTO :v_id, :v_data;
V_ID V_DATA
```

```
-----  
      2 data_2  
1 row fetched.  
gSQL> FETCH PRIOR cur_scroll INTO :v_id, :v_data;  
V_ID V_DATA  
-----  
      1 data_1  
1 row fetched.  
gSQL> FETCH PRIOR cur_scroll INTO :v_id, :v_data;  
no rows fetched.  
gSQL> FETCH FIRST cur_scroll INTO :v_id, :v_data;  
V_ID V_DATA  
-----  
      1 data_1  
1 row fetched.  
gSQL> FETCH FIRST cur_scroll INTO :v_id, :v_data;  
V_ID V_DATA  
-----  
      1 data_1  
1 row fetched.  
gSQL> FETCH LAST cur_scroll INTO :v_id, :v_data;  
V_ID V_DATA  
-----  
      5 data_5  
1 row fetched.  
gSQL> FETCH LAST cur_scroll INTO :v_id, :v_data;  
V_ID V_DATA  
-----  
      5 data_5  
1 row fetched.  
gSQL> FETCH FIRST cur_scroll INTO :v_id, :v_data;  
V_ID V_DATA  
-----  
      1 data_1  
1 row fetched.  
gSQL> FETCH CURRENT cur_scroll INTO :v_id, :v_data;  
V_ID V_DATA  
-----  
      1 data_1  
1 row fetched.  
gSQL> FETCH LAST cur_scroll INTO :v_id, :v_data;
```

```
V_ID V_DATA
-----
      5 data_5
1 row fetched.
gSQL> FETCH CURRENT cur_scroll INTO :v_id, :v_data;
V_ID V_DATA
-----
      5 data_5
1 row fetched.
gSQL> FETCH ABSOLUTE 3 cur_scroll INTO :v_id, :v_data;
V_ID V_DATA
-----
      3 data_3
1 row fetched.
gSQL> FETCH CURRENT cur_scroll INTO :v_id, :v_data;
V_ID V_DATA
-----
      3 data_3
1 row fetched.
gSQL> FETCH ABSOLUTE 1 cur_scroll INTO :v_id, :v_data;
V_ID V_DATA
-----
      1 data_1
1 row fetched.
gSQL> FETCH ABSOLUTE -1 cur_scroll INTO :v_id, :v_data;
V_ID V_DATA
-----
      5 data_5
1 row fetched.
gSQL> FETCH ABSOLUTE 6 cur_scroll INTO :v_id, :v_data;
no rows fetched.
gSQL> FETCH ABSOLUTE -6 cur_scroll INTO :v_id, :v_data;
no rows fetched.
gSQL> FETCH ABSOLUTE 3 cur_scroll INTO :v_id, :v_data;
V_ID V_DATA
-----
      3 data_3
1 row fetched.
gSQL> FETCH ABSOLUTE -3 cur_scroll INTO :v_id, :v_data;
V_ID V_DATA
-----
```

```

    3 data_3
1 row fetched.
gSQL> FETCH RELATIVE 1 cur_scroll INTO :v_id, :v_data;
V_ID V_DATA
-----
    4 data_4
1 row fetched.
gSQL> FETCH RELATIVE -1 cur_scroll INTO :v_id, :v_data;
V_ID V_DATA
-----
    3 data_3
1 row fetched.
gSQL> FETCH RELATIVE 5 cur_scroll INTO :v_id, :v_data;
no rows fetched.
gSQL> FETCH RELATIVE -5 cur_scroll INTO :v_id, :v_data;
V_ID V_DATA
-----
    1 data_1
1 row fetched.
gSQL> CLOSE cur_scroll;
Cursor closed.

```

## Compatibility

The SQL standard does not define CURRENT among <fetch orientation>.

**Table 19-28** SQL standard compatibility

Feature ID	Description	Compatibility
F431	Read-only scrollable cursors	O
B031	Basic dynamic SQL	O

## For More Information

Refer to the followings.

- **DECLARE cursor\_name**
- **OPEN cursor\_name**
- **CLOSE cursor\_name**

## 19.42 FLASHBACK TABLE

### Function

It restores the table object which is stored in the recycle bin.

### Syntax

```
<flashback table statement> ::=  
    FLASHBACK TABLE table_name  
    TO BEFORE DROP [ RENAME TO new_table_name ]  
    ;
```

### Invocation and Access Rules

One of the following privileges is required to perform <flashback table statement>.

- The owner of that table
- CONTROL TABLE ON TABLE for that table
- (DROP TABLE or CONTROL SCHEMA) ON SCHEMA for the schema to which the table belongs
- DROP ANY TABLE ON DATABASE

### Syntax Rules and Parameters

#### table\_name

It is the name of the object stored or of the dropped table in the recycle bin.

It can define the schema to which the table belongs in the dropped table name, such as schema\_name.table\_name. If schema\_name is omitted, the default schema name of the user performing the statement is used.

## new\_table\_name

It is a new name of the table to be restored.

The duplicate table name should not exist within a single schema.

## Description

It restores the table object which is stored in the recycle bin by using the object name or the dropped table name stored in the recycle bin. If the name which is as same as that of the dropped table exists, then the newest table object is restored.

If the name which is as same as that of the table object to be restored exists, then an error occurs, but it can be restored with the new name by using RENAME TO clause. The constraints and the indexes of the restored tables are restored in its name of when before they were dropped. However, if their names of when before the constraints and the indexes were dropped already exist, then the object is restored in the name of when it is stored in the recycle bin.

Unlike other Data Definition Language (DDL), FLASHBACK TABLE statement can not be rolled back and the executed transaction is automatically committed.

## Example

The following is an example of restoring a table with the name of the object stored in the recycle bin.

```
gSQL> SELECT SCHEMA_NAME, OBJECT_NAME, ORIGINAL_NAME, OBJECT_TYPE FROM USER_RECYCLEBIN;
SCHEMA_NAME OBJECT_NAME                                ORIGINAL_NAME OBJECT_TYPE
-----
PUBLIC      BIN$106A4F90165D11EA9C5C835D3E4BBBF7 T1          TABLE
1 row selected.
gSQL> FLASHBACK TABLE "BIN$106A4F90165D11EA9C5C835D3E4BBBF7" TO BEFORE DROP;
Flashback complete.
```

The following is an example of restoring the table from the recycle bin in the name of when before it is dropped.

```
gSQL> SELECT SCHEMA_NAME, OBJECT_NAME, ORIGINAL_NAME, OBJECT_TYPE FROM USER_RECYCLEBIN;
SCHEMA_NAME OBJECT_NAME                                ORIGINAL_NAME OBJECT_TYPE
-----
PUBLIC      BIN$106A4F90165D11EA9C5C835D3E4BBBF7 T1          TABLE
```

```
gSQL> FLASHBACK TABLE T1 TO BEFORE DROP;  
Flashback complete.
```

## Compatibility

The SQL standard does not define <flashback table statement>.

## For More Information

Refer to the followings.

- [Managing Recycle Bin of Table](#)
- [PURGE](#)



## 19.43 GRANT privileges TO

### Function

It grants privileges to a user.

### Syntax

```

<grant privilege statement> ::=
    GRANT <privilege> TO <grantee> [, ...]
        [ WITH GRANT OPTION ]
    ;

<grantee> ::=
    PUBLIC
    | user_identifier
    ;

<privilege> ::=
    <database privilege>
    | <tablespace privilege>
    | <schema privilege>
    | <table privilege>
    | <sequence privilege>
    | <procedure privilege>

<database privilege> ::=
    ALL [ PRIVILEGES ] [ ON DATABASE]
    | <database action> [, ...] [ ON DATABASE]

<database action> ::=
    ADMINISTRATION
    | ANALYZE ANY
    | ALTER DATABASE
    | ALTER SYSTEM
    | AUDIT SYSTEM
    | ACCESS CONTROL
    | CREATE SESSION
    | CREATE PROFILE
    | ALTER PROFILE
  
```

- | DROP PROFILE
- | CREATE USER
- | ALTER USER
- | DROP USER
- | CREATE ROLE
- | ALTER ROLE
- | DROP ROLE
- | CREATE TABLESPACE
- | ALTER TABLESPACE
- | DROP TABLESPACE
- | USAGE TABLESPACE
- | CREATE SCHEMA
- | ALTER SCHEMA
- | DROP SCHEMA
- | CREATE PUBLIC SYNONYM
- | DROP PUBLIC SYNONYM
- | CREATE ANY TABLE
- | ALTER ANY TABLE
- | DROP ANY TABLE
- | SELECT ANY TABLE
- | INSERT ANY TABLE
- | DELETE ANY TABLE
- | UPDATE ANY TABLE
- | LOCK ANY TABLE
- | CREATE ANY VIEW
- | DROP ANY VIEW
- | CREATE ANY SEQUENCE
- | ALTER ANY SEQUENCE
- | DROP ANY SEQUENCE
- | USAGE ANY SEQUENCE
- | CREATE ANY INDEX
- | ALTER ANY INDEX
- | DROP ANY INDEX
- | CREATE ANY SYNONYM
- | DROP ANY SYNONYM
- | CREATE ANY PROCEDURE
- | ALTER ANY PROCEDURE
- | DROP ANY PROCEDURE
- | EXECUTE ANY PROCEDURE
- | CREATE ANY PACKAGE
- | ALTER ANY PACKAGE

```
| DROP ANY PACKAGE
| EXECUTE ANY PACKAGE
| PURGE DBA_RECYCLEBIN
<tablespace privilege> ::=
    ALL [ PRIVILEGES ] ON TABLESPACE tablespace_name
    | <tablespace action> [, ...] ON TABLESPACE tablespace_name
<tablespace action> ::=
    CREATE OBJECT
<schema privilege> ::=
    ALL [ PRIVILEGES ] ON SCHEMA schema_name
    | <schema action> [, ...] [ON SCHEMA schema_name]
<schema action> ::=
    CONTROL SCHEMA
    | CREATE TABLE
    | ALTER TABLE
    | DROP TABLE
    | SELECT TABLE
    | INSERT TABLE
    | DELETE TABLE
    | UPDATE TABLE
    | LOCK TABLE
    | CREATE VIEW
    | DROP VIEW
    | CREATE SEQUENCE
    | ALTER SEQUENCE
    | DROP SEQUENCE
    | USAGE SEQUENCE
    | CREATE INDEX
    | ALTER INDEX
    | DROP INDEX
    | ADD CONSTRAINT
    | CREATE SYNONYM
    | DROP SYNONYM
    | CREATE PROCEDURE
    | ALTER PROCEDURE
    | DROP PROCEDURE
    | EXECUTE PROCEDURE
    | CREATE PACKAGE
    | ALTER PACKAGE
    | DROP PACKAGE
    | EXECUTE PACKAGE
```

```

<table privilege> ::=
    ALL [ PRIVILEGES ] ON [TABLE] table_name
    | { <table action> | <column action> } [, ...] ON [TABLE] table_name
<table action> ::=
    CONTROL TABLE
    | SELECT
    | INSERT
    | UPDATE
    | DELETE
    | REFERENCES
    | LOCK
    | INDEX
    | ALTER
<column action> ::=
    SELECT ( column_name [, ...] )
    | INSERT ( column_name [, ...] )
    | UPDATE ( column_name [, ...] )
    | REFERENCES ( column_name [, ...] )
<sequence privilege> ::=
    ALL [ PRIVILEGES ] ON SEQUENCE sequence_name
    | <sequence action> ON SEQUENCE sequence_name
<sequence action> ::=
    USAGE
<procedure privilege> ::=
    ALL [ PRIVILEGES ] ON PROCEDURE procedure_name
    | <procedure action> ON PROCEDURE procedure_name
<procedure action> ::=
    EXECUTE
<package privilege> ::=
    ALL [ PRIVILEGES ] ON PACKAGE package_name
    | <package action> ON PACKAGE package_name
<package action> ::=
    EXECUTE

```

## Syntax Rules and Parameters

## <grantee>

It is the user to be granted the privileges.

- user\_identifier
  - It grants the privilege to a user.
- PUBLIC
  - It is an authorization object which means all users.

## WITH GRANT OPTION

It allows the grantee to grant the privilege to other users.

When the same <privilege> is granted as follows, WITH GRANT OPTION is maintained.

- GRANT SELECT ON t1 TO u1 WITH GRANT OPTION;
- GRANT SELECT ON t1 TO u1;

## <privilege>

It is a privilege which is to be granted to a grantee (the user to be granted the privilege).

The grantor (the user to perform the statement) should satisfy one of the following conditions.

- The grantor owns that <privilege> by using WITH GRANT OPTION.
  - The grantor is the user who performs the statement.
- The grantor owns the ACCESS CONTROL ON DATABASE privilege.
  - The grantor is the object owner.
    - <database privilege>: \_SYSTEM account
    - <tablespace privilege>: \_SYSTEM account
    - <schema privilege>: \_SYSTEM account
    - <table privilege>: The owner of the table
    - <sequence privilege>: The owner of the sequence
    - <procedure privilege>: The owner of the procedure/function
    - <package privilege>: The owner of the package

## <database privilege>

It is the privilege for the database objects.

[ON DATABASE] statement can be omitted.

The database action which can be defined with the database privilege is as follows.

- ALL [ PRIVILEGES ] [ ON DATABASE]
  - All privileges for the database which the grantor (the user who performs the statement) owns by using WITH GRANT OPTION.

**Table 19-29** Database privilege

<database action>	Description
ADMINISTRATION	Privilege for starting or terminating the server
ALTER DATABASE	Privilege for executing ALTER DATABASE
ALTER SYSTEM	Privilege for executing ALTER SYSTEM
AUDIT SYSTEM	Privilege for controlling the audit policy
ACCESS CONTROL	Privilege for controlling all the privileges
CREATE SESSION	Privilege for connecting to the database
CREATE PROFILE	Privilege for creating profiles in the database
ALTER PROFILE	Privilege for altering any profile in the database
DROP PROFILE	Privilege for dropping any profile in the database
CREATE USER	Privilege for creating users in the database
ALTER USER	Privilege for altering any user in the database
DROP USER	Privilege for dropping any user in the database
CREATE ROLE	Privilege for creating roles in the database
ALTER ROLE	Privilege for altering any role in the database
DROP ROLE	Privilege for dropping any role in the database
CREATE TABLESPACE	Privilege for creating tablespaces in the database
ALTER TABLESPACE	Privilege for altering any tablespace in the database
DROP TABLESPACE	Privilege for dropping any tablespace in the database
USAGE TABLESPACE	Privilege for using any tablespace in the database
CREATE SCHEMA	Privilege for creating schemas in the database
ALTER SCHEMA	Privilege for altering any schema in the database
DROP SCHEMA	Privilege for dropping any schema in the database
CREATE PUBLIC SYNONYM	Privilege for creating public synonyms in the database
DROP PUBLIC SYNONYM	Privilege for dropping any public synonym in the database
CREATE ANY TABLE	Privilege for creating tables in any schema of the database
ALTER ANY TABLE	Privilege for altering any table in the database
DROP ANY TABLE	Privilege for dropping any table in the database
SELECT ANY TABLE	Privilege for querying rows of any table in the database
INSERT ANY TABLE	Privilege for creating rows of any table in the database
DELETE ANY TABLE	Privilege for deleting rows of any table in the database
UPDATE ANY TABLE	Privilege for updating rows of any table in the database
LOCK ANY TABLE	Privilege for locking any table in the database
CREATE ANY VIEW	Privilege for creating views in any schema of the database

⟨database action⟩	Description
DROP ANY VIEW	Privilege for dropping any view in the database
CREATE ANY SEQUENCE	Privilege for creating sequences in any schema of the database
ALTER ANY SEQUENCE	Privilege for altering any sequence of the database
DROP ANY SEQUENCE	Privilege for dropping any sequence of the database
USAGE ANY SEQUENCE	Privilege for using any sequence of the database
CREATE ANY INDEX	Privilege for creating indexes in any schema of the database
ALTER ANY INDEX	Privilege for altering any index in the database
DROP ANY INDEX	Privilege for dropping any index in the database
CREATE ANY SYNONYM	Privilege for creating synonyms in the database
DROP ANY SYNONYM	Privilege for dropping any synonym in the database
CREATE ANY PROCEDURE	Privilege for creating any procedure/function in any schema of the database
ALTER ANY PROCEDURE	Privilege for altering any procedure/function in the database
DROP ANY PROCEDURE	Privilege for dropping any procedure/function in the database
EXECUTE ANY PROCEDURE	Privilege for executing any procedure/function in the database
CREATE ANY PACKAGE	Privilege for creating any package in any schema of the database
ALTER ANY PACKAGE	Privilege for altering any package in the database
DROP ANY PACKAGE	Privilege for dropping any package in the database
EXECUTE ANY PACKAGE	Privilege for executing any package in the database
PURGE DBA_RECYCLEBIN	Privilege for dropping any package in the database

## ⟨tablespace privilege⟩

It is the privilege for the tablespace objects.

The tablespace action which can be defined with the tablespace privilege is as follows.

- ALL [ PRIVILEGES ] ON TABLESPACE tablespace\_name
  - All privileges for the tablespace which the grantor (the user who performs the statement) owns by using WITH GRANT OPTION.

**Table 19-30** Tablespace privilege

⟨tablespace action⟩	Description
CREATE OBJECT	Privilege for creating objects in the tablespace

## ⟨schema privilege⟩

It is the privilege for the schema objects.

- Whether to omit [ON SCHEMA schema\_name]

- If multiple <grantee> exist, [ON SCHEMA schema\_name] statement can not be omitted.
- If ALL [PRIVILEGES] is used, [ON SCHEMA schema\_name] statement can not be omitted.
- If [ON SCHEMA schema\_name] statement is omitted, <grantee> can use only one user\_identifier, and the privilege on the first schema in the schema search path of <grantee> is granted.

The schema action which can be defined with the schema privilege is as follows.

- ALL [ PRIVILEGES ] ON SCHEMA schema\_name
  - All privileges for the schema which the grantor (the user who performs the statement) owns by using WITH GRANT OPTION

**Table 19-31** Schema privilege

<schema action>	Description
CONTROL SCHEMA	All privileges for that schema
CREATE TABLE	Privilege for creating tables in the schema
ALTER TABLE	Privilege for altering any table in the schema
DROP TABLE	Privilege for dropping any table in the schema
SELECT TABLE	Privilege for querying rows of any table in the schema
INSERT TABLE	Privilege for creating rows of any table in the schema
DELETE TABLE	Privilege for deleting rows of any table in the schema
UPDATE TABLE	Privilege for updating rows of any table in the schema
LOCK TABLE	Privilege for locking any table of the schema
CREATE VIEW	Privilege for creating views in the schema
DROP VIEW	Privilege for dropping any view of the schema
CREATE SEQUENCE	Privilege for creating sequences in the schema
ALTER SEQUENCE	Privilege for altering any sequence of the schema
DROP SEQUENCE	Privilege for dropping any sequence of the schema
USAGE SEQUENCE	Privilege for using any sequence of the schema
CREATE INDEX	Privilege for creating indexes in the schema
ALTER INDEX	Privilege for altering any index in the schema
DROP INDEX	Privilege for dropping any index in the schema
ADD CONSTRAINT	Privilege for creating constraints in the schema
CREATE SYNONYM	Privilege for creating synonyms in the schema
DROP SYNONYM	Privilege for dropping any synonym of the schema
CREATE PROCEDURE	Privilege for creating any procedure/function in the schema
ALTER PROCEDURE	Privilege for altering any procedure/function in the schema
DROP PROCEDURE	Privilege for dropping any procedure/function in the schema
EXECUTE PROCEDURE	Privilege for executing any procedure/function in the schema
CREATE PACKAGE	Privilege for creating any package in the schema
ALTER PACKAGE	Privilege for altering any package in the schema
DROP PACKAGE	Privilege for dropping any package in the schema
EXECUTE PACKAGE	Privilege for executing any package in the schema



## <table privilege>

It is the privilege for the table object or the view object.

[TABLE] statement can be omitted.

The table action which can be defined with the table privilege is as follows.

- ALL [ PRIVILEGES ] ON [TABLE] table\_name
  - All privileges for the table which the grantor (the user who performs the statement) owns by using WITH GRANT OPTION

**Table 19-32** Table privilege

<table action>	Description
CONTROL TABLE	All privileges for that table
SELECT	Privilege for querying rows of the table
INSERT	Privilege for creating rows into the table
UPDATE	Privilege for updating rows in the table
DELETE	Privilege for deleting rows from the table
REFERENCES	Privilege for creating referential constraints which refers to the table
LOCK	Privilege for locking the table
INDEX	Privilege for creating indexes in the table
ALTER	Privilege for altering the table

For SELECT, INSERT, UPDATE, REFERENCES, additional privileges are granted to all columns of the table.

The column action which can be defined with the table privilege is as follows. However, the column action is applicable only to the base table.

**Table 19-33** Column privilege

<column action>	Description
SELECT (columns)	Privilege for querying that columns
INSERT (columns)	Privilege for creating rows including that columns
UPDATE (columns)	Privilege for updating that columns
REFERENCES (columns)	Privilege for creating referential constraints which refers to that columns

## <sequence privilege>

It is the privilege for the sequence object.

The sequence action which can be defined with the sequence privilege is as follows.

- ALL [ PRIVILEGES ] ON SEQUENCE sequence\_name

- All privileges for the sequence which the grantor (the user who performs the statement) owns by using WITH GRANT OPTION.

**Table 19-34** Sequence privilege

⟨sequence action⟩	Description
USAGE	Privilege for using the sequence

## ⟨procedure privilege⟩

It is the privilege for the procedure/ function object.

The action which can be defined with the procedure privilege is as follows.

- ALL [ PRIVILEGES ] ON PROCEDURE procedure\_name
  - All privileges for the procedure/ function which the grantor (the user who performs the statement) owns by using WITH GRANT OPTION

**Table 19-35** Procedure privilege

⟨procedure action⟩	Description
EXECUTE	Privilege for executing the procedure/function

## ⟨package privilege⟩

It is the privilege for the package object.

The action which can be defined with the package privilege is as follows.

- ALL [ PRIVILEGES ] ON PACKAGE package\_name
  - All privileges for the package which is given to the grantor (the user who performs the statement) by using WITH GRANT OPTION

**Table 19-36** Package privilege

⟨package action⟩	Description
EXECUTE	Privilege for executing the package

## Description

Data Definition Language (DDL) such as GRANT privilege can be rolled back if it is before when the transaction is committed.

The owner who created SQL schema object, such as table, sequence, has certain privileges without being granted any separate privilege for the object.

For more information, refer to the following CREATE statements.

- CREATE TABLE
- CREATE VIEW
- CREATE SEQUENCE
- ALTER TABLE name ADD COLUMN
- CREATE FUNCTION
- CREATE PROCEDURE
- CREATE PACKAGE

The owner who created non-schema object such as schema, tablespace, does not automatically have any privilege for the object. Therefore, the privilege should be separately granted.

For more information, refer to the following CREATE statements.

- CREATE SCHEMA
- CREATE TABLESPACE
- CREATE USER

## Examples

The following is an example of granting SELECT ON TABLE t1 privilege to the user u1.

```
gSQL> GRANT SELECT ON t1 TO u1;  
Grant succeeded.
```

The following is an example of granting SELECT ON TABLE t1 privilege to the PUBLIC account (all users).

```
gSQL> GRANT SELECT ON t1 TO PUBLIC;  
Grant succeeded.
```

The following is an example that the user u1 grants the privilege to the other user by using WITH GRANT OPTION.

```
gSQL> GRANT SELECT ON t1 TO u1 WITH GRANT OPTION;  
Grant succeeded.
```

The following is the example that the user executing the statement grants all privileges on the TABLE t1 to user u1 by using WITH GRANT OPTION.

```
gSQL> GRANT ALL PRIVILEGES ON TABLE t1 TO u1;  
Grant succeeded.
```

The following is an example of granting CREATE SESSION ON DATABASE privilege which is a privilege for connecting to the database.

```
gSQL> GRANT CREATE SESSION ON DATABASE TO u1;  
Grant succeeded.
```

The following is an example of granting multiple privileges for creating objects such as the table, view, index, sequence, constraint in the SCHEMA s1 to the user u1.

```
gSQL> GRANT CREATE TABLE, CREATE VIEW, CREATE INDEX, CREATE SEQUENCE, ADD CONSTRAINT ON SCHEMA  
s1 TO u1;  
Grant succeeded.
```

The following is an example of granting the privileges for creating objects in TABLESPACE mem\_data\_tb to the user u1.

```
gSQL> GRANT CREATE OBJECT ON TABLESPACE mem_data_tbs TO u1;  
Grant succeeded.
```

The following is an example of granting the privilege for querying some columns in the TABLE t1 to the user u1.

```
gSQL> GRANT SELECT( id, name ) ON TABLE t1 TO u1;  
Grant succeeded.
```

The following is an example of granting the privilege to the user u1 for using NEXTVAL(), CURRVAL() functions in the SEQUENCE seq1.

```
gSQL> GRANT USAGE ON SEQUENCE seq1 TO u1;  
Grant succeeded.
```

## Compatibility

The SQL standard does not define the following privileges.

- <database privilege>
- <tablespace privilege>
- <schema privilege>

**Table 19-37** SQL standard compatibility

Feature ID	Description	Compatibility
S023	Basic structured types	X
S024	Enhanced structured types	X
S081	Subtables	X
T211	Basic trigger capability	X
T281	SELECT privilege with column granularity	O
T332	Extended Roles	X
F731	INSERT column privileges	O

## For More Information

Refer to the followings.

- REVOKE privileges FROM
- CREATE USER
- DROP USER
- ALTER USER



**20.**

---

**SQL References (H~Z)**

## 20.1 INSERT INTO

### Function

It creates new rows in a table.

### Syntax

```

<insert statement> ::=
    INSERT INTO table_name [ ( column_name [, ...] ) ]
        <insert source>
    ;
<insert source> ::=
    <values clause>
  | <from subquery>
  | <from default>
<values clause> ::=
    VALUES { ( { <value expression> | DEFAULT } [, ...] ) } [, ...]
<from subquery> ::=
    <query expression>
<from default> ::=
    DEFAULT VALUES

```

### Invocation and Access Rules

A user should satisfy the following conditions to perform <Insert statement>.

- One of the following privileges is required to perform the INSERT statement.
  - INSERT(columns) ON TABLE for all columns which are targets of insert
  - (INSERT or CONTROL TABLE) ON TABLE for the table
  - (INSERT TABLE or CONTROL SCHEMA) ON SCHEMA for the schema to which the table belongs
  - INSERT ANY TABLE ON DATABASE
- One of the following privileges is required for all tables used in <from subquery>.
  - SELECT(columns) ON TABLE for all columns of tables which were used in the statement
  - (SELECT or CONTROL TABLE) ON TABLE for the table



- (SELECT TABLE or CONTROL SCHEMA) ON SCHEMA for the schema to which the table belongs
- SELECT ANY TABLE ON DATABASE

## Syntax Rules and Parameters

### table\_name

It is the name of a target table in which the row is to be created.

It can define schema to which the table belongs such as schema\_name.table\_name and if schema\_name is omitted, the default schema name of the user performing the statement is used.

### [ ( column\_name [, ...] ) ]

It is the column name of a table.

The column list can be omitted.

The number of columns and the number of <insert source> values should be same, and DEFAULT value is assigned to the omitted column.

### <values clause>

It is the list of values to be assigned to the corresponding columns.

- <value expression>
  - It is the value or expression to be assigned to the corresponding column.
- DEFAULT
  - The value of corresponding column will use the default value which were defined through **CREATE TABLE**.
  - If it is not defined, NULL will be assigned.

Multiple rows can be created as follows.

```
INSERT INTO table_name VALUES ( 1, 'A' ), ( 2, 'B' ), ( 3, 'C' )
```

### <from subquery>

It is the query to create rows.

For more information, refer to **query expression** clause of **SELECT** statement.

## DEFAULT VALUES

It fills every column with default value.

DEFAULT VALUES clause means as same as the following.

```
VALUES ( DEFAULT, DEFAULT, ..., DEFAULT )
```

## Description

### Differences among INSERT-related Statements

- **INSERT INTO**
  - It creates one or multiple rows into the table.
  - e.g. INSERT INTO t1 SELECT \* FROM t1;
- **INSERT INTO name RETURNING**
  - It creates one or multiple rows into the table, then the created rows can be retrieved in the same way as SELECT statement(API such as SQLFetch()).
  - e.g. INSERT INTO t1 SELECT \* FROM t1 RETURNING c1;
- **INSERT INTO name RETURNING .. INTO**
  - It creates one or less row, and if a single row is created, it obtains the value to the host variable of RETURNING INTO clause.
  - e.g. INSERT INTO t1 DEFAULT VALUES RETURNING c1 INTO :v1;

## Examples

The following is an example of creating a single row by using INSERT statement.

```
gSQL> INSERT INTO region VALUES ( 0, 'AFRICA' );
1 row created.
```

The following is an example of using the DEFAULT value or identity value of the column in INSERT statement.

```
gSQL> CREATE TABLE region
(
    r_regionkey    BIGINT    GENERATED BY DEFAULT AS IDENTITY
, r_name         CHAR(25)  DEFAULT 'N/A'
);
```

```
Table created.
gSQL> COMMIT;
Commit complete.
```

- DEFAULT is inserted into all columns.

```
gSQL> INSERT INTO region DEFAULT VALUES;
1 row created.
```

- DEFAULT is inserted into all columns.

```
gSQL> INSERT INTO region VALUES (DEFAULT, DEFAULT);
1 row created.
```

- If a column is omitted, the DEFAULT value of r\_name column is used.

```
gSQL> INSERT INTO region(r_regionkey) VALUES (-100);
1 row created.
```

- If a column is omitted, the identity value of r\_regionkey column is used.

```
gSQL> INSERT INTO region(r_name) VALUES ('ASIA');
1 row created.
```

```
gSQL> SELECT * FROM region;
```

```
R_REGIONKEY R_NAME
-----
          1 N/A
          2 N/A
        -100 N/A
          3 ASIA
```

```
4 rows selected.
```

The following is an example of creating multiple rows by describing them in VALUES clause.

```
gSQL> INSERT INTO region
      VALUES ( 1, 'AFRICA' ),
             ( 2, 'ASIA'   ),
             ( 3, 'EUROPE' );
3 rows created.
```

The following is an example of creating multiple rows by using a subquery.

```
gSQL> INSERT INTO region SELECT r_regionkey, r_name FROM tmp_region WHERE r_regionkey < 3;  
3 rows created.
```

## Compatibility

Table 20-1 SQL standard compatibility

Feature ID	Description	Compatibility
F781	Self-referencing operations	X
F222	INSERT statement: DEFAULT VALUES clause	O
S204	Enhanced structured types	X
S043	Enhanced reference types	X
T111	Updatable joins, unions, and columns	X

## For More Information

Refer to the followings.

- **SELECT**
- **INSERT INTO name RETURNING**
- **INSERT INTO name RETURNING .. INTO**

## 20.2 INSERT INTO name RETURNING

### Function

It creates new rows in the table, and retrieves them.

### Syntax

```

<insert statement> ::=
    INSERT INTO table_name [ ( column_name [, ...] ) ]
        <insert source>
        <returning clause>
    ;
<insert source> ::=
    <values clause>
    | <from subquery>
    | <from default>
<values clause> ::=
    VALUES { ( { <value expression> | DEFAULT } [, ...] ) } [, ...]
<from subquery> ::=
    <query expression>
<from default> ::=
    DEFAULT VALUES
<returning clause> ::=
    [ RETURN | RETURNING ] { * | { <value expression> [ [AS] alias_name ] } [, ...]

```

### Invocation and Access Rules

A user should satisfy the following conditions to perform <insert returning query statement>.

- One of the following privileges is required to perform INSERT statement.
  - INSERT(columns) ON TABLE for all columns which are targets of insert
  - (INSERT or CONTROL TABLE) ON TABLE for the table
  - (INSERT TABLE or CONTROL SCHEMA) ON SCHEMA for the schema to which the table belongs
  - INSERT ANY TABLE ON DATABASE

- One of the following privileges is required for all tables used in `<from subquery>`.
  - `SELECT(columns) ON TABLE` for all columns of tables which were used in the statement
  - `(SELECT or CONTROL TABLE) ON TABLE` for the table
  - `(SELECT TABLE or CONTROL SCHEMA) ON SCHEMA` for the schema to which the table belongs
  - `SELECT ANY TABLE ON DATABASE`
- One of the following privileges is required for all columns used in `RETURNING` clause.
  - `SELECT(columns) ON TABLE` for all columns which were used in `RETURNING` clause.
  - `(SELECT or CONTROL TABLE) ON TABLE` for the table
  - `(SELECT TABLE or CONTROL SCHEMA) ON SCHEMA` for the schema to which the table belongs
  - `SELECT ANY TABLE ON DATABASE`

## Syntax Rules and Parameters

### `table_name`

It is the name of a target table in which the row is to be created.

### `[ ( column_name [, ...] ) ]`

It is the column name of a table.

For more information, refer to **INSERT INTO**.

### `<values clause>`

It is the list of values to be assigned to the corresponding columns.

For more information, refer to **INSERT INTO**.

### `<from subquery>`

It is the query to create rows.

For more information, refer to **INSERT INTO**.

## DEFAULT VALUES

It fills every column with default value.

For more information, refer to **INSERT INTO**.

## <returning clause>

It returns the inserted rows.

- It sets the inserted rows as a result set, and specifies the rows to be retrieved.
  - RETURNING clause returns the rows which were inserted by INSERT statement, and which is a result set.
  - <value expression>
    - It is as same as <select list> in SELECT statement, but it can not use the aggregation.
  - [[AS] alias\_name]
    - It can name a value expression by using AS clause.

The keywords RETURNING and RETURN have the same meaning.

## Description

For more information, refer to [Differences among INSERT-related Statements](#).

## Examples

The following is an example of retrieving the column values created by using INSERT statement.

```
gSQL> CREATE TABLE region
(
  r_regionkey  BIGINT    GENERATED BY DEFAULT AS IDENTITY
, r_name      CHAR(25)  DEFAULT 'N/A'
);
Table created.
gSQL> COMMIT;
Commit complete.
```

- The following is an example of returning the created DEFAULT value (RETURNING).

```
gSQL> INSERT INTO region VALUES ( DEFAULT, DEFAULT ) RETURNING r_regionkey, r_name;
R_REGIONKEY R_NAME
-----
          1 N/A
1 row created.
```

- The following is an example of returning the omitted column value (RETURNING).

```
gSQL> INSERT INTO region(r_name) VALUES ('ASIA') RETURNING r_regionkey;
R_REGIONKEY
-----
          2
1 row created.
```

The following is an example of retrieving the rows created by using the subquery.

```
gSQL> INSERT INTO region
      SELECT r_regionkey, r_name FROM tmp_region WHERE r_regionkey < 3
      RETURNING r_regionkey, r_name;
R_REGIONKEY R_NAME
-----
          0 AFRICA
          1 AMERICA
          2 ASIA
3 rows created.
```

## Compatibility

The SQL standard does not define <insert returning query statement>.

## For More Information

Refer to the followings.

- INSERT INTO**
- INSERT INTO name RETURNING .. INTO**



## 20.3 INSERT INTO name RETURNING .. INTO

### Function

It creates a single row in a table, and obtains the value of the created row into a host variable.

### Syntax

```

<insert statement> ::=
    INSERT INTO table_name [ ( column_name [, ...] ) ]
        <insert source>
        <returning into clause>
    ;
<insert source> ::=
    <values clause>
    | <from subquery>
    | <from default>
<values clause> ::=
    VALUES { ( { <value expression> | DEFAULT } [, ...] ) } [, ...]
<from subquery> ::=
    <query expression>
<from default> ::=
    DEFAULT VALUES
<returning into clause> ::=
    [ RETURN | RETURNING ] { * | { <value expression> [ [AS] alias_name ] } [, ...] INTO
variable_name [, ...]

```

### Invocation and Access Rules

A user should satisfy the following conditions to perform <insert returning into statement>.

- One of the following privileges is required to perform INSERT statement.
  - INSERT(columns) ON TABLE for all columns which are targets of insert.
  - (INSERT or CONTROL TABLE) ON TABLE for the table
  - (INSERT TABLE or CONTROL SCHEMA) ON SCHEMA for the schema to which the table belongs

- INSERT ANY TABLE ON DATABASE
- One of the following privileges is required for all tables used in <from subquery>.
  - SELECT(columns) ON TABLE for all columns of tables which were used in the statement
  - (SELECT or CONTROL TABLE) ON TABLE for the table
  - (SELECT TABLE or CONTROL SCHEMA) ON SCHEMA for the schema to which the table belongs
  - SELECT ANY TABLE ON DATABASE
- One of the following privileges is required for all columns used in RETURNING clause.
  - SELECT(columns) ON TABLE for all columns which were used in RETURNING clause
  - (SELECT or CONTROL TABLE) ON TABLE for the table
  - (SELECT TABLE or CONTROL SCHEMA) ON SCHEMA for the schema to which the table belongs
  - SELECT ANY TABLE ON DATABASE

## Syntax Rules and Parameters

### table\_name

It is the name of a target table in which the row is to be created.

### [ ( column\_name [, ...] ) ]

It is the column name of a table.

For more information, refer to **INSERT INTO**.

### <values clause>

It is the list of values to be assigned to the corresponding columns.

For more information, refer to **INSERT INTO**.

### <from subquery>

It is the query to create rows.

For more information, refer to **INSERT INTO**.

## DEFAULT VALUES

It fills every column with default value.

For more information, refer to **INSERT INTO**.

## ⟨returning clause⟩

It returns the inserted rows.

For more information, refer to ⟨returning clause⟩ in **INSERT INTO name RETURNING** statement.

## INTO variable\_name [, ...]

The number of variables in INTO clause should be equal to the number of the expressions in RETURNING clause.

The row to be created should be one or less. If two or more rows are created, an error occurs.

## Description

For more information, refer to **Differences among INSERT-related Statements**.

## Example

The following is an example of obtaining the value of the created row into a host variable.

```
gSQL> CREATE TABLE region
(
  r_regionkey  BIGINT    GENERATED BY DEFAULT AS IDENTITY
, r_name      CHAR(25)  DEFAULT 'N/A'
);
Table created.
gSQL> COMMIT;
Commit complete.
```

- The host variables are declared.

```
\VAR v_key  BIGINT
\VAR v_name VARCHAR(128)
```

- The created DEFAULT values are obtained into the host variables.

```
gSQL> INSERT INTO region
      VALUES ( DEFAULT, DEFAULT )
      RETURNING r_regionkey, r_name
      INTO :v_key, :v_name;
V_KEY V_NAME
-----
      1 N/A
1 row created.
```

- The omitted column value is obtained into the host variable.

```
gSQL> INSERT INTO region(r_name)
      VALUES ('ASIA')
      RETURNING r_regionkey
      INTO :v_key;
V_KEY
-----
      2
1 row created.
```

## Compatibility

The SQL standard does not define <insert returning into statement>.

## For More Information

Refer to the followings.

- **INSERT INTO**
- **INSERT INTO name RETURNING**

## 20.4 INSERT INTO name ... UPDATE

### Function

It creates new rows in a table. If it violates the unique constraint, then it updates the existing rows.

### Syntax

```

<upsert statement> ::=
    INSERT INTO table_name [ ( column_name [, ...] ) ]
        <insert source>
        <duplicate key clause>
    ;
<insert source> ::=
    <values clause>
    | <from subquery>
    | DEFAULT VALUES
<values clause> ::=
    VALUES { ( { <value expression> | DEFAULT } [, ...] ) } [, ...]
<from subquery> ::=
    <query expression>
<duplicate key clause>
    ON DUPLICATE KEY { DO NOTHING | <do update clause> }
<do update clause> ::=
    [DO] UPDATE [SET] <set clause> [, ...]
<set value clause> ::=
    <value expression>
    | DEFAULT
    | VALUES( column_name )
<set clause> ::=
    column_name = <set value clause>
    | ( column_name [, ...] ) = ( <set value clause> [, ...] )
    | ( column_name [, ...] ) = ( <query expression> )

```

## Invocation and Access Rules

A user should satisfy the following conditions to perform `<upsert statement>`.

- One of the following privileges is required to perform the corresponding statement.
  - `INSERT(columns) ON TABLE` for all columns which are targets of insert
  - `(INSERT or CONTROL TABLE) ON TABLE` for the table
  - `(INSERT TABLE or CONTROL SCHEMA) ON SCHEMA` for the schema to which the table belongs
  - `INSERT ANY TABLE ON DATABASE`
  - `UPDATE(columns) ON TABLE` for all columns which are targets of update
  - `(UPDATE or CONTROL TABLE) ON TABLE` for the table
  - `(UPDATE TABLE or CONTROL SCHEMA) ON SCHEMA` for the schema to which the table belongs
  - `UPDATE ANY TABLE ON DATABASE`
- One of the following privileges is required for all tables used in `<from subquery>`.
  - `SELECT(columns) ON TABLE` for all columns of tables which were used in the statement
  - `(SELECT or CONTROL TABLE) ON TABLE` for the table
  - `(SELECT TABLE or CONTROL SCHEMA) ON SCHEMA` for the schema to which the table belongs
  - `SELECT ANY TABLE ON DATABASE`
- One of the following privileges is required for all columns used in `RETURNING` clause.
  - `SELECT(columns) ON TABLE` for all columns which were used in `RETURNING` clause
  - `(SELECT or CONTROL TABLE) ON TABLE` for the table
  - `(SELECT TABLE or CONTROL SCHEMA) ON SCHEMA` for the schema to which the table belongs
  - `SELECT ANY TABLE ON DATABASE`

## Syntax Rules and Parameters

### `table_name`

It is the name of a target table in which the row is to be created.

Or, it is the name of a target table to be updated when they are updated because it violates the unique constraint.

It can define schema to which the table belongs such as `schema_name.table_name` and if `schema_name` is omitted, the default schema name of the user performing the statement is used.

## [ ( column\_name [, ...] ) ]

It is the column name of a table.

For more information, refer to [ ( column\_name [, ...] ) ] clause of **INSERT INTO** statement.

## <values clause>

It is the list of values to be assigned to the corresponding columns.

For more information, refer to <values clause> of **INSERT INTO** statement.

## <from subquery>

It is the query to create rows.

For more information, refer to **query expression** clause of **SELECT** statement.

## DEFAULT VALUES

It fills every column with default value.

For more information, refer to **DEFAULT VALUES** clause of **INSERT INTO** statement.

## <duplicate key clause>

It defines the action to perform when it violates the unique constraint.

## DO NOTHING

It does not perform any operation when it violates the unique constraint.

## <do update clause>

It updates the values in columns according to <set clause> when it violates the unique constraint.

## <set value clause>

It defines the values to assign to the columns to be updated.

It can be defined as follows.

- column\_name = <value expression>

```
DO UPDATE SET column1 = value1, column2 = value2, column3 = value3
```

- column\_name = DEFAULT

```
DO UPDATE SET column1 = DEFAULT, column2 = DEFAULT, column3 = DEFAULT
```

- column\_name = VALUES( column\_name )

<insert source> value is used to update the value.

```
DO UPDATE SET column1 = VALUES(column1), column2 = VALUES(column2), column3 = VALUES(column2)
```

## <set clause>

It defines the columns to be updated and the values to be assigned, and the number of columns in <set clause> and the number of values should be same.

It can be defined as follows.

- column\_name = { <set value clause> }

```
ON DUPLICATE KEY
```

```
DO UPDATE SET column1 = value1, column2 = value2, column3 = value3
```

- ( column\_name [, ...] ) = ( <set value clause> } [, ...] )

```
ON DUPLICATE KEY
```

```
DO UPDATE SET ( column1, column2, column3 ) = ( value1, value2, value3 )
```

- ( column\_name [, ...] ) = ( <query expression> )

```
ON DUPLICATE KEY
```

```
DO UPDATE SET column1 = ( SELECT max(value1) FROM other_table_name )
```

<query expression> should be a query creating a single row.

If DEFAULT is used as a column value, it uses the default value (refer to <default clause>.) defined when performing CREATE TABLE, and NULL value is assigned when it is not defined.



## Description

### Differences among INSERT INTO name ... UPDATE-related Statements

- **INSERT INTO name ... UPDATE**
  - It creates rows in a table. If it violates the unique constraint, then it updates the existing rows.
  - e.g. `INSERT INTO t1 VALUES ( 1, 1 ) ON DUPLICATE KEY UPDATE c2 = c2 + 1;`
- **INSERT INTO name ... UPDATE RETURNING**
  - It creates rows in a table or updates the existing rows. The inserted rows or the updated rows can be retrieved in the same way as SELECT statement (API such as SQLFetch()).
  - e.g. `INSERT INTO t1 VALUES ( 1, 1 ) ON DUPLICATE KEY UPDATE c2 = c2 + 1 RETURNING c2;`
- **INSERT INTO name ... UPDATE RETURNING ... INTO**
  - It creates or updates one or less row. If the created row or the updated row is a single row, then it obtains the value into a host variable of RETURNING INTO clause.
  - e.g. `INSERT INTO t1 VALUES ( 1, 1 ) ON DUPLICATE KEY UPDATE c2 = c2 + 1 RETURNING c2 INTO :v1;`

### <upsert statement> is a deterministic statement.

The results of the two equivalent and different UPSERT statements should be same as follows.

- `INSERT INTO t1 VALUES( 1 ),( 2 ),( 3 ) ON DUPLICATE KEY UPDATE c1 = c1 + 1;`
- `INSERT INTO t1 VALUES( 3 ),( 2 ),( 1 ) ON DUPLICATE KEY UPDATE c1 = c1 + 1;`

```
gSQL> CREATE TABLE t1 ( c1 INTEGER UNIQUE );
Table created.
gSQL> INSERT INTO t1 VALUES( 1 ),( 2 ),( 3 );
3 rows created.
gSQL> INSERT INTO t1 VALUES( 1 ),( 2 ),( 3 ) ON DUPLICATE KEY UPDATE c1 = c1 + 1;
3 rows created.
gSQL> SELECT * FROM t1;
C1
--
 2
 3
 4
3 rows selected.
```

```
gSQL> CREATE TABLE t1 ( c1 INTEGER UNIQUE );
Table created.
gSQL> INSERT INTO t1 VALUES( 1 ),( 2 ),( 3 );
```

```

3 rows created.
gSQL> INSERT INTO t1 VALUES( 3 ),( 2 ),( 1 ) ON DUPLICATE KEY UPDATE c1 = c1 + 1;
3 rows created.
gSQL> SELECT * FROM t1;
C1
--
 2
 3
 4
3 rows selected.

```

## Examples

The following is an example of updating a single row because it violates the unique constraint.

```

gSQL> CREATE TABLE t1 ( c1 INTEGER UNIQUE );
Table created.
gSQL> INSERT INTO t1 VALUES( 1 );
1 row created.
gSQL> INSERT INTO t1 VALUES( 1 ) ON DUPLICATE KEY UPDATE c1 = c1 + 1;
1 row created.
gSQL> SELECT * FROM t1;
C1
--
 2
1 row selected.

```

The following is an example of not updating a row even when it violates the unique constraint.

```

gSQL> CREATE TABLE t1 ( c1 INTEGER UNIQUE );
Table created.
gSQL> INSERT INTO t1 VALUES( 1 );
1 row created.
gSQL> INSERT INTO t1 VALUES( 1 ) ON DUPLICATE KEY DO NOTHING;
no rows created.
gSQL> SELECT * FROM t1;
C1
--
 1
1 row selected.

```

The following is an example of inserting or updating multiple rows by using a subquery.

```
gSQL> CREATE TABLE t1 ( c1 INTEGER UNIQUE );
Table created.
gSQL> INSERT INTO t1 VALUES( 1 ),( 2 ),( 3 ),( 4 );
4 rows created.
gSQL> INSERT INTO t1 ( SELECT c1 FROM t1 ) ON DUPLICATE KEY UPDATE c1 = c1 + 1;
4 rows created.
gSQL> SELECT * FROM t1;
C1
--
 2
 3
 4
 5
4 rows selected.
```

## Compatibility

The SQL standard does not define <upsert statement>.

## For More Information

Refer to the followings.

- INSERT INTO
- INSERT INTO name ... UPDATE RETURNING
- INSERT INTO name ... UPDATE RETURNING ... INTO
- UPDATE

## 20.5 INSERT INTO name ... UPDATE RETURNING

### Function

It creates new rows in a table. If it violates the unique constraint, then it updates the existing rows. Then, it retrieves the created rows or the updated rows.

### Syntax

```

<upsert returning statement> ::=
    INSERT INTO table_name [ ( column_name [, ...] ) ]
        <insert source>
        <duplicate key clause>
        <returning clause>
    ;
<insert source> ::=
    <values clause>
    | <from subquery>
    | DEFAULT VALUES
<values clause> ::=
    VALUES { ( { <value expression> | DEFAULT } [, ...] ) } [, ...]
<from subquery> ::=
    <query expression>
<duplicate key clause>
    ON DUPLICATE KEY { DO NOTHING | <do update clause> }
<do update clause> ::=
    [DO] UPDATE [SET] <set clause> [, ...]
<set value clause> ::=
    <value expression>
    | DEFAULT
    | VALUES( column_name )
<set clause> ::=
    column_name = <set value clause>
    | ( column_name [, ...] ) = ( <set value clause> [, ...] )
    | ( column_name [, ...] ) = ( <query expression> )
<returning clause> ::=
    [ RETURN | RETURNING ] { * | { <value expression> [ [AS] alias_name ] } [, ...]

```

## Invocation and Access Rules

A user should satisfy the following conditions to perform `<upsert returning statement>`.

- One of the following privileges is required to perform the corresponding statement.
  - INSERT(columns) ON TABLE for all columns which are targets of insert
  - (INSERT or CONTROL TABLE) ON TABLE for the table
  - (INSERT TABLE or CONTROL SCHEMA) ON SCHEMA for the schema to which the table belongs
  - INSERT ANY TABLE ON DATABASE
  - UPDATE(columns) ON TABLE for all columns which are targets of update
  - (UPDATE or CONTROL TABLE) ON TABLE for the table
  - (UPDATE TABLE or CONTROL SCHEMA) ON SCHEMA for the schema to which the table belongs
  - UPDATE ANY TABLE ON DATABASE
- One of the following privileges is required for all tables used in `<from subquery>`.
  - SELECT(columns) ON TABLE for all columns of tables which were used in the statement
  - (SELECT or CONTROL TABLE) ON TABLE for the table
  - (SELECT TABLE or CONTROL SCHEMA) ON SCHEMA for the schema to which the table belongs
  - SELECT ANY TABLE ON DATABASE
- One of the following privileges is required for all columns used in RETURNING clause.
  - SELECT(columns) ON TABLE for all columns which were used in RETURNING clause
  - (SELECT or CONTROL TABLE) ON TABLE for the table
  - (SELECT TABLE or CONTROL SCHEMA) ON SCHEMA for the schema to which the table belongs
  - SELECT ANY TABLE ON DATABASE

## Syntax Rules and Parameters

### table\_name

It is the name of a target table in which the row is to be created.

Or, it is the name of a target table to be updated when they are updated because it violates the unique constraint.

For more information, refer to `table_name` clause of `INSERT INTO name ... UPDATE` statement.

**[ ( column\_name [, ...] ) ]**

It is the column name of a table.

For more information, refer to [ ( **column\_name** [, ...] ) ] clause of **INSERT INTO** statement.

### <values clause>

It is the list of values to be assigned to the corresponding columns.

For more information, refer to <values clause> of **INSERT INTO** statement.

### <from subquery>

It is the query to create rows.

For more information, refer to **query expression** clause of **SELECT** statement.

## DEFAULT VALUES

It fills every column with default value.

For more information, refer to **DEFAULT VALUES** clause of **INSERT INTO** statement.

### <duplicate key clause>

It defines the action to perform when it violates the unique constraint.

## DO NOTHING

It does not perform any operation when it violates the unique constraint.

### <do update clause>

It updates the values in columns according to <set clause> when it violates the unique constraint.

### <set value clause>

It defines the values to assign to the columns to be updated.

For more information, refer to <set value clause> of **INSERT INTO name ... UPDATE** statement.

## <set clause>

It defines the columns to be updated and the values to be assigned, and the number of columns in <set clause> and the number of values should be same.

For more information, refer to <set clause> of **INSERT INTO name ... UPDATE**.

## <returning clause>

It returns the inserted rows or the updated rows.

- It sets the created rows as a result set, and specifies the rows to be retrieved.
  - RETURNING clause returns the result which sets inserted rows or updated rows as a result set.
  - <value expression>
    - It is as same as <select list> in SELECT statement, but it can not use the aggregation.
  - [[AS] alias\_name]
    - It can name a value expression by using AS clause.

## Description

For more information, refer to **Differences among INSERT INTO name ... UPDATE-related Statements**.

The following is an example of inserting four rows, and returning the inserted results.

```
gSQL> CREATE TABLE t1 ( c1 INTEGER UNIQUE );
Table created.
gSQL> INSERT INTO t1 VALUES( 1 ), ( 2 ), ( 3 ), ( 4 ) ON DUPLICATE KEY UPDATE c1 = c1 + 1
RETURNING c1;
C1
--
1
2
3
4
4 rows created.
```

The following is an example of updating rows because it violates the unique constraint, and returning the updated results.

```
gSQL> CREATE TABLE t1 ( c1 INTEGER UNIQUE );
Table created.
```

```
gSQL> INSERT INTO t1 VALUES( 1 ),( 2 ),( 3 ),( 4 );
4 rows created.
gSQL> INSERT INTO t1 ( SELECT c1 FROM t1 ) ON DUPLICATE KEY UPDATE c1 = c1 + 1 RETURNING c1;
C1
--
 2
 3
 4
 5
4 rows created.
```

## Compatibility

The SQL standard does not define <upsert returning statement>.

## For More Information

Refer to the followings.

- **INSERT INTO name ... UPDATE**
- **INSERT INTO name ... UPDATE RETURNING ... INTO**



## 20.6 INSERT INTO name ... UPDATE RETURNING ... INTO

### Function

It creates a single row in a table. If it violates the unique constraint, then it updates the existing rows. Then, it obtains the created rows or the updated rows as the host variable.

### Syntax

```

<upsert returning into statement> ::=
    INSERT INTO table_name [ ( column_name [, ...] ) ]
        <insert source>
        <duplicate key clause>
        <returning clause>
        <into clause>
    ;
<insert source> ::=
    <values clause>
    | <from subquery>
    | DEFAULT VALUES
<values clause> ::=
    VALUES { ( { <value expression> | DEFAULT } [, ...] ) } [, ...]
<from subquery> ::=
    <query expression>
<duplicate key clause>
    ON DUPLICATE KEY { DO NOTHING | <do update clause> }
<do update clause> ::=
    [DO] UPDATE [SET] <set clause> [, ...]
<set value clause> ::=
    <value expression>
    | DEFAULT
    | VALUES( column_name )
<set clause> ::=
    column_name = <set value clause>
    | ( column_name [, ...] ) = ( <set value clause> [, ...] )

```

```

    | ( column_name [, ...] ) = ( <query expression> )
<returning clause> ::=
    [ RETURN | RETURNING ] { * | { <value expression> [ [AS] alias_name ] } [, ...]
<into clause> ::= INTO variable_name [, ...]

```

## Invocation and Access Rules

A user should satisfy the following conditions to perform <upsert returning into statement>.

- One of the following privileges is required to perform the corresponding statement.
  - INSERT(columns) ON TABLE for all columns which are targets of insert
  - (INSERT or CONTROL TABLE) ON TABLE for the table
  - (INSERT TABLE or CONTROL SCHEMA) ON SCHEMA for the schema to which the table belongs
  - INSERT ANY TABLE ON DATABASE
  - UPDATE(columns) ON TABLE for all columns which are targets of update
  - (UPDATE or CONTROL TABLE) ON TABLE for the table
  - (UPDATE TABLE or CONTROL SCHEMA) ON SCHEMA for the schema to which the table belongs
  - UPDATE ANY TABLE ON DATABASE
- One of the following privileges is required for all tables used in <from subquery>.
  - SELECT(columns) ON TABLE for all columns of tables which were used in the statement
  - (SELECT or CONTROL TABLE) ON TABLE for the table
  - (SELECT TABLE or CONTROL SCHEMA) ON SCHEMA for the schema to which the table belongs
  - SELECT ANY TABLE ON DATABASE
- One of the following privileges is required for all columns used in RETURNING clause.
  - SELECT(columns) ON TABLE for all columns which were used in RETURNING clause
  - (SELECT or CONTROL TABLE) ON TABLE for the table
  - (SELECT TABLE or CONTROL SCHEMA) ON SCHEMA for the schema to which the table belongs
  - SELECT ANY TABLE ON DATABASE

## Syntax Rules and Parameters

### table\_name

It is the name of a target table in which the row is to be created.

Or, it is the name of a target table to be updated when they are updated because it violates the unique constraint.

For more information, refer to **table\_name** clause of **INSERT INTO name ... UPDATE** statement.

## [ ( column\_name [, ...] ) ]

It is the column name of a table.

For more information, refer to [ ( column\_name [, ...] ) ] clause of **INSERT INTO** statement.

## <values clause>

It is the list of values to be assigned to the corresponding columns.

For more information, refer to <values clause> of **INSERT INTO** statement.

## <from subquery>

It is the query to create rows.

For more information, refer to **query expression** clause of **SELECT** statement.

## DEFAULT VALUES

It fills every column with default value.

For more information, refer to **DEFAULT VALUES** clause of **INSERT INTO** statement.

## <duplicate key clause>

It defines the action to perform when it violates the unique constraint.

## DO NOTHING

It does not perform any operation when it violates the unique constraint.

## <do update clause>

It updates the values in columns according to <set clause> when it violates the unique constraint.

## <set value clause>

It defines the values to assign to the columns to be updated.

For more information, refer to `<set value clause>` of `INSERT INTO name ... UPDATE` statement.

## `<set clause>`

It defines the columns to be updated and the values to be assigned, and the number of columns in `<set clause>` and the number of values should be same.

For more information, refer to `<set clause>` of `INSERT INTO name ... UPDATE`.

## `<returning clause>`

It returns the inserted rows or the updated rows.

For more information, refer to `<returning clause>` of `INSERT INTO name ... UPDATE RETURNING`.

## `<into clause>`

The number of variables specified in INTO clause should be same as the number of expressions specified in RETURNING clause.

The row should be created one or less. If two or more rows are created, then an error occurs.

## Description

For more information, refer to [Differences among INSERT INTO name ... UPDATE-related Statements](#).

The following is an example of inserting a single row, then obtaining the inserted result as the host variable.

```
gSQL> \VAR v_c1 INTEGER;
gSQL> CREATE TABLE t1 ( c1 INTEGER UNIQUE );
Table created.
gSQL> INSERT INTO t1 VALUES( 1 ) ON DUPLICATE KEY UPDATE c1 = c1 + 1 RETURNING c1 INTO :v_c1;
V_C1
----
  1
1 row created.
```

The following is an example of updating a single row because it violates the unique constraint, then obtaining the updated result as the host variable.

```
gSQL> \VAR v_c1 INTEGER;
gSQL> CREATE TABLE t1 ( c1 INTEGER UNIQUE );
Table created.
gSQL> INSERT INTO t1 VALUES( 1 );
1 row created.
gSQL> INSERT INTO t1 VALUES( 1 ) ON DUPLICATE KEY UPDATE c1 = c1 + 1 RETURNING c1 INTO :v_c1;
V_C1
----
    2
1 row created.
```

## Compatibility

The SQL standard does not define <upsert returning into statement>.

## For More Information

Refer to the followings.

- **INSERT INTO name ... UPDATE**
- **INSERT INTO name ... UPDATE RETURNING**

## 20.7 LOCK TABLE

### Function

It locks one or more tables.

### Syntax

```
<lock table statement> ::=
    LOCK TABLE lock target [, ...]
    IN <lock mode> MODE [<wait clause>]
    ;
<lock mode> ::=
    SHARE
    | EXCLUSIVE
    | ROW SHARE
    | ROW EXCLUSIVE
    | SHARE ROW EXCLUSIVE
<wait clause> ::=
    NOWAIT
    | WAIT time
```

### Invocation and Access Rules

One of the following privileges is required to perform <lock table statement>.

- (LOCK or CONTROL TABLE) ON TABLE for the table
- (LOCK TABLE or CONTROL SCHEMA) ON SCHEMA for the schema to which the table belongs
- LOCK ANY TABLE ON DATABASE

## Syntax Rules and Parameters

### <lock target>

It specifies the target table to be locked.

### <lock mode>

It specifies the LOCK mode.

- SHARE
  - It allows concurrent queries for the locked table, but prohibits updating the table.
- EXCLUSIVE
  - It allows exclusive queries for the locked table.
- ROW SHARE
  - It allows concurrent access to the locked table, but prohibits locking the entire table for exclusive access.
- ROW EXCLUSIVE
  - It allows concurrent access to the locked table, but prohibits locking the entire table for exclusive access.
  - If ROW EXCLUSIVE mode is set, it prohibits locking in SHARE mode.
  - ROW EXCLUSIVE mode is automatically obtained when updating, inserting, deleting.
- SHARE ROW EXCLUSIVE
  - It is used to search for the entire table or to make other users search for the rows in the table.
  - It prohibits other users from accessing the locked tables in SHARE mode or accessing the rows being updated.

### <wait clause>

It specifies the waiting time to acquire the lock.

- NOWAIT
  - It immediately acquires the lock control for the object.
  - If the lock is already set by another user, the control is immediately handed over.
    - In this case, the database generates a message.
- WAIT time
  - It sets the waiting time for acquiring the lock.
  - It is specified in seconds, and its value is from 0 to 1,000,000,000.
- If it is not specified, it waits indefinitely until acquiring the lock.

## Description

If the transaction is committed or rolled back all acquired locks are automatically released. When using `ROLLBACK TO SAVEPOINT` statement, all locks acquired since that savepoint are released.

## Examples

The following is an example of locking the TABLE t1 to prevent any updating operation by another transaction.

```
gSQL> LOCK TABLE t1 IN EXCLUSIVE MODE;  
Table locked.
```

The following is an example of performing LOCK statement for multiple tables.

```
gSQL> LOCK TABLE t1, t2 IN EXCLUSIVE MODE;  
Table locked.
```

The following is an example of acquiring SHARE ROW EXCLUSIVE lock for the TABLE t1.

```
gSQL> LOCK TABLE t1 IN SHARE ROW EXCLUSIVE MODE;  
Table locked.
```

The following statement is performed only when the lock can be immediately acquired for the table. If the lock can not be acquired, an error occurs.

```
gSQL> LOCK TABLE t1 IN EXCLUSIVE MODE NOWAIT;  
Table locked.
```

The following is an example of waiting 10 seconds to acquire the lock.

```
gSQL> LOCK TABLE t1 IN EXCLUSIVE MODE WAIT 10;  
Table locked.
```

## Compatibility

The SQL standard does not cover the concepts of the lock table.



## For More Information

Refer to the followings.

- COMMIT
- ROLLBACK

## 20.8 NOAUDIT POLICY

### Function

It deactivates the audit policy.

### Syntax

```
<noaudit policy statement> ::=  
    NOAUDIT POLICY policy_name  
    [ <specified_user_option> ]  
    ;  
<specified_user_option> ::=  
    BY user_name [, ...]
```

### Invocation and Access Rules

AUDIT SYSTEM ON DATABASE privilege is required to perform <noaudit policy statement>.

### Syntax Rules and Parameters

#### policy\_name

It is the name of the audit policy object to be deactivated.

The deactivated audit policy does not effect on the existing session, and it effects only on the newly created session.

#### <specified\_user\_option>

It specifies the user to be excluded from the auditing target.

Unlike AUDIT POLICY statement, NOAUDIT POLICY does not have EXCEPT option.

If AUDIT POLICY name BY clause is used, NOAUDIT POLICY name BY statement should be used to deactivate it.

If AUDIT POLICY name EXCEPT clause is used, NOAUDIT POLICY name statement without BY clause should be used to deactivate it.

NOAUDIT POLICY statement should be used as follows according to the usage of AUDIT POLICY statement to deactivate it.

**Table 20-2** Activating/ deactivating audit policy

Type	AUDIT POLICY statement	NOAUDIT POLICY statement
All users	AUDIT POLICY p1	NOAUDIT POLICY p1
Using BY	AUDIT POLICY p1 BY u1	NOAUDIT POLICY p1 BY u1
Using EXCEPT	AUDIT POLICY p1 EXCEPT u1	NOAUDIT POLICY p1

When deactivating all activated users, the audit policy object is completely deactivated.

## Description

The information about activation of the audit policy object is retrieved as follows.

```
SELECT policy_name
       , enabled_opt
       , user_name
FROM   audit_policy_enabled
WHERE  policy_name = 'P1';
```

NOAUDIT POLICY statement deletes each created information about activation according to the AUDIT POLICY specifying method.

If the information activated through the query above does not exist, then the audit policy is completely deactivated.

If all users are activated as follows, NOAUDIT POLICY BY clause does not affect it.

```
AUDIT POLICY p1;
```

- It does not affect any.

```
NOAUDIT POLICY p1 BY u1;
```

- It should be deactivated as follows.

```
NOAUDIT POLICY p1;
```

If one or more users are separately activated, use NOAUDIT POLICY statement according to the AUDIT POLICY specifying method.

## When Activated by Using BY

If the audit policy is activated as follows,

```
AUDIT POLICY p1 WHENEVER NOT SUCCESSFUL;
AUDIT POLICY p1 BY u1;
AUDIT POLICY p1 BY u2;
```

the information about activation is as follows.

```
SELECT policy_name
       , enabled_opt
       , user_name
       , when_success
       , when_failure
FROM   audit_policy_enabled
WHERE  policy_name = 'P1';
```

POLICY_NAME	ENABLED_OPT	USER_NAME	WHEN_SUCCESS	WHEN_FAILURE
P1	BY	ALL USERS	NO	YES
P1	BY	U1	YES	YES
P1	BY	U2	YES	YES

The following is an example of performing NOAUDIT statement and the information about activation.

```
NOAUDIT POLICY p1;
SELECT policy_name
       , enabled_opt
       , user_name
       , when_success
       , when_failure
FROM   audit_policy_enabled
WHERE  policy_name = 'P1';
```

POLICY_NAME	ENABLED_OPT	USER_NAME	WHEN_SUCCESS	WHEN_FAILURE
P1	BY	U1	YES	YES
P1	BY	U2	YES	YES

The auditing for a failure for ALL USERS is deactivated, but the auditing for user u1, u2 is still activated.

If NOAUDIT POLICY statement is additionally used through BY option as follows, then audit policy p1 is completely deactivated.

```
NOAUDIT POLICY p1 BY u1, u2;
SELECT policy_name
       , enabled_opt
       , user_name
       , when_success
       , when_failure
FROM   audit_policy_enabled
WHERE  policy_name = 'P1';
no rows selected.
```

## When Activated by Using EXCEPT

If the audit policy is activated as follows,

```
AUDIT POLICY p1 EXCEPT u1, sys;
```

the information about activation is as follows.

```
SELECT policy_name
       , enabled_opt
       , user_name
       , when_success
       , when_failure
FROM   audit_policy_enabled
WHERE  policy_name = 'P1';
```

POLICY_NAME	ENABLED_OPT	USER_NAME	WHEN_SUCCESS	WHEN_FAILURE
P1	EXCEPT	U1	YES	YES
P1	EXCEPT	SYS	YES	YES

Unlike AUDIT POLICY statement, NOAUDIT POLICY does not have EXCEPT option, so execute the statement without an option as follows.

```
NOAUDIT POLICY p1;
SELECT policy_name
       , enabled_opt
       , user_name
```

```
, when_success  
, when_failure  
FROM audit_policy_enabled  
WHERE policy_name = 'P1';  
no rows selected.
```

In other words, if the audit policy is activated by using EXCEPT option, each user can not be activated again by using NOAUDIT POLICY statement.

## Examples

The following is an example of deactivating all users.

```
NOAUDIT POLICY table_pol;
```

The following is an example of deactivating a specific activated user by using BY.

```
NOAUDIT POLICY table_pol BY u1;
```

## Compatibility

The SQL standard does not have the audit policy.

## For More Information

Refer to the followings.

- Managing audit policy object
  - CREATE AUDIT POLICY
  - DROP AUDIT POLICY
  - ALTER AUDIT POLICY
- Activating/ deactivating audit policy
  - AUDIT POLICY
  - NOAUDIT POLICY
- Viewing audit trail: `AUDIT_TRAIL`

- Clearing audit trail: **ALTER DATABASE CLEAR AUDIT TRAIL**

## 20.9 OPEN cursor\_name

### Function

It opens a cursor.

### Syntax

```
<open statement> ::=  
    OPEN cursor_name [ <parameter using clause> ]  
    ;  
<parameter using clause> ::=  
    <using parameter arguments>  
<using parameter arguments> ::=  
    USING variable_name [, ...]
```

### Invocation and Access Rules

If `cursor_name` is a dynamic cursor which is declared by using `PREPARE statement_name` and `DECLARE cursor_name`, it can be used in an embedded SQL.

It is same with the privilege of `<cursor query>` included in `DECLARE cursor_name` which declared `cursor_name`.

### Syntax Rules and Parameters

#### cursor\_name

It should be a cursor declared with `DECLARE cursor_name` within the session.



## ⟨parameter using clause⟩

It can be used in an embedded SQL.

When ⟨parameter using clause⟩ is used, cursor\_name should be a dynamic cursor declared by using **PREPARE statement\_name** and **DECLARE cursor\_name**.

## ⟨using parameter arguments⟩

When ⟨using parameter arguments⟩ is used, the number of variable\_name should be equal to the number of the parameter included in a query which is referenced by **PREPARE statement\_name**.

The listed variable\_name corresponds to the dynamic parameter in an order of its description.

```
{
  ...
  EXEC SQL PREPARE stmt1 FROM 'SELECT c1, c2 FROM t1 WHERE c1 IN ( ?, ?, ? )';
  EXEC SQL DECLARE cur1 CURSOR FOR stmt1;
  EXEC SQL OPEN cur1 USING :sValue1, :sValue2, :sValue3;
  ...
  EXEC SQL WHENEVER NOT FOUND DO break;
  for(;;)
  {
    EXEC SQL FETCH cur1 INTO :sC1, :sC2;
  }
  EXEC SQL WHENEVER NOT FOUND CONTINUE;
  ...
  EXEC SQL CLOSE cur1;
  ...
}
```

## Description

The cursor is a distinguishable object in a session. The cursor being used in the current session has nothing to do with the cursor being used in another session.

To use OPEN cursor\_name statement, it should be a cursor declared with **DECLARE cursor\_name**, and it should be a closed cursor.

## Examples

The following is an example of declaring a cursor and using OPEN cursor statement in an interactive SQL (gsql).

```
gSQL> DECLARE cur1 CURSOR FOR SELECT id, data FROM t1;
Cursor declared.
gSQL> OPEN cur1;
Cursor is open.
gSQL> \var v_id    INTEGER
gSQL> \var v_data VARCHAR(128)
gSQL> FETCH cur1 INTO :v_id, :v_data;
V_ID V_DATA
-----
      1 data_1
1 row fetched.
gSQL> FETCH cur1 INTO :v_id, :v_data;
V_ID V_DATA
-----
      2 data_2
1 row fetched.
gSQL> FETCH cur1 INTO :v_id, :v_data;
V_ID V_DATA
-----
      3 data_3
1 row fetched.
gSQL> FETCH cur1 INTO :v_id, :v_data;
V_ID V_DATA
-----
      4 data_4
1 row fetched.
gSQL> FETCH cur1 INTO :v_id, :v_data;
V_ID V_DATA
-----
      5 data_5
1 row fetched.
gSQL> FETCH cur1 INTO :v_id, :v_data;
no rows fetched.
gSQL> CLOSE cur1;
Cursor closed.
```

# Compatibility

Table 20-3 SQL standard compatibility

Feature ID	Description	Compatibility
B031	Basic Dynamic SQL	O

## For More Information

Refer to the followings.

- DECLARE cursor\_name
- FETCH cursor\_name
- CLOSE cursor\_name
- PREPARE statement\_name

## 20.10 PREPARE statement\_name

### Function

It prepares a dynamic SQL statement for a repeated execution.

### Syntax

```
<prepare statement> ::=
    PREPARE statement_name FROM <SQL statement variable>
    ;
<SQL statement variable> ::=
    variable_name
    | 'sql statement'
    | "sql statement"
    | sql statement
```

### Invocation and Access Rules

It can be used in an embedded SQL.

An appropriate privilege according to the type of a dynamic SQL statement is required.

### Syntax Rules and Parameters

#### statement\_name

It is the name of the statement to be prepared.

The length of the statement name should be shorter than 128 bytes.

**EXECUTE statement\_name** and **DECLARE cursor\_name**, which are to be performed later, refers to the statement\_name.

If the same statement\_name exists, the previously prepared dynamic SQL is dropped.

```

{
  ...
  EXEC SQL PREPARE stmt1 FROM 'DELETE FROM t1';
  ...
  EXEC SQL PREPARE stmt1 FROM 'UPDATE t1 SET c1 = c1 + 10';
  ...
}

```

## ⟨SQL statement variable⟩

⟨SQL statement variable⟩ can be used as following four types.

- variable\_name: It is a variable in which an SQL statement is stored.
- 'sql statement': It is an SQL statement which is enclosed with single quote (').
- "sql statement": It is an SQL statement which is enclosed with double quotes (").
- sql statement: It is an SQL statement without quote.

The single quote (') is used twice as follows to represent string data within single-quoted string.

```

{
  ...
  PREPARE stmt_name FROM 'INSERT INTO t1 VALUES ( ''literal data'' )';
  ...
}

```

The dynamic SQL statement referenced by ⟨SQL statement variable⟩ can use a host variable (:var) or parameter marker (?).

However, if the unquoted SQL statement is used, the parameter marker (?) can not be used.

Depending on the characteristics of the referenced dynamic SQL statements, the variable can be either input or output dynamic parameter.

The dynamic parameter described in the dynamic SQL statement does not have a meaning for the variable name, and it is identified by the specified order regardless of its type.

- Example 1

```

{
  ...
  int sValue1;
  int sValue2;
  ...
  EXEC SQL PREPARE stmt1 FROM 'DELETE FROM t1 WHERE c1 BETWEEN ? AND ?';
}

```

```

EXEC SQL EXECUTE stmt1 USING :sValue1, :sValue2;
...
}

```

- All parameter markers are the input dynamic parameters.
- The order to identify
  - No. 1 - BETWEEN ?
    - Input dynamic parameter
    - It uses the value of :sValue1.
  - No. 2 - AND ?
    - Input dynamic parameter
    - It uses the value of :sValue2.
- Example 2

```

{
...
int sValue1;
int sValue2;
...
EXEC SQL PREPARE stmt1 FROM 'SELECT SUM(c2) INTO :v1 FROM t1 WHERE c1 > :v2';
EXEC SQL EXECUTE stmt1 USING :sValue1, :sValue2;
...
}

```

- The input dynamic parameter and the output dynamic parameter exist.
- The order to identify
  - No. 1 - :v1
    - Output dynamic parameter
    - It stores the value in :sValue1.
  - No. 2 - :v2
    - Input dynamic parameter
    - It uses the value of :sValue2.

## variable\_name

The type corresponding to variable\_name should be a character string.  
The dynamic SQL statement defined in variable\_name should be valid.

## sql statement

The dynamic SQL statement defined in the sql statement should be valid.

## Description

PREPARE statement\_name FROM sql\_string statement analyzes SQL statement to use EXECUTE or cursor statement. Statement\_name is an identifier which informs the precompiler the statement in an embedded SQL source code. A separate type or declaration is not required because statement\_name is not a host variable.

For more information, refer to **Embedded Dynamic SQL**.

## Example

The following is an example of using PREPARE statement\_name in an embedded SQL source code.

```
{
    ...
    sprintf( sUpdateSql, "UPDATE EMP SET sal = sal * :v1 WHERE JOB = 'SALES'");
    EXEC SQL PREPARE UPDATE_STMT FROM :sUpdateSql;
    if(sqlca.sqlcode != 0)
    {
        goto fail_exit;
    }
    sRatio = 1.1;
    EXEC SQL EXECUTE UPDATE_STMT USING :sRatio;
    if(sqlca.sqlcode != 0)
    {
        goto fail_exit;
    }
    ...
}
```

The full source code in which PREPARE statement\_name was used can be viewed in **Dynamic Embedded SQL Example Program**.

## Compatibility

Table 20-4 SQL standard compatibility

Feature ID	Description	Compatibility
B031	Basic Dynamic SQL	O
B034	Dynamic specification of cursor attributes	X

## For More Information

Refer to the followings.

- EXECUTE `statement_name`
- DECLARE `cursor_name`
- EXECUTE IMMEDIATE '`sql_string`'
- Embedded Dynamic SQL



## 20.11 PURGE

### Function

It permanently drops objects stored in the recycle bin.

### Syntax

```
<purge statement> ::=
    PURGE <purge action>
    ;
<purge action> ::=
    TABLE table_name
  | INDEX index_name
  | CONSTRAINT constraint_name
  | TABLESPACE tablespace_name [ USER user_name ]
  | RECYCLEBIN
  | USER_RECYCLEBIN
  | DBA_RECYCLEBIN
```

### Invocation and Access Rules

One of the following privilege is required for a user to perform <purge statement>.

- The owner of that table
- CONTROL TABLE ON TABLE for that table
- (DROP TABLE or CONTROL SCHEMA) ON SCHEMA for the schema to which the table belongs
- DROP ANY TABLE ON DATABASE

### Syntax Rules and Parameters

## **table\_name**

It is the name of the object stored or of the dropped table in the recycle bin.

It can define the schema to which the table belongs in the dropped table name, such as `schema_name.table_name`. If `schema_name` is omitted, the default schema name of the user performing the statement is used. In this case, indexes and constraints which are related to the table are also dropped.

## **index\_name**

It is the name of the object stored or of the dropped index in the recycle bin.

It can define the schema to which the index belongs such as `schema_name.index_name`.

If `schema_name` is omitted, the default schema name of the user performing the statement is used.

The key index which is created with a constraint should be dropped with the constraint.

## **constraint\_name**

It is the name of the object stored or of the dropped constraint in the recycle bin.

## **tablespace\_name**

It is the name of the tablespace.

When assigning `USER`, `DROP ANY TABLE ON DATABASE` privilege is required.

## **user\_name**

It is the name of the user.

## **recyclebin**

It is the alias of `user_recyclebin`.

## **user\_recyclebin**

It drops all recycle bins owned by a user.

## dba\_recyclebin

It drops all recycle bins in the database.

PURGE DBA\_RECYCLEBIN ON DATABASE privilege is required.

## Description

It permanently drops objects stored in the recycle bin by using the object name or the dropped table name stored in the recycle bin. If the name which is as same as that of the dropped table exists, then the oldest table object is dropped.

When specifying a tablespace in the recycle bin object owned by a user, then only the objects included in the tablespace are dropped. In this case, if a user is assigned, then only the objects included in the specified tablespace owned by the user are dropped.

PURGE TABLE, INDEX, CONSTRAINT statements can be rolled back if it is before when the transaction is committed. However, PURGE TABLESPACE, RECYCLEBIN, DBA\_RECYCLEBIN statements can not be rolled back, and the transaction which performed the statement is automatically committed.

## Example

The following is an example of dropping a table stored in the recycle bin.

```
gSQL> SELECT OBJECT_NAME, ORIGINAL_NAME, OBJECT_TYPE FROM USER_RECYCLEBIN;
OBJECT_NAME                ORIGINAL_NAME                OBJECT_TYPE
-----
BIN$135B9908166111EA9C5C835D3E4BBBF7 T1                            TABLE
BIN$135B993A166111EA9C5C835D3E4BBBF7 T1_PRIMARY_KEY                CONSTRAINT
BIN$135B991C166111EA9C5C835D3E4BBBF7 T1_PRIMARY_KEY_INDEX          INDEX
BIN$135B9926166111EA9C5C835D3E4BBBF7 T1_IDX1                        INDEX
4 rows selected.
gSQL> PURGE TABLE t1;
Table purged.
```

The following is an example of dropping an index stored in the recycle bin.

```
gSQL> SELECT OBJECT_NAME, ORIGINAL_NAME, OBJECT_TYPE FROM USER_RECYCLEBIN;
OBJECT_NAME                ORIGINAL_NAME                OBJECT_TYPE
-----
```

```

BIN$135B9908166111EA9C5C835D3E4BBBF7 T1          TABLE
BIN$135B993A166111EA9C5C835D3E4BBBF7 T1_PRIMARY_KEY  CONSTRAINT
BIN$135B991C166111EA9C5C835D3E4BBBF7 T1_PRIMARY_KEY_INDEX INDEX
BIN$135B9926166111EA9C5C835D3E4BBBF7 T1_IDX1          INDEX
4 rows selected.
gSQL> PURGE INDEX t1_idx1;
Index purged.

```

The following is an example of dropping constraints stored in the recycle bin.

```

gSQL> SELECT OBJECT_NAME, ORIGINAL_NAME, OBJECT_TYPE FROM USER_RECYCLEBIN;
OBJECT_NAME          ORIGINAL_NAME        OBJECT_TYPE
-----
BIN$135B9908166111EA9C5C835D3E4BBBF7 T1          TABLE
BIN$135B993A166111EA9C5C835D3E4BBBF7 T1_PRIMARY_KEY  CONSTRAINT
BIN$135B991C166111EA9C5C835D3E4BBBF7 T1_PRIMARY_KEY_INDEX INDEX
3 rows selected.
gSQL> PURGE CONSTRAINT t1_primary_key;
Constraints purged.

```

The following is an example of dropping objects included in the tablespace stored in the recycle bin.

```

gSQL> SELECT OBJECT_NAME, ORIGINAL_NAME, OBJECT_TYPE, TABLESPACE_NAME FROM USER_RECYCLEBIN;
OBJECT_NAME          ORIGINAL_NAME        OBJECT_TYPE        TABLESPACE_NAME
-----
BIN$02C76B24166311EA9C5C835D3E4BBBF7 T1          TABLE            MEM_DATA_TBS
1 row selected.
gSQL> PURGE TABLESPACE MEM_DATA_TBS;
Tablespace purged.

```

The following is an example of dropping all recycle bins owned by a user.

```

gSQL> SELECT OBJECT_NAME, ORIGINAL_NAME, OBJECT_TYPE FROM USER_RECYCLEBIN;
OBJECT_NAME          ORIGINAL_NAME        OBJECT_TYPE
-----
BIN$64F6BFFC166311EA9C5C835D3E4BBBF7 T1          TABLE
BIN$64F6C042166311EA9C5C835D3E4BBBF7 T1_PRIMARY_KEY  CONSTRAINT
BIN$64F6C010166311EA9C5C835D3E4BBBF7 T1_PRIMARY_KEY_INDEX INDEX
BIN$64F6C024166311EA9C5C835D3E4BBBF7 T1_IDX1          INDEX
4 rows selected.
gSQL> PURGE USER_RECYCLEBIN;
Recyclebin purged.

```

The following is an example of dropping all recycle bins in the system.

```
gSQL> SELECT OWNER, OBJECT_NAME, ORIGINAL_NAME, OBJECT_TYPE FROM USER_RECYCLEBIN;
OWNER OBJECT_NAME                                ORIGINAL_NAME                                OBJECT_TYPE
-----
TEST  BIN$F0FB26F0166311EAA7C5D51B86D72AB6 T1                                TABLE
TEST  BIN$F0FB272C166311EAA7C5D51B86D72AB6 T1_PRIMARY_KEY                    CONSTRAINT
TEST  BIN$F0FB2704166311EAA7C5D51B86D72AB6 T1_PRIMARY_KEY_INDEX              INDEX
TEST  BIN$F0FB2718166311EAA7C5D51B86D72AB6 T1_IDX1                            INDEX
4 rows selected.
gSQL> PURGE DBA_RECYCLEBIN;
DBA Recyclebin purged.
```

## Compatibility

The SQL standard does not define <purge statement>.

## For More Information

Refer to the followings.

- [Managing Recycle Bin of Table](#)
- [FLASHBACK TABLE](#)

## 20.12 RELEASE SAVEPOINT savepoint\_specifier

### Function

It releases a savepoint.

### Syntax

```
<release savepoint statement> ::=  
    RELEASE SAVEPOINT savepoint_name  
    ;
```

### Syntax Rules and Parameters

#### savepoint\_name

It is a name of the savepoint, and it should exist.

The length of the savepoint name should be shorter than 128 bytes.

### Description

If multiple savepoints are defined and `RELEASE SAVEPOINT savepoint_name` statement is performed, all savepoints defined since the `savepoint_name` are also released.

### Example

The following is an example of releasing a savepoint.

```
gSQL> RELEASE SAVEPOINT sp2;  
Savepoint dropped.
```

## Compatibility

Table 20-5 SQL standard compatibility

Feature ID	Description	Compatibility
T271	Savepoints	O

## For More Information

Refer to the followings.

- COMMIT
- ROLLBACK
- SAVEPOINT savepoint\_specifier

## 20.13 REVOKE privileges FROM

### Function

It revokes the granted privilege from a user.

### Syntax

```
<revoke privilege statement> ::=
    REVOKE [ <revoke option extention> ] <privilege>
        FROM <grantee> [, ...]
        [ <revoke behavior> ]
    ;
<revoke option extention> ::=
    GRANT OPTION FOR
<revoke behavior> ::=
    RESTRICT
    | CASCADE
    | CASCADE CONSTRAINTS
```

### Syntax Rules and Parameters

#### <privilege>

It is a privilege which is to be revoked from the revokee (the user whose privilege is to be revoked).

The revoker (the user who performs the statement) should satisfy one of the following conditions.

- If it is <privilege> which the revoker grants to the revokee.
  - Only the <privilege> which the revoker grants to the revokee is revoked.
- If the revoker owns ACCESS CONTROL ON DATABASE privilege.
  - The <privilege> which other grantors grant to the revokee is revoked.

When using ALL [PRIVILEGES], it succeeds even when the satisfying <privilege> does not exist.



For more information about the types of <privilege>, refer to <privilege> clause of **GRANT privileges TO** statement.

## <grantee>

It is a user whose privilege is to be revoked.

- user\_identifier
  - It revokes the privilege of that user.
- PUBLIC
  - They are authorization objects which mean all users.

## GRANT OPTION FOR

It revokes WITH GRANT OPTION included in the privilege.

It also revokes WITH GRANT OPTION of the dependent privilege.

The privilege is maintained.

## <revoke behavior>

- Dependent privilege: It is as same as the <privilege> which was granted to the revokee by using WITH GRANT OPTION and granted to another user by the revokee.
- RESTRICT
  - If the dependent privilege exists, it can not be revoked.
- CASCADE
  - The dependent privilege should also be revoked.
- CASCADE CONSTRAINTS
  - The dependent privilege should also be revoked.
- If it is omitted, the default value is CASCADE.

## Description

Data Definition Language (DDL) such as REVOKE privilege can be rolled back if it is before when the transaction is committed.

When performing the following DROP statement, all privilege information related to the object is revoked even without performing any separate REVOKE statement.

- DROP statement related to SQL schema object

- DROP TABLE
  - DROP VIEW
  - DROP SEQUENCE
  - ALTER TABLE name SET UNUSED COLUMN
  - DROP FUNCTION
  - DROP PROCEDURE
  - DROP PACKAGE
- DROP statement related to non-schema object
    - DROP SCHEMA
    - DROP TABLESPACE
    - DROP USER

## Examples

The following is an example of revoking multiple privileges for the table t1.

```
gSQL> REVOKE INSERT, UPDATE, DELETE, LOCK, ALTER, INDEX ON t1 FROM u1;  
Revoke succeeded.
```

The following is an example of revoking SELECT ON TABLE t1 privilege granted to the PUBLIC account, which means all users. However, only the privilege for PUBLIC account is revoked, and SELECT ON TABLE t1 privilege which was explicitly granted to a specific user is not revoked.

```
gSQL> REVOKE SELECT ON t1 FROM PUBLIC;  
Revoke succeeded.
```

The following is an example that SELECT ON TABLE t1 privilege granted to user u1 is remained, and only REVOKE GRANT OPTION which can grant the privilege to another user is revoked.

```
gSQL> REVOKE GRANT OPTION FOR SELECT ON t1 FROM u1;  
Revoke succeeded.
```

The following is an example that an error occurs when the privilege granted to the user u1 is revoked by using RESTRICT option and the user u1 grants it to another user. CASCADE option is used to revoke these dependent privileges as well.

```
gSQL> REVOKE SELECT ON t1 FROM u1 RESTRICT;  
ERR-2B000(16235): dependent privilege descriptors still exist  
gSQL> REVOKE SELECT ON t1 FROM u1 CASCADE;  
Revoke succeeded.
```

## Compatibility

The SQL standard does not define the following privileges.

- <database privilege>
- <tablespace privilege>
- <schema privilege>

<revoke behavior> of the SQL standard has the following differences.

- The default value of the SQL standard is RESTRICT.
- The SQL standard does not cover CASCADE CONSTRAINTS.

**Table 20-6** SQL standard compatibility

Feature ID	Description	Compatibility
T311	Basic roles	X
F034	Extended REVOKE statement	X
S081	Subtables	X

## For More Information

Refer to the followings.

- GRANT privileges TO
- <database privilege>
- <tablespace privilege>
- <schema privilege>
- <table privilege>
- Column privilege
- <sequence privilege>

## 20.14 ROLLBACK

### Function

It rolls back a transaction, or the operation after the savepoint.

### Syntax

```
<rollback statement> ::=  
    ROLLBACK [ WORK ] [ <rollback force clause> | <savepoint clause> ]  
    ;  
<rollback force clause> ::=  
    FORCE 'xid_string' [ COMMENT 'comment_string' ]  
<savepoint clause> ::=  
    TO SAVEPOINT savepoint_name
```

### Syntax Rules and Parameters

#### WORK

It is a reserved word which does not affect the operation.

#### <rollback force clause>

It is used to manually rollback the distributed transaction.

- FORCE 'xid\_string'
  - It rolls back the distributed transaction corresponding to 'xid\_string'.
  - 'xid\_string' consists of 'format\_id.transaction\_id.branch\_id'.
- COMMENT 'comment\_string'
  - It specifies the comment on a transaction when rolling back the distributed transaction.

## <savepoint clause>

It specifies the rollback scope of the current transaction.

- If it is omitted
  - It undoes all operations of the current transaction.
  - It ends the transaction.
  - It deletes all savepoints.
  - It releases all transaction locks.
- TO SAVEPOINT savepoint\_name
  - It undoes the operations of the current transaction since savepoint\_name.
  - It does not end the transaction.
  - It deletes all savepoints since savepoint\_name.
  - It releases all transaction locks acquired since savepoint\_name.

## Description

ROLLBACK statement undoes the following statements performed in the transaction.

- Data Manipulation Language (DML) statement
  - The statements to update data, such as INSERT, UPDATE and DELETE
- Data Definition Language (DDL) statement
  - The statements to alter the structure and definition of the object such as CREATE, DROP, ALTER, TRUNCATE, GRANT and REVOKE

Exceptionally, the following statements of DDL which deals with OS resources or alters the DATA TYPE can not be rolled back, but are automatically committed when executing the statement.

- CREATE TABLESPACE
- DROP TABLESPACE
- ALTER TABLESPACE
- ALTER TABLE .. ALTER COLUMN .. SET DATA TYPE: <alter column data type clause>

## Examples

The following is an example of rolling back the INSERT statement.

```

gSQL> INSERT INTO t1 VALUES ( 1, 'anonymous' );
1 row created.
gSQL> SELECT * FROM t1;
ID DATA
-- -----
1 anonymous
1 row selected.
gSQL> ROLLBACK;
Rollback complete.
gSQL> SELECT * FROM t1;
no rows selected.

```

The following is an example of ROLLBACK after performing the DROP TABLE statement.

```

gSQL> DROP TABLE t1;
Table dropped.
gSQL> SELECT * FROM t1;
ERR-42000(16040): table or view does not exist :
SELECT * FROM t1
          *
ERROR at line 1:
gSQL> ROLLBACK;
Rollback complete.
gSQL> SELECT * FROM t1;
ID DATA
-- -----
1 anonymous
1 row selected.

```

## Compatibility

**Table 20-7** SQL standard compatibility

Feature ID	Description	Compatibility
T271	Savepoints	O
T261	Chained transactions	X

## For More Information

Refer to the followings.

- COMMIT
- SAVEPOINT `savepoint_specifier`

## 20.15 SAVEPOINT savepoint\_specifier

### Function

It defines a savepoint.

### Syntax

```
<savepoint statement> ::=  
    SAVEPOINT savepoint_name  
    ;
```

### Syntax Rules and Parameters

#### savepoint\_name

It is a name of the savepoint.

If the savepoint name is as same as the existing savepoint name, then the existing savepoint is deleted.

The length of the savepoint name should be shorter than 128 bytes.

### Description

The defined savepoint is used by ROLLBACK TO SAVEPOINT statement (refer to **ROLLBACK.**), and DML or DDL statement which has been performed up to the savepoint is rolled back. Then the locks acquired by using that statement are released, too.

The defined savepoint is automatically deleted when the transaction is committed or rolled back, or it can be explicitly deleted by using **RELEASE SAVEPOINT savepoint\_specifier**.



## Example

The following is an example of defining the savepoint and using ROLLBACK TO SAVEPOINT statement.

```
gSQL> SAVEPOINT sp1;
Savepoint created.
gSQL> INSERT INTO t1 VALUES ( 1, 'anonymous' );
1 row created.
gSQL> SAVEPOINT sp2;
Savepoint created.
gSQL> INSERT INTO t1 VALUES ( 2, 'someone' );
1 row created.
gSQL> SAVEPOINT sp3;
Savepoint created.
gSQL> INSERT INTO t1 VALUES ( 3, 'anyone' );
1 row created.
gSQL> SELECT * FROM t1;
ID DATA
-- -----
1 anonymous
2 someone
3 anyone
3 rows selected.
gSQL> ROLLBACK TO SAVEPOINT sp3;
Rollback complete.
gSQL> SELECT * FROM t1;
ID DATA
-- -----
1 anonymous
2 someone
2 rows selected.
gSQL> ROLLBACK TO SAVEPOINT sp2;
Rollback complete.
gSQL> SELECT * FROM t1;
ID DATA
-- -----
1 anonymous
1 row selected.
gSQL> ROLLBACK TO SAVEPOINT sp1;
Rollback complete.
```

```
gSQL> SELECT * FROM t1;  
no rows selected.
```

## Compatibility

Table 20-8 SQL standard compatibility

Feature ID	Description	Compatibility
T271	Savepoints	O

## For More Information

Refer to the followings.

- COMMIT
- ROLLBACK
- RELEASE SAVEPOINT `savepoint_specifier`

## 20.16 SELECT

### query expression

#### Function

It retrieves desired rows from one or more tables or views.

#### Syntax

```

<query expression> ::=
    [ <with clause> ] <query expression body> [ <order by clause> ] [ <offset limit clause> ]
<query expression body> ::=
    <query term>
    | <set operator>
<query term> ::=
    <query specification>
    | <left paren> <query expression body> [ <order by clause> ] [ <offset limit clause> ]
    <right paren>

```

#### Invocation and Access Rules

One of the following privileges for all tables used in the statement is required for a user to perform <query expression>.

- SELECT(columns) ON TABLE for all used columns of table in the statement
- (SELECT or CONTROL TABLE) ON TABLE for the table
- (SELECT TABLE or CONTROL SCHEMA) ON SCHEMA for the schema to which the table belongs
- SELECT ANY TABLE ON DATABASE

#### Syntax Rules and Parameters

##### <with clause>

<with clause> defines the temporary result set, and it refers to that result set.

For more information, refer to **with clause**.

## <set operator>

It performs a set operation among the subqueries.

For more information, refer to **set operator**.

## <query specification>

It specifies a single subquery.

For more information, refer to **<query specification>**.

## <order by clause>

It specifies sorting information of a query result.

For more information, refer to **order by clause**.

## <offset limit clause>

It specifies the number of rows to skip and the number of rows to fetch from the query result set.

For more information, refer to **offset limit clause**.

## Description

It specifies a query with SELECT statement.

<with clause>, <order by clause>, <offset limit clause> can be omitted.

Two or more subqueries can be specified by using <set operator>.

## Examples

The following is an example of SELECT statement.

```
gSQL> SELECT s_name, s_nation FROM supplier;
S_NAME          S_NATION
-----
Supplier#1      FRANCE
Supplier#2      KOREA
Supplier#3      GERMANY
Supplier#4      UNITED STATES
Supplier#5      CANADA
5 rows selected.
```

The following is an example of the SELECT statement which uses <order by clause>.

```
gSQL> SELECT s_name, s_nation FROM supplier ORDER BY s_name DESC;
```

S_NAME	S_NATION
Supplier#5	CANADA
Supplier#4	UNITED STATES
Supplier#3	GERMANY
Supplier#2	KOREA
Supplier#1	FRANCE

5 rows selected.

The following is an example of the SELECT statement which uses <offset limit clause>.

```
gSQL> SELECT s_name, s_nation FROM supplier OFFSET 1;
```

S_NAME	S_NATION
Supplier#2	KOREA
Supplier#3	GERMANY
Supplier#4	UNITED STATES
Supplier#5	CANADA

4 rows selected.

```
gSQL> SELECT s_name, s_nation FROM supplier LIMIT 1;
```

S_NAME	S_NATION
Supplier#1	FRANCE

1 row selected.

The following is an example of the SELECT statement which uses <order by clause> and <offset limit clause>.

```
gSQL> SELECT s_name, s_nation FROM supplier ORDER BY s_name DESC OFFSET 3 LIMIT 1;
```

S_NAME	S_NATION
Supplier#2	KOREA

1 row selected.

The following is an example of SELECT statement which uses <with clause>.

\* Non Recursive CTE

```
gSQL> WITH revenue ( supplier_no, total_revenue ) AS
```

```
(
```

```
    SELECT
```

```
        l_suppkey,
```

```

        SUM(l_extendedprice * (1 - l_discount))
    FROM lineitem
    WHERE l_shipdate >= DATE '1996-01-01'
        AND l_shipdate < DATE '1996-01-01' + INTERVAL '3' MONTH
    GROUP BY
        l_suppkey
)
select
    s_suppkey,
    s_name,
    s_address,
    s_phone,
    ROUND( total_revenue, 2 ) as total_revenue
from
    supplier,
    revenue
where
    s_suppkey = supplier_no
    and total_revenue = (
        select
            max(total_revenue)
        from
            revenue
    )

order by
    s_suppkey;
S_SUPPKEY S_NAME                S_ADDRESS                S_PHONE                TOTAL_REVENUE
-----
      8449 Supplier#000008449    Wp34zim9qYFbVctdW 20-469-856-8873    1772627.21

```

1 row selected.

\* Recursive CTE

```
gSQL> WITH GenerateRecord ( c1, c2 ) AS
```

```

(
    SELECT 1, 11
    FROM dual
    UNION ALL
    SELECT c1 + 1, c2 + 1
    FROM GenerateRecord
    WHERE c1 < 10
)

```

```
SELECT c1, c2 FROM GenerateRecord;
```

```

C1 C2
-- --
 1 11
 2 12
 3 13
 4 14
 5 15
 6 16
 7 17
 8 18
 9 19
10 20
10 rows selected.

```

## Compatibility

Table 20-9 SQL standard compatibility

Feature ID	Description	Compatibility
T121	WITH(excluding RECURSIVE) in query expression	O
T122	WITH(excluding RECURSIVE) in subquery	O
T131	Recursive query	O
T132	Recursive query in subquery	O
F661	Simple tables	O
F302	INTERSECT table operator	O
F301	CORRESPONDING in query expressions	X
T551	Optional key words for default syntax	O
F304	EXCEPT ALL table operator	O
F850	Top-level <order by clause> in <query expression>	O
F851	<order by clause> in subqueries	O
F855	Nested <order by clause> in <query expression>	O
F856	Nested <fetch first clause> in <query expression>	O
F857	Top-level <fetch first clause> in <query expression>	O
F858	<fetch first clause> in subqueries	O
F860	dynamic <fetch first row count> in <fetch first clause>	X
F861	Top-level <result offset clause> in <query expression>	O
F862	<result offset clause> in subqueries	O
F863	Nested <result offset clause> in <query expression>	O
F865	dynamic <offset row count> in <result offset clause>	X
F866	FETCH FIRST clause: PERCENT option	X
F867	FETCH FIRST clause: WITH TIES option	X

## with clause

### Function

<with clause> defines the temporary result set, and it refers to that result set.

The result set a temporary result set with a given name, and it is defined and referred in SELECT statement. It is called as Common Table Expression (CTE).

### Syntax

```

<with clause> ::=
    WITH <with list>
<with list> ::=
    <with list element> [ { <comma> <with list element> }... ]
<with list element> ::=
    <query name> [ <left paren> <with column list> <right paren> ]
    AS <table subquery> [ <search or cycle clause> ]
<with column list> ::=
    <column name list>

<search or cycle clause> ::=
    <search clause>
    | <cycle clause>
    | <search clause> <cycle clause>
<search clause> ::=
    SEARCH <recursive search order> SET <sequence column>
<recursive search order> ::=
    DEPTH FIRST BY <ordering column list>
    | BREADTH FIRST BY <ordering column list>
<ordering column list> ::=
    <ordering column> [ { <comma> <ordering column> }... ]
<ordering column> ::=
    <column name> [ ASC | DESC ] [ NULLS FIRST | NULLS LAST ]
<sequence column> ::=
    <column name>
<cycle clause> ::=
    CYCLE <cycle column list> SET <cycle mark column> TO <cycle mark value>
    DEFAULT <non-cycle mark value>
<cycle column list> ::=
    <cycle column> [ { <comma> <cycle column> }... ]
  
```



```
<cycle column> ::=  
    <column name>  
  
<cycle mark column> ::=  
    <column name>  
  
<cycle mark value> ::=  
    <value expression>  
<non-cycle mark value> ::=  
    <value expression>
```

## Invocation and Access Rules

It is supported in `<query expression>` statement, and the user should satisfy the access privilege of `<query expression>` to perform it.

For more information, refer to [query expression](#).

## Syntax Rules and Parameters

### `<with list>`

It can define multiple `<with list element>`.

### `<with list element>`

It defines the temporary result set of specified `<query name>`.

`<with list element>` is called as Common Table Expression (CTE).

CTE is divided into a recursive CTE and a non-recursive CTE.

For more information, refer to [Description](#).

- Referring to CTE
  - Referring to CTE is restricted according to the described sequence.
  - CTE described before the current CTE can be referenced.
  - CTE described after the current CTE can not be referenced.
- Non-recursive CTE
  - CTE described before the current CTE can be referenced in `<with list element>`.
- Recursive CTE
  - Either self CTE, or CTE described before the current CTE can be referenced in `<with list element>`.
  - Self-reference CTE is allowed only once within CTE.

```
--# success : non recursive CTE
WITH CTE_1( c1 ) AS
(
    SELECT i1
        FROM t1
),
CTE_2( c2 ) AS
(
    SELECT c1
        FROM CTE_1      ❶ Referring to the leading CTE
)
SELECT c2 FROM CTE_2;
--# error : non recursive CTE
WITH CTE_1( c1 ) AS
(
    SELECT c2
        FROM CTE_2      ❷ Referring to the trailing CTE
),
CTE_2( c2 ) AS
(
    SELECT i1
        FROM t1
)
SELECT c1 FROM CTE_1;

--# success : recursive CTE
WITH CTE_1( c1 ) AS
(
    SELECT i1
        FROM t1
),
CTE_2( c2 ) AS
(
    SELECT c1
        FROM CTE_1      ❶ Referring to the leading CTE
),
CTE_3( c3 ) AS
(
    SELECT 1
        FROM CTE_1
    UNION ALL
```

```

        SELECT 1
        FROM CTE_2, CTE_3 ❷ Referring to the leading CTE or self CTE
    )
SELECT c3 FROM CTE_3;
--# error : recursive CTE
WITH CTE_RECURSIVE( c1 ) AS
(
    SELECT i1
    FROM t1
    WHERE i1 IS NULL
    UNION ALL
    SELECT 1
    FROM CTE_RECURSIVE A, CTE_RECURSIVE B ❸ Self-reference CTE is allowed only once
    WHERE 1 = 0
)
SELECT c1 FROM CTE_RECURSIVE;

```

### <query name>

<query name> should not be duplicated within WITH clause.

### <with column list>

Recursive CTE can not omit <with column list>.

### <search clause>

- Non-recursive CTE
  - It can not describe <search clause>.
- Recursive CTE
  - It describes the sort order of CTE result records.
- <recursive search order>
  - DEPTH FIRST BY
    - Child rows are returned before sibling rows are returned.
  - BREADTH FIRST BY
    - Sibling rows are returned before child rows are returned.
- <ordering column list>
  - It specifies the ordering of column list.
  - Sort order
    - ASC

- DESC
    - If not specified, the default value is ASC.
  - Null ordering
    - NULLS FIRST
    - NULLS LAST
    - If not specified, the default value is NULLS LAST.
  - It should describe <with column list> declared in <with list element>.
  - It does not support LONG type (LONG VARCHAR, LONG VARBINARY).
- <sequence column>
    - It stores the sequence of CTE result records.
    - <column name> should not be a duplicate of following items.
      - The column name declared in <with column list> of <with list element>
      - The column name declared in <cycle column list> of <cycle clause>

## <cycle clause>

- Non-recursive CTE
  - It can not describe <cycle clause>.
- Recursive CTE
  - If <cycle clause> is omitted, it returns an error when cycle occurs.

It stores <cycle mark value> or <non-cycle mark value> in <cycle mark column> according to whether cycle occurs.

- <cycle column list>
  - It should describe <with column list> declared in <with list element>.
- <cycle mark column>
  - <column name> should not be a duplicate of following items.
    - The column name declared in <with column list> of <with list element>
    - The column name declared in <sequence column> of <search clause>
- <cycle mark value> or <non-cycle mark value>
  - It can describe 1 byte character only.

## Description

<with clause> defines a temporary result set, and it can refer to that result set.

It is defined and referenced within SELECT statement, and it is a temporary result set with a given name.

It is called as Common Table Expression (CTE).

CTE is classified into recursive CTE and non-recursive CTE.

- Recursive CTE: It refers to CTE which is currently defined within CTE (self-reference CTE).

```
WITH RECURSIVE_CTE ( c1 ) AS
(
    SELECT 1
      FROM dual
    UNION ALL
    SELECT c1 + 1
      FROM RECURSIVE_CTE
     WHERE c1 < 10
)
SELECT c1 FROM RECURSIVE_CTE;
```

- Non-recursive CTE: It is CTE other than recursive CTE.

```
WITH NON_RECURSIVE_CTE ( c1 ) AS
(
    SELECT i1
      FROM t1
    UNION ALL
    SELECT i1
      FROM t2
)
SELECT c1 FROM NON_RECURSIVE_CTE;
```

<with clause> can be described in SELECT, INSERT, UPDATE, DELETE, CREATE TABLE AS SELECT, CREATE VIEW statement.

## <with list element>

It defines the temporary result set of the described <query name>.

<with list element> is called as Common Table Expression (CTE).

CTE is classified into recursive CTE and non-recursive CTE.

- Recursive CTE
  - It refers to CTE which is currently defined within CTE (self-reference CTE).
  - The query block including the self-reference CTE is called as a recursive member query.
  - The query block other than a recursive member query is called as an anchor member query.
  - The recursive member query and the anchor member query should be composed of UNION ALL.
  - Only one recursive member query can be described.
- Non-recursive CTE: It is CTE other than recursive CTE.

```

WITH CTE_RECURSIVE( c1, c2 ) AS
(
    SELECT i1, i2                                ❶ Anchor member query
      FROM t1
     WHERE i2 IS NULL
    UNION ALL
    SELECT i1, i2                                ❷ Recursive member query
      FROM CTE_RECURSIVE, t1                    ❸ Self reference
     WHERE CTE_RECURSIVE.c1 = t1.i2
)
SELECT c1, c2 FROM CTE_RECURSIVE;

```

- The recursive member query can not include the following items.
  - GROUP BY or DISTINCT clause
    - (X) SELECT i1, i2 FROM CTE\_RECURSIVE, t1 WHERE CTE\_RECURSIVE.c1 = t1.i2 GROUP BY i1, i2
    - (X) SELECT DISTINCT i1, i2 FROM CTE\_RECURSIVE, t1 WHERE CTE\_RECURSIVE.c1 = t1.i2
  - Referring to CTE in the inner part of LEFT, RIGHT, OUTER JOIN
    - (X) SELECT i1, i2 FROM t1 LEFT OUTER JOIN CTE\_RECURSIVE ON t1.i2 = CTE\_RECURSIVE.c1
  - Aggregation function
    - (X) SELECT MAX(i1), MAX(i2) FROM CTE\_RECURSIVE, t1 WHERE CTE\_RECURSIVE.c1 = t1.i2
  - Subquery including self-reference CTE
    - (X) SELECT i1, i2 FROM ( SELECT \* FROM CTE\_RECURSIVE ) cte, t1 WHERE cte.c1 = t1.i2

## <search clause>

It describes the sort order of CTE result records.

Sibling rows are sorted with <ordering column list>, it specifies the returning order of sibling rows and child rows for the sorted records.

The sequence of result records are stored in <sequence column>.

- DEPTH FIRST BY
  - Child rows are returned before sibling rows are returned.
- BREADTH FIRST BY
  - Sibling rows are returned before child rows are returned.

```

gSQL>
SELECT * FROM t1;
I1 I2
--- ---
A   ---
AA  A

```

```

AB A
AC A
AAX AA
ABX AB
ACX AC
7 rows selected.
* SEARCH BREADTH FIRST BY
gSQL>
WITH w1( w_i1, w_i2 ) AS
(
    SELECT i1, i2
       FROM t1
      WHERE i1 = 'A'
    UNION ALL
    SELECT i1, i2
       FROM w1, t1
      WHERE w_i1 = i2
) SEARCH BREADTH FIRST BY w_i1, w_i2 SET w_seq
SELECT w_i1, w_i2, w_seq
   FROM w1;
W_I1 W_I2 W_SEQ
---- ----
A    ---    1
AA   A     2
AB   A     3
AC   A     4
AAX  AA    5
ABX  AB    6
ACX  AC    7
7 rows selected.
* SEARCH DEPTH FIRST BY
gSQL>
WITH w1( w_i1, w_i2 ) AS
(
    SELECT i1, i2
       FROM t1
      WHERE i1 = 'A'
    UNION ALL
    SELECT i1, i2
       FROM w1, t1
      WHERE w_i1 = i2

```

```

    ) SEARCH DEPTH FIRST BY w_i1, w_i2 SET w_seq
SELECT w_i1, w_i2, w_seq
FROM w1;
W_I1 W_I2 W_SEQ
---- -
A    ---    1
AA   A      2
AAX  AA     3
AB   A      4
ABX  AB     5
AC   A      6
ACX  AC     7
7 rows selected.

```

## <cycle clause>

If <cycle clause> statement is not described, then an error occurs when cycle occurs.

<cycle column list> is used to check cycle.

It stores <cycle mark value> or <non-cycle mark value> in <cycle mark column> according to whether cycle occurs.

Only 1 byte character can be described in <cycle mark value> or <non-cycle mark value>.

<cycle mark value> is stored in <cycle mark column> of the record where cycle occurred. In this case, it stops further recursion, and returns only until the record where cycle occurred

The recursion continuously proceeds for sibling rows where cycle does not occurred.

```

gSQL>
SELECT * FROM t1;
I1  I2
--- ---
A   ---
AA  A
AB  A
AC  A
AA  AA
AAX AA
ABX AB
ACX AC
8 rows selected.

```

- When cycle occurred and cycle clause is not described



```

gSQL>
WITH w1( w_i1, w_i2 ) AS
  (
    SELECT i1, i2
      FROM t1
     WHERE i1 = 'A'
    UNION ALL
    SELECT i1, i2
      FROM w1, t1
     WHERE w_i1 = i2
  )
SELECT w_i1, w_i2
  FROM w1;
ERR-42000(16511): cycle detected while executing recursive WITH query

```

- When cycle occurred and cycle clause is described

```

gSQL>
WITH w1( w_i1, w_i2 ) AS
  (
    SELECT i1, i2
      FROM t1
     WHERE i1 = 'A'
    UNION ALL
    SELECT i1, i2
      FROM w1, t1
     WHERE w_i1 = i2
  ) CYCLE w_i1, w_i2 SET c_cycle TO 'T' DEFAULT 'F'
SELECT w_i1, w_i2, c_cycle
  FROM w1;
W_I1 W_I2 C_CYCLE
-----
A    ---  F
AC   A    F
AB   A    F
AA   A    F
ACX  AC   F
ABX  AB   F
AAX  AA   F
AA   AA   F
AAX  AA   F

```

```
AA  AA  T
10 rows selected.
```

## Examples

The following is an example of SELECT statement which uses WITH clause.

- Non-recursive CTE

```
gSQL>
WITH revenue ( supplier_no, total_revenue ) AS
    (
        SELECT
            l_suppkey,
            SUM(l_extendedprice * (1 - l_discount))
        FROM lineitem
        WHERE l_shipdate >= DATE '1996-01-01'
            AND l_shipdate < DATE '1996-01-01' + INTERVAL '3' MONTH
        GROUP BY
            l_suppkey
    )
select
    s_suppkey,
    s_name,
    s_address,
    s_phone,
    ROUND( total_revenue, 2 ) as total_revenue
from
    supplier,
    revenue
where
    s_suppkey = supplier_no
    and total_revenue = (
        select
            max(total_revenue)
        from
            revenue
    )
order by
    s_suppkey;
S_SUPPKEY S_NAME          S_ADDRESS          S_PHONE          TOTAL_REVENUE
```

```
-----
      8449 Supplier#000008449      Wp34zim9qYFbVctdW 20-469-856-8873      1772627.21
1 row selected.
```

- Recursive CTE

```
gSQL>
WITH GenerateRecord ( c1, c2 ) AS
  (
    SELECT 1, 11
      FROM dual
    UNION ALL
    SELECT c1 + 1, c2 + 1
      FROM GenerateRecord
    WHERE c1 < 10
  )
SELECT c1, c2 FROM GenerateRecord;
C1 C2
-- --
 1 11
 2 12
 3 13
 4 14
 5 15
 6 16
 7 17
 8 18
 9 19
10 20
10 rows selected.
```

The following is the result of retrieving record in emp table which will be used in the example of WITH clause.

```
gSQL>
SELECT * FROM emp;
NAME      MGR
-----
Kelly     null
Bill      Kelly
Jackson   Kelly
Joe       Kelly
```

```

Scott  Bill
Larry  Bill
Paul   Jackson
Bill   Bill
8 rows selected.

```

The following is an example of using SEARCH BREADTH FIRST BY.

- Cycle occurred

```

gSQL>
WITH w_emp( w_name, w_mgr ) AS
  (
    SELECT name, mgr
      FROM emp
     WHERE mgr IS NULL
    UNION ALL
    SELECT name, mgr
      FROM emp, w_emp
     WHERE mgr = w_emp.w_name
  ) SEARCH BREADTH FIRST BY w_name SET w_seq
SELECT w_name, w_mgr, w_seq
  FROM w_emp;
ERR-42000(16511): cycle detected while executing recursive WITH query

```

- Retrieve the data by describing cycle clause in the statement above after cycle occurred.

```

gSQL>
WITH w_emp( w_name, w_mgr ) AS
  (
    SELECT name, mgr
      FROM emp
     WHERE mgr IS NULL
    UNION ALL
    SELECT name, mgr
      FROM emp, w_emp
     WHERE mgr = w_emp.w_name
  ) SEARCH BREADTH FIRST BY w_name SET w_seq
  CYCLE w_name SET w_cycle TO 'T' DEFAULT 'F'
SELECT w_name, w_mgr, w_seq, w_cycle
  FROM w_emp;
W_NAME  W_MGR  W_SEQ  W_CYCLE

```

```

-----
Kelly  null      1 F
Bill   Kelly     2 F
Jackson Kelly    3 F
Joe    Kelly     4 F
Bill   Bill      5 T
Larry  Bill      6 F
Paul   Jackson   7 F
Scott  Bill      8 F
8 rows selected.

```

The following is an example of using SEARCH DEPTH FIRST BY.

```

gSQL>
WITH w_emp( w_name, w_mgr ) AS
  (
    SELECT name, mgr
      FROM emp
     WHERE mgr IS NULL
    UNION ALL
    SELECT name, mgr
      FROM emp, w_emp
     WHERE mgr = w_emp.w_name
  ) SEARCH DEPTH FIRST BY w_name SET w_seq
  CYCLE w_name SET w_cycle TO 'T' DEFAULT 'F'
SELECT w_name, w_mgr, w_seq, w_cycle
  FROM w_emp;
W_NAME  W_MGR  W_SEQ W_CYCLE
-----
Kelly   null    1 F
Bill    Kelly  2 F
Bill    Bill   3 T
Larry   Bill   4 F
Scott   Bill   5 F
Jackson Kelly  6 F
Paul    Jackson 7 F
Joe     Kelly  8 F
8 rows selected.

```

The following is an example of using *with clause* in CREATE TABLE AS SELECT statement.

```

gSQL>
CREATE TABLE new_emp AS
WITH w_emp( w_name, w_mgr ) AS
  (
    SELECT name, mgr
      FROM emp
     WHERE mgr IS NULL
    UNION ALL
    SELECT name, mgr
      FROM emp, w_emp
     WHERE mgr = w_emp.w_name
  ) SEARCH BREADTH FIRST BY w_name SET w_seq
  CYCLE w_name SET w_cycle TO 'T' DEFAULT 'F'
SELECT w_name, w_mgr, w_seq, w_cycle
  FROM w_emp;
Table created.

```

The following is an example of using *with clause* in INSERT statement.

```

gSQL>
INSERT INTO new_emp
WITH w_emp( w_name, w_mgr ) AS
  (
    SELECT name, mgr
      FROM emp
     WHERE mgr = 'Bill'
    UNION ALL
    SELECT name, mgr
      FROM emp, w_emp
     WHERE mgr = w_emp.w_name
  ) SEARCH BREADTH FIRST BY w_name SET w_seq
  CYCLE w_name SET w_cycle TO 'T' DEFAULT 'F'
SELECT w_name, w_mgr, w_seq, w_cycle
  FROM w_emp;
6 rows created.

```

The following is an example of using *with clause* in UPDATE statement.

```

gSQL>
UPDATE new_emp SET w_name = NULL
  WHERE ( w_name, w_mgr )

```

```

IN ( WITH w_emp( w_name, w_mgr ) AS
    (
        SELECT name, mgr
          FROM emp
         WHERE mgr = 'Bill'
        UNION ALL
        SELECT name, mgr
          FROM emp, w_emp
         WHERE mgr = w_emp.w_name
    ) SEARCH BREADTH FIRST BY w_name SET w_seq
    CYCLE w_name SET w_cycle TO 'T' DEFAULT 'F'
  SELECT w_name, w_mgr
    FROM w_emp );

```

9 rows updated.

The following is an example of using *with clause* in DELETE statement.

```

gSQL>
DELETE FROM new_emp
WHERE ( w_mgr )
    IN ( WITH w_emp( w_name, w_mgr ) AS
        (
            SELECT name, mgr
              FROM emp
             WHERE mgr = 'Bill'
            UNION ALL
            SELECT name, mgr
              FROM emp, w_emp
             WHERE mgr = w_emp.w_name
        ) SEARCH BREADTH FIRST BY w_name SET w_seq
        CYCLE w_name SET w_cycle TO 'T' DEFAULT 'F'
      SELECT w_mgr
        FROM w_emp );

```

9 rows deleted.

The following is an example of using *with clause* in CREATE VIEW statement.

```

gSQL>
CREATE VIEW v_emp AS
WITH w_emp( w_name, w_mgr ) AS
    (
        SELECT name, mgr

```

```
        FROM emp
        WHERE mgr IS NULL
    UNION ALL
    SELECT name, mgr
        FROM emp, w_emp
        WHERE mgr = w_emp.w_name
) SEARCH BREADTH FIRST BY w_name SET w_seq
CYCLE w_name SET w_cycle TO 'T' DEFAULT 'F'
SELECT w_name, w_mgr, w_seq, w_cycle
    FROM w_emp;
View created.
```



# query specification

## Function

It specifies the table which is derived from the result of <table expression>.

## Syntax

```
<query specification> ::=
    SELECT [ <hint clause> ] [ <set quantifier> ] <select list> <table expression>
<set quantifier> ::=
    ALL
    | DISTINCT
<table expression> ::=
    <from clause> [ <where clause> ] [ <hierarchical query clause> ] [ <group by clause> ] [
<having clause> ]
```

## Invocation and Access Rules

The user should satisfy one of the following conditions to perform <query specification>.

- The owner of that table
- SELECT privilege for the table
- The user owns one of SELECT TABLE, CONTROL TABLE, CONTROL privileges for the schema to which the table belongs
- The user owns the SELECT TABLE privilege for the database

## Syntax Rules and Parameters

### <hint clause>

It specifies the hint for query execution.  
For more information, refer to [SQL Hint](#).

### <set quantifier>

It specifies whether to remove a duplicate of the query result.  
If it is omitted, it operates in the same way as ALL.

### <select list>

It specifies the column to be retrieved among query results.

For more information, refer to **select list**.

### <from clause>

It specifies the tables to be retrieved.

For more information, refer to **from clause**.

### <where clause>

It specifies conditions for retrieving.

For more information, refer to **where clause**.

### <hierarchical query clause>

It specifies to retrieve the hierarchical model data in a hierarchy.

For more information, refer to **hierarchical query clause**.

### <group by clause>

It specifies grouping of the query result.

For more information, refer to **group by clause**.

### <having clause>

It specifies conditions for the grouping result.

For more information, refer to **having clause**.

## Description

### <hint clause>

<hint clause> is a comment which the user uses to directly command an optimizer how to execute SQL statement.

The optimizer of GOLDILOCKS preferentially applies <hint clause> specified by a user.

If it is not applicable, the optimizer selects the best execution plan through the cost calculation.

Even when a syntactic error occurs in <hint clause>, GOLDILOCKS is set to ignore and perform it by default. Set **HINT\_ERROR** property to *on*, then execute the query to check if a syntactic error exist in <hint clause>.

## ⟨set quantifier⟩

⟨set quantifier⟩ sets whether to remove duplicates from the result set consisting of the ⟨select list⟩ expressions.

- ALL: It does not remove the duplicates from the result set.
- DISTINCT: It removes the duplicates from the result set.
- If it is omitted, it is operated by default which is as same as ALL.

## ⟨select list⟩

It specifies columns to be retrieved from the query result.

They are listed by separating by a comma (,).

An asterisk (\*) is used to specify all columns in ⟨from clause⟩.

## ⟨from clause⟩

⟨from clause⟩ specifies the tables or views to be retrieved.

## ⟨where clause⟩

⟨where clause⟩ specifies the conditions to get only the desired results from the result obtained from ⟨from clause⟩.

## ⟨hierarchical query clause⟩

It specifies to retrieve the hierarchical model data in a hierarchy.

It returns table records in a hierarchy of depth-first sequence by using the launch condition and sub-connectivity condition.

## ⟨group by clause⟩

⟨group by clause⟩ specifies the method of grouping the result set to which ⟨where clause⟩ was applied.

When ⟨group by clause⟩ is specified, the following expressions can be used in ⟨select list⟩.

- Constant number
- Expression specified in *group by*
- Operation expression specified in *group by*
- Aggregation function for an expression belonging to a group

## <having clause>

<having clause> specifies the retrieving condition for the grouped result set. It is generally used together with <group by clause>.

## Examples

The following is an example of SELECT statement which uses <hint clause>.

```
gSQL> SELECT /*+ INDEX_DESC(supplier, supplier_pk_index) */ s_name, s_nation FROM supplier;
S_NAME                S_NATION
-----
Supplier#5            CANADA
Supplier#4            UNITED STATES
Supplier#3            GERMANY
Supplier#2            KOREA
Supplier#1            FRANCE
5 rows selected.
```

The following is an example of SELECT statement which uses <set quantifier>.

```
gSQL> SELECT ALL p_type FROM part;
P_TYPE
-----
COPPER
NICKEL
STEEL
NICKEL
STEEL
5 rows selected.
gSQL> SELECT DISTINCT p_type FROM part;
P_TYPE
-----
COPPER
STEEL
NICKEL
3 rows selected.
```

The following is an example of SELECT statement which uses <where clause>.

```
gSQL> SELECT p_name, p_brand, p_type, p_size FROM part where p_size < 10;
P_NAME P_BRAND   P_TYPE P_SIZE
-----
Part#1 Brand#1  COPPER    7
Part#2 Brand#1  NICKEL    1
2 rows selected.
```

The following is an example of retrieving the hierarchy data of SELECT statement by using <hierarchical query clause>.

```
gSQL> SELECT *
      FROM emp
      START WITH mgr IS NULL
      CONNECT BY NOCYCLE mgr = PRIOR name
      ORDER SIBLINGS BY name;
NAME    MGR
-----
Kelly   null
Bill    Kelly
Larry   Bill
Scott   Bill
Jackson Kelly
Paul    Jackson
Joe     Kelly
7 rows selected.
```

The following is an example of SELECT statement which uses <group by clause>.

```
gSQL> SELECT ps_partkey, SUM(ps_availqty) FROM partsupp GROUP BY ps_partkey;
PS_PARTKEY SUM(PS_AVAILQTY)
-----
          1          11401
          2           8025
          3          13864
          4          11564
          5           8744
5 rows selected.
```

The following is an example of SELECT statement which uses <having clause>.

```
gSQL> SELECT ps_partkey, SUM(ps_availqty) FROM partsupp GROUP BY ps_partkey having
SUM(ps_availqty) > 10000;
```

```
PS_PARTKEY SUM(PS_AVAILQTY)
```

```
-----
1          11401
3          13864
4          11564
```

```
3 rows selected.
```

## Compatibility

**Table 20-10** SQL standard compatibility

Feature ID	Description	Compatibility
F801	Full set function	X
T051	Row types	X
T301	Functional dependencies	X
T325	Qualified SQL parameter references	X
T053	Explicit aliases for all-fields reference	O
T285	Enhanced derived column names	O

## For More Information

Refer to [query expression](#).

## select list

### Function

It specifies the columns to be retrieved from the query result.

### Syntax

```

<select list> ::=
    <asterisk>
  | <select sublist> [ { <comma> <select sublist> } ... ]
<select sublist> ::=
    <derived column>
  | <qualified asterisk>
<qualified asterisk> ::=
    <asterisked identifier chain> <period> <asterisk>
<asterisked identifier chain> ::=
    <asterisked identifier> [ { <period> <asterisked identifier> } ... ]
<derived column> ::=
    <value expression> [ <as clause> ]
<as clause> ::=
    [ AS ] <column name>

```

### Invocation and Access Rules

If columns or subqueries exist in <select list> statement, the user should satisfy the followings.

- The access privileges for the columns
- The access privileges for the table and columns of the subqueries

### Syntax Rules and Parameters

#### <select list>

It has <asterisk> or <select sublist>.

## <asterisk>

- <asterisk> can be used only alone in <select list>.
  - (O) SELECT \* FROM t1;
  - (X) SELECT \*, c1 FROM t1;

## <select sublist>

- It has <derived column> or <qualified asterisk>.
  - SELECT c1, c2 FROM t1;
  - SELECT t1.\* FROM t1;
- <derived column> can change the output name by using *AS*, and *AS* can be omitted.
  - SELECT c1 AS col1, c2 AS col2 AS FROM t1;
  - SELECT c1 col1, c2 col2 FROM t1;
- If two or more <select sublist> are specified, each <select sublist> should be separated by a comma (,).
  - (O) SELECT c1, c2 FROM t1;
  - (O) SELECT c1, c2, t1.\* FROM t1;
  - (X) SELECT c1 c2 FROM t1;
    - c2 is processed as ALIAS.
  - (X) SELECT c1 c2 c3 FROM t1;

## Description

### <select list>

<select list> specifies the columns to be included in the result set.

### <asterisk>

<asterisk> sets all columns in <from clause> as a select list.

### <select sublist>

<select sublist> has <derived column> or <qualified asterisk>.

- <qualified asterisk>
  - It sets all columns belonging to a specific table or a view as a select list.
- <derived column>
  - It can specifies a column or <value expression>.
  - The column name can be updated by using <as clause>, and *AS* can be omitted.
  - If <from clause> has tables with the same column name, then the table name or the table alias should be specified to refer to that columns.



- SELECT T1.C1, T2.C1 FROM T1, T2;
- SELECT A.C1, B.C1 FROM T1 A, T2 B;

If two or more <select sublist> are specified, each <select sublist> should be separated by a comma (',').

## Names to Be Set in select list

- When <column name> is specified in <derived column>, that name is set as a select list name
  - SELECT i1 AS name FROM t1;
- When <column name> is not specified in <derived column>
  - When <derived column> is a single column reference
    - The column name of a single column is set as a select list name.
    - SELECT i1 FROM t1;
  - If <derived column> is not a column but it is an expression
    - The select list name is not set.
    - SELECT i1 + 100 FROM t1;
    - If it is written in CREATE TABLE AS SELECT clause, the column name should be specified.
    - CREATE TABLE t2 AS SELECT i1 + 100 AS sum\_i1 FROM t1;

## Examples

The following is an example of SELECT statement which uses <asterisk>.

```
gSQL> SELECT * FROM supplier;
S_SUPPKEY S_NAME                S_NATION    S_PHONE
-----
1 Supplier#1          FRANCE      27-918-335-1736
2 Supplier#2          KOREA      15-679-861-2259
3 Supplier#3          GERMANY    11-383-516-1199
4 Supplier#4          UNITED STATES 25-843-787-7479
5 Supplier#5          CANADA     21-151-690-3663
5 rows selected.
```

The following is an example of SELECT statement which uses <select sublist>.

```
gSQL> SELECT revenue.* FROM revenue;
SUPPLIER_NO TOTAL_REVENUE
-----
1          11978.64
2          20321.5
3          41844.68
3 rows selected.
```

```
gSQL> SELECT supplier_no suppno, total_revenue AS TOTAL FROM revenue;
```

```
SUPPNO    TOTAL
```

```
-----
```

```
1 11978.64
```

```
2 20321.5
```

```
3 41844.68
```

```
3 rows selected.
```

```
gSQL> SELECT 1, revenue.*, CAST( total_revenue AS NATIVE_INTEGER ) TOTAL FROM revenue;
```

```
1 SUPPLIER_NO TOTAL_REVENUE TOTAL
```

```
- - - - -
```

```
1          1      11978.64 11979
```

```
1          2      20321.5 20322
```

```
1          3      41844.68 41845
```

```
3 rows selected.
```

## For More Information

Refer to [query specification](#).

# from clause

## Function

It specifies the table which is derived from one or more tables.

## Syntax

```

<from clause> ::=
    FROM <table reference list>
<table reference list> ::=
    <table reference> [ { , <table reference> } ... ]
<table reference> ::=
    <table factor>
    | <joined table>
<table factor> ::=
    <table primary>
<table primary> ::=
    <table name> [ <cluster domain> ] [ [ AS ] <correlation name> ]
    | <derived table> [ <cluster domain> ] [ [ AS ] <correlation name> [ <left paren> <derived
column list> <right paren> ] ]
    | <parenthesized joined table>
<derived table> ::=
    <table subquery>
<parenthesized joined table> ::=
    <left paren> <parenthesized joined table> <right paren>
    | <left paren> <joined table> <right paren>
<derived column list> ::=
    <column name list>
<cluster domain> ::=
    @ <cluster domain name>
<cluster domain name> ::=
    GLOBAL
    | LOCAL
    | LOCAL_OFFLINE
    | <identifier>

```

## Invocation and Access Rules

The access privilege for the table or view specified in `<table reference list>` is required.

## Syntax Rules and Parameters

### `<table reference list>`

- One or more tables can be specified in `<table reference list>` by using a comma (,).
- When two or more tables are specified
  - The evaluation order for the tables is from left to right.
  - When `*` is specified in `<select list>`, the columns are sequentially mapped in `<select list>` from the left table to the right table.

### `<table primary>`

- An alias name can be specified by using `<correlation name>`.
  - `SELECT * FROM t1 AS a, t2 AS b;`
  - `SELECT * FROM ( SELECT i1 FROM t1 ) AS a;`
- `<derived table>` as known as `<table subquery>`
  - can specify an alias name by using `<correlation name>`.
    - `SELECT * FROM ( SELECT i1, i2, i3 FROM t1 ) AS a;`
  - can specify `<derived column list>`.
    - `SELECT * FROM ( SELECT i1, i2, i3 FROM t1 ) AS a( col1, col2, col3 );`
    - The number of `<column name>` in `<derived column list>` should be same as the number of targets in `<select list>` specified in `<table subquery>`.
    - It is sequentially mapped 1 :1 to the target in `<select list>` specified in `<table subquery>`.
    - It should use `<column name>` specified in `<derived column list>` to refer to `<select list>` of `<table subquery>` in that `<derived table>`.

```
SELECT col1, col2
FROM ( SELECT i1, i2 FROM t1 ) AS a( col1, col2 )
WHERE col1 = 1 AND col2 = 1;
```

### `<correlation name>`

- The same `<correlation name>` should not exist two or more in `<table reference list>`.
- When `<correlation name>` is specified, `<correlation name>` should be used to refer to `<table name>` or `<derived table>`.
  - `SELECT a.i1 FROM t1 AS a WHERE a.i1 > 3;`
  - (X) `SELECT t1.i1 FROM t1 AS a WHERE t1.i1 > 3;`

- When specifying <correlation name>, AS can be omitted.
  - SELECT a.i1 FROM t1 a;

## <derived column list>

The same <column name> should not exist two or more in <derived column list>.

## <cluster domain>

- <cluster domain> can be specified in a table, a view, or a table subquery.
  - SELECT \* FROM t1@G1;
  - It can not be specified in <parenthesized joined table>.
    - (X) SELECT \* FROM ( t1 INNER JOIN t2 ON t1.sk = t2.sk )@G2;
- <cluster domain> can not be specified in a table or a view whose structure or data is to be altered.
  - (X) DELETE FROM t2@GLOBAL;
  - (X) UPDATE t1@GLOBAL SET i1 = 1;
  - (X) INSERT INTO t1@GLOBAL VALUES ( 1, 10 );
  - (X) SELECT \* FROM t1@GLOBAL FOR UPDATE;
  - (X) CREATE INDEX t1\_idx ON t1@GLOBAL( i1 );

## <cluster domain name>

Only a cluster group name or a cluster member name can be <identifier> of <cluster domain name>.

- cluster group name
  - SELECT \* FROM t1@G1;
- cluster member name
  - SELECT \* FROM t1@G1N1;

## Description

### <table reference list>

Two or more tables can be specified in <table reference list> by using a comma (,).

- If two or more tables are specified, it operates in the same way as cross join each table from left to right.
  - SELECT \* FROM t1, t2;
  - <=> SELECT \* FROM t1 CROSS JOIN t2;
- If the conditions to join two tables exist in <where clause>, the two tables operate in the same way as inner join which has <where clause> as a join condition.
  - SELECT \* FROM t1, t2 WHERE t1.i1 = t2.i1;
  - <=> SELECT \* FROM t1 INNER JOIN t2 ON t1.i1 = t2.i1;

- If outer join operator (+) is used in <where clause>, it operates in the same way as outer join.
  - For more information about outer join operator (+), refer to **OUTER JOIN**.

## <table reference>

A single table, or view, table subquery, joined table can be <table reference>. Others except for the joined table can have a correlation name.

For more information about joined table, refer to **joined table**.

## <table primary>

The tables, views, table subqueries and <parenthesized joined table> can be <table primary>.

The table, view, table subquery can have a correlation name, and AS can be omitted. If the correlation name is specified, it should be used in everywhere referring to the table, view, table subquery such as <select list>, <where clause>.

The table subquery can specify <derived column list>. The name specified in <derived column list> should be used in everywhere referring to table subquery column as like correlation name. To use <derived column list> in the table subquery, the correlation name should be specified.

<parenthesized joined table> specifies the logical join order for the table participating in the join operation. At this time, if all join operations for the tables enclosed with parentheses are cross join, inner join, the join order can be changed by an optimizer.

## <cluster domain>

When <cluster domain> is omitted, it means the same as using GLOBAL as <cluster domain name>.

For more information, refer to **Cluster Domain**.

## <cluster domain name>

The reserved words defined in <cluster domain name> mean as follows.

- GLOBAL
  - It selects all cluster groups as a cluster domain.
- LOCAL
  - It selects only the server performing the user query as a cluster domain.
    - It brings data of G2N1 when performing the following query in G2N1.
    - `SELECT * FROM t1@LOCAL;`
- LOCAL\_OFFLINE
  - It selects only the server performing the user query as a cluster domain to retrieve the offline table data.
    - It brings data of offline table T1 in G2N1 when performing the following query in G2N1.

- SELECT \* FROM t1@LOCAL\_OFFLINE;
- If LOCAL\_OFFLINE domain is specified in an online table, then an error occurs.

If <identifier> is specified in <cluster domain name>, a cluster group or a cluster member with the corresponding name is selected as **Cluster Domain**.

## Examples

The following is an example of SELECT statement to query a single table by using <table name>.

```
gSQL> SELECT c_name, c_nation FROM customer;
C_NAME      C_NATION
-----
Customer#1  KOREA
Customer#2  CANADA
Customer#3  KOREA
Customer#4  GERMANY
Customer#5  UNITED STATES
5 rows selected.
```

The following is an example of SELECT statement which uses <derived table>.

```
gSQL> SELECT * FROM (SELECT c_name, c_nation FROM customer);
C_NAME      C_NATION
-----
Customer#1  KOREA
Customer#2  CANADA
Customer#3  KOREA
Customer#4  GERMANY
Customer#5  UNITED STATES
5 rows selected.
gSQL> SELECT * FROM (SELECT c_name, c_nation FROM customer) AS CUST ("CUSTOMER_NAME",
"CUSTOMER_NATION");
CUSTOMER_NAME CUSTOMER_NATION
-----
Customer#1    KOREA
Customer#2    CANADA
Customer#3    KOREA
Customer#4    GERMANY
Customer#5    UNITED STATES
5 rows selected.
```

The following is an example of SELECT statement for a joined table which uses parentheses.

```
gSQL> SELECT customer.c_name, o_totalprice FROM (customer INNER JOIN orders ON
customer.c_custkey = orders.o_custkey);
```

```
C_NAME      O_TOTALPRICE
-----
Customer#1  173665.47
Customer#2  46929.18
Customer#4  193846.25
Customer#3  32151.78
Customer#5  144659.2
5 rows selected.
```

The following is an example of SELECT statement which uses two table separated by a comma (,).

```
gSQL> SELECT c_name, o_totalprice FROM customer, orders;
```

```
C_NAME      O_TOTALPRICE
-----
Customer#1  173665.47
Customer#1  46929.18
Customer#1  193846.25
Customer#1  32151.78
Customer#1  144659.2
Customer#2  173665.47
Customer#2  46929.18
Customer#2  193846.25
Customer#2  32151.78
Customer#2  144659.2
Customer#3  173665.47
Customer#3  46929.18
Customer#3  193846.25
Customer#3  32151.78
Customer#3  144659.2
Customer#4  173665.47
Customer#4  46929.18
Customer#4  193846.25
Customer#4  32151.78
Customer#4  144659.2
C_NAME      O_TOTALPRICE
-----
Customer#5  173665.47
```



```
Customer#5      46929.18
Customer#5      193846.25
Customer#5      32151.78
Customer#5      144659.2
25 rows selected.
```

The following is an example of SELECT statement which uses <cluster domain>.

- Using the reserved word GLOBAL

```
gSQL> SELECT * FROM (SELECT c_name, c_nation FROM customer@GLOBAL);
C_NAME      C_NATION
-----
Customer#1  KOREA
Customer#2  CANADA
Customer#3  KOREA
Customer#4  GERMANY
Customer#5  UNITED STATES
5 rows selected.
```

- Using the reserved word LOCAL

```
gSQL> SELECT * FROM (SELECT c_name, c_nation FROM customer)@LOCAL;
C_NAME      C_NATION
-----
Customer#1  KOREA
Customer#2  CANADA
2 rows selected.
```

- Using the cluster group name G1

```
gSQL> SELECT * FROM (SELECT c_name, c_nation FROM customer@G1);
C_NAME      C_NATION
-----
Customer#1  KOREA
Customer#2  CANADA
2 rows selected.
```

- Using the cluster member name G2N1

```
gSQL> SELECT * FROM (SELECT c_name, c_nation FROM customer@G2N1);
C_NAME      C_NATION
```

-----  
Customer#3 KOREA

Customer#4 GERMANY

2 rows selected.

## For More Information

Refer to [subquery](#).

## joined table

### Function

It specifies the table derived from a cartesian product, inner join, outer join.

### Syntax

```

<joined table> ::=
    <cross join>
  | <qualified join>
  | <natural join>
<cross join> ::=
    <table reference> CROSS JOIN <table factor>
<qualified join> ::=
    <table reference> [ <join type> ] JOIN <table reference> <join specification>
<natural join> ::=
    <table reference> NATURAL [ <join type> ] JOIN <table factor>
<join specification> ::=
    <join condition>
  | <named columns join>
<join condition> ::=
    ON <search condition>
<named columns join> ::=
    USING ( <join column list> )
<join type> ::=
    INNER
  | { LEFT | RIGHT | FULL } [ OUTER ]
<join column list> ::=
    <column name list>

```

### Invocation and Access Rules

The access privilege for all tables and views specified in a joined table is required.

### Syntax Rules and Parameters

## <cross join>

<join specification> specifying the join condition does not appear at the location of <cross join>.

A single table, <table subquery> or <parenthesized joined table> can appear on the right of <cross join>.

## <qualified join>

- <join specification> specifying the join condition should be specified.
  - `SELECT * FROM t1 INNER JOIN t2 ON t1.i1 = t2.i1;`
  - `SELECT * FROM t1 INNER JOIN t2 USING ( i1 );`
- <join type> can be omitted, and it is processed as INNER when omitted.
  - `SELECT * FROM t1 JOIN t2 ON t1.i1 = t2.i1;`
  - `<=> SELECT * FROM t1 INNER JOIN t2 ON t1.i1 = t2.i1;`
- OUTER can be omitted in <join type>.
  - `SELECT * FROM t1 LEFT JOIN t2 ON t1.i1 = t2.i1;`
  - `<=> SELECT * FROM t1 LEFT OUTER JOIN t2 ON t1.i1 = t2.i1;`
- If <join type> is OUTER JOIN, then only <join condition> can appear on <join specification>.
  - `SELECT * FROM t1 FULL OUTER JOIN t2 ON t1.i1 = t2.i1;`
  - (X) `SELECT * FROM t1 FULL OUTER JOIN t2 USING ( i1 );`

## <natural join>

- <join specification> specifying the join condition does not appear at the location of <natural join>.
- A single table, <table subquery> or <parenthesized joined table> can appear on the right of <natural join>.
- <join type> can be omitted. When it is omitted, it performs INNER.
  - `SELECT * FROM t1 NATURAL JOIN t2;`
  - `<=> SELECT * FROM t1 NATURAL INNER JOIN t2;`
- It does not allow OUTER in <join type>.
  - (X) `SELECT * FROM t1 NATURAL LEFT OUTER JOIN t2;`
- If the same <column name> does not exist between the left row and right row of NATURAL JOIN, it performs <cross join>.
  - `t1( c1 INTEGER, c2 INTEGER );`
  - `t2( c3 INTEGER, c4 INTEGER );`
  - `SELECT * FROM t1 NATURAL INNER JOIN t2;`
  - `<=> SELECT * FROM t1 CROSS JOIN t2;`
- If the same <column name> exists between the left row and right row of NATURAL JOIN, it is performed as if USING clause is specified.
  - `t1( c1 INTEGER, c2 INTEGER );`
  - `t2( c2 INTEGER, c3 INTEGER );`
  - `SELECT * FROM t1 NATURAL INNER JOIN t2;`
  - `<=> SELECT * FROM t1 INNER JOIN t2 USING( c2 );`

## ⟨join specification⟩

- Only one of ⟨join condition⟩ or ⟨named columns join⟩ can be specified.
  - ⟨join condition⟩
    - `SELECT * FROM t1 INNER JOIN t2 ON t1.i1 = t2.i1;`
  - ⟨named columns join⟩
    - `SELECT * FROM t1 INNER JOIN t2 USING ( i1 );`
- When ⟨named columns join⟩ is specified
  - One or more column name should be specified in ⟨join column list⟩.
    - `SELECT * FROM t1 INNER JOIN t2 USING ( i1 );`
  - The column name can not be specified such as ⟨table name⟩.⟨column name⟩.
    - (X) `SELECT * FROM t1 INNER JOIN t2 USING ( t1.i1 );`
  - The listed columns in ⟨join column list⟩ should be on the left row and right row of JOIN, and they should be able to be compared.
    - `t1( c1 INTEGER, c2 INTEGER );`
    - `t2( c2 INTEGER, c3 INTEGER );`
    - `SELECT * FROM t1 INNER JOIN t2 USING ( c2 );`
  - If \* is used in ⟨select list⟩, then the records are configured as follows.
    - 1) Columns specified in ⟨join column list⟩
    - 2) Columns which does not correspond to ⟨join column list⟩ among left rows.
    - 3) Columns which does not correspond to ⟨join column list⟩ among right rows.
      - `t1( c1 INTEGER, c2 INTEGER );`
      - `t2( c2 INTEGER, c3 INTEGER );`
      - `SELECT * FROM t1 INNER JOIN t2 USING ( c2 );`
      - Record configuration: C2, C1, C3
  - ⟨column name⟩ specified in ⟨join column list⟩ can not be referenced together with ⟨table name⟩.⟨column name⟩, but it can be referenced only by the ⟨column name⟩.
    - `SELECT c2 FROM t1 INNER JOIN t2 USING ( c2 ) WHERE c2 > 3;`
    - (X) `SELECT t1.c2 FROM t1 INNER JOIN t2 USING ( c2 );`
    - (X) `SELECT * FROM t1 INNER JOIN t2 USING ( c2 ) WHERE t1.c2 > 3;`
  - Processing the join condition of ⟨join column list⟩
    - For each column listed in ⟨join column list⟩
    - The condition ⟨left table name⟩.⟨column name⟩ = ⟨right table name⟩.⟨column name⟩ is generated
    - and the conditions to process each ⟨column name⟩ condition using AND are generated.
      - `t1( c1 INTEGER, c2 INTEGER );`
      - `t2( c1 INTEGER, c2 INTEGER );`
      - `SELECT * FROM t1 INNER JOIN t2 USING ( c1, c2 );`
      - Join condition: `t1.c1 = t2.c1 AND t1.c2 = t2.c2`
  - ⟨table name⟩.\* statement which returns all the row for a particular table can not be used in ⟨select list⟩.
    - (X) `SELECT t1.*, t2.* FROM t1 INNER JOIN t2 USING ( c1, c2 );`

## Description

### <cross join>

<cross join> returns a result which combines each left row with all right rows.

```
T1 ( 1, 1 ), ( 2, 2 )
T2 ( 2, 2 ), ( 3, 3 )
gSQL> SELECT * FROM t1 CROSS JOIN t2;
C1 C2 C1 C2
-- -- -- --
 1  1  2  2
 1  1  3  3
 2  2  2  2
 2  2  3  3
4 rows selected.
```

The explicit join condition can not be specified in <cross join>, but the join condition for the two tables can be specified in <where clause>. In this case, it performs inner join.

- `SELECT * FROM t1 CROSS JOIN t2 WHERE t1.c1 = t2.c1;`
- `<=> SELECT * FROM t1 INNER JOIN t2 ON t1.c1 = t2.c1;`

```
T1 ( 1, 1 ), ( 2, 2 )
T2 ( 2, 2 ), ( 3, 3 )
gSQL> SELECT * FROM t1 CROSS JOIN t2 WHERE t1.c1 = t2.c1;
C1 C2 C1 C2
-- -- -- --
 2  2  2  2
1 row selected.
```

### <qualified join>

<qualified join> combines each left row with all right rows, then returns only the rows satisfying the join condition as a result.

If <where clause> exists in <table expression>, then conditions in <where clause> are applied to the result set of <qualified join>.

The result is same, even when inner join processes the conditions in <where clause> as join conditions. But result differs when outer join processes the conditions in <where clause> as join conditions.

**INNER JOIN**

```
t1 ( 1, 1 ), ( 2, 2 ), ( 3, 3 ), ( 4, 4 ), ( 5, 5 )
t2 ( 2, 2 ), ( 3, 3 )
```

- When a condition exists only on ON clause

```
gSQL> SELECT * FROM t1 INNER JOIN t2 ON t1.c1 = t2.c1 AND t1.c2 = t2.c2;
C1 C2 C1 C2
-- -- -- --
 2  2  2  2
 3  3  3  3
2 rows selected.
```

- When a condition exists on ON clause and WHERE clause
  - It applies WHERE condition  $t1.c2 = t2.c2$  to the result set to which JOIN condition ON  $t1.c1 = t2.c1$  is applied.

```
gSQL> SELECT * FROM t1 INNER JOIN t2 ON t1.c1 = t2.c1 WHERE t1.c2 = t2.c2;
C1 C2 C1 C2
-- -- -- --
 2  2  2  2
 3  3  3  3
2 rows selected.
```

- The result set to which JOIN condition ON  $t1.c1 = t2.c1$  is applied → Apply WHERE condition  $t1.c2 = t2.c2$

```
( 2, 2, 2, 2 )          ( 2, 2, 2, 2 )
( 3, 3, 3, 3 )          → ( 3, 3, 3, 3 )
```

**OUTER JOIN**

```
t1 ( 1, 1 ), ( 2, 2 ), ( 3, 3 ), ( 4, 4 ), ( 5, 5 )
t2 ( 2, 2 ), ( 3, 3 )
```

- When a condition exists only on ON clause

```
gSQL> SELECT * FROM t1 LEFT OUTER JOIN t2 ON t1.c1 = t2.c1 AND t1.c2 = t2.c2;
C1 C2  C1  C2
-- --  ----  ----
 1  1 null null
 2  2   2   2
```

```

3 3 3 3
4 4 null null
5 5 null null
5 rows selected.

```

- When a condition exists on ON clause and WHERE clause
  - It applies WHERE condition  $t1.c2 = t2.c2$  to the result set to which JOIN condition ON  $t1.c1 = t2.c1$  is applied.

```

gSQL> SELECT * FROM t1 LEFT OUTER JOIN t2 ON t1.c1 = t2.c1 WHERE t1.c2 = t2.c2;
C1 C2 C1 C2
-- -- -- --
2 2 2 2
3 3 3 3
2 rows selected.

```

- The result set to which JOIN condition ON  $t1.c1 = t2.c1$  is applied → Apply WHERE condition  $t1.c2 = t2.c2$

```

( 1, 1, null, null )
( 2, 2, 2, 2 )           ( 2, 2, 2, 2 )
( 3, 3, 3, 3 )           → ( 3, 3, 3, 3 )
( 4, 4, null, null )
( 5, 5, null, null )

```

Left outer join combines right rows satisfying the join condition for the left rows, then returns the combined rows as a result. If right rows satisfying the join condition does not exist, then it returns the result whose left row values are as they are and whose right row values are filled with NULL.

## LEFT OUTER JOIN

```

t1 ( 1, 1 ), ( 2, 2 )
t2 ( 2, 2 ), ( 3, 3 )
gSQL> SELECT * FROM t1 LEFT OUTER JOIN t2 ON t1.c1 = t2.c1;
C1 C2 C1 C2
-- -- ---- ----
1 1 null null
2 2 2 2
2 rows selected.

```

Right outer join is operated in an opposite way of left outer join.



## RIGHT OUTER JOIN

```
t1 ( 1, 1 ), ( 2, 2 )
```

```
t2 ( 2, 2 ), ( 3, 3 )
```

```
gSQL> SELECT * FROM t1 RIGHT OUTER JOIN t2 ON t1.c1 = t2.c1;
```

```
  C1   C2  C1  C2
```

```
-----
```

```
  2    2  2  2
```

```
 null null 3  3
```

```
2 rows selected.
```

Full outer join returns the left rows filled with NULL for all right rows which do not satisfy the join condition together with left outer join results.

## FULL OUTER JOIN

```
t1 ( 1, 1 ), ( 2, 2 )
```

```
t2 ( 2, 2 ), ( 3, 3 )
```

```
gSQL> SELECT * FROM t1 FULL OUTER JOIN t2 ON t1.c1 = t2.c1;
```

```
  C1   C2   C1   C2
```

```
-----
```

```
  1    1 null null
```

```
  2    2   2   2
```

```
 null null   3   3
```

```
3 rows selected.
```

## &lt;natural join&gt;

<natural join> joins all columns with same names in two tables participating in join as equal. In other words, it is as same as specifying all columns with same names of two tables participating in join in USING clause of inner join.

```
t1 ( C1 INTEGER, C2 INTEGER )
```

```
t2 ( C1 INTEGER, C3 INTEGER )
```

```
t1 ( 1, 10 ), ( 2, 20 ), ( 3, 30 )
```

```
t2 ( 1, 100 ), ( 2, 200 ), ( 3, 300 )
```

```
gSQL> SELECT * FROM t1 NATURAL JOIN t2;
```

```
 C1  C2  C3
```

```
-- -- ---
```

```
  1  10 100
```

```
  2  20 200
```

```
  3  30 300
```

```
3 rows selected.
```

```
gSQL> SELECT * FROM t1 INNER JOIN t2 USING ( c1 );
```

```

C1 C2 C3
-- -- ---
 1 10 100
 2 20 200
 3 30 300
3 rows selected.

```

## ⟨join specification⟩

It specifies the join condition.

⟨join condition⟩ specifies the condition for joining left rows and right rows of a join statement.

⟨named columns join⟩ specifies the join condition by listing that ⟨column name⟩, if the same ⟨column name⟩ exist in left rows and right rows.

```

t1 ( C1 INTEGER, C2 INTEGER )
t2 ( C1 INTEGER, C3 INTEGER )
t1 ( 1, 10 ), ( 2, 20 ), ( 3, 30 )
t2 ( 1, 100 ), ( 2, 200 ), ( 3, 300 )
• ⟨join condition⟩
gSQL> SELECT * FROM t1 INNER JOIN t2 ON t1.c1 = t2.c1;
C1 C2 C1 C3
-- -- -- ---
 1 10  1 100
 2 20  2 200
 3 30  3 300
3 rows selected.
• ⟨named columns join⟩
gSQL> SELECT * FROM t1 INNER JOIN t2 USING ( c1 );
C1 C2 C3
-- -- ---
 1 10 100
 2 20 200
 3 30 300
3 rows selected.

```

## Examples

The following is an example of SELECT statement which uses ⟨cross join⟩.

```

gSQL> SELECT c_name, o_totalprice FROM customer CROSS JOIN orders;
C_NAME      O_TOTALPRICE

```

```

-----
Customer#1    173665.47
Customer#1    46929.18
Customer#1    193846.25
Customer#1    32151.78
Customer#1    144659.2
Customer#2    173665.47
Customer#2    46929.18
Customer#2    193846.25
Customer#2    32151.78
Customer#2    144659.2
Customer#3    173665.47
Customer#3    46929.18
Customer#3    193846.25
Customer#3    32151.78
Customer#3    144659.2
Customer#4    173665.47
Customer#4    46929.18
Customer#4    193846.25
Customer#4    32151.78
Customer#4    144659.2
C_NAME      O_TOTALPRICE
-----
Customer#5    173665.47
Customer#5    46929.18
Customer#5    193846.25
Customer#5    32151.78
Customer#5    144659.2
25 rows selected.

```

The following is an example of SELECT statement which uses inner join.

```

gSQL> SELECT c_name, o_totalprice FROM customer INNER JOIN orders ON c_custkey = o_custkey;
C_NAME      O_TOTALPRICE
-----
Customer#1    173665.47
Customer#2    46929.18
Customer#4    193846.25
Customer#3    32151.78
Customer#5    144659.2
5 rows selected.

```

The following is an example of SELECT statement which uses outer join.

```
gSQL> SELECT c_name, o_totalprice FROM customer LEFT OUTER JOIN orders ON c_custkey =
o_custkey AND o_orderdate < '1996-01-01';
```

```
C_NAME      O_TOTALPRICE
```

```
-----
```

```
Customer#1      null
```

```
Customer#2      null
```

```
Customer#3      32151.78
```

```
Customer#4      193846.25
```

```
Customer#5      144659.2
```

```
5 rows selected.
```

```
gSQL> SELECT c_name, o_totalprice FROM customer RIGHT OUTER JOIN orders ON c_custkey =
o_custkey AND c_nation = 'KOREA';
```

```
C_NAME      O_TOTALPRICE
```

```
-----
```

```
Customer#1      173665.47
```

```
null           46929.18
```

```
null           193846.25
```

```
Customer#3      32151.78
```

```
null           144659.2
```

```
5 rows selected.
```

```
gSQL> SELECT c_name, o_totalprice FROM customer FULL OUTER JOIN orders ON c_custkey =
o_custkey AND c_nation = 'KOREA' AND o_orderdate < '1996-01-01';
```

```
C_NAME      O_TOTALPRICE
```

```
-----
```

```
Customer#1      null
```

```
Customer#2      null
```

```
Customer#3      32151.78
```

```
Customer#4      null
```

```
Customer#5      null
```

```
null           173665.47
```

```
null           46929.18
```

```
null           193846.25
```

```
null           144659.2
```

```
9 rows selected.
```

The following is an example of SELECT statement which uses natural join.

```
gSQL> SELECT c_name, o_totalprice FROM (SELECT c_custkey custkey, c_name FROM customer)
NATURAL JOIN (SELECT o_custkey custkey, o_totalprice FROM orders);
```

```
C_NAME      O_TOTALPRICE
-----      -
Customer#1  173665.47
Customer#2  46929.18
Customer#4  193846.25
Customer#3  32151.78
Customer#5  144659.2
5 rows selected.
```

## Compatibility

Table 20-11 SQL standard compatibility

Feature ID	Description	Compatibility
F401	Extended joined table	O
F402	Named column joins for LOBs, arrays, and multisets	X
F403	Partitioned join tables	X

## For More Information

Refer to `from` clause.

# where clause

## Function

It applies <search condition> to the result of <from clause>.

## Syntax

```
<where clause> ::=
    WHERE <search condition>
```

## Syntax Rules and Parameters

### <where clause>

<search condition> which returns a boolean type is required after WHERE keyword.

## Description

For more information about <where clause>, refer to **Conditions**.

## Example

The following is an example of SELECT statement which uses <where clause>.

```
gSQL> SELECT s_name, s_nation FROM supplier WHERE s_nation = 'KOREA';
S_NAME                S_NATION
-----
Supplier#2            KOREA
1 row selected.
gSQL> SELECT s_name, ps_availqty, ps_supplycost FROM supplier, partsupp WHERE s_nation =
'KOREA' AND s_suppkey = ps_suppkey;
S_NAME                PS_AVAILQTY PS_SUPPLYCOST
-----
Supplier#2            8076        993.49
Supplier#2            4069        357.84
2 rows selected.
```

## Compatibility

Table 20-12 SQL standard compatibility

Feature ID	Description	Compatibility
F441	Extended set function support	O

## For More Information

Refer to [query specification](#).

## hierarchical query clause

### Function

It specifies to retrieve the hierarchical model data in a hierarchy.

It returns table records in a hierarchy of depth-first sequence by using the launch condition and sub-connectivity condition.

### Syntax

```

<hierarchical query clause> ::=
    <start with connect by clause> [ <order siblings by clause> ]
<start with connect by clause> ::=
    <start with clause> <connect by clause>
    | <connect by clause> <start with clause>
    | <connect by clause>
<start with clause> ::=
    START WITH <start_with_condition>
<connect by clause> ::=
    CONNECT BY [NOCYCLE] <connect_by_condition>
<order siblings by clause> ::=
    ORDER SIBLINGS BY <ordering element> [ { <comma> <ordering element> }... ]
<ordering element> ::=
    <value expression> [ASC | DESC] [NULLS FIRST | NULLS LAST]
<hierarchy expression> ::=
    LEVEL
    | CONNECT_BY_ISCYCLE
    | CONNECT_BY_ISLEAF
    | PRIOR <value expression>
    | CONNECT_BY_ROOT <value expression>
    | SYS_CONNECT_BY_PATH <left paren> <value expression> <comma> <character string literal>
    <right paren>

```

### Invocation and Access Rules

It is supported in <query specification> statement, and the user should satisfy the access privilege of <query specification> to perform it.

For more information, refer to **query specification**.



## Syntax Rules and Parameters

### ⟨hierarchical query clause⟩

⟨connect by clause⟩ should be described.

⟨start with clause⟩ or ⟨order siblings by clause⟩ is described when it is required.

### ⟨start with clause⟩

It specifies the condition of root record in data hierarchy.

When it is not specified, then all records of from clause become targets of root records.

It can be described only once within SELECT statement.

### ⟨connect by clause⟩

It describes the relation between the parent record and the child record.

It expresses the relation between the parent record and the child record by using PRIOR operator which represents the column value of the parent record.

If the condition of connecting the parent record and the child record is not specified by using PRIOR operator, then an infinite loop may occur.

It can be described only once within SELECT statement.

- NOCYCLE
  - When NOCYCLE option is not specified
    - When cycle occurs, then that query causes an error and the execution stops.
  - When NOCYCLE option is specified
    - When cycle occurs, then that query does not cause an error.
    - The record which caused cycle stops retrieving the child record and it is not included in the result record.
    - The query continuously proceeds for sibling rows where cycle does not occur.
    - 1 is stored in CONNECT\_BY\_ISCYCLE of the parent record of the record which caused cycle.
    - 0 is stored in CONNECT\_BY\_ISCYCLE of the parent record of the record which has not caused cycle.

### ⟨order siblings by clause⟩

It specifies the order of fetching sibling records of the same parent records.

- Sort order
  - ASC
  - DESC
  - If not specified, the default value is ASC.

- Null ordering
  - NULLS FIRST
  - NULLS LAST
  - If not specified, the default value is NULLS LAST.

**<hierarchy expression>**

- The following hierarchy information is acquired when configuring the hierarchy query.
  - LEVEL
  - CONNECT\_BY\_ISCYCLE
  - CONNECT\_BY\_ISLEAF
  - PRIOR
  - CONNECT\_BY\_ROOT
  - SYS\_CONNECT\_BY\_PATH

**Table 20-13** Result type of <hierarchy expression>

Expression	Result DataType
LEVEL	NATIVE_BIGINT
CONNECT_BY_ISCYCLE	NATIVE_BIGINT
CONNECT_BY_ISLEAF	NATIVE_BIGINT
PRIOR expr	expr의 DataType
CONNECT_BY_ROOT expr	expr의 DataType
SYS_CONNECT_BY_PATH( expr, literal )	VARCHAR(4000 characters)

<hierarchy expression> can be described in the following statements.

Expression Use	FROM	START WITH	CONNECT BY	ORDER SIBLINGS BY	WHERE/ GROUP BY/ HAVING	ORDER BY/ SELECT TARGET
LEVEL	X	O	O	X	O	O
CONNECT_BY_ISCYCLE	X	X	X	X	O	O
CONNECT_BY_ISLEAF	X	X	X	X	O	O
PRIOR	X	X	O	X	O	O
CONNECT_BY_ROOT	X	X	X	X	O	O
SYS_CONNECT_BY_PATH	X	X	X	X	O	O

Whether <hierarchy expression> can be used as an argument of <hierarchy expression> is described in the following table.

Expression Argument(expr)	LEVEL	CONNECT_BY _JSCYCLE	CONNECT_BY _JSLAF	PRIOR	CONNECT_BY _ROOT	SYS_CONNEC T_BY_PARTH
PRIOR expr	X	X	X	X	X	X
CONNECT_BY _ROOT expr	X	X	X	X	X	X
SYS_CONNEC T_BY_PARTH (expr,literal)	O	O	O	O	O	O

## Description

⟨hierarchical query clause⟩ retrieves the hierarchical model data in a hierarchy.

It returns table records in a hierarchy of depth-first sequence by using the launch condition and sub-connectivity condition.

When ⟨hierarchical query clause⟩ is described in SELECT, then it is processed in the following order.

1. ON condition in FROM clause
2. START WITH
3. CONNECT BY
4. WHERE

- When only a single table exists in *from* clause

```
SELECT *
  FROM r_region
 WHERE r_population > 10000000      ③ Condition in WHERE clause
 START WITH r_name = 'EARTH'       ① START WITH
 CONNECT BY r_domain = PRIOR r_name ② CONNECT BY
```

- When join condition configured with multiple tables exists in *from* clause
  - When join condition is described in ON clause of FROM clause

```
SELECT *
  FROM r_region INNER JOIN s_region
      ON r_id = s_id                ① Join condition in ON clause
 WHERE r_population > 10000000     ④ Condition in WHERE clause
 START WITH r_name = 'EARTH'       ② START WITH
 CONNECT BY r_domain = PRIOR r_name ③ CONNECT BY
```

- When join condition is described in WHERE clause

```

SELECT *
  FROM r_region, s_region
 WHERE r_population > 100000000
    AND r_id = s_id
START WITH r_name = 'EARTH'
CONNECT BY r_domain = PRIOR r_name

```

- ③ Condition in WHERE clause
- ③ Join condition in WHERE clause
- ① START WITH
- ② CONNECT BY

- When join condition is described in both ON clause of FROM and in WHERE clause

```

SELECT *
  FROM r_region INNER JOIN s_region
    ON r_name = s_name
 WHERE r_population > 100000000
    AND r_id = s_id
START WITH r_name = 'EARTH'
CONNECT BY r_domain = PRIOR r_name

```

- ① Join condition in ON clause
- ④ Condition in WHERE clause
- ④ Join condition in WHERE clause
- ② START WITH
- ③ CONNECT BY

## <order siblings by clause>

It specifies the order of fetching sibling records of the same parent records within <hierarchical query clause>.

<order siblings by clause> is a statement distinct from <order by clause>.

```

gSQL>
SELECT * FROM t1;
I1 I2
--- ----
A  null
AA A
AB A
fAA AA
eAA AA
bAA AA
dAB AB
cAB AB
aAB AB
9 rows selected.

```

- The following is an example of defining the order of fetching sibling records of the same parent records.

```

gSQL>
SELECT LEVEL, i1, i2
  FROM t1
START WITH i1 = 'A'
CONNECT BY i2 = PRIOR i1
ORDER SIBLINGS BY i1;
LEVEL I1  I2
-----
 1 A    null
 2 AA   A
 3 bAA  AA
 3 eAA  AA
 3 fAA  AA
 2 AB   A
 3 aAB  AB
 3 cAB  AB
 3 dAB  AB
9 rows selected.

```

- The following is an example of sorting all results retrieved in a hierarchy by using ORDER BY clause in an order of LEVEL.

```

gSQL>
SELECT LEVEL, i1, i2
  FROM t1
START WITH i1 = 'A'
CONNECT BY i2 = PRIOR i1
ORDER SIBLINGS BY i1
ORDER BY LEVEL;
LEVEL I1  I2
-----
 1 A    null
 2 AA   A
 2 AB   A
 3 bAA  AA
 3 eAA  AA
 3 fAA  AA
 3 aAB  AB
 3 cAB  AB
 3 dAB  AB
9 rows selected.

```

## <hierarchy expression>

The followings are features of the hierarchy expression.

- PRIOR
  - It acquires the information based on the parent record of the current record.
  - PRIOR is a unary operator, and its priority is as same as that of a unary operator +, -.

```
gSQL>
SELECT i1, i2
  FROM t1
START WITH i1 = 'X'
CONNECT BY i2 = PRIOR i1;
I1    I2
-----
X     null
XA    X
XXA   XA
XXXXA XXXA
XXXXA XXXA
5 rows selected.
```

- LEVEL
  - It is the hierarchical value in which the record belongs.
  - LEVEL of the root record is 1, and LEVEL of the child record of the root is 2.
  - LEVEL increases by 1 as it goes down to the child record.

```
gSQL>
SELECT LEVEL, i1, i2
  FROM t1
START WITH i1 = 'X'
CONNECT BY i2 = prior i1;
LEVEL I1    I2
-----
1 X     null
2 XA    X
3 XXA   XA
4 XXXA  XXXA
5 XXXA  XXXA
5 rows selected.
```

- CONNECT\_BY\_ISCYCLE

- It acquires the information about whether the record causing cycle exists among child records related to the current record.
- It is available only when NOCYCLE exists in CONNECT BY statement.

```

gSQL>
SELECT * FROM t1;
I1 I2
-- ----
A null
AA A
AB A
AC A
AA AA
AB AA
6 rows selected.

gSQL>
SELECT i1, i2, CONNECT_BY_ISCYCLE
FROM t1
START WITH i1 = 'A'
CONNECT BY NOCYCLE i2 = prior i1;
I1 I2 CONNECT_BY_ISCYCLE
-- ---- -----
A null 0
AA A 1
AB AA 0
AB A 0
AC A 0
5 rows selected.

```

- CONNECT\_BY\_ISLEAF
  - It acquires the information about whether the child record related to the current record exists.
  - If the child record related to the current record does not exist, then it returns 1.

```

gSQL>
SELECT i1, i2, CONNECT_BY_ISLEAF
FROM t1
START WITH i1 = 'X'
CONNECT BY i2 = prior i1;
I1 I2 CONNECT_BY_ISLEAF
----- ---- -----
X null 0
XA X 0

```

```

XXA  XA          0
XXXXA XXXA      0
XXXXA XXXA      1
5 rows selected.

```

- CONNECT\_BY\_ROOT
  - It acquires the information based on the root record of the current record.

```

gSQL>
SELECT i1, i2, CONNECT_BY_ROOT i1
FROM t1
START WITH i1 = 'X'
CONNECT BY i2 = prior i1;
I1  I2  CONNECT_BY_ROOT I1
-----
X   null X
XA  X   X
XXA XA  X
XXXXA XXXA X
XXXXA XXXA X
5 rows selected.

```

- SYS\_CONNECT\_BY\_PATH
  - It acquires the information by recursively searching along the parent record of the current record.

```

gSQL>
SELECT i1, i2, SYS_CONNECT_BY_PATH( i1, '/' )
FROM t1
START WITH i1 = 'X'
CONNECT BY i2 = prior i1;
I1  I2  SYS_CONNECT_BY_PATH( I1, '/' )
-----
X   null /X
XA  X   /X/XA
XXA XA  /X/XA/XXA
XXXXA XXXA /X/XA/XXA/XXXXA
XXXXA XXXA /X/XA/XXA/XXXXA/XXXXA
5 rows selected.

```



## Examples

The following is the result of retrieving record in emp table which will be used in the example of hierarchical query clause.

```
gSQL>
SELECT * FROM emp;
NAME      MGR
-----  -----
Kelly     null
Bill      Kelly
Jackson   Kelly
Joe       Kelly
Scott     Bill
Larry     Bill
Paul      Jackson
Bill      Bill
8 rows selected.
```

The following is an example of when cycle occurs.

```
gSQL>
SELECT *
  FROM emp
START WITH mgr IS NULL
CONNECT BY mgr = PRIOR name
ORDER SIBLINGS BY name;
ERR-42000(16511): cycle detected while executing recursive WITH query
```

The following is an example of executing the query by using CONNECT BY NOCYCLE statement.

```
gSQL>
SELECT *
  FROM emp
START WITH mgr IS NULL
CONNECT BY NOCYCLE mgr = PRIOR name
ORDER SIBLINGS BY name;
NAME      MGR
-----  -----
Kelly     null
Bill      Kelly
Larry     Bill
```

```

Scott  Bill
Jackson Kelly
Paul   Jackson
Joe    Kelly
7 rows selected.

```

The following is an example of retrieving the information about the hierarchical data by using the hierarchy expression.

```

gSQL>
SELECT name,
       mgr,
       PRIOR name AS prior_mgr,
       LEVEL,
       CONNECT_BY_ISCYCLE AS iscycle,
       CONNECT_BY_ISLEAF AS isleaf,
       CONNECT_BY_ROOT mgr AS root_mgr,
       SYS_CONNECT_BY_PATH( mgr, '/' ) AS path
FROM emp
START WITH mgr IS NULL
CONNECT BY NOCYCLE mgr = PRIOR name
ORDER SIBLINGS BY name;

```

NAME	MGR	PRIOR_MGR	LEVEL	ISCYCLE	ISLEAF	ROOT_MGR	PATH
Kelly	null	null	1	0	0	null	/
Bill	Kelly	Kelly	2	1	0	null	//Kelly
Larry	Bill	Bill	3	0	1	null	//Kelly/Bill
Scott	Bill	Bill	3	0	1	null	//Kelly/Bill
Jackson	Kelly	Kelly	2	0	0	null	//Kelly
Paul	Jackson	Jackson	3	0	1	null	//Kelly/Jackson
Joe	Kelly	Kelly	2	0	1	null	//Kelly

```

7 rows selected.

```

## group by clause

### Function

It specifies the grouped table of which `<group by clause>` was applied to the result processed by the previous statements.

### Syntax

```

<group by clause> ::=
    GROUP BY <grouping element list>
<grouping element list> ::=
    <grouping element> [ { , <grouping element> } ... ]
<grouping element> ::=
    <ordinary grouping set>
    | <empty grouping set>
<ordinary grouping set> ::=
    <grouping column reference>
<grouping column reference> ::=
    <column reference>
    | <value_expression>
<empty grouping set> ::=
    <left paren> <right paren>

```

### Invocation and Access Rules

Any separate access privilege is not required for a user to perform `<group by clause>`.

### Syntax Rules and Parameters

#### `<ordinary grouping set>`

It consists of one or more `<grouping column reference>`.

It does not support LONG type (LONG VARCHAR, LONG VARBINARY).

- `SELECT c1, sum(c2) FROM t1 GROUP BY c1;`
- `SELECT sum(c1) FROM t1 GROUP BY NULL;`

## ⟨empty grouping set⟩

It can be specified by using only parentheses.

- `SELECT sum(c1) FROM t1 GROUP BY ();`

## Description

### ⟨grouping element list⟩

It groups ⟨grouping element list⟩ specified in ⟨group by clause⟩ into a GROUPING SET. If all values of ⟨grouping element⟩ in GROUPING SET are matched, it is processed as the same group.

- If ⟨group by clause⟩ is specified, the following expressions can appear in ⟨select list⟩.
  - Constant number
  - ⟨grouping column reference⟩ specified in ⟨group by clause⟩
  - Operation expression including ⟨grouping column reference⟩ specified in ⟨group by clause⟩
  - Aggregation function of a column which is not specified in ⟨group by clause⟩
  - `SELECT c1, sum(c2) FROM t1 GROUP BY c1;`

### ⟨grouping column reference⟩

⟨column reference⟩ or ⟨value expression⟩ can appear in ⟨grouping column reference⟩.

- ⟨column reference⟩
  - Only the columns belonging to ⟨from clause⟩ of ⟨query specification⟩ can be referenced.
    - `SELECT c1 FROM t1 GROUP BY c1;`
  - If same column names exist, then clearly specify the column name by using a table name.
    - `SELECT t1.c1, t2.c1 FROM t1, t2 GROUP BY t1.c1, t2.c1;`
- ⟨value expression⟩
  - It is an expression which includes ⟨column reference⟩.
    - It can be divided into several groups by using ⟨column reference⟩
    - `SELECT sum(c2) FROM t1 GROUP BY c1 + 10;`
  - It is an expression which does not include ⟨column reference⟩.
    - Values in ⟨value expression⟩ are all same constants, so all records are configured into a single group.
    - If null is specified in ⟨value expression⟩, the null values are treated as the same value, so all records are configured into a single group.
    - `SELECT sum(c1), sum(c2) FROM t1 GROUP BY NULL;`

## ⟨empty grouping set⟩

All records in ⟨empty grouping set⟩ are configured into a single group.

- `SELECT sum(c1), sum(c2) FROM t1 GROUP BY ();`

## Example

The following is an example of SELECT statement which uses GROUP BY clause.

```
gSQL> SELECT c_nation, COUNT(c_name) FROM customer GROUP BY c_nation;
```

```
C_NATION      COUNT(C_NAME)
```

```
-----
```

```
UNITED STATES      1
```

```
CANADA             1
```

```
KOREA              2
```

```
GERMANY            1
```

4 rows selected.

```
gSQL> SELECT COUNT(c_name) FROM customer GROUP BY NULL;
```

```
COUNT(C_NAME)
```

```
-----
```

```
5
```

1 row selected.

```
gSQL> SELECT COUNT(c_name) FROM customer GROUP BY ();
```

```
COUNT(C_NAME)
```

```
-----
```

```
5
```

1 row selected.

## Compatibility

**Table 20-14** SQL standard compatibility

Feature ID	Description	Compatibility
T431	Extended grouping capabilities	X
T432	Nested and concatenated GROUPING SETS	X
T434	GROUP BY DISTINCT	X

## For More Information

Refer to the followings.

- **having clause**
- **query specification**

# having clause

## Function

It specifies grouped tables having removed groups which do not satisfy <search condition>.

## Syntax

```
<having clause> ::=  
    HAVING <search condition>
```

## Invocation and Access Rules

Any separate access privilege is not required for a user to perform <having clause>.

## Syntax Rules and Parameters

### <having clause>

- What can be used without aggregate functions in <search condition> is only <grouping column reference> specified in <group by clause>.
  - SELECT c1, sum(c2) FROM t1 GROUP BY c1 HAVING c1 > 3;
- The columns which are not specified in <group by clause> can be specified by using aggregate functions.
  - SELECT c1, sum(c2) FROM t1 GROUP BY c1 HAVING sum(c2) > 100;

## Description

### <having clause>

<having clause> specifies search conditions for the grouped data.

Generally, it is used together with <group by clause>. When <having clause> is used without <group by clause>, it is considered as if <empty grouping set> exists.

- SELECT sum(c1), sum(c2) FROM t1 HAVING sum(c1) > 0;
- <=> SELECT sum(c1), sum(c2) FROM t1 GROUP BY () HAVING sum(c1) > 0;

<grouping column reference> specified in <group by clause> can be specified in <having clause>.

The columns which are not specified in <group by clause> can be specified by using aggregate functions.

- `SELECT c1, sum(c2) FROM t1 GROUP BY c1 HAVING c1 > 3 AND sum(c2) > 100;`

## Example

The following is an example of SELECT statement which uses <having clause>.

```
gSQL> SELECT c_nation, COUNT(c_name) FROM customer GROUP BY c_nation HAVING COUNT(c_name) > 1;
C_NATION COUNT(C_NAME)
-----
KOREA          2
1 row selected.
gSQL> SELECT COUNT(c_name) FROM customer HAVING COUNT(c_name) > 1;
COUNT(C_NAME)
-----
5
1 row selected.
```

## Compatibility

**Table 20-15** SQL standard compatibility

Feature ID	Description	Compatibility
T301	Functional dependencies	O

## For More Information

Refer to the followings.

- [group by clause](#)
- [Conditions](#)



# order by clause

## Function

It specifies the sorting order of the query results.

## Syntax

```

<order by clause> ::=
    ORDER BY <sort specification list>
<sort specification list> ::=
    <sort specification> [ { <comma> <sort specification> }... ]
<sort specification> ::=
    <sort key> [ <ordering specification> ] [ <null ordering> ]
<sort key> ::=
    <value expression>
<ordering specification> ::=
    ASC
    | DESC
<null ordering> ::=
    NULLS FIRST
    | NULLS LAST
  
```

## Invocation and Access Rules

The access privilege for a column is required if the column exist in a sort key specified for sorting.

## Syntax Rules and Parameters

### <order by clause>

- When <set quantifier> DISTINCT is specified in <query specification>, then only the expression specified in <select list> can appear in <sort key>.
  - SELECT DISTINCT c1, c2 FROM t1 ORDER BY c1;
  - (X) SELECT DISTINCT c1, c2 FROM t1 ORDER BY c5;
- When one or more <set function specification> are specified in <select list> of <query specification>, then only the expression specified in <select list> can appear in <sort key>.
  - SELECT c1, sum(c2) FROM t1 GROUP BY c1 ORDER BY c1;
  - (X) SELECT c1, sum(c2) FROM t1 GROUP BY c1 ORDER BY c5;

- If `<order by clause>` is specified in `<set operator>`, `<sort key>` is analysed based on the firstly specified `<query specification>`.
  - `SELECT c1, c2 FROM t1 UNION SELECT i1, i2 FROM t3 ORDER BY c1, c2;`
  - `(X) SELECT c1, c2 FROM t1 UNION SELECT i1, i2 FROM t3 ORDER BY i1, i2;`

### `<sort specification list>`

- `<ordering specification>`
  - ASC
  - DESC
  - If it is not specified, the default value is ASC.
- `<>null ordering>`
  - NULLS FIRST
  - NULLS LAST
  - If it is not specified, the default value is NULLS LAST.

### `<sort key>`

- If `<value expression>` of `<sort key>` is the positive integer value, the value is used as a sort key index.
  - The *i*-th `<select sublist>` of `<query specification>` which corresponds to the value is used as a sort key.
    - `SELECT c1, c2 FROM t1 ORDER BY 1;`
    - C1 is sorted by the sort key.
  - If the *i*-th `<select sublist>` of `<query specification>` which corresponds to the value does not exist, it returns an error.
    - `(X) SELECT c1, c2 FROM t1 ORDER BY 3;`
- A row subquery or relation subquery is not supported as `<value expression>`.
  - `(X) SELECT c1, c2 FROM t1 ORDER BY ( SELECT i1, i2 FROM t2 FETCH FIRST ROW ONLY );`
  - Multiple records exist in T2.
    - `(X) SELECT c1, c2 FROM t1 ORDER BY ( SELECT i1 FROM t2 );`
- Other `<value expression>` are used as sort keys.

## Description

### `<order by clause>`

`<order by clause>` specifies a method to sort the query results.

`<sort key>` can be listed in `<order by clause>` by using a comma (,), and `<sort key>` of each records are compared and listed in order.

```
SELECT c1, c2 FROM t1 ORDER BY c1, c2;
```

<ordering specification> which specifies an ascending order or an descending order can be specified in <sort key>. If it is omitted, then they are sorted in an ascending order.

```
gSQL> SELECT c1 FROM t1;
```

```
C1
```

```
--
```

```
2
```

```
3
```

```
1
```

```
3 rows selected.
```

- Ascending order (ASC)

```
gSQL> SELECT c1 FROM t1 ORDER BY c1;
```

```
C1
```

```
--
```

```
1
```

```
2
```

```
3
```

```
3 rows selected.
```

```
gSQL> SELECT c1 FROM t1 ORDER BY c1 ASC;
```

```
C1
```

```
--
```

```
1
```

```
2
```

```
3
```

```
3 rows selected.
```

- Descending order (DESC)

```
gSQL> SELECT c1 FROM t1 ORDER BY c1 DESC;
```

```
C1
```

```
--
```

```
3
```

```
2
```

```
1
```

```
3 rows selected.
```

<null ordering> specifies an order between the non-NULL values and NULL values in <sort key>. If it is omitted, then they are sorted as NULLS LAST.

```
gSQL> SELECT c1 FROM t1;
  C1
----
  2
null
  1
3 rows selected.
```

- NULLS LAST

```
gSQL> SELECT c1 FROM t1 ORDER BY c1;
  C1
----
  1
  2
null
3 rows selected.
gSQL> SELECT c1 FROM t1 ORDER BY c1 NULLS LAST;
  C1
----
  1
  2
null
3 rows selected.
```

- NULLS FIRST

```
gSQL> SELECT c1 FROM t1 ORDER BY c1 NULLS FIRST;
  C1
----
null
  1
  2
3 rows selected.
```

If a constant value is specified in <sort key>, the expression positioned in the location corresponding to the order of the corresponding value in <select list> is regarded as <sort key>. In this case, the constant is an integer bigger than 0, and it should be equal or smaller than the total number of expression in <select list>

```
gSQL> SELECT c1 FROM t1 ORDER BY 1;
  C1
----
   1
   2
 null
3 rows selected.
```

LONG (LONG VARCHAR, LONG VARBINARY) type can not be specified in <sort key>.

## Comparison of Null Value

- The comparison between null values is regarded as the same value.
- The comparison between non-null value and null value is subject to the following rules.
  - When it is NULLS FIRST and ASC: null value < not null value
  - When it is NULLS LAST and ASC: null value > not null value
  - When it is NULLS FIRST and DESC: null value > not null value
  - When it is NULLS LAST and DESC: null value < not null value
- If the comparison result between null values is UNKNOWN, it is sorted according to the scan order.

## Sorting Rows Which Have Same Sort Key Value

Peers are rows which can not be distinguished by a sort key, and the peers are sorted according to the scan order.

## <aggregation function> Which Is Used As <sort key>

If <aggregation function> is used in <query specification>, or <group by clause> is specified, <aggregation function> can be used as <sort key>.

However, the nested aggregation function can be used as <sort key> only when <group by clause> is specified.

```
gSQL> SELECT c1, c2 FROM t1;
  C1 C2
-- --
  2  1
  3  5
  1  2
  2 10
  3 10
5 rows selected.
gSQL> SELECT sum(c1) FROM t1 ORDER BY sum(c1);
```

```

SUM(C1)
-----
      11
1 row selected.
gSQL> SELECT c1, sum(c2) FROM t1 GROUP BY c1 ORDER BY sum(c2);
C1 SUM(C2)
-- -----
1      2
2     11
3     15
3 rows selected.
gSQL> SELECT sum(c1) FROM t1 GROUP BY c1 ORDER BY sum(sum(c1));
SUM(C1)
-----
      6
1 row selected.

```

## Example

The following is an example of SELECT statement which uses ORDER BY clause.

```

gSQL> SELECT c_name, c_nation FROM customer ORDER BY c_nation;
C_NAME      C_NATION
-----
Customer#2  CANADA
Customer#4  GERMANY
Customer#1  KOREA
Customer#3  KOREA
Customer#5  UNITED STATES
5 rows selected.
gSQL> SELECT c_name, c_nation FROM customer ORDER BY c_nation DESC;
C_NAME      C_NATION
-----
Customer#5  UNITED STATES
Customer#1  KOREA
Customer#3  KOREA
Customer#4  GERMANY
Customer#2  CANADA
5 rows selected.
gSQL> SELECT c_name, c_nation FROM customer ORDER BY 2 DESC;
C_NAME      C_NATION
-----

```

```
-----  
Customer#5 UNITED STATES  
Customer#1 KOREA  
Customer#3 KOREA  
Customer#4 GERMANY  
Customer#2 CANADA  
5 rows selected.
```

## Compatibility

Table 20-16 SQL standard compatibility

Feature ID	Description	Compatibility
F850	Top-level <order by clause> in <query expression>	O
F851	<order by clause> in subqueries	O
F852	Top-level <order by clause> in views	O
F855	Nested <order by clause> in <query expression>	O

## For More Information

Refer to [query expression](#).

## offset limit clause

### Function

It specifies the number of rows to skip and the number of rows to fetch from the query results.

### Syntax

```

<offset limit clause> ::=
    <result offset clause>
    | <fetch limit clause>
    | <result offset clause> <fetch limit clause>
<result offset clause> ::=
    OFFSET <offset row count> [ { ROW | ROWS } ]
<fetch limit clause> ::=
    <fetch first clause>
    | <limit clause>
<fetch first clause> ::=
    FETCH [ FIRST | NEXT ] [ <fetch row count> ] [ ROW ONLY | ROWS ONLY ]
<limit clause> ::=
    LIMIT { <fetch row count> | <offset row count> , <fetch row count> | ALL }

```

### Invocation and Access Rules

The access privilege for <offset limit clause> is not required.

### Syntax Rules and Parameters

#### <result offset clause>

- <offset row count> value should be a positive integer which is equal to or bigger than zero.
- ROW and ROWS are keywords with the same meaning and they can be omitted.
- If the statement is omitted, it means as same as *OFFSET 0 ROWS*.

#### <fetch limit clause>

- It specifies the number of rows to skip in the query result.
- If the statement is omitted, it means as same as *LIMIT ALL*.



## ⟨fetch first clause⟩

- It specifies the number of rows to fetch from the query result.
- It can not be used together with ⟨limit clause⟩.
- FIRST and NEXT are keywords with the same meaning and they can be omitted.
- ROW ONLY and ROWS ONLY are keywords with the same meaning and they can be omitted.
- ⟨fetch row count⟩
  - It should be a positive integer which is bigger than zero.
  - It can be omitted and if it is omitted, its value is one.

## ⟨limit clause⟩

- It specifies the number of rows to fetch.
- It can simultaneously specify both the number of rows to fetch and the number of rows to be skipped from query results .
- It can not be used together with ⟨fetch first clause⟩.
- When it is used as LIMIT ⟨fetch row count⟩
  - ⟨fetch row count⟩ should be a positive integer which is bigger than zero.
  - The statement means same as *FETCH FIRST ⟨fetch row count⟩ ROWS ONLY*.
- When it is used as LIMIT ⟨offset row count⟩, ⟨fetch row count⟩
  - It can not be used together with ⟨result offset clause⟩.
  - ⟨offset row count⟩ should be a positive integer which is equal to or bigger than zero.
  - ⟨fetch row count⟩ should be a positive integer which is bigger than zero.
  - The statement means same as *OFFSET ⟨offset row count⟩ ROWS FETCH FIRST ⟨fetch row count⟩ ROWS ONLY*.
- When it is used as LIMIT ALL
  - It does not limit the number of rows to fetch.

## Description

### ⟨result offset clause⟩

It fetches rows from the ⟨offset row count⟩th of the query results. If the result which ⟨offset row count⟩ queried is equal to or greater than the number of rows, the number of fetch rows is 0.

```
gSQL> SELECT c1 FROM t1;
C1
--
1
2
3
3 rows selected.
```

```

gSQL> SELECT c1 FROM t1 OFFSET 1;
C1
--
 2
 3
2 rows selected.
gSQL> SELECT c1 FROM t1 OFFSET 3;
no rows selected.

```

## ⟨fetch first clause⟩

It fetches the query results as many as the number of ⟨fetch row count⟩.

```

gSQL> SELECT c1 FROM t1;
C1
--
 1
 2
 3
3 rows selected.
gSQL> SELECT c1 FROM t1 FETCH FIRST 2 ROWS ONLY;
C1
--
 1
 2
2 rows selected.

```

## ⟨limit clause⟩

When LIMIT ⟨fetch\_row\_count⟩ is used, it fetches the query results as many as the number of ⟨fetch row count⟩.

When LIMIT ⟨offset row count⟩ is used, ⟨fetch row count⟩, it fetches the query results as many as the number of ⟨fetch row count⟩ from the ⟨offset row count⟩th row.

When LIMIT ALL is used, it returns the query results to a user without limit of the number.

```

gSQL> SELECT c1 FROM t1;
C1
--
 1
 2
 3

```

3 rows selected.

- LIMIT <fetch\_row\_count>

```
gSQL> SELECT c1 FROM t1 LIMIT 2;
```

C1

--

1

2

2 rows selected.

- LIMIT <offset row count>, <fetch\_row\_count>

```
gSQL> SELECT c1 FROM t1 LIMIT 1, 1;
```

C1

--

2

1 row selected.

- LIMIT ALL

```
gSQL> SELECT c1 FROM t1 LIMIT ALL;
```

C1

--

1

2

3

3 rows selected.

## Examples

The following is an example of SELECT statement which uses <result offset clause>.

```
gSQL> SELECT c_name, c_nation FROM customer OFFSET 1;
```

C\_NAME      C\_NATION

-----

Customer#2 CANADA

Customer#3 KOREA

Customer#4 GERMANY

Customer#5 UNITED STATES

4 rows selected.

The following is an example of SELECT statement which uses <fetch first clause>.

```
gSQL> SELECT c_name, c_nation FROM customer FETCH FIRST ROW ONLY;
```

C\_NAME      C\_NATION

-----

```

Customer#1 KOREA
1 row selected.
gSQL> SELECT c_name, c_nation FROM customer FETCH FIRST 2 ROW ONLY;
C_NAME      C_NATION
-----
Customer#1 KOREA
Customer#2 CANADA
2 rows selected.

```

The following is an example of SELECT statement which uses <limit clause>.

```

gSQL> SELECT c_name, c_nation FROM customer LIMIT 1;
C_NAME      C_NATION
-----
Customer#1 KOREA
1 row selected.
gSQL> SELECT c_name, c_nation FROM customer LIMIT 1, 2;
C_NAME      C_NATION
-----
Customer#2 CANADA
Customer#3 KOREA
2 rows selected.
gSQL> SELECT c_name, c_nation FROM customer LIMIT ALL;
C_NAME      C_NATION
-----
Customer#1 KOREA
Customer#2 CANADA
Customer#3 KOREA
Customer#4 GERMANY
Customer#5 UNITED STATES
5 rows selected.

```

The following is an example of SELECT statement which uses <result offset clause> and <fetch limit clause>

```

gSQL> SELECT c_name, c_nation FROM customer OFFSET 1 FETCH 2;
C_NAME      C_NATION
-----
Customer#2 CANADA
Customer#3 KOREA
2 rows selected.
gSQL> SELECT c_name, c_nation FROM customer OFFSET 1 LIMIT 2;

```

```

C_NAME      C_NATION
-----
Customer#2  CANADA
Customer#3  KOREA
2 rows selected.

```

## Compatibility

**Table 20-17** SQL standard compatibility

Feature ID	Description	Compatibility
F861	Top-level <result offset clause> in <query expression>	O
F862	<result offset clause> in subqueries	O
F863	Nested <result offset clause> in <query expression>	O
F864	Top-level <result offset clause> in views	O
F865	dynamic <offset row count> in <result offset clause>	X

## set operator

### Function

It performs a set operation for results of the subquery.

### Syntax

```

<set operator> ::=
    <set operator term>
  | <query expression body> UNION [ ALL | DISTINCT ] <set operator term>
  | <query expression body> EXCEPT [ ALL | DISTINCT ] <set operator term>
  | <query expression body> MINUS [ ALL | DISTINCT ] <set operator term>
<set operator term> ::=
    <query term>
  | <set operator term> INTERSECT [ ALL | DISTINCT ] <set operator term>

```

### Invocation and Access Rules

All access privileges for the <query expression> in each <set operator term> are required for using <set operator> statement.

### Syntax Rules and Parameters

#### <set operator>

- It specifies the set operations among the subqueries.
- The number of the target in <select list> of each subquery should be same, and all matched targets should belong to the same data type group.
- The representative name of the result target of <set operator> is the target name of <select list> of the first subquery.
  - gSQL> SELECT c1 AS NAME FROM t1 UNION SELECT i1 FROM t2;
 

```

NAME
----
1
2
2 rows selected.

```
- If the processing order is not explicitly specified by using parentheses it processes by evaluating specified subqueries from the left to the right.
- The meaning of each operator in <set operator> is as follows.

- UNION
  - UNION ALL: It is a union of all subquery results without removing the duplicates.
  - UNION DISTINCT: It is a union of all subquery results, which removed the duplicates.
  - If at least one of ALL and DISTINCT is not specified, it is operated as same as when DISTINCT is specified.
- EXCEPT
  - EXCEPT ALL: It returns the difference of all rows for the subquery result including all duplicates.
  - EXCEPT DISTINCT: It returns the difference of all rows for the subquery result excluding all duplicates.
  - If at least one of ALL and DISTINCT is not specified, it is operated as same as when DISTINCT is specified.
- MINUS
  - It is an alias of EXCEPT and, it is operated as same as EXCEPT.
- INTERSECT
  - INTERSECT ALL: It is a intersection of all subquery results without removing the duplicates.
  - INTERSECT DISTINCT: It is a intersection of all subquery results, which removed the duplicates.
  - If at least one of ALL and DISTINCT is not specified, it is operated as same as when DISTINCT is specified.

## ⟨query term⟩

It specifies the single subquery.

For more information, refer to **query expression**.

## Description

### The Differences between ALL and DISTINCT in ⟨set operator⟩

For example, if the data of the table R1 and R2 is given as follows, the result of each ⟨set operator⟩ is as follows.

- TABLE data
  - R1 TABLE = {1, 1, 1, 2, 2, 2, 3, 4, 4, 5}
  - R2 TABLE = {1, 1, 3, 3, 4}
- SELECT \* FROM R1 UNION ALL SELECT \* FROM R2;
  - result = {1, 1, 1, 1, 1, 2, 2, 2, 3, 3, 3, 4, 4, 4, 5}
- SELECT \* FROM R1 UNION DISTINCT SELECT \* FROM R2;
  - result = {1, 2, 3, 4, 5}
- SELECT \* FROM R1 MINUS ALL SELECT \* FROM R2;
  - result = {1, 2, 2, 2, 4, 5}
- SELECT \* FROM R1 MINUS DISTINCT SELECT \* FROM R2;

- result = {2, 5}
- SELECT \* FROM R1 INTERSECT ALL SELECT \* FROM R2;
  - result = {1, 1, 3, 4}
- SELECT \* FROM R1 INTERSECT DISTINCT SELECT \* FROM R2;
  - result = {1, 3, 4}

**Figure 1** SET operation results

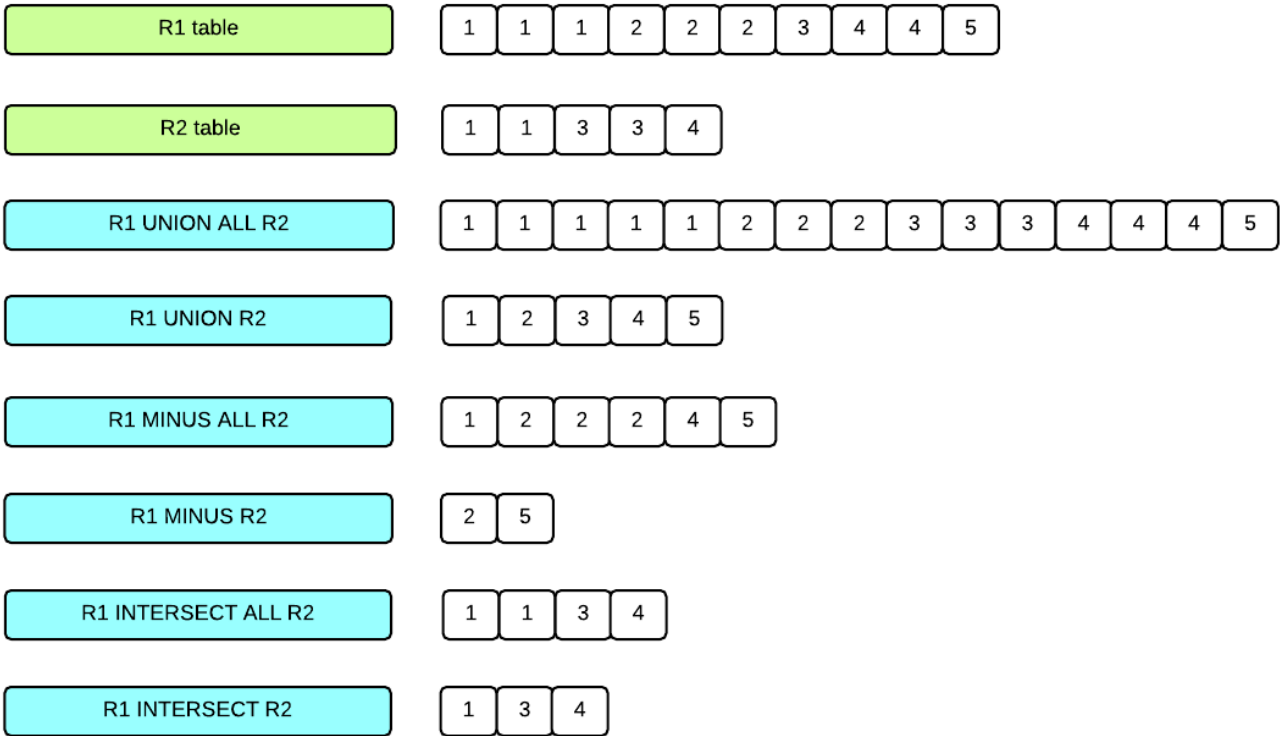

## Operator Precedence

The operator precedence of <set operator> is as follows.

- Parentheses ( ) has a priority.
- INTERSECT has a priority.
- For UNION and EXCEPT, the precedence is according to an order listed from left to right within an expression.

## Result Type of <set operator>

The i-th column of all subqueries in <set operator> should be a data type of the same family, and its result type is determined by **Result Type Combination Rule**.

However, LONG VARCHAR and LONG VARBINARY types can only use UNION ALL.



## ORDER BY Clause

When <set operator> is used together with ORDER BY, and the column names are different among subqueries, then it can be used as follows.

- ORDER BY indicator
  - It specifies the order of result columns.
 

```
SELECT c1 FROM t1
UNION ALL
SELECT c2 FROM t2
ORDER BY 1;
```
- ORDER BY left\_column\_name
  - It specifies the column name of the first subquery.
 

```
SELECT c1 FROM t1
UNION ALL
SELECT c2 FROM t2
ORDER BY c1;
```

## Examples

The following is an example of SELECT statement which uses UNION operator.

```
gSQL> SELECT s_nation nation FROM supplier UNION ALL SELECT c_nation FROM customer;
NATION
-----
FRANCE
KOREA
GERMANY
UNITED STATES
CANADA
KOREA
CANADA
KOREA
GERMANY
UNITED STATES
10 rows selected.
gSQL> SELECT s_nation nation FROM supplier UNION DISTINCT SELECT c_nation FROM customer;
NATION
-----
UNITED STATES
CANADA
KOREA
```

GERMANY

FRANCE

5 rows selected.

The following is an example of SELECT statement which uses EXCEPT operator.

```
gSQL> SELECT c_nation nation FROM customer EXCEPT ALL SELECT s_nation FROM supplier;
```

NATION

-----

KOREA

1 row selected.

```
gSQL> SELECT c_nation nation FROM customer EXCEPT DISTINCT SELECT s_nation FROM supplier;
```

no rows selected.

The following is an example of SELECT statement which uses INTERSECT operator.

```
gSQL> SELECT c_nation nation FROM customer INTERSECT ALL SELECT s_nation FROM supplier;
```

NATION

-----

UNITED STATES

CANADA

KOREA

GERMANY

4 rows selected.

```
gSQL> SELECT c_nation nation FROM customer INTERSECT DISTINCT SELECT s_nation FROM supplier;
```

NATION

-----

UNITED STATES

CANADA

KOREA

GERMANY

4 rows selected.

## Compatibility

**Table 20-18** SQL standard compatibility

Feature ID	Description	Compatibility
F302	INTERSECT table operator	O
F301	CORRESPONDING	X
T551	Optional key words for default syntax	O
F304	EXCEPT ALL table operator	O

## For More Information

Refer to `query expression`.

# subquery

## Function

It specifies the scalar value, row, table which are derived from `<query expression>`.

## Syntax

```
<scalar subquery> ::=  
    <subquery>  
<row subquery> ::=  
    <subquery>  
<table subquery> ::=  
    <subquery>  
<subquery> ::=  
    ( <query expression> )
```

## Invocation and Access Rules

The access privilege for `<query expression>` in `<subquery>` is required.

## Syntax Rules and Parameters

### `<scalar subquery>`

- The number of targets in `<query expression>` should be one.
- The result value according to the number of rows returned from `<query expression>` is as follows.
  - If the number of returned rows is zero, the result value is NULL.
  - If the number of returned rows is one, the result value is a value contained in the row.
  - If the number of returned rows is two or more, an exception error occurs.

### `<row subquery>`

- The number of target in `<query expression>` should be two or more.
- The result value according to the number of rows returned from `<query expression>` is as follows.
  - If the number of returned rows is zero, the result value is a row all of whose columns are NULL.
  - If the number of returned rows is one, the result value is that row.
  - If the number of returned rows is two or more, an exception error occurs.

## ⟨table subquery⟩

- The number of target in ⟨query expression⟩ should be one or more.
- The result according to the number of rows returned from ⟨query expression⟩ is as follows.
  - If the number of returned rows is zero, the result value is *no rows*.
  - If the number of returned rows is one or more, the result value is that row.

## Description

### ⟨scalar subquery⟩

⟨scalar subquery⟩ returns one row which has one column as a result. The target of ⟨scalar subquery⟩ should be only one, and the result data type depends on the data type of the target.

⟨scalar subquery⟩ can be used alone in the target of ⟨select list⟩, and it can be used in the operator which has a single column.

### ⟨row subquery⟩

⟨row subquery⟩ returns one row which has two or more columns as a result. The targets of ⟨row subquery⟩ should be two or more, and the result data type depends on the data type of each target.

⟨row subquery⟩ can not be used alone in the target of ⟨select list⟩, and it can only be used in the row operator which has two or more columns.

### ⟨table subquery⟩

⟨table subquery⟩ returns one or more rows which have one or more columns as a result. The targets of ⟨table subquery⟩ should be one or more, and the result data type depends on the data type of each target.

⟨table subquery⟩ can not be used alone in the target of ⟨select list⟩, but it can be used in the operators such as IN, NOT IN, EXISTS, NOT EXISTS, quantify operator.

## Examples

The following is an example of SELECT statement which uses ⟨scalar subquery⟩.

```
gSQL> SELECT (SELECT c_name FROM dual) FROM customer;
(SELECT C_NAME FROM DUAL)
-----
Customer#1
Customer#2
Customer#3
Customer#4
```

```

Customer#5
5 rows selected.
gSQL> SELECT c_name, c_nation FROM customer WHERE c_nation = (SELECT 'CANADA' FROM dual);
C_NAME      C_NATION
-----
Customer#2 CANADA
1 row selected.

```

The following is an example of SELECT statement which uses <row subquery>.

```

gSQL> SELECT p_name, p_brand, p_type FROM part WHERE (p_brand, p_type) = (SELECT 'Brand#1',
'NICKEL' FROM dual);
P_NAME P_BRAND  P_TYPE
-----
Part#2 Brand#1  NICKEL
1 row selected.

```

The following is an example of SELECT statement which uses <table subquery>.

```

gSQL> SELECT s_name, s_nation FROM supplier WHERE s_nation IN (SELECT c_nation FROM customer);
S_NAME      S_NATION
-----
Supplier#2   KOREA
Supplier#3   GERMANY
Supplier#4   UNITED STATES
Supplier#5   CANADA
4 rows selected.
gSQL> SELECT * FROM (SELECT s_name, s_nation FROM supplier);
S_NAME      S_NATION
-----
Supplier#1   FRANCE
Supplier#2   KOREA
Supplier#3   GERMANY
Supplier#4   UNITED STATES
Supplier#5   CANADA
5 rows selected.

```

## Compatibility

**Table 20-19** SQL standard compatibility

Feature ID	Description	Compatibility
F471	Scalar subquery values	O
F641	Row and table constructors	X
T501	Enhanced EXISTS predicate	O
E061-11	Subqueries in IN predicate	O
E061-12	Subqueries in quantified comparison predicate	O
E061-12	Correlated subqueries	O

## For More Information

Refer to the followings.

- **from clause**
- **where clause**

## hint clause

It specifies a hint to be used for a query execution.

For more information, refer to **SQL Hint**.



## 20.17 SELECT .. FOR UPDATE

### Function

It sets whether or not to update the result set of SELECT statement.

### Syntax

```

<select for update statement> ::=
    <query expression> <updatability clause>
    ;
<updatability clause> ::=
    FOR READ ONLY
    | FOR UPDATE [ OF <column name list> ] [ <lock wait mode> ]
<lock wait mode> ::=
    | WAIT
    | WAIT second
    | NOWAIT
  
```

### Invocation and Access Rules

The user should satisfy the following conditions to perform <select for update statement>.

- One of the following privileges for all tables used in the statement is required for a user to perform <query expression>.
  - SELECT(columns) ON TABLE for all columns used in the statement among the table columns
  - (SELECT or CONTROL TABLE) ON TABLE for that table
  - (SELECT TABLE or CONTROL SCHEMA) ON SCHEMA for the schema to which the table belongs
  - SELECT ANY TABLE ON DATABASE
- If FOR UPDATE clause is used, one of the following privileges for the tables to be locked is required.
  - (LOCK or CONTROL TABLE) ON TABLE for that table
  - (LOCK TABLE or CONTROL SCHEMA) ON SCHEMA for the schema to which the table belongs
  - LOCK ANY TABLE ON DATABASE

## Syntax Rules and Parameters

### <query expression>

INTO clause should not exist in SELECT statement.

To use FOR UPDATE, the query should identify the row updates of the base table, or it should be an updatable query which can acquire the lock into the row.

The updatable query should satisfy all of following conditions.

- DISTINCT should not exist in the top-level query.
  - (X) SELECT DISTINCT \* FROM t1;
- GROUP BY, HAVING, aggregation function should not exist in the top-level query.
  - (X) SELECT MAX(c1) FROM t1;
- Set operators should not exist.
  - (X) SELECT \* FROM t1 UNION ALL SELECT \* FROM t2;
- There should be at least one updatable column in the table listed in FROM clause.
  - The column of the table which is not for cross join among the tables included in join is not an updatable column.
    - OUTER JOIN is not the cross join.
    - NATURAL JOIN is not the cross join.
    - If USING clause is used in INNER JOIN, it is not the cross join.
  - The column of the following tables is not an updatable column.
    - Dictionary table, fixed table, performance view
  - The column of a view is not an updatable table.

For more information about SELECT statement, refer to **query expression**.

### <updatability clause>

It specifies whether or not to update the row for the result set.

- FOR READ ONLY
  - The read-only query is declared.
- FOR UPDATE
  - The writable query is declared.
  - x lock is acquired for the rows until the end of the transaction to prevent other transactions from updating the rows when executing the query.
  - <query expression> should be an updatable query.

## FOR UPDATE OF ...

It lists the columns relating to acquiring lock when executing the query.

- The column listed in FOR UPDATE OF statement.
  - It should be updatable columns of the table listed in the FROM clause of <query expression>.
  - It acquires a lock for the table of the listed column.
- Only FOR UPDATE is used
  - It means the same as listing all updatable columns of the table in FROM clause of <query expression>.
  - It acquires a lock for the table of all columns.

## <lock wait mode>

It is used together with FOR UPDATE statement, and it specifies the lock acquisition method.

- WAIT
  - It acquires a lock for all rows of the query result before obtaining the query result.
  - It waits until acquiring a lock.
- WAIT second
  - It acquires a lock for all rows of the query result before acquiring the query result.
  - If the lock is not acquired for a specified time, an error occurs.
  - The wait time is in seconds and it can use the value between 0 and 1,000,000,000.
- NOWAIT
  - It acquires a lock for all rows of the query result before acquiring the query result.
  - If the lock is not immediately acquired, an error occurs.
- If it is not specified, the default value is WAIT.

## Description

SELECT statement keep fetching the rows regardless of whether the transaction ends. However, SELECT .. FOR UPDATE statement can not fetch the rows when the transaction ends because the statement acquires the lock for the rows.



### Cursor holdability

- WITH HOLD
  - It can keep fetching regardless of whether the transaction ends.
  - It is also known as fetch across commit.

- WITHOUT HOLD
  - When the transaction ends, it can not fetch.

## Examples

The following is an example of acquiring a lock for the row by using FOR UPDATE statement.

```
gSQL> SELECT id, data FROM t1 WHERE id = 3 FOR UPDATE;
ID DATA
-- -----
 3 data_3
1 row selected.
```

The following uses join and ORDER BY clause but it is an updatable query, so FOR UPDATE statement can be used.

```
gSQL> SELECT t1.id, t1.name, t2.addr
        FROM t1, t2
        WHERE t1.id = t2.id
        ORDER BY 1
        FOR UPDATE;
ID NAME  ADDR
-- -----
 1 someone somewhere
 2 anyone  anywhere
 3 unknown N/A
 4 leekmo  leekmo's home
 5 mkkim   seoul
5 rows selected.
```

The following is a non-updatable query, so FOR UPDATE statement can not be used.

```
gSQL> SELECT id, COUNT(*)
        FROM t1
        GROUP BY id
        FOR UPDATE;
ERR-42000(16112): query expression is not updatable
```

## Compatibility

In the SQL standard, <select for update statement> is not defined, but it can be defined by using **DECLARE cursor\_name** statement.

## 20.18 SELECT .. INTO

### Function

It retrieves a single row by using a query, then obtains the value of retrieved row into the host variable.

### Syntax

```
<select statement: single row> ::=  
    SELECT [ <hint clause> ] [ <set quantifier> ] <select list>  
        INTO <select target list>  
        <table expression>  
    ;  
<select target list> ::=  
    variable_name [, ...]
```

### Invocation and Access Rules

One of the following privileges for all tables used in the statement is required for a user to perform <select statement: single row>.

- SELECT(columns) ON TABLE for all columns used in the statement among the table columns
- (SELECT or CONTROL TABLE) ON TABLE for that table
- (SELECT TABLE or CONTROL SCHEMA) ON SCHEMA for the schema to which the table belongs
- SELECT ANY TABLE ON DATABASE

### Syntax Rules and Parameters

#### <hint clause>

It specifies hints for query execution.

For more information, refer to **hint clause** of SELECT statement.

## <set quantifier>

It specifies whether to remove duplicates from the query result.  
For more information, refer to **query specification** clause.

## <select list>

It specifies the columns to be retrieved from the query result.  
For more information, refer to **select list** clause.

## INTO <select target list>

The number of the variable specified in INTO clause should be equal to the number of the expression specified in <select list>.

## <table expression>

It specifies the query information such as a search condition.  
For more information, refer to **query specification** clause.

## Description

The rows to be retrieved should be one or less.  
If two or more rows are retrieved, an error occurs.

## Differences among SELECT-related Statements

- <select statement>
  - It retrieves multiple rows which satisfy the condition, and the retrieved rows can be retrieved by using API such as SQLFetch ().
  - e.g. SELECT c1 FROM t1 WHERE c1 > 0;
- <select statement: single row>
  - It can retrieve one or less row which satisfies the condition, then obtains the value into the host variable in INTO clause when the retrieved row is a single row.
  - e.g. SELECT c2 INTO :v1 FROM t1 WHERE c1 = 0;

## Example

The following is an example of obtaining the value into the host variable by using interactive SQL (gsql).

```
gSQL> \var v_id INTEGER
gSQL> \var v_data VARCHAR(128)
gSQL> SELECT id, data INTO :v_id, :v_data FROM t1 WHERE id = 3;
V_ID V_DATA
---- -
      3 data_3
1 row selected.
```



## 20.19 SELECT .. INTO .. FOR UPDATE

### Function

It sets whether to update the row by retrieving a single row through the query, then obtains the value of retrieved row into the host variable.

### Syntax

```

<select for update statement: single row> ::=
    SELECT [ <hint clause> ] [ <set quantifier> ] <select list>
        INTO <select target list>
            <table expression> <updatability clause>
    ;
<select target list> ::=
    variable_name [, ...]
<updatability clause> ::=
    FOR READ ONLY
    | FOR UPDATE [ OF <column name list> ] [ <lock wait mode> ]
<lock wait mode> ::=
    | WAIT
    | WAIT second
    | NOWAIT

```

### Invocation and Access Rules

One of the following privileges for all tables used in the statement is required for a user to perform <select statement: single row>.

- SELECT(columns) ON TABLE for all columns used in the statement among the table columns
- (SELECT or CONTROL TABLE) ON TABLE for that table
- (SELECT TABLE or CONTROL SCHEMA) ON SCHEMA for the schema to which the table belongs
- SELECT ANY TABLE ON DATABASE

If FOR UPDATE clause is used, one of the following privileges for the tables to be locked is required.

- (LOCK or CONTROL TABLE) ON TABLE for that table
- (LOCK TABLE or CONTROL SCHEMA) ON SCHEMA for the schema to which the table belongs
- LOCK ANY TABLE ON DATABASE

## Syntax Rules and Parameters

### ⟨select for update statement: single row⟩

To use FOR UPDATE, the query should identify the row updates of the base table, or it should be an updatable query which can acquire the lock into the row.

The updatable query should satisfy all of following conditions.

- DISTINCT should not exist in the top-level query.
  - (X) SELECT DISTINCT \* FROM t1;
- GROUP BY, HAVING, aggregation function should not exist in the top-level query.
  - (X) SELECT MAX(c1) FROM t1;
- Set operators should not exist.
  - (X) SELECT \* FROM t1 UNION ALL SELECT \* FROM t2;
- There should be at least one updatable column in the table listed in FROM clause.
  - The column of the table which is not for cross join among the tables included in join is not an updatable column.
    - FULL OUTER JOIN is not the cross join.
    - NATURAL JOIN is not the cross join.
    - If USING clause is used in INNER JOIN, it is not the cross join.
  - The column of the following tables is not an updatable column.
    - Dictionary table, fixed table, performance view
  - The column of a view is not an updatable table.

### ⟨updatability clause⟩

It specifies whether or not to update the row for the result set.

- FOR READ ONLY
  - The read-only query is declared.
- FOR UPDATE
  - The writable query is declared.
  - x lock is acquired for the rows until the end of the transaction to prevent other transactions from updating the rows when executing the query.
  - ⟨query expression⟩ should be an updatable query.

## FOR UPDATE OF ...

It lists the columns relating to acquiring lock when executing the query.

- The column listed in FOR UPDATE OF statement.
  - It should be updatable columns of the table listed in the FROM clause of <query expression>.
  - It acquires a lock for the table of the listed column.
- Only FOR UPDATE is used
  - It means the same as listing all updatable columns of the table in FROM clause of <query expression>.
  - It acquires a lock for the table of all columns.

## <lock wait mode>

It is used together with FOR UPDATE statement, and it specifies the lock acquisition method.

- WAIT
  - It acquires a lock for all rows of the query result before obtaining the query result.
  - It waits until acquiring a lock.
- WAIT second
  - It acquires a lock for all rows of the query result before acquiring the query result.
  - If the lock is not acquired for a specified time, an error occurs.
  - The wait time is in seconds and it can use the value between 0 and 1,000,000,000.
- NOWAIT
  - It acquires a lock for all rows of the query result before acquiring the query result.
  - If the lock is not immediately acquired, an error occurs.
- If it is not specified, the default value is WAIT.

## <hint clause>

It specifies hints for query execution.

For more information, refer to **hint clause** of SELECT statement.

## <set quantifier>

It specifies whether to remove duplicates from the query result.

For more information, refer to **query specification** clause.

## ⟨select list⟩

It specifies the columns to be retrieved from the query result.  
For more information, refer to **select list** clause.

## INTO ⟨select target list⟩

The number of the variable specified in INTO clause should be equal to the number of the expression specified in ⟨select list⟩.

## ⟨table expression⟩

It specifies the query information such as a search condition.  
For more information, refer to **query specification** clause.

## Description

The rows to be retrieved should be one or less.  
If two or more rows are retrieved, an error occurs.

SELECT statement keep fetching the rows regardless of whether the transaction ends. However, SELECT .. FOR UPDATE statement can not fetch the rows when the transaction ends because the statement acquires the lock for the rows.



### Cursor holdability

- WITH HOLD
  - It can keep fetching regardless of whether the transaction ends.
  - It is also known as fetch across commit.
- WITHOUT HOLD
  - When the transaction ends, it can not fetch.

## Differences among SELECT-related Statements

- <select for update statement>
  - It retrieves multiple rows which satisfy the condition, sets whether to update them and the retrieved rows can be retrieved by using API such as SQLFetch ().
  - e.g. SELECT c1 FROM t1 WHERE c1 > 0 FOR UPDATE;
- <select for update statement: single row>
  - It can retrieve one or less row which satisfies the condition, sets whether to update them then obtains the value into the host variable in INTO clause when the retrieved row is a single row.
  - e.g. SELECT c2 INTO :v1 FROM t1 WHERE c1 = 0 FOR UPDATE;

## Examples

The following is an example of acquiring a lock for the row by using FOR UPDATE statement, and obtaining the value into the host variable by using interactive SQL (gsq).

```
gsq> \var v_id    INTEGER
gsq> \var v_data VARCHAR(128)
gsq> SELECT id, data INTO :v_id, :v_data FROM t1 WHERE id = 3 FOR UPDATE;
V_ID V_DATA
---- -
      3 data_3
1 row selected.
```

The following uses join and ORDER BY clause but it is an updatable query, so FOR UPDATE statement can be used.

```
gsq> \var v_id    INTEGER
gsq> \var v_name  VARCHAR(128)
gsq> \var v_addr  VARCHAR(128)
gsq> SELECT t1.id, t1.name, t2.addr
        INTO :v_id, :v_name, :v_addr
        FROM t1, t2
        WHERE t1.id = t2.id
        ORDER BY 1
        LIMIT 1
        FOR UPDATE;
ID NAME    ADDR
-----
1 someone somewhere
```

1 row selected.

The following is a non-updatable query, so FOR UPDATE statement can not be used.

```
gSQL> \var v_id    INTEGER
gSQL> \var v_count INTEGER
gSQL> SELECT id, COUNT(*)
        INTO :v_id, :v_count
        FROM t1
        GROUP BY id
        FOR UPDATE;
ERR-42000(16112): query expression is not updatable
```

## For More Information

Refer to the followings.

- [SELECT .. FOR UPDATE](#)
- [SELECT .. INTO](#)

## 20.20 SET CONSTRAINTS

### Function

It sets the check point of deferrable constraint in a transaction to IMMEDIATE or DEFERRED.

### Syntax

```
<set constraints mode statement> ::=  
    SET { CONSTRAINT | CONSTRAINTS } <constraint name list> { DEFERRED | IMMEDIATE }  
    ;  
<constraint name list> ::=  
    ALL  
    | <constraint name> [, ...]
```

### Invocation and Access Rules

Any separate access privilege is not required for a user to perform SET CONSTRAINTS.



It is not supported in the cluster system.

### Syntax Rules and Parameters

#### CONSTRAINT | CONSTRAINTS

CONSTRAINT and CONSTRAINTS are the keywords of the same meaning, and the SQL standard uses CONSTRAINTS.

#### <constraint name list>

It specifies the list of constraint names, or specifies ALL to set all deferrable constraints. When specifying <constraint name>, it should be the name of the deferrable constraint.

ALL means all deferrable constraints.

## DEFERRED | IMMEDIATE

It sets the check point of specified deferrable constraints.

- IMMEDIATE
  - It checks the specified constraints when executing the DML statement.
  - If the transaction violates the constraints, then an error occurs.
- DEFERRED
  - It checks the specified constraints when the transaction is committed.

If the transaction is in progress, the check point of the constraint is set in the current transaction. If the transaction is not in progress, it is set in the next transaction.

After the transaction ends, it does not affect the next transaction.

## Description

### Deferrable Constraint

DEFERRABLE constraint can change its check point.

The following is an example of creating a table with a deferrable constraint, and inserting data to the table.

```
gSQL> CREATE TABLE t1
(
  id INTEGER,
  name VARCHAR(128) CONSTRAINT t1_uk UNIQUE
      DEFERRABLE INITIALLY IMMEDIATE
);
Table created.
gSQL> COMMIT;
Commit complete.
gSQL> INSERT INTO t1 VALUES ( 1, 'leekmo' );
1 row created.
gSQL> INSERT INTO t1 VALUES ( 2, 'mkkim' );
1 row created.
gSQL> COMMIT;
Commit complete.
```



In the example above, UNIQUE constraint which is deferrable is created on a name column, and the initial check point is set as INITIALLY IMMEDIATE. Therefore, the constraint is checked whenever DML statement is executed.

In this case, if the user tries to exchange the name value of two rows as follows, it violates the constraint because the check point is IMMEDIATE.

```
gSQL> UPDATE t1 SET name = 'mkkim' WHERE id = 1;
ERR-23000(16057): unique constraint (PUBLIC.T1_UK) violated
gSQL> UPDATE t1 SET name = 'leekmo' WHERE id = 2;
ERR-23000(16057): unique constraint (PUBLIC.T1_UK) violated
```

If the check point is changed to DEFERRED as follows, the operation as same as above succeeds because the constraint is checked when the transaction is committed.

```
gSQL> SET CONSTRAINTS t1_uk DEFERRED;
Constraints set.
gSQL> UPDATE t1 SET name = 'mkkim' WHERE id = 1;
1 row updated.
gSQL> UPDATE t1 SET name = 'leekmo' WHERE id = 2;
1 row updated.
gSQL> COMMIT;
Commit complete.
```

If the check point is set to DEFERRED, then the constraint is checked when the transaction is committed. Therefore, if the transaction is committed when the constraint is violated, then the transaction fails and it is rolled back as follows.

```
gSQL> SET CONSTRAINTS t1_uk DEFERRED;
Constraints set.
gSQL> INSERT INTO t1 VALUES ( 3, 'leekmo' );
1 row created.
gSQL> COMMIT;
ERR-40002(16291): transaction rollback: integrity constraint violation : PUBLIC.T1_UK(1)
```

## Violation of a Deferred Constraint

Executing the following statements when the transaction violates the constraints set to DEFERRED, then an error occurs as follows.

- COMMIT
  - An error occurs and the transaction is rolled back.

- SET CONSTRAINTS ALL IMMEDIATE
  - An syntax error occurs.
- DDL
  - An syntax error occurs.

An unexpected ROLLBACK can occur when COMMIT, it is necessary to ensure whether the transaction violates the constraint by using SET CONSTRAINTS ALL IMMEDIATE statement.

```
gSQL> SET CONSTRAINTS t1_uk DEFERRED;
Constraints set.
gSQL> INSERT INTO t1 VALUES ( 3, 'leekmo' );
1 row created.
gSQL> SET CONSTRAINTS ALL IMMEDIATE;
ERR-23000(16038): integrity constraint violation : PUBLIC.T1_UK(1)
gSQL> SELECT * FROM t1 ORDER BY id;
ID NAME
-- -----
1 mkkim
2 leekmo
3 leekmo
3 rows selected.
gSQL> UPDATE t1 SET name = 'xcom73' WHERE id = 3;
1 row updated.
gSQL> SET CONSTRAINTS ALL IMMEDIATE;
Constraints set.
gSQL> COMMIT;
Commit complete.
```

## Transaction Control Language

SET CONSTRAINTS statement is a transaction control language which is used when the transaction is in progress such as **SAVEPOINT savepoint\_specifier**.

The transaction control such as COMMIT, ROLLBACK, ROLLBACK TO SAVEPOINT statement is applied to SET CONSTRAINTS statement.

The following is an example of a table with multiple deferrable constraints.

```
CREATE TABLE t1
(
  id1 INTEGER CONSTRAINT t1_uk1 UNIQUE DEFERRABLE INITIALLY IMMEDIATE,
  id2 INTEGER CONSTRAINT t1_uk2 UNIQUE DEFERRABLE INITIALLY IMMEDIATE,
```

```
id3 INTEGER CONSTRAINT t1_uk3 UNIQUE DEFERRABLE INITIALLY IMMEDIATE  
);
```

If <set constraints mode statement> statement is performed when the transaction is in progress, the check point of deferrable constraints is changed depending on each point as follows.

- result: success

```
INSERT INTO t1 VALUES ( 1, 1, 1 );  
1 row created.  
COMMIT;  
Commit complete.
```

- result: success

```
SAVEPOINT sp1;  
Savepoint created.
```

- result: success
- t1\_uk1 constraint is DEFERRED

```
SET CONSTRAINTS t1_uk1 DEFERRED;  
Constraints set.
```

- result: success

```
SAVEPOINT sp2;  
Savepoint created.
```

- result: success
- t1\_uk1, t1\_uk2 constraints are DEFERRED

```
SET CONSTRAINTS t1_uk2 DEFERRED;  
Constraints set.
```

- result: success

```
SAVEPOINT sp3;  
Savepoint created.
```

- result: success
- ALL constraints are DEFERRED

```
SET CONSTRAINTS ALL DEFERRED;  
Constraints set.
```

- result: success

```
SAVEPOINT sp4;  
Savepoint created.
```

- result: success
- ALL constraints are IMMEDIATE

```
SET CONSTRAINTS ALL IMMEDIATE;  
Constraints set.
```

When the transaction is partially rolled back by using ROLLBACK TO SAVEPOINT statement as follows, SET CONSTRAINTS statement is also partially rolled back and the check point is changed.

- result: error

```
INSERT INTO t1 VALUES ( 1, 2, 2 );  
ERR-23000(16057): unique constraint (PUBLIC.T1_UK1) violated
```

- result: error

```
INSERT INTO t1 VALUES ( 3, 1, 3 );  
ERR-23000(16057): unique constraint (PUBLIC.T1_UK2) violated
```

- result: error

```
INSERT INTO t1 VALUES ( 4, 4, 1 );  
ERR-23000(16057): unique constraint (PUBLIC.T1_UK3) violated
```

- result: success
- t1\_uk1, t1\_uk2 constraints are DEFERRED

```
ROLLBACK TO SAVEPOINT sp4;  
Rollback complete.
```

- result: success

```
INSERT INTO t1 VALUES ( 1, 2, 2 );  
1 row created.
```

- result: success

```
INSERT INTO t1 VALUES ( 3, 1, 3 );  
1 row created.
```

- result: success

```
INSERT INTO t1 VALUES ( 4, 4, 1 );  
1 row created.
```

- result: success
- t1\_uk1, t1\_uk2 constraints are DEFERRED

```
ROLLBACK TO SAVEPOINT sp3;  
Rollback complete.
```

- result: success

```
INSERT INTO t1 VALUES ( 1, 2, 2 );  
1 row created.
```

- result: success

```
INSERT INTO t1 VALUES ( 3, 1, 3 );  
1 row created.
```

- result: success

```
INSERT INTO t1 VALUES ( 4, 4, 1 );  
ERR-23000(16057): unique constraint (PUBLIC.T1_UK3) violated
```

- result: success
- t1\_uk1 constraint is DEFERRED

```
ROLLBACK TO SAVEPOINT sp2;  
Rollback complete.
```

- result: success

```
INSERT INTO t1 VALUES ( 1, 2, 2 );  
1 row created.
```

- result: error

```
INSERT INTO t1 VALUES ( 3, 1, 3 );
ERR-23000(16057): unique constraint (PUBLIC.T1_UK2) violated
```

- result: error

```
INSERT INTO t1 VALUES ( 4, 4, 1 );
ERR-23000(16057): unique constraint (PUBLIC.T1_UK3) violated
```

- result: success
- all constraint are IMMEDIATE

```
ROLLBACK TO SAVEPOINT sp1;
Rollback complete.
```

- result: error

```
INSERT INTO t1 VALUES ( 1, 2, 2 );
ERR-23000(16057): unique constraint (PUBLIC.T1_UK1) violated
```

- result: error

```
INSERT INTO t1 VALUES ( 3, 1, 3 );
ERR-23000(16057): unique constraint (PUBLIC.T1_UK2) violated
```

- result: error

```
INSERT INTO t1 VALUES ( 4, 4, 1 );
ERR-23000(16057): unique constraint (PUBLIC.T1_UK3) violated
```

- result: 1 row
- 1 1 1

```
SELECT * FROM t1;
ID1 ID2 ID3
----
1 1 1
1 row selected.
```

When the transaction is committed or rolled back, the effects of SET CONSTRAINTS statement is also terminated, and all deferrable constraints follows the constraints property which is INITIALLY IMMEDIATE or INITIALLY DEFERRED value.

## Examples

The following is an example of changing the check point by specifying the constraint name.

```
gSQL> SET CONSTRAINTS t1_uk1 DEFERRED;
Constraints set.
```

The following is an example of changing the check point of all deferrable constraints.

```
gSQL> SET CONSTRAINTS ALL DEFERRED;
Constraints set.
```

## Compatibility

The SQL standard does not define CONSTRAINT keyword clause.

**Table 20-20** SQL standard compatibility

Feature ID	Description	Compatibility
F721	Deferrable constraints	O

## For More Information

Refer to the followings.

- Adding constraints
  - CREATE TABLE
  - ALTER TABLE name ADD CONSTRAINT
  - ALTER TABLE name ADD COLUMN
  - ALTER TABLE name ALTER COLUMN
- Altering constraints: ALTER TABLE name ALTER CONSTRAINT
- Controlling the check point of constraints: SET CONSTRAINTS

## 20.21 SET SCHEMA schema\_name

### Function

It sets the default schema name to be used in the current session.

### Syntax

```
<set schema statement> ::=  
    SET SCHEMA schema_name  
    ;
```

### Invocation and Access Rules

N/A

### Syntax Rules and Parameters

#### schema\_name

It is the default schema name to be set in the current session.

### Description

It sets the default schema name to be used in the current session.

If the schema name of the object is not specified, then it becomes the default schema name to be used in the current session.

- When accessing as the user u1, then retrieve R relation by using the schema path of user u1.

```
% gsql u1 u1  
gsql> SELECT * FROM r;
```



- When SET SCHEMA statement is set, then then retrieve R relation by using NEW\_SCHEMA.R.

```
gsql> SET SCHEMA new_schema;
gsql> SELECT * FROM r;
```

## Examples

The following is an example of when user u1 has schema s1 and s2.

```
CREATE USER u1 IDENTIFIED BY u1 WITHOUT SCHEMA;
CREATE SCHEMA s1 AUTHORIZATION u1;
CREATE SCHEMA s2 AUTHORIZATION u1;
COMMIT;
ALTER USER u1 SCHEMA PATH ( s1, s2 );
GRANT ALL PRIVILEGES TO u1;
COMMIT;
CREATE TABLE s1.t1 ( c1 VARCHAR(32) );
INSERT INTO s1.t1 VALUES ( 'S1.T1' );
COMMIT;
CREATE TABLE s2.t1 ( c1 VARCHAR(32) );
INSERT INTO s2.t1 VALUES ( 'S2.T1' );
COMMIT;
```

It retrieves table S1.T1 by interpreting table t1 using schema path of user u1 when accessing for the first time.

```
% gsql u1 u1
gSQL> SELECT current_schema FROM dual;
CURRENT_SCHEMA
-----
S1
1 row selected.
gSQL> SELECT * FROM t1;
C1
-----
S1.T1
1 row selected.
```

It retrieves table S2.T1 by interpreting table t1 using schema name of the session after SET SCHEMA statement is used.

```
gSQL> SET SCHEMA s2;
Session set.
gSQL> SELECT current_schema FROM dual;
CURRENT_SCHEMA
-----
S2
1 row selected.
gSQL> SELECT * FROM t1;
C1
-----
S2.T1
1 row selected.
```

## Compatibility

Table 20-21 SQL standard compatibility

Feature ID	Description	Compatibility
F761	Session management	O

## 20.22 SET SESSION AUTHORIZATION user\_identifier

### Function

It sets the session user and current user.

### Syntax

```
<set session user identifier statement> ::=  
    SET SESSION AUTHORIZATION user_identifier  
    ;
```

### Invocation and Access Rules

ACCESS CONTROL ON DATABASE privilege is required for a logon user to perform <set session user identifier statement>.

The user information is managed in three types as follows.

- Logon user
  - It is a user who performed login, and it is maintained until the connection is closed.
- Session user
  - It is as same as the first logon user, but it can be changed using the SET SESSION AUTHORIZATION statement.
- Current user
  - It is generally as same as the session user, but it is temporarily changed internally in system to control access when using the PSM or view.
  - The session user and current user is similar to the difference between the unix system's real user and the effective user.

## Syntax Rules and Parameters

### user\_identifier

It is the username to be altered.

### Description

After performing SET SESSION AUTHORIZATION statement, all statements is performed based on the session user. Therefore, the privilege for the session user is checked and the owner of when creating objects also is the session user.

### Example

The following is an example that the user test with ACCESS CONTROL ON DATABASE privilege sets the user u1 to the session user.

```
gSQL> SET SESSION AUTHORIZATION u1;
Session set.
gSQL> SELECT LOGON_USER(), SESSION_USER(), CURRENT_USER FROM dual;
LOGON_USER() SESSION_USER() CURRENT_USER
-----
TEST          U1              U1
1 row selected.
```

### Compatibility

Table 20-22 SQL standard compatibility

Feature ID	Description	Compatibility
F321	User authorization	O

## 20.23 SET SESSION CHARACTERISTICS AS transaction\_mode

### Function

It sets the transaction property of a session.

### Syntax

```
<set session characteristics statement> ::=  
    SET SESSION CHARACTERISTICS AS TRANSACTION <transaction_mode>  
    ;  
<transaction_mode> ::=  
    { <transaction_access_mode> | ISOLATION LEVEL < isolation_level > }  
<transaction_access_mode> ::=  
    READ { ONLY | WRITE }  
< isolation_level > ::=  
    { READ COMMITTED | SERIALIZABLE }
```

### Syntax Rules and Parameters

#### <transaction\_access\_mode>

It is ACCESS MODE of the following transactions.

- READ ONLY
- READ WRITE

#### <isolation\_level>

It is ISOLATION LEVEL of the following transactions.

- READ COMMITTED
- SERIALIZABLE

## Description

SET SESSION CHARACTERISTICS sets the transaction property of a session. In other words, properties of all transactions created within the session follows these properties.

However, SET TRANSACTION `transaction_mode` statement sets only the property of a single transaction which is performed next.

## Examples

The following is an example that all transactions to be created within the session are set to READ ONLY.

```
gSQL> SET SESSION CHARACTERISTICS AS TRANSACTION READ ONLY;
Session set.
```

The following is an example that the isolation level of all transactions to be created within the session is set to READ COMMITTED.

```
gSQL> SET SESSION CHARACTERISTICS AS TRANSACTION ISOLATION LEVEL READ COMMITTED;
Session set.
```

## Compatibility

Table 20-23 SQL standard compatibility

Feature ID	Description	Compatibility
F761	Session management	O

## For More Information

Refer to SET TRANSACTION `transaction_mode`.

## 20.24 SET TIME ZONE

### Function

It sets the TIMEZONE of a session.

### Syntax

```
<set local time zone statement> ::=  
    SET TIME ZONE <set time zone value>  
    ;  
<set time zone value> ::=  
    { '[+|-]hh:mm' | LOCAL }
```

### Syntax Rules and Parameters

#### <set time zone value>

It is the TIMEZONE value to be set.

- hh:mm: It is a GMT OFFSET of the TIMEZONE to be set.
  - The range of the offset value is '-14:00' ~ '+14:00' .
- LOCAL: It is the TIME ZONE at the time of session creation.
  - TIME ZONE at the time of session creation is set to TIME ZONE of the client OS.

### Description

Altering the time zone of the session affects the result value of function such as **CURRENT\_TIME**, **CURRENT\_TIMESTAMP**.

## Example

The following is an example of altering the session time zone to '+09:00'.

```
gSQL> SET TIME ZONE '+09:00';  
Session set.
```

## Compatibility

Table 20-24 SQL standard compatibility

Feature ID	Description	Compatibility
F411	Time zone specifications	O



## 20.25 SET TRANSACTION transaction\_mode

### Function

It sets the transaction property.

### Syntax

```
<set transaction statement> ::=  
    SET TRANSACTION <transaction_mode>  
    ;  
<transaction_mode> ::=  
    { <transaction_access_mode> | ISOLATION LEVEL < isolation_level > }  
<transaction_access_mode> ::=  
    READ { ONLY | WRITE }  
< isolation_level > ::=  
    { READ COMMITTED | SERIALIZABLE }
```

### Syntax Rules and Parameters

#### <transaction\_access\_mode>

It is ACCESS MODE of the following transactions.

- READ ONLY
- READ WRITE

#### <isolation\_level>

It is ISOLATION LEVEL of the following transactions.

- READ COMMITTED
- SERIALIZABLE

## Description

SET TRANSACTION sets property of the next transaction, and the property is reset to the default value after the next transaction ends.

## Example

The following is an example of setting the next transaction to READ ONLY.

```
gSQL> SET TRANSACTION READ ONLY;  
Transaction set.
```

## Compatibility

Table 20-25 SQL standard compatibility

Feature ID	Description	Compatibility
T251	SET TRANSACTION statement: LOCAL option	X

## For More Information

Refer to SET SESSION CHARACTERISTICS AS transaction\_mode.

## 20.26 TRUNCATE TABLE

### Function

It truncates all rows from a table.

### Syntax

```
<truncate table statement> ::=  
    TRUNCATE TABLE table_name  
        [ RESTART IDENTITY | CONTINUE IDENTITY ]  
        [ DROP STORAGE | DROP ALL STORAGE ]  
    ;
```

### Invocation and Access Rules

One of the following privileges is required for a user to perform <truncate table statement>.

- The owner of that table
- CONTROL TABLE ON TABLE for the table
- (DROP TABLE or CONTROL SCHEMA) ON SCHEMA for the schema to which the table belongs
- DROP ANY TABLE ON DATABASE

### Syntax Rules and Parameters

#### table\_name

It is the name of a target table whose rows are to be truncated.

It can define schema to which the table belongs such as schema\_name.table\_name and if schema\_name is omitted, the default schema name of the user performing the statement is used.

## [ RESTART IDENTITY | CONTINUE IDENTITY ]

- RESTART IDENTITY
  - If an identity column which has auto created value in that table exists, it automatically restarts value.
- CONTINUE IDENTITY
  - If an identity column which has auto created value in that table exists, it does not change the existing value.
- If it is not specified, the default value is CONTINUE IDENTITY.

## [ DROP STORAGE | DROP ALL STORAGE ]

- DROP STORAGE
  - It drops allocated extents from the the table excluding the space of MINSIZE.
- DROP ALL STORAGE
  - It drops all extents allocated to the table.
- If it is not specified, the default value is DROP STORAGE.

## Description

Data Definition Language (DDL) statement such as TRUNCATE TABLE can be rolled back if it is before when the transaction is committed.

## Examples

The following is an example of performing TRUNCATE TABLE statement.

```
gSQL> TRUNCATE TABLE t1;  
Table truncated.
```

The following is an example of restarting the value of the identity column when performing TRUNCATE TABLE.

```
TRUNCATE TABLE t1 RESTART IDENTITY;  
Table truncated.
```

# Compatibility

The SQL standard does not define [ DROP STORAGE | DROP ALL STORAGE ] clause.

**Table 20-26** SQL standard compatibility

Feature ID	Description	Compatibility
F200	TRUNCATE TABLE statement	O
F202	TRUNCATE TABLE: identity column restart option	O

## 20.27 UPDATE

### Function

It updates rows in a table.

### Syntax

```

<update statement: searched> ::=
    UPDATE table_name [ [ AS ] alias_name ]
        SET <set clause> [, ...]
        [ WHERE <search condition> ]
        [ <result offset clause> ]
        [ <fetch limit clause> ]
    ;
<set clause> ::=
    column_name = { <value expression> | DEFAULT }
    | ( column_name [, ...] ) = ( { <value expression> | DEFAULT } [, ...] )
    | ( column_name [, ...] ) = ( <query expression> )
<result offset clause> ::=
    OFFSET skip_count [ ROW | ROWS ]
<fetch limit clause> ::=
    <fetch first clause>
    | <limit clause>
<fetch first clause> ::=
    FETCH [ FIRST | NEXT ] [ row_count ] [ ROW ONLY | ROWS ONLY ]
<limit clause>
    LIMIT { fetch_row_count | offset_row_count, fetch_row_count | ALL }

```

### Invocation and Access Rules

One of the following privileges is required for a user to perform <update statement: searched>.

- UPDATE(columns) ON TABLE for all columns which are targets to be updated
- (UPDATE or CONTROL TABLE) ON TABLE for the table

- (UPDATE TABLE or CONTROL SCHEMA) ON SCHEMA for the schema to which the table belongs
- UPDATE ANY TABLE ON DATABASE

## Syntax Rules and Parameters

### table\_name

It is the name of a target table whose rows are to be updated.

It can define schema to which the table belongs such as schema\_name.table\_name and if schema\_name is omitted, the default schema name of the user performing the statement is used.

### [ AS alias\_name ]

It is the alias of table\_name.

### <set clause>

It defines the columns to be updated and its values to be assigned. The number of columns in <set clause > should be as same as the number of values.

It can be defined as follows.

- column\_name = { <value expression> | DEFAULT }

```
UPDATE table_name
  SET column1 = value1, column2 = value2, column3 = value3
```

- ( column\_name [, ...] ) = ( { <value expression> | DEFAULT } [, ...] )

```
UPDATE table_name
  SET ( column1, column2, column3 ) = ( value1, value2, value3 )
```

- ( column\_name [, ...] ) = ( <query expression> )

```
UPDATE table_name
  SET column1 = ( SELECT max(value1) FROM other_table_name )
```

<query expression> should be a query which creates a single row.

If DEFAULT is defined as a column value, the default values (refer to **<default clause>**) defined when executing CREATE TABLE is used. If it is not defined, NULL value is assigned.

## WHERE **<search condition>**

It updates the rows which satisfy WHERE condition.

If WHERE condition is not specified, all rows are updated.

For more information about WHERE condition, refer to **where clause** of SELECT.

## **<result offset clause>**

It specifies the number of rows to skip from the query result.

For more information, refer to **<result offset clause>** of SELECT.

## **<fetch limit clause>**

It specifies the number of rows to fetch in two ways, which are **<fetch first clause>** and **<limit clause>**.

- **<fetch first clause>**
  - It specifies the number of rows to be fetched.
  - For more information, refer to **<fetch first clause>** of SELECT statement.
- **<limit clause>**
  - It specifies the number of rows to be fetched, or it simultaneously specifies both the number of rows to be skipped and the number of rows to be fetched.
  - For more information, refer to **<limit clause>** of SELECT statement.

## Description

### Differences among UPDATE-related Statements

- **UPDATE**
  - It updates multiple rows which satisfy the condition.
  - e.g. UPDATE t1 SET c2 = c2 + 1 WHERE c1 > 0;
- **UPDATE name WHERE CURRENT OF cursor\_name**
  - It updates the row which the current cursor indicates.
  - e.g. UPDATE t1 WHERE CURRENT OF cursor;
- **UPDATE name RETURNING**
  - It updates multiple rows which satisfy the conditions, and the updated rows can be retrieved in the same way as SELECT statement (API such as SQLFetch ()).



- e.g. UPDATE t1 SET c2 = c2 + 1 WHERE c1 > 0 RETURNING c2;
- **UPDATE name RETURNING .. INTO**
  - It updates row equal to or less than one, and if a single row is updated, it obtains the value to the host variable of RETURNING INTO clause.
  - e.g. UPDATE t1 SET c2 = c2 + 1 WHERE c1 = 0 RETURNING c2 INTO :v1;

## Examples

The following is an example of updating multiple rows which satisfy the condition.

```
gSQL> UPDATE lineitem
      SET l_shipdate = CURRENT_DATE
      WHERE l_returnflag = 'R';
5 rows updated.
```

The following is an example of updating the value of multiple columns.

```
gSQL> UPDATE lineitem
      SET l_shipdate = CURRENT_DATE
        , l_returnflag = 'A'
      WHERE l_returnflag = 'R';
5 rows updated.
```

The following is an example of updating multiple columns by enclosing them with parentheses.

```
gSQL> UPDATE lineitem
      SET ( l_shipdate , l_returnflag )
        = ( CURRENT_DATE, 'A' )
      WHERE l_returnflag = 'R';
5 rows updated.
```

The following is an example of updating the column value by using the subquery.

```
gSQL> UPDATE lineitem
      SET l_discount = ( SELECT MAX(l_discount) + 0.01 FROM lineitem )
      WHERE l_returnflag = 'R';
5 rows updated.
```

The following is an example of updating part of the rows which satisfy the condition by using OFFSET and FETCH clauses.

```
gSQL> UPDATE lineitem
      SET l_discount = l_discount + 0.01
      WHERE l_returnflag = 'R'
      OFFSET 3
      FETCH 2;
2 rows updated.
```

## Compatibility

The SQL standard does not define the following clauses in UPDATE statement.

- <result offset clause>
- <fetch limit clause>

**Table 20-27** SQL standard compatibility

Feature ID	Description	Compatibility
F781	Self-referencing operations	X
T111	Updatable joins, unions, and columns	X

## 20.28 UPDATE name RETURNING

### Function

It updates rows in a table, and retrieves the rows of before or after the update.

### Syntax

```

<update statement: searched> ::=
    UPDATE table_name [ [ AS ] alias_name ]
        SET <set clause> [, ...]
        [ WHERE <search condition> ]
        [ <result offset clause> ]
        [ <fetch limit clause> ]
        <returning clause>
<set clause> ::=
    column_name = { <value expression> | DEFAULT }
    | ( column_name [, ...] ) = ( { <value expression> | DEFAULT } [, ...] )
    | ( column_name [, ...] ) = ( <query expression> )
<result offset clause> ::=
    OFFSET skip_count [ ROW | ROWS ]
<fetch limit clause> ::=
    <fetch first clause>
    | <limit clause>
<fetch first clause> ::=
    FETCH [ FIRST | NEXT ] [ row_count ] [ ROW ONLY | ROWS ONLY ]
<limit clause>
    LIMIT { fetch_row_count | offset_row_count, fetch_row_count | ALL }
<returning clause> ::=
    { RETURN | RETURNING } [ NEW | OLD ] { * | { <value expression> [ [AS] alias_name] } [,
... ] }

```

## Invocation and Access Rules

The user should satisfy the following conditions to perform <update returning query statement>.

- One of the following privileges is required to perform UPDATE statement.
  - UPDATE(columns) ON TABLE for all columns which are targets to be updated
  - (UPDATE or CONTROL TABLE) ON TABLE for the table
  - (UPDATE TABLE or CONTROL SCHEMA) ON SCHEMA for the schema to which the table belongs
  - UPDATE ANY TABLE ON DATABASE
- One of the following privileges for all columns used in RETURNING clause is required.
  - SELECT(columns) ON TABLE for all columns used in RETURNING clause
  - (SELECT or CONTROL TABLE) ON TABLE for the table
  - (SELECT TABLE or CONTROL SCHEMA) ON SCHEMA for the schema to which the table belongs
  - SELECT ANY TABLE ON DATABASE

## Syntax Rules and Parameters

### table\_name

It is the name of a target table whose rows are to be updated.

### [ AS alias\_name ]

It is the alias of table\_name.

### <set clause>

It defines the columns to be updated and its values to be assigned. The number of columns in <set clause > should be as same as the number of values.

For more information, refer to **UPDATE**.

### WHERE <search condition>

It updates the rows which satisfy WHERE condition.

If WHERE condition is not specified, all rows are updated.

For more information about WHERE condition, refer to **where clause** of **SELECT**.

## ⟨result offset clause⟩

It specifies the number of rows to skip from the query result.  
For more information, refer to ⟨result offset clause⟩ of SELECT.

## ⟨fetch limit clause⟩

It specifies the number of rows to fetch in two ways, which are ⟨fetch first clause⟩ and ⟨limit clause⟩.

- ⟨fetch first clause⟩
  - It specifies the number of rows to be fetched.
  - For more information, refer to ⟨fetch first clause⟩ of SELECT statement.
- ⟨limit clause⟩
  - It specifies the number of rows to be fetched, or it simultaneously specifies both the number of rows to be skipped and the number of rows to be fetched.
  - For more information, refer to ⟨limit clause⟩ of SELECT statement.

## ⟨returning clause⟩

It defines the updated rows as a result set, and specifies columns to be retrieved from the result set.

- RETURN and RETURNING are the keywords with the same meaning.
- NEW | OLD
  - NEW: It searches for updated rows based on the row after the update.
  - OLD: It searches for updated rows based on the row before the update.
  - If it is omitted, the default value is NEW.
- ⟨value expression⟩
  - It is as same as ⟨select list⟩ in SELECT statement, but aggregation can not be used.
- [ [AS] alias\_name]
  - It can name ⟨value expression⟩ by using AS clause.

## Description

For more information, refer to [Differences among UPDATE-related Statements](#).

## Examples

The following is an example of obtaining values of the updated rows by using RETURNING clause.

```
gSQL> UPDATE lineitem
      SET l_discount = l_discount + 0.01
      WHERE l_returnflag = 'R'
      RETURNING l_orderkey, l_linenum, l_discount;
```

L_ORDERKEY	L_LINENUMBER	L_DISCOUNT
8	1	.07
9	2	.11
12	5	.05
15	1	.03
16	2	.08

5 rows updated.

The following is an example of obtaining values before the update for the updated rows by using RETURNING OLD clause.

```
gSQL> UPDATE lineitem
      SET l_discount = l_discount + 0.01
      WHERE l_returnflag = 'R'
      RETURNING OLD l_orderkey, l_linenum, l_discount;
```

L_ORDERKEY	L_LINENUMBER	L_DISCOUNT
8	1	.06
9	2	.1
12	5	.04
15	1	.02
16	2	.07

5 rows updated.

## Compatibility

The SQL standard does not define <update returning query statement>.

## 20.29 UPDATE name RETURNING .. INTO

### Function

It updates a single row of a table, and the updated value is obtained into the host variable.

### Syntax

```

<update statement: searched> ::=
    UPDATE table_name [ [ AS ] alias_name ]
        SET <set clause> [, ...]
        [ WHERE <search condition> ]
        [ <result offset clause> ]
        [ <fetch limit clause> ]
        <returning into clause>
    ;
<set clause> ::=
    column_name = { <value expression> | DEFAULT }
    | ( column_name [, ...] ) = ( { <value expression> | DEFAULT } [, ...] )
    | ( column_name [, ...] ) = ( <query expression> )
<result offset clause> ::=
    OFFSET skip_count [ ROW | ROWS ]
<fetch limit clause> ::=
    <fetch first clause>
    | <limit clause>
<fetch first clause> ::=
    FETCH [ FIRST | NEXT ] [ row_count ] [ ROW ONLY | ROWS ONLY ]
<limit clause>
    LIMIT { fetch_row_count | offset_row_count, fetch_row_count | ALL }
<returning into clause> ::=
    { RETURN | RETURNING } [ NEW | OLD ] { * | { <value expression> [ [AS] alias_name] } [,
    ...] } INTO variable_name [, ...]

```

## Invocation and Access Rules

The user should satisfy the following conditions to perform <update returning query statement>.

- One of the following privileges is required to perform UPDATE statement.
  - UPDATE(columns) ON TABLE for all columns which are targets to be updated
  - (UPDATE or CONTROL TABLE) ON TABLE for the table
  - (UPDATE TABLE or CONTROL SCHEMA) ON SCHEMA for the schema to which the table belongs
  - UPDATE ANY TABLE ON DATABASE
- One of the following privileges for all columns used in RETURNING clause is required.
  - SELECT(columns) ON TABLE for all columns used in RETURNING clause
  - (SELECT or CONTROL TABLE) ON TABLE for the table
  - (SELECT TABLE or CONTROL SCHEMA) ON SCHEMA for the schema to which the table belongs
  - SELECT ANY TABLE ON DATABASE

## Syntax Rules and Parameters

### table\_name

It is the name of a target table whose rows are to be updated.

### [ AS alias\_name ]

It is the alias of table\_name.

### <set clause>

It defines the columns to be updated and its values to be assigned. The number of columns in <set clause > should be as same as the number of values.

For more information, refer to **UPDATE**.

### WHERE <search condition>

It updates the rows which satisfy WHERE condition.

If WHERE condition is not specified, all rows are updated.

For more information about WHERE condition, refer to **where clause** of **SELECT**.



## ⟨result offset clause⟩

It specifies the number of rows to skip in the query result.

For more information, refer to ⟨result offset clause⟩ of SELECT.

## ⟨fetch limit clause⟩

It specifies the number of rows to fetch in two ways, which are ⟨fetch first clause⟩ and ⟨limit clause⟩.

- ⟨fetch first clause⟩
  - It specifies the number of rows to be fetched.
  - For more information, refer to ⟨fetch first clause⟩ of SELECT statement.
- ⟨limit clause⟩
  - It specifies the number of rows to be fetched, or it simultaneously specifies both the number of rows to be skipped and the number of rows to be fetched.
  - For more information, refer to ⟨limit clause⟩ of SELECT statement.

## RETURNING .. AS ..

It defines the updated rows as a result set, and specifies columns to be retrieved from the result set.

For more information, refer to ⟨returning clause⟩ of UPDATE name RETURNING.

## INTO variable\_name [, ...]

The number of variables specified in INTO clause should be equal to the number of the expressions specified in RETURNING clause.

The row to be updated should be one or less. If two or more rows are updated, an error occurs.

## Description

For more information, refer to **Differences among UPDATE-related Statements**.

## Example

The following is an example of obtaining column values of the updated rows into the host variables.

- Declare the host variable.

```
gSQL> \VAR v_discount NUMBER
gSQL> UPDATE lineitem
      SET l_discount = l_discount + 0.01
      WHERE l_orderkey = 12 AND l_linenumber = 5
      RETURNING l_discount INTO :v_discount;
V_DISCOUNT
-----
          .05
1 row updated.
```

## Compatibility

In the SQL standard, <update returning into statement> statement does not exist.

## 20.30 UPDATE name WHERE CURRENT OF cursor\_name

### Function

It updates a single row which the current cursor indicates.

### Syntax

```
<update statement: positioned> ::=  
    UPDATE table_name [ [ AS ] alias_name ]  
        SET <set clause> [, ...]  
        WHERE CURRENT OF cursor_name  
    ;
```

### Invocation and Access Rules

The user should satisfy the following conditions to perform <update statement: positioned>.

- One of the following privileges is required to perform UPDATE statement.
  - UPDATE(columns) ON TABLE for all columns which are targets to be updated
  - (UPDATE or CONTROL TABLE) ON TABLE for the table
  - (UPDATE TABLE or CONTROL SCHEMA) ON SCHEMA for the schema to which the table belongs
  - UPDATE ANY TABLE ON DATABASE

### Syntax Rules and Parameters

#### table\_name

It is the name of a table whose rows are to be updated.

## [ AS alias\_name ]

It is the alias of table\_name.

## <set clause>

It defines the columns to be updated and its values to be assigned. The number of columns in <set clause> should be as same as the number of values.

For more information, refer to **UPDATE**.

## cursor\_name

The cursor corresponding to cursor\_name should satisfy the following conditions.

- The cursor should be OPEN. (Refer to **OPEN cursor\_name**.)
- Fetched rows by using the cursor should exist. (Refer to **FETCH cursor\_name**.)
- The query used for the cursor should identify table\_name. (Refer to **DECLARE cursor\_name**.)
- The cursor should be updatable for table\_name. (Refer to **DECLARE cursor\_name**.)

## Description

For more information, refer to **Differences among UPDATE-related Statements**.

## Examples

The following is an example that <update statement: positioned> is performed in interactive SQL (gsq) using the cursor.

- Declare the host variable.

```
gsqSQL> \VAR v_discount NUMBER
```

- Declare the cursor.

```
gsqSQL> DECLARE update_cursor CURSOR FOR
        SELECT l_discount
           FROM lineitem
          WHERE l_orderkey = 8 AND l_linenumber = 1
```

```
FOR UPDATE;
```

Cursor declared.

- Open the cursor.

```
gSQL> OPEN update_cursor;
```

Cursor is open.

- Fetch the row.

```
gSQL> FETCH update_cursor INTO :v_discount;
```

```
V_DISCOUNT
```

```
-----
```

```
      .06
```

1 row fetched.

- Update the current row.

```
gSQL> UPDATE lineitem
```

```
      SET l_discount = l_discount + 0.01
```

```
      WHERE CURRENT OF update_cursor;
```

1 row updated.

- Close the cursor.

```
gSQL> CLOSE update_cursor;
```

Cursor closed.

```
gSQL> COMMIT;
```

Commit complete.

The following is an example of performing <update statement: positioned> by using the cursor in embedded SQL program.

```
{
    ...
    EXEC SQL BEGIN DECLARE SECTION;
        ...
        double v_discount;
        ...
    EXEC SQL END DECLARE SECTION;
    ...
    EXEC SQL DECLARE update_cursor CURSOR FOR
```

```

        SELECT l_discount
        FROM lineitem
        WHERE l_orderkey = 8 AND l_linenumber = 1
        FOR UPDATE;
    ...
EXEC SQL OPEN update_cursor;
    ...
EXEC SQL FETCH NEXT update_cursor INTO :v_discount;
    ...
EXEC SQL UPDATE lineitem
        SET l_discount = l_discount + 0.01
        WHERE CURRENT OF update_cursor;
    ...
EXEC SQL CLOSE update_cursor;
    ...
EXEC SQL COMMIT WORK;
    ...
}

```

## Compatibility

**Table 20-28** SQL standard compatibility

Feature ID	Description	Compatibility
F831	Full cursor update	O
B031	Basic dynamic SQL	O

## For More Information

Refer to `CLOSE cursor_name`.

# Part IV.

---

## PSM Manual

<b>21. Overview of PSM</b>	<b>2,723</b>
21.1 Features of PSM	2,724
Closely Interworking with SQL	2,724
Improving Performance	2,724
Improving Productivity	2,724
Portability	2,724
Easy Maintenance	2,725
21.2 Language Elements	2,726
Data Types	2,726
Variables	2,726
Control Structures	2,726
Subprograms	2,726
21.3 Processing Transaction in PSM	2,727
<b>22. PSM DataTypes</b>	<b>2,729</b>
22.1 Built-in Data Types	2,730
Numeric Types	2,730
CHARACTER STRING Types	2,730
BINARY STRING Type	2,730
DATE/TIME Type	2,731
INTERVAL Type	2,731
BOOLEAN Type	2,731
ROWID Type	2,731
Declaring Built-in Data Type Variables	2,731
22.2 Attribute Data Types	2,733
%TYPE	2,733
%ROWTYPE	2,733
Constraint Attributes Inheritance	2,734
22.3 User-defined Record Type	2,735
22.4 User-defined Collection Type	2,737
Associative Array	2,737
Assign Values to Collection Variables	2,739
Collection Method	2,742
22.5 SYS_REFCURSOR	2,745
<b>23. PSM Control Statements</b>	<b>2,747</b>
23.1 Assignment	2,748
Assignment Target	2,748
Assigning Expression	2,748
Assignment Compatibility	2,750



23.2	PL Block	2,752
	PL Block Configuration	2,752
23.3	NULL Statement	2,755
23.4	Testing Conditions	2,756
	IF	2,756
	CASE	2,757
23.5	Iterative Control	2,759
	Basic Loop	2,759
	FOR Loop	2,760
	WHILE Loop	2,761
23.6	Sequential Control	2,763
	GOTO	2,763
	CONTINUE	2,766
	EXIT	2,767
23.7	Error Handling	2,769
	Errors at Compile Time	2,769
	Errors at Run-time	2,771
	Cursor Attributes	2,772
	EXCEPTION Handling	2,775
	PRAGMA EXCEPTION_INIT	2,780
	DBMS_STANDARD.RAISE_APPLICATION_ERROR	2,782
<b>24.</b>	<b>PSM Cursor Statements</b>	<b>2,783</b>
24.1	Declaration	2,784
24.2	OPEN	2,788
24.3	FETCH	2,789
24.4	CLOSE	2,791
24.5	EXPLICIT CURSOR ATTRIBUTES	2,792
24.6	IMPLICIT_CURSOR_ATTRIBUTES	2,794
24.7	CURSOR VARIABLES	2,796
	OPEN and Close Cursor Variables	2,798
	Fetching Data With Cursor Variables	2,799
	Assign Values to Cursor Variables	2,799
<b>25.</b>	<b>Using PSM Subprograms</b>	<b>2,803</b>
25.1	Anonymous PL Block	2,804
25.2	Nested Procedure	2,805
25.3	Nested Function	2,807
25.4	Schema-level Procedure	2,808
	Creating Schema-level Procedure	2,808
	Using Schema-level Procedure	2,809

Dropping Schema-level Procedure .....	2,811
Recompiling Schema-level Procedure .....	2,811
25.5 Schema-level Function .....	2,813
Creating Schema-level Function .....	2,813
Using Schema-level Function .....	2,813
Dropping Schema-level Function .....	2,814
25.6 Built-in Procedures .....	2,816
<b>26. Using SQLs in PSM .....</b>	<b>2,819</b>
26.1 Static SQLs .....	2,820
SELECT .....	2,820
INSERT .....	2,824
UPDATE .....	2,827
DELETE .....	2,828
RETURNING INTO .....	2,829
COMMIT, ROLLBACK, SAVEPOINT .....	2,834
26.2 Dynamic SQL .....	2,837
EXECUTE IMMEDIATE .....	2,837
OPEN FOR, FETCH and CLOSE .....	2,839
<b>27. PSM Packages .....</b>	<b>2,843</b>
27.1 Definition .....	2,844
27.2 Features .....	2,844
27.3 Specification .....	2,845
Creating Package Specification .....	2,846
Creating Package Body .....	2,846
Package State .....	2,848
<b>28. PSM Language Element References .....</b>	<b>2,849</b>
28.1 Assignment Statement .....	2,850
Function .....	2,850
Syntax .....	2,850
Invocation and Access Rules .....	2,850
Syntax Rules and Parameters .....	2,850
Description .....	2,851
Examples .....	2,851
Compatibility .....	2,852
For More Information .....	2,853
28.2 Basic LOOP Statement .....	2,854
Function .....	2,854
Syntax .....	2,854

Invocation and Access Rules .....	2,854
Syntax Rules and Parameters .....	2,854
Description .....	2,854
Examples .....	2,855
Compatibility .....	2,855
For More Information .....	2,855
28.3 Block (BEGIN .. END) .....	2,856
Function .....	2,856
Syntax .....	2,856
Invocation and Access Rules .....	2,857
Syntax Rules and Parameters .....	2,857
Description .....	2,858
Examples .....	2,858
Compatibility .....	2,858
For More Information .....	2,859
28.4 CASE Statement .....	2,860
Function .....	2,860
Syntax .....	2,860
Invocation and Access Rules .....	2,860
Syntax Rules and Parameters .....	2,861
Description .....	2,861
Examples .....	2,861
Compatibility .....	2,862
28.5 CLOSE Statement .....	2,863
Function .....	2,863
Syntax .....	2,863
Invocation and Access Rules .....	2,863
Syntax Rules and Parameters .....	2,863
Description .....	2,863
Examples .....	2,864
Compatibility .....	2,864
For More Information .....	2,864
28.6 Collection Method Invocation .....	2,865
Function .....	2,865
Syntax .....	2,865
Invocation and Access Rules .....	2,865
Syntax Rules and Parameters .....	2,865
Description .....	2,866
Examples .....	2,866

For More Information	2,868
28.7 COLLECTION Variable Declaration	2,869
Function	2,869
Syntax	2,869
Invocation and Access Rules	2,869
Syntax Rules and Parameters	2,870
Description	2,870
Examples	2,870
Compatibility	2,872
For More Information	2,872
28.8 CONTINUE Statement	2,873
Function	2,873
Syntax	2,873
Invocation and Access Rules	2,873
Syntax Rules and Parameters	2,873
Description	2,874
Examples	2,874
Compatibility	2,875
For More Information	2,875
28.9 Cursor FOR LOOP Statement	2,876
Function	2,876
Syntax	2,876
Invocation and Access Rules	2,876
Syntax Rules and Parameters	2,877
Description	2,877
Examples	2,877
For More Information	2,879
28.10 Cursor Variable Declaration	2,880
Function	2,880
Syntax	2,880
Invocation and Access Rules	2,880
Syntax Rules and Parameters	2,880
Description	2,880
Examples	2,881
For More Information	2,881
28.11 DELETE Statement Extension	2,882
Function	2,882
Syntax	2,882
Invocation and Access Rules	2,883

Syntax Rules and Parameters	2,883
Description	2,883
Examples	2,883
For More Information	2,884
28.12 EXCEPTION_INIT Pragma	2,885
Function	2,885
Syntax	2,885
Invocation and Access Rules	2,885
Syntax Rules and Parameters	2,885
Description	2,885
Examples	2,886
Compatibility	2,886
For More Information	2,886
28.13 Exception Declaration	2,887
Function	2,887
Syntax	2,887
Invocation and Access Rules	2,887
Syntax Rules and Parameters	2,887
Description	2,887
Examples	2,887
Compatibility	2,888
For More Information	2,888
28.14 Exception Handler	2,889
Function	2,889
Syntax	2,889
Invocation and Access Rules	2,889
Syntax Rules and Parameters	2,889
Description	2,890
Examples	2,890
Compatibility	2,891
For More Information	2,891
28.15 EXECUTE IMMEDIATE Statement	2,892
Function	2,892
Syntax	2,892
Invocation and Access Rules	2,892
Syntax Rules and Parameters	2,893
Description	2,894
Examples	2,895
28.16 EXIT Statement	2,896

Function	2,896
Syntax	2,896
Invocation and Access Rules	2,896
Syntax Rules and Parameters	2,896
Description	2,896
Examples	2,897
Compatibility	2,897
28.17 Explicit Cursor Attribute	2,898
Function	2,898
Syntax	2,898
Invocation and Access Rules	2,898
Syntax Rules and Parameters	2,898
Description	2,898
Examples	2,899
Compatibility	2,900
28.18 Explicit Cursor Declaration and Definition	2,901
Function	2,901
Syntax	2,901
Invocation and Access Rules	2,901
Syntax Rules and Parameters	2,901
Description	2,902
Examples	2,903
Compatibility	2,904
For More Information	2,904
28.19 FETCH Statement	2,905
Function	2,905
Syntax	2,905
Invocation and Access Rules	2,905
Syntax Rules and Parameters	2,905
Description	2,906
Examples	2,906
Compatibility	2,907
For More Information	2,907
28.20 FOR LOOP Statement	2,908
Function	2,908
Syntax	2,908
Invocation and Access Rules	2,908
Syntax Rules and Parameters	2,908
Description	2,909

Examples	2,909
Compatibility	2,910
For More Information	2,910
28.21 Function Declaration and Definition	2,911
Function	2,911
Syntax	2,911
Invocation and Access Rules	2,911
Syntax Rules and Parameters	2,911
Description	2,912
Examples	2,912
Compatibility	2,913
For More Information	2,913
28.22 GOTO Statement	2,914
Function	2,914
Syntax	2,914
Invocation and Access Rules	2,914
Syntax Rules and Parameters	2,914
Description	2,914
Examples	2,915
Compatibility	2,915
For More Information	2,915
28.23 IF Statement	2,916
Function	2,916
Syntax	2,916
Invocation and Access Rules	2,916
Syntax Rules and Parameters	2,916
Description	2,917
Examples	2,917
Compatibility	2,917
28.24 Implicit Cursor Attribute	2,918
Function	2,918
Syntax	2,918
Invocation and Access Rules	2,918
Description	2,918
Examples	2,918
Compatibility	2,919
28.25 INSERT Statement Extension	2,920
Function	2,920
Syntax	2,920

Invocation and Access Rules	2,920
Syntax Rules and Parameters	2,921
Description	2,921
Examples	2,921
Compatibility	2,922
28.26 INSERT INTO ... UPDATE Statement Extension	2,923
Function	2,923
Syntax	2,923
Invocation and Access Rules	2,924
Syntax Rules and Parameters	2,924
Description	2,924
Examples	2,925
Compatibility	2,927
28.27 NULL Statement	2,928
Function	2,928
Syntax	2,928
Invocation and Access Rules	2,928
Description	2,928
Examples	2,928
Compatibility	2,929
28.28 OPEN Statement	2,930
Function	2,930
Syntax	2,930
Invocation and Access Rules	2,930
Syntax Rules and Parameters	2,930
Description	2,930
Examples	2,931
Compatibility	2,931
For More Information	2,932
28.29 OPEN FOR Statement	2,933
Function	2,933
Syntax	2,933
Invocation and Access Rules	2,933
Syntax Rules and Parameters	2,933
Description	2,933
Examples	2,934
Compatibility	2,935
For More Information	2,935
28.30 Procedure Call	2,936



Function	2,936
Syntax	2,936
Invocation and Access Rules	2,936
Syntax Rules and Parameters	2,936
Description	2,937
Examples	2,937
Compatibility	2,938
28.31 Procedure Declaration and Definition	2,939
Function	2,939
Syntax	2,939
Invocation and Access Rules	2,939
Syntax Rules and Parameters	2,939
Description	2,940
Examples	2,940
Compatibility	2,940
For More Information	2,940
28.32 RAISE Statement	2,941
Function	2,941
Syntax	2,941
Invocation and Access Rules	2,941
Syntax Rules and Parameters	2,941
Description	2,941
Examples	2,942
Compatibility	2,943
For More Information	2,943
28.33 Record Variable Declaration	2,944
Function	2,944
Syntax	2,944
Invocation and Access Rules	2,944
Syntax Rules and Parameters	2,944
Description	2,945
Examples	2,945
Compatibility	2,945
28.34 RETURN Statement	2,946
Function	2,946
Syntax	2,946
Invocation and Access Rules	2,946
Syntax Rules and Parameters	2,946
Description	2,946

Examples	2,947
Compatibility	2,947
28.35 RETURNING INTO clause	2,948
Function	2,948
Syntax	2,948
Invocation and Access Rules	2,948
Syntax Rules and Parameters	2,948
Description	2,948
Examples	2,949
Compatibility	2,949
28.36 %ROWTYPE Attribute	2,950
Function	2,950
Syntax	2,950
Invocation and Access Rules	2,950
Syntax Rules and Parameters	2,950
Description	2,950
Examples	2,951
Compatibility	2,951
28.37 Scalar Variable Declaration	2,952
Function	2,952
Syntax	2,952
Invocation and Access Rules	2,952
Syntax Rules and Parameters	2,952
Description	2,953
Examples	2,953
Compatibility	2,954
28.38 SELECT INTO Statement	2,955
Function	2,955
Syntax	2,955
Invocation and Access Rules	2,955
Syntax Rules and Parameters	2,955
Description	2,955
Examples	2,956
Compatibility	2,956
28.39 SQLCODE Function	2,957
Function	2,957
Syntax	2,957
Invocation and Access Rules	2,957
Syntax Rules and Parameters	2,957

Description .....	2,957
Examples .....	2,957
Compatibility .....	2,958
28.40 SQLERRM Function .....	2,959
Function .....	2,959
Syntax .....	2,959
Invocation and Access Rules .....	2,959
Syntax Rules and Parameters .....	2,959
Description .....	2,959
Examples .....	2,959
Compatibility .....	2,960
28.41 %TYPE Attribute .....	2,961
Function .....	2,961
Syntax .....	2,961
Invocation and Access Rules .....	2,961
Syntax Rules and Parameters .....	2,961
Description .....	2,961
Examples .....	2,962
Compatibility .....	2,962
28.42 UPDATE Statement Extension .....	2,963
Function .....	2,963
Syntax .....	2,963
Invocation and Access Rules .....	2,964
Syntax Rules and Parameters .....	2,964
Description .....	2,964
Examples .....	2,964
Compatibility .....	2,965
28.43 WHILE LOOP Statement .....	2,966
Function .....	2,966
Syntax .....	2,966
Invocation and Access Rules .....	2,966
Syntax Rules and Parameters .....	2,966
Description .....	2,966
Examples .....	2,967
Compatibility .....	2,967
For More Information .....	2,967
<b>29. PSM SQL References .....</b>	<b>2,969</b>
29.1 ALTER FUNCTION .....	2,970
Function .....	2,970

Syntax	2,970
Invocation and Access Rules	2,970
Syntax Rules and Parameters	2,970
Description	2,970
Examples	2,971
Compatibility	2,971
For More Information	2,971
29.2 ALTER PACKAGE	2,972
Function	2,972
Syntax	2,972
Invocation and Access Rules	2,972
Syntax Rules and Parameters	2,972
Description	2,973
Examples	2,973
Compatibility	2,973
For More Information	2,973
29.3 ALTER PROCEDURE	2,974
Function	2,974
Syntax	2,974
Invocation and Access Rules	2,974
Syntax Rules and Parameters	2,974
Description	2,974
Examples	2,975
Compatibility	2,975
For More Information	2,976
29.4 CALL Statement	2,977
Function	2,977
Syntax	2,977
Invocation and Access Rules	2,977
Syntax Rules and Parameters	2,977
Description	2,978
Examples	2,978
Compatibility	2,979
29.5 CREATE FUNCTION	2,980
Function	2,980
Syntax	2,980
Invocation and Access Rules	2,980
Syntax Rules and Parameters	2,981
Description	2,982

Examples	2,982
Compatibility	2,983
For More Information	2,984
29.6 CREATE PACKAGE	2,985
Function	2,985
Syntax	2,985
Invocation and Access Rules	2,985
Syntax Rules and Parameters	2,986
Description	2,987
Examples	2,987
Compatibility	2,987
For More Information	2,987
29.7 CREATE PACKAGE BODY	2,989
Function	2,989
Syntax	2,989
Invocation and Access Rules	2,989
Syntax Rules and Parameters	2,990
Description	2,991
Examples	2,991
Compatibility	2,992
For More Information	2,992
29.8 CREATE PROCEDURE	2,993
Function	2,993
Syntax	2,993
Invocation and Access Rules	2,993
Syntax Rules and Parameters	2,994
Description	2,995
Examples	2,995
Compatibility	2,996
For More Information	2,997
29.9 DROP FUNCTION	2,998
Function	2,998
Syntax	2,998
Invocation and Access Rules	2,998
Syntax Rules and Parameters	2,998
Description	2,999
Examples	2,999
Compatibility	2,999
For More Information	2,999

29.10 DROP PACKAGE .....	3,001
Function .....	3,001
Syntax .....	3,001
Invocation and Access Rules .....	3,001
Syntax Rules and Parameters .....	3,001
Description .....	3,002
Examples .....	3,002
Compatibility .....	3,002
For More Information .....	3,002
29.11 DROP PROCEDURE .....	3,003
Function .....	3,003
Syntax .....	3,003
Invocation and Access Rules .....	3,003
Syntax Rules and Parameters .....	3,003
Description .....	3,004
Examples .....	3,004
Compatibility .....	3,004
For More Information .....	3,005

**21.**

---

## **Overview of PSM**

## 21.1 Features of PSM

### Closely Interworking with SQL

GOLDILOCKS PSM can closely interworks with GOLDILOCKS SQL.

- It supports all data types supported by GOLDILOCKS SQL.
- It supports an attribute type (%TYPE, %ROWTYPE), so a flexible tables and column types are available.
- It supports all operators and built-in functions supported by GOLDILOCKS SQL.
- It supports all DML, DCL (COMMIT/ROLLBACK) supported by GOLDILOCKS SQL.
- It supports SQL SELECT statements by declaring a cursor and using OPEN, FETCH, CLOSE statements.
- It supports SQL DDL statements through the dynamic SQL feature.

### Improving Performance

GOLDILOCKS PSM is operated only within a server, so it reduces the number of communications between the user application and the DBMS server. Therefore, the overall performance is improved.

### Improving Productivity

The language of GOLDILOCKS PSM is quite similar to that of script, a less effort is required to write a code for the desired feature. The time of writing a client application can be reduced if the procedure and function is created by modularizing the user's work logic.

### Portability

Procedures and functions created by GOLDILOCKS PSM can also be used in ODBC, JDBC, an embedded SQL, and various development tools in the same way. Also, it can be easily transplanted in a different platform regardless of the platform type of server or a client.



## Easy Maintenance

GOLDILOCKS PSM is implemented into a single module in a server from each similar logics in separate clients. Therefore, it is easy to manage, and enable to modify when it is in need even during the module is in use.

## 21.2 Language Elements

### Data Types

GOLDILOCKS PSM provides all built-in data types provided by GOLDILOCKS SQL, and it even supports user defined records and collection types.

For more information, refer to **PSM DataTypes**.

### Variables

Required variables declared by a user in GOLDILOCKS PSM can be used in all expressions.

For more information, refer to the followings.

- **Declarative Part**
- **Assignment**

### Control Structures

GOLDILOCKS PSM supports most of decision branch statements, unconditional branch statements (GOTO), loop statement for repeated executions which were provided by a general script language.

For more information, refer to **PSM Control Statements**.

### Subprograms

GOLDILOCKS PSM subprogram is a PSM block with a name and it can be repeatedly performed. If a subprogram has an argument, then it can be performed by being given different arguments when each time it is called.

Subprogram is either in a procedure form or a function form, and the function form has a return value. It also supports a nested subprogram which is declared in a specific block and used within it.

For more information, refer to **Using PSM Subprograms**.

## 21.3 Processing Transaction in PSM

A database transaction is a work unit which consists of one or more of SQL statements and it can not be disassembled. The followings are SQL statements which use transactions in GOLDILOCKS database.

- DML except for SELECT statements
- All DDL

A transaction starts in the following cases.

- When performing SQL which uses a transaction for the first time immediately after the connection.
- When performing SQL which uses a transaction for the first time since COMMIT or ROLLBACK

A transaction ends when a user performs COMMIT or ROLLBACK, or terminates the connection.

A subprogram module created by GOLDILOCKS PSM is a statement which does not uses its own transaction, so a new transaction does not occur when the subprogram is called.

However, to guarantee atomicity of the SQL statement, the the available SQL types in a subprogram may vary depending on the case of calling the subprogram.

- When a user directly calls a subprogram module by using CALL statement, or performs an anonymous block
  - A superordinate statement does not exists, so all kinds of SQL can be used within a subprogram and COMMIT/ROLLBACK is also allowed.
- When a subprogram module is used within a DML statement (INSERT/UPDATE/DELETE) except for SELECT
  - A superordinate statement has a transaction, so all kinds of SQL can be used within a subprogram. However, to guarantee the atomicity of the superordinate statement, neither COMMIT nor ROLLBACK is allowed.
- When a subprogram module is called within a SELECT statement
  - A superordinate statement does not use a transaction, so any kind of SQL using a transaction can not be used even within a called subprogram, nor is COMMIT/ROLLBACK allowed. Only SELECT statement is allowed.



22.

---

## PSM DataTypes

## 22.1 Built-in Data Types

GOLDILOCKS PSM supports all basic data types provided by GOLDILOCKS SQL in the same way.

The followings are the basic data types.

For more information, refer to **Data Type**.

### Numeric Types

- NUMBER
- NUMERIC
- FLOAT
- NATIVE\_INTEGER
- NATIVE\_DOUBLE

### CHARACTER STRING Types

- CHARACTER (CHAR)
- CHARACTER VARYING (VARCHAR, VARCHAR2)
- CHARACTER LONG VARYING (LONG VARCHAR)



Exceptionally, for the compatibility with other database, GOLDILOCKS PSM provides VARCHAR types (VARCHAR2, CHAR VARYING, CHARACTER VARYING) whose precision is not specified, and which is not supported by GOLDILOCKS SQL.

This type can not be used when declaring an ordinary variable, but it can be used only when declaring an argument of a subprogram, a return type or an argument of a cursor. If this type is specified, then the argument and the return type is determined as a type with the biggest value among VARCHAR types. (precision = 4000)

### BINARY STRING Type

- BINARY
- BINARY VARYING (VARBINARY)
- BINARY LONG VARYING (LONG VARBINARY)

## DATE/TIME Type

- DATE
- TIME [WITH/WITHOUT TIME ZONE]
- TIMESTAMP [WITH/WITHOUT TIME ZONE]

## INTERVAL Type

- INTERVAL YEAR
- INTERVAL MONTH
- INTERVAL YEAR TO MONTH
- INTERVAL DAY
- INTERVAL HOUR
- INTERVAL MINUTE
- INTERVAL SECOND
- INTERVAL DAY TO HOUR
- INTERVAL DAY TO MINUTE
- INTERVAL DAY TO SECOND
- INTERVAL HOUR TO MINUTE
- INTERVAL HOUR TO SECOND
- INTERVAL MINUTE TO SECOND

## BOOLEAN Type

BOOLEAN

## ROWID Type

ROWID

## Declaring Built-in Data Type Variables

A variable can be declared in each declaration section within an anonymous block, a procedure or a function.

```
DECLARE
  V_MSG VARCHAR(20) := 'HELLO, WORLD!';
BEGIN
  DBMS_OUTPUT.PUT_LINE( 'My First Message Is : ' || V_MSG );
END;
/
```

For more information, refer to [Built-in Data Type References](#).



## 22.2 Attribute Data Types

It is a data type which is used when specifying types of other PSM variables, cursors, tables or a specific column in a table.

If an attribute variable or a target object (table) of a function is altered, then PSM (procedure, function) is automatically compiled again according to the altered type and it is applied.

### %TYPE

It is used when specifying a type of other variables or a column type of a specific table. The following objects can be referenced.

- Scalar type (Including built-in data type) variables
- User defined record type variables
- A specific field of a record type variable
- Collection type variables
- A specific field of a collection type variable
- A specific column of a table

%TYPE is used as follows.

```
CREATE TABLE EMP ( ID INTEGER, NAME VARCHAR(32) );
INSERT INTO EMP VALUES ( 1001, 'Tom Jackson' );
COMMIT;
DECLARE
    V_NAME EMP.NAME%TYPE;
BEGIN
    SELECT NAME INTO V_NAME FROM EMP;
    DBMS_OUTPUT.PUT_LINE( 'EMP.NAME = ' || V_NAME );
END;
/
```

### %ROWTYPE

It is used to specify the structure of a specific table, or the record type as same as the returned type of a specific cursor. It can refer to the following objects.

- Table
- Cursor
- Cursor variable

Neither the record type variable nor collection type variable can be a target of %ROWTYPE.

The following is an example of using %ROWTYPE.

```

DECLARE
  V_EMP EMP%ROWTYPE;
BEGIN
  SELECT * INTO V_EMP FROM EMP WHERE ID = 1001;
  DBMS_OUTPUT.PUT_LINE( 'Name of ID 1001 Is : ' || V_EMP.NAME );
END;
/

```

## Constraint Attributes Inheritance

The constraint attributes of variables declared as an attribute type inherits the constraint attributes of the reference target as follows.

**Table 22-1** Whether to inherit constraints of the attribute types

Attribute type	Reference target	NOT NULL	Default value
%TYPE	Scalar variable	O	X
	Record type variable	O	O
	A specific field of a record type variable	O	X
	Collection type variable - scalar element	O	X
	Collection type variable - record element	O	O
	A specific field of a collection type variable	O	X
	A specific column of a table	X	X
%ROWTYPE	Table	X	X
	Cursor	X	X
	Cursor Variable	X	X

## 22.3 User-defined Record Type

The record type variable is a complex structure type which consists of several fields of each different type. A record type variable can be created by copying types of other tables or cursors by using %ROWTYPE, or by declaring a data structure which is appropriate to a specific purpose by a user.

A user defined record type can be defined by using TYPE keyword in PSM declarative part as follows. Each field can optionally specify a NOT NULL constraint and a default value.

```
DECLARE
  TYPE MY_EMP_TYPE IS RECORD
  (
    ID INTEGER := 99999,
    NAME VARCHAR(32) NOT NULL DEFAULT 'anonymous'
  );
  V_EMP MY_EMP_TYPE;
BEGIN
  SELECT ID, NAME INTO V_EMP.ID, V_EMP.NAME FROM EMP;
  DBMS_OUTPUT.PUT_LINE('ID = ' || V_EMP.ID);
  DBMS_OUTPUT.PUT_LINE('NAME = ' || V_EMP.NAME);
END;
/
```

The following is an example of using it in a nested procedure or in a nested function.

```
DECLARE
  TYPE MY_EMP_TYPE IS RECORD
  (
    ID INTEGER := 99999,
    NAME VARCHAR(32) NOT NULL DEFAULT 'anonymous'
  );
  V_EMP MY_EMP_TYPE;
  PROCEDURE SET_EMP( A_EMP IN OUT MY_EMP_TYPE )
  IS
  BEGIN
    DBMS_OUTPUT.PUT_LINE('ID = ' || A_EMP.ID);
    DBMS_OUTPUT.PUT_LINE('NAME = ' || A_EMP.NAME);
    SELECT ID, NAME INTO A_EMP.ID, A_EMP.NAME FROM EMP;
  END;
BEGIN
```

```
SET_EMP( V_EMP );  
DBMS_OUTPUT.PUT_LINE(' ID = ' || V_EMP.ID);  
DBMS_OUTPUT.PUT_LINE(' NAME = ' || V_EMP.NAME);  
END;  
/
```

A user defined record type can be used as an argument or a returned type of a general regional variable, a nested procedure, or a nested function. However, it can not be used as an argument or a returned type of a schema-level procedure or a schema-level function.

## 22.4 User-defined Collection Type

User defined collection type is a kind of an array structure which stores one or more data. GOLDILOCKS PSM supports an associative array type which can be stored as key/value pair among collection types.

The following is a basic SYNTAX to declare an associative type.

```
TYPE <type_name> IS TABLE OF <element_data_type> INDEX BY <index_key_data_type>
```

- <type\_name> is a user defined name for the type.
- <element\_data\_type> specifies a data type of a value which configures an array.
- <index\_key\_data\_type> specifies a data type of an index key which explores for an element.

For example, if the information corresponding to (number) is in form of (name, age), then a table can be created and stored in a database as follows.

```
CREATE TABLE INFO
(
  NO INTEGER,
  NAME VARCHAR(20),
  AGE INTEGER
)
CREATE UNIQUE INDEX IDX_NO ON INFO (NO)
```

- If the information above is stored as an associative array, then its configuration is as follows.
  - Index\_key corresponds to a number (NO).
  - Element\_data consists of a name (NAME) and an age (AGE).

An associative array variable to store it is defined within a real PSM as follows.

```
TYPE rec IS RECORD (NAME VARCHAR(20), AGE INTEGER);
TYPE info IS TABLE OF rec INDEX BY INTEGER;
```

For more information, refer to **COLLECTION Variable Declaration**.

### Associative Array

An associative array type variable has a data type key specified in an index clause, and it is a PSM variable which can store a value of element data type specified in TABLE OF clause in one or more values in a key/value form.

- The features of an associative array type of GOLDILOCKS PSM is as follows.
  - It has an exploring key in a data type form specified in INDEX BY clause, and it is automatically sorted and stored.
  - It consists of elements specified in TABLE OF clause.
  - It provides exploring functions called as collection methods.
  - It is stored in a replace form when storing an element in an existing index key.
  - The maximum storage size is restricted to the available size of MEMORY\_TEMP\_TBS\_SIZE.

The following is an example of declaring an element type as an SQL data type, and inserting data.

```
gSQL> CREATE TABLE T1
(
  C1 VARCHAR(20),
  C2 VARCHAR(20)
);
Table created.
gSQL> DECLARE
  TYPE rec IS TABLE OF VARCHAR(20) INDEX BY VARCHAR(10);
  V1 rec;
BEGIN
  V1('aa') := 'Dog';
  V1('bb') := 'Cat';
  INSERT INTO T1 VALUES ( V1('aa'), V1('bb') );
END;
/
Anonymous PL block executed.
gSQL> SELECT * FROM T1;
C1  C2
--- ---
Dog Cat
1 row selected.
```

The following is an example of having a record type as an element.

```
gSQL> CREATE TABLE T1
(
  C1 VARCHAR(20),
  C2 VARCHAR(20)
);
Table created.
gSQL> DECLARE
  TYPE rec IS TABLE OF T1%ROWTYPE INDEX BY VARCHAR(10);
```

```

V1 rec;
BEGIN
  V1('person1').C1 := 'seoul';
  V1('person1').C2 := '12';
  V1('person2').C1 := 'busan';
  V1('person2').C2 := '24';
  INSERT INTO T1 VALUES V1('person1'), V1('person2');
END;
/
Anonymous PL block executed.
gSQL> SELECT * FROM T1;
C1    C2
----- --
seoul 12
busan 24
2 rows selected.

```

- The following is a data type which can be specified in an index key of an associative array of GOLDLOCKS PSM.
  - INTEGER
  - LONG
  - CHAR
  - VARCHAR
- The following is a data type which can be used as an element type of an associative array of GOLDLOCKS PSM.
  - SQL Data Type
  - %TYPE
  - %ROWTYPE
  - User defined Record Type

For more information, refer to **Built-in Data Types**, **%TYPE**, **%ROWTYPE**, **User Defined Record Type**.

## Assign Values to Collection Variables

The following rules are applied when assigning values to collection variables.

- The rules as same as <Assign Statement> is applied to an element assignment.
- To assign values to the entire collection variable, the types of collection variables should be same.
- When assigning an element of a collection variable, it is operated according to the element data type as follows.

- Assigning a user defined type element is allowed among same type.
- Else, it is allowed to assign when data types of a field configuring an element are compatible at a run-time.

The following is an example of an error due to the assignment of a different type.

```

DECLARE
  TYPE udr1 IS RECORD (F1 INTEGER, F2 VARCHAR(20));
  TYPE udr2 IS RECORD (F1 INTEGER, F2 VARCHAR(20));
  TYPE rec1 IS TABLE OF udr1 INDEX BY VARCHAR(10);
  TYPE rec2 IS TABLE OF udr2 INDEX BY VARCHAR(10);
  V1 rec1;
  V2 rec2;
BEGIN
  V2('person1').F1 := 24;
  V2('person1').F2 := 'seoul korea';
  V1 := V2;
END;
/
ERR-HY000(17032): PSM compilation error :
(1) at (14:9): ERR-HY000(17007): invalid expression

```

In the example above, configuration of each field of an element which consists of user defined type is same. However, the variable types are different, so the assignment fails.

The following is an example of succeeding in an assignment by using the same type.

```

DECLARE
  TYPE udr1 IS RECORD (F1 INTEGER, F2 VARCHAR(20));
  TYPE rec1 IS TABLE OF udr1 INDEX BY VARCHAR(10);
  V1 rec1;
  V2 rec1;
BEGIN
  V2('person1').F1 := 24;
  V2('person1').F2 := 'seoul korea';
  V1 := V2;
END;
/
Anonymous PL block executed.

```

Assignment of an associative type in an element unit is allowed only when the data types of elements are compatible.



Refer to the following example.

```

gSQL> CREATE TABLE T1
(
  c1 VARCHAR(20),
  c2 VARCHAR(20)
);
Table created.
gSQL> DECLARE
TYPE record_org1 IS RECORD (f1 VARCHAR(20), f2 VARCHAR(20));
TYPE rec1 IS TABLE OF t1%rowtype INDEX BY VARCHAR(10);
TYPE rec2 IS TABLE OF record_org1 INDEX BY VARCHAR(10);
v1 record_org1;
v2 rec1;
v3 rec2;
v4 t1%rowtype;
BEGIN

  -- From record_org1 type to %rowtype
  V2('first') := v1;
  -- From record_org1 type to record_org1 type
  V3('first') := v1;

  -- From t1%rowtype to record_org1 type
  V3('second') := V2('first');
END;
/
Anonymous PL block executed.

```

An associative type variable is stored in a volatile memory space, and the user accessible TEMP TABLESPACE should be extended when the space is insufficient. The following is an example of an error due to the memory insufficiency.

```

DECLARE
TYPE rec IS TABLE OF t1%rowtype INDEX BY varchar(20);
v1 rec;
BEGIN
  BEGIN
    FOR i IN 1 .. 100000
    LOOP
      v1(i).c1 := i;
    
```

```

        v1(i).c2 := i;
    END LOOP;
    EXCEPTION WHEN OTHERS THEN
        dbms_output.put_line('error: count=' || v1.count());
        dbms_output.put_line('sqlcode=' || SQLCODE);
        dbms_output.put_line('sqlmsg =' || SQLERRM);
    END;
    dbms_output.put_line('v1.count=' || v1.count());
END;
/
error: count=95004
sqlcode=-14015
sqlmsg =[SUNJESOFT][PSM][GOLDILOCKS]there is no extendible datafile in tablespace
'MEM_TEMP_TBS'
v1.count=95004
Anonymous PL block executed.

```

## Collection Method

A collection method is a function or a procedure which is provided to easily operate a collection type variable. Associative array provides the following methods.

**Table 22-2** Collection method

Method	Type	Input argument	Return type	Description
FIRST	Function	X	Index key data type	It returns the first index key.
LAST	Function	X	Index key data type	It returns the last index key.
COUNT	Function	X	INTEGER	It returns the number of elements.
EXISTS	Function	O	BOOLEAN	It returns whether an index key exists or not.
PRIOR	Function	O	Index key data type	It returns an index key prior to the input index key.
NEXT	Function	O	Index key data type	It returns an index key next to the input index key.
DELETE	Procedure	O	N/A	It deletes an element corresponding to the input index key.

A collection method is used as follows.

```

gSQL> CREATE TABLE T1
(
  C1 VARCHAR(20),
  C2 VARCHAR(20)
);
Table created.
gSQL> DECLARE
  TYPE rec IS TABLE OF T1%ROWTYPE INDEX BY VARCHAR(10);
  V1 rec;
BEGIN
  V1('person1').C1 := 'seoul';
  V1('person1').C2 := '12';
  V1('person2').C1 := 'busan';
  V1('person2').C2 := '24';
  V1('person3').C1 := 'Daegu';
  V1('person3').C2 := '36';
  -- First method
  DBMS_OUTPUT.PUT_LINE('First Index Key = ' || V1.first() );
  -- Last method
  DBMS_OUTPUT.PUT_LINE('Last Index Key = ' || V1.last() );
  -- Count method
  DBMS_OUTPUT.PUT_LINE('Count of element = ' || V1.count() );
  -- Prior Method
  DBMS_OUTPUT.PUT_LINE('Prior (person1) = ' || V1.prior('person1') ); -- return NULL
  DBMS_OUTPUT.PUT_LINE('Prior (person3) = ' || V1.prior('person3') );
  -- Next Method
  DBMS_OUTPUT.PUT_LINE('Next (person1) = ' || V1.next('person1') );
  DBMS_OUTPUT.PUT_LINE('Next (person3) = ' || V1.next('person3') ); -- return NULL
  -- Exists Method
  DBMS_OUTPUT.PUT_LINE('Exists (person2) = ' || V1.exists('person2') );
  -- Delete Method
  V1.delete('person2');
  -- Exists Method
  DBMS_OUTPUT.PUT_LINE('After delete, Exists (person2) = ' || V1.exists('person2') );
END;
/
First Index Key = person1
Last Index Key = person3
Count of element = 3
Prior (person1) =
Prior (person3) = person2

```

```
Next (person1) = person2
Next (person3) =
Exists (person2) = TRUE
After delete, Exists (person2) = FALSE
Anonymous PL block executed.
```

If a delete procedure deleting an element can not find an index key corresponding to the input argument, then an error occurs as follows.

```
gSQL> DECLARE
  TYPE rec IS TABLE OF T1%ROWTYPE INDEX BY VARCHAR(10);
  V1 rec;
BEGIN
  V1('person1').C1 := 'seoul';
  V1('person1').C2 := '12';
  -- Call delete procedure
  V1.delete('person2');
END;
/
ERR-HY000(17045): no data found :
  V1.delete('person2');
*
ERROR at line 9:
Anonymous PL block executed.
```

## 22.5 SYS\_REFCURSOR

SYS\_REFCURSOR is a predefined type for a cursor variable, and it is used to declare a cursor variable.

It is used to declare a cursor variable in the following form.

```
cursor_variable_name SYS_REFCURSOR;
```

Cursor variable can be used together with OPEN FOR, FETCH, CLOSE statement as follows.

```
DECLARE
  v1 VARCHAR(20);
  v2 VARCHAR(20);
  cv1 SYS_REFCURSOR;
  cv2 SYS_REFCURSOR;
BEGIN
  OPEN cv1 FOR SELECT * FROM T1;
  cv2 := cv1;
  FETCH cv2 INTO V1, V2;
  DBMS_OUTPUT.PUT_LINE('V1 = ' || V1 || ' , V2 = ' || V2);
END;
/
V1 = Seoul , V2 = 24
Anonymous PL block executed.
```

- The variable declared by using SYS\_REFCURSOR is used as follows.
  - It is possible to assign each cursor variable among cursor variables. An existing open cursor of the cursor variable which is on the right of the assign can not be used any more.
  - An explicit cursor can not be assigned to a cursor variable.
  - A variable of a different data type can not be assigned to a cursor variable.
  - A nested function/procedure and schema-level function/procedure can be used as a parameter.

For more information, refer to **CURSOR VARIABLES**, **Cursor Variable Declaration**, **OPEN FOR Statement**.



**23.**

---

## **PSM Control Statements**

## 23.1 Assignment

It inserts the calculation value of the right expression into the left variable by using assignment operators (':=').

### Assignment Target

An assignment target is on the left side of the assignment operator, and the following items may exist on it.

- Variables (Including an argument of a procedure or a function except for IN type)
- Bind parameter such as '?' or ':V1' (It can be used only in an anonymous PL block.)

### Assigning Expression

An expression available on PSM is on the right side of the assignment operator. Expressions available on a PSM expression is as follows.

- Constant
- All operators, built-in functions or pseudo columns provided by GOLDILOCKS SQL
- Bind parameter bound to IN or IN OUT type (It can be used only in an anonymous PL block.)
- PSM variable
- PSM nested function
- Schema-level function

The following is an example of assignment statement per each type.

```
CREATE OR REPLACE FUNCTION ADD_TEN( A1 INTEGER )  
RETURN INTEGER  
IS  
BEGIN  
    RETURN A1 + 10;  
END;  
/  
COMMIT;  
DECLARE  
    FUNCTION ADD_ONE( A1 INTEGER )
```



```

RETURN INTEGER
IS
BEGIN
    RETURN A1 + 1;
END;
V_NUM INTEGER;
V_STR VARCHAR(10);
BEGIN
    V_NUM := 10;           ❶ Numeric literal
    V_STR := 'ABC';       ❷ String literal
    :V_PARAM := V_STR || 'DEF';  ❸ PSM variable, SQL operator
    V_NUM := ADD_ONE( 100 ) + ADD_TEN( 1000 );
                                ❹ Nested function, Schema-level function
END;
/

```

The following expressions can not be used in an PSM expression.

- Column of a table, view or the corresponding object
- SQL objects such as an index, a sequence or a synonym
- Subquery
- Nested procedure
- Schema-level procedure

The following is an example of an error due to a wrong expression.

```

gSQL> CREATE SEQUENCE SEQ1;
Sequence created.
gSQL> COMMIT;
Commit complete.
gSQL> DECLARE
    V1 INTEGER;
BEGIN
    V1 := SEQ1.NEXTVAL;
END;
/
ERR-HY000(17032): PSM compilation error :
(1) at (4:9): ERR-42000(16074): sequence number not allowed here

```

To assign an object value of a type which is not available in an PSM expression, use SELECT INTO statement as follows.

```
gSQL> DECLARE
  V1 INTEGER;
BEGIN
  SELECT SEQ1.NEXTVAL INTO V1 FROM DUAL;
END;
/
Anonymous PL block executed.
```

## Assignment Compatibility

Even though the statement can use an expression of an assignment statement, it may succeed or fail depending on a target type and the final result type of an expression. The available expression types according to a target type is as follows.

**Table 23-1** Assignment compatibility

Target type	Final result type of an expression
Scalar type <ul style="list-style-type: none"> <li>• Scalar type variable</li> <li>• A specific field of a record type variable</li> <li>• Scalar element of a collection variable with a key value</li> </ul>	It is allowed only when it is a scalar type with a value convertible to a target type.
Attribute record type (%ROWTYPE)	It is allowed only when the number of fields are same and each field value is convertible to the field of the corresponding order of a target.
User defined record type	Only the exactly same type is allowed.
Collection type <ul style="list-style-type: none"> <li>• Collection type variable whose key value is not specified</li> </ul>	Only the exactly same type is allowed.

Even though the internal structures of user defined record type variables are same, an error occurs if the type names are different.

```
gSQL> DECLARE
  TYPE MY_REC1 IS RECORD ( F1 INTEGER := 1, F2 VARCHAR(10) := 'AAA' );
  TYPE MY_REC2 IS RECORD ( F1 INTEGER := 1, F2 VARCHAR(10) := 'AAA' );
  V1 MY_REC1;
  V2 MY_REC2;
BEGIN
  V2 := V1;
END;
```

```
/  
ERR-HY000(17032): PSM compilation error :  
(1) at (7:9): ERR-HY000(17007): invalid expression
```

Moreover, if a target is an argument variable defined with IN attribute or is a bind parameter bound with IN attribute, an error occurs.

```
gSQL> DECLARE  
  FUNCTION ADD_ONE( A1 IN INTEGER )  
  RETURN INTEGER  
  IS  
  BEGIN  
    A1 := A1 + 1;  
    RETURN A1;  
  END;  
  V1 INTEGER;  
BEGIN  
  V1 := ADD_ONE( 10 );  
END;  
/  
ERR-HY000(17032): PSM compilation error :  
(1) at (6:5): ERR-HY000(17024): (A1) cannot be used as assignment target
```

Assignment compatibility rules are applied same even when assigning the value of an actual parameter to a formal parameter variable while calling a function or a procedure.

## 23.2 PL Block

A PL block is a basic unit which configures PSM. A PL block can be nested again in another PL block. Items declared within a PL block can be referenced only within the range of its own block (including subordinate blocks)

### PL Block Configuration

A single PL block is divided into the following three parts.  
For more information, refer to **Block (BEGIN .. END)**.

```
[DECLARE
  ① Declarative part]
BEGIN
  ② Statements
[EXCEPTION
  ③ Handlers]
END;
```

### Declarative Part

A declarative part is an area in which a local item to be used within a PL block is declared. If an item such as a local variable to be declared does not exist, then a declarative part is not defined, but it starts from an executable part.

Local items to be declared in a declarative part is as follows.

- Variable (Refer to **PSM DataTypes**.)
- User defined type
- Cursor
- Nested function or a procedure (Subprogram)
- User defined exception

All names of items declared in a single PL block should be unique regardless of their types. For example, a cursor whose name is as same as a name of a variable can not be declared.

```
gSQL> DECLARE
  C1 INTEGER;
  CURSOR C1 IS SELECT * FROM DUAL;
```

```

BEGIN
  OPEN C1;
  FETCH C1 INTO C1;
  CLOSE C1;
END;
/
ERR-HY000(17032): PSM compilation error :
(1) at (3:10): ERR-HY000(17027): duplicated identifier
(2) at (5:8): ERR-HY000(17031): mismatch identifier type
(3) at (6:9): ERR-HY000(17031): mismatch identifier type
(4) at (7:9): ERR-HY000(17031): mismatch identifier type

```

However, an item in a subordinate PL block whose name is as same as an item in a superordinate PL block can be declared. In this case, that name means the item found first when exploring from the current location toward the superordinate block.

```

gSQL> <<PP>>
DECLARE ① Parent scope begin
  V1 VARCHAR(10) := 'AAA';
BEGIN
  <<CC>>
  DECLARE ② Child scope begin
    V1 INTEGER := 99;
  BEGIN
    DBMS_OUTPUT.PUT_LINE( 'PP.V1 = ' || PP.V1 );
    DBMS_OUTPUT.PUT_LINE( 'CC.V1 = ' || CC.V1 );
    DBMS_OUTPUT.PUT_LINE( 'V1 = ' || V1 );
  END; ③ Child scope end
END; ④ Parent scope end
/
PP.V1 = AAA
CC.V1 = 99
V1 = 99
Anonymous PL block executed.

```

## Executable Part

In an executable part, a declared items are manipulated and included statements are performed. Statements available in an executable parts are as follows.

- Control Statements (Refer to **PSM Control Statements**.)

- Cursor Statements (Refer to **PSM Cursor Statements**.)
- SQL Statements (static/ dynamic) (Refer to **Using SQLs In PSM**.)

## Exception Handling Part

It defines handlers which handles multiple exceptions occurring during the execution.

If an exception occurs during executing several statements in an executable part, then it explores from the location of that PL block to the superordinate PL block to find out whether a handler is registered to handle the exception. If there is the handler, then it performs the contents of that handler, then initializes the situation at an exceptional situation.

```
DECLARE
  V1 INTEGER;
BEGIN
  SELECT C1 INTO V1 FROM T1 WHERE C1 = 100;
EXCEPTION
  WHEN NO_DATA_FOUND THEN
    DBMS_OUTPUT.PUT_LINE('SQL%ISOPEN = ' || SQL%ISOPEN);
    DBMS_OUTPUT.PUT_LINE('SQL%FOUND = ' || SQL%FOUND);
    DBMS_OUTPUT.PUT_LINE('SQL%NOTFOUND = ' || SQL%NOTFOUND);
    DBMS_OUTPUT.PUT_LINE('SQL%ROWCOUNT = ' || SQL%ROWCOUNT);
END;
/
```

If an appropriate handler is not found even after exploring to the top-level PL block, then the occurred exception is returned to a caller, and it is terminated.

```
gSQL> DECLARE
  v1 INTEGER;
BEGIN
  v1 := 1/ 0;
END;
/
ERR-HY000(17007): invalid expression :
  v1 := 1/ 0;
      *
ERROR at line 4:
ERR-22012(12122): divisor is equal to zero
```

For more information about declaration of user defined exception, built-in handler types or installing a handler, refer to **Error Handling**.

## 23.3 NULL Statement

It is used to specify a statement which does not have any role in PSM such as no-op.  
For more information, refer to **NULL Statement**.

```
DECLARE
  V1 INTEGER := 1;
BEGIN
  IF V1 < 10 THEN
    V1 := V1 + 1;
  ELSE
    NULL; -- do nothing
  END IF;
END;
/
```

## 23.4 Testing Conditions

Conditional branch statements perform statements according to true/false of the given condition. GOLDI LOCKS PSM provides two conditional branch statements, which are IF and CASE.

### IF

IF statement performs statements which are true among conditions of the given expression. Conditions of an expression can be specified next to IF and ELSIF. If the condition of an expression is true when checking conditions in an order specified when performing, then it performs the statements below THEN clause. If all IF conditions and ELSIF conditions are false, and ELSE clause is specified, then it performs the statements below ELSE clause.

IF statement always ends with END IF keyword.

For more information, refer to **IF Statement**.

```
DECLARE
V1 INTEGER := 1;
BEGIN
  -- IF COND
  IF V1 > 0 THEN
    DBMS_OUTPUT.PUT_LINE( 'IF COND' );
  ELSIF V1 = 0 THEN
    DBMS_OUTPUT.PUT_LINE( 'ELSIF COND' );
  ELSE
    DBMS_OUTPUT.PUT_LINE( 'ELSE COND' );
  END IF;
  -- ELSIF COND
  IF V1 = 0 THEN
    DBMS_OUTPUT.PUT_LINE( 'IF COND' );
  ELSIF V1 > 0 THEN
    DBMS_OUTPUT.PUT_LINE( 'ELSIF COND' );
  ELSE
    DBMS_OUTPUT.PUT_LINE( 'ELSE COND' );
  END IF;
  -- ELSE COND
  IF V1 = 0 THEN
    DBMS_OUTPUT.PUT_LINE( 'IF COND' );
```



```

ELSIF V1 < 0 THEN
    DBMS_OUTPUT.PUT_LINE( 'ELSIF COND' );
ELSE
    DBMS_OUTPUT.PUT_LINE( 'ELSE COND' );
END IF;
END;
/

```

ELSIF clause and ELSE clause are optional, so it may or may not be specified.

When ELSE statement is not specified and any conditions of IF or ELSIF is not true, then it does not perform any statement, but proceeds to the next statement without causing any exception.

## CASE

CASE statement selects a single array among arrays of multiple statements such as IF statement, then performs it. CASE statement ends with END CASE keyword, and ELSE clause is optional so it may or may not be specified.

If WHEN clause with an appropriate condition can not be found and ELSE clause is specified, then it arrays statements below ELSE clause. If an appropriate condition does not exist nor is ELSE clause specified, then CASE\_NOT\_FOUND exception occurs.

For more information, refer to **CASE Statement**.

WHEN clauses in CASE is evaluated in an specified order, and if an appropriate WHEN clause is found and statements of that WHEN clause are arrayed, then all WHEN clauses after that are ignored.

There are two kinds of CASE statements as follows.

- Simple CASE statement
- Searched CASE statement

### Simple CASE Statement

A simple CASE statement arrays statements owned by WHEN clause which has the same value as a select or expression among expressions specified next to WHEN clause by using a selector expression specified next to CASE keyword. Then it ends.

```

DECLARE
V1 VARCHAR(1) := '2';
BEGIN

```

```

CASE V1 WHEN '0' THEN DBMS_OUTPUT.PUT_LINE ('Result = 0');
        WHEN '1' THEN DBMS_OUTPUT.PUT_LINE ('Result = 1');
        WHEN '2' THEN DBMS_OUTPUT.PUT_LINE ('Result = 2');
        ELSE DBMS_OUTPUT.PUT_LINE ('Result = Other');
END CASE;
END;
/

```

## Searched CASE Statement

A searched CASE statement does not have a selector expression, instead a conditional expression which is evaluated as boolean type per each WHEN clause is specified. When it is executed, it arrays statements owned by the first WHEN clause which is TRUE by evaluating expressions of each WHEN clause. Then it ends.

```

DECLARE
V1 VARCHAR(1) := '2';
BEGIN
CASE WHEN V1 = 0 THEN DBMS_OUTPUT.PUT_LINE ('Result = 0');
        WHEN V1 = 1 THEN DBMS_OUTPUT.PUT_LINE ('Result = 1');
        WHEN V1 = 2 THEN DBMS_OUTPUT.PUT_LINE ('Result = 2');
        ELSE DBMS_OUTPUT.PUT_LINE ('Result = OTHER');
END CASE;
END;
/

```

## 23.5 Iterative Control

Iterative control statements performs a series of statements several times. GOLDILOCKS PSM provides the following iterative control statements.

- Basic loop
- FOR loop
- WHILE loop

### Basic Loop

A basic loop statement encloses a series of statements which are to be performed several times with LOOP and END LOOP keywords. This statement indefinitely performs the inner statements, and it can escape out of the loop by using EXIT or GOTO statements which are sequential control statements.

For more information, refer to **Basic LOOP Statement**.

The following is an example of escaping from a basic loop which has the closest scope from that location by using EXIT WHEN statement.

For more information, refer to **EXIT Statement**.

```
gSQL> DECLARE
  V1 INTEGER := 1;
BEGIN
  LOOP
    DBMS_OUTPUT.PUT_LINE( 'V1 = ' || V1 );
    V1 := V1 + 1;
    EXIT WHEN V1 > 10;  -- Escape Condition
  END LOOP;
END;
/
V1 = 1
V1 = 2
V1 = 3
V1 = 4
V1 = 5
V1 = 6
V1 = 7
V1 = 8
V1 = 9
```

```
V1 = 10
```

Anonymous PL block executed.

To escape out of a specific loop when multiple loops are nested, specify a label in front of that loop and specify that label as a target label in EXIT statement.

```
gSQL> DECLARE
  V1 INTEGER := 1;
BEGIN
  <<OUTER_LOOP>>
  LOOP
    <<INNER_LOOP>>
    LOOP
      DBMS_OUTPUT.PUT_LINE( 'V1 = ' || V1 );
      V1 := V1 + 1;
      EXIT OUTER_LOOP WHEN V1 > 5; -- Escape Condition
    END LOOP INNER_LOOP;
    DBMS_OUTPUT.PUT_LINE( 'END OF INNER LOOP' );
    V1 := V1 + 5;
  END LOOP OUTER_LOOP;
  DBMS_OUTPUT.PUT_LINE( 'END OF OUTER LOOP' );
END;
/
V1 = 1
V1 = 2
V1 = 3
V1 = 4
V1 = 5
END OF OUTER LOOP
```

Anonymous PL block executed.

## FOR Loop

FOR loop statement repeatedly performs a series of statements as many times as the number of integers of the given scope.

For more information, refer to **FOR LOOP Statement**.

A user creates an index variable with the name specified next to FOR keyword.

Then, it sets the lower bound specified on the left side of a scope operator (..) which is next to IN keyword as an initial value of the index variable. Then, it performs a series of statements by increasing the index

variable by 1 per each loop until it becomes as same as the higher bound specified on the right side of a scope operator (..).

```
BEGIN
  FOR I IN 0 .. 2 LOOP
    DBMS_OUTPUT.PUT_LINE( 'I = ' || I );
  END LOOP;
END;
/
I = 0
I = 1
I = 2
Anonymous PL block executed.
```

When REVERSE keyword is specified in front of the scope, it sets the higher bound specified on the right side of a scope operator (..) as an initial value of the index variable. Then, it performs a series of statements by decreasing the index variable by 1 per each loop until it becomes as same as the lower bound specified on the left side of a scope operator (..).

```
BEGIN
  FOR I IN REVERSE 0 .. 2 LOOP
    DBMS_OUTPUT.PUT_LINE( 'I = ' || I );
  END LOOP;
END;
/
I = 2
I = 1
I = 0
Anonymous PL block executed.
```

## WHILE Loop

WHILE loop statement repeatedly performs a series of statements while the given condition is TRUE. For more information, refer to **WHILE LOOP Statement**.

```
DECLARE
V1 integer := 0;
BEGIN
  WHILE V1 < 10 LOOP
    DBMS_OUTPUT.PUT_LINE( 'V1 = ' || V1 );
```

```
V1 := V1 + 1;  
END LOOP;  
END;  
/
```

WHILE loop checks given conditions before performing statements of a body so if the condition is FALSE from the beginning, then it may not perform statements of a body at all.

## 23.6 Sequential Control

Sequential control statements move on which a program is performed from the current performing location to another location.

GOLDILOCKS PSM provides the following three sequential control statements.

- GOTO
- CONTINUE
- EXIT

### GOTO

GOTO statement moves the performing location to the statement in which the given label is. It can be specified in front of any statement which is executable within PSM of a label. A target label to which GOTO moves can exist before and after the GOTO statement. However, only a visible statement can perform GOTO.

For more information, refer to **GOTO Statement**.

Conditions for a visible statement is as follows.

- Sibling statements located before and after the current performing location
- A superordinate statement of the current location, and sibling statements located before and after the superordinate statement

The following is an example of moving a performing location to a sibling statement of the current location.

```
gSQL> BEGIN
  <<PARENT_PREV>>
  DBMS_OUTPUT.PUT_LINE('PARENT PREV');
  <<PARENT>>
  IF 1 > 0 THEN
    <<SIBLING_PREV>>
    DBMS_OUTPUT.PUT_LINE('SIBLING PREV');
    <<CURRENT_POSITION>>
    GOTO SIBLING_NEXT;
    DBMS_OUTPUT.PUT_LINE('SIBLINGS');
    DBMS_OUTPUT.PUT_LINE('SIBLINGS');
    <<SIBLING_NEXT>>
```

```

    DBMS_OUTPUT.PUT_LINE('SIBLING NEXT');
ELSE
    <<NON_SIBLING>>
    DBMS_OUTPUT.PUT_LINE('NON SIBLING');
END IF;
<<PARENT_NEXT>>
DBMS_OUTPUT.PUT_LINE('PARENT NEXT');
END;
/
PARENT PREV
SIBLING PREV
SIBLING NEXT
PARENT NEXT
Anonymous PL block executed.

```

The following is an example of moving a performing location to a superordinate statement of a current location.

```

gSQL> BEGIN
    <<PARENT_PREV>>
    DBMS_OUTPUT.PUT_LINE('PARENT PREV');
    <<PARENT>>
    IF 1 > 0 THEN
        <<SIBLING_PREV>>
        DBMS_OUTPUT.PUT_LINE('SIBLING PREV');
        <<CURRENT_POSITION>>
        GOTO PARENT_NEXT;
        DBMS_OUTPUT.PUT_LINE('SIBLINGS');
        DBMS_OUTPUT.PUT_LINE('SIBLINGS');
        <<SIBLING_NEXT>>
        DBMS_OUTPUT.PUT_LINE('SIBLING NEXT');
    ELSE
        <<NON_SIBLING>>
        DBMS_OUTPUT.PUT_LINE('NON SIBLING');
    END IF;
    <<PARENT_NEXT>>
    DBMS_OUTPUT.PUT_LINE('PARENT NEXT');
END;
/
PARENT PREV
SIBLING PREV

```



## PARENT NEXT

Anonymous PL block executed.

The following is an example of moving a performing location to a statement which is not a sibling, so an error occurs.

```
gSQL> BEGIN
  <<PARENT_PREV>>
  DBMS_OUTPUT.PUT_LINE('PARENT PREV');
  <<PARENT>>
  IF 1 > 0 THEN
    <<SIBLING_PREV>>
    DBMS_OUTPUT.PUT_LINE('SIBLING PREV');
    <<CURRENT_POSITION>>
    GOTO NON_SIBLING;
    DBMS_OUTPUT.PUT_LINE('SIBLINGS');
    DBMS_OUTPUT.PUT_LINE('SIBLINGS');
    <<SIBLING_NEXT>>
    DBMS_OUTPUT.PUT_LINE('SIBLING NEXT');
  ELSE
    <<NON_SIBLING>>
    DBMS_OUTPUT.PUT_LINE('NON SIBLING');
  END IF;
  <<PARENT_NEXT>>
  DBMS_OUTPUT.PUT_LINE('PARENT NEXT');
END;
/
ERR-HY000(17032): PSM compilation error :
(1) at (12:10): ERR-HY000(17010): can not find label name
```

Likewise, when moving a performing location to a statement which is not a superordinate sibling of the current statement, then an error occurs.

GOTO is a good tool to make a PSM program logic flexible. However, like in other languages, if it is used too much, then it may downgrade the readability, so maintenance becomes difficult. Therefore, it is recommended to use loop statements such as FOR or WHILE for an ordinary logics, and use GOTO only when it is necessary.

## CONTINUE

CONTINUE statement terminates the current iteration and starts the next iteration within a loop statement such as FOR or WHILE.

For more information, refer to **CONTINUE Statement**.

```

DECLARE
  V1 INTEGER := 1;
BEGIN
  <<AAA>>
  WHILE V1 <= 10 LOOP
    DBMS_OUTPUT.PUT_LINE( 'V1 = ' || V1 );
    V1 := V1 + 1;
    IF V1 <= 2 THEN
      DBMS_OUTPUT.PUT_LINE( 'CONTINUE' );
      CONTINUE;
    ELSE
      EXIT;
    END IF;
    DBMS_OUTPUT.PUT_LINE( 'END-OF-WHILE' );
  END LOOP AAA;
END;
/

```

If a target label is specified, it starts the next iteration of a loop which has the corresponding label. If it is not specified, it starts the next iteration of the closest (inner) loop.

```

DECLARE
  V1 INTEGER := 1;
BEGIN
  <<AAA>>
  FOR I IN 0..5 LOOP
    <<BBB>>
    WHILE V1 <= 10 LOOP
      DBMS_OUTPUT.PUT_LINE( 'I = ' || I );
      DBMS_OUTPUT.PUT_LINE( 'V1 = ' || V1 );
      V1 := V1 + 1;
      IF V1 <= 2 THEN
        CONTINUE BBB;
      ELSE

```

```

        EXIT AAA;
    END IF;
END LOOP BBB;
END LOOP AAA;
END;
/

```

WHEN clause can be optionally specified in CONTINUE statement. In this case, it terminates the current iteration and starts the next iteration, only when an expression next to WHEN clause is TRUE.

```

DECLARE
    V1 INTEGER :=0 ;
BEGIN
    LOOP
        V1 := V1 + 1;
        CONTINUE WHEN V1 < 5;
        EXIT;
    END LOOP;
END;
/

```

## EXIT

EXIT statement escapes the current loop and performs the next statement. For more information, refer to **EXIT Statement**.

```

DECLARE
    V1 INTEGER := 1;
BEGIN
    WHILE V1 <= 10 LOOP
        DBMS_OUTPUT.PUT_LINE( 'V1 = ' || V1 );
        IF V1 > 5 THEN
            EXIT;
        END IF;
        V1 := V1 + 1;
    END LOOP;
END;
/

```

If a target loop is specified, then it escapes a loop which has the corresponding label.

```

DECLARE
  V1 INTEGER := 1;
BEGIN
  <<AAA>>
  FOR I IN 0..5 LOOP
    <<BBB>>
    WHILE V1 <= 10 LOOP
      DBMS_OUTPUT.PUT_LINE( 'V1 = ' || V1 );
      IF V1 >= 5 THEN
        EXIT AAA;
      END IF;
      V1 := V1 + 1;
    END LOOP BBB;
  END LOOP AAA;
END;
/

```

WHEN clause can be optionally specified in EXIT statement, like as in CONTINUE statement. In this case, it performs EXIT, only when the given condition is TRUE.

```

DECLARE
  V1 INTEGER := 1;
BEGIN
  <<AAA>>
  FOR I IN 0..5 LOOP
    <<BBB>>
    WHILE V1 <= 10 LOOP
      DBMS_OUTPUT.PUT_LINE( 'V1 = ' || V1 );
      EXIT AAA WHEN V1 >= 5;
      V1 := V1 + 1;
    END LOOP BBB;
  END LOOP AAA;
END;
/

```

## 23.7 Error Handling

Errors in PSM are as follows depending on the point of time when it occurs.

- Errors at compile time
- Errors at run time

### Errors at Compile Time

A compile error outputs an error which occurs during the validation of PSM statement specified in a procedure/function.

A syntax error outputs only the location of the first found syntax error as follows, so a user should compile it again to find out if there are any additional errors.

```
CREATE OR REPLACE PROCEDURE PROC1
IS
BEGIN
  V1 = 1;
  V2 = 1;
END;
/
ERR-42000(40000): syntax error:
  V1 = 1;
.....^
Error at line 4
```

If a syntax error does not exist, then GOLDILOCKS performs a validation while compiling a PSM statement and the errors occurred in this case are output as follows.

```
CREATE OR REPLACE PROCEDURE PROC1
IS
BEGIN
  V1 := 1;
  V2 := 2;
END;
/
ERR-01000(16409): Warning: Routine definition has compilation errors
ERR-HY000(17032): PSM compilation error :
```

```
(1) at (4:3): ERR-HY000(17006): unknown variable or column name (V1)
(2) at (5:3): ERR-HY000(17006): unknown variable or column name (V2)
Procedure created.
```

Compile errors output the information of errors within the size which is allowed in the error output buffer of GOLDILOCKS. Therefore, some errors may not be output. If so, it is output in the following form to notify that there are errors which are not output.

```
CREATE OR REPLACE PROCEDURE PROC1
IS
BEGIN
V1 := 1;
V2 := 2;
V3 := 2;
V4 := 2;
V5 := 2;
V6 := 2;
V7 := 2;
V8 := 2;
V10 := 2;
END;
/
ERR-01000(16409): Warning: Routine definition has compilation errors
ERR-HY000(17032): PSM compilation error :
(1) at (4:3): ERR-HY000(17006): unknown variable or column name (V1)
(2) at (5:3): ERR-HY000(17006): unknown variable or column name (V2)
(3) at (6:3): ERR-HY000(17006): unknown variable or column name (V3)
(4) at (7:3): ERR-HY000(17006): unknown variable or column name (V4)
(5) at (8:3): ERR-HY000(17006): unknown variable or column name (V5)
(6) at (9:3): ERR-HY000(17006): unknown variable or column name (V6)
(7) at (10:3): ERR-HY000(17006): unknown variable or column name (V7)
2 more errors...
```

An error message is output in the following form.

```
(Index) at (Line_Number : Column_Position): ERR-SQLState( Internal_ErrorCode):
Detail_Error_Message
```

- Index
  - It is a sequence of an error occurrence.
- Line\_Number
  - It is a location of a line of source in which an error occurred.

- Column\_Position
  - It is a location of a column of a source in which an error occurred.
- ERR-SQLState
  - It is a standard SQLState.
- Internal\_ErrorCode
  - It is an internal error code.
- Detail\_Error\_Message
  - It is details of an error message.

## Errors at Run-time

An error may occur in a PSM statement for various reasons even when PSM is normally executed. In this case, GOLDILOCKS provides an exception handling to help a user to control the error.

The following is an example of an error occurrence at the time of execution. If an error occurs when executing GOLDILOCKS PMS, then it outputs a location of an error, a PSM error and an internal error together. In other words, one or more errors may occur, so all errors should be retrieved from the database through a function such as SQLGetDiagRec if a user wants to find out the exact error message during the development process such as ODBC.

```

DECLARE
  V1 INTEGER;
BEGIN
  V1 := 1 / 0;
END;
/
ERR-HY000(17007): invalid expression :
  V1 := 1 / 0;
      *
ERROR at line 4:
ERR-22012(12122): divisor is equal to zero

```

If an error occurs at the time of operation, PSM immediately stops the operation and notifies it to a user. However, if a user wants to directly control these errors and keep the program running, the user should perform the exception handling.

The following is an example of definition to run the user program without interruption by performing the exception handling on the location of an error.

```

DECLARE
  V1 INTEGER;
BEGIN
  BEGIN
    V1 := 1 / 0;
  EXCEPTION WHEN OTHERS
    THEN DBMS_OUTPUT.PUT_LINE('SQLCODE = ' || SQLCODE);
    DBMS_OUTPUT.PUT_LINE('SQLERRM = ' || SQLERRM);
  END;

  DBMS_OUTPUT.PUT_LINE('next code');
END;
/
SQLCODE = -12122
SQLERRM = [SUNJESOFT][PSM][GOLDILOCKS]divisor is equal to zero
next code
Anonymous PL block executed.

```

For more information, refer to [EXCEPTION Handling](#), [SQLCODE Function](#), [SQLERRM Function](#).

## Cursor Attributes

Cursor attributes are attributes (variables) which are provided to display the cursor status specified by a user or to display the inside of the database, while processing PSM.

- Cursors are specified as follows.
  - Implicit cursor
    - It is a cursor which is OPEN/ FETCH/ CLOSE inside of the database when it is required.
  - Explicit cursor
    - It is a cursor which OPEN/ FETCH /CLOSE after when a user explicitly perform declaration/ definition.

## Implicit Cursor Attributes

Implicit cursor attributes in PSM is used to find out the processing status of a SQL statement which was approximately performed. Each value of attributes can be used in expressions such as a conditional expression, so a user can control it such as branching logics of a program through that value.

For more information about attributes, refer to the following table.



**Table 23-2** Implicit cursor attributes

Attribute name	Return type	Description
ISOPEN	BOOLEAN	It is always FALSE because it is internally closed.
FOUND	BOOLEAN	If the data is returned by the previous statement, then it is TRUE. Otherwise, it is FALSE.
NOTFOUND	BOOLEAN	It is the opposite value of FOUND.
ROWCOUNT	INTEGER	It is the number of rows affected by the previous statement.

The syntax is used in the following form.

```
SQL%Attribute_name
Attribute_name := ISOPEN | FOUND | NOTFOUND | ROWCOUNT
```

Each attribute can be viewed as the following example.

```
gSQL> CREATE TABLE T1
(
  C1 VARCHAR(20),
  C2 VARCHAR(20)
);
Table created.
gSQL> INSERT INTO T1 VALUES ('Seoul', '24');
1 row created.
gSQL> INSERT INTO T1 VALUES ('Pusan', '44');
1 row created.
gSQL> BEGIN
  UPDATE T1 SET C2 = C2 + 1;

  DBMS_OUTPUT.PUT_LINE('ISOPEN   = ' || SQL%ISOPEN );
  DBMS_OUTPUT.PUT_LINE('FOUND    = ' || SQL%FOUND  );
  DBMS_OUTPUT.PUT_LINE('NOTFOUND = ' || SQL%NOTFOUND );
  DBMS_OUTPUT.PUT_LINE('ROWCOUNT = ' || SQL%ROWCOUNT );
END;
/
ISOPEN   = FALSE
FOUND    = TRUE
NOTFOUND = FALSE
ROWCOUNT = 2
Anonymous PL block executed.
```

## Explicit Cursor Attributes

Explicit cursor attributes is used to enquire the status of an explicit cursor. For more information about attributes, refer to the following table.

**Table 23-3** Cursor attributes

Attributes	Return type	Description
%ISOPEN	BOOLEAN	It is TRUE only when a cursor is normally open. Otherwise, it is FALSE.
%FOUND	BOOLEAN	It is NULL before FETCH, and it is TRUE when FETCH is normally performed. It is FALSE when data does not exist, and it is NULL after CLOSE.
%NOTFOUND	BOOLEAN	It is the opposite value of %FOUND.
%ROWCOUNT	INTEGER	It is NULL before OPEN, and it is 0 when it is normally OPEN. It increases by 1 whenever FETCH succeeds.

It is used as follows within PSM.

```
Cursor_Name % Attribute_name
Attribute_name := ISOPEN
                | FOUND
                | NOTFOUND
                | ROWCOUNT
```

The following is an example of using an explicit cursor attribute.

```
gSQL> CREATE TABLE T1
(
  C1 VARCHAR(20),
  C2 VARCHAR(20)
);
Table created.
gSQL> INSERT INTO T1 VALUES ('Seoul', '24');
1 row created.
gSQL> INSERT INTO T1 VALUES ('Pusan', '44');
1 row created.
gSQL> DECLARE
  CURSOR C1 IS SELECT * FROM T1;
  v1 c1%ROWTYPE;
BEGIN
```

- Check if the cursor is open through ISOPEN.

```

IF C1%ISOPEN = FALSE
  THEN
    OPEN C1;
  END IF;
  LOOP
    FETCH C1 INTO v1;

```

- Check if there is any more data through NOTFOUND.

```
EXIT WHEN C1%NOTFOUND;
```

- Find out the number of fetched rows through ROWCOUNT.

```

DBMS_OUTPUT.PUT_LINE('COUNT = ' || C1%ROWCOUNT );
  END LOOP;
  CLOSE C1;

END;
/
COUNT = 1
COUNT = 2
Anonymous PL block executed.

```

## EXCEPTION Handling

Exceptions within PSM is a definition of various errors occurred while a user is executing PSM. If an error occurs at the time of operation, PSM immediately stops the operation and returns an error to a user. EXCEPTION handling is a function provided to a user to control EXCEPTION situation and keep the program running without interruption.

### Exception Handler

An error situation can be controlled through an exception handler defined in PSM BLOCK as follows.

```

DECLARE
  V1 INTEGER;
BEGIN
  BEGIN
    V1 := 1 / 0;

```

- Exception handler

```

EXCEPTION WHEN OTHERS
    THEN DBMS_OUTPUT.PUT_LINE('SQLCODE = ' || SQLCODE);
         DBMS_OUTPUT.PUT_LINE('SQLERRM = ' || SQLERRM);

END;

DBMS_OUTPUT.PUT_LINE('next code');
END;
/
SQLCODE = -12122
SQLERRM = [SUNJESOFT][PSM][GOLDILOCKS]divisor is equal to zero
next code

```

In the example above, the program is stopped by *divide by zero* at the time of execution. However, if an error occurred by an exception handler, then only the corresponding BLOCK stops, but the processing continues from the next location.

An exception handler is specified as follows.

```

BEGIN
EXCEPTION WHEN exception_name, [exception_name, ...] THEN pl_statements;
           [WHEN exception_name, [exception_name, ...] THEN pl_statements;
END

```

- Features of an exception handler are as follows.
  - A single exception handler is specified in BLOCK.
  - One or more Exception\_Name can be specified and its operation can be defined within an exception handler.
  - Exception\_name within an exception handler should not be duplicate.
  - It is operated only for an error within PL BLOCK SCOPE in which an exception handler is specified.
  - OTHERS indicating all exceptional situations should be unique, and should be specified at last.
  - If an exception handler is normally completed, the previous errors are cleared. Therefore, a user should store them in a separate PSM variable if in need.

An exception in GOLDILOCKS has the following properties.

**Table 23-4** EXCEPTION types

Type	Definer	Error code	Name	Raise implicitly	Raise explicitly
Predefined	Database	O	O	O	Optionally
User defined	User	User-defined	User defined	X	O



For more information about a predefined exception or a user defined exception provided by GO LDILOCKS, refer to **Exception Declaration**.

## Propagating Exception

If an appropriate exception handler does not exist in the current BLOCK when an exception occurs, then it is propagated to an exception handler of the superordinate BLOCK until the exception is processed.

If an error occurred on LINE\_1 in the following code, the result varies upon whether an exception handler operates.

```
BEGIN
  ...
  BEGIN
    LINE_1
    EXCEPTION HANDLER_1
  END;
  LINE_2
  EXCEPTION HANDLER_2
END;
/
```

- When it is processed in EXCEPTION\_HANDLER\_1
  - If the handler operation is normally completed, then it is performed from LINE\_2.
- When an appropriate handler does not exist in EXCEPTION\_HANDLER\_1
  - It can not perform LINE\_2, and the currently occurred EXCEPTION is propagated to EXCEPTION\_HANDLER\_2.
    - When an appropriate handler exists in EXCEPTION\_HANDLER\_2, if a handler operation is normally completed, then the program ends.
    - If a handler does not exist in EXCEPTION\_HANDLER\_2, the program stops and the currently occurred error is returned to a user.



If an error occurred in an exception handler which was processing an exception, then the error code is propagated to a superordinate BLOCK.

```
DECLARE
  V1 INTEGER;
  E1 EXCEPTION;
  E2 EXCEPTION;
BEGIN
```

```

BEGIN
  RAISE E1;
EXCEPTION WHEN E1 THEN V1 := 1 / 0; ❶ A new error occurs.
END;
EXCEPTION WHEN E1
  THEN DBMS_OUTPUT.PUT_LINE('User Exception');
  WHEN ZERO_DIVIDE
  THEN DBMS_OUTPUT.PUT_LINE('Zero divide');
END;
/
Zero divide
Anonymous PL block executed.

```

## User Defined Exception

A user defined exception is an exception used by setting an exception name and an error-code by a user except for a predefined. User defined exception can not implicitly occur, but a user should execute it by explicitly using a RAISE statement.

The following is an example of causing an exception by using a RAISE statement.

```

DECLARE
  V1  INTEGER;
  high EXCEPTION;
  low  EXCEPTION;
BEGIN
  BEGIN
    V1 := 10;
    IF V1 > 10
    THEN
      RAISE high;
    ELSE
      RAISE low;
    END IF;
  EXCEPTION WHEN high
    THEN DBMS_OUTPUT.PUT_LINE('High');
    WHEN low
    THEN DBMS_OUTPUT.PUT_LINE('Low');
  END;
END;
/
Low

```

- A user defined exception is processed depending on the following two cases.
  - When an error-code is set
  - When an error-code is not set

It is operated as follows when a user sets an error code.

```

DECLARE
  V1 INTEGER;
  E1 EXCEPTION;
  PRAGMA EXCEPTION_INIT( E1, -12122);
BEGIN
  BEGIN
    V1 := 1 / 0;
  EXCEPTION WHEN E1
    THEN DBMS_OUTPUT.PUT_LINE('SQLCODE = ' || SQLCODE);
    DBMS_OUTPUT.PUT_LINE('SQLERRM = ' || SQLERRM);
  END;
END;
/
SQLCODE = -12122
SQLERRM = [SUNJESOFT][PSM][GOLDILOCKS]divisor is equal to zero

```

The ZERO\_DIVIDE predefined exception exists, but a user sets a handler by setting an error code as E1 exception. For the program compatibility between vendors with each different error code as above, an exception handler is available of which a user directly resets an error code.

A user defined exception in which an error-code is not set is set as the following error code and message in an exception handler.

```

DECLARE
  V1 INTEGER;
  E1 EXCEPTION;
BEGIN
  BEGIN
    RAISE E1;
  EXCEPTION WHEN E1
    THEN DBMS_OUTPUT.PUT_LINE('SQLCODE = ' || SQLCODE);
    DBMS_OUTPUT.PUT_LINE('SQLERRM = ' || SQLERRM);
  END;
END;
/
SQLCODE = 1

```

```
SQLERRM = [SUNJESOFT][PSM][GOLDILOCKS]User-Defined Exception
Anonymous PL block executed.
```

A propagation process of a user defined exception is as same as that of a predefined exception. However, if an error-code is not set in a user defined exception, it is propagated as unhandled user exception error to the superordinate BLOCK.

```
DECLARE
  V1 INTEGER;
  E1 EXCEPTION;
  E2 EXCEPTION;
BEGIN
  BEGIN
    RAISE E1;
  EXCEPTION WHEN E2
    THEN DBMS_OUTPUT.PUT_LINE('SQLCODE = ' || SQLCODE);
    DBMS_OUTPUT.PUT_LINE('SQLERRM = ' || SQLERRM);
  END;
END;
/
ERR-HY000(17017): Unhandled user exception :
  RAISE E1;
  *
ERROR at line 7:
```

An unhandled user exception can be caught by specifying a user defined exception in an exception handler or by using OTHERS which is a predefined exception.

## PRAGMA EXCEPTION\_INIT

It is used for a user sets a specific DBMS error code when using a user defined exception. DBMS error codes varies depending on vendors, so it can be used for a compatibility of an exception handler of PSM code.

The syntax is as follows.

```
<PRAGMA EXCEPTION_INIT> ::=
  PRAGMA EXCEPTION_INIT ( exception_name, internal_errorcode )
```

- Constraints are as follows.
  - exception\_name should be declared in advance.



- exception\_name can not use a predefined exception.
- Only an internal error-code of GOLDILOCKS is available for internal\_errorcode.
- It can not set 0 which means SUCCESS.

The following is an example of handling an exception of when assigning NULL to V1 (the PSM variable to which NOT NULL constraints are applied) by using a user defined exception.

```
DECLARE
  V1 VARCHAR(20) NOT NULL := 10;
  USER_EXCEPT EXCEPTION;
```

- Declare the PSM NOT NULL constraint error as a user defined exception.

```
PRAGMA EXCEPTION_INIT( USER_EXCEPT, -17009 );
BEGIN
```

- Generate a situation of an exception.

```
V1 := NULL;
  EXCEPTION WHEN USER_EXCEPT THEN DBMS_OUTPUT.PUT_LINE('Check Value');
END;
/
Check Value
Anonymous PL block executed.
```

The following error occurs when setting a value which is not an internal error-code of GOLDILOCKS.

```
DECLARE
  E1 EXCEPTION;
  PRAGMA EXCEPTION_INIT( E1, 99999);
BEGIN
  NULL;
END;
/
ERR-HY000(17032): PSM compilation error :
(1) at (3:30): ERR-HY000(17021): Invalid error number for PRAGMA EXCEPTION_INIT
```

## DBMS\_STANDARD.RAISE\_APPLICATION\_ERROR

It is used to easily generate an exception through an arbitrary user error code and a message, instead of explicitly defining a user exception. It belongs to a DBMS\_STANDARD module, and the routines of this module can be called even when omitting a name of that module.

There are three types of arguments as follows.

**Table 23-5** RAISE\_APPLICATION\_ERROR

Argument	Description
error_code IN NATIVE_INTEGER	It is a value of an error code to be arbitrarily generated. Only the value within the range of -20000 ~ -20999 can be used.
error_message IN VARCHAR(4000)	It is a message to be stored in SQLERRM when an error occurs.
stack_flag IN BOOLEAN := FALSE	It is a flag of whether to stack on the existing errors (TRUE), or to replace with all existing errors (FALSE). The default value is FALSE.

The following is a simple example of using it.

```
CREATE OR REPLACE PROCEDURE PROC1
IS
BEGIN
  RAISE_APPLICATION_ERROR (-20000, 'USER DEFINED ERROR TEST');
END;
/
Procedure created.
BEGIN
  PROC1;
EXCEPTION WHEN OTHERS THEN
  DBMS_OUTPUT.PUT_LINE( 'SQLCODE : ' || SQLCODE || ' SQLERRM : ' || SQLERRM );
END;
/
SQLCODE : -20000 SQLERRM : [SUNJESOFT][PSM][GOLDLOCKS]USER DEFINED ERROR TEST
Anonymous PL block executed.
```

**24.**

---

## **PSM Cursor Statements**

## 24.1 Declaration

When retrieving through a PSM statement two or more results can not be returned from the database. Therefore, to retrieve two or more results, a cursor should be used by declaring and defining it.

- Cursors are specified as follows.
  - Explicit cursor
    - A user explicitly declares it through cursor declaration/ definition.
  - Implicit cursor
    - It is a cursor processed through PSM statement within the database, and they can not be defined nor is it declared by a user.

A cursor should be declared and defined in a PSM declare section before using an explicit cursor. (In the following description, a cursor means an explicit cursor.)

- A cursor declaration defines the followings.
  - Cursor name
  - Parameter list owned by a cursor
  - Return type of a cursor
- A cursor definition defines the followings.
  - Cursor name
  - Parameter list owned by a cursor
  - Return type of a cursor
  - SELECT and SELECT .. FOR UPDATE statement which are to be performed by a cursor
- Each item used in a cursor declaration and a cursor definition has the following features.
  - Cursor name
    - A cursor should be unique within the declared SCOPE.
    - The name should be shorter than 128 bytes.
  - Parameter list
    - It is defined when binding a PSM variable or a value in an SQL which is to be performed by a cursor.
  - Return type
    - It is used to strictly define the result set of validating an SQL statement owned by a cursor.
    - If a definition of the result of SQL statement owned by a cursor is different from a definition of the return type, then an error occurs.



A cursor definition should be the same type as the type of the previously declared cursor (name, parameter list, return type).

For a cursor declaration/ definition, refer to the followings.

```
DECLARE
```

- Declaration

```
CURSOR C1 RETURN T1%ROWTYPE;
```

- Declaration & definition

```
CURSOR C2 IS SELECT * FROM T1;
```

- Definition for C1

```
CURSOR C1 RETURN T1%ROWTYPE IS SELECT * FROM T1;
BEGIN
  NULL;
END;
/
```

If the declaration and definition of cursor RETURN TYPE with the same cursor\_name are different, then the following error may occur.

```
gSQL> CREATE TABLE T1
(
  C1 VARCHAR(20),
  C2 VARCHAR(20)
);
Table created.
gSQL> DECLARE
  TYPE rec IS RECORD (C1 VARCHAR(20), C2 VARCHAR(20));
```

The following two cursor return types are same, but it is recognized as using different types. Therefore, an error caused by using the same cursor name occurs.

```
CURSOR C1 RETURN rec;
  CURSOR C1 RETURN T1%ROWTYPE IS SELECT * FROM T1;
BEGIN
  NULL;
END;
/
ERR-HY000(17032): PSM compilation error :
```

(1) at (4:12): ERR-HY000(17033): duplicated cursor name

If the declaration and the definition of items in a parameter list are different, then an error occurs.

DECLARE

- The declaration and the definition of a parameter are different. (Parameter name)

```
CURSOR C1 (A1 INTEGER, A2 INTEGER DEFAULT 10) RETURN T1%ROWTYPE;
  CURSOR C1 (A1 INTEGER, A3 INTEGER DEFAULT 10) RETURN T1%ROWTYPE IS
    SELECT * FROM T1;
BEGIN
  NULL;
END;
/
ERR-HY000(17032): PSM compilation error :
```

(1) at (3:12): ERR-HY000(17033): duplicated cursor name

If an SQL statement defined in a cursor should be performed by referring to a PSM variable at the run-time, then it can be defined with a parameter of a cursor.

```
DECLARE
  cursor c1 (a1 varchar ) return t1%rowtype;
  cursor c2 (a1 varchar(20) ) return t1%rowtype;
BEGIN
  NULL;
END;
/
```

If a DEFAULT clause is defined, the definition of a parameter can be omitted at the time of performing a cursor.

The following is an example of performing a cursor by inputting all parameters, and an example of performing a cursor by omitting the definition of a parameter in a DEFAULT clause.

```
gSQL> CREATE TABLE T1
(
  C1 VARCHAR(20),
  C2 VARCHAR(20)
);
Table created.
gSQL> INSERT INTO T1 VALUES ('Seoul', '24');
1 row created.
```

```

gSQL> INSERT INTO T1 VALUES ('Pusan', '44');
1 row created.
gSQL> DECLARE
    V1 VARCHAR(20);
    V2 VARCHAR(20);
    CURSOR C1 (A1 INTEGER, A2 INTEGER DEFAULT 10)
        IS SELECT * FROM T1 WHERE C2 >= A1 AND C2 <= A2;
BEGIN

```

- Perform a cursor by inputting all parameters.

```

OPEN C1 (10, 50);
    FETCH C1 INTO V1, V2;
    DBMS_OUTPUT.PUT_LINE('V1 = ' || V1 || ' , V2 = ' || V2);
    CLOSE C1;

```

- Perform a cursor by omitting a default parameter (A2).

```

OPEN C1 (10);
    FETCH C1 INTO V1, V2;
    IF C1%NOTFOUND = TRUE
    THEN
        DBMS_OUTPUT.PUT_LINE('NO DATA');
    END IF;
    CLOSE C1;
END;
/
V1 = Seoul , V2 = 24
NO DATA
Anonymous PL block executed.

```

## 24.2 OPEN

A select statement of a cursor can be performed through OPEN statement after declaration/ definition of the explicit cursor. If it is a SELECT .. FOR UPDATE statement, it locks rows in a result set.

If a cursor OPEN again a CURSOR which is normally OPEN, then an error occurs.

```

DECLARE
  V1 VARCHAR(20);
  V2 VARCHAR(20);
  CURSOR C1 IS SELECT * FROM T1;
BEGIN

  OPEN C1;
  OPEN C1;
END;
/
ERR-HY000(17037): cursor is already open :
  OPEN C1;
  *
ERROR at line 9:

```

If an explicit cursor has a parameter, then it is used as follows.

```

DECLARE
  v1 VARCHAR(20);
  v2 VARCHAR(20);
  cursor c1 (a1 varchar(20) ) return t1%rowtype;
  cursor c1 (a1 varchar(20) ) return t1%rowtype
  is select * from t1 where c1 = a1;
BEGIN
  OPEN c1( 'Seoul' );
  FETCH c1 INTO V1, V2;
  DBMS_OUTPUT.PUT_LINE('V1 = ' || V1 || ' , V2 = ' || V2);

END;
/
V1 = Seoul , V2 = 24
Anonymous PL block executed.

```

For more information, refer to **OPEN Statement**.



## 24.3 FETCH

If an explicit cursor is normally OPEN, a result can be stored as a PSM variable through a FETCH statement.

- A result is stored in the following PSM variables.
  - SQL data type variable
  - A record type variable which can store a single row
  - An associative array type variable in which a key is specified available to store a single row

The following is an example of fetching by using an SQL data type variable or through %ROWTYPE.

```
DECLARE
V1 VARCHAR(20);
V2 VARCHAR(20);
V3 T1%ROWTYPE;
CURSOR C1 IS SELECT * FROM T1;
BEGIN
OPEN C1;
```

- List of SQL type variables

```
FETCH C1 INTO V1, V2;
DBMS_OUTPUT.PUT_LINE('V1 = ' || V1 || ' , V2 = ' || V2);
```

- Single record variables

```
FETCH C1 INTO V3;
DBMS_OUTPUT.PUT_LINE('V3.C1 = ' || V3.C1 || ' , V3.C2 = ' || V3.C2);
END;
/
V1 = Seoul , V2 = 24
V3.C1 = Pusan , V3.C2 = 44
```

A record type variable used in FETCH should be separately used, and if it is used together with another variable, then an error occurs as follows.

```
gSQL> CREATE TABLE T1
(
  C1 VARCHAR(20),
  C2 VARCHAR(20)
);
```

Table created.

```
gSQL> INSERT INTO T1 VALUES ('Seoul', '24');
```

1 row created.

```
gSQL> INSERT INTO T1 VALUES ('Pusan', '44');
```

1 row created.

```
gSQL> DECLARE
```

```
    V1 VARCHAR(20);
```

```
    V2 VARCHAR(20);
```

```
    V3 T1%ROWTYPE;
```

```
    CURSOR C1 (A1 INTEGER, A2 INTEGER DEFAULT 10)
```

```
        IS SELECT * FROM T1 WHERE C2 >= A1 AND C2 <= A2;
```

```
BEGIN
```

```
    OPEN C1 (10, 50);
```

V3 is a record type and a scalar type return result can not be stored in a record type, so an error occurs.

```
FETCH C1 INTO V1, V3;
```

```
    CLOSE C1;
```

```
END;
```

```
/
```

```
ERR-HY000(17032): PSM compilation error :
```

```
(1) at (10:23): ERR-HY000(17007): invalid expression
```

For more information, refer to **FETCH Statement**.

## 24.4 CLOSE

It closes a cursor which is normally OPEN. Results and cursor-attributes can not be obtained from a closed cursor. When accessing to a CLOSE cursor and performing fetch, then an INVALID\_CURSOR exception.

```
DECLARE
  V1 VARCHAR(20);
  V2 VARCHAR(20);
  CURSOR C1 IS SELECT * FROM T1;
BEGIN

  OPEN C1;
  CLOSE C1;
  BEGIN
    FETCH C1 INTO V1, V2;
  EXCEPTION WHEN INVALID_CURSOR
    THEN DBMS_OUTPUT.PUT_LINE('invalid cursor exception');
  END;
END;
/
invalid cursor exception
Anonymous PL block executed.
```

For more information, refer to [CLOSE Statement](#).

## 24.5 EXPLICIT CURSOR ATTRIBUTES

Explicit cursor attributes have the information about the current status of an explicit cursor. These attributes can be used both in an expression and a conditional expression.

An explicit cursor attribute is used as the following syntax, and refer to the following table for more information about attributes.

```
Cursor_Name % Attribute_name
Attribute_name := ISOPEN
                | FOUND
                | NOTFOUND
                | ROWCOUNT
```

**Table 24-1** Cursor attributes

Attribute	Return type	Description
%ISOPEN	BOOLEAN	It is TRUE only when a cursor is normally open. Otherwise, it is FALSE.
%FOUND	BOOLEAN	It is NULL before FETCH, and it is TRUE when FETCH is normally performed. It is FALSE when data does not exist, and it is NULL after CLOSE.
%NOTFOUND	BOOLEAN	It is the opposite value of %FOUND.
%ROWCOUNT	INTEGER	It is NULL before OPEN, and it is 0 when it is normally OPEN. It increases by 1 whenever FETCH succeeds.

The following is an example of displaying how the value is changed by phase for each cursor attribute.

```
DECLARE
  V1 VARCHAR(20);
  V2 VARCHAR(20);
  CURSOR C1 IS SELECT * FROM T1;
BEGIN

  DBMS_OUTPUT.PUT_LINE('<BEFORE OPEN>');
  DBMS_OUTPUT.PUT_LINE('%ISOPEN   = [' || C1%ISOPEN   || ']');
  DBMS_OUTPUT.PUT_LINE('%FOUND     = [' || C1%FOUND     || ']');
  DBMS_OUTPUT.PUT_LINE('%NOTFOUND  = [' || C1%NOTFOUND  || ']');
  DBMS_OUTPUT.PUT_LINE('%ROWCOUNT = [' || C1%ROWCOUNT || ']');
  OPEN C1;
  DBMS_OUTPUT.PUT_LINE('<AFTER OPEN>');
  DBMS_OUTPUT.PUT_LINE('%ISOPEN   = [' || C1%ISOPEN   || ']');
```

```

DBMS_OUTPUT.PUT_LINE('%FOUND      = [ ' || C1%FOUND      || ' ]');
DBMS_OUTPUT.PUT_LINE('%NOTFOUND = [ ' || C1%NOTFOUND || ' ]');
DBMS_OUTPUT.PUT_LINE('%ROWCOUNT = [ ' || C1%ROWCOUNT || ' ]');
FETCH C1 INTO V1, V2;
DBMS_OUTPUT.PUT_LINE('<AFTER FETCH>');
DBMS_OUTPUT.PUT_LINE('%ISOPEN   = [ ' || C1%ISOPEN   || ' ]');
DBMS_OUTPUT.PUT_LINE('%FOUND     = [ ' || C1%FOUND     || ' ]');
DBMS_OUTPUT.PUT_LINE('%NOTFOUND = [ ' || C1%NOTFOUND || ' ]');
DBMS_OUTPUT.PUT_LINE('%ROWCOUNT = [ ' || C1%ROWCOUNT || ' ]');
CLOSE C1;
DBMS_OUTPUT.PUT_LINE('<AFTER CLOSE>>');
DBMS_OUTPUT.PUT_LINE('%ISOPEN   = [ ' || C1%ISOPEN   || ' ]');
DBMS_OUTPUT.PUT_LINE('%FOUND     = [ ' || C1%FOUND     || ' ]');
DBMS_OUTPUT.PUT_LINE('%NOTFOUND = [ ' || C1%NOTFOUND || ' ]');
DBMS_OUTPUT.PUT_LINE('%ROWCOUNT = [ ' || C1%ROWCOUNT || ' ]');
END;
/
<BEFORE OPEN>
%ISOPEN   = [FALSE]
%FOUND     = []
%NOTFOUND = []
%ROWCOUNT = []
<AFTER OPEN>
%ISOPEN   = [TRUE]
%FOUND     = []
%NOTFOUND = []
%ROWCOUNT = [0]
<AFTER FETCH>
%ISOPEN   = [TRUE]
%FOUND     = [TRUE]
%NOTFOUND = [FALSE]
%ROWCOUNT = [1]
<AFTER CLOSE>>
%ISOPEN   = [FALSE]
%FOUND     = []
%NOTFOUND = []
%ROWCOUNT = []

```

Anonymous PL block executed.

## 24.6 IMPLICIT\_CURSOR\_ATTRIBUTES

An implicit cursor is a cursor internally processed in a database through a PSM statement, and it has attributes whose name is as same as that of attributes owned by an explicit cursor.

For more information, refer to the following table.

**Table 24-2** Implicit cursor attributes

Attribute name	Return type	Description
ISOPEN	BOOLEAN	It is always FALSE because it is internally closed.
FOUND	BOOLEAN	If the data is returned by the previous statement, then it is TRUE. Otherwise, it is FALSE.
NOTFOUND	BOOLEAN	It is the opposite value of FOUND.
ROWCOUNT	INTEGER	It is the number of rows affected by the previous statement.

The following is an example of implicit cursor attributes.

```

gSQL> CREATE TABLE T1
(
  C1 VARCHAR(20),
  C2 VARCHAR(20)
);
Table created.
gSQL> INSERT INTO T1 VALUES ('Seoul', '24');
1 row created.
gSQL> INSERT INTO T1 VALUES ('Pusan', '44');
1 row created.
gSQL> DECLARE
V1 INTEGER;
BEGIN
  SELECT COUNT(*) INTO V1 FROM T1;
  DBMS_OUTPUT.PUT_LINE('COUNT RET    = ' || V1);
  DBMS_OUTPUT.PUT_LINE('SQL%ISOPEN  = ' || SQL%ISOPEN);
  DBMS_OUTPUT.PUT_LINE('SQL%FOUND   = ' || SQL%FOUND);
  DBMS_OUTPUT.PUT_LINE('SQL%NOTFOUND = ' || SQL%NOTFOUND);
  DBMS_OUTPUT.PUT_LINE('SQL%ROWCOUNT = ' || SQL%ROWCOUNT);
END;
/
COUNT RET    = 2
SQL%ISOPEN    = FALSE
SQL%FOUND     = TRUE

```

```
SQL%NOTFOUND = FALSE
```

```
SQL%ROWCOUNT = 1
```

```
Anonymous PL block executed.
```

## 24.7 CURSOR VARIABLES

A cursor variable is a concept similar to an explicit cursor. However, an explicit cursor is subordinate to a single statement, a cursor variable plays a role as a point indicating one or more cursor. In other words, it can use a cursor by altering SQL syntaxes by using a single cursor variable.

- The followings are what are different from an explicit cursor.
  - It alters one or more SELECT queries and processes them with a cursor.
  - It is possible to assign each cursor variable among cursor variables.
  - It can be used in an expression.
  - It can be used as a parameter of a subprogram and schema-level procedure/ function.
  - It can not have a parameter.

It is automatically closed if a cursor open through a cursor variable gets out of the SCOPE where the cursor is declared. However, if it is used as a parameter of a subprogram and schema\_level procedure/ function, then it is valid even when that procedure/ function ends until it gets out of the SCOPE where it was called.



To use a cursor variable as a parameter, a binding-mode of that parameter should be declared as OUT or IN OUT.

A cursor variable can use cursor attributes as same as those of an explicit cursor.

```

DECLARE
  v1 VARCHAR(20);
  v2 VARCHAR(20);
  cv1 SYS_REFCURSOR;
BEGIN
  DBMS_OUTPUT.PUT_LINE('Before Open');
  DBMS_OUTPUT.PUT_LINE('ISOPEN   = ' || cv1%ISOPEN );
  DBMS_OUTPUT.PUT_LINE('FOUND     = ' || cv1%FOUND );
  DBMS_OUTPUT.PUT_LINE('NOTFOUND = ' || cv1%NOTFOUND );
  DBMS_OUTPUT.PUT_LINE('ROWCOUNT = ' || cv1%ROWCOUNT );
  OPEN cv1 FOR SELECT * FROM T1;
  DBMS_OUTPUT.PUT_LINE('After Open');
  DBMS_OUTPUT.PUT_LINE('ISOPEN   = ' || cv1%ISOPEN );
  DBMS_OUTPUT.PUT_LINE('FOUND     = ' || cv1%FOUND );
  DBMS_OUTPUT.PUT_LINE('NOTFOUND = ' || cv1%NOTFOUND );
  DBMS_OUTPUT.PUT_LINE('ROWCOUNT = ' || cv1%ROWCOUNT );

```



```

FETCH cv1 INTO V1, V2;
DBMS_OUTPUT.PUT_LINE('After fetch');
DBMS_OUTPUT.PUT_LINE('ISOPEN   = ' || cv1%ISOPEN );
DBMS_OUTPUT.PUT_LINE('FOUND     = ' || cv1%FOUND );
DBMS_OUTPUT.PUT_LINE('NOTFOUND = ' || cv1%NOTFOUND );
DBMS_OUTPUT.PUT_LINE('ROWCOUNT = ' || cv1%ROWCOUNT );

```

```
END;
```

```
/
```

```
Before Open
```

```
ISOPEN   = FALSE
```

```
FOUND     =
```

```
NOTFOUND =
```

```
ROWCOUNT =
```

```
After Open
```

```
ISOPEN   = TRUE
```

```
FOUND     =
```

```
NOTFOUND =
```

```
ROWCOUNT = 0
```

```
After fetch
```

```
ISOPEN   = TRUE
```

```
FOUND     = TRUE
```

```
NOTFOUND = FALSE
```

```
ROWCOUNT = 1
```

Anonymous PL block executed.

Cursor variable can be used as a parameter of a subprogram and a schema-level procedure/ function as follows.

```
gSQL> CREATE TABLE T1
```

```
(
```

```
  C1 VARCHAR(20),
```

```
  C2 VARCHAR(20)
```

```
);
```

Table created.

```
gSQL> INSERT INTO T1 VALUES ('Seoul', '24');
```

1 row created.

```
gSQL> INSERT INTO T1 VALUES ('Pusan', '44');
```

1 row created.

```
gSQL> DECLARE
```

```
  v1 VARCHAR(20);
```

```
v2 VARCHAR(20);
cv1 SYS_REFCURSOR;
PROCEDURE PROC1 ( A_CV1 IN OUT SYS_REFCURSOR )
IS
BEGIN
```

- Open a cursor by using an input parameter cursor variable.

```
OPEN A_CV1 FOR SELECT * FROM T1;
END;
BEGIN
PROC1( cv1 );
```

- Fetch it by using a cursor variable which was used as a parameter.

```
FETCH cv1 INTO V1, V2;
DBMS_OUTPUT.PUT_LINE('V1 = ' || V1 || ' , V2 = ' || V2);

END;
/
V1 = Seoul , V2 = 24
Anonymous PL block executed.
```

For more information, refer to [Cursor Variable Declaration](#).

## OPEN and Close Cursor Variables

It can OPEN a cursor through a cursor variable if using an OPEN FOR statement within PSM. Also, it can CLOSE a cursor of a cursor variable through a CLOSE statement as same as an explicit cursor.

If an already open cursor exists in a cursor variable at the time of performing a cursor through an OPEN FOR statement, then that cursor is automatically closed and a new cursor is OPEN.

The following is an example of using a cursor variable.

```
gSQL> CREATE TABLE T1
(
  C1 VARCHAR(20),
  C2 VARCHAR(20)
);
Table created.
```

```

gSQL> INSERT INTO T1 VALUES ('Seoul', '24');
1 row created.
gSQL> INSERT INTO T1 VALUES ('Pusan', '44');
1 row created.
gSQL> DECLARE
  v1 VARCHAR(20);
  v2 VARCHAR(20);
  cv1 SYS_REFCURSOR;
BEGIN
  OPEN cv1 FOR SELECT * FROM T1;

```

- Fetch with cursor-variable

```

FETCH cv1 INTO V1, V2;

  DBMS_OUTPUT.PUT_LINE('V1 = ' || V1 || ' , V2 = ' || V2);
  CLOSE cv1;
END;
/
V1 = Seoul , V2 = 24
Anonymous PL block executed.

```

For more information, refer to [OPEN FOR Statement](#), [CLOSE Statement](#).

## Fetching Data With Cursor Variables

Like as an explicit cursor, it can store the result processed in a database through a fetch statement as a PS M variable.

For more information, refer to [FETCH Statement](#).

## Assign Values to Cursor Variables

It is possible to assign a cursor variable each other if RETURN-TYPEs are same. If it is not a cursor variable type, then an error occurs.

It is performed with the following assign statement.

```
target_cursor_variable := source_cursor_variable
```

Assigning a cursor variable makes a cursor pointer indicated by target\_cursor\_variable indicate a cursor having Source\_cursor\_variable. Therefore, after it is normally assigned, a cursor already open in a target cursor variable is not valid nor is it accessible. Also, a cursor is internally cleared when getting out of the SCOPE in which a cursor variable is declared.

```
DECLARE
  v1 VARCHAR(20);
  v2 VARCHAR(20);
  cv1 SYS_REFCURSOR;
  cv2 SYS_REFCURSOR;
BEGIN
```

- Open cv1

```
OPEN cv1 FOR SELECT * FROM T1;
```

- Assign cv1 to cv2

```
cv2 := cv1;
```

- Fetch from cv2

```
FETCH cv2 INTO V1, V2;
  DBMS_OUTPUT.PUT_LINE('V1 = ' || V1 || ' , V2 = ' || V2);

END;
/
V1 = Seoul , V2 = 24
```

The following is an example of using the same cursor by assigning after each cursor variable performs OPEN.

```
gSQL> CREATE TABLE T1
(
  C1 VARCHAR(20),
  C2 VARCHAR(20)
);
Table created.
gSQL> INSERT INTO T1 VALUES ('Seoul', '24');
1 row created.
```

```
gSQL> INSERT INTO T1 VALUES ('Pusan', '44');  
1 row created.  
gSQL> DECLARE  
  cv1 SYS_REFCURSOR;  
  cv2 SYS_REFCURSOR;  
  v1 t1%ROWTYPE;  
BEGIN
```

- Each cursor variable OPEN a cursor.

```
OPEN cv1 FOR select * from t1 where c1 = 'Seoul';  
OPEN cv2 FOR select * from t1 where c1 = 'Pusan';
```

- Assign cursor-variable
- A cursor of cv2 is not valid any more.

```
cv2 := cv1;
```

- Fetch the result of cv1.

```
FETCH cv2 INTO v1;  
  
  DBMS_OUTPUT.PUT_LINE('C1 = ' || v1.C1 || ' , C2 = ' || v1.C2);  
END;  
/  
C1 = Seoul , C2 = 24  
Anonymous PL block executed.
```



**25.**

---

## **Using PSM Subprograms**

## 25.1 Anonymous PL Block

An anonymous PL block is an SQL statement for a one-time execution of a PSM statement instead of storing a PSM statement in the database. An anonymous PL block is a one of a regular SQL provided by GOLDILOCKS, so it is used in the same way as other SQLs in ODBC, JDBC and precompiler which are provided by GOLDILOCKS. A syntax is as same as a syntax of a general basic block. For more information, refer to **Block (BEGIN .. END)**.

```

<<Label>> ① (optional)
DECLARE ② (optional)
③ declare items (variables, cursors, types, ...) (optional)
BEGIN ④ (required)
⑤ PSM statements to execute (required)
EXCEPTION ⑥ Exception Handling Part (optional)
END;

```

Refer to the following instructions when using an anonymous PL block.

Interface	Instructions for use
in common	A bind parameter can be used unlike a schema-level procedure/ function. It also supports a prepare-execute method.
ODBC	It is used completely same as a general SQL.
JDBC	A CallableStatement class should be used if it has a bind parameter with IN-OUT or OUT attribute. (Refer to <b>CallableStatement</b> .)
Precompiler (gpec)	N/A
Interactive command tool (gsq)	It should notify the end of the statement by entering '/'<Enter> after inputting an anonymous PL block.



## 25.2 Nested Procedure

A nested procedure is a procedure type subprogram declared within a specific PL block. A nested procedure has a scope which can be referenced only on a declared PL block and its subordinates.

For more information, refer to **Procedure Declaration and Definition**.

```

DECLARE
  PROCEDURE PROC1( A1 INTEGER ) ❶ Define Nested Procedure
  IS
  BEGIN
    DBMS_OUTPUT.PUT_LINE( 'A1 = ' || A1 );
  END;
BEGIN
  PROC1( 100 ); ❷ Call Nested Procedure
END;
/

```

The followings are items available within a nested subprogram.

- An argument variable of a nested subprogram
- A PL block in which a nested subprogram is defined, and variables and various items (type, cursor,...) defined in its superordinate scope.
- A bind parameter when it is an anonymous PL block. (e.g. '?', ':V1')

A nested procedure supports a forward declaration, so it can separately specify a declare statement and a define statement. By using this, a logic of cross call between two nested procedures can be implemented.

```

gSQL> DECLARE
  PROCEDURE PROC1( A1 INTEGER ); ❶ declare proc1
  PROCEDURE PROC2( A1 INTEGER ) ❷ define proc2
  IS
  BEGIN
    IF A1 > 0 THEN
      DBMS_OUTPUT.PUT_LINE( '(proc2)A1 = ' || A1 );
      PROC1( A1 -1 ); ❸ call proc1
    END IF;
  END;
PROCEDURE PROC1( A1 INTEGER ) ❹ define proc1
IS
BEGIN
  IF A1 > 0 THEN

```

```

        DBMS_OUTPUT.PUT_LINE( '(proc1)A1 = ' || A1 );
        PROC2( A1 -1 ); ⑤ call proc2
    END IF;
END;
BEGIN
    PROC1(5); ⑥ call proc1
END;
/

```

(proc1)A1 = 5

(proc2)A1 = 4

(proc1)A1 = 3

(proc2)A1 = 2

(proc1)A1 = 1

Anonymous PL block executed.

GOLDILOCKS PSM limits the maximum subordinate statement depths to 50 to prevent the infinite cross referencing. If it is exceeded, then the following error occurs. (It is also applied same to a nested function, schema-level procedure/ function.)

```

gSQL> DECLARE
    PROCEDURE PROC1( A1 INTEGER ); ① declare proc1
    PROCEDURE PROC2( A1 INTEGER ) ② define proc2
    IS
    BEGIN
        DBMS_OUTPUT.PUT_LINE( 'A1 = ' || A1 );
        PROC1( A1 -1 );
    END;
    PROCEDURE PROC1( A1 INTEGER ) ③ define proc1
    IS
    BEGIN
        DBMS_OUTPUT.PUT_LINE( 'A1 = ' || A1 );
        PROC2( A1 -1 );
    END;
BEGIN
    PROC1(100);
END;
/

```

ERR-42000(16411): maximum number of recursive SQL levels (50) exceeded.

## 25.3 Nested Function

A nested function is as same as a nested procedure, but it is a subprogram in function form. For more information, refer to [Function Declaration and Definition](#).

```
gSQL> DECLARE
  V1 INTEGER := 0;
  FUNCTION FUNC1( A1 INTEGER )
    RETURN INTEGER
  IS
  BEGIN
    RETURN A1 * 10;
  END;
BEGIN
  V1 := FUNC1( 10 );
  DBMS_OUTPUT.PUT_LINE( 'V1 = ' || V1 );
END;
/
V1 = 100
```

Anonymous PL block executed.

A nested function can be used in all PSM expressions within a visible scope, but is can not be used in an SQL statement.

```
gSQL> DECLARE
  V1 INTEGER := 0;
  FUNCTION FUNC1( A1 INTEGER )
    RETURN INTEGER
  IS
  BEGIN
    RETURN A1 * 10;
  END;
BEGIN
  SELECT FUNC1(10) INTO V1 FROM DUAL;
  DBMS_OUTPUT.PUT_LINE( 'V1 = ' || V1 );
END;
/
```

ERR-HY000(17032): PSM compilation error :

(1) at (10:3): ERR-HY000(17079): a nested function not allowed in executing SQL

## 25.4 Schema-level Procedure

A schema-level subprogram is an SQL object which has a name and is stored in a database. A schema-level procedure is a schema-level subprogram in procedure form.

### Creating Schema-level Procedure

A schema-level procedure is created as follows. A precision and a scale value should be specified if in need.

For more information, refer to **CREATE PROCEDURE**.

```
CREATE OR REPLACE PROCEDURE PROC1( A1 INTEGER, A2 INTEGER )
IS
  V1 INTEGER;
BEGIN
  SELECT COUNT(*)
  INTO V1
  FROM T1
  WHERE T1.I1 >= A1 AND T1.I1 <= A2;
  DBMS_OUTPUT.PUT_LINE( 'V1 = ' || V1 );
END;
/
```

The information about a created schema-level procedure can be found with a **INFORMATION\_SCHEMA.ROUTINES** table.

For more information, refer to **ROUTINES**.

```
gSQL> SELECT SPECIFIC_NAME, ROUTINE_DEFINITION
FROM INFORMATION_SCHEMA.ROUTINES
WHERE SPECIFIC_NAME = 'PROC1';
SPECIFIC_NAME ROUTINE_DEFINITION
-----
PROC1          PROCEDURE "PUBLIC"."PROC1" ( A1 INTEGER, A2 INTEGER )
IS
  V1 INTEGER;
BEGIN
  SELECT COUNT(*)
  INTO V1
```

```

        FROM T1
        WHERE T1.I1 >= A1 AND T1.I1 <= A2;
        DBMS_OUTPUT.PUT_LINE( 'V1 = ' || V1 );
    END;

```

1 row selected.

The information about an argument can be found with a `INFORMATION_SCHEMA.PARAMETERS` table. For more information, refer to **PARAMETERS**.

```

gSQL> SELECT P.PARAMETER_NAME, P.ORDINAL_POSITION
      FROM INFORMATION_SCHEMA.ROUTINES    R,
           INFORMATION_SCHEMA.PARAMETERS P
      WHERE R.SPECIFIC_NAME = 'PROC1'
            AND R.SPECIFIC_SCHEMA = P.SPECIFIC_SCHEMA
            AND R.SPECIFIC_NAME = P.SPECIFIC_NAME
      ORDER BY P.ORDINAL_POSITION;

```

PARAMETER_NAME	ORDINAL_POSITION
A1	1
A2	2

2 rows selected.

## Using Schema-level Procedure

A schema-level procedure is used by an inner statement of other PSM or by a `CALL` statement. Other PSM statements call a schema-level procedure in the same form of a nested procedure.

```

gSQL> BEGIN
      PROC1( 2, 4 ); ❶ Call schema-level procedure
    END;
/
V1 = 3

```

Anonymous PL block executed.

A `CALL` statement which is an SQL executing the given PSM is executed as follows. For more information, refer to **CALL Statement**.

```
gSQL> CALL PROC1( 2, 4 );
V1 = 3
Procedure Call complete.
```

It supports the following syntax for a procedure to support a procedure call escape sequence used in ODBC or JDBC.

```
{ CALL procedure_name( param1, param2, ... ) }
```

A syntax of a procedure call escape sequence is used like as a general SQL.

```
gSQL> { CALL PROC1(2, 4) };
V1 = 3
Procedure Call complete.
```

gsq which is an interactive command tool of GOLDILOCKS does not support performing a procedure through \EXEC which is the tool's own command.

The following options about a privilege of when executing a schema-level procedure can be specified. If a user except for a definer performs an SQL within PSM according to these options, it may refer to a table with the same name in different schemas according to the definition of that user's schema-path. (A name of the object used when declaring an item (e.g. T1%ROWTYPE) is always interpreted as a definer.)

- AUTHID DEFINER (default): The user is altered to the user created that procedure, then it is performed.
- AUTHID CURRENT\_USER: The user is not altered, and it is performed by the current user.

```
CREATE OR REPLACE PROCEDURE "PROC1"( A1 INTEGER, A2 INTEGER )
AUTHID CURRENT_USER
IS
  V1 INTEGER;
BEGIN
  SELECT COUNT(*)
  INTO V1
  FROM T1
  WHERE T1.I1 >= A1 AND T1.I1 <= A2;
  DBMS_OUTPUT.PUT_LINE( 'V1 = ' || V1 );
END;
/
```

## Dropping Schema-level Procedure

A schema-level procedure is dropped by the following DROP PROCEDURE statement. For more information, refer to **DROP PROCEDURE**.

```
DROP PROCEDURE PROC1;
```

It also supports IF EXISTS statement like as other DROP statements of GOLDILOCKS.

```
DROP PROCEDURE IF EXISTS PROC1;
```

## Recompiling Schema-level Procedure

If an object referenced inside of a schema-level subprogram is altered, then it may affect the corresponding subprogram and should create the execution plan again.

### Referenced Object in a Declarative Part or an Argument

If the used object is altered when defining various items in a declarative part or an argument type, then the procedure plan is automatically recompiled.

- An object used in %TYPE, %ROWTYPE
- An object used in an explicit cursor definition statement

If the corresponding procedure is performed for the first time after an object is altered, then the plan is automatically recreated according to the following order.

1. Bring the plan of the corresponding procedure from a plan cache.
2. Search for objects which were altered during validating an object list of that plan.
3. Discard the current plan, and create a new plan from a procedure definition statement stored in a dictionary.
4. Register a newly created plan on a plan cache.
5. Execute the plan.

### Referenced Object in an SQL of the Body

An SQL plan used in the body is not stored in a procedure plan, and only the SQL text is stored. When executing a procedure, it creates a plan by compiling the corresponding SQL statement in real time, then executes it. Therefore, an SQL object used within a body does not affect the procedure plan itself.

However, if an object is altered, the number or type of binds which are the existing interfaces of a procedure may be altered, or columns may be dropped. Therefore, an error may occur when executing it if the procedure is not appropriately altered.



## 25.5 Schema-level Function

A schema-level function is a schema-level subprogram in function form, which is used within an expression.

### Creating Schema-level Function

A schema-level function is created as follows. A precision and a scale value of an argument type should be specified if in need.

For more information, refer to **CREATE FUNCTION**.

```
gSQL> CREATE OR REPLACE FUNCTION FUNC1( A1 INTEGER, A2 INTEGER )
RETURN INTEGER
IS
  V1 INTEGER;
BEGIN
  SELECT COUNT(*)
  INTO V1
  FROM T1
  WHERE T1.I1 >= A1 AND T1.I1 <= A2;
  RETURN V1;
END;
/
Function created.
```

Like as a procedure, a created schema-level function is found through **INFORMATION\_SCHEMA.ROUTINES** and **INFORMATION\_SCHEMA.PARAMETERS** table.

### Using Schema-level Function

A schema-level function can be used in all expressions in which a general SQL or an SQL object within **PSM** can be used.

```
gSQL> SELECT FUNC1( 2, 4 ) FROM DUAL;
FUNC1( 2, 4 )
-----
          3
```

1 row selected.

It is used as follows within PSM.

```
gSQL> DECLARE
  V1 INTEGER;
BEGIN
  V1 := FUNC1( 2, 4 );
  DBMS_OUTPUT.PUT_LINE( 'V1 = ' || V1 );
END;
/
V1 = 3
Anonymous PL block executed.
```

It can be performed by using CALL statement as follows.

For more information, refer to **CALL Statement**.

```
gSQL> \var V1 INTEGER
gSQL> CALL FUNC1( 2, 4 ) INTO :V1;
Procedure Call complete.
gSQL> \print V1
V1
--
3
```

Like as a schema-level procedure, a procedure call escape sequence statement is also supported.

```
{ ? = CALL function_name( param1, param2, ... ) }
```

```
gSQL> { :V1 = CALL FUNC1( 2, 4 ) };
Procedure Call complete.
gSQL> \print V1
V1
--
3
```

## Dropping Schema-level Function

A schema-level function is dropped by the following DROP FUNCTION statement.

For more information, refer to **DROP FUNCTION**.

```
gSQL> DROP FUNCTION FUNC1;  
Function dropped.
```

## 25.6 Built-in Procedures

GOLDILOCKS PSM provides the following built-in procedures to debug or process the exception when materializing the procedure and the function.

**Table 25-1** Built-in procedures

Procedure	Description
DBMS_OUTPUT.ENABLE( buffer_size IN NATIVE_INTEGER := 20000 )	It activates a message logging feature to the given buffer size. If the buffer size is not given it is set to 20000 bytes by default. If the feature is already activated then it discards all messages and creates a new buffer.
DBMS_OUTPUT.DISABLE	It deactivates a message logging feature. All messages previously logged are discarded.
DBMS_OUTPUT.SET_LOG( file_path IN VARCHAR(4000) )	It simultaneously outputs on the file in a given path when logging a message. If the given path is a relative path (its first letter is not /), then it searches for a target file below a directory corresponding to <SYSTEM_LOGGER_DIR> property.  Specify the permission as follows. <ul style="list-style-type: none"> <li>CALL DBMS_OUTPUT.SET_LOG( 'a.txt' , 640 )</li> </ul>
DBMS_OUTPUT.PUT_LINE( item IN VARCHAR(4000) )	It stores a message created with a given expression including the new line character on a buffer.
DBMS_OUTPUT.PUT( item IN VARCHAR(4000) )	It stores a message created with a given expression on a buffer.
DBMS_OUTPUT.NEW_LINE	It stores the new line character on a buffer.
DBMS_OUTPUT.GET_LINE( line OUT VARCHAR(4000), status OUT NATIVE_INTEGER )	It returns the oldest single message line which is not read among messages stored on a buffer. If there is a message, a status returns 0, if there is not any message it returns 1.
DBMS_STANDARD.RAISE_APPLICATION_ERROR( error_code IN NATIVE_INTEGER, error_message IN VARCHAR(4000), stack_flag IN BOOLEAN := FALSE )	It generates an arbitrary user exception. and error_code should be the value between -20000 and -20999. If it is TRUE, the last stack_flag argument stacks a given error on the existing errors. If it is FALSE, the corresponding error replaces all errors. (It can be omitted, and the default is FALSE when it is omitted.)

```
gSQL> DECLARE
V1 VARCHAR(1024);
V2 INTEGER;
BEGIN
  DBMS_OUTPUT.ENABLE(2000);
  DBMS_OUTPUT.PUT_LINE('TEST MSG');
  DBMS_OUTPUT.GET_LINE( V1, V2);
  DBMS_OUTPUT.PUT_LINE('V1 = ' || v1);
```

```

    DBMS_OUTPUT.PUT_LINE('V2 = ' || v2);
END;
/
V1 = TEST MSG
V2 = 0
Anonymous PL block executed.

```

A message logging feature is managed per each section, and gsql (an interactive command tool of GOLD ILOCKS) can turn on or off the message logging feature with a serveroutput option. If any content remains in a message buffer after performing PSM, all are automatically output.

```

gSQL> \set serveroutput on
gSQL> \var msg VARCHAR(4000)
gSQL> \var status NATIVE_INTEGER
gSQL> CALL DBMS_OUTPUT.PUT_LINE( 'aaa' );
aaa
Procedure Call complete.
gSQL> CALL DBMS_OUTPUT.PUT_LINE( 'bbb' );
bbb
Procedure Call complete.
gSQL> CALL DBMS_OUTPUT.GET_LINE( :msg, :status );
Procedure Call complete.
gSQL> \print msg
MSG
----
null
gSQL> \print status
STATUS
-----
1

```



**26.**

---

## **Using SQLs in PSM**

## 26.1 Static SQLs

Static SQLs are SQLs that can be used in PSM, and they are classified as follows.

- SELECT
- INSERT
- UPDATE
- DELETE
- RETURNING INTO
- LOCK TABLE
- COMMIT, ROLLBACK, SAVEPOINT

A static SQL is an extended SQL to perform SQL supported by GOLDILOCKS through PSM variables. This chapter describes features and precautions of a static SQL available only in PSM.

### SELECT

A SELECT statement within PSM receives the result returned from the database, and stores the value in a PSM variable specified in the INTO clause. The result set of GOLDILOCKS PSM through SELECT INTO can be stored only in a single row.

It can be specified as follows.

```
SELECT target_list INTO variable_list FROM table_expression
```

For more information, refer to **Data Query Language**.

The following is an example of storing a value in a variable declared as an SQL data type by using SELECT statement within PSM.

```
DECLARE
  V1 INTEGER;
BEGIN
  DBMS_OUTPUT.PUT_LINE( 'V1 = [' || V1 || ']');
```

- It stores the result in the variable V1 through SELECT INTO.

```
SELECT 1 INTO V1 FROM DUAL;
DBMS_OUTPUT.PUT_LINE( 'V1 = ' || V1);
END;
```



```

/
V1 =[]
V1 = 1

```

The following is an example of storing value in a variable declared as a record type.

```

DECLARE
  TYPE rec is RECORD (F1 INTEGER, F2 INTEGER );
  var1 rec;
BEGIN
  DBMS_OUTPUT.PUT_LINE( 'Var1.f1 =[ ' || Var1.f1 || ' ]');
  DBMS_OUTPUT.PUT_LINE( 'Var1.f2 =[ ' || Var1.f2 || ' ]');

```

- Store the result in var which is a record type variable.

```

SELECT 1, 2 INTO var1 FROM DUAL;
  DBMS_OUTPUT.PUT_LINE( 'Var1.f1 = ' || Var1.f1);
  DBMS_OUTPUT.PUT_LINE( 'Var1.f2 = ' || Var1.f2);
END;
/
Var1.f1 =[
Var1.f2 =[
Var1.f1 = 1
Var1.f2 = 2

```

If a result set which has two or more results of SELECT statement is returned from the database, then the following error occurs. A user can catch the error by using TOO\_MANY\_ROWS exception among predefined exceptions.

```

gSQL> CREATE TABLE T1
(
  C1 VARCHAR(20),
  C2 VARCHAR(20)
);
Table created.
gSQL> INSERT INTO T1 VALUES ('Seoul', '24');
1 row created.
gSQL> INSERT INTO T1 VALUES ('Pusan', '44');
1 row created.
gSQL> DECLARE
  v1 VARCHAR(20);
  v2 VARCHAR(20);

```

```

BEGIN
  BEGIN
    SELECT * INTO V1, V2 FROM T1;
  EXCEPTION WHEN TOO_MANY_ROWS
    THEN DBMS_OUTPUT.PUT_LINE( 'SQLCODE=' || SQLCODE);
    DBMS_OUTPUT.PUT_LINE( 'SQLERRM=' || SQLERRM);
  END;
END;
/
SQLCODE=-16289
SQLERRM=[SUNJESOFT][PSM][GOLDILOCKS]into clause can have only one row
Anonymous PL block executed.

```

If a result does not exist in SELECT INTO, then an error occurs. A user can catch the error by using NO\_DATA\_FOUND exception among predefined exceptions.

```

DECLARE
  V1 T1%ROWTYPE;
BEGIN
  SELECT * INTO V1 FROM T1 WHERE C1 = 'NONE';
END;
/
ERR-HY000(17041): execution fail :
  SELECT * INTO V1 FROM T1 WHERE C1 = 'NONE';
  *
ERROR at line 4:
ERR-HY000(17045): no data found

```



If a result of SELECT INTO statement is stored through a record type in GOLDILOCKS, it can not be used by mixing together with a different type variable. If they are used being mixed together, the following error may occur.

```

DECLARE
  TYPE rec is RECORD (F1 INTEGER, F2 INTEGER );
  var1 rec;
  v1 integer;
BEGIN
  DBMS_OUTPUT.PUT_LINE( 'Var1.f1 =[ ' || Var1.f1 || ' ]');
  DBMS_OUTPUT.PUT_LINE( 'Var1.f2 =[ ' || Var1.f2 || ' ]');
  SELECT 1, 2, 3 INTO Var1, v1 FROM DUAL;

```

```

DBMS_OUTPUT.PUT_LINE( 'Var1.f1 = ' || Var1.f1);
DBMS_OUTPUT.PUT_LINE( 'Var1.f2 = ' || Var1.f2);
END;
/
ERR-HY000(17032): PSM compilation error :
(1) at (9:29): ERR-HY000(17046): variables of record type can not be mixed with other
variables

```

However, it can be used as follows when a user uses a partial field of a record type by mixing with the SQL data type variable.

```

gSQL> CREATE TABLE T1
(
  C1 VARCHAR(20),
  C2 VARCHAR(20)
);
Table created.
gSQL> INSERT INTO T1 VALUES ('Seoul', '24');
1 row created.
gSQL> INSERT INTO T1 VALUES ('Pusan', '44');
1 row created.
gSQL> DECLARE
  v1 t1%ROWTYPE;
  v2 VARCHAR(20);
BEGIN
  SELECT * INTO V1.C1, V2 FROM T1
  WHERE C1 = 'Seoul';

```

- A value is not stored in V1.c2.

```

DBMS_OUTPUT.PUT_LINE('V1.c1 = ' || V1.C1 || ' , V1.c2 = ' || V1.C2);
DBMS_OUTPUT.PUT_LINE('V2 = ' || V2);
END;
/
V1.c1 = Seoul , V1.c2 =
V2 = 24
Anonymous PL block executed.

```

## INSERT

An INSERT statement in PSM provides the following expansion features.

- It can store the data in the database by using a user defined record type variable.
- It can store the data in RETURNING INTO clause by using a record type variable.

In PSM, it can inserts the data in the following form through a record type variable.

```
INSERT INTO table_name VALUES record_type_variable
```

For more information, refer to **Inserting Data**.

The following is an example of storing the record in the database by using PSM variable declared as an SQL data type.

```
gSQL>
CREATE TABLE T1
(
  C1 INTEGER,
  C2 INTEGER
);
Table created.
gSQL>
DECLARE
  V1 INTEGER;
  V2 INTEGER;
BEGIN
  V1 := 10;
  V2 := 20;

  INSERT INTO T1 (C1, C2) VALUES (V1, V2);
  COMMIT;
END;
/
Anonymous PL block executed.
gSQL> SELECT * FROM T1;
C1 C2
-- --
10 20
1 row selected.
```

The following is an example of inserting which uses a record type variable declared with %ROWTYPE.

```
gSQL>
CREATE TABLE T1
(
  C1 INTEGER,
  C2 INTEGER
);
Table created.
gSQL>
DECLARE
  V1 T1%ROWTYPE;
BEGIN
  V1.C1 := 10;
  V1.C2 := 20;

  INSERT INTO T1 VALUES V1;
  COMMIT;
END;
/
Anonymous PL block executed.
gSQL> SELECT * FROM T1;
C1 C2
-- --
10 20
1 row selected.
```

For more information, refer to **%ROWTYPE**.

The following is an example of storing the record in the database by using a user defined record type variable.

```
gSQL>
CREATE TABLE T1
(
  C1 INTEGER,
  C2 INTEGER
);
Table created.
gSQL>
DECLARE
  TYPE rec IS RECORD (F1 INTEGER, F2 INTEGER);
```

```

v1 rec;
BEGIN
  V1.F1 := 10;
  V1.F2 := 20;

  INSERT INTO T1 VALUES V1;
  COMMIT;
END;
/
Anonymous PL block executed.
gSQL> SELECT * FROM T1;
C1 C2
-- --
10 20
1 row selected.

```

For more information, refer to [User Defined Record Type](#).



If a record type variable is specified in a form other than PSM insert expansion, then the following error occurs.

```

gSQL>
DECLARE
  TYPE rec IS RECORD (F1 INTEGER, F2 INTEGER);
  v1 rec;
  v2 INTEGER;
BEGIN
  V1.F1 := 10;
  V1.F2 := 20;
  V2 := 30;

  INSERT INTO T1 (c1, c2) VALUES (V1);
  COMMIT;
END;
/
ERR-HY000(17032): PSM compilation error :
(1) at (11:3): ERR-42000(16053): not enough values

```

In the example above, two columns are listed and a variable of a specified VALUES clause is one. Though it is a record type variable, but the number of values to be bound is different, so an error occurs as above.

To use a variable by mixing with a type different from a record type, then it should be specified in a scalar type as follows.

```

gSQL>
DECLARE
  TYPE rec IS RECORD (F1 INTEGER, F2 INTEGER);
  v1 rec;
  v2 INTEGER;
BEGIN
  V1.F1 := 10;
  V1.F2 := 20;
  V2 := 30;

  INSERT INTO T1 (c1, c2) VALUES (V1.F1, V2);
  COMMIT;
END;
/
Anonymous PL block executed.
gSQL> SELECT * FROM T1;
C1 C2
-- --
10 30
1 row selected.

```

## UPDATE

The followings are features expanded from PSM.

- It can alter the database value to a value in a record type variable by using SET ROW clause.
- It can store the value of before/ after the alteration as a PSM variable through RETURNING INTO clause.

A record type variable can be used in the following form through an UPDATE expansion feature within PSM.

```
UPDATE table_list SET ROW = Record_type_variable [WHERE condition]
```

For more information, refer to **Updating Data**.

The following is an example of altering the record through a PSM record type variable and UPDATE ... SET ROW clause.

```

gSQL> CREATE TABLE T1
(
  C1 INTEGER,
  C2 INTEGER
);
Table created.
gSQL> INSERT INTO T1 VALUES (1, 1);
1 row created.
gSQL> DECLARE
  V1 T1%ROWTYPE;
BEGIN
  V1.C1 := 10;
  V1.C2 := 20;

  UPDATE T1 SET ROW = V1 WHERE c1 = 1;
  COMMIT;
END;
/
Anonymous PL block executed.
gSQL> SELECT * FROM T1;
C1 C2
-- --
10 20
1 row selected.

```

## DELETE

An expansion feature of PSM DELETE is as follows.

- It can store the deleted value as a record type variable through RETURNING INTO.

The following is an example of performing DELETE through PSM variable of SQL data type.

```

gSQL> CREATE TABLE T1
(
  C1 INTEGER,
  C2 INTEGER
);
Table created.
gSQL> INSERT INTO T1 VALUES (1, 1);

```



```
1 row created.
gSQL> DECLARE
  V1 INTEGER;
BEGIN
  V1 := 1;

  DELETE FROM T1 WHERE C1 = V1;
  COMMIT;
END;
/
Anonymous PL block executed.
gSQL> SELECT * FROM T1;
no rows selected.
```

## RETURNING INTO

It can store the result of processing DML (INSERT, UPDATE, DELETE) as a PSM variable by using RETURNING INTO clause.

- It has following restrictions when storing the result in RETURNING INTO of PSM.
  - The result returned to the database can be stored only in a single row. (Two or more results can not be stored.)
  - It can not be used together with a different type variable when storing as a record type variable.

## INSERT RETURNING INTO

INSERT RETURNING INTO clause stores the result value stored in the database as a PSM variable specified in RETURNING INTO clause.

The following is an example of storing the result of performing *insert* in a PSM variable.

```
gSQL>
DECLARE
  v1 INTEGER;
  v2 INTEGER;
  v3 INTEGER;
  v4 INTEGER;
BEGIN
  V1 := 10;
  V2 := 20;
```

```

INSERT INTO T1 (c1, c2) VALUES (V1, V2)
RETURNING * INTO V3, V4;
DBMS_OUTPUT.PUT_LINE( 'V3 = ' || V3 );
DBMS_OUTPUT.PUT_LINE( 'V4 = ' || V4 );
END;
/
V3 = 10
V4 = 20

```

The following is an example storing the result of a *returning into* by using a record type variable.

```

gSQL>
DECLARE
  v1 INTEGER;
  v2 INTEGER;
  v3 T1%ROWTYPE;
BEGIN
  V1 := 10;
  V2 := 20;

  INSERT INTO T1 (c1, c2) VALUES (V1, V2)
  RETURNING * INTO V3;
  DBMS_OUTPUT.PUT_LINE( 'V3.C1 = ' || V3.C1 );
  DBMS_OUTPUT.PUT_LINE( 'V3.C2 = ' || V3.C2 );
END;
/
V3.C1 = 10
V3.C2 = 20
Anonymous PL block executed.

```

## UPDATE RETURNING INTO

UPDATE RETURNING INTO can store the result before/ after the alteration in the database through a PSM variable specified in RETURNING INTO clause.

It stores the result of RETURNING INTO through an SQL type variable as follows.

```

gSQL> CREATE TABLE T1
(
  C1 INTEGER,
  C2 INTEGER

```

```

);
Table created.
gSQL> INSERT INTO T1 VALUES (1, 1);
1 row created.
gSQL> DECLARE
  V1 INTEGER;
  V2 INTEGER;
  V3 INTEGER;
  V4 INTEGER;
BEGIN
  V1 := 1;
  V2 := 2;

```

- It stores the result of when before it is altered by UPDATE in V3 and variable V3.

```

UPDATE T1 SET C2 = V2 WHERE C1 = V1
RETURNING OLD * INTO V3, V4;
DBMS_OUTPUT.PUT_LINE('OLD');
DBMS_OUTPUT.PUT_LINE('V3 = ' || V3);
DBMS_OUTPUT.PUT_LINE('V4 = ' || V4);
ROLLBACK;

```

- It stores the result of when after it is altered by UPDATE in V3 and variable V3.

```

UPDATE T1 SET C2 = V2 WHERE C1 = V1
RETURNING NEW * INTO V3, V4;
DBMS_OUTPUT.PUT_LINE('NEW');
DBMS_OUTPUT.PUT_LINE('V3 = ' || V3);
DBMS_OUTPUT.PUT_LINE('V4 = ' || V4);
END;
/
OLD
V3 = 1
V4 = 1
NEW
V3 = 1
V4 = 2
Anonymous PL block executed.

```

The following is an example of storing the result of RETURNING INTO by using a record type variable.

```

gSQL> CREATE TABLE T1
(
  C1 INTEGER,
  C2 INTEGER
);
Table created.
gSQL> INSERT INTO T1 VALUES (1, 1);
1 row created.
gSQL> DECLARE
  V1 INTEGER;
  V2 INTEGER;
  V3 T1%ROWTYPE;
BEGIN
  V1 := 1;
  V2 := 2;

```

- Store the result in a record type variable (V3).

```

UPDATE T1 SET C2 = V2 WHERE C1 = V1
RETURNING OLD * INTO V3;
DBMS_OUTPUT.PUT_LINE('OLD');
DBMS_OUTPUT.PUT_LINE('V3.C1 = ' || V3.C1);
DBMS_OUTPUT.PUT_LINE('V3.C2 = ' || V3.C2);
ROLLBACK;

```

- Store the result in a record type variable (V3).

```

UPDATE T1 SET C2 = V2 WHERE C1 = V1
RETURNING NEW * INTO V3;
DBMS_OUTPUT.PUT_LINE('NEW');
DBMS_OUTPUT.PUT_LINE('V3.C1 = ' || V3.C1);
DBMS_OUTPUT.PUT_LINE('V3.C2 = ' || V3.C2);
END;
/
OLD
V3.C1 = 1
V3.C2 = 1
NEW
V3.C1 = 1
V3.C2 = 2
Anonymous PL block executed.

```

## DELETE RETURNING INTO

DELETE RETURNING INTO can store the data of a row deleted from the database in a PSM variable.

The following is an example of using SQL type variables.

```
gSQL> CREATE TABLE T1
(
  C1 INTEGER,
  C2 INTEGER
);
Table created.
gSQL> INSERT INTO T1 VALUES (1, 1);
1 row created.
gSQL> DECLARE
  V1 INTEGER;
  V2 INTEGER;
  V3 INTEGER;
BEGIN
  V3 := 1;
```

- Store the data of when before DELETE in the variable V1 and V2.

```
DELETE FROM T1 WHERE C1 = V3
RETURNING * INTO V1, V2;
DBMS_OUTPUT.PUT_LINE('V1 = ' || V1 );
DBMS_OUTPUT.PUT_LINE('V2 = ' || V2 );
END;
/
V1 = 1
V2 = 1
Anonymous PL block executed.
```

The following is an example of storing the data of when before DELETE through a record type variable.

```
gSQL> CREATE TABLE T1
(
  C1 INTEGER,
  C2 INTEGER
);
Table created.
gSQL> INSERT INTO T1 VALUES (1, 1);
```

```

1 row created.
gSQL> DECLARE
  V1 T1%ROWTYPE;
  V3 INTEGER;
BEGIN
  V3 := 1;

```

- Store the data of when before DELETE in the variable V3.

```

DELETE FROM T1 WHERE C1 = V3
RETURNING * INTO V1;
DBMS_OUTPUT.PUT_LINE('V1.C1 = ' || V1.C1 );
DBMS_OUTPUT.PUT_LINE('V1.C2 = ' || V1.C2 );
END;
/
V1.C1 = 1
V1.C2 = 1
Anonymous PL block executed.

```

## COMMIT, ROLLBACK, SAVEPOINT

COMMIT, ROLLBACK, SAVEPOINT statements permanently store the transaction result which occurred within PSM in the database, or rolls back it to the state of when before the alteration.

### COMMIT

COMMIT permanently stores the transaction result in the database. It is used as follows.

```

CREATE TABLE T1
(
  C1 INTEGER,
  C2 INTEGER
);
Table created.
INSERT INTO T1 VALUES (1, 1);
1 row created.
DECLARE
  V3 INTEGER;
BEGIN
  V3 := 1;

```

```

DELETE FROM T1 WHERE C1 = V3;
COMMIT;
END;
/
Anonymous PL block executed.
SELECT * FROM T1;
no rows selected.

```

## ROLLBACK

ROLLBACK rolls back the transaction to its previous state. It is used as follows.

```

gSQL> CREATE TABLE T1
(
  C1 INTEGER,
  C2 INTEGER
);
Table created.
gSQL> INSERT INTO T1 VALUES (1, 1);
1 row created.
gSQL> COMMIT;
Commit complete.
gSQL> DECLARE
  V3 INTEGER;
BEGIN
  V3 := 1;

  DELETE FROM T1 WHERE C1 = V3;
  ROLLBACK;
END;
/
Anonymous PL block executed.

```

- Verify if the DELETE ROLLBACK data is normally retrieved in PSM.

```

gSQL> SELECT * FROM T1;
C1 C2
-- --
1  1
1 row selected.

```

## SAVEPOINT

SAVEPOINT rolls back a transaction to the user defined location by using ROLLBACK TO SAVEPOINT statement.

```
gSQL> CREATE TABLE T1
(
  C1 INTEGER,
  C2 INTEGER
);
Table created.
gSQL> INSERT INTO T1 VALUES (1, 1);
1 row created.
gSQL> DECLARE
  V1 INTEGER;
BEGIN
  UPDATE T1 SET C2 = 10 WHERE C1 = 1;
  SELECT C2 INTO V1 FROM T1 WHERE C1 = 1;
  DBMS_OUTPUT.PUT_LINE('Before delete: V1 = ' || V1 );
```

- Assign the current location as a SAVEPOINT.

```
SAVEPOINT SV1;
DELETE FROM T1 WHERE C1 = 1;
```

- ROLLBACK it to the savepoint SV1.

```
ROLLBACK TO SAVEPOINT SV1;
```

- Verify if it is normally ROLLBACK to the SAVEPOINT.

```
SELECT C2 INTO V1 FROM T1 WHERE C1 = 1;
DBMS_OUTPUT.PUT_LINE('After Rollback: V1 = ' || V1 );
END;
/
Before delete: V1 = 10
After Rollback: V1 = 10
Anonymous PL block executed.
```



## 26.2 Dynamic SQL

Unlike a static SQL, the syntax of a dynamic SQL is determined at the time of execution.

In PSM, a dynamic SQL created by a user at run-time can be performed through EXECUTE IMMEDIATE or OPEN FOR statement.

- A dynamic SQL is used in the following cases.
  - When an SQL statement can not be determined when compiling. (e.g. When an SQL statement should be altered according to conditions.)
  - When an SQL which is not supported in a static SQL is performed. (e.g. DDL)
- The syntax of a dynamic SQL is unknown until the time of execution, so a run-time error may occur due to a syntax error, existence of a target object and validation of a user privilege.
- A dynamic SQL can be used in the following PSM statements.
  - **EXECUTE IMMEDIATE Statement**
  - **OPEN FOR Statement**

### EXECUTE IMMEDIATE

Various dynamic SQLs can be performed in EXECUTE IMMEDIATE. However, a statement in a form of an SQL extension provided by PSM can not be used.

The statement is provided in the following form.

```
EXECUTE IMMEDIATE 'dynamic sql' [ USING [IN | OUT | INOUT] variable_list] [INTO variable_list]
[RETURNING INTO variable_list]
```

A value stored in a PSM variable can be applied to a database through USING, INTO, RETURNING INTO statements which are provided to an EXECUTE IMMEDIATE statement, or a value can be stored from a database to a PSM variable. The differences of using each statement are as follows.

- USING
  - It uses an IN-mode when applying a value of PSM variable to an SQL.
  - It uses an OUT-mode when storing the result of SQL processing in a PSM variable.
    - Therefore, if uses an OUT-mode, it should be described with PSM variables. (An expression is not available.)
  - An IN-mode is applied when a binding type of the variable specified in USING clause is not specified.
  - It is operated as same as using SELECT INTO clause when a target of SELECT is returned as USING OUT.

- Only a single row can be returned from the database. If two or more results occurs then an error occurs.
- A PSM variable in a USING IN clause can use only a form of scalar type.
- A PSM variable in a USING OUT clause can use a record type, but it can not use it by mixing with another type.
- INTO
  - It is used when storing the result of SELECT which is internally processed in a database using an implicit cursor.
  - It can be used only when executing SELECT clause using a dynamic SQL method. (SELECT INTO clause can not be used.)
  - A PSM variable can be a record-type, but it can not be used by mixing with another type.
- RETURNING INTO
  - It is used when storing the before/ after of the data processed by INSERT/ UPDATE/ DELETE.
  - It can store only a single row.
  - A PSM variable can be a record-type, but it can not be used by mixing with another type.

The following is an example of outputting the SELECT INTO statement result by using a dynamic SQL.

```

gSQL> CREATE TABLE T1
(
  C1 VARCHAR(20),
  C2 VARCHAR(20)
);
Table created.
gSQL> INSERT INTO T1 VALUES ('Seoul', '24');
1 row created.
gSQL> INSERT INTO T1 VALUES ('Pusan', '44');
1 row created.
gSQL> DECLARE
  V1 VARCHAR(20);
  V2 VARCHAR(20);
BEGIN
  EXECUTE IMMEDIATE 'SELECT * INTO ?, ? FROM T1 WHERE C1 = ''Seoul'''
  USING OUT V1, OUT V2;
  DBMS_OUTPUT.PUT_LINE('V1 = ' || V1);
  DBMS_OUTPUT.PUT_LINE('V2 = ' || V2);
END;
/
V1 = Seoul
V2 = 24
Anonymous PL block executed.
```

The following is an example of performing an altering operation and storing the result of when before the alteration in a variable specified in RETURNING INTO.

```

gSQL> CREATE TABLE T1
(
  C1 VARCHAR(20),
  C2 VARCHAR(20)
);
Table created.
gSQL> INSERT INTO T1 VALUES ('Seoul', '24');
1 row created.
gSQL> INSERT INTO T1 VALUES ('Pusan', '44');
1 row created.
gSQL> DECLARE
  V1 VARCHAR(20);
  V2 VARCHAR(20);
  V3 VARCHAR(20);
  V4 VARCHAR(20);
BEGIN
  V1 := 'Daegu';
  V2 := '50';
  EXECUTE IMMEDIATE
    'UPDATE T1 SET C1 = ? , C2 = ? WHERE C1 = ''Seoul'' RETURNING OLD * INTO ?, ?'
  USING V1, V2 RETURNING INTO V3, V4;
  DBMS_OUTPUT.PUT_LINE('V3 = ' || V3);
  DBMS_OUTPUT.PUT_LINE('V4 = ' || V4);
END;
/
V3 = Seoul
V4 = 24
Anonymous PL block executed.

```

For more information, refer to [EXECUTE IMMEDIATE Statement](#).

## OPEN FOR, FETCH and CLOSE

When processing a query by using EXECUTE IMMEDIATE, the database can not return one or more results. If an SQL to be processed is a dynamic SQL, and two or more result sets should be fetched, like as a cursor, then use OPEN FOR.

The a dynamic SQL in the following form can be used in OPEN FOR statement.

```
OPEN Cursor_variable FOR dynamic_sql [USING variable_list]
```

The following is an example of performing OPEN FOR statement through a dynamic SQL.

```
gSQL> CREATE TABLE T1
(
  C1 VARCHAR(20),
  C2 VARCHAR(20)
);
Table created.
gSQL> INSERT INTO T1 VALUES ('Seoul', '24');
1 row created.
gSQL> INSERT INTO T1 VALUES ('Pusan', '44');
1 row created.
gSQL> DECLARE
  v1 VARCHAR(20);
  v2 VARCHAR(20);
  v3 VARCHAR(20);
  cv1 SYS_REFCURSOR;
  sqlstr VARCHAR(1024);
BEGIN

  sqlstr := 'SELECT * FROM T1 WHERE C1 >= ?';
  v3 := 'AAAA';
  OPEN cv1 FOR sqlstr USING v3;
  FETCH cv1 INTO v1, v2;
  DBMS_OUTPUT.PUT_LINE('V1 = ' || v1 || ' , V2 = ' || v2);
  CLOSE cv1;
END;
/
V1 = Seoul , V2 = 24
Anonymous PL block executed.
```

- USING clause in OPEN FOR statement has the following constraints.
  - Binding mode
    - Only IN mode is available.
  - Available items
    - PSM variable
    - Value expression whose result is returned as a scalar type

For more information, refer to **OPEN FOR Statement**, **FETCH Statement**, **CLOSE Statement**.



**27.**

---

## **PSM Packages**

This chapter describes how to modularize common data and PSM codes used in various applications into the package.

## 27.1 Definition

A package is a schema object which bundles items such as logically-related PSM types, variables, subprograms, cursors and exceptions. A package is stored in the database through the compiling process, so that another program (another package, procedure, external program) may refer, share and execute the items in the package.

Every package has a specification in which referable multiple public items and subprograms are listed. If a cursor exists among public items or a public subprogram exists, then the package may have a package body. The body includes the following contents.

- SQL statement to be performed by a public cursor, or PSM code which is to be executed by a public subprogram
- Items such as multiple variables and types subprograms which are private and used only internally
- Code for initializing public items (initialization part) which is performed only once when the package is used for the first time (instantiation).

AUTHID statement of the package specification determines whether to perform the package with an invoker privilege or with a definer privilege (Default: definer). It also determines whether to translate the unqualified object in the invoker or in the definer when referring to it.

Only the package owner and the user with EXECUTE PACKAGE privilege can retrieve the definition statement of package specification. However, only the package owner can retrieve the definition statement of package body.

## 27.2 Features

The following features of package provides an application developer and an operator with high reliability and reusability.

- Modularity
  - It bundles related items and subprograms together, so it is easy to manage the database and understand its structure.



- Easy programming
  - A user can program the related application only by defining a specification even without defining the body.
- Encapsulating
  - It can hide the body contents which is an internal implementation of the package from the package user.
  - It can alter the body (implementation) without recompiling SQL and application which use the package.
- Performance optimization
  - The entire package is loaded on the memory at once, so that it can quickly call the subprogram in the memory.
- Easy privilege control
  - It can bundle all separate privileges for using all public items and subprograms into a single privilege for the entire package.

A package does not support a subprogram overloading, so functions of the same names can not be defined in the same block scope.

## 27.3 Specification

The following public items can be declared in the package specification.

- User-defined type
  - Record or collection (Associative array)
  - A user-defined type declared in a package can be used only in a PSM-family statement.
- Variable
  - It is recommended to define a get/ set subprogram for each variable not to directly refer to the variable.
- Subprogram
  - Procedure
  - Function
- Explicit cursor
  - It is allowed to define only a name and a returned type in a package specification and define SQL statement performed by a cursor in a body.
  - A cursor variable can not be defined with a public item in a package.
- User-defined exception

## Creating Package Specification

Create a package specification by using CREATE PACKAGE statement.

```
CREATE OR REPLACE PACKAGE MY_PKG
IS
  TYPE MY_REC IS RECORD (F1 INTEGER, F2 INTEGER );
END;
/
```

Package created.

Public items in a defined package can be referred from outside of a package by specifying the package name together as follows.

```
DECLARE
V1 MY_PKG.MY_REC;
BEGIN
  V1.F1 := 10;
  V1.F2 := 20;
  DBMS_OUTPUT.PUT_LINE( 'V1.F1 = ' || V1.F1 || ', V1.F2 = ' || V1.F2 );
END;
/
```

```
V1.F1 = 10, V1.F2 = 20
```

Anonymous PL block executed.

## Creating Package Body

The body should be declared when a public cursor or subprogram exists in a package, or the initialization code is required. Otherwise, body definition is optional.

The package body has the following constraints.

- The package body should be created in the schema which is as same as that of the package specification.
- The package body should have the name as same as that of the package specification.
- If a cursor in which the SQL statement is not defined exists among open cursors declared in a package specification, then the cursor with the same name, record type and argument should be declared by specifying SQL in the body.
- A subprogram whose name, argument and return type are same as those of an open subprogram declared in a package specification should be defined in the body.

- The variable, type, exception which are as same as those defined in a package specification can not be declared in the package body.

Create a package body as follows.

```

CREATE TABLE emp( empno NUMBER, sal NUMBER, comm NUMBER );
Table created.
INSERT INTO emp VALUES( 3548, 6000, 1000 );
1 row created.
INSERT INTO emp VALUES( 9369, 5000, NULL );
1 row created.
INSERT INTO emp VALUES( 7294, 4000, 500 );
1 row created.
COMMIT;
Commit complete.
CREATE OR REPLACE PACKAGE emp_mgmt
IS
  PROCEDURE adjust_sal(v_flag VARCHAR, v_empno NUMBER, v_pct NUMBER);
  FUNCTION get_annual_sal(v_empno NUMBER) RETURN NUMBER;
END;
/
Package created.
CREATE OR REPLACE PACKAGE BODY emp_mgmt
IS
  PROCEDURE adjust_sal(v_flag VARCHAR, v_empno NUMBER, v_pct NUMBER) IS
  BEGIN
    IF v_flag = 'INCREASE' THEN
      UPDATE emp SET sal = sal + (sal * (v_pct / 100)) WHERE empno = v_empno;
    ELSE
      UPDATE emp SET sal = sal - (sal * (v_pct / 100)) WHERE empno = v_empno;
    END IF;
  END;
END;
FUNCTION get_annual_sal (v_empno NUMBER) RETURN NUMBER
IS
  v_sal NUMBER;
BEGIN
  SELECT (sal + NVL(comm,0)) * 12 INTO v_sal FROM emp WHERE empno = v_empno;
  RETURN v_sal;
END;
END;
/
Package created.

```

Call subprograms of the created package body as follows.

```
call emp_mgmt.adjust_sal('INCREASE',7369, 10);
Procedure Call complete.
SELECT emp_mgmt.get_annual_sal(7294) FROM DUAL;
EMP_MGMT.GET_ANNUAL_SAL(7294)
-----
                               54000
1 row selected.
```

## Package State

Packages are classified into a stateful package and a stateless package.

A stateful package includes one or more variables or cursors, and a stateless package is configured with subprograms only such as a procedure or a function.

A stateful package creates a package instance in a session when referring to the variable or the cursor of the package for the first time. In this case, it performs the following operations.

- Initialize a package variable
- Execute an initialize section

Generally, a package state is maintained as same as the lifetime of a session. However, a stateful package is invalidated and an instance is initialized in the following cases.

- When the package is recreated by executing REPLACE PACKAGE statement
- When the package is recompiled by executing ALTER PACKAGE statement
- When altering operation (DDL) which affects the package instance form occurs on any object which was referenced by the package.

A stateless package does not have a state, so it is automatically recompiled even when the related object's form is altered. However, a stateful package drops the existing package instance, then it recreates a package instance based on the updated package information.

Therefore, be cautious to handle the situational exception when using a package in an application.

**28.**

---

## **PSM Language Element References**

## 28.1 Assignment Statement

### Function

Within a PSM block, it stores a value in a variable or in an out-bind parameter.

### Syntax

```
<assignment statement> ::=  
    <assignment target> := <value expression>  
    ;  
<assignment target> ::=  
    collection_variable ( index )  
    | cursor_variable  
    | :host_cursor_variable  
    | out_parameter  
    | :host_variable [ :indicator_variable ]  
    | record_variable . field_name  
    | scalar_variable
```

### Invocation and Access Rules

It can be used only within PSM. (e.g. package, procedure, function)

It can be used only in the body section of a PL block.

### Syntax Rules and Parameters

- collection\_variable
  - It is the variable name of COLLECTION type declared in DECLARE section.
- index
  - It is the key value which selects an element among elements of collection\_variable.
- cursor\_variable
  - It is the cursor name declared in DECLARE section.
- host\_variable

- It is the name of out/ in-out type client-side variable which is transferred from where calling PSM.
- `indicator_variable`
  - It is the indicator variable name to check the NULL value of `host_variable` and to find out the actual length of the value.
- `record_variable`
  - It is the variable name of RECORD type which has already been declared in DECLARE section.
- `field_name`
  - It is the name of a field among fields included in a RECORD type variable.
- `scalar_variable`
  - It is the variable name of a general scalar type which has already been declared in DECLARE section.

## Description

Targets of assignment statements are classified into an external bind parameter and an internal PSM variable.

- External parameter
  - Host variable
  - Host cursor variable
- Internal variable
  - Out type function argument
  - Internally declared variable
    - Scalar/ record/ multi-set type
    - A specific field of a record type variable
    - A specific element of multi-set type variable

All variables except for a procedure/ function parameter can have a name assigning a scope.

## Examples

The following is an example of using an assignment statement.

- Assignment for PSM internal variable

```
gSQL> DECLARE
  V1 INTEGER := 0;
BEGIN
  FOR I IN 1..10 LOOP
```

```

    V1 := V1 + I;
END LOOP;
DBMS_OUTPUT.PUT_LINE( 'V1 = ' || V1 );
END;
/
V1 = 55
Anonymous PL block executed.

```

- Assignment for a host variable

```

gSQL> \var P1 INTEGER
gSQL>
BEGIN
  :P1 := 100;
END;
/
gSQL> \print P1
P1
---
100
Anonymous PL block executed.

```

## Compatibility

The differences between an assignment statement of GOLDILOCKS and that of SQL standard are as follows.

- An assignment statement of the SQL standard defines a singleton variable assignment and a multiple variable assignment, but GOLDILOCKS supports only a singleton variable assignment.
- An assignment statement of the SQL standard starts with SET keyword, but GOLDILOCKS does not use SET keyword.
- An assignment statement of the SQL standard uses an equal operator (=) between a target and a value, but GOLDILOCKS uses :=.

**Table 28-1** SQL standard compatibility

Feature ID	Description	Compatibility
P002	Computational completeness	X
P006	Multiple assignment	X



## For More Information

Refer to the followings.

- **Scalar Variable Declaration**
- **Record Variable Declaration**
- **COLLECTION Variable Declaration**
- **Cursor Variable Declaration**

## 28.2 Basic LOOP Statement

### Function

It repeatedly performs statements within LOOP until the LOOP is terminated by performing GOTO or EXIT.

### Syntax

```
<basic loop statement> ::=  
    LOOP { <SQL procedure statement> ; }... END LOOP [ loop_name ]  
    ;
```

### Invocation and Access Rules

It can be used only within PSM. (e.g. package, procedure, function)

It can be used only in the body section of a PL block.

### Syntax Rules and Parameters

- loop\_name
  - It is the label name of <basic loop statement>.
  - Its role is only a comment, so it does not matter even when it is different from the real label name of <basic loop statement>.

### Description

A basic loop statement is repeatedly performs statements within LOOP.

A basic loop statement is a loop-family statement, so it can be a target statement which GOTO, EXIT, and CONTINUE indicates as a label.

## Examples

```

DECLARE
  V1 INTEGER := 1;
BEGIN
  LOOP
    DBMS_OUTPUT.PUT_LINE( 'V1 = ' || V1 );
    V1 := V1 + 1;
    EXIT WHEN V1 > 2;
  END LOOP;
END;
/
V1 = 1
V1 = 2
Anonymous PL block executed.

```

## Compatibility

<basic loop statement> statement is as same as <loop statement> of the SQL standard.

**Table 28-2** SQL standard compatibility

Feature ID	Description	Compatibility
P002	Computational completeness	O

## For More Information

Refer to the followings.

- **CONTINUE Statement**
- **EXIT Statement**
- **GOTO Statement**

## 28.3 Block (BEGIN .. END)

### Function

It creates a new scope and defines a variable, a cursor, a type and an exception.

### Syntax

```

<PSM block> ::=
    [ DECLARE <declare item>... ] BEGIN <SQL procedure statement list> END
    ;
<declare item> ::=
    <variable declaration>
    | <explicit cursor declaration>
    | <explicit cursor definition>
    | <cursor variable declaration>
    | <type definition>
    | <exception declaration>
    | <exception init pragma>
    | <procedure declaration>
    | <procedure definition>
    | <function declaration>
    | <function definition>
<executable statement list> ::=
    [ <label list> ] { <SQL procedure statement> ; }...
<label list> ::=
    { << identifier >> }...
<SQL procedure statement>
    <PSM Static SQL>
    | <PSM Dynamic SQL>
    | <PSM Control Statement>

```

## Invocation and Access Rules

It can be used only within PROCEDURE, FUNCTION or an anonymous block.

## Syntax Rules and Parameters

- Variable declaration
  - It declares scalar/ record/ array type variables which are to be used in a block.
- Explicit cursor declaration
  - It declares cursors which are to to be used in a block.
- Explicit cursor definition
  - It defines cursors which are to be used in a block.
- Cursor variable declaration
  - It declares a cursor variable to be used in a block.
- Type definition
  - It defines user-defined types which are to be used when declaring variables in a block.
- Exception declaration
  - It defines exceptions to be used in a block.
- Exception init pragma
  - It sets the error code which is to be processed by a user-defined exception.
- Procedure declaration
  - It declares procedures to be used in a block.
- Procedure definition
  - It defines procedures to be used in a block.
- Function declaration
  - It declares functions to be used in a block.
- Function definition
  - It defines functions to be used in a block.
- Static SQL
  - It indicates Data Manipulation Language (DML) and Data Control Language (DCL) which can be performed in PSM.
- Dynamic SQL
  - It indicates statements related to dynamic query processing supported by GOLDILOCKS PSM.
- PSM Control Statement
  - It indicates various flow control statements supported by GOLDILOCKS PSM.

## Description

<psm block> is a basic component of PSM.

A block can have a declaration part and an exception handling part.

A block can be duplicated, and the duplicated block has a new subordinate variable scope. A superordinate block can not refer to a variable in a subordinate block.

## Examples

```
gSQL>
<<MAIN>>
DECLARE
  V1 INTEGER := 1;
BEGIN
  DBMS_OUTPUT.PUT_LINE( 'V1 = ' || V1 );
  <<SUB1>>
  DECLARE
    V1 VARCHAR(10) := 'ABC';
  BEGIN
    DBMS_OUTPUT.PUT_LINE( 'V1 = ' || V1 );
    DBMS_OUTPUT.PUT_LINE( 'SUB1.V1 = ' || SUB1.V1 );
    DBMS_OUTPUT.PUT_LINE( 'MAIN.V1 = ' || MAIN.V1 );
  END;
END;
/
V1 = 1
V1 = ABC
SUB1.V1 = ABC
MAIN.V1 = 1
Anonymous PL block executed.
```

## Compatibility

<compound statement> of the SQL standard defines ATOMIC /NOT ATOMIC statement which specifies a new savepoint, but GOLDLOCKS does not support it.

**Table 28-3** SQL standard compatibility

Feature ID	Description	Remarks
P002	Computational completeness	It does not support ATOMIC statement.

## For More Information

Refer to [Overview of PSM](#).

## 28.4 CASE Statement

### Function

It performs a statement list satisfying conditions which returns TRUE among given conditions.

### Syntax

```
<case statement> ::=
    <simple case statement>
    | <searched case statement>
    ;
<simple case statement> ::=
    CASE <case operand> <simple case statement when clause>...
    [ <case statement else clause> ]
    END CASE
<searched case statement> ::=
    CASE <searched case statement when clause>...
    [ <case statement else clause> ]
    END CASE
<simple case statement when clause> ::=
    WHEN <when operand>
        THEN <executable statement list>
<searched case statement when clause> ::=
    WHEN <search condition>
        THEN <executable statement list>
```

### Invocation and Access Rules

It can be used only within PSM. (e.g. package, procedure, function)

It can be used only in the body section of a PL block.



## Syntax Rules and Parameters

- Case operand
  - They are all expressions which can be evaluated with a scalar value.
  - However, it can not include a subquery statement.
- When operand
  - It is an expression to compare whether it is as same as <case operand>.
  - However, it can not include a subquery statement.
- Search condition
  - It is a conditional expression to be performed when the evaluation result of <searched case statement> is TRUE.
  - However, it can not include a subquery statement.
- Executable statement list
  - It is a list of all statements which can be performed within PSM.

## Description

It performs statements in WHEN clause returning TRUE by evaluating conditions like as IF statement. It evaluates conditional expressions in order, and stops evaluating after finding the TRUE conditional clause.

If the case satisfying the condition does not exist and ELSE clause is not specified, then an error occurs.

## Examples

### Using a Simple CASE

```
gSQL> DECLARE
V1 integer := 0;
BEGIN
  SELECT 2 INTO V1 FROM DUAL;
  CASE V1 WHEN 0 THEN DBMS_OUTPUT.PUT_LINE ('Result = 0');
          WHEN 1 THEN DBMS_OUTPUT.PUT_LINE ('Result = 1');
          WHEN 2 THEN DBMS_OUTPUT.PUT_LINE ('Result = 2');
          ELSE DBMS_OUTPUT.PUT_LINE ('Result = OTHER');
  END CASE;
END;
/
```

```
Result = 2
```

```
Anonymous PL block executed.
```

## Using a Searched CASE

```
gSQL> DECLARE
V1 integer := 0;
BEGIN
  SELECT 2 INTO V1 FROM DUAL;
  CASE WHEN V1 = 0 THEN DBMS_OUTPUT.PUT_LINE ('Result = 0');
        WHEN V1 = 1 THEN DBMS_OUTPUT.PUT_LINE ('Result = 1');
        WHEN V1 = 2 THEN DBMS_OUTPUT.PUT_LINE ('Result = 2');
        ELSE DBMS_OUTPUT.PUT_LINE ('Result = OTHER');
  END CASE;
END;
/
Result = 2
Anonymous PL block executed.
```

## Compatibility

CASE statement of the SQL standard defines the comparison of row type (list type) values, but GOLDILOCKS does not support it.

CASE statement of the SQL standard can define multiple conditions in a list in <when operand> by delimiting them with ',', but GODILOCKS does not support it.

**Table 28-4** SQL standard compatibility

Feature ID	Description	Remarks
P002	Computational completeness	It does not support P004, P008.
P004	Extended CASE statement	-
P008	Comma-separated predicates in simple CASE statement	-

## 28.5 CLOSE Statement

### Function

It closes an open cursor.

### Syntax

```
<close statement> ::=  
    CLOSE cursor_name  
    ;
```

### Invocation and Access Rules

It can be used only within PSM. (e.g. package, procedure, function)

It can be used only in the body section of a PL block.

### Syntax Rules and Parameters

- cursor\_name
  - It is the name of a cursor to be closed.

### Description

It closes an open cursor.

A closed cursor can be opened again by using an open statement.

## Examples

```
gSQL> CREATE TABLE T1 ( I1 INTEGER );  
Table created.  
gSQL> COMMIT;  
Commit complete.  
gSQL> DECLARE  
    CURSOR C1 IS SELECT I1 FROM T1;  
    V1 T1%ROWTYPE;  
BEGIN  
    OPEN C1;  
    FETCH C1 INTO V1;  
    CLOSE C1;  
END;  
/  
Anonymous PL block executed.
```

## Compatibility

The SQL standard does not define it.

## For More Information

Refer to the followings.

- [FETCH Statement](#)
- [OPEN Statement](#)

## 28.6 Collection Method Invocation

### Function

It provides a method which can explore a collection type variable.

### Syntax

```
<collection method> ::=
    variable_name . <method>
;
<method> ::=
    first ()
    | last ()
    | prior ( expression )
    | next ( expression )
    | count ()
    | exists ( expression )
    | delete ( expression )
```

### Invocation and Access Rules

It can be used only within PSM. (e.g. package, procedure, function)

It can be used only in the body section of a PL block.

### Syntax Rules and Parameters

- It can be used only in a variable declared as a collection type.
- FIRST, LAST, COUNT can not have a parameter.
- A parameter should be specified when an object should be specified such as PRIOR, NEXT, EXISTS, DELETE.
- DELETE is operated as same as PSM statement, and it can not return a different variable as a result. (It can not be used in an expression.)

## Description

Refer to the following table.

**Table 28-5** Function

Name	Function	Return value	Whether to require an argument
FIRST	It returns the smallest key.	A key type specified in INDEX OF	X
LAST	It returns the biggest key.	A key type specified in INDEX OF	X
PRIOR	It returns a key smaller than the input key.	A key type specified in INDEX OF	O
NEXT	It returns a key bigger than the input key.	A key type specified in INDEX OF	O
COUNT	It returns the stored count.	INTEGER	X
DELETE	It deletes a value corresponding to a key.	N/A	O
EXISTS	It returns whether a key exists or not.	BOOLEAN	O

## Examples

```

DECLARE
TYPE rec IS TABLE OF VARCHAR(20) INDEX BY VARCHAR(20);
v1 rec;
v2 VARCHAR(20);
BEGIN
  DBMS_OUTPUT.PUT_LINE( '-----');
  DBMS_OUTPUT.PUT_LINE( 'first = ' || v1.first);
  DBMS_OUTPUT.PUT_LINE( 'last = ' || v1.last);
  DBMS_OUTPUT.PUT_LINE( 'prior = ' || v1.prior('aaa'));
  DBMS_OUTPUT.PUT_LINE( 'next = ' || v1.next('aaa'));
  DBMS_OUTPUT.PUT_LINE( 'count = ' || v1.count());
  FOR I IN 1 .. 9
  LOOP
    v1('a' || to_char(i)) := 'a' || to_char(i);
  END LOOP;
  DBMS_OUTPUT.PUT_LINE( '-----');
  DBMS_OUTPUT.PUT_LINE( 'first = ' || v1.first);
  DBMS_OUTPUT.PUT_LINE( 'last = ' || v1.last);
  DBMS_OUTPUT.PUT_LINE( 'count = ' || v1.count());
  DBMS_OUTPUT.PUT_LINE( '-----');

```

```

DBMS_OUTPUT.PUT_LINE( 'Print all from first to last');
v2 := v1.first;
WHILE v2 IS NOT NULL
LOOP
    DBMS_OUTPUT.PUT_LINE('Key= ' || v2 || ',Value=' || v1(v2));
    v2 := v1.next(v2);
END LOOP;
DBMS_OUTPUT.PUT_LINE( '-----');
DBMS_OUTPUT.PUT_LINE( 'Print all from last to first');
v2 := v1.last;
WHILE v2 IS NOT NULL
LOOP
    DBMS_OUTPUT.PUT_LINE('Key= ' || v2 || ',Value=' || v1(v2));
    v2 := v1.prior(v2);
END LOOP;
v1.delete(v1.first());
DBMS_OUTPUT.PUT_LINE('count = ' || v1.count() );
DBMS_OUTPUT.PUT_LINE('first = ' || v1.first() );
END;
/
-----

first =
last =
prior =
next =
count = 0
-----

first = a1
last = a9
count = 9
-----

Print all from first to last
Key= a1,Value=a1
Key= a2,Value=a2
Key= a3,Value=a3
Key= a4,Value=a4
Key= a5,Value=a5
Key= a6,Value=a6
Key= a7,Value=a7
Key= a8,Value=a8
Key= a9,Value=a9

```

---

```
Print all from last to first
```

```
Key= a9,Value=a9
```

```
Key= a8,Value=a8
```

```
Key= a7,Value=a7
```

```
Key= a6,Value=a6
```

```
Key= a5,Value=a5
```

```
Key= a4,Value=a4
```

```
Key= a3,Value=a3
```

```
Key= a2,Value=a2
```

```
Key= a1,Value=a1
```

```
count = 8
```

```
first = a2
```

```
Anonymous PL block executed.
```

## For More Information

Refer to [COLLECTION Variable Declaration](#).



## 28.7 COLLECTION Variable Declaration

### Function

It declares a collection variable.

### Syntax

```

<declare record variable> ::=
    variable_name <collectionType>
    ;

<Collection Type Definition> ::=
    TYPE <Type-Name> IS TABLE OF <Element-Type> INDEX BY <Index-Type>
    ;

<Element-Type> ::=
    Built-in SQL Data Type
    | User-Defined Type
    | %TYPE
    | %ROWTYPE

<Index-Type> ::=
    INTEGER
    | LONG
    | CHAR(n)
    | VARCHAR(n)
  
```

### Invocation and Access Rules

It can be used only within PSM. (e.g. package, procedure, function)

It can be used only in the declaration section of a PL block.

## Syntax Rules and Parameters

- Type-name
  - It specifies the name of a collection type to be used by a user.
- Element-type
  - It specifies the type of an element to be stored in a collection variable.
- Index-type
  - It specifies the data type of a key stored in a collection variable.

## Description

It declares a collection type.

## Examples

```
gSQL> DECLARE
TYPE rec IS TABLE OF VARCHAR(20) INDEX BY VARCHAR(20);
v1 rec;
v2 VARCHAR(20);
BEGIN
  DBMS_OUTPUT.PUT_LINE( 'first = ' || v1.first);
  DBMS_OUTPUT.PUT_LINE( 'last = ' || v1.last);
  DBMS_OUTPUT.PUT_LINE( 'prior = ' || v1.prior('aaa'));
  DBMS_OUTPUT.PUT_LINE( 'next = ' || v1.next('aaa'));
  DBMS_OUTPUT.PUT_LINE( 'count = ' || v1.count());
  FOR I IN 1 .. 10
  LOOP
    v1('a' || i) := 'a' || i;
  END LOOP;
  DBMS_OUTPUT.PUT_LINE( 'first = ' || v1.first);
  DBMS_OUTPUT.PUT_LINE( 'last = ' || v1.last);
  DBMS_OUTPUT.PUT_LINE( 'count = ' || v1.count());
  DBMS_OUTPUT.PUT_LINE( 'Print all from first to last');
  v2 := v1.first;
  WHILE v2 IS NOT NULL
  LOOP
    DBMS_OUTPUT.PUT_LINE('Key= ' || v2 || ',Value=' || v1(v2));
```

```
        v2 := v1.next(v2);
    END LOOP;
    DBMS_OUTPUT.PUT_LINE( 'Print all from last to first');
    v2 := v1.last;
    WHILE v2 IS NOT NULL
    LOOP
        DBMS_OUTPUT.PUT_LINE('Key= ' || v2 || ',Value=' || v1(v2));
        v2 := v1.prior(v2);
    END LOOP;
END;
/
first =
last =
prior =
next =
count = 0
first = a1
last = a9
count = 10
Print all from first to last
Key= a1,Value=a1
Key= a10,Value=a10
Key= a2,Value=a2
Key= a3,Value=a3
Key= a4,Value=a4
Key= a5,Value=a5
Key= a6,Value=a6
Key= a7,Value=a7
Key= a8,Value=a8
Key= a9,Value=a9
Print all from last to first
Key= a9,Value=a9
Key= a8,Value=a8
Key= a7,Value=a7
Key= a6,Value=a6
Key= a5,Value=a5
Key= a4,Value=a4
Key= a3,Value=a3
Key= a2,Value=a2
Key= a10,Value=a10
Key= a1,Value=a1
```

Anonymous PL block executed.

## Compatibility

The SQL standard does not define it.

## For More Information

Refer to [Collection Method Invocation](#).

## 28.8 CONTINUE Statement

### Function

It stops currently performing statement list, and performs the next iteration of a superordinate loop statement.

### Syntax

```
<continue statement> ::=  
    CONTINUE [ label_name ] [ WHEN condition ]  
    ;
```

### Invocation and Access Rules

It can be used only within PSM. (e.g. package, procedure, function)

It can be used only in the body section of a PL block.

A statement with a target label should be one of the following loop family statements.

- basic loop statement
- for loop statement
- while statement
- forall statement

### Syntax Rules and Parameters

- Label name
  - It can have an identifier chain form.
- Condition
  - If it is specified, it returns to a loop statement only when the condition is TRUE.

## Description

It stops currently performing statement list, and returns to the superordinate loop statement.

If a label is specified, it returns to the superordinate loop statement of the label name.

If a label is not specified, it returns to the nearest superordinate loop statement.

If multiple superordinate loop statements with the same names exist, then the nearest statement is selected.

It can return to a loop statement (exist in a nested scope) which is visible in the current location.

If a condition is specified, then it returns only when the condition is TRUE.

If a condition is not specified, then it definitely returns.

## Examples

```
DECLARE
  V1 INTEGER := 1;
BEGIN
  <<AAA>>
  WHILE V1 <= 10 LOOP
    DBMS_OUTPUT.PUT_LINE( 'V1 = ' || V1 );
    V1 := V1 + 1;
    IF V1 <= 2 THEN
      DBMS_OUTPUT.PUT_LINE( 'CONTINUE' );
      CONTINUE;
    ELSE
      EXIT;
    END IF;
    DBMS_OUTPUT.PUT_LINE( 'END-OF-WHILE' );
  END LOOP AAA;
END;
/
V1 = 1
CONTINUE
V1 = 2
Anonymous PL block executed.
```

## Compatibility

⟨continue statement⟩ statement is similar to ⟨iterate statement⟩ of the SQL standard. However, ⟨iterate statement⟩ statement does not provide WHEN condition feature.

## For More Information

Refer to the followings.

- [EXIT Statement](#)
- [GOTO Statement](#)

## 28.9 Cursor FOR LOOP Statement

### Function

It performs loops as many times as the number of rows in the result created by a query or a cursor declared by a user in PSM.

### Syntax

```

<Cursor For Loop statement> ::=
    FOR <Variable_Name> IN <Cursor>
    LOOP
        { <SQL procedure statement> ; }...
    END LOOP [ Label_Name ]
    ;
<Cursor> ::=
    < ( Implicit_Cursor_Query ) >
    | < Explicit_Cursor_Name > [ ( [ <actual param> ] ) ]

<Implicit_Cursor_Query> ::=
    SELECT statement
    | SELECT_FOR_UPDATE statement
    | INSERT_RETURNING_QUERY statement
    | UPDATE_RETURNING_QUERY statement
    | DELETE_RETURNING_QUERY statement
<actual param> ::=
    ( expression [ , expression ] .. )

```

### Invocation and Access Rules

It can be used only within PSM. (e.g. package, procedure, function)

It can be used only in the body of PSM.



## Syntax Rules and Parameters

The variable declared within For~Loop is valid only within that loop scope. (The variable can not be referenced from outside of that Cursor For Loop Block Scope)

### When Using Cursor Name

A cursor should already have been declared before performing LOOP by using a cursor name. For more information about an actual param, refer to **OPEN Statement**.

### When Using Cursor Query

It can perform only the query which can be internally processed by using an implicit cursor in GOLDILOCK S such as a select and a returning query.

## Description

It performs PSM statements within a loop by turning around loops as many time as the number of results created by a cursor.

If a cursor becomes invalid (e.g. closed) during LOOP, it does not perform the loop and it processes it as an error.

If an explicit cursor name is specified and the corresponding cursor is already opened, then it is processed as an error.

The variable to which a result of the cursor specified in FOR LOOP clause is returned is automatically created. (It is created as a row type of the result set to be returned by an execution result of a cursor.)

However, if an alias for a select target expression which is not a column of a specific table among results of a user cursor query is not specified, then an error may occur.

## Examples

### Using Explicit Cursor

```
DECLARE  
CURSOR c1 IS SELECT * FROM T1;  
BEGIN
```

```

FOR rec IN C1
LOOP
    DBMS_OUTPUT.PUT_LINE( 'RowCount=' || c1%rowcount || ',C1=' || rec.c1 || ', C2=' ||
rec.c2);
    END LOOP;
END;
/
RowCount=1,C1=1, C2=1
RowCount=2,C1=2, C2=2
RowCount=3,C1=3, C2=3
RowCount=4,C1=4, C2=4
RowCount=5,C1=5, C2=5
RowCount=6,C1=6, C2=6
RowCount=7,C1=7, C2=7
RowCount=8,C1=8, C2=8
RowCount=9,C1=9, C2=9
RowCount=10,C1=10, C2=10
Anonymous PL block executed.

```

## Using Cursor Query

```

BEGIN
    FOR rec IN (select * from t1)
    LOOP
        DBMS_OUTPUT.PUT_LINE( 'RowCount=' || sql%rowcount || ',C1=' || rec.c1 || ', C2=' ||
rec.c2);
    END LOOP;
END;
/
C1=1, C2=1
C1=2, C2=2
C1=3, C2=3
C1=4, C2=4
C1=5, C2=5
C1=6, C2=6
C1=7, C2=7
C1=8, C2=8
C1=9, C2=9
C1=10, C2=10
Anonymous PL block executed.

```

## For More Information

Refer to the followings.

- [Explicit Cursor Declaration and Definition](#)
- [GOTO Statement](#)
- [EXIT Statement](#)

## 28.10 Cursor Variable Declaration

### Function

It declares a cursor variable in DECLARE section of PSM.

### Syntax

```
<cursor variable declaration> ::=  
    variable_name <type>  
    ;  
<cursor type definition> ::=  
    TYPE <type_name> IS REF CURSOR [ RETURN <return type> ]  
<return type> ::=  
    <table_name | view_name | cursor_name | cursor_variable > % ROWTYPE  
    | <record_variable_name> % TYPE  
    | <record_type_name>
```

### Invocation and Access Rules

It can be used only within PSM. (e.g. package, procedure, function)

It can be used only in the declaration section of PSM.

### Syntax Rules and Parameters

Specifying the initial value of a cursor variable or assigning a cursor variable is allowed only between cursors or variables.

### Description

A cursor variable is operated like as a pointer indicating a cursor which is not dependent on a specific cursor.

## Examples

```
DECLARE
TYPE rec IS RECORD (V1 VARCHAR(20), V2 VARCHAR(20));
TYPE cv IS REF CURSOR RETURN rec;
BEGIN
    NULL;
END;
/
Anonymous PL block executed.
```

## For More Information

Refer to the followings.

- **OPEN Statement**
- **FETCH Statement**
- **CLOSE Statement**

## 28.11 DELETE Statement Extension

### Function

It can store the result in RETURNING INTO clause by using a record type variable of PSM.

### Syntax

```

<PSM delete statement extension: searched> ::=
    DELETE [ FROM ] table_name [ [ AS ] alias_name ]
        [ WHERE <search condition> ]
        [ <result offset clause> ]
        [ <fetch limit clause> ]
        [ <returning into clause> ]
    ;
<delete statement: positioned> ::=
    DELETE [ FROM ] table_name [ [ AS ] alias_name ]
        WHERE CURRENT OF cursor_name
    ;
<result offset clause> ::=
    OFFSET skip_count [ ROW | ROWS ]
<fetch limit clause> ::=
    <fetch first clause>
    | <limit clause>
<fetch first clause> ::=
    FETCH [ FIRST | NEXT ] [ row_count ] [ ROW ONLY | ROWS ONLY ]
<limit clause>
    LIMIT { fetch_row_count | offset_row_count, fetch_row_count | ALL }
<returning into clause> ::=
    { RETURN | RETURNING } { * | { <value expression> [ [AS] alias_name ] } [, ...] } INTO
    variable_name [, ...]

```

## Invocation and Access Rules

It can be used only within PSM. (e.g. package, procedure, function)

It can be used only in the body section of PSM.

## Syntax Rules and Parameters

If a variable to be returned through RETURNING INTO is a record type, then it can not be used by mixing together with a different variable type.

## Description

It can store the result in RETURNING INTO clause by using a record type variable of PSM.

## Examples

```
gSQL> CREATE TABLE T1( C1 VARCHAR(20), C2 VARCHAR(20));
Table created.
gSQL> COMMIT;
Commit complete.
gSQL> INSERT INTO T1 VALUES ('AAA', 'BBB'), ('BBB', 'CCC'), ('CCC', 'DDD');
3 rows created.
gSQL> COMMIT;
Commit complete.
gSQL> DECLARE
    rec t1%ROWTYPE;
BEGIN
    DELETE FROM T1 WHERE C1 = 'AAA' RETURNING * INTO rec;
    DBMS_OUTPUT.PUT_LINE('SQL%ROWCOUNT=' || SQL%ROWCOUNT);
    DBMS_OUTPUT.PUT_LINE('rec.c1=' || rec.c1 || ', rec.c2=' || rec.c2);
END;
/
SQL%ROWCOUNT=1
rec.c1=AAA, rec.c2=BBB
Anonymous PL block executed.
```

## For More Information

Refer to [Deleting Data](#).



## 28.12 EXCEPTION\_INIT Pragma

### Function

It sets the error code which is to be processed by a user-defined exception.

### Syntax

```
< PRAGMA EXCEPTION_INIT > ::=  
    PRAGMA EXCEPTION_INIT ( <Exception-Name>, <Internal-ErrorCode> )  
    ;
```

### Invocation and Access Rules

It can be used only within PSM. (e.g. package, procedure, function)

It can be used only in the declaration section of PSM.

### Syntax Rules and Parameters

A predefined exception can not be used in an exception name which is used as an argument. (A predefined exception name can not be declared.)

An exception name which is used as an argument in the same PL block DECLARE clause should be declared in advance. (Declaration of an exception name in different BLOCK can not be referenced.)

<Internal-ErrorCode> should be an internal error code existing within DB SYSTEM. (SUCCESS code can not be set.)

### Description

A user explicitly declares an exception name corresponding to an error code of DB SYSTEM.

## Examples

```
gSQL> DECLARE
user_exception_1 EXCEPTION;
PRAGMA EXCEPTION_INIT( user_exception_1, -17001);
BEGIN
  RAISE USER_EXCEPTION_1;
  EXCEPTION WHEN user_exception_1 THEN DBMS_OUTPUT.PUT_LINE('User Exception_1');
END;
/
User Exception_1
Anonymous PL block executed.
```

## Compatibility

Error codes are different each other according to a vendor, so it is not compatible each other.

## For More Information

Refer to the followings.

- [Exception Declaration](#)
- [Exception Handler](#)

## 28.13 Exception Declaration

### Function

It declares an exception name within a PL block.

### Syntax

```
< Exception-Declaration Statement > ::=  
    <Exception-Name> EXCEPTION  
    ;
```

### Invocation and Access Rules

It can be used only within PSM. (e.g. package, procedure, function)

It can be used only in the declaration section of PSM.

### Syntax Rules and Parameters

It can not declare a predefined exception name.

Duplicated declarations are not allowed in DECLARE clause of the same SCOPE.

### Description

A user explicitly declares an exception.

### Examples

```
DECLARE  
user_exception_1 EXCEPTION;
```

```
user_exception_2 EXCEPTION;
user_exception_3 EXCEPTION;
BEGIN
  RAISE USER_EXCEPTION_2;
  EXCEPTION WHEN user_exception_1 THEN DBMS_OUTPUT.PUT_LINE('User Exception_1');
           WHEN user_exception_2 THEN DBMS_OUTPUT.PUT_LINE('User Exception_2');
           WHEN user_exception_3 THEN DBMS_OUTPUT.PUT_LINE('User Exception_3');
END;
/
User Exception_2
Anonymous PL block executed.
```

## Compatibility

An exception declaration of the standard SQL is as follows, but GOLDILOCKS supports the syntax as above.

```
<condition declaration> ::=
DECLARE <condition name> CONDITION [ FOR <sqlstate value> ]
```

## For More Information

Refer to the followings.

- **Exception Declaration**
- **EXCEPTION\_INIT Pragma**

## 28.14 Exception Handler

### Function

It performs an operation defined for an exception which is explicitly occurred by a user or an operation defined for an implicit error due to a DB SYSTEM error occurred during performing PL/ SQL.

### Syntax

```
< Exception Handler Statement > ::=
    EXCEPTION < Exception_When_List >
    ;
< Exception_When_List > ::=
    WHEN < Exception_Name_List > THEN <executable statement list> [ WHEN OTHERS THEN
<executable statement list> ]
< Exception_Name_List > ::=
    <Exception_Name> [ { OR <Exception_Name> }... ]
```

### Invocation and Access Rules

It can be used within a PL block.

### Syntax Rules and Parameters

OTHERS (predefined exception) can not be specified together with another exception name by using OR. Duplicated specifying of OTHERS (predefined exception) is not allowed in an exception handler, and OTHERS should be specified at the last.

## Description

### Exception Types

Type	Definer	Has error	Has name	Raise implicitly	Raise explicitly
Predefined	System	Yes	Yes	Yes	Optionally
User-defined	User	If user assign	If user assign	No	Yes

A predefined exception has an exception name and an error code which are specified in advance in GOL DILOCKS.

Other exceptions are classified into an internally defined exception and a user-defined exception. An internally defined exception is that a user sets the internal error code name of GOLDILOCKS differently from a predefined exception name, and a user-defined exception is that only the exception name is declared without specifying a separate error code.

### Predefined Exception

**Table 28-6** Predefined exception type

Name	Description
CASE_NOT_FOUND	It can not satisfy all conditions of CASE WHEN, or ELSE clause is not defined.
DUP_VAL_ON_INDEX	INDEX duplicated error occurred.
INVALID_CURSOR	A cursor status is incorrect.
INVALID_NUMBER	It can not be converted to a number.
NO_DATA_FOUND	SELECT statement returns zero data.
ROWTYPE_MISMATCH	Field types of two RowType variables are different each other.
TOO_MANY_ROWS	It returns two or more rows.
VALUE_ERROR	It is an error such as type mismatch and invalid casting.
ZERO_DIVIDE	It tries dividing by 0.
OTHERS	It includes errors which are not defined in a predefined.

### Examples

```
gSQL> DECLARE
V1 INTEGER := 0;
BEGIN
  DBMS_OUTPUT.PUT_LINE('Step1');
  V1 := 1 / 0;
```

```
DBMS_OUTPUT.PUT_LINE('Step2');  
EXCEPTION WHEN OTHERS THEN DBMS_OUTPUT.PUT_LINE( 'Exception V1=' || V1);  
END;  
/  
Step1  
Exception V1=0  
Anonymous PL block executed.
```

## Compatibility

It does not support the SQL standard grammar.

## For More Information

Refer to the followings.

- [EXCEPTION\\_INIT Pragma](#)
- [Exception Declaration](#)

## 28.15 EXECUTE IMMEDIATE Statement

### Function

It executes a dynamic SQL within PSM.

### Syntax

```

<EXECUTE IMMEDIATE statement> ::=
    EXECUTE IMMEDIATE <dynamic-sql> [ <binding-parameters> ]
    ;
<dynamic-sql> ::=
    single_quote_string
    | psm_variable
<binding-parameters> ::=
    <into-clause>
    | <using-clause>
    | <returning-into-clause>
    | <into-clause> <using-clause>
    | <using-clause> <returning-into-clause>
<into-clause> ::=
    INTO psm_variable [ {, psm_variable} ... ]
<using-clause> ::=
    USING [ <Bind-Type> ] <expression> [ {, [ <Bind-Type> ] <expression>} ... ]
<Bind-Type> ::=
    IN
    | OUT
    | IN OUT
<returning-into-clause> ::=
    RETURNING INTO psm_variable [ {, psm_variable} ... ]

```

### Invocation and Access Rules

It can be used only within PSM. (e.g. package, procedure, function)

It can be used only in the body section of a PL block.



## Syntax Rules and Parameters

### Dynamic SQL

- `single_quote_string`: It is an SQL statement enclosed with a single quote ('). (`double_quote_string` is recognized as a variable in PSM.)
- `Psm-variable`: It is an SQL statement stored in a variable which is used in PSM.

The following is an example of expressing a data by using quote(s) in an SQL statement to be performed.

```
EXECUTE IMMEDIATE 'INSERT INTO t1 VALUES ( 'Tom' ) '; -- Tom
EXECUTE IMMEDIATE 'INSERT INTO t1 VALUES ( 'Tom''''House'' ) '; -- Tom'House
EXECUTE IMMEDIATE 'INSERT INTO t1 VALUES ( ''''''Tom'' ) '; -- 'Tom
EXECUTE IMMEDIATE 'INSERT INTO t1 VALUES ( CHR(39) || 'TOM' ) '; -- 'Tom
```

A marker (? or :V1) is used in a location where a user input a variable in a dynamic SQL. An SQL statement specified in a dynamic SQL should be valid.

### INTO Clause

The result of performing a dynamic SQL exists, and it is not bound through a marker, but the result of processing an SQL statement is returned. (It is internally a form of an implicit cursor fetch.)

The syntax is as follows.

```
EXECUTE IMMEDIATE 'SELECT ... FROM .. WHERE ...';
EXECUTE IMMEDIATE 'INSERT ... RETURNING ...';
EXECUTE IMMEDIATE 'UPDATE ... RETURNING ...';
EXECUTE IMMEDIATE 'DELETE ... RETURNING ...';
```

### USING Clause

It lists a variable or an expression in USING clause (IN can be omitted.) as many as the number of input variables used in a dynamic SQL.

If the result of performing a dynamic SQL exists, then it lists variables as many as the number of result columns in USING OUT clause. (when returning the results to INTO clause)

The result can be returned in the following syntax by using USING OUT.

```
EXECUTE IMMEDIATE 'SELECT x, y, z INTO :v1, :v2, :v3 ...';
EXECUTE IMMEDIATE 'INSERT INTO ... RETURNING C1, C2 INTO :V1, :V2';
EXECUTE IMMEDIATE 'UPDATE T1 SET .. RETURNING C1, C2 INTO :V1, :V2';
```

```
EXECUTE IMMEDIATE 'DELETE FROM ... RETURNING C1, C2 INTO :V1, :V2';
```

## RETURNING Clause

If INSERT/UPDATE/DELETE RETURNING INTO statement is used as a dynamic SQL, the result is returned by binding a variable specified in USING clause in OUT-mode in GOLDILOCKS.

The same result can be returned by using RETURNING-INTO clause for the compatibility with other DBMS.

## Other Rules

- DDL/ DCL can not use any BIND clause. (INTO, USING, RETURNING clause)
- It is used as OUT in INTO clause and RETURNING INTO clause, so a separate bind type can not be specified nor it be simultaneously used together.
- IN BIND type can use only a scalar type variable.
- OUT BIND type can use a record type variable, but a scalar type or a record type can not be listed being mixed together.
- A result can not be returned being divided through INTO clause and USING OUT or RETURNING INTO.

## Description

- If a dynamic SQL returns the result as a variable specified in INTO clause
  - A query returning two or more results causes TOO\_MANY\_ROWS exception.
  - If the result is zero, it causes NO\_DATA\_FOUND exception.
- If a dynamic SQL returns the result as a variable specified in USING or RETURNING clause
  - If two or more variables which are not ARRAY are returned, it causes TOO\_MANY\_ROWS exception.
  - If the result is zero, an error does not occur.
- The followings are results of which DDL/ DCL performs implicit cursor SQL%Attribute variables.
  - SQL%ROWCOUNT = 0
  - SQL%ISOPEN = FALSE
  - SQL%FOUND = FALSE
  - SQL%NOTFOUND = TRUE
- Other dynamic SQLs store SQL%Attribute values corresponding to the processing results of that SQL statement.

## Examples

```

gSQL> DECLARE
V1 INTEGER;
V2 VARCHAR(20);
BEGIN
    V1 := 1;
    V2 := 'abcdef';
    DBMS_OUTPUT.PUT_LINE('#INSERT');
    EXECUTE IMMEDIATE 'insert into t1 values (:a1, :a2)' USING v1, v2;
    EXECUTE IMMEDIATE 'select c1, c2 from t1 where c1 = 1' INTO v1, v2;
    DBMS_OUTPUT.PUT_LINE('C1='|| v1 || ', C2=' || v2);
    V1 := 1;
    V2 := 'xyz';
    DBMS_OUTPUT.PUT_LINE('#UPDATE');
    EXECUTE IMMEDIATE 'update t1 set c2 = :a1 where c1 = :a2' USING V2, V1;
    V1 := 1;
    V2 := '';
    DBMS_OUTPUT.PUT_LINE('#SELECT');
    EXECUTE IMMEDIATE 'select c1, c2 from t1 where c1 = :a1' INTO v1, v2 USING v1;
    DBMS_OUTPUT.PUT_LINE('C1='|| v1 || ', C2=' || v2);
    V1 := 1;
    V2 := '';
    DBMS_OUTPUT.PUT_LINE('#DELETE');
    EXECUTE IMMEDIATE 'delete from t1 where c1 = :a1' USING v1;
END;
/
#INSERT
C1=1, C2=abcdef
#UPDATE
#SELECT
C1=1, C2=xyz
#DELETE
Anonymous PL block executed.

```

## 28.16 EXIT Statement

### Function

It exits a loop statement which has the given label among superordinate loop statements, then performs the next statement.

### Syntax

```
<exit statement> ::=  
    EXIT [ label_name ] [ WHEN condition ]  
    ;
```

### Invocation and Access Rules

It can be used only within PSM. (e.g. package, procedure, function)

It can be used only in the body section of a PL block.

### Syntax Rules and Parameters

- Label name
  - It is a label name of a loop statement to be exited.
  - It can be in an identifier chain form.
- Condition
  - If a condition is specified, then it can exit a loop statement only when that condition is TRUE.

### Description

- It stops currently performing statement list and exits a superordinate loop statement.
- A statement with a target label should be one of the following loop family statements.
  - basic loop statement
  - for loop statement

- while statement
- forall statement
- If a label is specified, then it exits a superordinate loop statement which has that label name.
- If a label is not specified, then it exits the nearest superordinate loop statement.
- If multiple superordinate loop statements with the same label names exist, then the nearest statement is selected.
- It can exit only a loop statement (exist in a nested scope) which is visible in the current location.
- If a condition is specified, then it exits only when the condition is TRUE.
- If a condition is not specified, then it definitely exits.

## Examples

```

gSQL> DECLARE
  V1 INTEGER := 1;
BEGIN
  <<AAA>>
  WHILE V1 <= 10 LOOP
    DBMS_OUTPUT.PUT_LINE( 'V1 = ' || V1 );
    EXIT;
    V1 := V1 + 1;
  END LOOP AAA;
END;
/
V1 = 1
Anonymous PL block executed.

```

## Compatibility

It does not exist in the SQL standard.

## 28.17 Explicit Cursor Attribute

### Function

It returns the status value of a cursor defined in PSM.

### Syntax

```
<Explicit cursor attribute> ::=
  cursor_name '%' { ISOPEN | FOUND | NOTFOUND | ROWCOUNT }
```

### Invocation and Access Rules

It can be used only in the body section of PSM.

### Syntax Rules and Parameters

- Cursor\_name
  - It is the name of a cursor whose status value is to be obtained.

### Description

- It returns the status value of a given cursor.
  - ISOPEN: It is whether the current cursor is OPEN.
  - FOUND: It is whether the data is returned by the recent fetch.
  - NOTFOUND: It is an opposite of FOUND.
  - ROWCOUNT: It is the number of fetched records after the cursor is recently OPEN.
- The following values are returned according to the cursor status.

**Table 28-7** Results according to the performing moment

Attribute name	Before OPEN	After OPEN	After FETCH	After CLOSE
ISOPEN	FALSE	TRUE	TRUE	FALSE

Attribute name	Before OPEN	After OPEN	After FETCH	After CLOSE
FOUND	NULL	NULL	TRUE/FALSE	NULL
NOTFOUND	NULL	NULL	TRUE/FALSE	NULL
ROWCOUNT	NULL	NULL	N (the number)	NULL

## Examples

```

gSQL> CREATE TABLE T1 ( I1 INTEGER );
Table created.
gSQL> COMMIT;
Commit complete.
gSQL> DECLARE
    CURSOR C1 IS SELECT * FROM T1;
    V1 INTEGER := 0;
    V2 INTEGER := 0;
    TOTAL INTEGER := 0;
BEGIN
    FOR I IN 1..100 LOOP
        INSERT INTO T1 VALUES( I );
    END LOOP;
    COMMIT;
    IF NOT C1%ISOPEN THEN
        OPEN C1;
    END IF;
    LOOP
        FETCH C1 INTO V1;
        EXIT WHEN C1%NOTFOUND;
        TOTAL := TOTAL + V1;
        V2 := V1;
    END LOOP;
    DBMS_OUTPUT.PUT_LINE( 'COUNT = ' || C1%ROWCOUNT || ' TOTAL = ' || TOTAL );
    CLOSE C1;
END;
/
COUNT = 100 TOTAL = 5050
Anonymous PL block executed.

```

## Compatibility

It is not defined in the SQL standard.



## 28.18 Explicit Cursor Declaration and Definition

### Function

It declares a cursor in DECLARE section of PSM.

### Syntax

```

<cursor declaration> ::=
    CURSOR cursor_name [ <cursor param spec> ] RETURN rowtype
    ;
<cursor param spec> ::=
    ( <cursor param decl> [ , <cursor param decl> ] .. )
<cursor param decl> ::=
    param_name [ IN ] datatype [ { '=' | DEFAULT } expression ]
<cursor definition> ::=
    CURSOR cursor_name [ <cursor param spec> ] [ RETURN rowtype ]
    IS select_statement
    ;

```

### Invocation and Access Rules

It can be used only within PSM. (e.g. package, procedure, function)

It can be used only in the declaration section of a PL block.

### Syntax Rules and Parameters

#### Cursor Name

It is a cursor name to be declared.

The length of a cursor name should be shorter than 128 bytes.

It should be a unique name in that scope.

## RowType

It defines a record type of a cursor.

The number of select targets specified when defining a cursor should be same, and the data type should be compatible.

If a rowtype is not specified, then a rowtype which is appropriate to a SELECT target of select\_statement specified when defining a cursor is automatically specified.

## Param Name

It is a name which distinguishes parameters within a specific cursor.

It should be a unique name in that cursor.

If the name is as same as a name of another variable which can be referenced within a scope, then a parameter of that cursor is preferentially referenced.

## Data Type

It specifies the data type of the corresponding parameter.

It can use all built-in types provided by GOLDLOCKS and types defined within PSM.

However, a statement which restricts a scope (precision/ scale) can not be specified in a built-in type, but it is internally specified as the maximum scope of the corresponding data type.

## Select Statement

It specifies SELECT or SELECT ... FOR UPDATE statement which is to be performed by a cursor.

It can not use SELECT ... INTO statement.

## Description

- <explicit cursor declaration> statement declares or defines a cursor.
  - Cursor declaration: It declares only a name and format of a cursor.
  - Cursor definition: It detailedly defines a name, format of a cursor and SELECT statement to be performed.
- An explicit cursor is used by defining it after declaration. or it can be used by defining it without a declaration.
- When using an explicit cursor by defining it after declaration, then the cursor name, the parameter specification and the record type definition should exactly match.
- A declaration and a definition of an explicit cursor should exist in the same block.
- An explicit cursor is created when the cursor enters the defined block, and it is automatically CLOSED

and deleted when it exits the block.

- 'MAXIMUM\_NAMED\_CURSOR\_COUNT' property restricts the maximum number of explicit cursors which can be created in a specific time.
- The following variables can be used in SELECT statement performed by an explicit cursor.
  - Parameter of the cursor
  - All PSM variables which can be referenced in a scope at the time of declaration. (It is not a scope of the time of open.)
  - External bind parameter (in case of an anonymous PL block)
- An explicit cursor performing SELECT statement has the following properties.
  - INSENSITIVE (Changes by another transaction do not affect it.)
  - NON\_SCROLLABLE (It can not fetch the previous record again.)
  - READ\_ONLY (Only a read operation is available.)
  - WITH-HOLD (A cursor is not automatically closed even though COMMIT/ ROLLBACK is performed.)
- An explicit cursor performing SELECT ... FOR UPDATE statement has the following properties.
  - INSENSITIVE (Changes by another transaction do not affect it.)
  - NON\_SCROLLABLE (It can not fetch the previous record again.)
  - UPDATABLE (It can UPDATE/DELETE through a cursor location.)
  - WITHOUT-HOLD (A cursor is automatically closed when COMMIT/ ROLLBACK is performed.)

## Examples

```
gSQL> CREATE TABLE T1 ( I1 INTEGER, I2 VARCHAR(10) );
Table created.
gSQL> COMMIT;
Commit complete.
gSQL> INSERT INTO T1 VALUES( 1, 'AAA' );
1 row created.
gSQL> INSERT INTO T1 VALUES( 2, 'BBB' );
1 row created.
gSQL> INSERT INTO T1 VALUES( 3, 'CCC' );
1 row created.
gSQL> COMMIT;
Commit complete.
gSQL> DECLARE
    CURSOR C1( A1 INTEGER, A2 VARCHAR ) RETURN T1%ROWTYPE IS SELECT * FROM T1 WHERE I1 = A1 AND
I2 = A2;
    V1 T1%ROWTYPE;
BEGIN
    OPEN C1( 2, 'BBB' );
```

```
FETCH C1 INTO V1;  
DBMS_OUTPUT.PUT_LINE( 'V1.I1 = ' || V1.I1 || ' V1.I2 = ' || V1.I2 );  
CLOSE C1;  
END;  
/  
V1.I1 = 2 V1.I2 = BBB  
Anonymous PL block executed.
```

## Compatibility

It is not defined in the SQL standard.

## For More Information

Refer to the followings.

- **OPEN FOR Statement**
- **FETCH Statement**
- **CLOSE Statement**

## 28.19 FETCH Statement

### Function

It fetches a single record of OPEN cursor.

### Syntax

```
<fetch statement> ::=
    FETCH cursor_name <into clause>
    ;
<into clause> ::=
    INTO { variable [ , variable ] .. | record }
```

### Invocation and Access Rules

It can be used only within PSM. (e.g. package, procedure, function)

It can be used only in the body section of a PL block.

### Syntax Rules and Parameters

- Cursor name
  - It is a cursor name to be fetched.
- Variable
  - It is a scalar type variable or a bind parameter which stores a column value among the fetch results.
- Record
  - It is a record type variable to store the entire single record of which is the fetch result.

## Description

It fetches a record from an open cursor, then copies the value to a variable specified in INTO clause.

If a cursor is declared only but not defined, then an error occurs.

The cursor should be open.

A variable type given to INTO clause should be compatible with a data type of the fetched record result.

The number of variables given to INTO clause should be as same as the number of the cursor's SELECT targets.

However, if a variable given in INTO clause is a record type, then only a single variable should be specified.

Also, the number of the record variable fields should be as same as the number of SELECT targets.

If a fetch is called when a record to be fetched does not exist, then the value of target variables in INTO clause is not altered.

## Examples

```
gSQL> CREATE TABLE T1 ( I1 INTEGER );
Table created.
gSQL> COMMIT;
Commit complete.
gSQL> DECLARE
    CURSOR C1 IS SELECT * FROM T1;
    V1 INTEGER := 0;
    V2 INTEGER := 0;
    CNT INTEGER := 0;
    TOTAL INTEGER := 0;
BEGIN
    FOR I IN 1..100 LOOP
        INSERT INTO T1 VALUES( I );
    END LOOP;
    COMMIT;
    OPEN C1;
    LOOP
        FETCH C1 INTO V1;
        CNT := CNT + 1;
        TOTAL := TOTAL + V1;
        V2 := V1;
    EXIT WHEN V1 = 100;
```

```
END LOOP;  
CLOSE C1;  
DBMS_OUTPUT.PUT_LINE( 'CNT = ' || CNT || ' TOTAL = ' || TOTAL );  
END;  
/  
CNT = 100 TOTAL = 5050  
Anonymous PL block executed.
```

## Compatibility

It is not defined in the SQL standard.

## For More Information

Refer to the followings.

- [OPEN Statement](#)
- [CLOSE Statement](#)

## 28.20 FOR LOOP Statement

### Function

As long as an index variable has the given value scope, it performs internal statements by increasing or reversing the index variable by 1.

### Syntax

```
<for loop statement> ::=  
    FOR index_variable_name IN [ REVERSE ] lower_bound .. upper_bound  
    LOOP { <SQL procedure statement> ; }... END LOOP [ loop_name ]  
    ;
```

### Invocation and Access Rules

It can be used only within PSM. (e.g. package, procedure, function)

It can be used only in the body section of a PL block.

### Syntax Rules and Parameters

- Index variable name
  - It is a variable name to be used as an index in FOR statement. Internally, NATIVE\_BIGINT type variable is used.
- Lower bound
  - It should be an integer type. If a number with a floating point is used, then the number below decimal point is rounded up while converting the type.
- Upper bound
  - It should be an integer type. If a number with a floating point is used, then the number below decimal point is rounded up while converting the type.



## Description

*for loop* statement performs an internal statement list by increasing or decreasing the index variable value.

- If REVERSE is specified
  - an index variable is decreased by 1 from upper\_bound value, and it terminates execution of *for loop* statement when the index variable value becomes smaller than lower\_bound.
  - If upper\_bound value is smaller than lower\_bound then an internal statement list is not performed.
- If REVERSE is not specified
  - an index variable is increased by 1 from lower\_bound, and it terminates execution of *for loop* statement when the index variable value becomes bigger than upper\_bound.
  - If lower\_bound value is bigger than upper\_bound, then an internal statement list is not performed.

## Examples

```
gSQL> BEGIN
  FOR I IN 0 .. 5 LOOP
    DBMS_OUTPUT.PUT_LINE( 'I = ' || I );
  END LOOP;
END;
/
I = 0
I = 1
I = 2
I = 3
I = 4
I = 5
Anonymous PL block executed.
gSQL> BEGIN
  FOR I IN REVERSE 0 .. 5 LOOP
    DBMS_OUTPUT.PUT_LINE( 'I = ' || I );
  END LOOP;
END;
/
I = 5
I = 4
I = 3
```

```
I = 2
```

```
I = 1
```

```
I = 0
```

```
Anonymous PL block executed.
```

## Compatibility

It is not defined in the SQL standard.

## For More Information

Refer to the followings.

- **CONTINUE Statement**
- **EXIT Statement**
- **GOTO Statement**

## 28.21 Function Declaration and Definition

### Function

It declares and defines a nested function.

### Syntax

```

<nested function declaration> ::=
    FUNCTION func_name [ ( { param_name [IN|OUT|INOUT] datatype [ { := | DEFAULT } init_expr ]
} [, ...] ) ]
        RETURN datatype
    ;
<nested function definition> ::=
    FUNCTION func_name [ ( { param_name [IN|OUT|INOUT] datatype [ { := | DEFAULT } init_expr ]
} [, ...] ) ]
        RETURN datatype
        { IS | AS } <item_declaration> BEGIN <pl_stmt_list> END
    ;

```

### Invocation and Access Rules

It can be used only within PSM. (e.g. package, procedure, function)

It can be used only in the declaration section of a PL block.

### Syntax Rules and Parameters

#### func\_name

It is a name of function to be created, and it should be a unique name in a schema.

The length of a function name should be shorter than 128 bytes.

## Param Name

It defines a name of an argument to be used in a function.  
The name of each argument should be unique in a function.

## Bind Type

It specifies a bind type of each argument.  
If it is not specified, the default type is *IN*.

## Item Declaration

It declares items such as a local variable to be used within a function.  
It can declare all items which can be declared in a PL block.

## PL Stmt List

It is a body section of a function, and it lists PL statements to be performed.

## Description

A nested function is a sub program which can be called only within the corresponding procedure.  
Other usages are as same as those of a schema-level function.

## Examples

```
gSQL> DECLARE
  V1 INTEGER := 0;
  FUNCTION FUNC1( A1 INTEGER )
    RETURN INTEGER
  IS
  BEGIN
    RETURN A1 * 10;
  END;
BEGIN
  V1 := FUNC1( 10 );
  DBMS_OUTPUT.PUT_LINE( 'V1 = ' || V1 );
```

```
END;
```

```
/
```

```
V1 = 100
```

```
Anonymous PL block executed.
```

## Compatibility

It is as same as a schema-level function.

## For More Information

Refer to `CREATE FUNCTION`.

## 28.22 GOTO Statement

### Function

It tries to jump into the nearest statement which has a given label among statements accessible from the current location.

### Syntax

```
<goto statement> ::=  
    GOTO label_name  
    ;
```

### Invocation and Access Rules

It can be used only within PSM. (e.g. package, procedure, function)  
It can be used only in the body section of a PL block.

### Syntax Rules and Parameters

- Label\_name
  - It is a label name of a statement in which is to be jumped.
  - It can be in an identifier chain form.

### Description

It starts performing by jumping into a statement which has the corresponding label name.  
If multiple candidate statements exist, then it jumps into the nearest statement.  
It can jump only to a statement (exist in a nested scope) which is visible in the current location.  
Both forward jump and backward jump are possible.

## Examples

```
gSQL> DECLARE
  V1 INTEGER := 0;
BEGIN
  <<LABEL1>>
  IF V1 > 0 THEN
    GOTO LABEL2;
  END IF;
  V1 := V1 + 1;
  DBMS_OUTPUT.PUT_LINE('a');
  GOTO LABEL1;
  DBMS_OUTPUT.PUT_LINE('b');
  <<LABEL2>>
  DBMS_OUTPUT.PUT_LINE('c');
END;
/
a
c
Anonymous PL block executed.
```

## Compatibility

It is not defined in the SQL standard.

## For More Information

Refer to the followings.

- [EXIT Statement](#)
- [CONTINUE Statement](#)

## 28.23 IF Statement

### Function

It performs a statement list corresponding to the condition returning TRUE among the given conditions.

### Syntax

```
<if statement> ::=  
    IF <search condition> <if statement then clause>  
    [ <if statement elsif clause> ]  
    [ <if statement else clause> ]  
    END IF  
    ;  
<if statement then clause> ::=  
    THEN <executable statement list>  
<if statement elsif clause> ::=  
    ELSIF <search condition> THEN <executable statement list>  
<if statement elsif clause> ::=  
    ELSE <executable statement list>
```

### Invocation and Access Rules

It can be used only within PSM. (e.g. package, procedure, function)

It can be used only in the body section of a PL block.

### Syntax Rules and Parameters

- Search condition
  - It is an expression which can be finally evaluated as a boolean type.
- Executable statement list
  - It is a list of all statements supported by GOLDILOCKS PSM.



## Description

Like as CASE statement, it performs statement lists of IF, ELSIF clauses returning TRUE by evaluating conditions.

If it can not satisfy any condition and <if statement else clause> exists, then it performs the corresponding statement.

ELSIF clauses evaluates conditional expressions in order, and stops evaluating after finding the TRUE conditional clause.

## Examples

```
gSQL> DECLARE
  V1 INTEGER := 10;
BEGIN
  IF V1 > 0 THEN
    DBMS_OUTPUT.PUT_LINE( 'POSITIVE' );
  ELSIF V1 = 0 THEN
    DBMS_OUTPUT.PUT_LINE( 'ZERO' );
  ELSE
    DBMS_OUTPUT.PUT_LINE( 'NEGATIVE' );
  END IF;
END;
/
POSITIVE
Anonymous PL block executed.
```

## Compatibility

<if statement> statement is as same as a syntax and an operation of the SQL standard.

**Table 28-8** SQL standard compatibility

Feature ID	Description	Compatibility
P002	Computational completeness	O

## 28.24 Implicit Cursor Attribute

### Function

It returns the status value of an implicit cursor defined in PSM.

### Syntax

```
<Implicit cursor attribute> ::=  
    SQL '%' { ISOPEN | FOUND | NOTFOUND | ROWCOUNT }
```

### Invocation and Access Rules

It can be used only within PSM. (e.g. package, procedure, function)

It can be used only in the body section of a PL block.

### Description

- It stores the result of SQL statement which was executed just before.
  - ISOPEN: It is whether the cursor is OPEN, and it is always set to FALSE.
  - FOUND: It is whether the data is returned by the SQL result of just before.
  - NOTFOUND: It is an opposite of FOUND.
  - ROWCOUNT: It is the number of records affected by the SQL result of just before.

### Examples

```
DECLARE  
V1 INTEGER;  
BEGIN  
    SELECT COUNT(*) INTO V1 FROM T1;  
    DBMS_OUTPUT.PUT_LINE('COUNT RET    = ' || V1);  
    DBMS_OUTPUT.PUT_LINE('SQL%ISOPEN  = ' || SQL%ISOPEN);
```

```
DBMS_OUTPUT.PUT_LINE('SQL%FOUND = ' || SQL%FOUND);
DBMS_OUTPUT.PUT_LINE('SQL%NOTFOUND = ' || SQL%NOTFOUND);
DBMS_OUTPUT.PUT_LINE('SQL%ROWCOUNT = ' || SQL%ROWCOUNT);
END;
/
COUNT RET = 0
SQL%ISOPEN = FALSE
SQL%FOUND = TRUE
SQL%NOTFOUND = FALSE
SQL%ROWCOUNT = 1
Anonymous PL block executed.
```

## Compatibility

It is not defined in the SQL standard.

## 28.25 INSERT Statement Extension

### Function

It is an extended feature of an insert statement to input data by specifying record type variable supported in PSM in VALUES clause.

### Syntax

```

<PSM Insert Statement Extension Statement> ::=
    INSERT INTO table_name [ ( column_name [, ...] ) ]
        <Insert_source>
        [ <Returning_into_clause> ]
    ;
<Insert_source> ::=
    <value-list>
    | <from_subquery>
    | <from_default>
<from subquery> ::=
    <query_expression>
<from default> ::=
    DEFAULT VALUES
<Value-List> ::=
    VALUES <Value_item> [, ...]
    | VALUES psm_record_type_variable [, ...]
<value-Item> ::=
    ( { <value expression> | DEFAULT } [, ...] )
<Returning_into_clause> ::=
    [ RETURN | RETURNING ] { * | { <value_expression> [ [AS] alias_name ] } [, ...] INTO
variable_name [, ...]

```

### Invocation and Access Rules

It can be used only within PSM. (e.g. package, procedure, function)

It can be used only in the body section of a PL block.

A PSM insert extension statement can not be used in an original SQL statement of EXECUTE IMMEDIATE.

## Syntax Rules and Parameters

It is operated as same as the basic syntax of an insert statement. However, a feature specifying PSM record type variables are added other than a feature consecutively listing existing value expressions in parentheses in value item.

A PSM record type variable should be specified when using a variable without parentheses in Value\_Item. When using it in an insert extension statement form, a variable which is not a record type can not be used being mixed.

## Description

It stores a record by using a record type variable of PSM other than a general insert statement, or obtains a result through returning into.

For more information about insert, refer to the following example.

## Examples

```
gSQL> DECLARE
  rec t1%ROWTYPE;
BEGIN
  rec.i1 := 'AAA';
  rec.i2 := 'BBB';
  rec.i3 := 'CCC';
  INSERT INTO t1 (i1, i2, i3) VALUES rec ;
END;
/
Anonymous PL block executed.
gSQL> SELECT * FROM t1;
I1  I2  I3
---  ---  ---
AAA BBB CCC
```

## Compatibility

It is not defined in the SQL standard.

## 28.26 INSERT INTO ... UPDATE Statement Extension

### Function

It is the extended function of *insert into .. update* statement. It creates a new row in a table by specifying the record type variable supported by PSM in a values clause, or updates the row by specifying the variable in a set clause.

### Syntax

```

<PSM Upsert Statement Extension Statement > ::=
    INSERT INTO table_name [ ( column_name [, ...] ) ]
        <insert source>
        <duplicate key clause>
        [ <Returning_into_clause> ]
    ;
<insert source> ::=
    <values-list>
    | <from subquery>
    | <from_default>
<Value-List> ::=
    VALUES <Value_item> [, ...]
    | VALUES psm_record_type_variable [, ...]
<value-Item> ::=
    ( { <value expression> | DEFAULT } [, ...] )
<from subquery> ::=
    <query expression>
<from default> ::=
    DEFAULT VALUES
<duplicate key clause>
    ON DUPLICATE KEY { DO NOTHING | <do update clause> }
<do update clause> ::=
    [DO] UPDATE <target-list>
<target-List> ::=
    SET <set clause> [, ...]

```

```

    | SET ROW = <psm_variable>
<set clause> ::=
    column_name = { <value expression> | DEFAULT }
    | ( column_name [, ...] ) = ( { <value expression> | DEFAULT } [, ...] )
    | ( column_name [, ...] ) = ( <query expression> )
<returning_into_clause> ::=
    [ RETURN | RETURNING ] { * | { <value_expression> [ [AS] alias_name ] } [, ...] INTO
variable_name [, ...]

```

## Invocation and Access Rules

It can be used only within PSM. (e.g. procedure, function, package)

It can be used only in the body section of a PL block.

## Syntax Rules and Parameters

- <values clause>
  - The function specifying PSM record type variable other than consecutively listing existing value expressions in parentheses in the value item has been added.
  - PSM record type variable should be specified when using the variable without parentheses in the value item.
  - When describing by extending the value item, then the variable other than the record type variable is not allowed.
- <target list>
  - <PSM\_Variable> used in SET ROW statement should be the variable declared as the record type.
- <returning into clause>
  - <Variable> used in RETURNING INTO statement does not need to be a record type. However, if it is specified as a record type, then it can not be used together with other data type variables nor can a list two or more record type variables.

## Description

Returning into statement in an upsert statement stores the inserted result when insert is executed, and it stores the updated result when update is executed.



## Examples

- Execute insert.

```
gSQL> CREATE TABLE t1( c1 INTEGER UNIQUE, c2 INTEGER, c3 INTEGER );
Table created.
gSQL> DECLARE
  v_rec t1%ROWTYPE;
BEGIN
  v_rec.c1 := 1;
  v_rec.c2 := 1;
  v_rec.c3 := 1;

  INSERT INTO t1 VALUES v_rec ON DUPLICATE KEY UPDATE SET c1 = c1 + 1;
END;
/
Anonymous PL block executed.
gSQL> SELECT * FROM t1;
C1 C2 C3
-- -- --
 1  1  1
1 row selected.
```

- Execute update.

```
gSQL> CREATE TABLE t1( c1 INTEGER UNIQUE, c2 INTEGER, c3 INTEGER );
Table created.
gSQL> INSERT INTO t1 VALUES ( 1 , 1 , 1 );
1 row created.
gSQL> DECLARE
  v_rec t1%ROWTYPE;
BEGIN
  v_rec.c1 := 2;
  v_rec.c2 := 2;
  v_rec.c3 := 2;

  INSERT INTO t1 VALUES (1, 1, 1) ON DUPLICATE KEY UPDATE SET ROW = v_rec;
END;
/
gSQL> SELECT * FROM t1;
C1 C2 C3
```

```
-- -- --
 2  2  2
1 row selected.
```

- Returning statement of when executing insert

```
gSQL> CREATE TABLE t1( c1 INTEGER UNIQUE, c2 INTEGER, c3 INTEGER );
Table created.
gSQL> DECLARE
  v_rec1 t1%ROWTYPE;
  v_rec2 t1%ROWTYPE;
BEGIN
  v_rec1.c1 := 1;
  v_rec1.c2 := 1;
  v_rec1.c3 := 1;
  INSERT INTO t1 VALUES v_rec1 ON DUPLICATE KEY UPDATE SET c1 = c1 + 1 RETURNING * INTO
v_rec2;
  DBMS_OUTPUT.PUT_LINE( 'v_rec2.c1 : ' || v_rec2.c1 );
  DBMS_OUTPUT.PUT_LINE( 'v_rec2.c2 : ' || v_rec2.c2 );
  DBMS_OUTPUT.PUT_LINE( 'v_rec2.c3 : ' || v_rec2.c3 );
END;
/
v_rec2.c1 : 1
v_rec2.c2 : 1
v_rec2.c3 : 1
Anonymous PL block executed.
gSQL> SELECT * FROM t1;
C1 C2 C3
-- -- --
 1  1  1
1 row selected.
```

- Returning statement of when executing update

```
gSQL> CREATE TABLE t1( c1 INTEGER UNIQUE, c2 INTEGER, c3 INTEGER );
Table created.
gSQL> INSERT INTO t1 VALUES ( 1 , 1 , 1 );
1 row created.
gSQL> DECLARE
  v_rec1 t1%ROWTYPE;
  v_rec2 t1%ROWTYPE;
BEGIN
```

```
v_rec1.c1 := 2;
v_rec1.c2 := 2;
v_rec1.c3 := 2;
INSERT INTO t1 VALUES (1, 1, 1) ON DUPLICATE KEY UPDATE SET ROW = v_rec1 RETURNING * INTO
v_rec2;
DBMS_OUTPUT.PUT_LINE( 'v_rec2.c1 : ' || v_rec2.c1 );
DBMS_OUTPUT.PUT_LINE( 'v_rec2.c2 : ' || v_rec2.c2 );
DBMS_OUTPUT.PUT_LINE( 'v_rec2.c3 : ' || v_rec2.c3 );
END;
/
v_rec2.c1 : 2
v_rec2.c2 : 2
v_rec2.c3 : 2
Anonymous PL block executed.
gSQL> SELECT * FROM t1;
C1 C2 C3
-- -- --
 2  2  2
1 row selected.
```

## Compatibility

It is not defined in the SQL standard.

## 28.27 NULL Statement

### Function

It is a statement without any feature.

### Syntax

```
<null statement> ::=  
    NULL  
    ;
```

### Invocation and Access Rules

It can be used only within PSM. (e.g. package, procedure, function)

It can be used only in the body section of a PL block.

### Description

It is a statement without any feature, and used to set a label of a specific location.

### Examples

```
gSQL> BEGIN  
    FOR i in 1..10 LOOP  
        DBMS_OUTPUT.PUT_LINE( i );  
        IF i > 5 THEN  
            GOTO label1;  
        END IF;  
    END LOOP;  
<<label1>>  
    NULL;
```

```
END;  
/  
1  
2  
3  
4  
5  
6
```

Anonymous PL block executed.

## Compatibility

It is not defined in the SQL standard.

## 28.28 OPEN Statement

### Function

It executes SELECT statement of a cursor defined in PSM.

### Syntax

```
<open statement> ::=  
    OPEN cursor_name [ <actual param spec> ]  
    ;  
<actual param spec> ::=  
    ( expression [ , expression ] .. )
```

### Invocation and Access Rules

It can be used only within PSM. (e.g. package, procedure, function)

It can be used only in the body section of a PL block.

### Syntax Rules and Parameters

- Cursor\_name
  - It is the name of a cursor to be opened.

### Description

It executes SELECT or SELECT ... FOR UPDATE statement of a defined cursor.

If a cursor is declared only but is not defined, then an error occurs.

Values of actual parameters should be compatible with the data type of those parameters.

The number of actual parameters should be same as the number of parameters of a cursor.

If it is smaller than the number of parameters of a cursor, then the default value should be specified in all

other parameters.

## Examples

```
gSQL> CREATE TABLE T1 ( I1 INTEGER, I2 VARCHAR(10) );
Table created.
gSQL> COMMIT;
Commit complete.
gSQL> INSERT INTO T1 VALUES( 1, 'AAA' );
1 row created.
gSQL> INSERT INTO T1 VALUES( 2, 'BBB' );
1 row created.
gSQL> INSERT INTO T1 VALUES( 3, 'CCC' );
1 row created.
gSQL> COMMIT;
Commit complete.
gSQL> DECLARE
    CURSOR C1( A1 INTEGER := 1, A2 VARCHAR DEFAULT 'AAA') IS SELECT * FROM T1 WHERE I1 = A1 AND
I2 = A2;
    V1 INTEGER;
    V2 VARCHAR(10);
BEGIN
    OPEN C1( 1 );
    FETCH C1 INTO V1, V2;
    DBMS_OUTPUT.PUT_LINE( 'V1 = ' || V1 || ' V2 = ' || V2 );
    CLOSE C1;
END;
/
V1 = 1 V2 = AAA
Anonymous PL block executed.
```

## Compatibility

It is not defined in the SQL standard.

## For More Information

Refer to the followings.

- **CLOSE Statement**
- **FETCH Statement**



## 28.29 OPEN FOR Statement

### Function

It opens a single cursor by executing SELECT statement through a cursor variable defined in PSM.

### Syntax

```
<open statement> ::=  
    OPEN cursor_variable_name FOR <select_query>  
    ;
```

### Invocation and Access Rules

It can be used only within PSM. (e.g. package, procedure, function)

It can be used only in the body section of a PL block.

### Syntax Rules and Parameters

- Cursor\_Variable\_name
  - It is a name of cursor\_variable.
- Select\_query
  - A select query can use both a static SQL and a dynamic SQL.

### Description

It executes SELECT or SELECT ... FOR UPDATE statement of a defined cursor variable.

If a cursor previously opened by a cursor variable exists, then that cursor is automatically closed.

## Examples

```
gSQL> CREATE TABLE T1 (c1 INTEGER, c2 INTEGER, c3 INTEGER);
Table created.
gSQL> INSERT INTO T1 VALUES (1, 1, 1);
1 row created.
gSQL> INSERT INTO T1 VALUES (2, 2, 2);
1 row created.
gSQL> INSERT INTO T1 VALUES (3, 3, 3);
1 row created.
gSQL> INSERT INTO T1 VALUES (4, 4, 4);
gSQL> DECLARE
cv SYS_REFCURSOR;
rec t1%ROWTYPE;
BEGIN
  OPEN cv FOR SELECT * FROM T1;
  DBMS_OUTPUT.PUT_LINE('After Open> CV%ISOPEN=' || CV%ISOPEN);
  LOOP
    FETCH cv INTO rec;
    EXIT WHEN CV%NOTFOUND;
    DBMS_OUTPUT.PUT_LINE('C1=' || rec.c1 || ', C2=' || rec.c2 || ', c3=' || rec.c3 || ',
RowCount=' || cv%rowcount);
  END LOOP;
  CLOSE cv;
  DBMS_OUTPUT.PUT_LINE('After Close> CV%ISOPEN=' || CV%ISOPEN);
END;
/
After Open> CV%ISOPEN=TRUE
C1=1, C2=1, c3=1, RowCount=1
C1=2, C2=2, c3=2, RowCount=2
C1=3, C2=3, c3=3, RowCount=3
C1=4, C2=4, c3=4, RowCount=4
After Close> CV%ISOPEN=FALSE
Anonymous PL block executed.
```

## Compatibility

It is not defined in the SQL standard.

## For More Information

Refer to the followings.

- **Cursor Variable Declaration**
- **FETCH Statement**
- **CLOSE Statement**

## 28.30 Procedure Call

### Function

It calls a user-defined procedure, a built-in procedure or a nested procedure.

### Syntax

```
<Procedure call> ::=
    proc_name [ ( expr { , expr } ... ) ]
    ;
```

### Invocation and Access Rules

It can be used only within PSM. (e.g. package, procedure, function)

It can be used only in the body section of a PL block.

- The following privileges for the corresponding procedure are required to call the user-defined procedure.
  - EXECUTE PROCEDURE
  - (EXECUTE PROCEDURE or CONTROL SCHEMA) ON SCHEMA for the schema to which the procedure belongs
  - EXECUTE ANY PROCEDURE ON DATABASE

### Syntax Rules and Parameters

- Proc\_name
  - It is a name of a procedure to be executed, and it is used in the following format.

Format	Syntax	Description
Single identifier	procedure_name	It calls the procedure of the given name. It is searched in the following order. 1. nested procedure

Format	Syntax	Description
		2. schema-level procedure
identifier chain	label_name.procedure_name	It calls a nested procedure.
	schema_name.procedure_name	It calls a schema-level procedure.
	package_name.procedure_name	It calls a built-in procedure.

If the given the number and type of arguments which were given in the procedure found first are wrong when searching with the given name (proc\_name), then it does not search for another procedure but causes an error.

## Description

It calls a user-defined procedure, a built-in procedure or a nested procedure which was defined in advance.

The argument value in which the default value is defined can be omitted when calling.

When using a procedure variable or bind parameter (?, :V1) in an argument which were defines as OUT or IN-OUT, then the returned value is obtained.

## Examples

```
gSQL> DECLARE
  PROCEDURE PROC1( A1 INTEGER )
  IS
  BEGIN
    PUT_LINE( 'A1 = ' || A1 );
  END;
BEGIN
  PROC1( 100 );
END;
/
A1 = 100
Anonymous PL block executed.
```

## Compatibility

The SQL standard requires to use <call statement>.

## 28.31 Procedure Declaration and Definition

### Function

It declares and defines a nested procedure.

### Syntax

```

<nested procedure declaration> ::=
    PROCEDURE proc_name [ ( { param_name [IN|OUT|INOUT] datatype [ { := | DEFAULT }
init_expr ] } [, ...] ) ]
    ;
<nested procedure definition> ::=
    PROCEDURE proc_name [ ( { param_name [IN|OUT|INOUT] datatype [ { := | DEFAULT }
init_expr ] } [, ...] ) ]
    { IS | AS } <item_declaration> BEGIN <pl_stmt_list> END
    ;

```

### Invocation and Access Rules

It can be used in PSM declaration section.

### Syntax Rules and Parameters

- Proc\_name
  - It is a name of a procedure to be created, and it should be a unique name in a schema.
  - The length of a procedure name should be shorter than 128 bytes.
- Param\_name
  - It defines a name of an argument to be used by a procedure.
  - A name of each argument should be unique in a procedure.
- Bind\_type
  - It specifies a bind type of each argument.
  - If it is not specified, the default type is 'IN'.
- Item\_declaration

- It declares items such as a local variable to be used within a procedure.
- It can declare all items which can be declared in a PL block.
- PL Stmt list
  - It is a body section of a procedure, and it lists PL statements to be performed.

## Description

A nested procedure is a sub program which can be called only within the corresponding procedure. Other usages are as same as those of a schema-level procedure.

## Examples

```
gSQL> DECLARE
PROCEDURE PROC1( A1 INTEGER )
  IS
  BEGIN
    DBMS_OUTPUT.PUT_LINE( 'A1 = ' || A1 );
  END;
BEGIN
  PROC1( 100 );
END;
/
A1 = 100
Anonymous PL block executed.
```

## Compatibility

It is as same as a schema-level procedure.

## For More Information

Refer to [CREATE PROCEDURE](#).



## 28.32 RAISE Statement

### Function

It explicitly generates a user-defined exception.

### Syntax

```
<RAISE Statement> ::=  
    RAISE <Exception-Name>  
    ;
```

### Invocation and Access Rules

It can be used only within PSM. (e.g. package, procedure, function)

It can be used only in the body section of a PL block.

### Syntax Rules and Parameters

- A name of exception to be raised should be declared in a PL block to which a raise belongs or in DECLARE clause of a superordinate PL block. However, a predefined exception can be raised without a declaration.
- If a raise statement is used within an exception handler, an exception name can be omitted, in this case, the previous exception is spread to the superordinate block.

### Description

If it can not be processed in a PL block in which an exception occurred, then it is spread to the superordinate PL block.

If an exception to be raised does not exist in a PL block including RAISE statement, nor does exist in all exception handlers within a superordinate PL block, then an error occurs.

It is spread from a PL block in which RAISE exception occurred to a superordinate PL block until it is proce

ssed, and it can not be spread to an exception handler of subordinate PL block.

**Table 28-9** Propagating user exception

Raise exception	Exception handler SCOPE	Exception handler	Whether to spread it to superordinate
User exception without error code	Same scope	X	It spreads "unhandled exception" error to a superordinate scope.
User exception with error code	Superordinate scope	X	It spreads a user exception.
User exception with error code	Same scope	X	It spreads a user defined error code.
User exception with error code	Superordinate scope	X	It spreads a user defined error code.

## Examples

```

gSQL> DECLARE
V1 INTEGER;
exception1 EXCEPTION;
exception100 EXCEPTION;
BEGIN
    DBMS_OUTPUT.PUT_LINE('Step1');
    BEGIN
        RAISE exception1;
        DBMS_OUTPUT.PUT_LINE('Step2');
        EXCEPTION WHEN Exception100 THEN DBMS_OUTPUT.PUT_LINE('in Exception');
    END;
    DBMS_OUTPUT.PUT_LINE('Step3');
    EXCEPTION WHEN Exception1 THEN DBMS_OUTPUT.PUT_LINE('out Exception');
    DBMS_OUTPUT.PUT_LINE('Step4');
END;
/
Step1
out Exception
Step4
Anonymous PL block executed.

```

## Compatibility

The SQL standard specifies <handler declaration> and <condition declaration>, but it does not support the syntax.

## For More Information

Refer to the followings.

- [Exception Handler](#)
- [Exception Declaration](#)

## 28.33 Record Variable Declaration

### Function

It declares a record type variable in DECLARE section.

### Syntax

```
<declare record variable> ::=  
    variable_name <recordType>  
    ;  
<recordType> ::=  
    <tableName>%ROWTYPE  
    | USER_DEFINED_DATA_TYPE
```

### Invocation and Access Rules

It can be used only within PSM. (e.g. package, procedure, function)

It can be used only in the declaration section of a PL block.

### Syntax Rules and Parameters

- Variable\_name
  - It is a name of variable to be declared.
  - The length of the variable name should be shorter than 128 bytes.
  - It should be a unique name within a scope (PL block body).
  - A variable with the same name can be declared in a PL block body of nested subordinate.
  - It should be used in scope\_name.variable\_name form to correctly use the variables of duplicated declaration.
  - When using a variable of duplicated declaration without specifying the scope name, then a variable of the nearest scope is automatically used.
- Record\_type
  - It can use %ROWTYPE and user-defined recordType.
  - For more information about the declaration of recordType, refer to **User Defined Record Type**.

## Description

- The declared variable has the following features.
  - It should be a unique name within a scope (PL block body).
  - A variable with the same name can be declared in a PL block body of nested subordinate.
  - It should be used in `scope_name.variable_name` form to correctly use the variables of duplicated declaration.
  - When using a variable of duplicated declaration without specifying the scope name, then a variable of the nearest scope is automatically used.
- The declared variable is used in that scope and in its subordinate scope, but '::' is not added unlike an embedded SQL.
- The used variable is operated as a bind parameter (INOUT) for that SQL or a PSM control statement.

## Examples

```
gSQL> DECLARE
  TYPE MY_REC1 IS RECORD ( F1 INTEGER, F2 VARCHAR(10) );
  V1 MY_REC1;
BEGIN
  V1.F1 := 1;
  V1.F2 := 'AAA';
  INSERT INTO T1 VALUES( V1.F1, V1.F2 );
END;
/
Anonymous PL block executed.
gSQL> COMMIT;
Commit complete.
gSQL> SELECT * FROM T1;
I1 I2
-- ---
 1 AAA
1 row selected.
```

## Compatibility

It is not defined in the SQL standard.

## 28.34 RETURN Statement

### Function

It specifies the value of which a function returns, then terminates the function. A procedure does not specify the return value, but terminates the procedure.

### Syntax

```
<return statement> ::=  
    RETURN [ return_value_expr ]  
    ;
```

### Invocation and Access Rules

It can be used only within PSM. (e.g. package, procedure, function)  
It can be used only in the body section of a PL block.

### Syntax Rules and Parameters

- Return\_value\_expr
  - It is an expression of a value to be returned, and it can be specified only when it is a function.

### Description

It terminates a currently performing procedure/ function.

For a function, if RETURN statement is terminated without being performed, or if RETURN statement does not have return\_value\_expr, then an error occurs.

## Examples

```
gSQL> CREATE OR REPLACE FUNCTION FUNC1( A1 INTEGER, A2 INTEGER )
RETURN INTEGER
IS
  V1 INTEGER;
BEGIN
  SELECT COUNT(*)
  INTO V1
  FROM T1
  WHERE T1.I1 >= A1 AND T1.I1 <= A2;
RETURN V1;
END;
/
```

Function created.

## Compatibility

It is specified in the SQL standard, but conformance rules do not exist.

## 28.35 RETURNING INTO clause

### Function

The data processed in an insert/ update/ delete is returned to a PSM variable.

### Syntax

```

<Insert, Delete Returning_into_clause> ::=
    [ RETURN | RETURNING ] { * | { <value_expression> [ [AS] alias_name ] } [, ...] INTO
variable_name [, ...]
<Update returning into clause> ::=
    { RETURN | RETURNING } [ NEW | OLD ] { * | { <value expression> [ [AS] alias_name ] } [,
... ] } INTO Variable [, ...]

```

### Invocation and Access Rules

It can be used only within PSM. (e.g. package, procedure, function)

It can be used only in the body section of a PL block.

### Syntax Rules and Parameters

A record type variable can not be used being mixed with other types.

### Description

It stores before/ after record of processing an insert/ update/ delete statement through returning into.



## Examples

```
gSQL> DECLARE
  rec t1%ROWTYPE;
BEGIN
  INSERT INTO t1 VALUES (1, 2, 3) RETURNING * INTO rec ;
  UPDATE T1 SET ROW = rec RETURNING * INTO rec;
  DELETE FROM T1 RETURNING * INTO rec;
END;
/
```

Anonymous PL block executed.

## Compatibility

It is not defined in the SQL standard.

## 28.36 %ROWTYPE Attribute

### Function

When declaring a variable, it defines the structure and type as same as those of a specific table, a specific cursor or a result set of a cursor variable.

### Syntax

```
<rowtype attribute> ::=  
    <identifier chain> % ROWTYPE
```

### Invocation and Access Rules

- It can be used only within PSM. (e.g. package, procedure, function)
- It can be used only in the declaration section of a PL block.
- When declaring a variable, it can be used only in <data type> section.
- When declaring a record type field, then it can not be used in <data type> section. (It does not support complex data type.)

### Syntax Rules and Parameters

- Identifier chains are as follows.
  - The name of table, view, synonym to be referenced, or the name of a cursor or a cursor variable

### Description

- Search order of the reference targets
  - Cursor or cursor variable
  - Base table, view, or synonym
- Reference scope

- When referring by using a row attribute, only name and type of columns in a result set of a table or a cursor is referenced.
- Therefore, it does not refer to NOT NULL constraint or DEFAULT value settings.

## Examples

```
gSQL> CREATE TABLE T1 ( I1 INTEGER NOT NULL, I2 VARCHAR(10) );
Table created.
gSQL> INSERT INTO T1 VALUES( 123, '1234567890' );
1 row created.
gSQL> COMMIT;
Commit complete.
gSQL> DECLARE
    V1 T1%ROWTYPE;
BEGIN
    SELECT * INTO V1.I1, V1.I2 FROM T1;
    DBMS_OUTPUT.PUT_LINE( 'V1.I1 = ' || V1.I1 || ' V1.I2 = ' || V1.I2 );
END;
/
V1.I1 = 123 V1.I2 = 1234567890
Anonymous PL block executed.
```

## Compatibility

It is not defined in the SQL standard.

## 28.37 Scalar Variable Declaration

### Function

It declares a scalar variable in the declaration section.

### Syntax

```
<declare scalar variable> ::=  
    variable_name <data type> [ <variable initialize clause> ]  
    ;  
<variable initialize clause> ::=  
    [ NOT NULL ] { DEFAULT | := } <value expression>
```

### Invocation and Access Rules

It can be used only within PSM. (e.g. package, procedure, function)

It can be used only in the declaration section of a PL block.

### Syntax Rules and Parameters

- Variable\_name
  - It is a name of variable to be declared.
  - The length of the variable name should be shorter than 128 bytes.
  - It should be a unique name within a scope (PL block body).
  - A variable with the same name can be declared in a PL block body of nested subordinate.
  - It should be used in scope\_name.variable\_name form to correctly use the variables of duplicated declaration.
  - When using a variable of duplicated declaration without specifying the scope name, then a variable of the nearest scope is automatically used.
- Data\_Type
  - It can use all built-in **Data Type** provided in GOLDBLOCKS.
- Value\_expression
  - It expresses the initial value to specify in the variable.

- It can use all constants and expressions supported by GOLDBLOCKS except for multi-row functions.

## Description

- The declared variable has the following features.
  - It should be a unique name within a scope (PL block body).
  - A variable with the same name can be declared in a PL block body of nested subordinate.
  - It should be used in `scope_name.variable_name` form to correctly use the variables of duplicated declaration.
  - When using a variable of duplicated declaration without specifying the scope name, then a variable of the nearest scope is automatically used.
- The declared variable is used in that scope and in its subordinate scope, but '::' is not added unlike an embedded SQL.
- The used variable is operated as a bind parameter (INOUT) for that SQL or a PSM control statement.

## Examples

```

gSQL> CREATE TABLE T1 ( I1 INTEGER, I2 VARCHAR(10) );
Table created.
gSQL> COMMIT;
Commit complete.
gSQL> DECLARE
V1 INTEGER := 100;
V2 INTEGER := -100;
V3 VARCHAR(10) := 'ABC';
BEGIN
  IF V1 > 50 THEN
    INSERT INTO T1 VALUES ( V1, V3 );
  ELSE
    INSERT INTO T1 VALUES ( V2, V3 );
  END IF;
END;
/
Anonymous PL block executed.
gSQL> SELECT * FROM T1;
 I1 I2
--- ---

```

100 ABC

1 row selected.

## Compatibility

- The differences between <declare scalar variable> statement of GOLDILOCKS and that of SQL standard are as follows.
  - <SQL variable declaration> of the SQL standard declares a variable in a PL block body (after BEGIN), but GOLDILOCKS declares a variable in a separate declaration section.
  - The SQL standard can declare multiple variables of the same type by using a single DECLARE statement, but GOLDILOCKS can declare only a single variable by using a single statement.
  - The SQL standard uses only DEFAULT syntax when setting the initial value, but GOLDILOCKS can use an assign sign (:=).

## 28.38 SELECT INTO Statement

### Function

A single row is returned through SELECT.

### Syntax

```
<select statement: single row> ::=  
    SELECT [ <hint clause> ] [ <set quantifier> ] <select list>  
        INTO <select target list>  
        <table expression>  
    ;  
<select target list> ::=  
    variable_name [, ...]
```

### Invocation and Access Rules

It can be used only within PSM. (e.g. package, procedure, function)

It can be used only in the body section of a PL block.

### Syntax Rules and Parameters

The rules are as same as those of a select statement except the rules for INTO clause.

### Description

- SELECT INTO is used to return a single record.
  - If the number of results is zero, "NO\_DATA\_FOUND" exception occurs.
  - If the number of results are two or more, "TOO\_MANY\_ROWS" exception occurs.
- The result can be returned through a record type variable of PSM.
  - When using a record type variable, it can not be used being mixed with other type variables

## Examples

```
gSQL> CREATE TABLE T1 (c1 VARCHAR(20), c2 VARCHAR(20));
Table created.
gSQL> INSERT INTO T1 VALUES ('AAA', 'BBB'), ('BBB', 'CCC');
2 rows created.
gSQL> DECLARE
    v1 VARCHAR(20);
    v2 VARCHAR(20);
BEGIN
    SELECT * INTO v1, v2 FROM T1 WHERE c1 = 'AAA';
    DBMS_OUTPUT.PUT_LINE('V1=' || v1 || ', v2=' || v2);
END;
/
V1=AAA, v2=BBB
Anonymous PL block executed.
```

## Compatibility

It is not defined in the SQL standard.



## 28.39 SQLCODE Function

### Function

It returns an error code of a statement which was performed just before in PSM.

### Syntax

```
<SQLCODE function> ::= SQLCODE
```

### Invocation and Access Rules

It can be used only within PSM.

### Syntax Rules and Parameters

It does not have a separate argument.

### Description

It returns an error code of a statement performed in PL/SQL.

A user-defined exception which does not assign an error code returns to 1 at the time when it is processed by a handler.

When the error is completely processed by an exception handler, it returns to 0.

### Examples

```
gSQL> DECLARE  
V1 INTEGER;  
BEGIN
```

```
DBMS_OUTPUT.PUT_LINE('SQLCODE=[ ' || SQLCODE || ' ]');
DBMS_OUTPUT.PUT_LINE('SQLERRM=[ ' || SQLERRM || ' ]');
END;
/
SQLCODE=[0]
SQLERRM=[[SUNJESOFT][PL/SQL][GOLDILOCKS]successful completion]
Anonymous PL block executed.
```

## Compatibility

It is not defined in the SQL standard.

## 28.40 SQLERRM Function

### Function

It returns an error message of a statement which was performed just before in PSM.

### Syntax

```
<SQLERRM function> ::= SQLERRM
```

### Invocation and Access Rules

It can be used only within PSM.

### Syntax Rules and Parameters

It does not have a separate argument.

### Description

It returns an error message of a statement performed in PL/SQL.

A user-defined exception which does not assign an error code returns to a user-defined exception at the time when it is processed by a handler.

When the error is completely processed by an exception handler, it outputs successful completion message.

### Examples

```
gSQL> DECLARE  
V1 INTEGER;
```

```
BEGIN
  DBMS_OUTPUT.PUT_LINE('SQLCODE=[ ' || SQLCODE || ' ]');
  DBMS_OUTPUT.PUT_LINE('SQLERRM=[ ' || SQLERRM || ' ]');
END;
/
SQLCODE=[0]
SQLERRM=[[SUNJESOFT][PL/SQL][GOLDILOCKS]successful completion]
Anonymous PL block executed.
```

## Compatibility

It is not defined in the SQL standard.

## 28.41 %TYPE Attribute

### Function

When declaring a variable or defining a specific field of RECORD type, it defines the type as same as the column of a specific table or another variable.

### Syntax

```
<type attribute> ::=  
    <identifier chain> % TYPE
```

### Invocation and Access Rules

It can be used only within PSM. (e.g. package, procedure, function)

It can be used only in the declaration section of a PL block.

It can be used only for <data type> section when declaring a variable or a field of a record type.

### Syntax Rules and Parameters

- Identifier\_chain
  - It is the name of a table column to be referenced or of the existing declared variable (or a field of the variable).

### Description

#### Reference scope

The reference scope according to the referenced object types are as follows.

- When the referenced object is a column of a table
  - It refers to the data type of the column.

- It does not refer to a constraint (e.g. NOT NULL) of the column.
- It does not refer to the default initial value of the column.
- When the referenced object is another variable (or a field of a variable)
  - It refers to the data type of the variable (or a field).
  - It refers to a constraint (NOT NULL) of the variable (or a field).
  - It does not refer to the default initial value of the variable (or a field).
- Search order of the referenced target object is as follows.
  1. The name of a variable (or a field)
  2. The name of a column

## NOT NULL Constraints Variables References

It does not refer to the initial value when referring to NOT NULL attribute variable, so a new initial value should be specified.

Setting an initial value of a field is not supported when using a type attribute for the field of a current record type variable, so NOT NULL type field can not be referenced.

## Examples

```
gSQL> DECLARE
  V1 NUMBER(5,2) := 100.01;
  V2 V1%TYPE;
BEGIN
  DBMS_OUTPUT.PUT_LINE( 'V1 = ' || V1 );
  DBMS_OUTPUT.PUT_LINE( 'V2 = ' || V2 );
END;
/
V1 = 100.01
V2 =
Anonymous PL block executed.
```

## Compatibility

It is not defined in the SQL standard.

## 28.42 UPDATE Statement Extension

### Function

A feature altering a record by using a record type variable is added other than a feature consecutively listing the altering target columns of UPDATE statement in PSM.

It stores the result by using a record type variable in UPDATE (searched) RETURNING INTO clause in PSM.

### Syntax

```

<update Extension statement : searched> ::=
    UPDATE table_name [ [ AS ] alias_name ]
        <target-list>
        [ WHERE <search condition> ]
        [ <result offset clause> ]
        [ <fetch limit clause> ]
        [ <returning into clause> ]
    ;

<update statement: positioned> ::=
    UPDATE table_name [ [ AS ] alias_name ]
        <Target-List>
        WHERE CURRENT OF cursor_name
    ;

<result offset clause> ::=
    OFFSET skip_count [ ROW | ROWS ]

<fetch limit clause> ::=
    <fetch first clause>
    | <limit clause>

<fetch first clause> ::=
    FETCH [ FIRST | NEXT ] [ row_count ] [ ROW ONLY | ROWS ONLY ]

<limit clause>
    LIMIT { fetch_row_count | offset_row_count, fetch_row_count | ALL }

<returning into clause> ::=
    { RETURN | RETURNING } [ NEW | OLD ] { * | { <value expression> [ [AS] alias_name ] } [,
    ...] } INTO Variable [, ...]

<target-List> ::=
    SET <set clause> [, ...]
  
```

```

    | SET ROW = <psm_variable>
<set clause> ::=
    column_name = { <value expression> | DEFAULT }
    | ( column_name [, ...] ) = ( { <value expression> | DEFAULT } [, ...] )
    | ( column_name [, ...] ) = ( <query expression> )

```

## Invocation and Access Rules

It can be used only within PSM. (e.g. package, procedure, function)

It can be used only in the body section of a PL block.

## Syntax Rules and Parameters

- <PSM\_Variable> to be used in UPDATE SET ROW syntax should be a variable declared as a record type.
- <Variable> to be used in UPDATE RETURNING INTO syntax does not need to be a record type.
  - However, if a record type is specified, then it can not be used being mixed with other data type variables nor can two or more record type variables be listed.

## Description

It alters the record or stores the result of RETURNING INTO through a record type variable in PSM.

## Examples

```

gSQL> CREATE TABLE T1 (C1 VARCHAR(20), C2 VARCHAR(20));
Table created.
gSQL> INSERT INTO T1 VALUES ('AAA', 'BBB'), ('BBB', 'CCC'), ('CCC', 'DDD');
3 rows created.
gSQL> DECLARE
    v1 t1%ROWTYPE;
    v2 t1%ROWTYPE;
BEGIN
    v1.c1 := '1';
    v1.c2 := '2';

```



```
UPDATE T1 SET ROW = v1 WHERE c1 = 'AAA' RETURNING * INTO v2;
DBMS_OUTPUT.PUT_LINE('SQL%ROWCOUNT=' || SQL%ROWCOUNT );
DBMS_OUTPUT.PUT_LINE('v2.c1=' || v2.c1 || ', v2.c2=' || v2.c2);
END;
/
SQL%ROWCOUNT=1
v2.c1=1, v2.c2=2
Anonymous PL block executed.
gSQL> SELECT * FROM T1 ORDER BY C1;
C1  C2
--- ---
1   2
BBB CCC
CCC DDD
3 rows selected.
```

## Compatibility

It is not defined in the SQL standard.

## 28.43 WHILE LOOP Statement

### Function

It performs internal statements during <search condition> returns TRUE value.

### Syntax

```
<while loop statement> ::=  
    WHILE <search condition>  
    LOOP { <SQL procedure statement> ; }... END LOOP [ loop_name ]  
    ;
```

### Invocation and Access Rules

It can be used only within PSM. (e.g. package, procedure, function)

It can be used only in the body section of a PL block.

### Syntax Rules and Parameters

- Search conditions are as follows.
  - It is a conditional expression which continues to circle a while loop.
  - It should finally return a boolean type.

### Description

while loop statement performs an internal statement list as long as the evaluation result of <search condition> is TRUE.

## Examples

```
gSQL> DECLARE
V1 integer := 0;
BEGIN
  WHILE V1 < 10 LOOP
    DBMS_OUTPUT.PUT_LINE( 'V1 = ' || V1 );
    V1 := V1 + 1;
  END LOOP;
END;
/
V1 = 0
V1 = 1
V1 = 2
V1 = 3
V1 = 4
V1 = 5
V1 = 6
V1 = 7
V1 = 8
V1 = 9
```

Anonymous PL block executed.

## Compatibility

⟨while loop statement⟩ statement is defined as ⟨while statement⟩ in the SQL standard.

⟨while statement⟩ of the SQL standard performs loop statement as DO ... END WHILE, but GOLDILOCKS performs it as LOOP ... END LOOP.

## For More Information

Refer to the followings.

- [CONTINUE Statement](#)
- [EXIT Statement](#)
- [GOTO Statement](#)



**29.**

---

## **PSM SQL References**

## 29.1 ALTER FUNCTION

### Function

It recompiles a function.

### Syntax

```
<alter function statement> ::=  
    ALTER FUNCTION function_name COMPILE  
    ;
```

### Invocation and Access Rules

One of the following privilege is required to perform <alter function statement>.

- The owner of that function
- (ALTER PROCEDURE or CONTROL SCHEMA) ON SCHEMA for the schema to which the function belongs
- ALTER ANY PROCEDURE ON DATABASE

### Syntax Rules and Parameters

- function Name
  - It is the function name to be compiled.
  - It can define the schema to which the function belongs, such as schema\_name.func\_name. If schema\_name is omitted, the default schema name of the user performing the statement is used.

### Description

It recompiles a specified schema-level function.

## Examples

```
gSQL> ALTER FUNCTION FUNC1 COMPILE;  
Function altered.
```

## Compatibility

It is a statement altering characteristics specified when performing CREATE in the SQL standard, and a statement recreating a plan of a function in GOLDILOCKS.

**Table 29-1** SQL standard compatibility

Feature ID	Description	Compatibility
F381	Extended schema manipulation	O

## For More Information

Refer to the followings.

- CREATE FUNCTION
- DROP FUNCTION

## 29.2 ALTER PACKAGE

### Function

It recompiles a package.

### Syntax

```
<alter package statement> ::=  
    ALTER PACKAGE package_name <package compile clause>  
    ;  
<package compile clause> ::=  
    COMPILE [PACKAGE|SPECIFICATION|BODY]
```

### Invocation and Access Rules

One of the following privilege is required to perform <alter package statement>.

- The owner of that package
- (ALTER PACKAGE or CONTROL SCHEMA) ON SCHEMA for the schema to which the package belongs
- ALTER ANY PACKAGE ON DATABASE

### Syntax Rules and Parameters

- Package name
  - It is a name of package to be compiled.
  - It can define the schema to which the package belongs, such as schema\_name.package\_name. If schema\_name is omitted, the default schema name of the user performing the statement is used.
- Package compile clause
  - PACKAGE: It recompiles both the specification and the body. (Default)
  - SPECIFICATION: It recompiles only the specification.
  - BODY: It recompiles only the body.



## Description

It recompiles the specified package.

The execution code of the compiled package is stored in the plan cache.

## Examples

```
ALTER PACKAGE PKG1 COMPILE;  
Package altered.
```

```
ALTER PACKAGE PKG1 COMPILE PACKAGE;  
Package altered.
```

```
ALTER PACKAGE PKG1 COMPILE BODY;  
Package altered.
```

## Compatibility

It is ALTER MODULE statement in the SQL standard.

## For More Information

Refer to the followings.

- CREATE PACKAGE
- CREATE PACKAGE BODY
- DROP PACKAGE

## 29.3 ALTER PROCEDURE

### Function

It recompiles a procedure.

### Syntax

```
<alter procedure statement> ::=  
    ALTER PROCEDURE proc_name COMPILE  
    ;
```

### Invocation and Access Rules

One of the following privilege is required to perform <alter procedure statement>.

- The owner of that procedure
- (ALTER PROCEDURE or CONTROL SCHEMA) ON SCHEMA for the schema to which the procedure belongs
- ALTER ANY PROCEDURE ON DATABASE

### Syntax Rules and Parameters

- Proc Name
  - It is the procedure name to be compiled.
  - It can define the schema to which the procedure belongs, such as schema\_name.proc\_name. If schema\_name is omitted, the default schema name of the user performing the statement is used.

### Description

It recompiles a specified schema-level procedure.

## Examples

```

gSQL> CREATE OR REPLACE PROCEDURE PROC1( A1 INTEGER )
IS
BEGIN
  INSERT INTO T1 VALUES( A1 );
END;
/
ERR-01000(16409): Warning: Routine definition has compilation errors
ERR-HY000(17032): PSM compilation error :
(1) at (5:15): ERR-17053: schema or table object does not exist
Procedure created.
gSQL> CALL PROC1(1);
ERR-HY000(17032): PSM compilation error :
(1) at (5:15): ERR-17053: schema or table object does not exist
gSQL> CREATE TABLE T1( I1 INTEGER );
Table created.
gSQL> COMMIT;
Commit complete.
gSQL> ALTER PROCEDURE PROC1 COMPILE;
Procedure altered.
gSQL> COMMIT;
Commit complete.
gSQL> CALL PROC1(2);
Procedure Call complete.
gSQL> SELECT * FROM T1;
I1
--
 2
1 row selected.

```

## Compatibility

It is a statement altering characteristics specified when performing CREATE in the SQL standard, and a statement recreating a plan of a procedure in GOLDILOCKS.

**Table 29-2** SQL standard compatibility

Feature ID	Description	Compatibility
F381	Extended schema manipulation	O

## For More Information

Refer to the followings.

- **CREATE PROCEDURE**
- **DROP PROCEDURE**

## 29.4 CALL Statement

### Function

It performs a schema-level procedure or a function.

### Syntax

```

<call statement> ::=
    <sql call statement> | <odbc procedure call escape sequence>
    ;
<sql call statement> ::=
    CALL proc_name [ ( value_expr [ , value_expr ] .. ) ] [ INTO { '?' | { host_param [
indicator_param ] } } ]
<odbc procedure call escape sequence> ::=
    '{' [ ? = ] CALL proc_name [ ( value_expr [ , value_expr ] .. ) ] '}'

```

### Invocation and Access Rules

One of the following privilege is required to perform <call statement>.

- The EXECUTE privilege for that procedure
- (EXECUTE PROCEDURE or CONTROL SCHEMA) ON SCHEMA for the schema to which the procedure belongs
- EXECUTE ANY PROCEDURE ON DATABASE

### Syntax Rules and Parameters

- proc\_name
  - It is a name of a procedure/ function to be executed.
  - It may includes a schema to which the procedure belongs such as Schema\_name.Proc\_name.
- value\_expr
  - It expresses an argument value which were transferred to the procedure. It can use a bind parameter such as '?' or ':V1'.

## Description

It executes a schema-level SQL procedure or a function by using specified arguments.

A function of `<sql call statement>` form returns the result value by using a host variable expression or a dynamic bind parameter (?) after INTO clause.

`<odbc procedure call escape sequence>` form is a standard statement to call PROCEDURE in ODBC/JDBC, and GOLDILOCKS supports this statement in a server. (It can also be used in a tool such as gsql.) A function returns the result value by using assign expressions ( ? = ) at the front.

## Examples

### Call Procedure

```
gSQL> CREATE OR REPLACE PROCEDURE PROC1
(
  A1 INTEGER
)
IS
BEGIN
  DBMS_OUTPUT.PUT_LINE('A1= ' || A1);
END;
/
Procedure created.
gSQL> \var v1 INTEGER;
gSQL> \exec :v1 := 123;
gSQL> CALL PROC1(:v1);
A1=123
Procedure Call complete.
```

### Call Function

```
CREATE OR REPLACE FUNCTION FUNC1
(
  A1 INTEGER
)
RETURN INTEGER
```

```
IS
BEGIN
    return A1;
END;
/
Function created.
gSQL> \var v1 INTEGER;
gSQL> \var v2 INTEGER;
gSQL> \exec :v1 := 123;
gSQL> CALL FUNC1(:v1) INTO :v2;
Procedure Call complete.
gSQL> \print v2;
V2
---
123
```

## Compatibility

The SQL standard allows only the call for a PROCEDURE, so it does not define below [INTO] clause.

## 29.5 CREATE FUNCTION

### Function

It defines a schema-level function.

### Syntax

```

<create procedure statement> ::=
    CREATE [ OR REPLACE ]
        FUNCTION func_name [ ( { param_name [IN|OUT|INOUT] datatype [ { := | DEFAULT }
init_expr ] } [, ...] ) ]
        RETURN datatype
        [ <func_characteristics> ]
        { IS | AS } <item_declaration> BEGIN <pl_stmt_list> END
    ;
<func_characteristics> ::=
    DETERMINISTIC | AUTHID CURRENT_USER | AUTHID DEFINER

```

### Invocation and Access Rules

The user should satisfy the following conditions to perform <create function statement>.

- One of the following privileges is required to create a function.
  - (CREATE PROCEDURE or CONTROL SCHEMA) ON SCHEMA for the schema to which the function belongs
  - CREATE ANY PROCEDURE ON DATABASE
- If a function already exists when using OR REPLACE clause, then one of the following privileges dropping the existing function is required.
  - The owner of that function
  - (DROP PROCEDURE or CONTROL SCHEMA) ON SCHEMA for the schema to which the function belongs
  - DROP ANY PROCEDURE ON DATABASE
- The user who performed the statement becomes the owner of the created function.



# Syntax Rules and Parameters

## OR REPLACE

It replaces an existing function when the function already exists.

## FUNCTION NAME

It is a name of function to be created, and it should be a unique name in a schema.

It can define the schema to which the function belongs, such as `schema_name.func_name`. If `schema_name` is omitted, the default schema name of the user performing the statement is used.

The length of a function name should be shorter than 128 bytes.

## PARAM NAME

It defines a name of an argument to be used in a function.

The name of each argument should be unique in a function.

The length of each argument name should be shorter than 128 bytes.

It does not limit the maximum number of an argument to be used in a single function.

## Bind Type

It specifies a bind type of each argument.

If it is not specified, the default type is IN.

## Func\_Characteristics

It defines options to perform a function. It should be specified only once per a single item.

- DETERMINISTIC: The function always returns the same result value when the same argument values are input.
- AUTHID CURRENT\_USER: SQLs which are being performed during performing a function are interpreted and performed according to an authorization of an invoker.
- AUTHID DEFINER: SQLs which are being performed during performing a function are interpreted and performed according to an authorization of a definer.

## Item Declaration

It declares items such as a local variable to be used within a function.

It can declare all items which can be declared in a PL block.

## PL Stmt List

It is a body section of a function, and it lists PL statements to be performed.

It can not use a bind parameter such as '?' or ':V1'. within a function.

## Description

It defines a schema-level SQL function. The created function can be called from all expressions.

The definition of a function can be viewed in ROUTINES table of INFORMATION\_SCHEMA. The definition of a function parameter can be viewed in PARAMETERS table of INFORMATION\_SCHEMA.

If a function becomes temporarily unstable due to absences of related objects, then it can try to recreate a plan by using <alter function> statement.

The created function can be dropped by using <drop function> statement.

The maximum number of functions to be created is not limited. Therefore, they can be created as many as the storage space is available.

## Examples

```
gSQL> CREATE OR REPLACE FUNCTION FUNC1( A1 INTEGER, A2 INTEGER )
RETURN INTEGER
IS
  V1 INTEGER;
BEGIN
  SELECT COUNT(*)
  INTO V1
  FROM T1
  WHERE T1.I1 >= A1 AND T1.I1 <= A2;
  RETURN V1;
END;
/
```

Function created.

## Compatibility

The SQL standard does not define OR REPLACE clause.

**Table 29-3** SQL standard compatibility

Feature ID	Description	Compatibility
T471	Result sets return value	X
T341	Overloading of SQL-invoked functions and SQL-invoked procedures	X
S023	Basic structured types	X
S241	Transform functions	X
S024	Enhanced structured types	X
T571	Array-returning external SQL-invoked functions	X
T572	Multiset-returning external SQL-invoked functions	X
S201	SQL routines on arrays	X
S202	SQL-invoked routines on multisets	X
T323	Explicit security for external routines	X
S231	Structured type locators	X
S232	Array locators	X
S233	Multiset locators	X
T041	Basic LOB data type support	X
S027	Create method by specific method name	X
T041	Basic LOB data type support	X
T324	Explicit security for SQL routines	O
T326	Table functions	X
T651	SQL-schema statements in SQL routines	X
T652	SQL-dynamic statements in SQL routines	O
T653	SQL-schema statements in external routines	X
T654	SQL-dynamic statements in external routines	X
T655	Cyclically dependent routines	X
T272	Enhanced savepoint management	X
T522	Default values for IN parameters of SQL-invoked procedures	O
B121	Routine language Ada	X
B122	Routine language C	X
B123	Routine language COBOL	X
B124	Routine language Fortran	X
B125	Routine language MUMPS	X
B126	Routine language Pascal	X

Feature ID	Description	Compatibility
B127	Routine language PL/I	X
B128	Routine language SQL	O
B129	Routine language Ada: VARCHAR and NUMERIC support	X

## For More Information

Refer to the followings.

- **DROP FUNCTION**
- **ALTER FUNCTION**

## 29.6 CREATE PACKAGE

### Function

It defines the spec about public items to be used in a package.

### Syntax

```

<create package statement> ::=
    CREATE [ OR REPLACE ]
        PACKAGE package_name
        [ <package_characteristics> ]
        { IS | AS }
        <item_declaration>
    END
    ;
<package_characteristics> ::=
    AUTHID CURRENT_USER | AUTHID DEFINER
<item_declaration> ::=    <variable declaration>
                          | <cursor declaration>
                          | <user-defined type declaration>
                          | <function declaration>
                          | <procedure declaration>
                          | <user exception declaration>
                          | <cursor definition>

```

### Invocation and Access Rules

The user should satisfy the following conditions to perform <create package statement>.

- One of the following privileges is required to create a package.
  - (CREATE PACKAGE or CONTROL SCHEMA) ON SCHEMA for the schema to which the package belongs
  - CREATE ANY PACKAGE ON DATABASE
- If a package already exists when using OR REPLACE clause, then one of the following privileges dropping the existing package is required.

- The owner of that package
- (DROP PACKAGE or CONTROL SCHEMA) ON SCHEMA for the schema to which the package belongs
- The user who performed the statement becomes the owner of the created package.

## Syntax Rules and Parameters

### OR REPLACE

It replaces an existing package specification when the package already exists.

### PACKAGE NAME

It is a name of package to be created, and it should be a unique name in a schema.

It can define the schema to which the package belongs, such as `schema_name.package_name`. If `schema_name` is omitted, the default schema name of the user performing the statement is used.

The length of a package name should be shorter than 128 bytes.

## Package Characteristics

It defines options to perform a package. It should be specified only once per a single item.

- AUTHID CURRENT\_USER: SQLs which are being performed during performing items in a package are interpreted and performed according to an authorization of an invoker.
- AUTHID DEFINER: SQLs which are being performed during performing items in a package are interpreted and performed according to an authorization of a definer.

## Item Declaration

It declares a public variable, a type cursor, a cursor variable, a function spec, and a procedure spec which are accessible from out of the package.

A function and a procedure in the package should be defined through *create package body* statement.

The cursor which was declared in a package without SQL should be defined through *create package body* statement.

Also, a function, a procedure, an argument of a cursor and the returning type in a package should be as same as those defined in a body statement.

## Description

It creates the schema-level package specification.

All public items in the created package can be referred by another procedure/ function/ package/ anonymous block.

The information about package creation can be viewed in MODULES table in DEFINITION\_SCHEMA or INFORMATION\_SCHEMA.

The list of each public procedure/ function in the package can be viewed in ROUTINES table in DEFINITION\_SCHEMA or INFORMATION\_SCHEMA.

The definition about parameters of each public procedure/ function in the package can be viewed in PARAMETERS table in DEFINITION\_SCHEMA or INFORMATION\_SCHEMA.

Private procedure/ function can be viewed in MODULE\_BODY table.

If the information about objects referred by a procedure/ function/ variable in the package are temporarily unstable, try to recompile it by using <alter package> statement.

## Examples

```
CREATE OR REPLACE PACKAGE PKG1
IS
  V1 INTEGER;
  PROCEDURE PROC1;
  FUNCTION FUNC1 RETURN INTEGER;
END;
/
Package created.
```

## Compatibility

It is CREATE MODULE statement in the SQL standard.

## For More Information

Refer to the followings,

- CREATE PACKAGE BODY

- DROP PACKAGE
- ALTER PACKAGE



## 29.7 CREATE PACKAGE BODY

### Function

It creates the definition about procedure/ function/ cursors to be used in the package.

### Syntax

```

<create package body statement> ::=
    CREATE [ OR REPLACE ] PACKAGE BODY package_name
    { IS | AS }
    <item_declaration>
    <cursor_definition>
    <routine_definition>
    [ BEGIN <initialization part> ]
    END
    ;

<item_declaration> ::=    VARIABLE_DECLARATION
                          | CURSOR_DECLARATION
                          | USER_DEFINED_TYPE_DEFINITION
                          | FUNCTION_DECLARATION
                          | PROCEDURE_DECLARATION
                          | USER_EXCEPTION_DECLARATION

<routine_definition> ::= FUNCTION_DEFINITION
                          | PROCEDURE_DEFINITION

<initialization part> ::= <pl_stmt_list>

```

### Invocation and Access Rules

The user should satisfy the following conditions to perform <create package body statement>.

- One of the following privileges is required to create a package body.
  - (CREATE PACKAGE or CONTROL SCHEMA) ON SCHEMA for the schema to which the package belongs
  - CREATE ANY PACKAGE ON DATABASE
- The package spec should be defined in advance.

- If a package body already exists when using OR REPLACE clause, then one of the following privileges dropping the existing package is required.
  - The owner of that package
  - (DROP PACKAGE or CONTROL SCHEMA) ON SCHEMA for the schema to which the package belongs
  - DROP ANY PACKAGE ON DATABASE
- The user who performed the statement becomes the owner of the created package.

## Syntax Rules and Parameters

### OR REPLACE

It replaces an existing package body definition when the package body already exists.

### PACKAGE NAME

It is a name of package body to be created, and the name as same as the name used in creating a package spec should be used. It should be a unique name in a schema.

It can define the schema to which the package belongs, such as schema\_name.package\_name. If schema\_name is omitted, the default schema name of the user performing the statement is used.

The length of a package name should be shorter than 128 bytes.

### Item Declaration

It declares PSM identifiers (variable, type, cursor, function spec, procedure spec, exception) to be used in a package body.

Routines declared in a package spec should be defined in a package body.

The cursor which was declared in a package spec without SQL should be defined in a package body.

Also, a function, a procedure, an argument of a cursor and the returning type in a package should be as same as those defined in a body statement.

### Initialization Part

It describes statements which are performed only once to initialize internal variables while creating a package instance.

## Description

It creates the schema-level package specification.

All public items in the created package can be referred by another procedure/ function/ package/ anonymous block.

The information about package body creation can be viewed in MODULES\_BODY table in DEFINITION\_SCHEMA or INFORMATION\_SCHEMA.

The list of each private items in a package body can not be viewed in DEFINITION\_SCHEMA or INFORMATION\_SCHEMA.

If the information about objects referred by a procedure/ function/ variable in the package are temporarily unstable, try to recompile it by using <alter package body> statement.

The created package body can be dropped by using <drop package> or <drop package body> statement.

## Examples

```
CREATE OR REPLACE PACKAGE PKG1
IS
  V1 INTEGER;
  PROCEDURE PROC1;
  FUNCTION FUNC1 RETURN INTEGER;
END;
/
Package created.
CREATE OR REPLACE PACKAGE BODY PKG1
IS
  FUNCTION FUNC1 RETURN INTEGER
  IS
  BEGIN
    RETURN V1;
  END;
  PROCEDURE PROC1
  IS
  BEGIN
    IF V1 IS NULL
    THEN
      V1 := 10;
    ELSE
```

```
        V1 := V1 + 10;  
    END IF;  
END;  
/  
Package created.
```

## Compatibility

The SQL standard does not define it.

## For More Information

Refer to the followings.

- **CREATE PACKAGE**
- **DROP PACKAGE**
- **ALTER PACKAGE**

## 29.8 CREATE PROCEDURE

### Function

It defines a schema-level procedure.

### Syntax

```

<create procedure statement> ::=
    CREATE [ OR REPLACE ]
        PROCEDURE proc_name [ ( { param_name [IN|OUT|INOUT] datatype [ { := | DEFAULT }
init_expr ] } [, ...] ) ]
        [ <proc_characteristics> ]
        { IS | AS } <item_declaration> BEGIN <pl_stmt_list> END
    ;
<proc_characteristics> ::=
    AUTHID CURRENT_USER | AUTHID DEFINER

```

### Invocation and Access Rules

The user should satisfy the following conditions to perform <create procedure statement>.

- One of the following privileges is required to create a procedure.
  - (CREATE PROCEDURE or CONTROL SCHEMA) ON SCHEMA for the schema to which the procedure belongs
  - CREATE ANY PROCEDURE ON DATABASE
- If a procedure already exists when using OR REPLACE clause, then one of the following privileges dropping the existing procedure is required.
  - The owner of that procedure
  - (DROP PROCEDURE or CONTROL SCHEMA) ON SCHEMA for the schema to which the procedure belongs
  - DROP ANY PROCEDURE ON DATABASE
- The user who performed the statement becomes the owner of the created procedure.

## Syntax Rules and Parameters

### OR REPLACE

It replaces an existing procedure when the procedure already exists.

### PROC NAME

It is a name of procedure to be created, and it should be a unique name in a schema.

It can define the schema to which the procedure belongs, such as `schema_name.proc_name`. If `schema_name` is omitted, the default schema name of the user performing the statement is used.

The length of a procedure name should be shorter than 128 bytes.

### PARAM NAME

It defines a name of an argument to be used in a procedure.

The name of each argument should be unique in a procedure.

The length of each argument name should be shorter than 128 bytes.

It does not limit the maximum number of an argument to be used in a single procedure.

### Bind Type

It specifies a bind type of each argument.

If it is not specified, the default type is IN.

### proc\_characteristics

It defines options to perform a procedure. It should be specified only once per a single item.

- AUTHID CURRENT\_USER: SQLs which are being performed during performing a procedure are interpreted and performed according to an authorization of an invoker.
- AUTHID DEFINER: SQLs which are being performed during performing a procedure are interpreted and performed according to an authorization of a definer.

### Item Declaration

It declares items such as a local variable to be used within a procedure.

It can declare all items which can be declared in a PL block.

## PL Stmt List

It is a body section of a procedure, and it lists PL statements to be performed.

It can not use a bind parameter such as '?' or ':V1'. within a procedure.

## Description

It defines a schema-level SQL procedure. The created procedure can be called from CALL statement, anonymous block, or other procedure/ function.

The definition of a procedure can be viewed in ROUTINES table of INFORMATION\_SCHEMA. The definition of a procedure parameter can be viewed in PARAMETERS table of INFORMATION\_SCHEMA.

If a procedure becomes temporarily unstable due to absences of related objects, then it can try to recreate a plan by using <alter procedure> statement.

The created procedure can be dropped by using <drop procedure> statement.

The maximum number of procedures to be created is not limited. Therefore, they can be created as many as the storage space is available.

## Examples

```
gSQL> CREATE OR REPLACE PROCEDURE PROC1( A1 INTEGER, A2 INTEGER )
  IS
  V1 INTEGER;
BEGIN
  SELECT COUNT(*)
  INTO V1
  FROM T1
  WHERE T1.I1 >= A1 AND T1.I1 <= A2;
  DBMS_OUTPUT.PUT_LINE( 'V1 = ' || V1 );
END;
/
```

Procedure created.

# Compatibility

The SQL standard does not define the following clauses.

**Table 29-4** SQL standard compatibility

Feature ID	Description	Compatibility
T471	Result sets return value	X
T341	Overloading of SQL-invoked functions and SQL-invoked procedures	X
S023	Basic structured types	X
S241	Transform functions	X
S024	Enhanced structured types	X
T571	Array-returning external SQL-invoked functions	X
T572	Multiset-returning external SQL-invoked functions	X
S201	SQL routines on arrays	X
S202	SQL-invoked routines on multisets	X
T323	Explicit security for external routines	X
S231	Structured type locators	X
S232	Array locators	X
S233	Multiset locators	X
T041	Basic LOB data type support	X
S027	Create method by specific method name	X
T041	Basic LOB data type support	X
T324	Explicit security for SQL routines	O
T326	Table functions	X
T651	SQL-schema statements in SQL routines	X
T652	SQL-dynamic statements in SQL routines	O
T653	SQL-schema statements in external routines	X
T654	SQL-dynamic statements in external routines	X
T655	Cyclically dependent routines	X
T272	Enhanced savepoint management	X
T522	Default values for IN parameters of SQL-invoked procedures	O
B121	Routine language Ada	X
B122	Routine language C	X
B123	Routine language COBOL	X
B124	Routine language Fortran	X
B125	Routine language MUMPS	X
B126	Routine language Pascal	X
B127	Routine language PL/I	X
B128	Routine language SQL	O
B129	Routine language Ada: VARCHAR and NUMERIC support	X



## For More Information

Refer to the followings.

- [DROP PROCEDURE](#)
- [ALTER PROCEDURE](#)

## 29.9 DROP FUNCTION

### Function

It drops a function.

### Syntax

```
<drop function statement> ::=  
    DROP FUNCTION [ IF EXISTS ] func_name  
    ;
```

### Invocation and Access Rules

One of the following privilege is required to perform <drop function statement>.

- The owner of that function
- (DROP PROCEDURE or CONTROL SCHEMA) ON SCHEMA for the schema to which the function belongs
- DROP ANY PROCEDURE ON DATABASE

### Syntax Rules and Parameters

#### IF EXISTS

Even when the function does not exist, an error does not occur.

#### FUNC NAME

It is the function name to be dropped.

It can define the schema to which the function belongs, such as schema\_name.func\_name. If schema\_name is omitted, the default schema name of the user performing the statement is used.

## Description

It drops a specified schema-level function.

## Examples

```
gSQL> CREATE OR REPLACE FUNCTION FUNC1
RETURN INTEGER
IS
    V1 INTEGER;
BEGIN
    V1 := 10;
    RETURN V1;
END;
/
```

Function created.

```
COMMIT;
```

Commit complete.

```
gSQL> DROP FUNCTION FUNC1;
```

Function dropped.

## Compatibility

The SQL standard does not define the following clauses.

**Table 29-5** SQL standard compatibility

Feature ID	Description	Compatibility
F032	CASCADE drop behavior	X
S024	Enhanced structured types	X

## For More Information

Refer to the followings.

- **CREATE FUNCTION**

- ALTER FUNCTION

## 29.10 DROP PACKAGE

### Function

It drops a package (of only body or both spec/ body).

### Syntax

```
<drop package statement> ::=  
    DROP PACKAGE [BODY] [ IF EXISTS ] package_name  
    ;
```

### Invocation and Access Rules

One of the following privilege is required to perform <drop package statement>.

- The owner of that package
- (DROP PACKAGE or CONTROL SCHEMA) ON SCHEMA for the schema to which the package belongs
- DROP ANY PACKAGE ON DATABASE

### Syntax Rules and Parameters

#### BODY

It drops only the body object in the package of the given name. If the keyword *BODY* is not specified it drops both the package specification and the body.

#### IF EXISTS

Even when the package does not exist, an error does not occur.

## PACKAGE NAME

It is the package name to be dropped.

It can define the schema to which the package belongs, such as `schema_name.package_name`. If `schema_name` is omitted, the default schema name of the user performing the statement is used.

## Description

It drops the specified package object.

## Examples

```
CREATE PACKAGE PKG1
  IS
  V1 INTEGER;
  FUNCTION FUNC1 (A1 INTEGER) RETURN INTEGER;
END;
/
Package created.
DROP PACKAGE IF EXISTS PKG1;
Package dropped.
```

## Compatibility

It is DRO MODULE statement in the SQL standard.

## For More Information

Refer to the followings.

- CREATE PACKAGE
- CREATE PACKAGE BODY
- ALTER PACKAGE

## 29.11 DROP PROCEDURE

### Function

It drops a procedure.

### Syntax

```
<drop procedure statement> ::=  
    DROP PROCEDURE [ IF EXISTS ] proc_name  
    ;
```

### Invocation and Access Rules

One of the following privilege is required to perform <drop procedure statement>.

- The owner of that procedure
- (DROP PROCEDURE or CONTROL SCHEMA) ON SCHEMA for the schema to which the procedure belongs
- DROP ANY PROCEDURE ON DATABASE

### Syntax Rules and Parameters

#### IF EXISTS

Even when the procedure does not exist, an error does not occur.

#### PROC NAME

It is the procedure name to be dropped.

It can define the schema to which the procedure belongs, such as schema\_name.proc\_name. If schema\_name is omitted, the default schema name of the user performing the statement is used.

## Description

It drops a specified schema-level procedure.

## Examples

```
gSQL> CREATE OR REPLACE PROCEDURE PROC1( A1 INTEGER, A2 INTEGER )
IS
  V1 INTEGER;
BEGIN
  SELECT COUNT(*)
  INTO V1
  FROM T1
  WHERE T1.I1 >= A1 AND T1.I1 <= A2;
  DBMS_OUTPUT.PUT_LINE( 'V1 = ' || V1 );
END;
/
```

Procedure created.

```
COMMIT;
```

Commit complete.

```
gSQL> DROP PROCEDURE PROC1;
```

Procedure dropped.

## Compatibility

The SQL standard does not define the following clauses.

**Table 29-6** SQL standard compatibility

Feature ID	Description	Compatibility
F032	CASCADE drop behavior	X
S024	Enhanced structured types	X



## For More Information

Refer to the followings.

- [CREATE PROCEDURE](#)
- [ALTER PROCEDURE](#)



# Part V.

---

# Developer Manual

<b>30. Database Connection</b>	<b>3,015</b>
30.1 Features	3,016
30.2 Selecting Execution Member	3,017
30.3 Global Session	3,019
30.4 Constraints	3,020
Session Dependent Object	3,021
Session Dependent Clause	3,021
Session Dependent Function and Pseudo Column	3,021
When Using Global Session	3,022
30.5 Settings	3,022
<b>31. ODBC</b>	<b>3,023</b>
31.1 Overview of GOLDILOCKS ODBC Driver	3,024
Concepts of GOLDILOCKS ODBC Driver	3,024
Overview of ODBC Components	3,024
Using GOLDILOCKS ODBC Driver	3,025
31.2 Data Source Configuration	3,027
DSN Configuration on UNIX	3,027
DSN Configuration on Windows	3,034
31.3 GLOBAL CONNECTION	3,038
Settings	3,038
Processing GLOBAL CONNECTION	3,039
Handling GLOBAL CONNECTION Exception	3,041
Constraints of GLOBAL CONNECTION	3,044
31.4 Catalog Function	3,046
Using Catalog Data	3,046
Catalog Function on ODBC	3,047
31.5 ODBC API References	3,051
SQLAllocConnect	3,051
SQLAllocEnv	3,052
SQLAllocHandle	3,053
SQLAllocStmt	3,056
SQLBindCol	3,057
SQLBindParameter	3,065
SQLBrowseConnect	3,080
SQLBulkOperations	3,081
SQLCancel	3,082
SQLCancelHandle	3,083
SQLCloseCursor	3,084
SQLColAttribute	3,086

SQLColAttributes	3,092
SQLColumnPrivileges	3,093
SQLColumns	3,097
SQLConnect	3,102
SQLCopyDesc	3,104
SQLDescribeCol	3,105
SQLDescribeParam	3,108
SQLDisconnect	3,110
SQLDriverConnect	3,112
SQLEndTran	3,116
SQLError	3,118
SQLExecDirect	3,119
SQLExecute	3,123
SQLExtendedFetch	3,126
SQLFetch	3,127
SQLFetchScroll	3,135
SQLForeignKeys	3,142
SQLFreeConnect	3,148
SQLFreeEnv	3,149
SQLFreeHandle	3,150
SQLFreeStmt	3,152
SQLGetConnectAttr	3,154
SQLGetConnectOption	3,158
SQLGetCursorName	3,159
SQLGetData	3,161
SQLGetDescField	3,167
SQLGetDescRec	3,183
SQLGetDiagField	3,187
SQLGetDiagRec	3,196
SQLGetEnvAttr	3,199
SQLGetFunctions	3,203
SQLGetGroupCount	3,208
SQLGetGroupIDs	3,210
SQLGetGroupName	3,212
SQLGetInfo	3,214
SQLGetStmtAttr	3,225
SQLGetStmtOption	3,237
SQLGetSuitableGroupID	3,238
SQLGetTypeInfo	3,240

SQLMoreResults	3,247
SQLNativeSql	3,251
SQLNumParams	3,252
SQLNumResultCols	3,255
SQLParamData	3,258
SQLParamOptions	3,260
SQLPrepare	3,261
SQLPrimaryKeys	3,267
SQLProcedureColumns	3,272
SQLProcedures	3,279
SQLPutData	3,284
SQLRowCount	3,289
SQLSetConnectAttr	3,292
SQLSetConnectOption	3,301
SQLSetCursorName	3,302
SQLSetDescField	3,305
SQLSetDescRec	3,328
SQLSetEnvAttr	3,333
SQLSetParam	3,337
SQLSetPos	3,338
SQLSetScrollOptions	3,351
SQLSetStmtAttr	3,352
SQLSetStmtOption	3,366
SQLSpecialColumns	3,367
SQLStatistics	3,374
SQLTablePrivileges	3,381
SQLTables	3,387
SQLTransact	3,393
31.6 XA API References	3,394
Overview	3,394
XA Interface	3,395
Example	3,406
<b>32. JDBC</b>	<b>3,411</b>
32.1 Overview of GOLDILOCKS JDBC Driver	3,412
Concepts of GOLDILOCKS JDBC Driver	3,412
Characteristics	3,412
Supporting Versions	3,414
Examples	3,415
32.2 Feature Specification	3,417

Connection	3,417
Data Manipulation	3,423
Data Retrieval	3,427
ResultSet Scroll	3,429
Using Other Data Types	3,431
Logging	3,434
Viewing Plan Text	3,436
Connection Failover	3,437
Connecting in Direct Attach Mode	3,440
Global Connection	3,441
Statement Pooling	3,445
32.3 JDBC API References	3,449
Array	3,449
Blob	3,451
CallableStatement	3,454
Clob	3,473
CommonDataSource	3,476
Connection	3,481
ConnectionPoolDataSource	3,492
DatabaseMetaData	3,493
DataSource	3,526
Driver	3,527
NClob	3,529
ParameterMetaData	3,531
PooledConnection	3,534
PreparedStatement	3,536
Ref	3,549
ResultSet	3,550
ResultSetMetaData	3,588
RowId	3,593
RowSet	3,594
RowSetMetaData	3,604
Savepoint	3,607
SQLData	3,608
SQLXML	3,609
Statement	3,611
Struct	3,621
XAConnection	3,622
XADataSource	3,623

XAResource	3,624
GoldilocksInterval	3,626
GOLDILOCKS Type	3,637
Type Conversion	3,637
<b>33. Embedded SQL</b>	<b>3,643</b>
33.1 Precompiler	3,644
Overview	3,644
Building Application	3,645
Precompiler Options	3,649
33.2 Embedded SQL	3,655
Preprocessing	3,655
Connection	3,661
Transaction	3,663
Host Variables and Datatypes	3,665
Embedded SQL	3,717
Options	3,739
Host Array	3,740
Handling Run-time Errors	3,756
33.3 Advanced Topic	3,770
Embedded Dynamic SQL	3,770
Multithread Application	3,784
Multi-process Application	3,796
C++ Application	3,796
XA	3,797
33.4 Embedded SQL Reference	3,812
EXEC SQL AT	3,813
EXEC SQL ATOMIC INSERT	3,814
EXEC SQL AUTOCOMMIT	3,816
EXEC SQL BEGIN DECLARE SECTION	3,817
EXEC SQL COMMIT RELEASE	3,818
EXEC SQL CONNECT	3,820
EXEC SQL CONTEXT ALLOCATE	3,822
EXEC SQL CONTEXT FREE	3,824
EXEC SQL CONTEXT USE	3,826
EXEC SQL DISCONNECT	3,828
EXEC SQL END DECLARE SECTION	3,829
EXEC SQL FOR	3,830
EXEC SQL GET GROUPID INTO	3,832
EXEC SQL INCLUDE	3,834



EXEC SQL INCLUDE SQLCA .....	3,835
EXEC SQL OPTION .....	3,836
EXEC SQL ROLLBACK RELEASE .....	3,837
EXEC SQL WHENEVER .....	3,839
<b>34. PDO .....</b>	<b>3,841</b>
34.1 Overview of PDO .....	3,842
34.2 Installation /Configuration .....	3,842
Requirement .....	3,842
Installation .....	3,842
34.3 Usage .....	3,844
Data Source Name (DSN) .....	3,844
34.4 Examples .....	3,845
<b>35. PyDBC .....</b>	<b>3,855</b>
35.1 GOLDILOCKS PyDBC .....	3,856
Overview .....	3,856
Version .....	3,856
Installation .....	3,856
Examples .....	3,857
35.2 API Reference .....	3,859
pygoldilocks Module .....	3,859
Connection .....	3,862
Cursor .....	3,864
Row .....	3,872
35.3 Exception .....	3,874
35.4 Data Type .....	3,875
Transferring Python Parameter to GOLDILOCKS .....	3,875
SQL Value Received from GOLDILOCKS .....	3,876
<b>36. Hibernate .....</b>	<b>3,879</b>
36.1 Overview .....	3,880
36.2 Interworking with Hibernate .....	3,880
Downloading Hibernate .....	3,880
Interworking with GoldilocksDialect Class .....	3,880
36.3 Examples .....	3,882
Configuration .....	3,882
Examples of Application .....	3,883



**30.**

---

## **Database Connection**

# 30.1 Features

Figure 1 GLOBAL CONNECTION

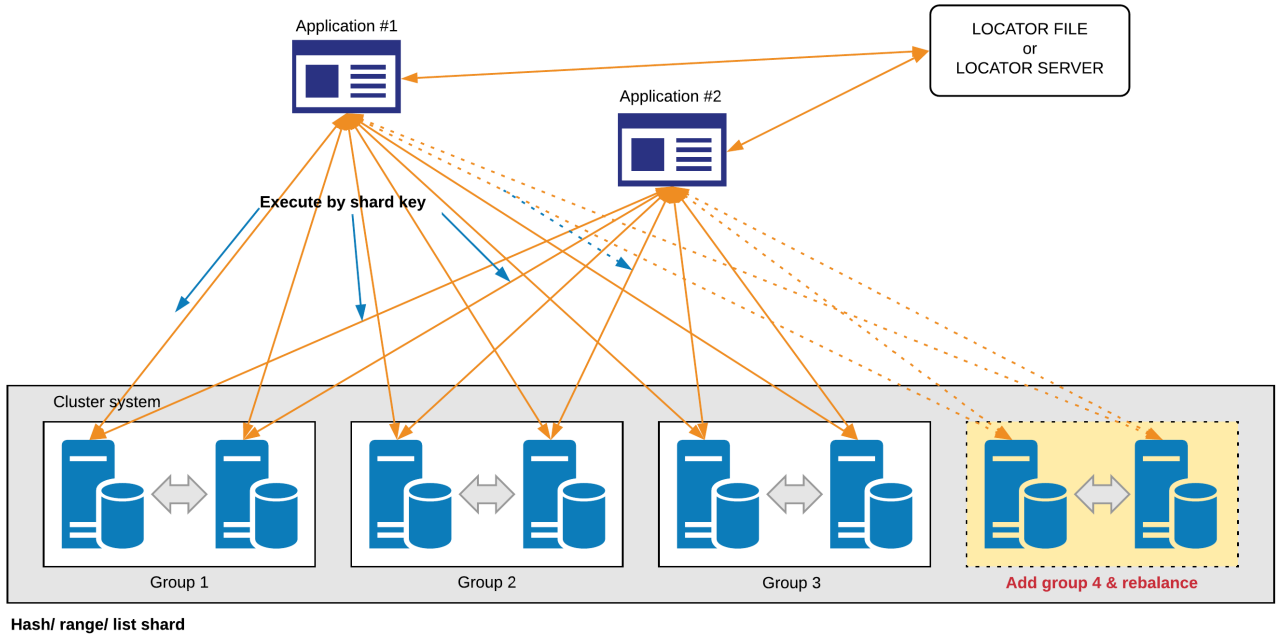

Global connection feature is a method of optimizing transaction performance in consideration of data locality.

A general connection is a connection with a single member, but global connection is a connection with all members. An application using the global connection makes the member with most data accessed by queries perform the query, so the performance is upgraded.

Hash, range, list sharding method can use the global connection, and the application does not need to be altered at that moment.

When the online scale-out is performed, a user does not need to consider a new node but the application automatically connects to a new node and operates it.

Figure 2 GLOBAL CONNECTION HA (high availability)

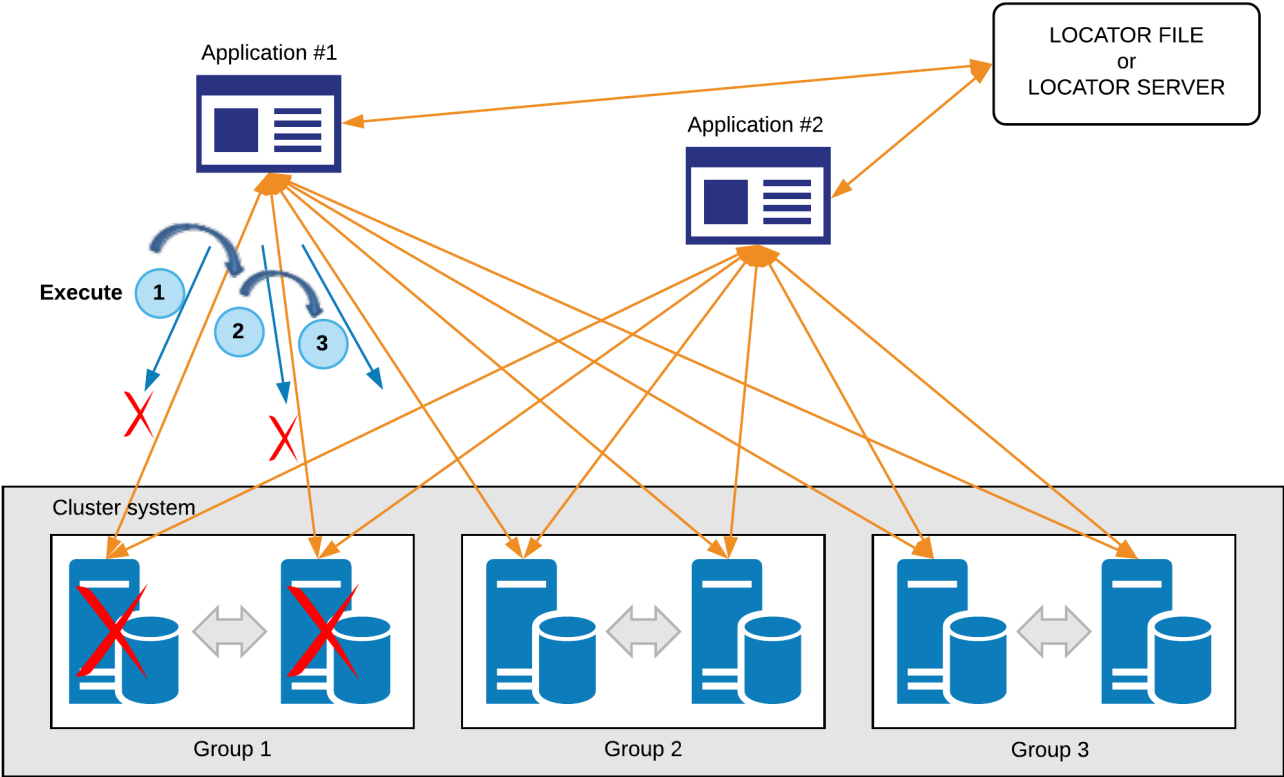

If an error occurs on the selected node when performing SQL, then the SQL is performed through another node in the same group. If errors occur on all nodes in the selected group, then the SQL is performed through another group.

When a node is recovered from an error, it is automatically connected to the node again online. Moreover, a user can make an application connect again by using the following syntax.

```
ALTER SYSTEM RECONNECT GLOBAL CONNECTION
```

## 30.2 Selecting Execution Member

An execution member is selected per transaction. When DML query is first performed without a transaction, a group is selected according to the sharding key, and an execution member in the group is selected according to LOCALITY\_MEMBER\_POLICY property. Then, all queries are processed in the selected member until COMMIT or ROLLBACK. If the first query can not select the appropriate group according to a sharding key, then the group is selected according to LOCALITY\_GROUP\_POLICY property.

Figure 3 Selecting a member

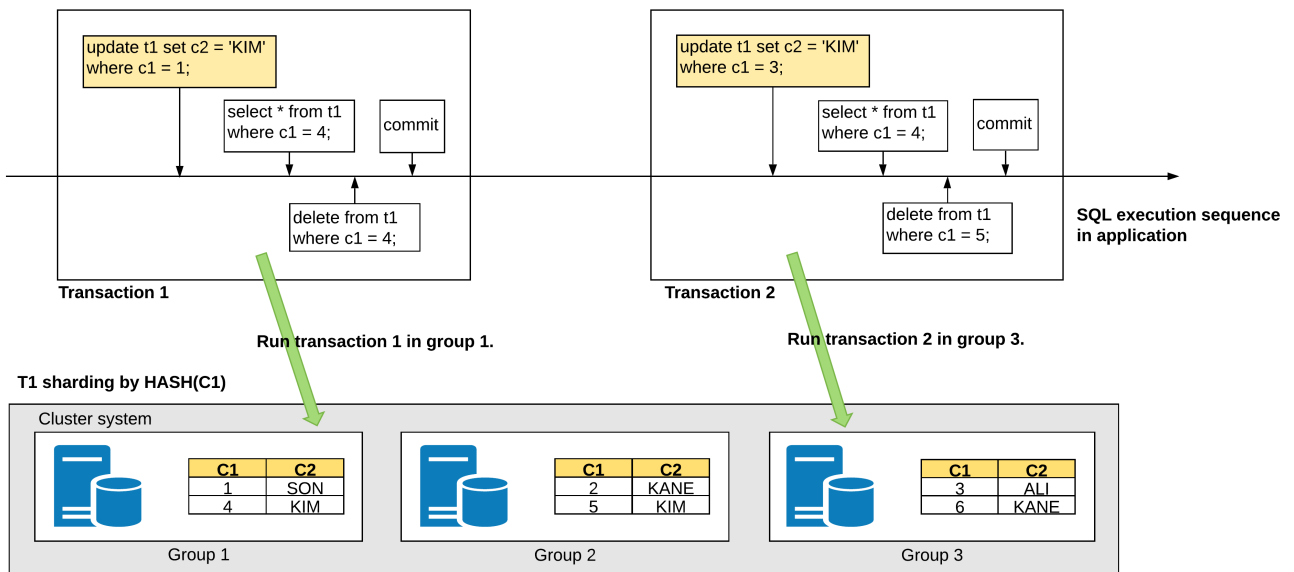

In case of transaction1 in the figure above, UPDATE query is performed in the group1 according to the sharding key, so all queries between COMMITs are performed in group1. In case of transaction2, UPDATE query is performed in group3, and all queries are performed in group3 before COMMIT even when further queries are not appropriate to perform in group3.

The read-only query (SELECT) without a transaction selects an execution member according to a sharding key like as other queries, but further queries are not always performed in the previously selected member.

In other words, all queries included in a transaction is performed only in a single member, but a query irrelevant to a transaction selects a member per a member.

## 30.3 Global Session

Figure 4 Cluster session derived from global connection

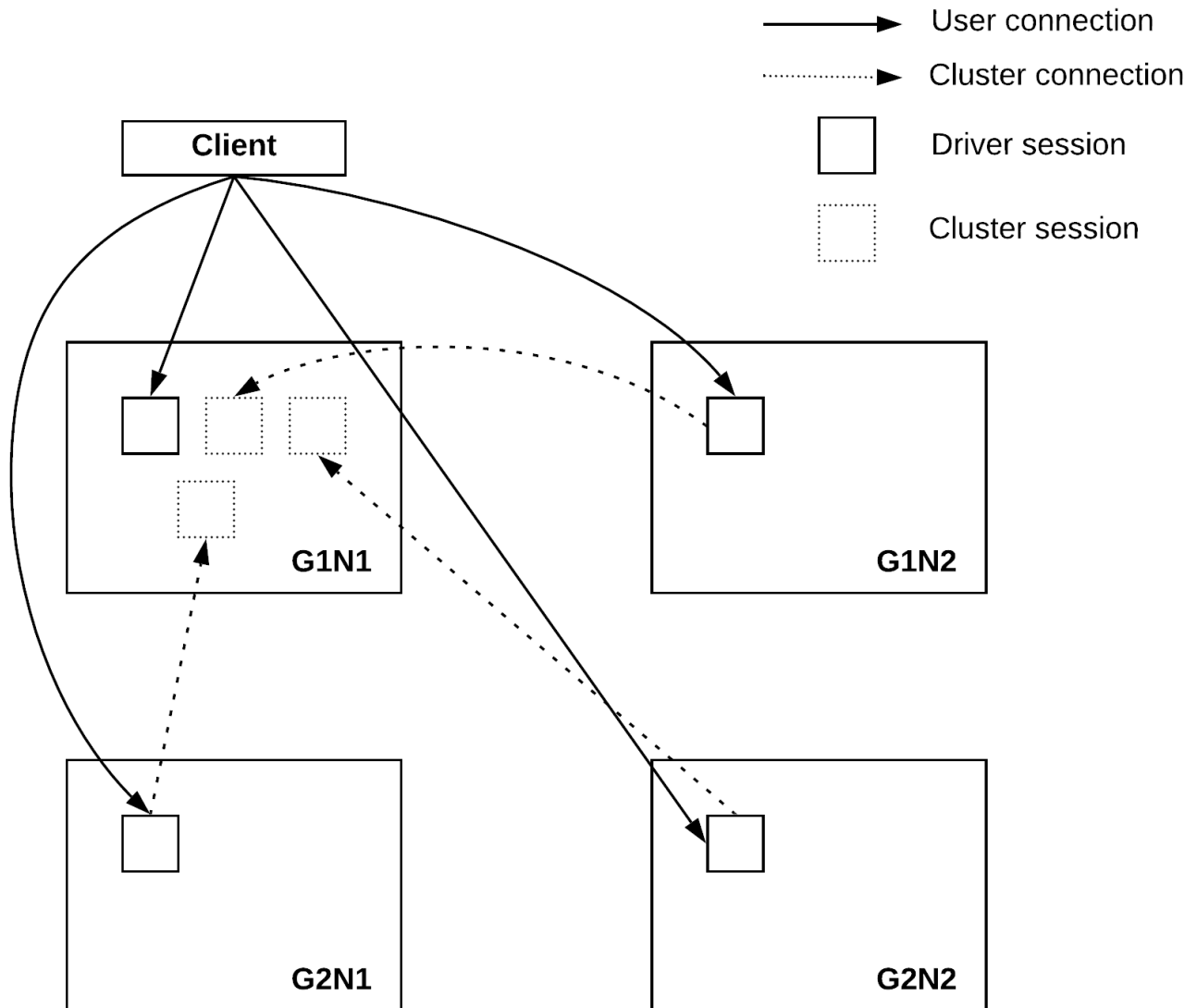

The session directly connected to an application is called as a driver session, and a session from a driver session to another member is called as a cluster session. Global connection creates a driver session in all members, and creates cluster sessions in another member when it is needed. Global connection can make multiple cluster sessions in a single member.

Figure 5 Global session

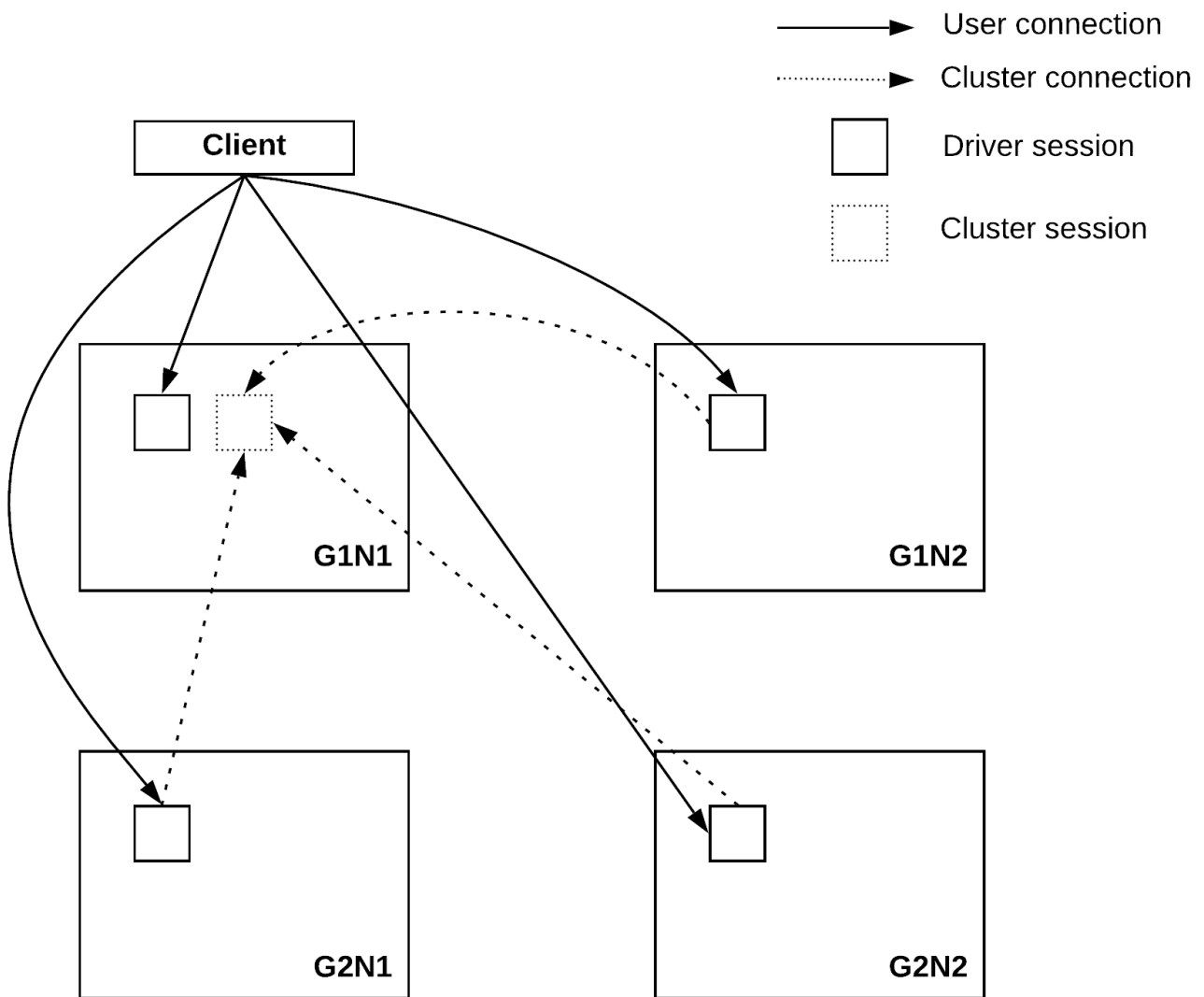

Global session is a feature for a cluster sessions created in the global connection shares a single session to improve the resource efficiency. When the global connection does not use a global session, then the cluster session increases according to increasing groups and members. However, when it uses the global session, then the cluster session does not increase even when groups and members increase.

The global session feature is available only in the global connection, but it is not available in the general connection.

## 30.4 Constraints

When using the global connection, a session dependent object is not available in SQL statement, a session dependent clause nor is a session dependent function available.



Also, if SQLs accessing to multiple cluster nodes exist in a single transaction, then SQLs in the transaction uses the cluster node in common which were selected by the sharding key of the first SQL.

The query in the global connection is performed in consideration of data locality only when it is performed with prepare execute. However, it is performed in an arbitrary node when it is performed with direct execute.

## Session Dependent Object

When using a session dependent object in SQL statement, the global connection is not available.

- Global temporary table

## Session Dependent Clause

When using a session dependent clause in SQL statement, the global connection is not available.

- All @domain-related statements

## Session Dependent Function and Pseudo Column

When using session dependent information in SQL statement, the global connection is not available.

- CURRVAL(sequence), sequence.CURRVAL
- UUID()
- VERSION()
- SESSION\_ID()
- SESSION\_SERIAL()
- USER\_ID()
- LAST\_IDENTITY\_VALUE()
- STATEMENT\_VIEW\_SCN()
- STATEMENT\_VIEW\_SCN\_GCN()
- STATEMENT\_VIEW\_SCN\_DCN()
- STATEMENT\_VIEW\_SCN\_LCN()
- LOCAL\_GROUP\_ID()
- LOCAL\_MEMBER\_ID()
- LOCAL\_GROUP\_NAME()

- LOCAL\_MEMBER\_NAME()
- CLUSTER\_GROUP\_ID
- CLUSTER\_GROUP\_NAME
- CLUSTER\_MEMBER\_ID
- CLUSTER\_MEMBER\_NAME
- CLUSTER\_SHARD\_ID

## When Using Global Session

Data Definition Language (DDL) is not available in SQL statement.

## 30.5 Settings

For more information, refer to the followings.

- [Setting global connection in ODBC](#)
- [Setting global connection in JDBC](#)

**31.**

---

**ODBC**

## 31.1 Overview of GOLDILOCKS ODBC Driver

### Concepts of GOLDILOCKS ODBC Driver

Open Database Connectivity (ODBC) is a specifications for a database Application Programming Interface (API). Microsoft ODBC version 3.0 is based on International Standards Organization/ International Electro mechanical Commission (ISO/ IEC) and the recommended specifications of Call Level Interface (CLI) of X/ open. ODBC supports the SQL statements by using C library functions. The application implements the ODBC features by calling these functions.

ODBC architecture has four components which perform the following features.

Component	Description
Application	It calls ODBC function which communicated with an ODBC data source and sends an SQL statement and processes the result set.
Driver manager	It manages the communication between an application and all ODBC drivers which are used by the application.
Driver	It processes all ODBC calls from applications, and connects to data source, and submits the SQL statement to the data source in the application, and returns results to the application. If necessary, the driver converts the ODBC SQL sent from the application to the default SQL which is used in the data source.
Data source	It includes all information which the driver needs to access the data in the DBMS.

The following operations can be executed by using ODBC applications.

- Connecting to a data source
- Sending SQL statements to the data source
- Processing the results of an SQL statement in the data source
- Handling errors and messages
- Terminating the connection to the data source

### Overview of ODBC Components

#### GOLDILOCKS ODBC Driver Including Driver Manager

The following is a software architecture of when the driver manager is included in the system. In this case, the application should be linked to the driver manager library.

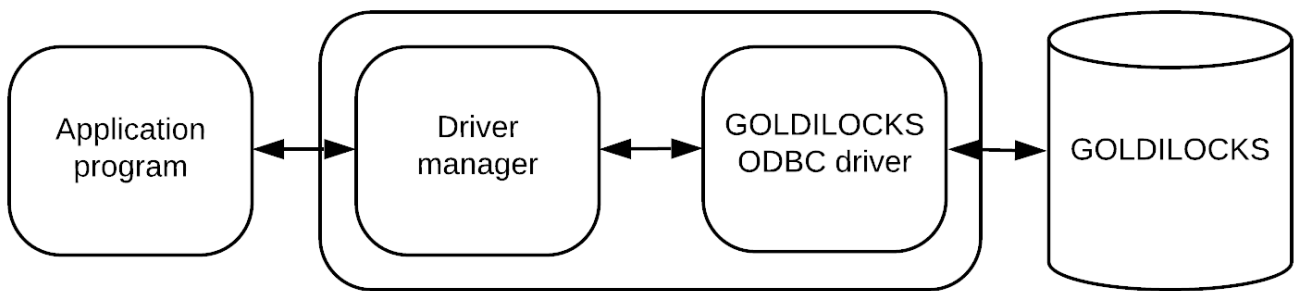
**Figure 1** GOLDILOCKS ODBC driver including the driver manager

## GOLDILOCKS ODBC Driver Not Including Driver Manager

The following is an architecture of when the application does not include a driver manager and uses GOLDILOCKS ODBC driver. In this case, the application should be linked to GOLDILOCKS ODBC driver library.

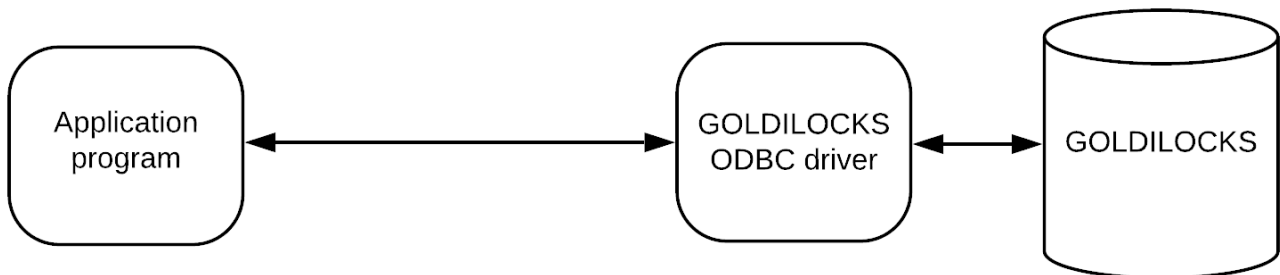
**Figure 2** GOLDILOCKS ODBC driver not including the driver manager

## Using GOLDILOCKS ODBC Driver

### Header File

goldilocks.h file installed on \$GOLDILOCKS\_HOME/include should be included to execute GOLDILOCKS ODBC driver. This file defines constant and type of GOLDILOCKS ODBC driver, and provides a function prototype of GOLDILOCKS ODBC driver function.

### Library

The application which does not use a driver manager should be linked to a static or shared version of GOLDILOCKS ODBC driver library.

### UNIX

**Table 31-1** GOLDILOCKS UNIX ODBC driver libraries

File name	Description
libgoldilocks.a	It is a static version of library including DA and CS.
libgoldilocks.a	It is a static version of DA dedicated library.
libgoldilocksas.so	It is a shared version of DA dedicated library.
libgoldilocksc.a	It is a static version of CS dedicated library.
libgoldilockscs-ul32.so	It is a shared version of 64-bit CS dedicated library recognizing SQLLEN to 4 bytes.
libgoldilockscs-ul64.so	It is a shared version of 64-bit CS dedicated library recognizing SQLLEN to 8 bytes.
libgoldilockscs.so	It is a shared version of 32-bit CS dedicated library.
libgoldilockss.so	It is a shared version of library including DA and CS.

## Windows

GOLDILOCKS Windows ODBC driver libraries provide CS libraries only.

**Table 31-2** GOLDILOCKS Windows ODBC driver libraries

File name	Description
goldilockscs-ul64.dll	It is a shared version of 64-bit CS dedicated library recognizing SQLLEN to 8 bytes.
goldilockscs.dll	It is a shared version of 32-bit CS dedicated library.
goldilockssetup32.dll	It is a setup library for 32-bit ODBC driver manager.
goldilockssetup64.dll	It is a setup library for 64-bit ODBC driver manager.

## 31.2 Data Source Configuration

### DSN Configuration on UNIX

#### odbcinst.ini File

odbcinst.ini file is a configuration file for installed ODBC driver.

- unixODBC

```
% odbcinst -j
unixODBC 2.3.2
DRIVERS.....: /etc/odbcinst.ini
SYSTEM DATA SOURCES: /etc/odbc.ini
FILE DATA SOURCES..: /etc/ODBCDataSources
USER DATA SOURCES..: /home/goldilocks/.odbc.ini
SQLULEN Size.....: 8
SQLLEN Size.....: 8
SQLSETPOSIROW Size.: 8
```

- iODBC

```
% iodbc-config --odbcinstini
/etc/odbcinst.ini
```

#### ODBC Driver Specification

ODBC driver specification section in odbcinst.ini file specifies the driver property values and list. The registered information section is under the driver name in each driver installed.

```
[driver_name]
Description = driver_description
Driver = driver_library_path
Setup = setup_library_path
FileUsage = file_usage
```

The following table describes keywords in the driver specification section.

Keyword	Description
Description	It is a string which describes the driver.

Keyword	Description
Driver	It is a driver library path.
Setup	It is a setup library path.
FileUsage	It is a character which displays how to directly process the file in DSN by the file-based driver.

The following is an example of information of GOLDILOCKS ODBC driver specifications.

```
[GOLDILOCKS ODBC Driver]
Description= GOLDILOCKS ODBC Driver
Driver = /home/goldilocks/home/lib/libgoldilockscs-ul64.so
Setup = /home/goldilocks/home/lib/libgoldilockscs-ul64.so
FileUsage = 0
```

## odbc.ini File

odbc.ini file is the configuration file for the DSN connected by the application, and it is divided into a user DSN and system DSN. Typically, a user DSN file is `~/.odbc.ini` file, and a system DSN file is `/etc/odbc.ini`.

- unixODBC

```
% odbcinst -j
unixODBC 2.3.4
DRIVERS.....: /etc/odbcinst.ini
SYSTEM DATA SOURCES: /etc/odbc.ini
FILE DATA SOURCES..: /etc/ODBCDataSources
USER DATA SOURCES..: /home/goldilocks/.odbc.ini
SQLULEN Size.....: 8
SQLLEN Size.....: 8
SQLSETPOSIROW Size.: 8
```

- iODBC

```
% iodbc-config --odbcini
/etc/odbc.ini
```

## Data Source Specification

Data source specification section of the odbc.ini file describes DSN.

```
[data_source_name]
Driver = driver_name
PROTOCOL = {DA | TCP | IPC}
```



```

CS_MODE = {default | dedicated | shared}
HOST = host_address
PORT = port_no
PREFER_IPV6 = {0 | 1}
CHARSET = {SQL_ASCII | UTF8 | UHC | GB18030}
TCP_NODELAY = {0 | 1}
ALTERNATE_SERVERS = (HOST=ADDRESS1:PORT=PORT1,HOST=ADDRESS2:PORT=PORT2)
CONNECTION_RETRY_COUNT = retry_count
CONNECTION_RETRY_DELAY = retry_delay
FAILOVER_TYPE = {CONNECTION | SESSION}
FAILOVER_GRANULARITY = {0 | 1 | 2}
FAILOVER_ROUTING_POLICY = {0 | 1}
DATE_FORMAT = date_format_string
TIME_FORMAT = time_format_string
TIME_WITH_TIME_ZONE_FORMAT = timetz_format_string
TIMESTAMP_FORMAT = timestamp_format_string
TIMESTAMP_WITH_TIME_ZONE_FORMAT = timestamptz_format_string
CHAR_LENGTH_UNITS = {BYTE | OCTETS | CHAR | CHARACTERS}
ENABLE_SQLDESCRIBEPARAM = {0 | 1}
ENABLE_SQLBINDPARAMETER_CONSISTENCY_CHECK = {0 | 1}
USE_TARGETTYPE = {0 | 1 | 2}
LOCATOR_DSN = locator_dsn_name
LOCATOR_SERVICE = locator_service_name
LOCALITY_AWARE_TRANSACTION = {0 | 1}
LOCALITY_GROUP_POLICY = {0 | 1 | 2}
LOCALITY_GROUP_PATH = group_name1, group_name2, group_name3
LOCALITY_MEMBER_POLICY = {0 | 1 | 2 | 3 | 4}
LOCALITY_MEMBER_PATH = member_name1,member_name2, member_name3
DB_HOME = database_home_path
PACKET_COMPRESSION_THRESHOLD = packet_compression_threshold
USE_GLOBAL_SESSION = {0 | 1}
CONNECTION_TIMEOUT = connection_timeout
LOGIN_TIMEOUT = login_timeout
TRACE = {0 | 1}
TRACEFILE = file_path_name
TRACE_POLICY={DEFAULT | ERROR}
INCLUDE_SYNONYMS = {0 | 1}
DOT_NET_FOR_ODBC = {0 | 1}
[locator_dsn_name]
FILE = location_file_name
HOST = IP address(v4)

```

```

PORT = locator_port
CONNECTION_TIMEOUT = second
ALTERNATE_LOCATORS = (HOST=ADDRESS1:PORT=PORT1,HOST=ADDRESS2:PORT=PORT2)

```

The following table describes keywords in the data source specification section.

**Table 31-3** Keywords in the data source specification section

Keyword	Description
data_source_name	It is the data source specified in the data source section.
Driver	It is a driver name installed on odbcinst.ini.
PROTOCOL	It is a connection type with the server. <ul style="list-style-type: none"> <li>• DA: It directly accesses to the server without communication.</li> <li>• TCP: It communicates with the server through TCP socket.</li> <li>• IPC: It communicates with the server through the shared memory, and it is available only in the same device of the server. It uses TCP connection to transfer IPC information when accessing for the first time, so HOST and PORT should be set. It can access the server only in dedicated mode.</li> </ul>
CS_MODE	It sets whether to connect as dedicated mode or shared mode. If it is not set, the default mode is determined depending on the configuration (DEFAULT_CS_MODE) of the listener.
HOST	It is a host IP address or a host name.
PORT	It is a connection port number.
PREFER_IPV6	If the host parameter is the host name, then IPv6 takes precedence over other IP addresses.
TCP_NODELAY	It is a socket TCP_NODELAY option.
UID	It is a user ID.
PWD	It is a user password.
CHARSET	It is a client character set.
ALTERNATE_SERVERS	It is a server list which attempts to connect when the failover occurs. Each servers is separated by a comma (.). To disable the failover feature, set ALTERNATE_SERVERS as a white space.
CONNECTION_RETRY_COUNT	It is the number of times which the driver attempts to connect to the server when the connection fails.
CONNECTION_RETRY_DELAY	It is the server connection retry interval (in seconds) when the connection fails.
FAILOVER_TYPE	<ul style="list-style-type: none"> <li>• CONNECTION: When the connection fails, it is connected to ALTERNATE_SERVERS.</li> <li>• SESSION: When the connection fails or the connection is disconnected during operating the statement, it is connected to ALTERNATE_SERVERS and the statement is restored. The statement is executed after the failover if the connection is disconnected when a transaction is not in progress.</li> </ul>
FAILOVER_GRANULARITY	<ul style="list-style-type: none"> <li>• 0: The failover proceeds even when an error occurs.</li> <li>• 1: The failover fails when an error except for SQLExecute (), SQLExecDirect ()occ</li> </ul>

Keyword	Description
	<p>urs during the failover).</p> <ul style="list-style-type: none"> <li>• 2: The failover fails when an error occurs.</li> </ul>
FAILOVER_ROUTING_POLICY	<ul style="list-style-type: none"> <li>• 0: If an error occurs in the last server of ALTERNATE_SERVERS, then the failover starts again from the primary server.</li> <li>• 1: If an error occurs in the last server of ALTERNATE_SERVERS, then the failover ends.</li> </ul>
DATE_FORMAT	It is a DATE type string.
TIME_FORMAT	It is a TIME type string.
TIME_WITH_TIME_ZONE_FORMAT	It is a TIME WITH TIME ZONE type string.
TIMESTAMP_FORMAT	It is a TIMESTAMP type string.
TIMESTAMP_WITH_TIME_ZONE_FORMAT	It is a TIMESTAMP WITH TIME ZONE type string.
CHAR_LENGTH_UNITS	<p>It is the unit of ColumnSize when ParameterType in SQLBindParameter() is SQL_CHAR, SQL_VARCHAR.</p> <ul style="list-style-type: none"> <li>• BYTE, OCTETS: Byte unit</li> <li>• CHAR, CHARACTERS: Character unit</li> </ul>
ENABLE_SQLDESCRIBEPARAM	<p>It determines whether to enable SQLDescribeParam().</p> <ul style="list-style-type: none"> <li>• 0: The driver does not support SQLDescribeParam().</li> <li>• 1: The driver returns SQL_VARCHAR for all parameters.</li> </ul>
ENABLE_SQLBINDPARAMETER_CONSISTENCY_CHECK	<p>It determines whether to check ColumnSize and DecimalDigits in SQLBindParameter().</p> <ul style="list-style-type: none"> <li>• 0: It does not check ColumnSize and DecimalDigits.</li> <li>• 1: It checks ColumnSize and DecimalDigits.</li> </ul>
USE_TARGETTYPE	<p>It sets the type information which is to be received together when receiving a column type through communication.</p> <ul style="list-style-type: none"> <li>• 0: It receives only the column type.</li> <li>• 1: It receives the column type and column name.</li> <li>• 2: It receives the column type and all information about the column.</li> </ul>
LOCATOR_DSN	It is Data Source Name (DSN) which specifies a location information.
LOCATOR_SERVICE	It gets the connection information from a service hint and locator.
LOCALITY_AWARE_TRANSACTION	<p>It determines whether to use GLOBAL CONNECTION.</p> <ul style="list-style-type: none"> <li>• 0: It does not use GLOBAL CONNECTION.</li> <li>• 1: It uses GLOBAL CONNECTION.</li> </ul>
LOCALITY_GROUP_POLICY	<p>It determines how to select a group if neither of groups are available, or two or more groups are available when using GLOBAL CONNECTION.</p> <ul style="list-style-type: none"> <li>• 0: It randomly selects the group.</li> <li>• 1: It sequentially selects groups which exist in LOCALITY_GROUP_PATH setting. If neither of groups in LOCALITY_GROUP_PATH are not available, it randomly selects the group.</li> <li>• 2: It sequentially selects groups. It always selects groups in an order of they are connected to the driver.</li> </ul>

Keyword	Description
LOCALITY_GROUP_PATH	It defines the list of selected groups when the available group is not a single one when using GLOBAL CONNECTION. Each group is distinguished with comma (,). e.g. G1,G2,G3
LOCALITY_MEMBER_POLICY	It determines how to select a member in the selected group when using GLOBAL CONNECTION. <ul style="list-style-type: none"> <li>0: DML : MASTER / SELECT : MASTER</li> <li>1: DML : ANY / SELECT : ANY</li> <li>2: DML : MASTER / SELECT : ANY</li> <li>3: DML : MASTER / SELECT : SLAVE</li> <li>4: It sequentially selects members which exist in LOCALITY_MEMBER_PATH setting. If neither of members in LOCALITY_MEMBER_PATH are not available, it uses the MASTER in the selected group.</li> </ul>
LOCALITY_MEMBER_PATH	It defines the list of members to be used in the selected group when using GLOBAL CONNECTION. Each member is distinguished with comma (,). e.g. G1N1,G2N1,G3N1,G1N2,G2N2,G3N2
DB_HOME	It sets the home directory of the database. The default value uses \$GOLDILOCKS_HOME environment variable.
PACKET_COMPRESSION_THRESHOLD	It compresses the communication data when the size of the communication data to be sent to the server is bigger than PACKET_COMPRESSION_THRESHOLD. The range of the set value is 32 ~ 2113929216.
USE_GLOBAL_SESSION	It is whether to use GLOBAL SESSION. <ul style="list-style-type: none"> <li>0: It does not use GLOBAL SESSION.</li> <li>1: uses GLOBAL SESSION.</li> </ul>
CONNECTION_TIMEOUT	It is waiting time (in seconds) for the response after the request.
LOGIN_TIMEOUT	It is waiting time (in seconds) for the login request to be completed.
TRACE	It sets whether to use trace in ODBC API. <ul style="list-style-type: none"> <li>0: It does not use the trace.</li> <li>1: It uses the trace.</li> </ul>
TRACEFILE	It is the name of the trace file. When the relative path is input, then it is based on the directory in which the program currently runs. The default value is 'odbc_trace.log'.
INCLUDE_SYNONYMS	It sets whether to include the synonym object in SQLGetColumns(). <ul style="list-style-type: none"> <li>0: It does not include the synonym object.</li> <li>1: It includes the synonym object.</li> </ul>
DOT_NET_FOR_ODBC	It is whether to use ODBC for .NET Framework. <ul style="list-style-type: none"> <li>0: It does not change its usage.</li> <li>1: It replaces SQL_DESC_BASE_COLUMN_NAME, SQL_DESC_NAME properties, in SQLGetDescField() and SQLColAttribute() with SQL_DESC_LABEL property.</li> </ul>

Table 31-4 Location

Keyword	Description
FILE	Location file name

Keyword	Description
HOST	glocator ip address
PORT	glocator port number
CONNECTION_TIMEOUT	Connection timeout with glocator (second)
ALTERNATE_LOCATORS	If glocator does not respond, it gets the connection information by using ALTERNATE_LOCATORS.



- If properties of FILE, HOST, PORT are all set in LOCATOR\_DSN, then the FILE property is prior to others. For more information, refer to **Location File**.
- LOCATOR\_SERVICE property enables to connect to a server belonging to LOCATOR\_SERVICE. Servers other than the connected server become ALTERNATE\_SERVERS.  
If FAILOVER\_TYPE is not set, then FAILOVER\_TYPE is a session.  
If FAILOVER\_GRANULARITY is not set, then FAILOVER\_GRANULARITY is 1.  
For more information, refer to **glocator** and **gloctl**.

The following is an example of DSN configuration of GOLDILOCKS.

```
[GOLDILOCKS]
Driver = GOLDILOCKS ODBC Driver
PROTOCOL = TCP
CS_MODE = SHARED
HOST = 192.168.0.10
PORT = 22581
CHARSET = UTF8
TCP_NODELAY = 1
ALTERNATE_SERVERS = (HOST=192.168.0.11:PORT=22581,HOST=192.168.0.12:PORT=22581)
CONNECTION_RETRY_COUNT = 3
CONNECTION_RETRY_DELAY = 1
FAILOVER_TYPE = SESSION
FAILOVER_GRANULARITY = 0
FAILOVER_ROUTING_POLICY = 0
DATE_FORMAT = YYYY-MM-DD
TIME_FORMAT = HH24:MI:SS.FF6
TIME_WITH_TIME_ZONE_FORMAT = HH24:MI:SS.FF6 TZH:TZM
TIMESTAMP_FORMAT = YYYY-MM-DD HH24:MI:SS.FF6
TIMESTAMP_WITH_TIME_ZONE_FORMAT = YYYY-MM-DD HH24:MI:SS.FF6 TZH:TZM
CHAR_LENGTH_UNITS = CHARACTERS
ENABLE_SQLDESCRIBEPARAM = 1
```

```
ENABLE_SQLBINDPARAMETER_CONSISTENCY_CHECK = 1
USE_TARGETTYPE = 0
INCLUDE_SYNONYMS = 0
PACKET_COMPRESSION_THRESHOLD = 2113929216
LOCALITY_AWARE_TRANSACTION = 0
LOCALITY_GROUP_POLICY = 0
LOCALITY_GROUP_PATH = G1,G2,G3
LOCALITY_MEMBER_POLICY = 0
LOCALITY_MEMBER_PATH = G1N1,G2N1,G3N1,G1N2,G2N2,G3N2
USE_GLOBAL_SESSION = 0
CONNECTION_TIMEOUT = 0
LOGIN_TIMEOUT = 0
LOCATOR_DSN = LOCATOR
LOCATOR_SERVICE = S1
TRACE = 1
TRACEFILE = /home/test/log/mytrace.log
DOT_NET_FOR_ODBC = 0
[LOCATOR]
FILE = /home/test/.location.ini
HOST = 127.0.0.1
PORT = 42581
ALTERNATE_LOCATORS=(HOST=127.0.0.1:PORT=42582,HOST=127.0.0.1:PORT=42583)
```

## DSN Configuration on Windows

ODBC data source manager can add or set up DSN on Windows.

**Figure 3** Creating new data source

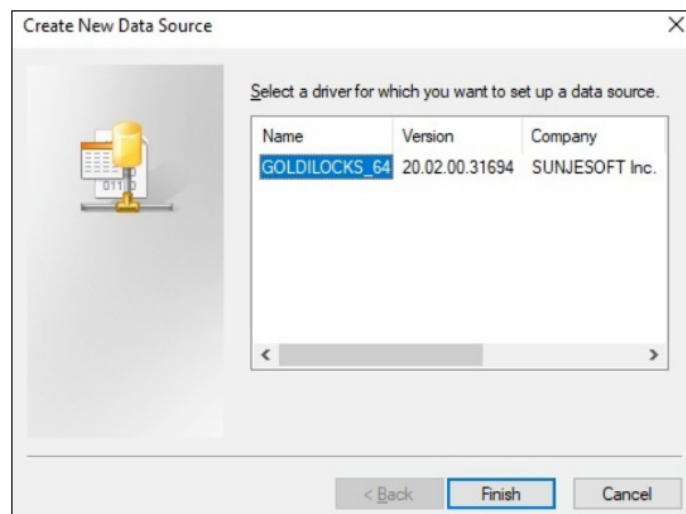

Figure 4 Configuring ODBC driver

The screenshot shows the 'GOLDILOCKS Driver Configuration' dialog box with the following settings:

- Connection:** DSN: GOLDILOCKS, HOST: 192.168.0.10, PORT: 22581, UID: TEST
- CS Mode:** Default (selected), Dedicated, Shared
- Failover:** Connection Retry: Count: 0, Delay: 0; Type: Connection (selected), Session; Granularity: Non-atomic (selected), Atomic
- AlternateServers:** (Empty text box)
- Global Connection:** Global Connection (checked), Global Session (unchecked); Group Policy: 0, Path: ; Member Policy: 0, Path:
- Locator:** HOST: 192.168.0.11, PORT: 42581, TIMEOUT: 3, FILE: ; AlternateLocators: .168.0.12:PORT=42581,HOST=192.168.0.13:PORT=42581
- Format:** DATE: SYYYY-MM-DD HH24:MI:SS; TIME: HH24:MI:SS.FF6; TIME WITH TIME ZONE: HH24:MI:SS.FF6 TZH:TZM; TIMESTAMP: SYYYY-MM-DD HH24:MI:SS.FF6; TIMESTAMP WITH TIME ZONE: SYYYY-MM-DD HH24:MI:SS.FF6 TZH:TZM
- Character Length Unit:** Octets (selected), Characters

The following table describes keywords for DSN configuration.

**Table 31-5** Keywords for DSN configuration

Keyword	Description
DSN	It is a data source name.
HOST	It is a host IP address or a host name.
PORT	It is a connection port number.
UID	It is a user ID.
CS_MODE	It sets whether to connect as dedicated mode or shared mode. If it is not set, the default mode is determined depending on the configuration (DEFAULT_CS_MODE) of the listener.
ALTERNATE_SERVERS	It is a server list which attempts to connect when the failover occurs. Each servers is separated by a comma (,). To disable the failover feature, set ALTERNATE_SERVERS as a white space.
CONNECTION_RETRY_COUNT	It is the number of times which the driver attempts to connect to the server when the connection fails.
CONNECTION_RETRY_DELAY	It is the server connection retry interval (in seconds) when the connection fails.
FAILOVER_TYPE	<ul style="list-style-type: none"> <li>• CONNECTION: When the connection fails, it is connected to ALTERNATE_SERVERS.</li> <li>• SESSION: When the connection fails or the connection is disconnected during operating the statement, it is connected to ALTERNATE_SERVERS and the statement is restored. The statement is executed after the failover if the connection is disconnected when a transaction is not in progress.</li> </ul>
FAILOVER_GRANULARITY	<ul style="list-style-type: none"> <li>• Non-atomic: The failover proceeds even when an error occurs.</li> <li>• Atomic: The failover fails when an error occurs.</li> </ul>
DATE_FORMAT	It is a DATE type string.
TIME_FORMAT	It is a TIME type string.
TIME_WITH_TIME_ZONE_FORMAT	It is a TIME WITH TIME ZONE type string.
TIMESTAMP_FORMAT	It is a TIMESTAMP type string.
TIMESTAMP_WITH_TIME_ZONE_FORMAT	It is a TIMESTAMP WITH TIME ZONE type string.
CHAR_LENGTH_UNITS	It is the unit of ColumnSize when ParameterType in SQLBindParameter() is SQL_CHAR, SQL_VARCHAR. <ul style="list-style-type: none"> <li>• BYTE, OCTETS: Byte unit</li> <li>• CHAR, CHARACTERS: Character unit</li> </ul>
LOCALITY_AWARE_TRANSACTION	It sets whether to use GLOBAL CONNECTION. <ul style="list-style-type: none"> <li>• It does not use GLOBAL CONNECTION.</li> <li>• It uses GLOBAL CONNECTION.</li> </ul>
USE_GLOBAL_SESSION	It sets whether to use GLOBAL SESSION. <ul style="list-style-type: none"> <li>• It does not use GLOBAL SESSION.</li> <li>• It uses GLOBAL SESSION.</li> </ul>
	If an available group does not exist or two or more groups can be selected when using GLOBAL CONNECTION, it sets how to select a group.



Keyword	Description
LOCALITY_GROUP_POLICY	<ul style="list-style-type: none"> <li>0: It arbitrarily selects a group.</li> <li>1: It sequentially selects groups existing in LOCALITY_GROUP_PATH settings. If all groups in LOCALITY_GROUP_PATH are not available, then it arbitrarily selects a group.</li> <li>2: It sequentially selects groups. It selects a group in a sequence of connected to the driver everytime.</li> </ul>
LOCALITY_GROUP_PATH	It specifies a list of selected groups if more than one group can be selected when using GLOBAL CONNECTION. Each group is separated with a comma (,). e.g. G1,G2,G3
LOCALITY_MEMBER_POLICY	It determines how to select a member within a selected group when using GLOBAL CONNECTION. <ul style="list-style-type: none"> <li>0: DML : MASTER / SELECT : MASTER</li> <li>1: DML : ANY / SELECT : ANY</li> <li>2: DML : MASTER / SELECT : ANY</li> <li>3: DML : MASTER / SELECT : SLAVE</li> <li>4: It sequentially selects members in LOCALITY_MEMBER_PATH settings. If all members in LOCALITY_MEMBER_PATH are not available, then it arbitrarily selects MASTER in the selected group.</li> </ul>
LOCALITY_MEMBER_PATH	It specifies a list of members to be used within a selected group when using GLOBAL CONNECTION. Each member is separated with a comma (,). e.g. G1N1,G2N1,G3N1,G1N2,G2N2,G3N2
LOCATOR_HOST	glocator ip address
LOCATOR_PORT	glocator port number
LOCATOR_CONNECTION_TIMEOUT	Connection timeout with glocator (second)
ALTERNATE_LOCATORS	If glocator does not respond, then it gets the connection information by using ALTERNATE_LOCATORS.
TRACE	It sets whether to use trace in ODBC API. <ul style="list-style-type: none"> <li>0: It does not use the trace.</li> <li>1: It uses the trace.</li> </ul>
TRACEFILE	It is the name of the trace file. When the relative path is input, then it is based on the directory in which the program currently runs. The default value is 'odbc_trace.log'.
DOT_NET_FOR_ODBC	It is whether to use ODBC for .NET Framework. <ul style="list-style-type: none"> <li>0: It does not change its usage.</li> <li>1: It replaces SQL_DESC_BASE_COLUMN_NAME, SQL_DESC_NAME properties, in SQLGetDescField() and SQLColAttribute() with SQL_DESC_LABEL property.</li> </ul>

## 31.3 GLOBAL CONNECTION

GLOBAL CONNECTION of which an application selects and performs an appropriate node for a query processing in cluster environment is supported.

### Settings

GLOBAL CONNECTION is available only when PROTOCOL is TCP. In this case, LOCALITY\_AWARE\_TRANSACTION property value should be set together with LOCATOR file or LOCATOR server. USE\_GLOBAL\_SESSION property value should be set to 1 to use the global session feature.

- .odbc.ini of when using DSN

```
[GOLDILOCKS]
PROTOCOL = TCP
HOST = 192.168.0.1
PORT = 22581
UID = TEST
PWD = test
LOCALITY_AWARE_TRANSACTION = 1
LOCATOR_DSN = LOCATOR
[LOCATOR]
FILE = /home/goldilocks/.location.ini
```

- Using connection string

```
SQLDriverConnect( dbc,
                  NULL,
                  (SQLCHAR*)"PROTOCOL=TCP;HOST=192.168.0.1;PORT=22581;UID=TEST;PWD=test;LOCALITY_AWARE_TRANSACTION=1;LOCATOR_HOST=192.168.0.2;LOCATOR_PORT=42581",
                  SQL_NTS,
                  NULL,
                  0,
                  NULL,
                  SQL_DRIVER_NOPROMPT );
```

## Processing GLOBAL CONNECTION

Figure 5 Basic steps of applying GLOBAL CONNECTION

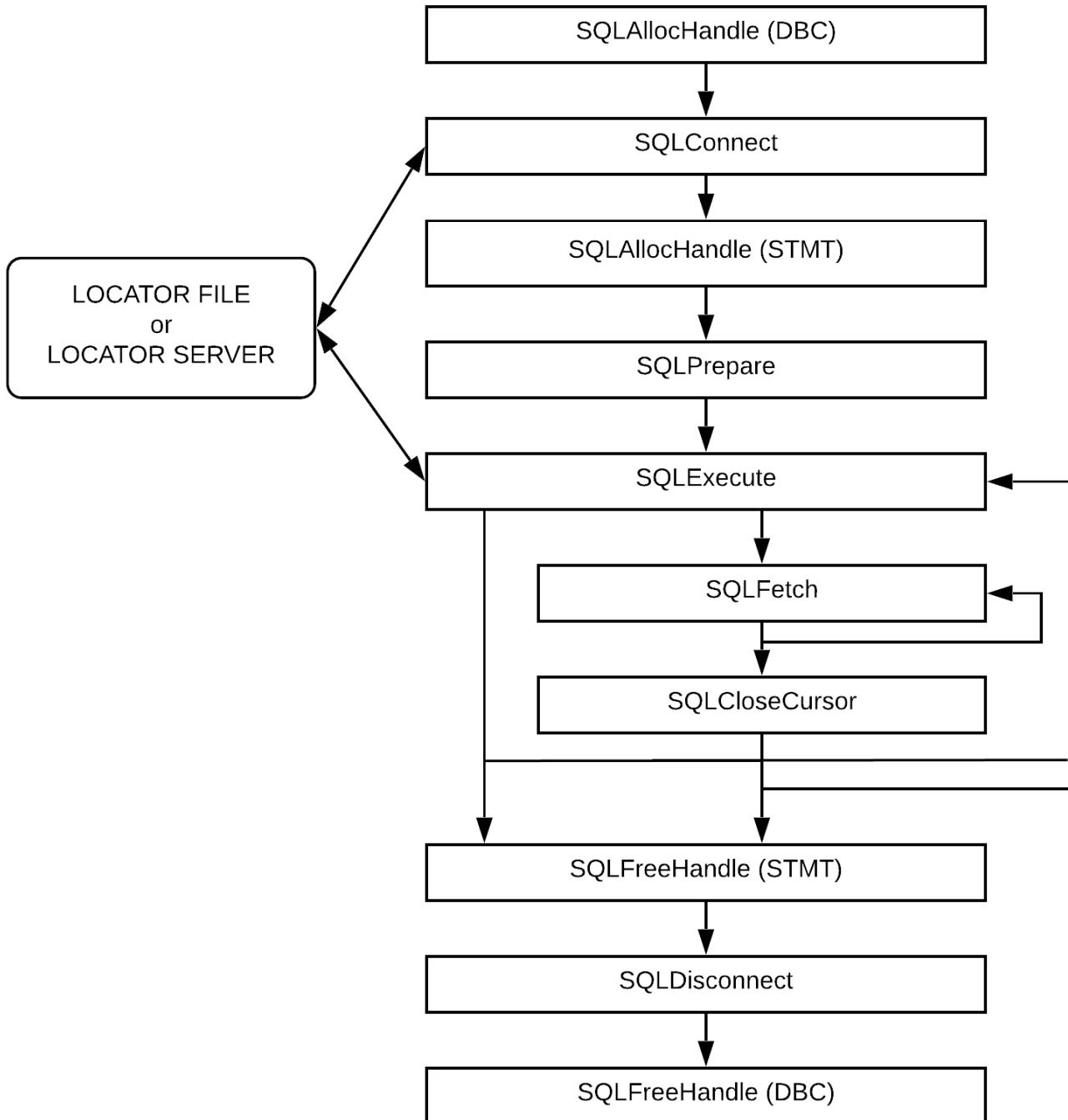

1. SQLAllocHandle (DBC)  
It allocates a connection handle.
2. SQLConnect  
It connects to a server which was given server information from a user, and obtains the information about the cluster system. Then builds the cluster system information through LOCATOR file or LOCATOR SERVER.

OR server, and connects to all nodes of cluster system.

3. SQLAllocHandle( STMT )

It allocates a statement to each of all connected nodes.

4. SQLPrepare

It prepares to execute SQL in all connected nodes.

5. SQLExecute

If the information about the cluster system is not built, an application builds the information about the cluster system through LOCATOR file or LOCATOR server, then connects to all nodes in the cluster system.

When connecting to a new node by adding a node to cluster, all statements of other nodes are equally created in that node, and prepares to execute SQL.

If the information about a sharding key has already built, an application selects an appropriate node and performs a query by using the sharding key information.

If the information about a sharding key is not built, an application builds the sharding key information of the SQL from an arbitrary server, then selects a node and performs a query.

If an error occurs on the selected node, an appropriate node is selected again, then performs a query.

If the information about a sharding key is altered after SQLExecute, then it deletes the built information about a sharding key

If the information about the cluster system is altered such as adding or deleting a cluster node after SQLExecute, then it deletes the built cluster system information.

6. SQLFetch

It brings data from the node on which SQL was executed.

7. SQLCloseCursor

It closes a cursor from the node on which SQL was executed.

8. SQLFreeHandle( STMT )

It releases a statement from all connected nodes.

9. SQLDisconnect

It releases connections with all nodes.

10. SQLFreeHandle( DBC )

It releases a connection handle.

## Handling GLOBAL CONNECTION Exception

When using GLOBAL CONNECTION, if an error occurs on the selected node during the operation, then it is operated as follows according to the transaction occurrence and SELECT progress.

- When a transaction did not occur

If an error occurs on the selected node when a transaction did not occur, then it selects another node within ODBC and executes the query. Though an error occurred on the selected node, the query was normally executed on another node, so it does not transfer an error to a user.

- When a transaction occurred or SELECT is in progress

If an error occurs on the selected node when a transaction occurred or SQLFetch() is in progress, then ODBC can not proceed the current operation any more so it transfers 19068(Retry the transactional operations) error. If 19068 error occurs, then a user should perform the transaction or SELECT again.

```

if( !SQL_SUCCEEDED(SQLPrepare( sStmt,
                               (SQLCHAR*)"INSERT INTO T1 VALUES ( ? )",
                               SQL_NTS )) )
{
    goto stmt_error;
}
trans_retry:
if( !SQL_SUCCEEDED(SQLExecute( sStmt )) )
{
    SQLGetDiagRec( SQL_HANDLE_STMT,
                  sStmt,
                  1,
                  sSQLState,
                  &sNativeError,
                  sMessageText,
                  sizeof(sMessageText),
                  &sTextLength );
    if( sNativeError == 19068 )
    {
        goto trans_retry;
    }
    goto stmt_error;
}

```

```
if( !SQL_SUCCEEDED(SQLPrepare( sStmt,
                               (SQLCHAR*)"SELECT * FROM T1 WHERE C1 = ?",
                               SQL_NTS )) )
{
    goto stmt_error;
}
trans_begin:
sReturn = SQLExecute( sStmt );
if( sReturn == SQL_ERROR )
{
    SQLGetDiagRec( SQL_HANDLE_STMT,
                  sStmt,
                  1,
                  sSQLState,
                  &sNativeError,
                  sMessageText,
                  sizeof(sMessageText),
                  &TextLength );
    if( sNativeError == 19068 )
    {
        goto trans_retry;
    }

    goto stmt_error;
}
while( 1 )
{
    sReturn = SQLFetch( sStmt );
    if( sReturn == SQL_NO_DATA )
    {
        SQLCloseCursor( sStmt );
        break;
    }
    else if( sReturn == SQL_ERROR )
    {
        SQLGetDiagRec( SQL_HANDLE_STMT,
                      sStmt,
                      1,
                      sSQLState,
                      &sNativeError,
                      sMessageText,
```

```

        sizeof(sMessageText),
        &sTextLength );
    if( sNativeError == 19068 )
    {
        goto trans_retry;
    }

    goto stmt_error;
}
...
}

```

- When committing or rolling back a transaction

If an error occurs on the selected node when committing a transaction, then ODBC checks whether the transaction has been committed before the error occurred through another node. Though an error occurred on the selected node, if the transaction was normally committed, then it does not transfer an error. Also, if an error occurred on the selected node when a transaction has not been committed, then it transfers 19068(Retry the transactional operations) error. If 19068 error occurs, then a user should perform the transaction again.

If an error occurs on the selected node when rolling back a transaction, then ODBC does not transfer an error. It is because the transaction already has been rolled back due to the node error.

```

if( !SQL_SUCCEEDED(SQLSetConnectAttr( sDbc,
                                     SQL_AUTOCOMMIT,
                                     (SQLPOINTER)SQL_AUTOCOMMIT_OFF,
                                     0 ) ))
{
    goto dbc_error;
}
if( !SQL_SUCCEEDED(SQLPrepare( sStmt,
                              (SQLCHAR*)"INSERT INTO T1 VALUES ( ? )",
                              SQL_NTS )) )
{
    goto stmt_error;
}
trans_retry:
if( !SQL_SUCCEEDED(SQLExecute( sStmt )) )
{
    SQLGetDiagRec( SQL_HANDLE_STMT,
                  sStmt,

```

```

        1,
        sSQLState,
        &sNativeError,
        sMessageText,
        sizeof(sMessageText),
        &sTextLength );
if( sNativeError == 19068 )
{
    goto trans_retry;
}

goto stmt_error;
}
if( !SQL_SUCCEEDED(SQLEndTran( SQL_HANDLE_DBC,
                               sDbc,
                               SQL_COMMIT)) )
{
    SQLGetDiagRec( SQL_HANDLE_DBC,
                  sDbc,
                  1,
                  sSQLState,
                  &sNativeError,
                  sMessageText,
                  sizeof(sMessageText),
                  &sTextLength );
if( sNativeError == 19068 )
{
    goto trans_retry;
}

goto stmt_error;
}

```

## Constraints of GLOBAL CONNECTION

- Use SQLPrepare() and SQLExecute() to select a node appropriate for the query.

Use SQLPrepare() and SQLExecute() to select a node appropriate for the query by using GLOBAL CONNECTION. SQLExecDirect() does not have an information required to select a node appropriate for the query, so the node is selected according to LOCALITY\_GROUP\_POLICY and LOCALITY\_MEMBER\_POLICY property.



y.

- Use `SQLEndTran()` to commit or rollback a transaction.

If committing or rolling back with SQL statement when using GLOBAL CONNECTION, then the status change of the transaction is not detected. It is mandatory to use `SQLEndTran()` to commit or rollback the transaction.

- Global session feature does not support Data Definition Language (DDL) among SQL statements.

## 31.4 Catalog Function

All databases have schemas of how to store the data in the database. For example, a simple sales order database will have the schemas shown in the following figure, and the ID columns are used to connect the tables.

**Figure 6** Schema of sales orders

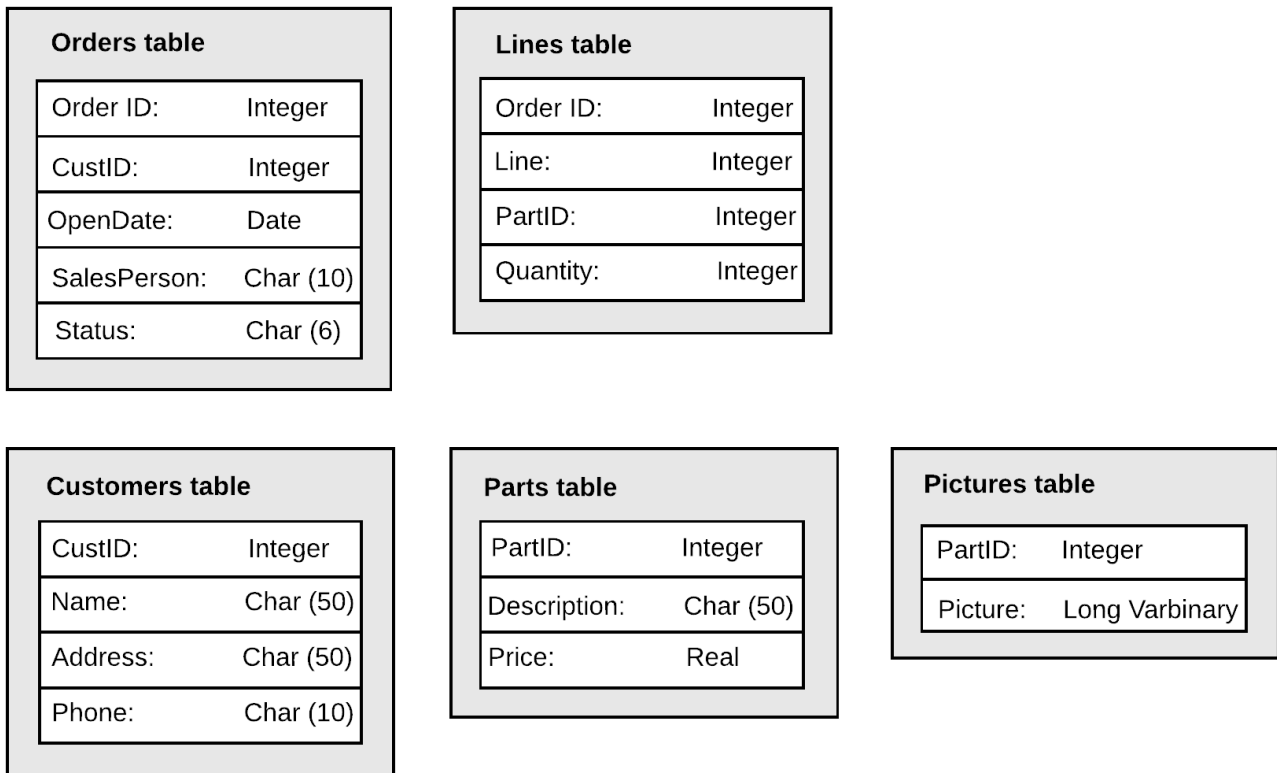

The schema is stored in the set of system tables which is called as a database catalog along with other information such as privileges. This is also known as a data dictionary.

Applications can find this schema by calling the catalog functions. Catalog functions return the information to the result set, and typically they are implemented by SELECT statements for the tables in the catalog.

### Using Catalog Data

Applications use catalog data in various ways. The followings are some common usages.

## Configuring SQL statements at the time of execution

The vertical applications such as the order input application include the hard-coded SQL statements. The tables and columns used by the application were previously fixed, and the application access these tables. For example, the ordering application typically has one parameterized statement to add a new order to the system.

A general application such as a spreadsheet program using ODBC for collecting the data sometimes configures the SQL statement based on the input from a user at the time of execution. This application may request a user for the format to use tables and columns. However, if the list of tables or columns selected by a user is shown to the application, it will be easier to the user. The application will call catalog functions such as `SQLTables` and `SQLColumns` to configure these lists.

## Configuring SQL statements during the development

The application development environments allow the developers to create database queries during developing the program. And then the queries are hard-coded and embedded into the application.

These environments can also create a list of what were selected by the developer by using the `SQLTables` and `SQLColumns`. The environments find out and display the relationships among the tables automatically selected by using `SQLPrimaryKeys` and `SQLForeignKeys`. Then they find out and emphasize the index fields by using `SQLStatistics`, so the developers can create queries effectively.

## Configuring a Cursor

The application, driver, middleware which provides a scroll cursor, find out column(s) which is the only column of identifying a row by using `SQLSpecialColumns`. The program can configure a keyset including the values of these columns for the collected rows. The application will use these values to collect the latest data for the rows by scrolling backwards.

## Catalog Function on ODBC

ODBC includes the following catalog functions.

Function	Description
<code>SQLTables</code>	It returns a list of catalogs, schemas, tables or table types in the data source.
<code>SQLColumns</code>	It returns a list of columns in one or more tables.
<code>SQLStatistics</code>	It returns a list of statistics for a single table. It also returns a list of indexes linked to the table.
<code>SQLSpecialColumns</code>	It returns a list of columns which is the only column of identifying a row in a table. Also,

Function	Description
	it returns a list of columns in the table, and they are automatically updated.
SQLPrimaryKeys	It returns a list of columns which configure the primary key of a table.
SQLForeignKeys	It returns a list of foreign keys in a table or it returns a list of foreign keys in another table referring that table.
SQLTablePrivileges	It returns a list of privileges associated with one or more tables.
SQLColumnPrivileges	It returns a list of privileges associated with one or more columns in a table.
SQLProcedures	It is not supported by the driver.
SQLProcedureColumns	It is not supported by the driver.
SQLGetTypeInfo	It returns a list of SQL data types supported by the data source. These data types are generally used in CREATE TABLE, ALTER TABLE statements.

## Data Returning of Catalog Function

Each catalog function returns the data as a result set. The result set is not different from any other result set. It is usually hard-coded into the driver, or it is created by the predefined statement such as the parameterized SELECT statement stored in the procedure of data source.

The result set for each catalog function is described in *For More Information* paragraph of each function in this user manual. The result set can include the columns specified in the driver after the column selected last besides the listed columns. These columns are described in a user manual for the driver.

The applications bind the columns specified in the driver based on the end of result set. They calculate the number of columns specified in the driver as the number of last columns which are smaller than the number of columns after the required column. This saves the trouble of changing the application when a new column is added in future version or ODBC driver. To operate this schema, drivers should add the columns specified in the new driver before the columns specified in the old driver to prevent changing the row number based on the end of result set.

Even when they include special characters, they do not quote the identifiers returned in the result set. For example, if the Accounts Payable table's identifier quote character which is specified in the driver and returned by SQL GetInfo is a double quotes ("), and the Accounts Payable table has a Customer Name column, then TABLE\_NAME column value in the rows which is returned by SQLColumns is Accounts Payable, but it is not "Accounts Payable", and COLUMN\_NAME column value is Customer Name, but it is not "Customer Name".

The application collects the names of customers from the Accounts Payable table as follows.

```
SELECT "Customer Name" FROM "Accounts Payable"
```

Catalog functions are based on SQL-like model in connection based on the user name and password, and their data is returned only to the users with the proper privilege. The file password protection which is in

appropriate to this model is defined by the drivers.

Most result set returned by the catalog functions can not be updated, and the application should not expect to change the database schema by updating the data in the result set.

## Arguments of Catalog Function

### Pattern Value Argument

Some arguments in catalog function accept the search pattern, like as `TableName` argument in `SQLTables`. The arguments accept the search pattern if `SQL_ATTR_METADATA_ID` attribute is set to `SQL_FALSE`. The arguments do not accept the search pattern if `SQL_ATTR_METADATA_ID` attribute is set to `SQL_TRUE`.

Search pattern letters have the following features.

- An underscore (`_`) represents any single character.
- Percent sign (`%`) represents zero or more characters.
- An escape character is specified in the driver and it is used to include the percent sign, underscore, escape character as literals. If an escape character is prior to a non-special character, it does not have any special meaning. But if an escape character is prior to a special character, it is a special character. For example, `"\a"` is treated as two characters consisting of `"\"` and `"a"`, but `"\%"` refers to `"%"`.

An escape character is returned by using `SQL_SEARCH_PATTERN_ESCAPE` option in `SQLGetInfo`. To include that character as a literal in an argument which accepts search patterns, it should be prior to any underscore, percent sign, or escape character.

The following table describes how to use search patterns.

Search pattern	Description
<code>%A%</code>	It is all identifiers which contain A.
<code>ABC_</code>	It is all four letter characters which start with ABC.
<code>ABC\</code>	It assumes the escape character a backslash ( <code>\</code> ), and the identifier is <code>ABC_</code> .
<code>\%\</code>	It assumes the escape character a backslash ( <code>\</code> ), and the identifier which start with a backslash ( <code>\</code> )



Be cautious when using a escape character in an argument which accepts a search pattern. This is particularly TRUE for the underscore (`_`) which is generally used as the identifier.

It is a common mistake in the application that the value returned by one catalog function is passed to the search pattern argument of another catalog function.

For example, if the application gets `MY_TABLE` table from the result set of `SQLTables` and passes it to `SQLColumns` to retrieve the column list of `MY_TABLE`, then, the application will get the columns of all tables such as `MY_TABLE`, `MY1TABLE`, `MY2TABLE` instead of getting the columns

of MY\_TABLE because they match the search pattern MY\_TABLE.



ODBC 2.x driver does not support the search pattern for CatalogName argument of SQL tables. ODBC 3.x driver supports the search pattern within the argument if the environment attribute SQL\_ATTR\_ODBC\_VERSION is set to SQL\_OV\_ODBC3. The argument does not accept the search pattern if this property is set to SQL\_OV\_ODBC2.

Passing a NULL pointer to the search pattern argument does not force the argument to search. NULL pointer and the search patterns % (any character) are equivalent. However, a zero-length search pattern is matched with an empty string ("").

## 31.5 ODBC API References

### SQLAllocConnect

#### Conformance

Introduced version: ODBC 1.0

#### Overview

SQLAllocConnect function is replaced by SQLAllocHandle function in ODBC 3.x.  
For more information, refer to [SQLAllocHandle](#).

#### Syntax

```
SQLRETURN SQLAllocConnect(  
    SQLHENV EnvironmentHandle,  
    SQLHDBC * ConnectionHandlePtr);
```

#### Arguments

##### EnvironmentHandle

[Input] It is the environment handle.

##### ConnectionHandlePtr

[Output] It is the pointer of the connection handle to be newly allocated.

# SQLAllocEnv

## Conformance

Introduced version: ODBC 1.0

## Overview

SQLAllocEnv function is replaced by SQLAllocHandle function in ODBC 3.x.  
For more information, refer to [SQLAllocHandle](#).

## Syntax

```
SQLRETURN SQLAllocEnv(  
    SQLHENV * EnvironmentHandlePtr);
```

## Arguments

### EnvironmentHandlePtr

[Output] It is the pointer of the environment handle to be newly allocated.



# SQLAllocHandle

## Conformance

Introduced version: ODBC 3.0

Standards compliance: ISO 92

## Overview

SQLAllocHandle allocates the environment handle, the connection handle, or the statement handle.

## Syntax

```
SQLRETURN SQLAllocHandle(  
    SQLSMALLINT   HandleType,  
    SQLHANDLE     InputHandle,  
    SQLHANDLE *   OutputHandlePtr);
```

## Arguments

### HandleType

[Input] It is the handle type allocated by SQLAllocHandle and it should be one of SQL\_HANDLE\_DBC, SQL\_HANDLE\_ENV, SQL\_HANDLE\_STMT.

### InputHandle

[Input] If HandleType is SQL\_HANDLE\_ENV, it is SQL\_NULL\_HANDLE.

If HandleType is SQL\_HANDLE\_DBC, it should be an environment handle.

If it is SQL\_HANDLE\_STMT, it should be a connection handle.

### OutputHandlePtr

[Output] It is the newly allocated handle pointer.

## Returns

SQL\_SUCCESS, SQL\_SUCCESS\_WITH\_INFO, SQL\_INVALID\_HANDLE, SQL\_ERROR

## Diagnosis

SQLSTATE	Error	Description
08003	Connection not open	It is not connected and HandleType is one of SQL_HANDLE_STMT and SQL_HANDLE_DESC.
HY000	General error	It is an error without any specific SQLSTATE.
HY001	Memory allocation error	It is a memory allocation error.
HY009	Invalid use of null pointer	OutputHandlePtr argument is a null pointer.
HY010	Function sequence error	HandleType argument is SQL_HANDLE_DBC, and SQLSetEnvAttr is not called for setting SQL_ODBC_VERSION environment attribute.
HY014	Limit on the number of handles exceeded	It limits the number of allocated handles.
HY092	Invalid attribute/option identifier	HandleType argument is not one of SQL_HANDLE_ENV, SQL_HANDLE_DBC, SQL_HANDLE_STMT, SQL_HANDLE_DESC.
IM001	Driver does not support this function	HandleType argument is SQL_HANDLE_DESC.

## Description

SQLAllocHandle is used to allocate the handle for environment, connection, statement, descriptor. When using SQLAllocHandle with \*OutputHandlePtr, the driver will overwrite the information on the corresponding handle. The driver manager can not verify whether the handle in \*OutputHandlePtr is already used, and it can not know the previously overwritten information.

## Allocating Environment Handle

The environment handle provides the global information such as whether the connection handle is valid or active.

For requesting the environment handle, the application calls SQLAllocHandle whose HandleType is SQL\_HANDLE\_ENV and whose InputHandle is SQL\_NULL\_HANDLE. The driver allocates memory for the environment information, and passes an allocated handle to \*OutputHandle argument. The application passes the value of \*OutputHandle to the call requiring the environment handle argument.

After allocating the environment handle, the application should set the attribute of SQL\_ATTR\_ODBC\_VERSION by calling SQLSetEnvAttr. If the attribute is not set when calling SQLAllocHandle for allocating the connection handle, SQLSTATE HY010 (Function sequence error) is returned.

## Allocating Connection Handle

The connection handle provides the information such as whether the statement is valid, the descriptor handle is connected, or the transaction currently is opened.

For requesting the connection handle, the application calls `SQLAllocHandle` whose `HandleType` is `SQL_HANDLE_DBC`. `InputHandler` argument is set to the environment handle returned by calling `SQLAllocHandle`. The driver allocates memory for the connection information, and passes an allocated handle to `*OutputHandle` argument. The application passes the value of `*OutputHandle` to the call requiring a connection handle argument.

If the environment attribute of `SQL_ATTR_ODBC_VERSION` is not set before the calling `SQLAllocHandle` which allocates a connection handle, `SQLSTATE HY010`(Function sequence error) is returned.

## Allocating Statement Handle

The statement handle provides the information such as the error message, the cursor name and the SQL statement processing status.

For requesting the statement handle, the application connects to the data source and then calls `SQLAllocHandle` before sending the SQL statement. In this call, `HandleType` should be set to `SQL_HANDLE_STMT` and `InputHandler` should be set to the connection handle returned by calling `SQLAllocHandle`. The driver allocates memory for the statement information, and passes the allocated handle to `*OutputHandle` argument. The application passes the value of `*OutputHandle` to the call requiring a statement handle argument.

If the statement handle is allocated, the driver automatically allocates four descriptor sets, and these descriptor handles are allocated to the statement attribute of `SQL_ATTR_APP_ROW_DESC`, `SQL_ATTR_APP_PARAM_DESC`, `SQL_ATTR_IMP_ROW_DESC` and `SQL_ATTR_IMP_PARAM_DESC`. This is called as implicit descriptor allocation.

# SQLAllocStmt

## Conformance

Introduced version: ODBC 1.0

## Overview

SQLAllocStmt function is replaced by SQLAllocHandle function in ODBC 3.x.  
For more information, refer to [SQLAllocHandle](#).

## Syntax

```
SQLRETURN SQLAllocStmt(  
    SQLHDBC    ConnectionHandle,  
    SQLHSTMT * StatementHandlePtr);
```

## Arguments

### ConnectionHandle

[Input] It is the connection handle.

### StatementHandlePtr

[Output] It is the pointer of the statement handle to be newly allocated.

# SQLBindCol

## Conformance

Introduced version: ODBC 1.0

Standards compliance: ISO 92

## Overview

SQLBindCol binds the application data buffer to the columns in the result set.

## Syntax

```
SQLRETURN SQLBindCol(
    SQLHSTMT      StatementHandle,
    SQLUSMALLINT  ColumnNumber,
    SQLSMALLINT   TargetType,
    SQLPOINTER    TargetValuePtr,
    SQLLEN        BufferLength,
    SQLLEN *      StrLen_or_Ind);
```

## Arguments

### StatementHandle

[Input] It is the statement handle

### ColumnNumber

[Input] It is the column number in the result set to be bound. The number is in ascending order starting from 1.

### TargetType

[Input] It is the identifier of C data type of \*TargetValuePtr buffer. When retrieving data using SQL Fetch, SQLFetchScroll, SQLSetPos, the driver converts the data into this type.

If TargetType is the interval data type, the default value is the interval leading precision (2), interval seconds precision (6), and it is set in each field of SQL\_DESC\_DATETIME\_INTERVAL\_PRECISION and SQL\_DESC\_PRECISION of ARD. If TargetType argument is SQL\_C\_NUMERIC, the default value is precision (38), scale (0), and it is set in each field of SQL\_DESC\_PRECISION and SQL\_DESC\_SCALE of ARD. If the default precision and scale are not appropriate, the application must explicitly set the descriptor field by calling SQLSetDescField or SQLSetDescRec.

**TargetValuePtr**

[Delayed Input/Output] It is the data buffer pointer to bind to the column. SQLFetch and SQLFetchScroll return data to this buffer.

If TargetValuePtr is the null pointer, the driver releases the data buffer binding for the column. The application may release the binding of all the columns by calling SQLFreeStmt as SQL\_BIND option. The application can release the data buffer binding for the column by setting TargetValuePtr argument as a null pointer and calling SQLBindCol. But if StrLen\_or\_IndPtr is valid, the length/indicator buffer for the column is still bound.

**BufferLength**

[Input] It is the length of \*TargetValuePtr buffer in bytes.

The driver uses BufferLength in order to avoid writing beyond the end of \*TargetValuePtr buffer when returning the variable-length data such as text or binary data. It should be noted that the driver take into account the null terminator when returning the character data in \*TargetValuePtr. So, \*TargetValuePtr should include the space for a null terminator, otherwise the driver may drop the data. The driver assumes that the buffer is large enough to store data and it ignores BufferLength when returning a fixed-length data structure such as an integer or date. It is important that the application allocates the large buffer for the fixed-length data, otherwise the driver can write beyond the end of the buffer.

**StrLen\_or\_IndPtr**

[Delayed Input/Output] It is the pointer to the length/indicator buffer to be bound to the column. SQLFetch and SQLFetchScroll return the value to this buffer.

SQLFetch and SQLFetchScroll return the length of data for the length/indicator buffer, SQL\_NO\_TOTAL and SQL\_NULL\_DATA. If there are two separate buffers for the length and indicator, the length buffer may return all values, and the indicator buffer may only return only SQL\_NULL\_DATA. If StrLen\_or\_IndPtr is the null pointer, the value of length/indicator is not used and an error occurs when getting the null data.

**Returns**

SQL\_SUCCESS, SQL\_SUCCESS\_WITH\_INFO, SQL\_INVALID\_HANDLE, SQL\_ERROR

**Diagnosis**

SQLSTATE	Error	Description
07006	Restricted data type attribute violation	ColumnNumber argument is 0, and TargetType argument is neither SQL_C_BOOKMARK nor is SQL_C_VARBOOKMARK.
HY000	General error	It is an error without any specific SQLSTATE.
HY001	Memory allocation error	It is a memory allocation error.
HY003	Invalid application buffer type	The value of TargetType argument is the invalid data type.

SQLSTATE	Error	Description
HY010	Function sequence error	After calling SQLExecute and SQLExecDirect, then SQL_NEED_DATA is returned, and the function is called before sending all data-at-execution variables.
HY090	Invalid string or buffer length	The value of BufferLength argument is smaller than 0.
HYC00	Optional feature not implemented	The driver does not support the SQL data type of the column and the value of TargetType argument and the conversion. The value of ColumnNumber argument is 0, and the driver does not support bookmarks.

## Description

SQLBindCol is used to bind columns in the result set to the data buffer and the length/indicator buffers in the application. The application calls SQLFetch and SQLFetchScroll to retrieve the data, and the driver returns the bound column data to the specified buffer.

The application does not bind the column, and the data is retrieved by calling SQLGetData.

## Binding Column

The application calls SQLBindCol to bind the column, and passes the column number, the type, the address, the data buffer length and the address of length/indicator buffer.

Though the application binds the buffer by calling SQLBindCol, but the driver accesses them when calling SQLFetch and SQLFetchScroll, so these buffers are delayed when it is used. Therefore, the application should make the pointer set in SQLBindCol to be valid until the data is returned. If the application calls after making the pointer invalid, like when releasing the buffer, the result is not correct.

The binding remains until when it is replaced by a new binding, the column binding is released, or the statement is released.

## Releasing Bound Column

To release only one bound column, set the column number to be released as ColumnNumber and call SQLBindCol by setting TargetValue to the null pointer in the application. If ColumnNumber is the column number whose binding is released, SQLBindCol continues returning SQL\_SUCCESS.

To release all bound columns, call SQLFreeStmt by setting option to SQL\_UNBIND in the application. Or, set SQL\_DESC\_COUNT field of ARD to 0 to release all bound columns.

## Rebinding Column

The application can perform one of two operations to change the binding.

- A new binding is specified for an existing bound column by calling `SQLBindCol`.
- The offset is added to the specified buffer address by calling `SQLBindCol`. For more information, refer to **Binding Offsets**.

## Binding Offsets

Binding offset is the value added to the address before the data and length/indicator buffers (specified in `TargetValuePtr` and `StrLen_or_IndPtr`) are dereferenced.

Using binding offset generally has the same effect as rebinding the column by calling `SQLBindCol`. However, the new address of the data and length/indicator buffer are specified when newly calling `SQLBindCol`, but binding offset does not change the address, instead it adds only the offsets to the address. The application can specify a new offset anytime, and the offset is always added to the originally bound address. Especially, if the offset is set to 0 or the statement attribute is set to NULL pointer, the driver uses the originally bound address.

The sum of the originally bound address and the offset should be a valid address, but the offset address to be added does not have to be valid.

## Binding Array

If the row set size (the value of `SQL_ATTR_ROW_ARRAY_SIZE` statement attribute) is bigger than 1, the application binds a buffer array instead of a single buffer.

The application can bind an array in two ways as follows.

- Bind an array to each column. Each data structure (array) contains data for a single column, so it is called as **Column-wise Binding**.
- Define a structure containing the entire row data and bind the array of these structures. Each data structure contains data for a single row, so it is called as **Row-wise Binding**.

Each buffer array should have at least as many elements as the row set size.

## Column-wise Binding

The application binds the separate data and length/indicator array to each column in column-wise binding.

The application should set `SQL_ATTR_ROW_BIND_TYPE` statement attribute to `SQL_BIND_BY_COLUMN` (default value) to use the column-wise binding. Then, the application performs the following processes for the columns to be bound.



1. It allocates the data buffer array.
2. It allocates the array of length/indicator buffer.



If the application directly records to the descriptors when using the column-wise binding, the separate arrays can be used for length and indicator data.

3. It calls `SQLBindCol` together with the following arguments.
  - `TargetType` is the type of each element of the data buffer array.
  - `TargetValuePtr` is the address of the data buffer array.
  - `BufferLength` is the size of each element of the data buffer array. `BufferLength` is ignored when the data is fixed length data.
  - `StrLen_or_IndPtr` is the address of the length/indicator array.

## Row-wise Binding

The application defines a structure which contains the data and length/indicator buffer of each column to be bound in row-wise binding.

The application performs the following processes to use row-wise binding.

1. It defines a structure which contains a row (including both of data and the length/indicator buffer) and allocates an array of the structures.



If the application directly records to the descriptors when using the row-wise binding, the separate fields can be used for length and indicator data.

2. `SQL_ATTR_ROW_BIND_TYPE` statement attribute sets the size of structure including a data row or as the buffer instance size for the result columns to be bound. The length should include the space and structure of all bound columns and the padding of the buffer. It should guarantee to point to the starting position in the same column of the next line when the address of the bound column is increased by the specified length. ANSI C guarantees it by using the `sizeof` operator.
3. It calls `SQLBindCol` together with the following arguments for each column to be bound.
  - `TargetType` is the type of the data buffer member to be bound to the column.
  - `TargetValuePtr` is the address of the data buffer member in the first array element.
  - `BufferLength` is the size of the data buffer member.
  - `StrLen_or_IndPtr` the address of the length/indicator member to be bound.

## Buffer Address

The buffer address is an actual address of the data or the length/indicator buffer. The driver calculates the buffer address before writing to the buffer (such as the data collect). It is calculated by the following formula, which uses the address, binding offset, row number specified in TargetValuePtr and StrLen\_or\_IndicatorPtr.

$$\text{Bound Address} + \text{Binding Offset} + ((\text{Row Number} - 1) \times \text{Element Size})$$

The following table describes the definitions of the formula's variables.

**Table 31-6** Formula's variable

Variable	Description
Bound address	The address of data buffer is specified in TargetValuePtr argument of SQLBindCol. The address of length/indicator buffer is specified in StrLen_or_IndicatorPtr argument of SQLBindCol. If the binding address is 0, the data value is not returned, even though the calculated address is not 0.
Binding offset	If row-wise binding is used, this value is stored in the address specified with the SQL_ATTR_ROW_BIND_OFFSET_PTR statement attribute. If column-wise binding is used or the SQL_ATTR_ROW_BIND_OFFSET_PTR statement attribute is a NULL pointer, then the binding offset is 0.
Row number	It is 1-based number of the row in the row set. When fetching a single row, generally the row number is 1.
Element size	It is the element size of binding array.  If column-wise binding is used, it is sizeof (SQLLEN) for the length/indicator buffer. The element size of the data buffer of variable length data type is the value of BufferLength argument of SQLBindCol, and the element size of the data buffer of fixed length data type is the size of the data type.  If row-wise binding is used, the element size of both the data and the length/indicator buffer are the value of the SQL_ATTR_ROW_BIND_TYPE statement.

## Descriptors and SQLBindCol

This chapter describes how SQLBindCol interacts with descriptors.



Calling SQLBindCol for a single statement may affect other statements. It occurs when a resource related to the statement is explicitly allocated and it is related to other statements. The modifications for the descriptor affects all statements related to the descriptor because SQLBindCol modifies the descriptor. If it is not the required behavior, the application should release the relationship between the descriptor and other statements before calling SQLBindCol.

## Argument Mapping

Notionally, SQLBindCol performs the following processes in order.

1. It calls SQLGetStmtAttr to obtain ARD handle.
2. It calls SQLGetDescField to obtain the descriptor of SQL\_DESC\_COUNT field, and if the value in the ColumnNumber argument exceeds the value of SQL\_DESC\_COUNT, it calls SQLSetDescField to increase the value of SQL\_DESC\_COUNT to ColumnNumber.
3. It calls SQLSetDescField multiple times to assign values to the following fields of ARD.
  - It sets SQL\_DESC\_TYPE and SQL\_DESC\_CONCISE\_TYPE to the value of TargetType.
    - Except when TargetType is one of the concise identifiers of a datetime or interval subtype, it respectively sets SQL\_DESC\_TYPE to SQL\_DATETIME or SQL\_INTERVAL. It sets SQL\_DESC\_CONCISE\_TYPE to the concise identifier; and sets SQL\_DESC\_DATETIME\_INTERVAL\_CODE to the corresponding datetime or interval subcode.
  - It appropriately sets one or more of SQL\_DESC\_LENGTH, SQL\_DESC\_PRECISION, SQL\_DESC\_SCALE, and SQL\_DESC\_DATETIME\_INTERVAL\_PRECISION, for TargetType.
  - It sets the SQL\_DESC\_OCTET\_LENGTH field to the value of BufferLength.
  - It sets the SQL\_DESC\_DATA\_PTR field to the value of TargetValue.
  - It sets the SQL\_DESC\_INDICATOR\_PTR field to the value of StrLen\_or\_Ind.
  - It sets the SQL\_DESC\_OCTET\_LENGTH\_PTR field to the value of StrLen\_or\_Ind.

The variable referenced by StrLen\_or\_Ind argument is used for both indicator and length information. If the value of column when fetching is null, it stores SQL\_NULL\_DATA in this variable. Otherwise, it stores the data length in this variable.

Entering a null pointer, and the value of column when fetching is null, then the fetch fails because it cannot return SQL\_NULL\_DATA.

If SQLBindCol fails, the contents of the descriptor fields which will be set in ARD are not defined, and the value of SQL\_DESC\_COUNT field of ARD is not updated.

### Implicit Initialization of COUNT Field

SQLBindCol sets SQL\_DESC\_COUNT to the value of the ColumnNumber only when ColumnNumber increase the value of SQL\_DESC\_COUNT. If the value in the TargetValuePtr argument is a null pointer and the value in the ColumnNumber argument is equal to SQL\_DESC\_COUNT (when releasing the highest bound column), then SQL\_DESC\_COUNT is set to the number of the highest remaining bound column.

### Caution for SQL\_DEFAULT

The application should determine the correct length and starting point of the data in the application buffer to successfully retrieve column data. When the application explicitly specifies an TargetType, application errors are easily detected.

However, when the application specifies a `TargetType` of `SQL_DEFAULT`, `SQLBindCol` can be applied to a column of a different data type from the one data type intended by the application, either from changes to the metadata or by applying the code to a different column. In this case, the application may not always determine the start or length of the fetched column data. This may lead to unreported data errors or memory violations.

# SQLBindParameter

## Conformance

Introduced version: ODBC 2.0

Standards compliance: ODBC

## Overview

SQLBindParameter binds the buffer to the parameter marker of SQL statement.

## Syntax

```
SQLRETURN SQLBindParameter(
    SQLHSTMT      StatementHandle,
    SQLUSMALLINT  ParameterNumber,
    SQLSMALLINT   InputOutputType,
    SQLSMALLINT   ValueType,
    SQLSMALLINT   ParameterType,
    SQLULEN       ColumnSize,
    SQLSMALLINT   DecimalDigits,
    SQLPOINTER    ParameterValuePtr,
    SQLLEN        BufferLength,
    SQLLEN *      StrLen_or_IndPtr);
```

## Arguments

### StatementHandle

[Input] It is the statement handle.

### ParameterNumber

[Input] It is the parameter number which is increased sequentially from 1.

### InputOutputType

[Input] It is the parameter type.

### ValueType

[Input] It is the C data type of the parameter.

**ParameterType**

[Input] It is the SQL data type of the parameter.

**ColumnSize**

[Input] It is the size of column or expression of the parameter marker.

**DecimalDigits**

[Input] It is the number of decimal point of column or expression of the parameter marker.

**ParameterValuePtr**

[Delayed Input] It is the data buffer pointer of the parameter.

**BufferLength**

[Input/Output] It is the byte length of ParameterValuePtr buffer.

**StrLen\_or\_IndPtr**

[Delayed Input] It is the pointer to the length/indicator of the parameter.

**Returns**

SQL\_SUCCESS, SQL\_SUCCESS\_WITH\_INFO, SQL\_ERROR, SQL\_INVALID\_HANDLE

**Diagnosis**

Table 31-7 SQLSTATE values

SQLSTATE	Error	Description
07006	Restricted data type attribute violation	ValueType argument data type can not be converted into ParameterType argument data type.
07009	Invalid descriptor index	The value of ParameterNumber argument is smaller than 1.
HY000	General error	It is an error without any specific SQLSTATE.
HY001	Memory allocation error	It is a memory allocation error.
HY003	Invalid application buffer type	The value of ValueType argument is not a valid C data type.
HY004	Invalid SQL data type	The value of ParameterType argument is not a valid SQL data type.
HY009	Invalid argument value	ParameterValuePtr argument and StrLen_or_IndPtr argument are the NULL pointer, and InputOutputType argument is not SQL_PARAM_OUTPUT.  InputOutputType argument is SQL_PARAM_OUTPUT, and ParameterValuePtr argument is the NULL pointer, and C type is a character or binary, and BufferLength is greater than 0.
HY010	Function sequence error	SQL_NEED_DATA is returned after calling SQLExecute, SQLExecDirect, and this function is called before sending all data-at-execution variables.
HY021	Inconsistent descriptor information	Descriptor information is inconsistent when the integrity is checked.

SQLSTATE	Error	Description
	Information	
HY090	Invalid string or buffer length	The value of BufferLength is smaller than 0.
HY104	Invalid precision or scale value	The value specified in ColumnSize and DecimalDigits is beyond the SQL data support range of ParameterType argument.
HY105	Invalid parameter type	The value of InputOutputType argument is not valid.
HYC00	Optional feature not implemented	The driver does not support the conversion of values of ValueType argument and ParameterType argument.  The value of ParameterType argument is valid but the driver does not support.

## Description

The application calls `SQLBindParameter` to bind each parameter marker in an SQL statement. Bindings remain valid until the application calls `SQLBindParameter` again, calls `SQLFreeStmt` with the `SQL_RESET_PARAMS` option, or calls `SQLSetDescField` to set the `SQL_DESC_COUNT` header field of the APD to 0.

## ParameterNumber Argument

If `ParameterNumber` is bigger than the value of `SQL_DESC_COUNT` when calling `SQLBindParameter`, `SQLSetDescField` is called to increase the value of `SQL_DESC_COUNT` to `ParameterNumber`.

## InputOutputType Argument

The `InputOutputType` argument specifies the type of the parameter. This argument sets the `SQL_DESC_PARAMETER_TYPE` field of the IPD.

`InputOutputType` argument is one of the followings.

- `SQL_PARAM_INPUT`: The parameter marks a parameter in an SQL statement, not in a procedure nor in a `SELECT INTO` statement. For example, the parameters in `INSERT INTO Employee VALUES (?, ?, ?)` are input parameters.
  - When the statement is executed, the driver sends data for the parameter, and the `*ParameterValuePtr` buffer should contain a valid input value, or the `*StrLen_or_IndPtr` buffer should contain `SQL_NULL_DATA`, `SQL_DATA_AT_EXEC`, or the result of the `SQL_LEN_DATA_AT_EXEC` macro.
- `SQL_PARAM_INPUT_OUTPUT`: The parameter marks an input/output parameter in a procedure.
  - When the statement is executed, the driver sends data for the parameter and the `*ParameterValuePtr` buffer should contain a valid input value, or the `*StrLen_or_IndPtr` buffer should contain `SQL_NULL_DATA`, `SQL_DATA_AT_EXEC`, or the result of the `SQL_LEN_DATA_AT_EXEC` macro.
  - After the statement is executed, the driver returns data to the parameter of the application. If the data source does not return a value to an input/output parameter, the driver sets `SQL_NULL_DATA` in `*StrLen_or_IndPtr` buffer.

- **SQL\_PARAM\_OUTPUT:** The parameter marks the return value of a procedure, or an output parameter in a procedure or SELECT INTO statement. For example, the parameter in SELECT ID INTO ? FROM Employee WHERE NAME = 'Paul' is an output parameter which returns the ID.
  - After the statement is executed, the driver returns data to the parameter, if the ParameterValuePtr and StrLen\_or\_IndPtr arguments of an application are not null pointers. Otherwise, the driver discards the output value.
  - If the data source can not return a value to an output parameter, the driver sets SQL\_NULL\_DATA in \*StrLen\_or\_IndPtr buffer.

## ValueType Argument

ValueType argument specifies C data type of the parameter. It sets the values of SQL\_DESC\_TYPE, SQL\_DESC\_CONCISE\_TYPE, SQL\_DESC\_DATETIME\_INTERVAL\_CODE fields of APD.

When the ValueType argument is an interval data type,

- SQL\_DESC\_TYPE field of APD ParameterNumber record is set to SQL\_INTERVAL.
- SQL\_DESC\_CONCISE\_TYPE field is set to concise interval data type.
- SQL\_DESC\_DATETIME\_INTERVAL\_CODE field is set to subcode of a specific interval data.
- The default value of interval leading precision is (2), and the default value of interval seconds precision is (6), and they are respectively set in SQL\_DESC\_DATETIME\_INTERVAL\_PRECISION and SQL\_DESC\_PRECISION fields of APD.
- If the default precision or scale is not appropriate, the application should explicitly set the descriptor field by calling SQLSetDescField or SQLSetDescRec.

When the ValueType argument is a datetime data type,

- SQL\_DESC\_TYPE field of ParameterNumber record in APD is set to SQL\_DATETIME.
- SQL\_DESC\_CONCISE\_TYPE field is set to the concise date C data type.
- SQL\_DESC\_DATETIME\_INTERVAL\_CODE field is set to the sub code of the specific datetime data.

When the ValueType argument is an SQL\_C\_NUMERIC data type,

- The default precision is (38), the default scale is (0), and they are respectively set in SQL\_DESC\_PRECISION, SQL\_DESC\_SCALE fields of APD.
- If the default precision or scale is not appropriate, the application should explicitly set the descriptor field by calling SQLSetDescField or SQLSetDescRec.

## ParameterType Argument

ParameterType specifies the SQL data type of the parameter. It sets the values of SQL\_DESC\_TYPE, SQL\_DESC\_CONCISE\_TYPE, SQL\_DESC\_DATETIME\_INTERVAL\_CODE fields of IPD.

When the ParameterType argument is a datetime data type,



- SQL\_DESC\_TYPE field of IPD is set to SQL\_DATETIME.
- SQL\_DESC\_CONCISE\_TYPE field is set to the concise datetime SQL data type.
- SQL\_DESC\_DATETIME\_INTERVAL\_CODE field is set to the sub code of the specific datetime data.

When the ParameterType argument is a interval data type,

- SQL\_DESC\_TYPE field of IPD is set to SQL\_INTERVAL.
- SQL\_DESC\_CONCISE\_TYPE field is set to the concise SQL interval data type.
- SQL\_DESC\_DATETIME\_INTERVAL\_CODE field is set to the sub code of the specific interval data.
- The interval leading precision is set in SQL\_DESC\_DATETIME\_INTERVAL\_PRECISION field of IPD, and the interval second precision is set in SQL\_DESC\_PRECISION field of IPD.
- If the defaults of SQL\_DESC\_DATETIME\_INTERVAL\_PRECISION and SQL\_DESC\_PRECISION are not appropriate, the application sets it by calling SQLSetDescField.

When the ParameterType argument is an SQL\_NUMERIC data type,

- The default precision is (38), the default scale is (0), and they are respectively set in SQL\_DESC\_PRECISION and SQL\_DESC\_SCALE fields of IPD.
- If the default precision or scale is not appropriate, the application should explicitly set the descriptors field by calling SQLSetDescField or SQLSetDescRec.

## ColumnSize Argument

ColumnSize argument specifies the size of the column or expression corresponding the parameter marker. It sets different fields of the IPD depending on SQL data type of ParameterType.

- If ParameterType is SQL\_CHAR, SQL\_VARCHAR, SQL\_LONGVARCHAR, SQL\_BINARY, SQL\_VARBINARY, SQL\_LONGVARBINARY, concise SQL datetime, or interval data type, it sets the value of ColumnSize in SQL\_DESC\_LENGTH field of IPD.
- If ParameterType is SQL\_DECIMAL, SQL\_NUMERIC, SQL\_FLOAT, SQL\_REAL, or SQL\_DOUBLE, it sets the value of ColumnSize in SQL\_DESC\_PRECISION field of IPD.
- For other data types, ColumnSize argument is ignored.

## DecimalDigit Argument

- If ParameterType argument is SQL\_TYPE\_TIME, SQL\_TYPE\_TIMESTAMP, SQL\_INTERVAL\_SECOND, SQL\_INTERVAL\_DAY\_TO\_SECOND, SQL\_INTERVAL\_HOUR\_TO\_SECOND, or SQL\_INTERVAL\_MINUTE\_TO\_SECOND, it sets the value of DecimalDigits in SQL\_DESC\_PRECISION field of IPD.
- If ParameterType argument is SQL\_NUMERIC or SQL\_DECIMAL, it sets the value of DecimalDigits in SQL\_DESC\_SCALE field of IPD.
- For other data types, DecimalDigits argument is ignored.

## ParameterValuePtr Argument

When calling `SQLExecute` and `SQLExecDirect`, `ParameterValuePtr` points to the actual data for the parameter. The data type should be in a form specified by `ValueType` argument. This argument sets the `SQL_DESC_DATA_PTR` field of the APD.

If `*StrLen_or_IndPtr` is the result of the `SQL_LEN_DATA_AT_EXEC` (length) macro or `SQL_DATA_AT_EXEC`, then `ParameterValuePtr` is an application-defined pointer value which is related to the parameter. It is returned to the application through `SQLParamData`.

For example, `ParameterValuePtr` might be a non-zero token such as a parameter number, a pointer to data, or a pointer to a structure that the application used to bind input parameters.

If `InputOutputType` argument is `SQL_PARAM_INPUT_OUTPUT` or `SQL_PARAM_OUTPUT`, `ParameterValuePtr` should be a buffer pointer in which the output value is stored.

If the value in the `SQL_ATTR_PARAMSET_SIZE` statement attribute is bigger than 1, `ParameterValuePtr` points to an array. A single SQL statement processes the complete array of input values for an input or input/output parameter and returns an array of output values for an input/output or output parameter.

## BufferLength Argument

For character and binary C data, the `BufferLength` argument specifies the length of the `*ParameterValuePtr` buffer (if the value in the `SQL_ATTR_PARAMSET_SIZE` statement attribute is 1), or specifies the length of the element in the `*ParameterValuePtr` array (if the value in the `SQL_ATTR_PARAMSET_SIZE` statement attribute is bigger than 1).

Both when input and output, `BufferLength` is used to determine the position in the array of `*ParameterValuePtr` for. It sets `SQL_DESC_OCTET_LENGTH` field of APD.

For an input/output parameter and an output parameter, `BufferLength` is used to determine whether or not to truncate the output.

- For character C data, if the number of bytes available to return is equal to or bigger than `BufferLength`, the data in `*ParameterValuePtr` is truncated to `BufferLength` minus 1 bytes and it is null-terminated.
- For binary C data, if the number of bytes available to return is equal to or bigger than `BufferLength`, the data in `*ParameterValuePtr` is truncated to `BufferLength` bytes.
- For other C data types, the `BufferLength` argument is ignored.

## StrLen\_or\_IndPtr Argument

The `StrLen_or_IndPtr` argument contains one of the followings when `SQLExecute` or `SQLExecDirect` is called. (This argument sets the `SQL_DESC_OCTET_LENGTH_PTR` and `SQL_DESC_INDICATOR_PTR` of APD.)

- The length of the parameter value stored in \*ParameterValuePtr. This is ignored except for character or binary C data.
- SQL\_NTS: The parameter value is a null-terminated string.
- SQL\_NULL\_DATA: The parameter value is NULL.
- The result of the SQL\_LEN\_DATA\_AT\_EXEC(length) macro: The data for the parameter will be sent when performing SQLPutData.
  - If the ParameterType argument is SQL\_LONGVARIABLE, SQL\_LONGVARCHAR, or a long, and SQL\_NEED\_LONG\_DATA\_LEN information of SQLGetInfo returns "Y", then the length is the number of bytes of data to be sent for the parameter
  - If SQL\_NEED\_LONG\_DATA\_LEN information of SQLGetInfo is "N", length should be a nonnegative value and is ignored.
  - For example, to specify 10,000 bytes of SQL\_LONGVARIABLE parameter data to be sent by calling SQLPutData for multiple times, \*StrLen\_or\_IndPtr should be set to SQL\_LEN\_DATA\_AT\_EXEC(10000).
- SQL\_DATA\_AT\_EXEC: The data for the parameter will be sent when performing SQLPutData.

If StrLen\_or\_IndPtr is a null pointer, the driver assumes that all input parameter values are non-NULL and that character and binary data is null-terminated. If InputOutputType is SQL\_PARAM\_OUTPUT, and ParameterValuePtr and StrLen\_or\_IndPtr are both null pointers, the driver discards the output value.

If the InputOutputType argument is SQL\_PARAM\_INPUT\_OUTPUT, SQL\_PARAM\_OUTPUT, then StrLen\_or\_IndPtr points to SQL\_NULL\_DATA, the number of bytes available to return in \*ParameterValuePtr (excluding the null-termination byte of character data), or SQL\_NO\_TOTAL (if the number of bytes available to return cannot be determined).

If the value in the SQL\_ATTR\_PARAMSET\_SIZE statement attribute is greater than 1, StrLen\_or\_IndPtr points to an array of SQLLEN values.

## Passing Parameter Values

An application can pass the value for a parameter by calling the \*ParameterValuePtr buffer or multiple SQLPutData. Parameters whose data is passed through SQLPutData are known as data-at-execution parameters. These are typically used to send data for SQL\_LONGVARIABLE and SQL\_LONGVARCHAR parameters, and can be mixed with other parameters.

The application should perform the following process to pass the parameter values.

1. It calls SQLBindParameter for each parameter to bind buffers for the parameter's value (ParameterValuePtr argument) and length/indicator (StrLen\_or\_IndPtr argument). For data-at-execution parameters, ParameterValuePtr is an application-defined pointer value such as a parameter number or a pointer to data. The value will be returned later and can be used to identify the parameter.
2. It sets values for an input parameter or an input/output parameter in the \*ParameterValuePtr and \*StrLen\_or\_IndPtr buffers.

- For normal parameters, the application inputs the parameter value in the \*ParameterValuePtr buffer and the length of that value in the \*StrLen\_or\_IndPtr buffer.
  - For data-at-execution parameters, the application inputs the result of the SQL\_LEN\_DATA\_AT\_EXEC (length) macro (when calling an ODBC 2.0 driver) in the \*StrLen\_or\_IndPtr buffer.
3. It calls SQLExecute or SQLExecDirect to execute the SQL statement.
    - If data-at-execution parameters do not exist, the process is complete.
    - If any data-at-execution parameters exist, the function returns SQL\_NEED\_DATA.
  4. It calls SQLParamData to retrieve the application-defined value specified in the ParameterValuePtr argument of SQLBindParameter for the first data-at-execution parameter to be processed. SQLParamData returns SQL\_NEED\_DATA.



Although data-at-execution parameters resemble data-at-execution columns, the value returned by SQLParamData is different for each.

Data-at-execution parameters are parameters in an SQL statement for which data will be sent to SQLPutData when the statement is executed together with SQLExecDirect or SQLExecute. They are bound with SQLBindParameter.

The value returned by SQLParamData is a pointer value passed to the ParameterValuePtr argument of SQLBindParameter. Data-at-execution columns are columns in a rowset for which data will be sent when a row is updated or added with SQLBulkOperations or updated with SQLSetPos. They are bound with SQLBindCol. The value returned by SQLParamData is the address of the row in the TargetValuePtr\* buffer (set by a call to \*\*SQLBindCol) which is to be processed.

5. It calls SQLPutData for one or more times to send data for the parameter. One or more calls are required if the data value is bigger than what is specified in the \*ParameterValuePtr buffer of SQLPutData. Multiple SQLPutData calls for the same parameter are allowed only when sending character C data to a column with a character, binary, or data source-specific data type or when sending binary C data to a column with a character, binary, or data source-specific data type.
6. It calls SQLParamData again to signal that all data has been sent for the parameter.
  - If one or more data-at-execution parameters exist, SQLParamData returns SQL\_NEED\_DATA and processes the application-defined value for the next data-at-execution parameter. The application repeats steps 4 and 5.
  - If data-at-execution parameter does not exist, the process is complete. If the statement was successfully executed, SQLParamData returns SQL\_SUCCESS or SQL\_SUCCESS\_WITH\_INFO. If the execution failed, it returns SQL\_ERROR. At this point, SQLParamData can be returned by any SQLSTATE. It can also be returned by SQLExecDirect or SQLExecute which is used to execute the statement.
  - Output values for any input/output or output parameters are available in the \*ParameterValuePtr and

d \*StrLen\_or\_IndPtr buffers after the application retrieves all result sets generated by the statement.

Calling `SQLExecute` or `SQLExecDirect` puts the statement in an `SQL_NEED_DATA` state. At this point, the application can call only `SQLCancel`, `SQLGetDiagField`, `SQLGetDiagRec`, `SQLGetFunctions`, `SQLParamData`, or `SQLPutData` together with the statement or the connection handle related to the statement.

If it calls any other function for the statement or the connection related to the statement, the function returns `SQLSTATE HY010`(Function sequence error). The statement is released from the `SQL_NEED_DATA` state when `SQLParamData` or `SQLPutData` returns an error, `SQLParamData` returns `SQL_SUCCESS` or `SQL_SUCCESS_WITH_INFO`, or the statement is canceled.

If the application calls `SQLCancel` while the driver still needs data for data-at-execution parameters, the driver cancels statement execution. Then the application can call `SQLExecute` or `SQLExecDirect` again.

## Using Parameter Array

An application prepares a statement together with parameter markers and passes it in an array of parameters in the following two ways.

- One method is for the driver to rely on the array-processing capabilities, in this case the entire statement with the array of parameters is treated as one atomic unit. Oracle is an example of a data source which supports array processing capabilities.
- The other method is for the driver to generate a batch of SQL statements. Each set of parameters in the parameter array is allocated per an SQL statement and is made into a batch, then the batch is executed. Arrays of parameters can not be used in an `UPDATE WHERE CURRENT OF` statement.

When processing the parameter array, the number of each result sets/ rows are available per each parameter set or the number of each result sets/ rows are available in whole. The `SQL_PARAM_ARRAY_ROW_COUNTS` option in `SQLGetInfo` indicates whether the number of rows are available for each set of parameters(`SQL_PARC_BATCH`) or only a single row is available (`SQL_PARC_NO_BATCH`).

The `SQL_PARAM_ARRAY_SELECTS` option in `SQLGetInfo` indicates whether a result set is available for each set of parameters (`SQL_PAS_BATCH`) or is available only in one result set(`SQL_PAS_NO_BATCH`). If the driver does not allow a result set-generating statement to be executed together with an array of parameters, `SQL_PARAM_ARRAY_SELECTS` returns `SQL_PAS_NO_SELECT`.

For more information, refer to **SQLGetInfo**.

To support the parameter array, the `SQL_ATTR_PARAMSET_SIZE` statement attribute is set to specify the number of values for each parameter. If the field is bigger than 1, the `SQL_DESC_DATA_PTR`, `SQL_DESC_INDICATOR_PTR`, and `SQL_DESC_OCTET_LENGTH_PTR` fields of the APD should point to arrays. The number of elements in each array is equal to the value of `SQL_ATTR_PARAMSET_SIZE`.

The `SQL_DESC_ROWS_PROCESSED_PTR` field of the APD points to a buffer which contains the number of sets of parameters which have been processed, including error sets. As like each processed parameters set, the driver stores a new value in the buffer. Any number will not be returned if this is a null pointer. When arrays of parameters are used, the value pointed to by the `SQL_DESC_ROWS_PROCESSED_PTR` field of the APD is generated even when `SQL_ERROR` is returned by the setting function. If `SQL_NEED_DATA` is returned, the value pointed to by the `SQL_DESC_ROWS_PROCESSED_PTR` field of the APD is set to the set of parameters which is being processed.

## Binding Column-wise Parameter

For column-wise binding, the application binds the separate parameter and length/indicator arrays to each parameter.

For column-wise binding, the application firstly sets the `SQL_ATTR_PARAM_BIND_TYPE` statement attribute to `SQL_PARAM_BIND_BY_COLUMN`. (It is the default value.) The application performs the following processes to use column-wise binding.

1. It allocates the parameter buffer array.
2. It allocates the length/indicator buffer array.



If the application directly records to the descriptors when using the column-wise binding, the separate arrays can be used for length and indicator data.

3. It calls `SQLBindParameter` together with the following arguments.
  - `ValueType` is the C type of a single element in the parameter buffer array.
  - `ParameterType` is the SQL type of the parameter.
  - `ParameterValuePtr` is the address of the parameter buffer array.
  - `BufferLength` is the size of a single element in the parameter buffer array. The `BufferLength` argument is ignored when the data is fixed-length data.

## Binding Row-wise Parameter

For row-wise binding, the application defines a structure which contains parameter and length/indicator buffers for each parameter to be bound.

The application performs the following processes to use row-wise binding.

1. It defines a structure to hold a single set of parameters (including both parameter and length/indicator buffers) and allocates an array of these structures.



If the application directly records to the descriptors when using the row-wise binding, the separate fields can be used for length and indicator data.

2. `SQL_ATTR_PARAM_BIND_TYPE` statement attribute sets the size of the structure which contains a single set of parameters or to the size of an instance of a buffer into which the parameters will be bound. The length should include space for all bound parameters. The length should include space for binding parameter and the structure buffer, or should be buffered to ensure the result to point to the beginning of the next parameter when the address of a bound parameter is incremented to the specified length. ANSI C guarantees it by using the `sizeof` operator.
3. It calls `SQLBindParameter` together with the following arguments for each parameter to be bound.
  - `ValueType` is the type of the parameter buffer member to be bound to the column.
  - `ParameterType` is the SQL type of the parameter.
  - `ParameterValuePtr` is the address of the parameter buffer member in the first array element.
  - `BufferLength` is the size of the parameter buffer member.
  - `StrLen_or_IndPtr` is the address of the length/indicator member to be bound.

## Error Information

If a driver does not perform parameter arrays as same as batches (the `SQL_PARAM_ARRAY_ROW_COUNTS` option is as same as `SQL_PARC_NO_BATCH`), error situations are handled as if one statement were executed.

If the driver performs parameter arrays as batches, an application can use the `SQL_DESC_ARRAY_STATUS_PTR` header field of the IPD to determine if a parameter of an SQL statement or a parameter in an array of parameters caused `SQLExecDirect` or `SQLExecute` to return an error.

This field contains status information for each row of parameter values. If the field represents that an error occurs, fields in the diagnostic data structure will represent the row and parameter number of the failed parameter. The number of columns in the array will be defined by the `SQL_DESC_ARRAY_SIZE` header field in the APD, and it can be set by the `SQL_ATTR_PARAMSET_SIZE` statement attribute.



The `SQL_DESC_ARRAY_STATUS_PTR` header field in the APD is used to ignore parameters. For more information about ignoring parameters, refer to **Ignoring Parameter Set**.

When `SQLExecute` or `SQLExecDirect` returns `SQL_ERROR`, the elements in the array pointed to by the `SQL_DESC_ARRAY_STATUS_PTR` field in the IPD contain `SQL_PARAM_ERROR`, `SQL_PARAM_SUCCESS`, `SQL_PARAM_SUCCESS_WITH_INFO`, `SQL_PARAM_UNUSED`, or `SQL_PARAM_DIAG_UNAVAILABLE`.

For each element in this array, the diagnostic data structure contains one or more status records. The `SQL_DIAG_ROW_NUMBER` field of the structure represents the row number of the parameter values which c

caused the error. If it is possible to determine the particular parameter in a row of parameters which caused the error, the parameter number will be entered in the SQL\_DIAG\_COLUMN\_NUMBER field.

SQL\_PARAM\_UNUSED is set when a parameter is not used due to an error because SQLExecute or SQLExecDirect forcibly canceled an earlier parameter. For example, if 50 parameters exist and an error occurred while executing the 40th set of parameters which caused the cancellation by SQLExecute or SQLExecDirect, then SQL\_PARAM\_UNUSED is set in the status array for parameters from 41 to 50.

SQL\_PARAM\_DIAG\_UNAVAILABLE is set when the driver treats arrays of parameters as a single unit, so it does not generate individual error information of parameter level.

Some errors in the processing of a single set of parameters cause processing of the subsequent sets of parameters in the array to stop. Other errors do not affect the processing of subsequent parameters. The driver defines which errors will stop processing. If processing does not stop, all parameters in the array are processed, SQL\_SUCCESS\_WITH\_INFO is returned as a result of the error, and the buffer defined by SQL\_ATTR\_PARAMS\_PROCESSED\_PTR is set to the total number of sets of parameters processed which includes error sets.



ODBC behavior when an error occurs in the processing of an array of parameters is different between ODBC 3.x and ODBC 2.x.

In ODBC 2.x, the function returns SQL\_ERROR and stops the processing. The buffer pointed to by the pirow argument of SQLParamOptions contained the number of the error row.

In ODBC 3.x, the function returns SQL\_SUCCESS\_WITH\_INFO, and it may stop or continue processing. If it continues, the buffer specified by SQL\_ATTR\_PARAMS\_PROCESSED\_PTR will be set to the value of all parameters processed, including those which resulted in an error. This change in behavior can cause problems for existing applications.

When SQLExecute or SQLExecDirect returns SQL\_ERROR or SQL\_NEED\_DATA before completing the processing of all parameter sets in a parameter array, the status array contains statuses for those parameters which have already been processed.

The location pointed to by the SQL\_DESC\_ROWS\_PROCESSED\_PTR field in the IPD contains the row number in the parameter array which caused the SQL\_ERROR or SQL\_NEED\_DATA error code. When an array of parameters is sent to a SELECT statement, the availability of status array values is defined by the driver. They are available after the statement is executed or result sets are fetched.

## Ignoring Parameter Set

SQL\_DESC\_ARRAY\_STATUS\_PTR field of APD can be used to indicate the binding parameter set which should be ignored in SQL statement. The application should perform the following processes in order that t



he driver directly ignores one or more parameter sets during the execution.

1. It calls `SQLSetDescField` in order that the header field of `SQL_DESC_ARRAY_STATUS_PTR` of APD points to an array of `SQLUSMALLINT` values including the status information. The field also can be set through `SQL_ATTR_PARAM_OPERATION_PTR` of Attribute argument in `SQLSetStmtAttr`, and it allows to set the field without a descriptor handle which is the application.
2. It sets each element of the array defined by `SQL_DESC_ARRAY_STATUS_PTR` of APD to one of the following two values.
  - `SQL_PARAM_IGNORE`: The row is excluded from the execution of the statement.
  - `SQL_PARAM_PROCEED`: The row is included in the execution of the statement.
3. It calls `SQLExecDirect` or `SQLExecute`, and executes the prepared statement. It applies the following rules to the array defined by `SQL_DESC_ARRAY_STATUS_PTR` of APD.
  - The pointer is set to `NULL` by default.
  - If the pointer is `NULL`, all parameter set are used as if all elements are set to `SQL_ROW_PROCEED`.
  - Setting the element to `SQL_PARAM_PROCEED` does not guarantee that the operation would use the specific parameter set.
  - `SQL_PARAM_PROCEED` is defines as 0 in the header file.

An application can set `SQL_DESC_ARRAY_STATUS_PTR` field of APD to refer to the same array as `SQL_DESC_ARRAY_STATUS_PTR` field of IRD. It is very useful when binding the parameters to the row data. The parameters may be ignored depending on the status of row data.

Along with `SQL_PARAM_IGNORE`, the following status codes are to ignore the parameter set in the SQL statement.

- `SQL_ROW_DELETED`
- `SQL_ROW_UPDATED`
- `SQL_ROW_ERROR`

Along with `SQL_PARAM_PROCEED`, the following status codes are to process the parameter set in the SQL statement.

- `SQL_ROW_SUCCESS`
- `SQL_ROW_SUCCESS_WITH_INFO`
- `SQL_ROW_ADDED`

## Rebinding Parameter

The application can include many parameters, but if there is a buffer area for calling `SQLExecDirect` or `SQLExecute` which uses only some parameters, rebinding the parameter is particularly useful. The remaining space of buffer area can be used to set the next parameter by modifying the existing binding through off

set.

The `SQL_DESC_BIND_OFFSET_PTR` header field of APD points to the binding offset. If the field is not NULL, the driver dereferences to the pointer. If values of `SQL_DESC_DATA_PTR`, `SQL_INDICATOR_PTR` do not exist, and `SQL_DESC_OCTET_LENGTH_PTR` field is the NULL pointer, then the dereferenced value is added to the fields in the descriptor records during the execution time.

Offset is valid after rebinding. The application can directly modify the offset without calling `SQLSetDescField` or `SQLSetDescRec` to update the descriptor field because `SQL_DESC_BIND_OFFSET_PTR` field is the pointer to offset rather than the offset itself. The pointer is NULL by default.

`SQL_DESC_BIND_OFFSET_PTR` field of ARD can be set by calling `SQLSetDescField` or through `SQL_ATTR_PARAM_BIND_OFFSET_PTR` in Attribute argument of `SQLSetStmtAttr`. The offset binding always adds the value directly to `SQL_DESC_DATA_PTR`, `SQL_DESC_INDICATOR_PTR` and `SQL_DESC_OCTET_LENGTH_PTR`. If offset is changed to another value, the new value is continuously added directly to each descriptor field. The new offset is not added to the previous one.

## Descriptor

The way which the parameter is bound is determined by APD and the IPD fields. The arguments in `SQLBindParameter` are used to set the descriptor fields. It is more effective to use the `SQLBindParameter` because the application can call `SQLBindParameter` without obtaining the descriptor handle, but the fields can also be set by the `SQLSetDescField` function.



Calling `SQLBindParameter` for a single statement may affect other statements. It occurs when ARD related to the statement is explicitly allocated and it is related to other statements. The modifications for the field affects all statements related the descriptor because `SQLBindParameter` modifies the fields of ARD. If it is not the required behavior, the application should release the relationship between the descriptor and other statements before calling `SQLBindParameter`.

Notionally, `SQLBindParameter` should perform the following processes.

1. It calls `SQLGetStmtAttr`, and obtains the APD handle.
2. It calls `SQLGetDescField`, and obtains `SQL_DESC_COUNT` field of APD is obtained. If the value of `ColumnNumber` exceeds the value of `SQL_DESC_COUNT`, then it calls `SQLSetDescField` to increase the value of `SQL_DESC_COUNT` to the value of `ColumnNumber`.
3. It calls `SQLSetDescField` multiple times, and sets the values of the following fields of APD.
  - It sets `SQL_DESC_TYPE` and `SQL_DESC_CONCISE_TYPE` to the value of `ValueType`.
    - It excludes `ValueType` if `ValueType` is one of the implied identifiers in `datetime` or `interval` sub format. It sets `SQL_DESC_TYPE` to `SQL_DATETIME` or `SQL_INTERVAL`, and it sets `SQL_DESC_CONCI`

SE\_TYPE to the implied identifier, and sets SQL\_DESC\_DATETIME\_INTERVAL\_CODE to the corresponding datetime or interval subcode.

- It sets SQL\_DESC\_OCTET\_LENGTH field to the value of BufferLength.
  - It sets SQL\_DESC\_DATA\_PTR field to the value of ParameterValue.
  - It sets SQL\_DESC\_OCTET\_LENGTH\_PTR field to the value of StrLen\_or\_Ind.
  - It also sets SQL\_DESC\_INDICATOR\_PTR field to the value of StrLen\_or\_Ind.
  - StrLen\_or\_Ind specifies both the indicator information and length of parameter value.
4. It calls SQLGetStmtAttr, and obtains the IPD handle.
  5. It calls SQLGetDescField, and obtains SQL\_DESC\_COUNT field of IPD. If the value of ColumnNumber exceeds the value of SQL\_DESC\_COUNT, then it calls SQLSetDescField to increase the value of SQL\_DESC\_COUNT to the value of ColumnNumber.
  6. It calls SQLSetDescField multiple times, and sets the values of following fields of IPD.
    - It sets SQL\_DESC\_TYPE and SQL\_DESC\_CONCISE\_TYPE to the value of ParameterType.
      - It excludes ParameterType, if ParameterType is one of the implied identifiers with datetime or interval sub format. It sets SQL\_DESC\_TYPE to SQL\_DATETIME or SQL\_INTERVAL, and it sets SQL\_DESC\_CONCISE\_TYPE to the implied identifier, and sets SQL\_DESC\_DATETIME\_INTERVAL\_CODE to the corresponding datetime or interval subcode.
    - It sets one or more SQL\_DESC\_LENGTH, SQL\_DESC\_PRECISION and SQL\_DESC\_DATETIME\_INTERVAL\_PRECISION for ParameterType, properly.
    - It sets SQL\_DESC\_SCALE to the value of DecimalDigits.

If it failed to call SQLBindParameter, the contents of the descriptor fields to be set in APD are not defined and SQL\_DESC\_COUNT field of APD is not changed. Additionally, SQL\_DESC\_LENGTH, SQL\_DESC\_PRECISION, SQL\_DESC\_SCALE, and SQL\_DESC\_TYPE fields of the proper record in IPD are not defined and SQL\_DESC\_COUNT field of IPD is not changed.

# SQLBrowseConnect

It is not supported.

## Conformance

Introduced version: ODBC 1.0

Standards compliance: ODBC

## Overview

SQLBrowseConnect finds the attribute and its value which are required to connect to the data source, and supports a method for the iterative list.

## Syntax

```
SQLRETURN SQLBrowseConnect(  
    SQLHDBC          ConnectionHandle,  
    SQLCHAR *        InConnectionString,  
    SQLSMALLINT      StringLength1,  
    SQLCHAR *        OutConnectionString,  
    SQLSMALLINT      BufferLength,  
    SQLSMALLINT *    StringLength2Ptr);
```

# SQLBulkOperations

It is not supported.

## Conformance

Introduced version: ODBC 3.0

Standards compliance: ODBC

## Overview

SQLBulkOperations performs the massive bookmark operations such as the bulk inserts, and the updates, deletes, fetches through the bookmark.

## Syntax

```
SQLRETURN SQLBulkOperations(  
    SQLHSTMT      StatementHandle,  
    SQLUSMALLINT  Operation);
```

# SQLCancel

It is not supported.

## Conformance

Introduced version: ODBC 1.0

Standards compliance: ISO 92

## Overview

SQLCancel cancels the statement in progress.

Use **SQLCancelHandle** function to cancel the connection or statement in progress.

## Syntax

```
SQLRETURN SQLCancel(  
    SQLHSTMT    StatementHandle);
```

# SQLCancelHandle

It is not supported.

## Conformance

Introduced version: ODBC 3.8

Standards compliance: It is not available.

## Overview

SQLCancelHandle cancels processing of the connection or the statement.

## Syntax

```
SQLRETURN SQLCancelHandle(  
    SQLSMALLINT HandleType,  
    SQLHANDLE Handle);
```

# SQLCloseCursor

## Conformance

Introduced version: ODBC 3.0

Standards compliance: ISO 92

## Overview

SQLCloseCursor closes an open cursor on the statement and discards the remaining results.

## Syntax

```
SQLRETURN SQLCloseCursor(  
    SQLHSTMT    StatementHandle);
```

## Arguments

### StatementHandle

[Input] It is the statement handle.

## Returns

SQL\_SUCCESS, SQL\_SUCCESS\_WITH\_INFO, SQL\_ERROR, SQL\_INVALID\_HANDLE

## Diagnosis

SQLSTATE	Error	Description
24000	Invalid cursor state	Open cursor does not exist on the statement.
HY000	General error	It is an error without any specific SQLSTATE.
HY001	Memory allocation error	It is a memory allocation error.
HY010	Function sequence error	SQL_NEED_DATA is returned after calling SQLExecute, SQLExecDirect, the function is called before sending all data-at-execution parameters.



## Description

If open cursor does not exist, `SQLCloseCursor` returns `SQLSTATE 24000`(Invalid cursor state). Calling `SQLCloseCursor` is as same as calling `SQLFreeStmt` with `SQL_CLOSE` option. However, when open cursor does not exist, `SQLCloseCursor` returns `SQLSTATE 24000` (Invalid cursor state), but calling `SQLFreeStmt` does not affect the application.

# SQLColAttribute

## Conformance

Introduced version: ODBC 3.0

Standards compliance: ISO 92

## Overview

SQLColAttribute returns the descriptor information for the result set column. The descriptor information is returned as a string or integer value.

## Syntax

```
SQLRETURN SQLColAttribute (  
    SQLHSTMT      StatementHandle,  
    SQLUSMALLINT  ColumnNumber,  
    SQLUSMALLINT  FieldIdentifier,  
    SQLPOINTER    CharacterAttributePtr,  
    SQLSMALLINT   BufferLength,  
    SQLSMALLINT * StringLengthPtr,  
    SQLLEN *      NumericAttributePtr);
```

## Arguments

### StatementHandle

[Input] It is the statement handle.

### ColumnNumber

[Input] It is the record number to retrieve for a field value in IRD. It starts from 1 and corresponds to the column number of result data which sequentially increases. The column can be described in random order.

The number 0 column can be specified to ColumnNumber, but the undefined value is returned except for SQL\_DESC\_TYPE and SQL\_DESC\_OCTET\_LENGTH.

### FieldIdentifier

[Input] It is the descriptor handle. It defines the field retrieved in IRD. (e.g. SQL\_COLUMN\_TABLE\_NAME)

**CharacterAttributePtr**

[Output] It is the buffer pointer returning the field value when the value of FieldIdentifier field of the ColumnNumber column of IRD is a string. If the field value is not a string, it is not used.

If CharacterAttributePtr is NULL, StringLengthPtr returns the total number of bytes which can be returned. (Except for null-termination character)

**BufferLength**

[Input] It is the length of \*CharacterAttributePtr when FieldIdentifier is defined in ODBC and CharacterAttributePtr points to a string or binary buffer. If FieldIdentifier is defined in ODBC and \*CharacterAttributePtr is an integer, it is ignored.

**StringLengthPtr**

[Output] It is the pointer returning the total number of bytes which can be returned in \*CharacterAttributePtr. (Except for null-termination character for the character data)

For the character data, if the number of bytes which can be returned is equal to or bigger than BufferLength, the description information of \*CharacterAttributePtr is truncated to the length of BufferLength minus 1, and it is null terminated by the driver.

For other data types, the value of BufferLength is ignored.

**NumericAttributePtr**

[Output] It is the buffer pointer which returns the field value when the value of FieldIdentifier field of the ColumnNumber column of IRD is a number such as SQL\_DESC\_COLUMN\_LENGTH. If the field value is not a number, it is not used.

**Returns**

SQL\_SUCCESS, SQL\_SUCCESS\_WITH\_INFO, SQL\_STILL\_EXECUTING, SQL\_ERROR, SQL\_INVALID\_HANDLE

**Diagnosis**

SQLSTATE	Error	Description
01004	String data, right truncated	*CharacterAttributePtr buffer is not large enough to return the entire string, so the string is truncated. The length of string not truncated is returned to *StringLengthPtr. (The function returns SQL_SUCCESS_WITH_INFO.)
07005	Prepared statement not a cursor-specification	The statement does not return the result set, and FieldIdentifier is not SQL_DESC_COUNT. The column to explain does not exist.
07009	Invalid descriptor index	The value of ColumnNumber argument is bigger than the number of columns in the result set.
HY000	General error	It is an error without any specific SQLSTATE.
HY001	Memory allocation error	It is a memory allocation error.

SQLSTATE	Error	Description
HY010	Function sequence error	This function is called before SQLPrepre, SQLExecDirect, the catalog function. After calling SQLExecute, SQLExecDirect, then SQL_NEED_DATA is returned, and this function is called before sending all data-at-execution variables.
HY090	Invalid string or buffer length	*CharacterAttributePtr is a string, BufferLength is smaller than 0 but it is not SQL_NTS.
HY091	Invalid descriptor field identifier	The value of FieldIdentifier argument is not defined.

## Description

SQLColAttribute returns information to \*NumericAttributePtr or \*CharacterAttributePtr. Integer information is returned as SQLLEN value to \*NumericAttributePtr. All other data type information is returned to \*CharacterAttributePtr. When information is returned to \*NumericAttributePtr, the driver ignores CharacterAttributePtr, BufferLength, StringLengthPtr. When the information is returned to \*CharacterAttributePtr, the driver ignores NumericAttributePtr.

SQLColAttribute returns the value in the descriptor field of IRD. The value of FieldIdentifier returned to SQLColAttribute can be obtained by calling SQLGetDescField with appropriate IRD handle.

The following table is the descriptor types returned to SQLColAttribute. The type of NumericAttributePtr is SQLLEN\*.

FieldIdentifier	Information return	Description
SQL_DESC_AUTO_UNIQUE_VALUE (ODBC 1.0)	NumericAttributePtr	<ul style="list-style-type: none"> <li>SQL_TRUE: It is an auto increment column.</li> <li>SQL_FALSE: It is neither an auto increment column nor a numeric type.</li> </ul>
SQL_DESC_BASE_COLUMN_NAME (ODBC 3.0)	CharacterAttributePtr	<p>It is the default column name for the result set columns. If the default column name does not exist(in case of an expression column), the variable will contain an empty string.</p> <p>This information is returned in the record field of SQL_DESC_BASE_COLUMN_NAME which is the read-only field of IRD.</p>
SQL_DESC_BASE_TABLE_NAME (ODBC 3.0)	CharacterAttributePtr	<p>It is the base table name which contains the column. If the base table name can not be defined or is not applicable the variable contains an empty string.</p> <p>This information is returned in the record field of SQL_DESC_BASE_TABLE_NAME which is the read-only field of IRD.</p>
SQL_DESC_CASE_SENSITIVE (ODBC 1.0)	NumericAttributePtr	<ul style="list-style-type: none"> <li>SQL_TRUE: The column is case-sensitive for sorting or comparisons.</li> <li>SQL_FALSE: The column is neither case-sensitive for sorting or comparison nor is a character.</li> </ul>

FieldIdentifier	Information return	Description
SQL_DESC_CATALOG_NAME (ODBC 2.0)	CharacterAttributePtr	It is the catalog of the table containing the column.
SQL_DESC_CONCISE_TYPE (ODBC 1.0)	NumericAttributePtr	It is concise data type. For datetime and interval data, the concise data such as SQL_TYPE_TIME, SQL_INTERVAL_YEAR is returned.  This information is returned in the record field of SQL_DESC_CONCISE_TYPE of IRD.
SQL_DESC_COUNT (ODBC 1.0)	NumericAttributePtr	It is the number of columns which can be used in the result set. If column does not exist in the result set, 0 is returned. ColumnNumber argument is ignored.  This information is returned in the header field of SQL_DESC_COUNT of IRD.
SQL_DESC_DISPLAY_SIZE (ODBC 1.0)	NumericAttributePtr	It is the maximum number of characters required to display the column.
SQL_DESC_FIXED_PREC_SCALE (ODBC 1.0)	NumericAttributePtr	<ul style="list-style-type: none"> <li>SQL_TRUE: The column has the fixed precision and non-zero scale.</li> <li>SQL_FALSE: The column does not have the fixed precision but it has the non-zero scale.</li> </ul>
SQL_DESC_LABEL (ODBC 2.0)	CharacterAttributePtr	It is the column label or title. For example, the column name, EmpName, can be displayed as employee name or alias. If the label does not exist, the column name is returned. If a label or name is not specified to the column, an empty string is returned.
SQL_DESC_LENGTH (ODBC 3.0)	NumericAttributePtr	It is the maximum or actual length of data of the string or binary data type. A fixed length data type is the maximum character length, and a variable-length data type is the actual character length. This value always excludes the null-termination byte of the string at the end.  This information is returned in the record field of SQL_DESC_LENGTH of IRD.
SQL_DESC_LITERAL_PREFIX (ODBC 3.0)	CharacterAttributePtr	This VARCHAR (128) record field contains a character or string which the driver recognizes the prefix of the data type. The data type to which a prefix is not applied contains an empty string.
SQL_DESC_LITERAL_SUFFIX (ODBC 3.0)	CharacterAttributePtr	This VARCHAR (128) record field contains a character or string which the driver recognizes the suffix of the data type. The data type to which a suffix is not applied contains an empty string.
SQL_DESC_LOCALIZED_TYPE_NAME (ODBC 3.0)	CharacterAttributePtr	The VARCHAR (128) record field contains the localized (native language) name of data type which is different from the regular name of data type. If the localized name does not exist, an empty string is returned. This field is only for display purposes. The character set of string depends on the locale, and the default is usually the character set of the server.
		It is the column alias of when the column alias is applied. If the column alias

FieldIdentifier	Information return	Description
SQL_DESC_NAME (ODBC 3.0)	CharacterAttributePtr	<p>is not applied, the column name is returned. In both cases, SQL_DESC_UNNAMED is set to SQL_NAMED. If column name or alias does not exist, an empty string is returned, and SQL_DESC_UNNAMED is set to SQL_UNNAMED.</p> <p>This information is returned in the record field of SQL_DESC_NAME of IRD.</p>
SQL_DESC_NULLABLE (ODBC 3.0)	NumericAttributePtr	<ul style="list-style-type: none"> <li>SQL_NULLABLE: The column can have NULL value.</li> <li>SQL_NO_NULLS: The column can not have NULL value.</li> <li>SQL_NULLABLE_UNKNOWN: It is unknown whether NULL value is allowed for the column.</li> </ul> <p>This information is returned in the record field of SQL_DESC_NULLABLE of IRD.</p>
SQL_DESC_NUM_PREC_RADIX (ODBC 3.0)	NumericAttributePtr	<p>If the data type of SQL_DESC_TYPE field is the approximate numeric data type, this field contains 2 because SQL_DESC_PRECISION field contains the number of bits. If the data type of SQL_DESC_TYPE field is the exact numeric data type, this field contains 10 because SQL_DESC_PRECISION field contains the number of decimal digits. This field is set to 0 for all non-numeric data types.</p>
SQL_DESC_OCTET_LENGTH (ODBC 3.0)	NumericAttributePtr	<p>It is byte length of string or binary data type. For a fixed-length character or binary data type, it is the actual byte length. For a variable-length character or binary data type, it is the maximum length in bytes. This value does not include null termination.</p> <p>This information is returned in the record field of SQL_DESC_OCTET_LENGTH of IRD.</p>
SQL_DESC_PRECISION (ODBC 3.0)	NumericAttributePtr	<p>It is the precision applicable to the numeric data type. For SQL_TYPE_TIME, SQL_TYPE_TIMESTAMP, all interval data types representing time interval, the value is the applicable fractional seconds precision.</p> <p>This information is returned in the record field of SQL_DESC_PRECISION of IRD.</p>
SQL_DESC_SCALE (ODBC 3.0)	NumericAttributePtr	<p>It is the scale applicable to the numeric data type. For DECIMAL or NUMERIC data type, the scale is defined, and for all other data types, it is not defined.</p> <p>This information is returned in the record field of SQL_DESC_SCALE of IRD.</p>
SQL_DESC_SCHEMA_NAME (ODBC 2.0)	CharacterAttributePtr	<p>It is the schema of a table containing a column.</p>
SQL_DESC_SEARCH		<ul style="list-style-type: none"> <li>SQL_PRED_NONE: The column can not used in WHERE clause. (It is as same as SQL_UNSEARCHABLE of ODBC 2.x.)</li> <li>SQL_PRED_CHAR: The column can be used in WHERE clause but only</li> </ul>

FieldIdentifier	Information return	Description
CHABLE (ODBC 1.0)	NumericAttribute Ptr	with the LIKE predicate. (It is as same as SQL_LIKE_ONLY of ODBC 2.x.)  <ul style="list-style-type: none"> <li>SQL_PRED_BASIC: Any comparison operator except LIKE can be used in WHERE clause. (It is as same as SQL_EXCEPT_LIKE of ODBC 2.x.)</li> <li>SQL_PRED_SEARCHABLE: The column can be used in WHERE clause to gether with any comparison operator.</li> </ul>
SQL_DESC_TABLE_NAME (ODBC 2.0)	CharacterAttribute ePtr	It is the name of table including the column. If the tabe name is unknown, an empty string is returned.
SQL_DESC_TYPE (ODBC 3.0)	NumericAttribute Ptr	It is the numeric value to specify the SQL data type. For datetime or interval data type, the verbose data type such as SQL_DATE TIME or SQL_INTERVAL is returned.  This information is returned in the record field of SQL_DESC_TYPE of IRD.
SQL_DESC_TYPE_NAME (ODBC 1.0)	CharacterAttribute ePtr	It is the data type name which is dependent on the data source. (e.g. "CHARACTER", "CHARACTER VARYING", "CHARACTER LONG VARYING")
SQL_DESC_UNNAMED (ODBC 3.0)	NumericAttribute Ptr	It is SQL_NAMED or SQL_UNNAMED. If the column alias or column name is included in the field of SQL_DESC_NAME of IRD, SQL_NAMED is returned, and if there is not a column name or alias, SQL_UNNAME is returned.  This information is returned in the record field of SQL_DESC_UNNAMED of IRD.
SQL_DESC_UNSIGNED (ODBC 1.0)	NumericAttribute Ptr	<ul style="list-style-type: none"> <li>SQL_TRUE: The column is neither an unsigned nor is a number.</li> <li>SQL_FALSE: The column is a signed.</li> </ul>
SQL_DESC_UPDATABLE (ODBC 1.0)	NumericAttribute Ptr	The column can have the value of SQL_ATTR_READONLY, SQL_ATTR_WRITE, SQL_ATTR_READWRITE_UNKNOWN.

# SQLColAttributes

## Conformance

Introduced version: ODBC 1.0

Standards compliance: It is not available.

## Overview

SQLColAttributes function in ODBC 2.0 was replaced with SQLColAttribute function in ODBC 3.x.

For more information, refer to [SQLColAttribute](#).



# SQLColumnPrivileges

## Conformance

Introduced version: ODBC 1.0

Standards compliance: ODBC

## Overview

SQLColumnPrivileges returns a list of columns and related privileges for the specified table as a result set.

## Syntax

```
SQLRETURN SQLColumnPrivileges(  
    SQLHSTMT      StatementHandle,  
    SQLCHAR *     CatalogName,  
    SQLSMALLINT   NameLength1,  
    SQLCHAR *     SchemaName,  
    SQLSMALLINT   NameLength2,  
    SQLCHAR *     TableName,  
    SQLSMALLINT   NameLength3,  
    SQLCHAR *     ColumnName,  
    SQLSMALLINT   NameLength4);
```

## Arguments

### StatementHandle

[Input] It is the statement handle.

### CatalogName

[Input] It is the catalog name. CatalogName can not include the string search pattern.

If the SQL\_ATTR\_METADATA\_ID statement attribute is set to SQL\_TRUE, CatalogName is treated as a case-insensitive identifier. If it is set to SQL\_FALSE, CatalogName is case-sensitive, and it is an ordinary argument literally processed.

### NameLength1

[Input] It is the length of \*CatalogName.

**SchemaName**

[Input] It is the schema name. SchemaName can not include the string search pattern.

If the SQL\_ATTR\_METADATA\_ID statement attribute is set to SQL\_TRUE, SchemaName is treated as a case-insensitive identifier. If it is set to SQL\_FALSE, SchemaName is case-sensitive, and it is an ordinary argument literally processed.

**NameLength2**

[Input] It is the length of \*SchemaName.

**TableName**

[Input] It is the table name. This argument can not be a null pointer. TableName can not include the string search pattern.

If the SQL\_ATTR\_METADATA\_ID statement attribute is set to SQL\_TRUE, TableName is treated as a case-insensitive identifier. If it is set to SQL\_FALSE, TableName is case-sensitive, and it is an ordinary argument literally processed.

**NameLength3**

[Input] It is the length of \*TableName.

**ColumnName**

[Input] It is the string search pattern for the column name.

If the SQL\_ATTR\_METADATA\_ID statement attribute is set to SQL\_TRUE, ColumnName is treated as a case-insensitive identifier. If it is set to SQL\_FALSE, ColumnName is case-sensitive, and it is a pattern value literally processed.

**NameLength4**

[Input] It is the length of \*ColumnName.

**Returns**

SQL\_SUCCESS, SQL\_SUCCESS\_WITH\_INFO, SQL\_STILL\_EXECUTING, SQL\_ERROR, SQL\_INVALID\_HANDLE

**Diagnosis**

SQLSTATE	Error	Description
08S01	Communication link failure	Before the function processing is completed, the connection between the driver and the data source is failed.
24000	Invalid cursor state	SQLFetch, SQLFetchScroll are called and a cursor is open.
HY000	General error	It is an error without specific SQLSTATE.
HY001	Memory allocation error	It is a memory allocation error.
HY009	Invalid use of null pointer	TableName argument is the null pointer.  The attribute value of SQL_ATTR_METADATA_ID is SQL_TRUE state

SQLSTATE	Error	Description
		ment, and SchemaName or ColumnName is the null pointer.
HY010	Function sequence error	After calling SQLExecute, SQLExecDirect, then SQL_NEED_DATA is returned, and the function is called before sending all data-at-execution variables.
HY090	Invalid string or buffer length	A name length argument value is smaller than 0 but it is not SQL_NTS.
HYT00	Timeout expired	Before downloading the entire result set from the data source, the query timeout expired. The timeout can be set through SQL_ATTR_QUERY_TIMEOUT of SQLSetStmtAttr.

## Description

SQLColumnPrivileges returns the standard result set aligned as TABLE\_CAT, TABLE\_SCHEM, TABLE\_NAME, COLUMN\_NAME, PRIVILEGE.

The following table describes the columns in the result set.

Column name	Column number	Data type	Description
TABLE_CAT (ODBC 1.0)	1	VARCHAR	It is the catalog identifier.
TABLE_SCHEM (ODBC 1.0)	2	VARCHAR	It is the schema identifier.
TABLE_NAME (ODBC 1.0)	3	VARCHAR not NULL	It is the table identifier.
COLUMN_NAME (ODBC 1.0)	4	VARCHAR not NULL	It is the column name. It returns an empty string for a column which does not have a name.
GRANTOR (ODBC 1.0)	5	VARCHAR	It is the grantor name.
GRANTEE (ODBC 1.0)	6	VARCHAR not NULL	It is the grantee name.
PRIVILEGE (ODBC 1.0)	7	VARCHAR not NULL	It is the column privilege identifier. It can be one of the followings. <ul style="list-style-type: none"> <li>• SELECT: The grantee is allowed to retrieve the column data.</li> <li>• INSERT: The grantee is allowed to insert the data to the column of the associated table.</li> <li>• UPDATE: The grantee is allowed to update the column data.</li> <li>• REFERENCES: The grantee is allowed to reference the column in the constraints (e.g. unique, referential, table check constraint).</li> </ul>

Column name	Column number	Data type	Description
IS_GRANTABLE (ODBC 1.0)	8	VARCHAR	It checks whether the grantee can grant the privilege to other user, and it is specified as "YES", "NO".

# SQLColumns

## Conformance

Introduced version: ODBC 1.0

Standards compliance: Open Group

## Overview

SQLColumns returns a list of column names in the specified table as a result set.

## Syntax

```
SQLRETURN SQLColumns(
    SQLHSTMT      StatementHandle,
    SQLCHAR *     CatalogName,
    SQLSMALLINT   NameLength1,
    SQLCHAR *     SchemaName,
    SQLSMALLINT   NameLength2,
    SQLCHAR *     TableName,
    SQLSMALLINT   NameLength3,
    SQLCHAR *     ColumnName,
    SQLSMALLINT   NameLength4);
```

## Arguments

### StatementHandle

[Input] It is the statement handle.

### CatalogName

[Input] It is the catalog name. CatalogName can not include the string search pattern.

If the SQL\_ATTR\_METADATA\_ID statement attribute is set to SQL\_TRUE, CatalogName is treated as a case-insensitive identifier. If it is set to SQL\_FALSE, CatalogName is case-sensitive, and it is an ordinary argument literally processed.

### NameLength1

[Input] It is the length of \*CatalogName

### SchemaName

[Input] It is the string search pattern for the schema name.

If the `SQL_ATTR_METADATA_ID` statement attribute is set to `SQL_TRUE`, `SchemaName` is treated as a case-insensitive identifier. If it is set to `SQL_FALSE`, `SchemaName` is case-sensitive, and it is an ordinary argument literally processed.

### NameLength2

[Input] It is the length of `*SchemaName`.

### TableName

[Input] It is the string search pattern for the table name.

If the `SQL_ATTR_METADATA_ID` statement attribute is set to `SQL_TRUE`, `TableName` is treated as a case-insensitive identifier. If it is set to `SQL_FALSE`, `TableName` is case-sensitive, and it is an ordinary argument literally processed.

### NameLength3

[Input] It is the length of `*TableName`.

### ColumnName

[Input] It is the string search pattern for the column name.

If the `SQL_ATTR_METADATA_ID` statement attribute is set to `SQL_TRUE`, `ColumnName` is treated as a case-insensitive identifier. If it is set to `SQL_FALSE`, `ColumnName` is case-sensitive, and it is a pattern value literally processed.

### NameLength4

[Input] It is the length of `*ColumnName`.

## Returns

`SQL_SUCCESS`, `SQL_SUCCESS_WITH_INFO`, `SQL_STILL_EXECUTING`, `SQL_ERROR`, `SQL_INVALID_HANDLE`

## Diagnosis

SQLSTATE	Error	Description
08S01	Communication link failure	Before the function processing is completed, the connection between the driver and the data source is failed.
24000	Invalid cursor state	<code>SQLFetch</code> , <code>SQLFetchScroll</code> are called and a cursor is open.
HY000	General error	It is an error without any specific SQLSTATE.
HY001	Memory allocation error	It is a memory allocation error.
HY009	Invalid use of null pointer	<code>TableName</code> argument is a null pointer. The attribute value of <code>SQL_ATTR_METADATA_ID</code> statement is <code>SQL_TRUE</code> , <code>SchemaName</code> or <code>ColumnName</code> is a null pointer.
HY010	Function sequence error	After calling <code>SQLExecute</code> , <code>SQLExecDirect</code> , then <code>SQL_NEED_DATA</code> is returned, and the function is called before sending all data-at-execution variables.

SQLSTATE	Error	Description
HY090	Invalid string or buffer length	A name length argument value is smaller than 0 but it is not SQL_NTS.
HYT00	Timeout expired	Before downloading the entire result set from the data source, the query timeout expired. The timeout can be set through SQL_ATTR_QUERY_TIMEOUT of SQLSetStmtAttr.

## Description

This function is generally used prior to the execution of statement which retrieves information about the columns of the table or tables in the catalog of the data source. SQLColumns can be used to retrieve all data types returned by SQLTables. By contrast, SQLColAttribute and SQLDescribeCol describe the columns in the result set, and SQLNumResultCols returns the number of columns in the result set.

SQLColumns returns the standard result set sorted as TABLE\_CAT, TABLE\_SCHEM, TABLE\_NAME, ORDINAL\_POSITION.

The following table describes the columns in the result set.

Column name	Column number	Data type	Description
TABLE_CAT (ODBC 1.0)	1	VARCHAR	It is the catalog name.
TABLE_SCHEM (ODBC 1.0)	2	VARCHAR	It is the schema name.
TABLE_NAME (ODBC 1.0)	3	VARCHAR not NULL	It is the table name.
COLUMN_NAME (ODBC 1.0)	4	VARCHAR not NULL	It is the column name. It returns an empty string for a column which does not have a name.
DATA_TYPE (ODBC 1.0)	5	SMALLINT not NULL	It is SQL data type. For datetime and interval data types, the column returns the concise data type like SQL_TYPE_DATE, SQL_INTERVAL_YEAR_TO_MONTH.
TYPE_NAME (ODBC 1.0)	6	VARCHAR not NULL	It is the data type name dependent on the data source. (e.g. "CHARACTER", "CHARACTER VARYING", "CHARACTER LONG VARYING")
COLUMN_SIZE (ODBC 1.0)	7	INTEGER	If DATA_TYPE is SQL_CHAR or SQL_VARCHAR, the column includes the maximum number of characters up to length of the column. If it is a datetime data column, it is the number of characters needed for converting the value to the character. If it is a numeric data type, it is the total

Column name	Column number	Data type	Description
0)			number of digits of the column NUM_PREC_RADIX or the number of bits allowed for the column. If it is an interval data type, it is the number of characters needed to be represented by the interval leading precision.
BUFFER_LENGTH (ODBC 1.0)	8	INTEGER	If SQL_C_DEFAULT is specified, it is the byte length of the data to be transmitted to SQLGetData, SQLFetch, SQLFetchScroll.
DECIMAL_DIGITS (ODBC 1.0)	9	SMALLINT	For a positive number, it is the number of significant digits on the right of the decimal point. For a negative number, it is the number of significant digits on the left of the decimal point. For SQL_TYPE_TIME and SQL_TYPE_TIMESTAMP, this column is the number of digits of fractional seconds. For interval data type that contains the second, it is the number of digits right of the decimal point (fractional seconds). The data type that DECIMAL DIGITS can not be applied, returns NULL.
NUM_PREC_RADIX (ODBC 1.0)	10	SMALLINT	For the numeric data type, it is 2 or 10. For 2, COLUMN_SIZE and DECIMAL_DIGITS are the number of bits allowed in the column. For 10, COLUMN_SIZE and DECIMAL_DIGITS are the number of digits allowed in the column.  The data type that NUM_PREC_RADIX can not be applied, returns NULL.
NULLABLE (ODBC 1.0)	11	SMALLINT not NULL	<ul style="list-style-type: none"> <li>SQL_NO_NULLS: The column can not have NULL value.</li> <li>SQL_NULLABLE: The column can have NULL value.</li> <li>SQL_NULLABLE_UNKNOWN: It is unknown whether the column is allowed to have NULL value.</li> </ul>
REMARKS (ODBC 1.0)	12	VARCHAR	It is the description on the column.
COLUMN_DEFAULT (ODBC 3.0)	13	VARCHAR	It is the default value of column. If the value is enclosed by the quote, the column should be interpreted as a string.
SQL_DATA_TYPE (ODBC 3.0)	14	SMALLINT not NULL	It is the SQL data type of the record field of SQL_DESC_TYPE of IRD. The column is the same as DATA TYPE except the datetime and interval data types. For datetime and interval data types, the column returns the nonconcise data type like SQL_DATE, SQL_INTERVAL, and the specific data type is determined using SQL_DATETIME_SUB column.
SQL_DATETIME_SUB (ODBC 3.0)	15	SMALLINT	It is the sub type code of datetime and interval data types. Other data types return NULL.
CHAR_OCTET_LENGTH (ODBC 3.0)	16	INTEGER	It is the maximum length in bytes of characters or binary data type column. Other data types return NULL.
ORDINAL_P			



Column name	Column number	Data type	Description
POSITION (ODBC 3.0)	17	INTEGER not NULL	It is the column position in the table.
IS_NULLABLE (ODBC 3.0)	18	VARCHAR	<ul style="list-style-type: none"><li>"NO": The column can not contain NULL.</li><li>"YES": The column can contain NULL.</li></ul> If it is unknown whether NULL is allowed, It returns a zero-length string.

# SQLConnect

## Conformance

Introduced version: ODBC 1.0

Standards compliance: ISO 92

## Overview

SQLConnect sets a connection between the driver and the data source. The connection handle refers to a handle of information about the connection including status, transaction status and error information.

## Syntax

```
SQLRETURN SQLConnect(  
    SQLHDBC      ConnectionHandle,  
    SQLCHAR *    ServerName,  
    SQLSMALLINT  NameLength1,  
    SQLCHAR *    UserName,  
    SQLSMALLINT  NameLength2,  
    SQLCHAR *    Authentication,  
    SQLSMALLINT  NameLength3);
```

## Arguments

### ConnectionHandle

[Input] It is the connection handle.

### ServerName

[Input] It is the data source name.

### NameLength1

[Input] It is the length of \*ServerName.

### UserName

[Input] It is the user identifier.

### NameLength2

[Input] It is the length of \*UserName.

## Authentication

[Input] It is the authentication string (typically password).

## NameLength3

[Input] It is the length of \*Authentication.

## Returns

SQL\_SUCCESS, SQL\_SUCCESS\_WITH\_INFO, SQL\_ERROR, SQL\_INVALID\_HANDLE, SQL\_STILL\_EXECUTING

## Diagnosis

SQLSTATE	Error	Description
08001	Client unable to establish connection	The driver can not set a connection with a data source.
08002	Connection name in use	The specified ConnectionHandle is already connected with the data source.
08004	Server rejected the connection	In the state of the setting limits, the data source rejects to establish the connection.
08S01	Communication link failure	Before the function processing is completed, the connection between the driver and the data source is failed.
28000	Invalid authorization specification	The argument value of UserName or Authentication is not correct.
HY000	General error	It is an error without any specific SQLSTATE.
HY001	Memory allocation error	It is a memory allocation error.
HY090	Invalid string or buffer length	The value of NameLength1, NameLength2 or NameLength3 is smaller than 0, but it is not SQL_NTS.
HYT00	Timeout expired	Before connecting to the data source, Login timeout expired. The timeout can be set through SQL_ATTR_LOGIN_TIMEOUT of SQLSetConnectAttr.

## Description

The driver searches for the user DSN information in an order of \$HOME/.odbc.ini file and /home/.odbc.ini file which are files set in \$ODBCINI environment variable. If the DSN which was input in the user DSN does not exist, the driver searches for the DSN information in an order of \$ODBCSYSINI/odbc.ini file, /etc/odbc.ini file which is system DSN.

# SQLCopyDesc

It is not supported.

## Conformance

Introduced version: ODBC 3.0

Standards compliance: ISO 92

## Overview

SQLCopyDesc copies the descriptor information from one descriptor handle to another descriptor handle.

## Syntax

```
SQLRETURN SQLCopyDesc(  
    SQLHDESC    SourceDescHandle,  
    SQLHDESC    TargetDescHandle);
```

# SQLDescribeCol

## Conformance

Introduced version: ODBC 1.0

Standards compliance: ISO 92

## Overview

SQLDescribeCol returns a column name, type, column size, decimal place, information about null permit in the result set column. The information can be used in the fields of IRD.

## Syntax

```
SQLRETURN SQLDescribeCol(  
    SQLHSTMT      StatementHandle,  
    SQLUSMALLINT  ColumnNumber,  
    SQLCHAR *     ColumnName,  
    SQLSMALLINT   BufferLength,  
    SQLSMALLINT * NameLengthPtr,  
    SQLSMALLINT * DataTypePtr,  
    SQLULEN *     ColumnSizePtr,  
    SQLSMALLINT * DecimalDigitsPtr,  
    SQLSMALLINT * NullablePtr);
```

## Arguments

### StatementHandle

[Input] It is the statement handle.

### ColumnNumber

[Input] It is the column number in the result set which is started from 1 and increased sequentially.

### ColumnName

[Output] It is the buffer pointer which is terminated by a null and returns the column name. This value can be read in SQL\_DESC\_NAME field of IRD. If the column name does not exist or the column name is unknown, the driver returns an empty string.

If ColumnName is null, NameLengthPtr returns the total number of bytes returnable. (excluding null-termination character)

**BufferLength**

[Input] It is the length of \*ColumnName.

**NameLengthPtr**

[Output] It is the buffer pointer which returns the total number of bytes returnable to \*ColumnName (excluding the null-termination character). If the returnable length is equal to or bigger than BufferLength, \*ColumnName is truncated to the length of BufferLength minus null.

**DataTypePtr**

[Output] It is the buffer pointer which returns the SQL type of a column. The value can be read in SQL\_DESC\_CONCISE\_TYPE of IRD.

**ColumnSizePtr**

[Output] It is the buffer pointer which returns the column size of the data source.

**DecimalDigitsPtr**

[Output] It is the buffer pointer which returns the decimal place of the data source.

**NullablePtr**

[Output] It is the buffer pointer which returns whether the column allows for null. The value can be read in SQL\_DESC\_NULLABLE field of IRD. It is one of the followings.

- SQL\_NO\_NULLS: The column does not allow NULL.
- SQL\_NULLABLE: The column allows NULL.
- SQL\_NULLABLE\_UNKNOWN: The driver can not determine whether the column allows NULL.

**Returns**

SQL\_SUCCESS, SQL\_SUCCESS\_WITH\_INFO, SQL\_STILL\_EXECUTING, SQL\_ERROR, SQL\_INVALID\_HANDLE

**Diagnosis**

SQLSTATE	Error	Description
01004	String data, right truncated	*ColumnName is not large enough to return the entire column name, so the column name is truncated. The column length not truncated is returned in *NameLengthPtr. (The function returns SQL_SUCCESS_WITH_INFO.)
07005	Prepared statement not a cursor-specification	The statement does not return a result set, so there is not a column to be explained.
07009	Invalid descriptor index	The value of ColumnNumber argument is bigger than the number of columns in the result set.
08S01	Communication link failure	Before the function processing is completed, the connection between the driver and the data source is failed.

SQLSTATE	Error	Description
HY000	General error	It is an error without any specific SQLSTATE.
HY001	Memory allocation failure	It is a memory allocation error.
HY010	Function sequence error	After calling SQLExecute, SQLExecDirect, then SQL_NEED_DATA is returned, the function is called before sending all data-at-execution variables.
HY090	Invalid string or buffer length	The value of BufferLength argument is smaller than 0.

## Description

Generally, the application calls SQLDescribeCol before or after calling SQLExecute related after calling SQL Prepare. Also, the application may call SQLDescribeCol after calling SQLExecDirect.

# SQLDescribeParam

## Conformance

Introduced version: ODBC 1.0

Standards compliance: ODBC

## Overview

SQLDescribeParam returns the description of a parameter marker related to a prepared SQL statement. This information can be used in the fields of the IPD.

## Syntax

```
SQLRETURN SQLDescribeParam(  
    SQLHSTMT      StatementHandle,  
    SQLUSMALLINT  ParameterNumber,  
    SQLSMALLINT *  DataTypePtr,  
    SQLULEN *     ParameterSizePtr,  
    SQLSMALLINT *  DecimalDigitsPtr,  
    SQLSMALLINT *  NullablePtr);
```

## Arguments

### StatementHandle

[Input] It is the statement handle.

### ParameterNumber

[Input] It is the parameter marker number which is started from 1 and increased sequentially.

### DataTypePtr

[Output] It is the buffer pointer which returns the SQL type of parameter. The value can be read in the record field of SQL\_DESC\_CONCISE\_TYPE of IPD.

### ParameterSizePtr

[Output] It is the buffer pointer which returns the size of column or expression for the parameter marker.

### DecimalDigitsPtr

[Output] It is the buffer pointer which returns the decimal places of column or expression for the parameter marker.



## NullablePtr

[Output] It is the buffer pointer which returns whether the parameter allows for null. The value can be read in SQL\_DESC\_NULLABLE of IPD. The value is one of the followings.

- SQL\_NO\_NULLS: The parameter does not allow NULL.
- SQL\_NULLABLE: The parameter allows NULL.
- SQL\_NULLABLE\_UNKNOWN: The driver can not determine whether the parameter allows NULL.

## Returns

SQL\_SUCCESS, SQL\_SUCCESS\_WITH\_INFO, SQL\_STILL\_EXECUTING, SQL\_ERROR, SQL\_INVALID\_HANDLE

## Diagnosis

SQLSTATE	Error	Description
07009	Invalid descriptor index	The value of ParameterNumber argument is smaller than 1. The value of ParameterNumber argument is bigger than the number of parameters of the related SQL statement.
08S01	Communication link failure	Before the function processing is completed, the connection between the driver and the data source is failed.
HY000	General error	It is an error without any specific SQLSTATE.
HY001	Memory allocation error	It is a memory allocation error.
HY010	Function sequence error	The function is called before SQLPrepare or SQLExecDirect. After calling SQLExecute, SQLExecDirect, then SQL_NEED_DATA is returned, and the function is called before sending all data-at-execution variables.

## Description

SQL\_VARCHAR should be returned to \*DataTypePtr, 4000 should be returned to \*ParameterSizePtr, 0 should be returned to \*DecimalDigitsPtr, and SQL\_NULLABLE should be returned to \*NullablePtr because the driver can not provide the exact information of the parameter using the prepared SQL.

# SQLDisconnect

## Conformance

Introduced version: ODBC 1.0

Standards compliance: ISO 92

## Overview

SQLDisconnect closes the connection related to the specific connection handle.

## Syntax

```
SQLRETURN SQLDisconnect(  
    SQLHDBC    ConnectionHandle);
```

## Arguments

### ConnectionHandle

[Input] It is the connection handle.

## Returns

SQL\_SUCCESS, SQL\_SUCCESS\_WITH\_INFO, SQL\_ERROR, SQL\_INVALID\_HANDLE, SQL\_STILL\_EXECUTING

## Diagnosis

SQLSTATE	Error	Description
08003	Connection not open	The connection of ConnectionHandle argument is not open.
25000	Invalid transaction state	The transaction is in progress on the connection of ConnectionHandle argument. The transaction remains active.
HY000	General error	It is an error without any specific SQLSTATE.
HY001	Memory allocation error	It is a memory allocation error.

## Description

If the application calls `SQLDisconnect` to the connection handle with an incomplete transaction, the driver returns `SQLSTATE 25000` (Invalid transaction state), the transaction is not changed, and the connection is open. The incomplete transaction is a transaction which is not committed or rolled back by using `SQLEndTran`.

If the application calls `SQLDisconnect` before disconnecting all statements, the driver is disconnected from the data source, then deletes all statements and the descriptor explicitly assigned to the connection handle.

# SQLDriverConnect

## Conformance

Introduced version: ODBC 1.0

Standards compliance: ODBC

## Overview

SQLDriverConnect can replace SQLConnect, and it supports the data source which requires more information of connection than three arguments of SQLConnect.

SQLDriverConnect establishes the connection by using the connection string which includes other information required by the data source name, one or more users, one or more passwords and the data sources.

When the connection is established, SQLDriverConnect returns the completed connection string. The application can use this string when requesting the next connection.

## Syntax

```
SQLRETURN SQLDriverConnect(
    SQLHDBC          ConnectionHandle,
    SQLHWND          WindowHandle,
    SQLCHAR *        InConnectionString,
    SQLSMALLINT      StringLength1,
    SQLCHAR *        OutConnectionString,
    SQLSMALLINT      BufferLength,
    SQLSMALLINT *    StringLength2Ptr,
    SQLUSMALLINT     DriverCompletion);
```

## Arguments

### ConnectionHandle

[Input] It is the connection handle.

### WindowHandle

[Input] It is the window handle. The application passes the superordinate window handle or a null pointer, and for the null pointer, SQLDriverConnect does not display the dialog box.

**InConnectionString**

[Input] It is the full connection string, partial connection string or empty string.

**StringLength1**

[Input] It is the length of \*InConnectionString.

**OutConnectionString**

[Output] It is the buffer pointer of the completed connection string. If it is successfully connected to the target data source, the buffer contains the completed connection string. The application should allocate a buffer with at least 1,024 characters.

If OutConnectionString is NULL, the total number of returnable characters are returned in StringLength2Ptr (excluding null termination character).

**BufferLength**

[Input] It is the length of \*OutConnectionString

**StringLength2Ptr**

[Output] It is the buffer pointer which returns the total number of returnable characters to \*OutConnectionString (excluding null termination character). If the returnable length is equal to or bigger than BufferLength, \*OutConnectionString is truncated to the length of BufferLength minus a null-termination character.

**DriverCompletion**

[Input] It is a flag that indicates whether the driver has to request more information. the value is one of SQL\_DRIVER\_PROMPT, SQL\_DRIVER\_COMPLETE, SQL\_DRIVER\_COMPLETE\_REQUIRED, SQL\_DRIVER\_NOPROMPT.

**Returns**

SQL\_SUCCESS, SQL\_SUCCESS\_WITH\_INFO, SQL\_NO\_DATA, SQL\_ERROR, SQL\_INVALID\_HANDLE, SQL\_S  
TILL\_EXECUTING

**Diagnosis**

SQLSTATE	Error	Description
01004	String data, right truncated	*OutConnectionString buffer is not large enough to return the entire connection string, so the connection string is truncated. The connection string length not truncated is returned in *StringLength2Ptr. (The function returns SQL_SUCCESS_WITH_INFO.)
08001	Client unable to establish connection	The driver can not establish a connection with the data source.
08002	Connection name in use	The specified ConnectionHandle is already connected with a data source.

SQLSTATE	Error	Description
08004	Server rejected the connection	In the state of the limits of the setting value, the data source rejects to establish the connection.
08S01	Communication link failure	Before the function processing is completed, the connection between the driver and the data source is failed.
28000	Invalid authorization specification	The user identifier and authentication string of the connection string are not correct.
HY000	General error	It is an error without any specific SQLSTATE.
HY001	Memory allocation error	It is a memory allocation error.
HY090	Invalid string or buffer length	The value of StringLength1 argument is smaller than 0, but it is not SQL_NTS. The value of BufferLength argument is smaller than 0.
HY110	Invalid driver completion	The value of DriverCompletion argument is not one of SQL_DRIVER_PROMPT, SQL_DRIVER_COMPLETE, SQL_DRIVER_COMPLETE_REQUIRED, SQL_DRIVER_NOPROMPT.
HYC00	Optional feature not implemented	The driver does not support the ODBC operation which is required by the application.
HYT00	Timeout expired	Before connecting to the data source, login timeout is expired. The timeout can be set through SQL_ATTR_LOGIN_TIMEOUT of SQLSetConnectAttr.

## Description

The syntax of connection string is as follows.

```
connection-string ::= empty-string[;] | attribute[;] | attribute; connection-string
empty-string ::= attribute ::= attribute-keyword=attribute-value | DRIVER={{attribute-value}}
attribute-keyword ::= DSN | PROTOCOL | CS_MODE | HOST | PORT | UID | PWD | ALTERNATE_SERVERS |
FAILOVER_TYPE | FAILOVER_GANULARITY | DATE_FORMAT | TIME_FORMAT | TIME_WITH_TIME_ZONE_FORMAT
| TIMESTAMP_FORMAT | TIMESTAMP_WITH_TIME_ZONE_FORMAT | CHAR_LENGTH_UNITS | CONN_NAME
attribute-value ::= character-string
```

character-string is zero or more characters. attribute-keyword is case-insensitive, and attribute-value may be case-sensitive. The value of DSN keyword does not consist only of white spaces.

The following table describes attribute-keywords.

Keyword	Description
DSN	It is the data source name.
PROTOCOL	It is the connection type (DA, TCP).
CS_MODE	It sets whether to connect with dedicated mode or shared mode. If the setting is not used, the mode is determined depending on the configuration (DE

Keyword	Description
	FAULT_CS_MODE) of listener.
HOST	It is the host IP address.
PORT	It is the connection port number.
TCP_NODELAY	It is a socket TCP_NODELAY option.
UID	It is the user ID.
PWD	It is the password for user ID. If password does not exist, it is an empty string (PWD=;).
ALTERNATE_SERVERS	It is a server list which attempts a connection when the failover occurs, and each server is separated with comma (,). If failover is not used, ALTERNATE_SERVERS is not set.
FAILOVER_TYPE	<ul style="list-style-type: none"> <li>• CONNECTION: When the connection fails, it is connected to ALTERNATE_SERVERS.</li> <li>• SESSION: When the connection fails or the connection is disconnected during operating the statement, it is connected to ALTERNATE_SERVERS and the statement is restored. The statement is executed after the failover if the connection is disconnected when a transaction is not in progress.</li> </ul>
FAILOVER_GRANULARITY	<ul style="list-style-type: none"> <li>• 0: Failover proceeds even when an error occurs during the failover.</li> <li>• 1: Failover fails when an error occurs except for SQLExecute(), SQLExecDirect() during the failover.</li> <li>• 2: Failover fails when an error occurs during the failover.</li> </ul>
DATE_FORMAT	It is the DATE type format string.
TIME_FORMAT	It is the TIME type format string.
TIME_WITH_TIME_ZONE_FORMAT	It is the TIME WITH TIME ZONE type format string.
TIMESTAMP_FORMAT	It is the TIMESTAMP type format string.
TIMESTAMP_WITH_TIME_ZONE_FORMAT	It is the TIMESTAMP WITH TIME ZONE type format string.
CHAR_LENGTH_UNITS	If ParameterType is one of SQL_CHAR or SQL_VARCHAR in SQLBindParameter(), it is a unit of ColumnSize. <ul style="list-style-type: none"> <li>• BYTE, OCTETS: Bytes unit</li> <li>• CHAR, CHARACTERS: Characters unit</li> </ul>
CONN_NAME	It is the connection name used in XA. The specified name is valid only in embedded SQL program, and is ignored in other programs.

# SQLEndTran

## Conformance

Introduced version: ODBC 3.0

Standards compliance: ISO 92

## Overview

SQLEndTran requests a commit or rollback for active transactions of all statements related to the connection.

## Syntax

```
SQLRETURN SQLEndTran(
    SQLSMALLINT  HandleType,
    SQLHANDLE     Handle,
    SQLSMALLINT  CompletionType);
```

## Arguments

### HandleType

[Input] It is the handle identifier. If it is an environment handle it is SQL\_HANDLE\_ENV, and if it is a connection handle it is SQL\_HANDLE\_DBC.

### Handle

[Input] It is the handle of HandleType which indicates the transaction range.

### CompletionType

[Input] It is SQL\_COMMIT or SQL\_ROLLBACK.

## Returns

SQL\_SUCCESS, SQL\_SUCCESS\_WITH\_INFO, SQL\_ERROR, SQL\_INVALID\_HANDLE, SQL\_STILL\_EXECUTING

## Diagnosis

SQLSTATE	Error	Description
08003	Connection not o	HandleType is SQL_HANDLE_DBC, and a handle is not connected.



SQLSTATE	Error	Description
	pen	
HY000	General error	It is an error without any specific SQLSTATE.
HY001	Memory allocation error	It is a memory allocation error.
HY010	Function sequence error	After calling SQLExecute, SQLExecDirect, then SQL_NEED_DATA is returned, and the function is called before sending all data-at-execution variables.
HY012	Invalid transaction operation code	The value of CompletionType argument is not one of SQL_COMMIT or SQL_ROLLBACK.
HY092	Invalid attribute/option identifier	The value of HandleType argument is not one of SQL_HANDLE_ENV or SQL_HANDLE_DBC.

## Description

If CompletionType is SQL\_COMMIT, then SQLEndTran requests the commit for all active transactions of statements related to the connection. If CompletionType is SQL\_ROLLBACK, then SQLEndTran requests the rollback for all active transactions of statements related to the connection. If active transaction does not exist, SQLEndTran returns SQL\_SUCCESS without affecting the data source.

If the driver is a manual commit mode(The SQL\_ATTR\_AUTOCOMMIT attribute is set to SQL\_AUTOCOMMIT\_OFF by calling SQLSetConnectAttr.) and the SQL statement is executed for the current data source, a new transaction implicitly starts.

SQLEndTran does not affect the open cursor related to the connection when committing. The cursor remains on the row pointed before calling SQLEndTran.

SQLEndTran closes all open cursors on all statements when rolling back. SQLEndTran sets the statement to the ready state, and the application does not call SQLPrepare, but it calls SQLExecute.

If an active transaction does not exist, SQLEndTran returns SQL\_SUCCESS.

If the driver is an auto commit mode, SQLEndTran always returns SQL\_SUCCESS regardless of CompletionType.

# SQLException

## Conformance

Introduced version: ODBC 1.0

Standards compliance: It is not available.

## Overview

SQLException returns an error or status information.

# SQLExecDirect

## Conformance

Introduced version: ODBC 1.0

Standards compliance: ISO 92

## Overview

If `SQLExecDirect` has the parameter in the statement, it executes the statement by using the current value of parameter marker. `SQLExecDirect` is the fastest way of when the statement is executed only once.

## Syntax

```
SQLRETURN SQLExecDirect(  
    SQLHSTMT    StatementHandle,  
    SQLCHAR *   StatementText,  
    SQLINTEGER  TextLength);
```

## Arguments

### StatementHandle

[Input] It is the statement handle.

### StatementText

[Input] It is the executed SQL statement.

### TextLength

[Input] It is the length of `*StatementText`.

## Returns

`SQL_SUCCESS`, `SQL_SUCCESS_WITH_INFO`, `SQL_NEED_DATA`, `SQL_STILL_EXECUTING`, `SQL_ERROR`, `SQL_NO_DATA`, `SQL_INVALID_HANDLE`, `SQL_PARAM_DATA_AVAILABLE`

## Diagnosis

SQLSTATE	Error	Description
01004	String data, right truncated	The string or binary data returned to the input/output or output parameters are truncated. The right part of the string is truncated. (The function returns SQL_SUCCESS_WITH_INFO.)
01S02	Option value changed	<p>It is temporarily replaced with a similar value because the attribute value of the specified statement is not suitable for executing the operation. (SQLGetStmtAttr can be called to see which value is temporarily changed.) The replaced value is valid until the cursor is closed, and it is changed to the previous value when the cursor is closed.</p> <p>The statement attributes which can be changed are as follows. SQL_ATTR_CONCURRENCY, SQL_ATTR_CURSOR_TYPE, SQL_ATTR_KEYSET_SIZE, SQL_ATTR_MAX_LENGTH, SQL_ATTR_MAX_ROWS, SQL_ATTR_QUERY_TIMEOUT, SQL_ATTR_SIMULATE_CURSOR.</p> <p>(The function returns SQL_SUCCESS_WITH_INFO.)</p>
07006	Restricted data type attribute violation	<p>The data value identified by ValueType argument of SQLBindParameter can not be converted to the data type identified by ParameterType argument of SQLBindParameter.</p> <p>The data value returned to the parameter of SQL_PARAM_INPUT_OUTPUT or SQL_PARAM_OUTPUT can not be converted to the data type identified by ValueType argument of SQLBindParameter.</p> <p>(If one or more rows are successfully returned, the function returns SQL_SUCCESS_WITH_INFO.)</p>
07007	Restricted parameter value violation	The parameter type is SQL_PARAM_INPUT_OUTPUT, and *StrLen_or_IndPtr of SQLBindParameter is not one of SQL_NULL_DATA, SQL_DEFAULT_PARAMETER, SQL_LEN_DATA_AT_EXEC(len), or SQL_DATA_AT_EXEC.
08S01	Communication link failure	Before the function processing is completed, the connection between the driver and the data source is failed.
22001	String data, right truncation	The string, or binary data is truncated.
22002	Indicator variable required but not supplied	NULL data is bound to the output parameter whose StrLen_or_IndPtr of SQLBindParameter is the null pointer.
24000	Invalid cursor state	<p>The cursor is positioned in StatementHandle through SQLFetch, SQLFetchScroll.</p> <p>The cursor is open but it is not positioned in StatementHandle.</p> <p>*StatementText is the positioned update or delete statement, and the cursor</p>

SQLSTATE	Error	Description
		is positioned before the start or after the end of the result set.
HY000	General error	It is an error without any specific SQLSTATE.
HY001	Memory allocation error	It is a memory allocation error.
HY009	Invalid use of null pointer	*StatementText is the null pointer.
HY010	Function sequence error	After calling SQLExecute, SQLExecDirect, then SQL_NEED_DATA is returned and the function is called before sending all data-at-execution variables.
HY090	Invalid string or buffer length	The argument value of TextLength is smaller than 0, but it is not SQL_NTS.  The parameter value set by SQLBindParameter is the null pointer, and the parameter length is not 0, SQL_NULL_DATA, SQL_DATA_AT_EXEC, SQL_DEFAULT_PARAM, or less than SQL_LEN_DATA_AT_EXEC_OFFSET.  The parameter value set by SQLBindParameter is not the null pointer, and C data type is SQL_C_BINARY or SQL_C_CHAR, and the parameter length is smaller than 0, but it is not less than SQL_NTS, SQL_NULL_DATA, SQL_DATA_AT_EXEC, SQL_DEFAULT_PARAM, or equal to or less than SQL_LEN_DATA_AT_EXEC_OFFSET.
HYT00	Timeout expired	Before returning the result set from the data source, the query timeout is expired. The timeout can be set through SQL_ATTR_QUERY_TIMEOUT of SQLSetStmtAttr.

## Description

The application sends the SQL statement to the data source by calling SQLExecDirect.

The application can include one or more parameter markers in an SQL statement. The application should include a question mark (?) on the appropriate position of SQL statement to include a parameter marker.

If the SQL statement is the SELECT statement and the application connects the cursor with SQLSetCursorName, the driver uses the specified cursor. If the application does not connect the statement and the cursor, then the driver creates a cursor name.

If the data source is the manual commit mode, and the transaction has not yet been started, the driver starts the transaction before sending the SQL statement.

If SQLExecDirect finds the parameter of data-at-execution, it returns SQL\_NEED\_DATA. The application transmits data by using SQLParamData and SQLPutData.

If SQLExecDirect executes the statement such as searched update, insert, or delete, but rows have not been changed on the data source, then calling SQLExecDirect returns SQL\_NO\_DATA.

If the attribute value of `SQL_ATTR_PARAMSET_SIZE` statement is bigger than 1, and the SQL statement includes at least one parameter marker character, then `SQLExecDirect` executes the SQL statement once per a parameter set in the array pointed by `ParameterValuePtr` argument of `SQLBindParameter`.

# SQLExecute

## Conformance

Introduced version: ODBC 1.0

Standards compliance: ISO 92

## Overview

If a statement includes a parameter, SQLExecute performs the prepared statement by using the current value of the parameter marker.

## Syntax

```
SQLRETURN SQLExecute(
    SQLHSTMT    StatementHandle);
```

## Arguments

### StatementHandle

[Input] It is the statement handle.

## Returns

SQL\_SUCCESS, SQL\_SUCCESS\_WITH\_INFO, SQL\_NEED\_DATA, SQL\_STILL\_EXECUTING, SQL\_ERROR, SQL\_NO\_DATA, SQL\_INVALID\_HANDLE, SQL\_PARAM\_DATA\_AVAILABLE

## Diagnosis

SQLSTATE	Error	Description
01004	String data, right truncated	The string or binary data returned to the input/output or output parameters are truncated. The right part of the string is truncated. (The function returns SQL_SUCCESS_WITH_INFO.)
01S02	Option value	It is temporarily replaced with a similar value because the attribute value of the specified statement is not suitable for executing the operation. (SQLGetStmtAttr can be called to see which value is temporarily changed.) The replaced value is valid until the cursor is closed, and it is changed to the previous value when the cursor is closed.

SQLSTATE	Error	Description
	changed	<p>The statement attributes which can be changed are as follows. SQL_ATTR_CONCURRENCY, SQL_ATTR_CURSOR_TYPE, SQL_ATTR_KEYSET_SIZE, SQL_ATTR_MAX_LENGTH, SQL_ATTR_MAX_ROWS, SQL_ATTR_QUERY_TIMEOUT, SQL_ATTR_SIMULATE_CURSOR.</p> <p>(The function returns SQL_SUCCESS_WITH_INFO.)</p>
07006	Restricted data type attribute violation	<p>The data value identified by ValueType argument of SQLBindParameter can not be converted to the data type identified by ParameterType argument of SQLBindParameter.</p> <p>The data value returned to the parameter of SQL_PARAM_INPUT_OUTPUT or SQL_PARAM_OUTPUT can not be converted to the data type identified by ValueType argument of SQLBindParameter.</p> <p>(If one or more rows are successfully returned, the function returns SQL_SUCCESS_WITH_INFO.)</p>
07007	Restricted parameter value violation	The parameter type is SQL_PARAM_INPUT_OUTPUT, and *StrLen_or_IndPtr of SQLBindParameter is not one of SQL_NULL_DATA, SQL_DEFAULT_PARAMETER, SQL_LEN_DATA_AT_EXEC(len), or SQL_DATA_AT_EXEC.
08S01	Communication link failure	Before the function processing is completed, the connection between the driver and the data source is failed.
22001	String data, right truncation	The string, or binary data is truncated.
22002	Indicator variable required but not supplied	NULL data is bound to the output parameter whose StrLen_or_IndPtr of SQLBindParameter is the null pointer.
24000	Invalid cursor state	<p>The cursor is positioned in StatementHandle through SQLFetch, SQLFetchScroll.</p> <p>The cursor is open but it is not positioned in StatementHandle.</p> <p>*StatementText is the positioned update or delete statement, and the cursor is positioned before the start or after the end of the result set.</p>
HY000	General error	It is an error without any specific SQLSTATE.
HY001	Memory allocation error	It is a memory allocation error.
HY009	Invalid use of null pointer	*StatementText is the null pointer.
HY010	Function sequence error	After calling SQLExecute, SQLExecDirect, then SQL_NEED_DATA is returned and the function is called before sending all data-at-execution variables.
		The argument value of TextLength is smaller than 0, but it is not SQL_NTS.



SQLSTATE	Error	Description
HY090	Invalid string or buffer length	<p>The parameter value set by SQLBindParameter is the null pointer, and the parameter length is not 0, SQL_NULL_DATA, SQL_DATA_AT_EXEC, SQL_DEFAULT_PARAM, or less than SQL_LEN_DATA_AT_EXEC_OFFSET.</p> <p>The parameter value set by SQLBindParameter is not the null pointer, and C data type is SQL_C_BINARY or SQL_C_CHAR, and the parameter length is smaller than 0, but it is not less than SQL_NTS, SQL_NULL_DATA, SQL_DATA_AT_EXEC, SQL_DEFAULT_PARAM, or equal to or less than SQL_LEN_DATA_AT_EXEC_OFFSET.</p>
HYT00	Timeout expired	Before returning the result set from the data source, the query timeout is expired. The timeout can be set through SQL_ATTR_QUERY_TIMEOUT of SQLSetStmtAttr.

## Description

SQLExecute executes the statement prepared by SQLPrepare. The application can call SQLExecute again with the new parameter value after it discards the result of calling SQLExecute.

To execute SELECT statement once or more, the application should call SQLCloseCursor before executing SELECT statement again.

If the data source is a manual commit mode, and the transaction has not yet been started, the driver starts the transaction before sending the SQL statement.

If SQLExecute finds a data-at-execution parameter, it returns SQL\_NEED\_DATA. The application sends data by using SQLParamData and SQLPutData.

If SQLExecute executes the statement such as searched update, insert, or delete, but rows have not been changed on the data source, calling SQLExecute returns SQL\_NO\_DATA.

If the attribute value of SQL\_ATTR\_PARAMSET\_SIZE statement is bigger than 1, and the SQL statement includes at least one parameter marker character, then SQLExecute executes the SQL statement once per a parameter set in the array pointed by ParameterValuePtr argument of SQLBindParameter.

# SQLExtendedFetch

## Conformance

Introduced version: ODBC 1.0.

Compliance: It is not available.

## Overview

SQLExtendedFetch fetches the specified data set from the result set, and returns it to all bound columns.

## Syntax

```
SQLRETURN SQLExtendedFetch(  
    SQLHSTMT          StatementHandle,  
    SQLUSMALLINT      FetchOrientation,  
    SQLLEN            FetchOffset,  
    SQLULEN *         RowCountPtr,  
    SQLUSMALLINT *    RowStatusArray);
```

# SQLFetch

## Conformance

Introduced version: ODBC 1.0

Standards compliance: ISO 92

## Overview

SQLFetch fetches the next row set from the result set, and returns it to all columns bound.

## Syntax

```
SQLRETURN SQLFetch(
    SQLHSTMT StatementHandle);
```

## Arguments

### StatementHandle

[Input] It is the statement handle.

## Returns

SQL\_SUCCESS, SQL\_SUCCESS\_WITH\_INFO, SQL\_NO\_DATA, SQL\_STILL\_EXECUTING, SQL\_ERROR, SQL\_INVALID\_HANDLE

## Diagnosis

SQLSTATE	Error	Description
01004	String data, right truncated	The string, binary data returned for the columns are truncated. The right part of the string is truncated.
01S07	Fractional truncation	The data returned for the column is truncated. For numeric data types, the decimal place is truncated. For time, timestamp, interval data types which contain the period component, the decimal place of time is truncated. (The function returns SQL_SUCCESS_WITH_INFO.)
07006	Restricted data type attribute violation	The column data value in the result set can not be converted to the data type specified by TargetType of SQLBindCol.

SQLSTATE	Error	Description
08S01	Communication link failure	Before the function processing is completed, the connection between the driver and the data source is failed.
22002	Indicator variable required but not supplied	StrLen_or_IndPtr (or SQL_DESC_INDICATOR_PTR set by SQLSetDescField or SQLSetDescRec) of SQLBindCol fetches NULL data to the column which is the null pointer.
22003	Numeric value out of range	The integer part (not the decimal place) of the numerical value returned from one or more columns is truncated.
22007	Invalid datetime format	The string in the result set is not the valid date, time, timestamp format.
22012	Division by zero	The result of the arithmetic expression divided by 0 is returned.
22015	Interval field overflow	When the interval C type is specified in the exact numeric or interval SQL data type, the significant figures in the leading field is lost.  The value of SQL type can not be expressed to C interval type.
22018	Invalid character value for cast specification	The character not represented as the character set of C buffer is included in the character column of the result set.  The C type is the exact or approximate numeric, datetime, interval data type, and if the SQL type is the character data type, the value of the column bound to the C type is not valid.
24000	Invalid cursor state	StatementHandle is executed but the result set related to StatementHandle does not exist.
HY000	General error	It is an error without any specific SQLSTATE.
HY001	Memory allocation error	It is a memory allocation error.
HY010	Function sequence error	The StatementHandle specified is not at the state of running. The function is called without calling SQLExecDirect, SQLExecute, the catalog function.  After calling SQLExecute, SQLExecDirect, then SQL_NEED_DATA is returned and the function is called before sending all data-at-execution variables.
HYT00	Timeout expired	Before returning the result set from the data source, the query timeout is expired. The timeout can be set through SQL_ATTR_QUERY_TIMEOUT of SQLSetStmtAttr.

## Description

SQLFetch returns the next data set from the result set. SQLFetch can be called while the result set exists, which is after the result set is created and before the cursor is closed. If the column is bound, the data is returned to the column. If the application specifies the pointer to a row status array or specifies the buffer which returns the number of fetched rows, SQLFetch also returns this information. SQLFetch and SQLFetchScroll can be called being mixed together.

## Cursor Position

If the result set is generated, the cursor is positioned before the start of result set. SQLFetch fetches the next row set. It is as same as calling SQLFetchScroll which FetchOrientation is set to SQL\_FETCH\_NEXT.

The attribute of SQL\_ATTR\_ROW\_ARRAY\_SIZE statement specifies the number of rows in the row set. If the row set fetched by SQLFetch overlaps with the end of result set, SQLFetch returns a partial row set. If S is the start row of fetched row set, R is the size of row set, L is the last row of result set,  $S + R - 1$  is bigger than L, then only the first  $L - S + 1$  rows of row set is valid. All remaining rows are empty, and it becomes the SQL\_ROW\_NOROW state.

After returning SQLFetch, the current row is the first row of row set.

The rules in the following table describes the cursor position according to the conditions in the second table of the session after calling SQLFetch.

Status	The first row of new row set
Before start	1
$\text{CurrRowsetStart} \leq \text{LastResultRow} - \text{RowsetSize}$ [1]	$\text{CurrRowsetStart} + \text{RowsetSize}$ [2]
$\text{CurrRowsetStart} > \text{LastResultRow} - \text{RowsetSize}$ [1]	After end
After end	After end

[1] If the row set size is changed during fetching, the row set size is the row set size used before fetching.

[2] If the row set size is changed during fetching, the row set size is the row set size used in new fetch.

Notation	Description
Before start	The block cursor is positioned before the start of result set. If the first row of new row set is before the start of result set, SQLFetch returns SQL_NO_DATA.
After end	The block cursor is positioned after the end of result set. If the first row of new row set is after the end of result set, SQLFetch returns SQL_NO_DATA.
CurrRowsetStart	It is the first row number of the current row set.
LastResultRow	It is the last row number of result set.
RowsetSize	It is the row set size.

The following is an example of when 100 rows exist in the result set and the row set size is 5, then the following table describes the row set and the return code returned by SQLFetch for the different start position.

Current row set	Return code	New row set	The number of fetched rows
Before start	SQL_SUCCESS	1 to 5	5
1 to 5	SQL_SUCCESS	6 to 10	5
52 to 56	SQL_SUCCESS	57 to 61	5

Current row set	Return code	New row set	The number of fetched rows
91 to 95	SQL_SUCCESS	96 to 100	5
93 to 97	SQL_SUCCESS	98 to 100 4,5 rows of the row status array are set to SQL_ROW_NOROW.	3
96 to 100	SQL_NO_DATA	None	0
99 to 100	SQL_NO_DATA	None	0
After end	SQL_NO_DATA	None	0

## Returning the Data in the Bound Column

Like as SQLFetch returns each row, it inserts the data into each bound column in the buffer bound to the column. If the bound column does not exist, SQLFetch does not return any data, but it does not move the cursor forward. Data can be continuously fetched through SQLGetData. If the cursor is a multiple row cursor (SQL\_ATTR\_ROW\_ARRAY\_SIZE is bigger than 1.), SQLGetData can be called when after setting InfoType of SQLGetInfo to SQL\_FETDATA\_EXTENSIONS, or when returning SQL\_GD\_BLOCK.

For more information, refer to **SQLGetData**.

SQLFetch executes the followings for each bound columns in the row.

1. If data is NULL, the length/indicator buffer is set to SQL\_NULL\_DATA and the next row is processed. If the data is NULL and the length/indicator buffer is not bound, SQLFetch returns SQLSTATE 22002 (Indicator variable required but not supplied) for the row and the next row to be processed. For more information about how to determine the address of the length/indicator, refer to **Buffer Address** of SQLBindCol. If the column data is not NULL, SQLFetch executes the process number 2.
2. If the attribute of SQL\_ATTR\_MAX\_LENGTH statement is set to non-zero and the column includes the character or binary data, the data is truncated to the length of SQL\_ATTR\_MAX\_LENGTH in bytes.



The attribute of SQL\_ATTR\_MAX\_LENGTH statement is intended to reduce network traffic. It is usually implemented by the data source, and the data is truncated before the data is returned from the network. Drivers and data sources are not required to support it. Therefore, the application should specify the size to cbValueMax argument of SQLBindCol and creates the buffer to guarantee that the data is truncated to the specific size.

3. The data is converted to the format specified in TargetType of SQLBindCol.
4. If the data is converted to the variable length data type such as a string or binary, SQLFetch confirms if the data length exceeds the data buffer length. If the character data (including NULL termination character) exceeds the data buffer length, SQLFetch truncates the data to the data buffer length which is smaller than NULL termination character length. In this case, the data is terminated by NULL. If the binary data length exceeds the data buffer length, SQLFetch truncates the data to the data buffer

length. The data buffer length is specified in `BufferLength` of `SQLBindCol`. `SQLFetch` never truncates the data converted to the fixed length data format because the data buffer length is always equal to the data type length.

5. The converted data (truncated data if possible) is put in the data buffer. For more information about how to determine the data buffer address, refer to **Buffer Address** of `SQLBindCol`.
6. The data length is put in the length/indicator buffer. If both the length pointer and indicator pointer are set in the same buffer (by calling `SQLBindCol`), the valid data length is recorded in the buffer, and `SQL_NULL_DATA` is recorded in the buffer if the data is NULL. If the length/indicator buffer is not bound, `SQLFetch` does not return the length.
  - For the character or binary data, it is the data length before truncated after the data is converted because of too small buffer size. If the driver can not determine the length of too long data after conversion, the length is set to `SQL_NO_TOTAL`. If the data is truncated due to the attribute of `SQL_ATTR_MAXIMUM_LENGTH` statement, this attribute value is put in the length/indicator buffer instead of the actual length. It is because the attribute is designed to truncate the data in the server before conversion. So, the driver can not calculate the actual length.
  - For all other data types, it is the data length after conversion.
7. If the data is truncated without any loss of significant digits during conversion (for example, the real number 1.234 is converted into 1 by truncation.), `SQLFetch` returns `SQLSTATE 01S07` (Fractional truncation) and `SQL_SUCCESS_WITH_INFO`. If the data is truncated because the data buffer length is too small (for example the string "abcdef" is put in the buffer of four bytes.), `SQLFetch` returns `SQLSTATE 01004` (Data truncated) and `SQL_SUCCESS_WITH_INFO`. If the data is truncated because of the attribute of `SQL_ATTR_MAXIMUM_LENGTH` statement, `SQLFetch` returns `SQL_SUCCESS` and it does not return `SQLSTATE 01S07` (Fractional truncation) nor `SQLSTATE 01004` (Data truncated). If the significant digits of data is truncated while the data is converted (for example, the value of `SQL_INTEGER` which is bigger than 100,000 is converted into `SQL_C_TINYINT`.), `SQLFetch` returns `SQLSTATE 22003` (Numeric value out of range), `SQL_ERROR` (if the row set size is 1.) or `SQL_SUCCESS_WITH_INFO` (if the row set size is bigger than 1.).

If `SQLFetch`, `SQL_SUCCESS` of `SQLFetchScroll`, or `SQL_SUCCESS_WITH_INFO` is not returned, then the contents of the bound data buffer and the length/indicator buffer are not defined.

## Row Status Array

The row status array is used to return the status of each row set. The array address is specified in the attribute of `SQL_ATTR_ROW_STATUS_PTR` statement. The array should assign the elements as many as specified by the attribute of `SQL_ATTR_ROW_ARRAY_SIZE` statement in the application. The value is set by `SQLFetch`, `SQLFetchScroll`, `SQLBulkOperations` or `SQLSetPos`. If the attribute value of `SQL_ATTR_ROW_STATUS_PTR` statement is the null pointer, the function does not return the row status.

The content of row status buffer is not defined if `SQL_SUCCESS` or `SQL_SUCCESS_WITH_INFO` is not returned by `SQLFetch`, `SQLFetchScroll`.

The following values are returned to the row status array.

The value of row status array	Description
SQL_ROW_SUCCESS	The row is successfully fetched, and it is not changed after the last fetch from the result set.
SQL_ROW_SUCCESS_WITH_INFO	The row is successfully fetched, and it is not changed after the last fetch from the result set. But the warning about the row is returned.
SQL_ROW_ERROR	An error occurs while the row is fetched.
SQL_ROW_UPDATED	The row is successfully fetched, and it is changed after the last fetch from the result set. If the row is fetched again or it is refreshed by SQLSetPos. Status is changed to the new row status.
SQL_ROW_DELETED	It is deleted after the row is fetched last from the result set.
SQL_ROW_NOROW	The row set is overlapped with the end of result set, and returns that there is not a row.

## Row Fetch Buffer

The row fetch buffer is used to return the number of fetched rows. When the data is fetched, the row without data due to an error is also included. It is the number of rows which is not SQL\_ROW\_NOROW value in the row status array. This buffer address is specified in the attribute of SQL\_ATTR\_ROWS\_FETCHED\_PTR statement. The buffer is allocated by the application, and it is set by SQLFetch, SQLFetchScroll. If the attribute value of SQL\_ATTR\_ROWS\_FETCHED\_PTR statement is the null pointer, the function does not return the number of fetched rows. The application calls SQLGetStmtAttr as the attribute of SQL\_ATTR\_ROW\_NUMBER to determine the number of current rows in the result set.

The content of row fetch buffer is not defined if SQLFetch, SQLFetchScroll does not return SQL\_SUCCESS or SQL\_SUCCESS\_WITH\_INFO. If SQL\_NO\_DATA is returned, the value of row fetch buffer is set to 0.

## Error Processing

Errors and warnings can be applied to the individual row or the entire function.

### Error and Warning for Entire Function

If the error is applied to the entire function, as like SQLSTATE HYT00 (Timeout expired) or SQLSTATE 24000 (Invalid cursor state), SQLFetch returns SQL\_ERROR and the corresponding SQLSTATE. The content of row buffer is not defined and the cursor position is not changed.

If the warning is applied to the entire function, SQLFetch returns SQL\_SUCCESS\_WITH\_INFO and the corresponding SQLSTATE. The warning applied to the entire function is returned before the state is recorded to each row.



## Error and Warning for Individual Row

The error such as SQLSTATE 22012 (division by zero) or the warning such as SQLSTATE 01004 (data truncated) is applied to the individual row.

SQLFetch executes the followings.

- It sets the element of row status array to SQL\_ROW\_ERROR for an error or SQL\_ROW\_SUCCESS\_WITH\_INFO for a warning.
- It adds one or more records which includes SQLSTATE for the error or warning.
- It sets the row and column number fields in the status record. If SQLFetch can not determine the row or column number, it sets each number to SQL\_ROW\_NUMBER\_UNKNOWN or SQL\_COLUMN\_NUMBER\_UNKNOWN. If the status record is not applied to the specified column, SQLFetch sets the column number to SQL\_NO\_COLUMN\_NUMBER.

If an error occurs in all rows of the row set (excluding the row in SQL\_ROW\_NOROW status), SQLFetch returns SQL\_ERROR. If an error occurs in some rows, it returns SQL\_SUCCESS\_WITH\_INFO. If the row set size is 1 and an error occurs in the row, SQLFetch returns SQL\_ERROR.

## Descriptor and SQLFetch

SQLFetch uses the following descriptor fields.

Descriptor field	Descriptor	Field location	Setting
SQL_DESC_ARRAY_SIZE	ARD	header	SQL_ATTR_ROW_ARRAY_SIZE statement attribute
SQL_DESC_ARRAY_STATUS_PTR	IRD	header	SQL_ATTR_ROW_STATUS_PTR statement attribute
SQL_DESC_BIND_OFFSET_PTR	ARD	header	SQL_ATTR_ROW_BIND_OFFSET_PTR statement attribute
SQL_DESC_BIND_TYPE	ARD	header	SQL_ATTR_ROW_BIND_TYPE statement attribute
SQL_DESC_COUNT	ARD	header	ColumnNumber argument of SQLBindCol
SQL_DESC_DATA_PTR	ARD	record	TargetValuePtr argument of SQLBindCol
SQL_DESC_INDICATOR_PTR	ARD	record	StrLen_or_IndPtr argument of SQLBindCol
SQL_DESC_OCTET_LENGTH	ARD	record	BufferLength argument of SQLBindCol
SQL_DESC_OCTET_LENGTH_PTR	ARD	record	StrLen_or_IndPtr argument of SQLBindCol
SQL_DESC_ROWS_PROCESSED_PTR	IRD	record	SQL_ATTR_ROWS_FETCHED_PTR statement attribute
SQL_DESC_TYPE	ARD	record	TargetType argument of SQLBindCol

All descriptor fields can be set through SQLSetDescField.

### Separating Length and Indicator Buffer

The application can bind one or two buffers to store the length and indicator value. If the application calls `SQLBindCOL`, `SQL_DESC_OCTET_LENGTH_PTR` and `SQL_DESC_INDICATOR_PTR` field of `ARD` is set in the address passed to `StrLen_or_IndPtr` argument. The application can set the two fields to another address by calling `SQLSetDescField` or `SQLSetDescRec`.

`SQLFetch` determines whether the application specifies a separate length and indicator buffer. If the data is not `NULL`, `SQLFetch` sets the indicator buffer to 0, and returns the length to the length buffer. If the data is `NULL`, `SQLFetch` sets the indicator buffer to `SQL_NULL_DATA`, and it does not modify the length buffer.

# SQLFetchScroll

## Conformance

Introduced version: ODBC 3.0

Standards compliance: ISO 92

## Overview

SQLFetchScroll fetches the specified data set from the result set, and returns it to all bound columns.

## Syntax

```
SQLRETURN SQLFetchScroll(  
    SQLHSTMT    StatementHandle,  
    SQLSMALLINT FetchOrientation,  
    SQLLEN      FetchOffset);
```

## Arguments

### StatementHandle

[Input] It is the statement handle.

### FetchOrientation

[Input] It is the fetch type: SQL\_FETCH\_NEXT, SQL\_FETCH\_PRIOR, SQL\_FETCH\_FIRST, SQL\_FETCH\_LAST, SQL\_FETCH\_ABSOLUTE, SQL\_FETCH\_RELATIVE, SQL\_FETCH\_BOOKMARK

### FetchOffset

[Input] It is the number of rows to fetch. The interpretation of this argument depends on the value of FetchOrientation argument.

## Returns

SQL\_SUCCESS, SQL\_SUCCESS\_WITH\_INFO, SQL\_NO\_DATA, SQL\_STILL\_EXECUTING, SQL\_ERROR, SQL\_INVALID\_HANDLE

## Diagnosis

SQLSTATE	Error	Description
01004	String data, right truncated	The string, binary data returned for the columns are truncated. The right part of the string is truncated.
01S07	Fractional truncation	The data returned for the column is truncated. For numeric data types, the decimal place is truncated. For time, timestamp, interval data types which contain the period component, the decimal place of time is truncated. (The function returns SQL_SUCCESS_WITH_INFO.)
07006	Restricted data type attribute violation	The column data value in the result set can not be converted to the data type specified by TargetType of SQLBindCol.
08S01	Communication link failure	Before the function processing is completed, the connection between the driver and the data source is failed.
22002	Indicator variable required but not supplied	StrLen_or_IndPtr (or SQL_DESC_INDICATOR_PTR set by SQLSetDescField or SQLSetDescRec) of SQLBindCol fetches NULL data to the column which is the null pointer.
22003	Numeric value out of range	The integer part (not the decimal place) of the numerical value returned from one or more columns is truncated.
22007	Invalid datetime format	The string in the result set is not the valid date, time, timestamp format.
22012	Division by zero	The result of the arithmetic expression divided by 0 is returned.
22015	Interval field overflow	When the interval C type is specified in the exact numeric or interval SQL data type, the significant figures in the leading field is lost.  The value of SQL type can not be expressed to C interval type.
22018	Invalid character value for cast specification	The character not represented as the character set of C buffer is included in the character column of the result set.  The C type is the exact or approximate numeric, datetime, interval data type, and if the SQL type is the character data type, the value of the column bound to the C type is not valid.
24000	Invalid cursor state	StatementHandle is executed but the result set related to StatementHandle does not exist.
HY000	General error	It is an error without any specific SQLSTATE.
HY001	Memory allocation error	It is a memory allocation error.
HY010	Function sequence error	The StatementHandle specified is not at the state of running. The function is called without calling SQLExecDirect, SQLExecute, the catalog function.  After calling SQLExecute, SQLExecDirect, then SQL_NEED_DATA is returned and the function is called before sending all data-at-execution variables.
		The value specified to FetchOrientation argument is not valid.

SQLSTATE	Error	Description
HY106	Fetch type out of range	The attribute value of SQL_ATTR_CURSOR_TYPE statement is SQL_CURSOR_FORWARD_ONLY, and the value of FetchOrientation argument is not SQL_FETCH_NEXT.  The attribute value of SQL_ATTR_CURSOR_SCROLLABLE statement is SQL_NONSCROLLABLE, and the value of FetchOrientation argument is not SQL_FETCH_NEXT.
HYT00	Timeout expired	Before returning the result set from the data source, the query timeout is expired. The timeout can be set through SQL_ATTR_QUERY_TIMEOUT of SQLSetStmtAttr.

## Description

SQLFetchScroll returns the specified row set in the result set. The row set is set as the absolute or relative position or the bookmark position. SQLFetchScroll can be called while the result set exists, which is after the result set is created and before the cursor is closed. If the column is bound, the data is returned to the column. If the application specifies the pointer to a row status array or specifies the buffer which returns rows fetched, SQLFetchScroll also returns this information. SQLFetch and SQLFetchScroll can be called being mixed together.

## Cursor Position

If the result set is created, the cursor is positioned before the start of result set. SQLFetchScroll positions the block cursor according to FetchOrientation argument and FetchOffset argument as follows. The following rules are used to determine the beginning of new row set.

FetchOrientation	Description
SQL_FETCH_NEXT	It returns the next row set. it is as same as calling SQLFetch. SQLFetchScroll ignores the value of FetchOffset.
SQL_FETCH_PRIOR	It returns the previous row set. SQLFetchScroll ignores the value of FetchOffset.
SQL_FETCH_RELATIVE	It returns the row set of FetchOffset at the beginning of current row set.
SQL_FETCH_ABSOLUTE	It returns the row set starting at FetchOffset.
SQL_FETCH_FIRST	It returns the first row set in the result set. SQLFetchScroll ignores the value of FetchOffset.
SQL_FETCH_LAST	It returns the last complete row set in the result set. SQLFetchScroll ignores the value of FetchOffset.
SQL_FETCH_BOOKMARK	It returns the row set of FetchOffset on the bookmark specified by the attribute of SQL_ATTR_FETCH_BOOKMARK_PTR statement.

The attribute of SQL\_ATTR\_ROW\_ARRAY\_SIZE statement specifies the number of rows of the row set. If

the row set fetched by SQLFetchScroll overlaps with the end of result set, SQLFetchScroll returns a partial row set. If  $S$  is the start row of fetched row set,  $R$  is the row set size,  $L$  is the last row of result set,  $S + R - 1$  is bigger than  $L$ , and the first  $L - S + 1$  rows of row set is valid. All remaining rows are empty, and it becomes SQL\_ROW\_NOROW state.

After returning SQLFetchScroll, the current row is the first row of row set.

## Cursor Position Rules

The following chapters describe rules for each FetchOrientation. The following notations are used for the rules.

Notation	Meaning
Before start	The block cursor is positioned before the start of result set. If the first row of the new row set is before the start of the result set, SQLFetchScroll returns SQL_NO_DATA.
After end	The block cursor is positioned after the end of result set. If the first row of the new row set is after the end of the result set, SQLFetchScroll returns SQL_NO_DATA.
CurrRowsetStart	It is the first row number of current row set.
LastResultRow	It is the last row number of result set.
RowsetSize	It is the row set size.
FetchOffset	It is the value of FetchOffset argument.
BookmarkRow	It is the row which corresponds to the bookmark specified by the attribute of SQL_ATTR_FETCH_BOOKMARK_PTR statement.

### SQL\_FETCH\_NEXT

The following rule is applied.

State	The first row of the new row set
Before start	1
$\text{CurrRowsetStart} + \text{RowsetSize}[1] \leq \text{LastResultRow}$	$\text{CurrRowsetStart} + \text{RowsetSize}[1]$
$\text{CurrRowsetStart} + \text{RowsetSize}[1] > \text{LastResultRow}$	After end
After end	After end

[1] If the row set size is changed during fetching the row set size is the row set size used before fetching.

### SQL\_FETCH\_PRIOR

The following rule is applied.

State	The first row of the new row set
Before start	Before start
$\text{CurrRowsetStart} = 1$	Before start
$1 < \text{CurrRowsetStart} \leq \text{RowsetSize}[1]$	1

State	The first row of the new row set
$\text{CurrRowsetStart} > \text{RowsetSize}[1]$	$\text{CurrRowsetStart} - \text{RowsetSize}[1]$
After end AND $\text{LastResultRow} < \text{RowsetSize}[1]$	1
After end AND $\text{LastResultRow} \geq \text{RowsetSize}[1]$	$\text{LastResultRow} - \text{RowsetSize} + 1[1]$

[1] If the row set size is changed during fetching, the row set size is the row set size used in new fetch.

### SQL\_FETCH\_RELATIVE

The following rule is applied.

State	The first row of the new row set
(Before start AND $\text{FetchOffset} > 0$ ) OR (After end AND $\text{FetchOffset} < 0$ )	__ [1]
BeforeStart AND $\text{FetchOffset} \leq 0$	Before start
$\text{CurrRowsetStart} = 1$ AND $\text{FetchOffset} < 0$	Before start
$\text{CurrRowsetStart} > 1$ AND $\text{CurrRowsetStart} + \text{FetchOffset} < 1$ AND $ \text{FetchOffset}  > \text{RowsetSize}[2]$	Before start
$\text{CurrRowsetStart} > 1$ AND $\text{CurrRowsetStart} + \text{FetchOffset} < 1$ AND $ \text{FetchOffset}  \leq \text{RowsetSize}[2]$	1
$1 \leq \text{CurrRowsetStart} + \text{FetchOffset} \leq \text{LastResultRow}$	$\text{CurrRowsetStart} + \text{FetchOffset}$
$\text{CurrRowsetStart} + \text{FetchOffset} > \text{LastResultRow}$	After end
After end AND $\text{FetchOffset} \geq 0$	After end

[1] SQLFetchScroll returns the row set as same as when FetchOrientation is set to SQL\_FETCH\_ABSOLUTE and it is called.

[2] If the row set size is changed during fetching, the row set size is the row set size used in new fetch.

### SQL\_FETCH\_ABSOLUTE

The following rule is applied.

State	The first row of the new row set
$\text{FetchOffset} < 0$ AND $ \text{FetchOffset}  \leq \text{LastResultRow}$	$\text{LastResultRow} + \text{FetchOffset} + 1$
$\text{FetchOffset} < 0$ AND $ \text{FetchOffset}  > \text{LastResultRow}$ AND $ \text{FetchOffset}  > \text{RowsetSize}[1]$	Before start
$\text{FetchOffset} < 0$ AND $ \text{FetchOffset}  > \text{LastResultRow}$ AND $ \text{FetchOffset}  \leq \text{RowsetSize}[1]$	1
$\text{FetchOffset} = 0$	Before start
$1 \leq \text{FetchOffset} \leq \text{LastResultRow}$	$\text{FetchOffset}$
$\text{FetchOffset} > \text{LastResultRow}$	After end

[1] If the row set size is changed during fetching, the row set size is the row set size used in new fetch.

### SQL\_FETCH\_FIRST

The following rule is applied.

State	The first row of the new row set
Any	1

### SQL\_FETCH\_LAST

The following rule is applied.

State	The first row of the new row set
$\text{RowsetSize}[1] \leq \text{LastResultRow}$	$\text{LastResultRow} - \text{RowsetSize} + 1[1]$
$\text{RowsetSize}[1] > \text{LastResultRow}$	1

[1] If the row set size is changed during fetching, the row set size is the row set size used in new fetch.

### SQL\_FETCH\_BOOKMARK

The following rule is applied.

State	The first row of the new row set
$\text{BookmarkRow} + \text{FetchOffset} < 1$	Before start
$1 \leq \text{BookmarkRow} + \text{FetchOffset} \leq \text{LastResultRow}$	$\text{BookmarkRow} + \text{FetchOffset}$
$\text{BookmarkRow} + \text{FetchOffset} > \text{LastResultRow}$	After end

## Buffer Address

SQLFetchScroll determines the data address and length/indicator buffer address in the same way as SQLFetch. For more information, refer to **Buffer Address** of SQLBindCol.

## Row Status Array

SQLFetchScroll sets the row status array in the same way as SQLFetch. For more information, refer to **Row Status Array** of SQLFetch.

## Row Fetch Buffer

SQLFetchScroll returns the number of rows fetched in the same way as SQLFetch. For more information, refer to **Row Fetch Buffer** of SQLFetch.



## Error Processing

SQLFetchScroll returns the errors and warning in the same way as SQLFetch. For more information, refer to [Error Processing](#) of SQLFetch.

# SQLForeignKeys

## Conformance

Introduced version: ODBC 1.0

Standards compliance: ODBC

## Overview

SQLForeignKeys returns the followings.

- The foreign key list of the specified table (the column in the specified table which refers to the the primary key of another table)
- The foreign key list of another table which refers to the primary key of the specified table

The driver returns each list as the result set.

## Syntax

```
SQLRETURN SQLForeignKeys(
    SQLHSTMT      StatementHandle,
    SQLCHAR *     PKCatalogName,
    SQLSMALLINT   NameLength1,
    SQLCHAR *     PKSchemaName,
    SQLSMALLINT   NameLength2,
    SQLCHAR *     PKTableName,
    SQLSMALLINT   NameLength3,
    SQLCHAR *     FKCatalogName,
    SQLSMALLINT   NameLength4,
    SQLCHAR *     FKSchemaName,
    SQLSMALLINT   NameLength5,
    SQLCHAR *     FKTableName,
    SQLSMALLINT   NameLength6);
```

## Arguments

### StatementHandle

[Input] It is the statement handle

**PKCatalogName**

[Input] It is the primary key table catalog name. PKCatalogName can not include the string search pattern.

If the attribute of SQL\_ATTR\_METADATA\_ID statement is set to SQL\_TRUE, then PKCatalogName is treated as a case-insensitive identifier. If it is set to SQL\_FALSE, then PKCatalogName is case-sensitive, and it is an ordinary argument literally processed.

**NameLength1**

[Input] It is the length of \*PKCatalogName

**PKSchemaName**

[Input] It is the primary key table schema name. PKSchemaName can not include the string search pattern.

If the attribute of SQL\_ATTR\_METADATA\_ID statement is set to SQL\_TRUE, then PKSchemaName is treated as a case-insensitive identifier. If it is set to SQL\_FALSE, then PKSchemaName is case-sensitive, and it is an ordinary argument literally processed.

**NameLength2**

[Input] It is the length of \*PKSchemaName

**PKTableName**

[Input] It is the primary key table name. PKTableName can not include the string search pattern.

If the attribute of SQL\_ATTR\_METADATA\_ID statement is set to SQL\_TRUE, then PKTableName is treated as a case-insensitive identifier. If it is set to SQL\_FALSE, then PKTableName is case-sensitive, and it is an ordinary argument literally processed.

**NameLength3**

[Input] It is the length of \*PKTableName

**FKCatalogName**

[Input] It is the foreign key table catalog name. FKCatalogName can not include the string search pattern.

If the attribute of SQL\_ATTR\_METADATA\_ID statement is set to SQL\_TRUE, then FKCatalogName is treated as a case-insensitive identifier. If it is set to SQL\_FALSE, then FKCatalogName is case-sensitive, and it is an ordinary argument literally processed.

**NameLength4**

[Input] It is the length of \*FKCatalogName

**FKSchemaName**

[Input] It is the foreign key table schema name. FKSchemaName can not include the string search pattern.

If the attribute of SQL\_ATTR\_METADATA\_ID statement is set to SQL\_TRUE, FKSchemaName is treated as a case-insensitive identifier. If it is set to SQL\_FALSE, FKSchemaName is case-sensitive, and it is an ordinary argument literally processed.

**NameLength5**

[Input] It is the length of \*FKSchemaName

**FKTableName**

[Input] It is the foreign key table name. FKTableName can not include the string search pattern.

If the attribute of SQL\_ATTR\_METADATA\_ID statement is set to SQL\_TRUE, then FKTableName is treated as a case-insensitive identifier. If it is set to SQL\_FALSE, FKTableName is case-sensitive, and it is an ordinary argument literally processed.

**NameLength6**

[Input] It is the length of \*FKTableName

**Returns**

SQL\_SUCCESS, SQL\_SUCCESS\_WITH\_INFO, SQL\_STILL\_EXECUTING, SQL\_ERROR, SQL\_INVALID\_HANDLE

**Diagnosis**

SQLSTATE	Error	Description
08S01	Communication link failure	Before the function processing is completed, the connection between the driver and the data source is failed.
24000	Invalid cursor state	SQLFetch, SQLFetchScroll are called and a cursor is open.
HY000	General error	It is an error without any specific SQLSTATE.
HY001	Memory allocation error	It is a memory allocation error.
HY009	Invalid use of null pointer	The PKTableName argument and FKTableName argument are the null pointer.  The attribute value of SQL_ATTR_METADATA_ID statement is SQL_TRUE, and the arguments of PKSchemaName, FKSchemaName, PKTableName or FKTableName are the null pointer.
HY010	Function sequence error	After calling SQLExecute, SQLExecDirect, then SQL_NEED_DATA is returned and the function is called before sending all data-at-execution variables.
HY090	Invalid string or buffer length	A name length argument value is smaller than 0, but it is not SQL_NTS.
HYT00	Timeout expired	Before returning the result set from the data source, the query timeout is expired. The timeout can be set through SQL_ATTR_QUERY_TIMEOUT of SQLSetStmtAttr.

## Description

If \*PKTableName includes the table name, SQLForeignKeys returns a result set which includes the primary key of the specified table and all foreign keys referring it. The foreign key list of another table does not include the foreign key pointing to the unique constraint on the specified table.

If \*FKTableName includes the table name, SQLForeignKeys returns the result set which contains the foreign key in the specified table pointing to the primary key of another table, and returns its primary key of another table which is referenced by them.

If both \*PKTableName and \*FKTableName include the table name, SQLForeignKeys returns the foreign key of the table specified in \*FKTableName which refers to the primary key of the table specified in \*PKTableName. The key should be one.

SQLForeignKeys returns the standard result set. If the foreign key related to the primary key is requested, the result set is sorted as FKTABLE\_CAT, FKTABLE\_SCHEM, FKTABLE\_NAME, KEY\_SEQ. If the primary key related to the foreign key is requested, the result set is sorted as PKTABLE\_CAT, PKTABLE\_SCHEM, PKTABLE\_NAME, KEY\_SEQ.

The following table describes the columns of result set.

Column name	Column number	Data type	Description
PKTABLE_CAT (ODBC 1.0)	1	VARCHAR	It is the primary key table catalog name.
PKTABLE_SCHEM (ODBC 1.0)	2	VARCHAR	It is the primary key table schema name.
PKTABLE_NAME (ODBC 1.0)	3	VARCHAR not NULL	It is the primary key table name.
PKCOLUMN_NAME (ODBC 1.0)	4	VARCHAR not NULL	It is the primary key column name. The driver returns an empty string for a column which does not have a name.
FKTABLE_CAT (ODBC 1.0)	5	VARCHAR	It is the foreign key table catalog name.
FKTABLE_SCHEM (ODBC 1.0)	6	VARCHAR	It is the foreign key table schema name.
FKTABLE_NAME (ODBC 1.0)	7	VARCHAR not NULL	It is the foreign key table name.
FKCOLUMN		VARCHAR not NULL	It is the foreign key column name. The driver returns an empty string for

Column name	Column number	Data type	Description
_NAME (ODBC 1.0)	8	not NULL	is a column which does not have a name.
KEY_SEQ (ODBC 1.0)	9	SMALLINT not NULL	It is the column sequential number of the key starting from 1.
UPDATE_RULE (ODBC 1.0)	10	SMALLINT	<p>It is the operation applied to the foreign key when the SQL operation is UPDATE. (The referenced table has the primary key, and the referring table has the foreign key.)</p> <ul style="list-style-type: none"> <li>• SQL_CASCADE: If the primary key of referencing table is updated, the foreign key of the referring table is also updated.</li> <li>• SQL_NO_ACTION: If a row in the referring table does not correspond to the referenced table when updating the primary key of the referenced table, the update is rejected. If the foreign key update of the referring table does not exist as the value of the primary key of the referenced table, the update is rejected.</li> <li>• SQL_SET_NULL: If one or more rows in the referenced table are updated in a way that one or more components of the primary key are changed, the components of the foreign key in the referring table which corresponds to the changed components of the primary key are set to NULL in all matching rows of the referring table.</li> <li>• SQL_SET_DEFAULT: If one or more rows in the referenced table are updated in a way that one or more components of the primary key are changed, the components of the foreign key in the referring table which corresponds to the changed components of the primary key are set to the default value in all matching rows of the referring table.</li> </ul>
DELETE_RULE (ODBC 1.0)	11	SMALLINT	<p>It is the operation applied to the foreign key when the SQL operation is DELETE. (The referenced table has the primary key, and the referring table has the foreign key.)</p> <ul style="list-style-type: none"> <li>• SQL_CASCADE: If the primary key of referenced table is deleted, the foreign key of the referring table is also deleted.</li> <li>• SQL_NO_ACTION: If a row in the referring table does not correspond to the referenced table when deleting the primary key of the referenced table, the update is rejected.</li> <li>• SQL_SET_NULL: If one or more rows of the referenced table are deleted, each components of the foreign key of the referring table is set to NULL in all matching rows of the referring table.</li> <li>• SQL_SET_DEFAULT: If one or more rows of the referenced table a</li> </ul>

Column name	Column number	Data type	Description
			re deleted, each component of the foreign key of the referencing table is set to the applicable default in all matching rows of the referencing table.
FK_NAME (ODBC 2.0)	12	VARCHAR	It is the foreign key name.
PK_NAME (ODBC 2.0)	13	VARCHAR	It is the primary key name.
DEFERRABILITY (ODBC 3.0)	14	SMALLINT	SQL_INITIALLY_DEFERRED, SQL_INITIALLY_IMMEDIATE, SQL_NOT_DEFERRABLE.

# SQLFreeConnect

## Conformance

Introduced version: ODBC 1.0

Standards compliance: It is not available.

## Overview

SQLFreeConnect function is replaced with SQLFreeHandle function in ODBC 3.x.

For more information, refer to **SQLFreeHandle**.



# SQLFreeEnv

## Conformance

Introduced version: ODBC 1.0

Standards compliance: It is not available.

## Overview

SQLFreeEnv function is replaced with SQLFreeHandle function in ODBC 3.x.

For more information, refer to [SQLFreeHandle](#).

# SQLFreeHandle

## Conformance

Introduced version: ODBC 3.0

Standards compliance: ISO 92

## Overview

SQLFreeHandle releases the resources related to the specified environment, connection, statement, and descriptor handles.

## Syntax

```
SQLRETURN SQLFreeHandle(  
    SQLSMALLINT  HandleType,  
    SQLHANDLE     Handle);
```

## Arguments

### HandleType

[Input] It is the handle type to be released by using SQLFreeHandle. It should be one of SQL\_HANDLE\_DBC, SQL\_HANDLE\_DESC, SQL\_HANDLE\_ENV, SQL\_HANDLE\_STMT.

If HandleType is not one of the values above, SQLFreeHandle returns SQL\_INVALID\_HANDLE.

### Handle

[Input] It is the handle to be released.

## Returns

SQL\_SUCCESS, SQL\_ERROR, SQL\_INVALID\_HANDLE.

If SQLFreeHandle returns SQL\_ERROR, the handle is still valid.

## Diagnosis

SQLSTATE	Error	Description
HY000	General error	It is an error without any specific SQLSTATE.
HY001	Memory allocatio	It is a memory allocation error.

SQLSTATE	Error	Description
	n error	
HY010	Function sequence error	<p>HandleType argument is SQL_HANDLE_ENV, and at least one connection is assigned or connected. Before calling SQLFreeHandle whose HandleType argument is SQL_HANDLE_ENV, SQLDisconnect and SQLFreeHandle argument whose HandleType argument is SQL_HANDLE_DBC should be called.</p> <p>HandleType argument is SQL_HANDLE_DBC, the function is called before SQLDisconnect is called.</p> <p>HandleType argument is SQL_HANDLE_STMT, after calling SQLExecute, SQLExecDirect, then SQL_NEED_DATA is returned and the function is called before sending all data-at-execution variables.</p>

## Description

SQLFreeHandle is used to release the environment, connection, statement, descriptor handles. After the handle is released, the application can not use the released handle.

### Releasing the Environment Handle

Before calling SQLFreeHandle whose HandleType is SQL\_HANDLE\_ENV, the application should call SQLFreeHandle whose HandleType is SQL\_HANDLE\_DBC for all connection allocated from the environment. Otherwise, SQLFreeHandle returns SQL\_ERROR, and the environment and active connection remain valid.

### Releasing the Connection Handle

Before calling SQLFreeHandle whose HandleType is SQL\_HANDLE\_DBC, if the handle is connected, the application should call SQLDisconnect. Otherwise, SQLFreeHandle returns SQL\_ERROR, and the connection remains valid.

### Releasing the Statement Handle

SQLFreeHandle whose HandleType is SQL\_HANDLE\_STMT, releases all resources allocated by calling SQLAllocHandle whose HandleType is SQL\_HANDLE\_STMT. If the application calls SQLFreeHandle with the remaining statement, the remaining result is deleted. When the application releases the statement handle, the driver releases the four auto allocation descriptors related to the statement.

SQLDisconnect automatically deletes all statements and descriptors which are opened for the connection.

# SQLFreeStmt

## Conformance

Introduced version: ODBC 1.0

Standards compliance: ISO 92

## Overview

SQLFreeStmt stops the processing related to the specified statement, closes an open cursor, removes the remaining result or selectively releases all resources connected to the statement handle.

## Syntax

```
SQLRETURN SQLFreeStmt(  
    SQLHSTMT      StatementHandle,  
    SQLUSMALLINT  Option);
```

## Arguments

### StatementHandle

[Input] It is the statement handle.

### Option

[Input] It is one of the following options.

- **SQL\_CLOSE**: It closes the cursor related to StatementHandle, and deletes the remaining result. The application executes SELECT statement with the same or different parameter values, and it can open cursor again later. If the cursor is not open, this option does not affect the application. SQLCloseCursor also closes the cursor.
- **SQL\_DROP**: This option is not used any more.
- **SQL\_UNBIND**: It releases all column buffers bound with SQLBindCol for the specified StatementHandle, and sets SQL\_DESC\_COUNT field of ARD to 0.
- **SQL\_RESET\_PARAMS**: It releases all parameter buffers set to SQLBindParameter for the specified StatementHandle, and sets SQL\_DESC\_COUNT field of APD to 0.

## Returns

SQL\_SUCCESS, SQL\_SUCCESS\_WITH\_INFO, SQL\_ERROR, SQL\_INVALID\_HANDLE

## Diagnosis

SQLSTATE	Error	Description
HY000	General error	It is an error without any specific SQLSTATE.
HY001	Memory allocation error	It is a memory allocation error.
HY010	Function sequence error	After calling SQLExecute, SQLExecDirect, then SQL_NEED_DATA is returned and the function is called before sending all data-at-execution variables.
HY092	Option type out of range	The value of option argument is not SQL_CLOSE, SQL_DROP, SQL_UNBIND, SQL_RESET_PARAMS.

## Description

Calling SQLFreeStmt with SQL\_CLOSE option is as same as calling of SQLCloseCursor. However, if an open cursor does not exist, calling SQLFreeStmt with SQL\_CLOSE option does not affect the application. SQLCloseCursor returns SQLSTATE 24000 (Invalid cursor state).

# SQLGetConnectAttr

## Conformance

Introduced version: ODBC 3.0

Standards compliance: ISO 92

## Overview

SQLGetConnectAttr returns the current setting of the connection attribute.

## Syntax

```
SQLRETURN SQLGetConnectAttr(  
    SQLHDBC      ConnectionHandle,  
    SQLINTEGER   Attribute,  
    SQLPOINTER   ValuePtr,  
    SQLINTEGER   BufferLength,  
    SQLINTEGER *  StringLengthPtr);
```

## Arguments

### ConnectionHandle

[Input] It is the connection handle.

### Attribute

[Input] It is the attribute to be searched

### ValuePtr

[Output] It is a memory pointer which returns the current setting value of the attribute specified by Attribute.

If ValuePtr is null, StringLengthPtr returns the total number of bytes returnable (excluding the null-termination character).

### BufferLength

[Input] If Attribute is a defined field in ODBC and ValuePtr points to the string or binary buffer, this argument should be the length of \*ValuePtr. If Attribute is a defined field in ODBC and \*ValuePtr is an integer, this argument is ignored.

## StringLengthPtr

[Output] It is the pointer which returns the total number of bytes returnable in \*Value\_Ptr (excluding null-termination byte for character data)

For the character data, if the number of returnable bytes is equal to or bigger than BufferLength, \*ValuePtr is truncated to length of BufferLength minus 1, and it is null terminated by the driver.

## Returns

SQL\_SUCCESS, SQL\_SUCCESS\_WITH\_INFO, SQL\_NO\_DATA, SQL\_ERROR, SQL\_INVALID\_HANDLE

## Diagnosis

SQLSTATE	Error	Description
01004	String data, right truncated	The data truncated to the length of BufferLength minus null-termination character is returned to *ValuePtr. The length of string not truncated is returned to *StringLengthPtr. (The function returns SQL_SUCCESS_WITH_INFO.)
08003	Connection not open	The Attribute value required on the connection status is specified.
08S01	Communication link failure	Before the function processing is completed, the connection between the driver and the data source is failed.
HY000	General error	It is an error without any specific SQLSTATE.
HY001	Memory allocation error	It is a memory allocation error.
HY090	Invalid string or buffer length	*ValuePtr is a string, and BufferLength is smaller than 0 but it is not SQL_NTS.
HY092	Invalid attribute/option identifier	The Attribute argument value is not valid.
HYC00	Optional feature not implemented	The Attribute argument value is valid but it is not supported by the driver.

## Description

If an attribute specifies the attribute which returns the string, ValuePtr should have the pointer to the string buffer. The maximum length of the returned string including null-termination character is BufferLength in bytes.

Attribute	The description of ValuePtr
SQL_ATTR_ACCESS_MODE (ODBC 1.0)	It is the SQLINTEGER value. SQL_MODE_READ_ONLY is used as the indicator of the connection which does not request the update. This mode is used for the transaction management, the optimization, and the lock plan of the driver or data source.

Attribute	The description of ValuePtr
	The default value is SQL_MODE_READ_WRITE.
SQL_ATTR_AUTOCOMMIT (ODBC 1.0)	<p>It is SQLINTEGER value which specifies whether to use auto commit or manual commit.</p> <ul style="list-style-type: none"> <li>• SQL_AUTOCOMMIT_ON: It is the default value. The driver uses the auto commit mode. Each statement is immediately committed after execution. When SQL_ATTR_AUTOCOMMIT is set to SQL_AUTOCOMMIT_ON, the open transaction is committed to the connection to change from the manual commit mode to the auto commit mode.</li> <li>• SQL_AUTOCOMMIT_OFF: The driver uses the manual commit mode, and the application should explicitly commit or rollback with SQLEndTrans.</li> </ul>
SQL_ATTR_CHARACTERSET	It is the character set string of the driver.
SQL_ATTR_DATABASE_CHARACTERSET	It is the character set string of the data source.
SQL_ATTR_DATE_FORMAT	It is the DATE format string of the driver.
SQL_ATTR_LOGIN_TIMEOUT (ODBC 1.0)	It is the waiting time (in seconds) for a login request with SQLINTEGER value. If ValuePtr is 0, timeout is not used, and the connection attempt indefinitely wait.
SQL_ATTR_METADATA_ID (ODBC 3.0)	<p>It is SQLINTEGER value which determines the string argument of the catalog function.</p> <p>If it is SQL_TRUE, the string argument of catalog function is treated as an identifier, and it is case-insensitive. If the string is not separated by a delimiter, the driver removes all leading or trailing spaces and the string is capitalized. If the string is separated by a delimiter, the driver removes all leading or trailing spaces and the string between delimiters remains literally. If one of the arguments is set to the null pointer, the function returns SQL_ERROR and SQLSTATE HY009 (Invalid use of null pointer).</p> <p>If it is SQL_FALSE, the string argument of catalog function is not treated as an identifier. It may or may not include a search string pattern depending on the string argument.</p> <p>The default value is SQL_FALSE.</p> <p>SQL_ATTR_METADATA_ID can also be set in the statement level.</p>
SQL_ATTR_TIMESTAMP_FORMAT	It is the TIMESTAMP format string of the driver.
SQL_ATTR_TIMESTAMP_WITH_TIMEZONE_FORMAT	It is the TIMESTAMP WITH TIME ZONE format string of the driver.
SQL_ATTR_TIMEZONE	It is the timezone string of the driver.
SQL_ATTR_TIME_FORMAT	It is the TIME format string of the driver.
SQL_ATTR_TIME_WITH_TIMEZONE_FORMAT	It is the TIME WITH TIME ZONE format string of the driver.



Attribute	The description of ValuePtr
MEZONE_FORMAT	
SQL_ATTR_TXN_ISOLATION (ODBC 1.0)	It is 32-bit mask which sets the isolation level for the current connection.

# SQLGetConnectOption

## Conformance

Introduced version: ODBC 1.0

Standards compliance: It is not available.

## Overview

SQLGetConnectOption function is replaced with SQLGetConnectAttr function in ODBC 3.x.

For more information, refer to [SQLGetConnectAttr](#).

# SQLGetCursorName

## Conformance

Introduced version: ODBC 1.0

Standards compliance: ISO 92

## Overview

SQLGetCursorName returns the specified statement and related cursor name.

## Syntax

```
SQLRETURN SQLGetCursorName(  
    SQLHSTMT      StatementHandle,  
    SQLCHAR *     CursorName,  
    SQLSMALLINT   BufferLength,  
    SQLSMALLINT * NameLengthPtr);
```

## Arguments

### StatementHandle

[Input] It is the statement handle.

### CursorName

[Output] It is the buffer pointer which returns the cursor name

If CursorName is NULL, NameLengthPtr returns the returnable byte length (excluding the null-termination character)

### BufferLength

[Input] It is the length of \*CursorName.

### NameLengthPtr

[Output] It is the memory pointer for the length of bytes returnable to \*CursorName (excluding the null-termination character). If the returnable byte length is equal to or bigger than it, \*sCursorName is truncated to the length of BufferLength minus 1.

## Returns

SQL\_SUCCESS, SQL\_SUCCESS\_WITH\_INFO, SQL\_ERROR, SQL\_INVALID\_HANDLE

## Diagnosis

SQLSTATE	Error	Description
01004	String data, right truncated	*CursorName buffer is not large enough to return the entire cursor name, so the cursor name is truncated. The length of cursor name not truncated is returned to *NameLengthPtr. (The function returns SQL_SUCCESS_WITH_INFO.)
HY000	General error	It is an error without any specific SQLSTATE.
HY001	Memory allocation error	It is a memory allocation error.
HY010	Function sequence error	After calling SQLExecute, SQLExecDirect, then SQL_NEED_DATA is returned and the function is called before sending all data-at-execution variables.
HY090	Invalid string or buffer length	The value of BufferLength argument is smaller than 0.

## Description

The cursor name is used only in positioned update and positioned delete statements. (e.g. UPDATE table-name ...WHERE CURRENT OF cursor-name) If the cursor name is not set with SQLSetCursorName in the application, the driver generates the cursor name starting with SQL\_CUR.

SQLGetCursorName can re-set the cursor name, if the statement is the assigned or ready state.

The cursor name which is explicitly or implicitly set is valid until the related statement is deleted by calling SQLFreeHandle whose HandleType is SQL\_HANDLE\_STMT.

# SQLGetData

## Conformance

Introduced version: ODBC 1.0

Standards compliance: ISO 92

## Overview

SQLGetData retrieves a column data in the result set, and it can be called multiple times to retrieve the variable length data.

## Syntax

```
SQLRETURN SQLGetData(  
    SQLHSTMT      StatementHandle,  
    SQLUSMALLINT  Col_or_Param_Num,  
    SQLSMALLINT   TargetType,  
    SQLPOINTER    TargetValuePtr,  
    SQLLEN        BufferLength,  
    SQLLEN *      StrLen_or_IndPtr);
```

## Arguments

### StatementHandle

[Input] It is the statement handle.

### Col\_or\_Param\_Num

[Input] It is the column number for retrieving the column data from the returned data. Result set columns are numbered in increasing order, starting from 1.

### TargetType

[Input] It is the C data type identifier of \*TargetValuePtr buffer.

If TargetType is SQL\_ARD\_TYPE, the driver uses the type identifier specified in SQL\_DESC\_CONCISE\_TYPE field of ARD.

### TargetValuePtr

[Output] It is the buffer pointer to which the data is returned

TargetValuePtr can not be NULL.

**BufferLength**

[Input] It is the byte length of \*TargetValuePtr buffer.

When the driver returns the variable length data such as string or binary data, it uses BufferLength to avoid writing beyond the end of \*TargetValuePtr buffer. Be cautious when returning character data to \*TargetValuePtr because the driver calculates the null-termination character. Therefore, \*TargetValuePtr should include the space for the null-termination character. Otherwise, the driver can truncate the data.

When the driver returns the fixed length data such as integer or date structure, the driver assumes that the buffer is large enough to store the data, and it ignores BufferLength. Therefore, the application should allocate the buffer which is large enough to the fixed length data. If not, the driver can write beyond the end of buffer.

SQLGetData returns SQLSTATE HY090(Invalid string or buffer length), if BufferLength is smaller than 0.

**StrLen\_or\_IndPtr**

[Output] It is the buffer pointer which returns the length or indicator value. If the argument is the null pointer, the length and indicator values are not returned, and an error occurs when fetching NULL data.

SQLGetData can return SQL\_NO\_TOTAL, SQL\_NULL\_DATA, and the data length which can be returned to the length/indicator buffer.

**Returns**

SQL\_SUCCESS, SQL\_SUCCESS\_WITH\_INFO, SQL\_NO\_DATA, SQL\_STILL\_EXECUTING, SQL\_ERROR, SQL\_INVALID\_HANDLE

**Diagnosis**

SQLSTATE	Error	Description
01004	String data, right truncated	All data for the column specified as Col_or_Param_Num can not be retrieved by a single function call. The length of the remaining data in the specified column is returned to *StrLen_or_IndPtr before calling SQL_NO_TOTAL or SQLGetData. (The function returns SQL_SUCCESS_WITH_INFO.)
01S07	Fractional truncation	The data returned for one or more column is truncated. For numeric data types, the decimal place is truncated. For time, timestamp, interval data types which contain the period component, the decimal place of time is truncated. (The function returns SQL_SUCCESS_WITH_INFO.)
07006	Restricted data type attribute violation	The column data value in the result set can not be converted to the C data type specified by TargetType.
	Invalid descriptor	Col_or_Param_Num argument value is bigger than the number of columns i

SQLSTATE	Error	Description
07009	index	n the result set.
08S01	Communication link failure	Before the function processing is completed, the connection between the driver and the data source is failed.
22002	Indicator variable required but not supplied	StrLen_or_IndPtr is the null pointer, and the returned data is NULL.
22003	Numeric value out of range	The integer part (not the decimal place) of the numerical value returned from one or more columns is truncated.
22007	Invalid datetime format	The string in the result set is not the valid date, time, timestamp format.
22012	Division by zero	The result of the arithmetic expression divided by 0 is returned.
22015	Interval field overflow	When the interval C type is specified in the exact numeric or interval SQL data type, the significant figures in the leading field is lost. The value of SQL type can not be expressed to C interval type.
22018	Invalid character value for cast specification	The character not represented as the character set of C buffer is included in the character column of the result set. The C type is the exact or approximate numeric, datetime, interval data type, and if the SQL type is the character data type, the value of the column bound to the C type is not valid.
24000	Invalid cursor state	The function is called without calling SQLFetch or SQLFetchScroll. StatementHandle is executed but result set related to StatementHandle does not exist.  The cursor is open by calling SQLFetch or SQLFetchScroll, but the cursor is pointing to before the start or after the end of result set.
HY000	General error	It is an error without any specific SQLSTATE.
HY001	Memory allocation error	It is a memory allocation error.
HY003	Program type out of range	TargetType argument value is not valid.
HY009	Invalid use of null pointer	TargetValuePtr argument is the null pointer.
HY010	Function sequence error	The specified StatementHandle is not in executed state. The function is called without calling SQLExecDirect, SQLExecute, the catalog function.  After calling SQLExecute, SQLExecDirect, then SQL_NEED_DATA is returned and the function is called before sending all data-at-execution variables.
HY090	Invalid string or buffer length	BufferLength argument value is smaller than 0.

## Description

SQLGetData returns the data of the specified column, and it can be called only after one or more rows are fetched from the result set of SQLFetch or SQLFetchScroll. When the variable length data is too large to be returned with a single call SQLGetData (because of application restrictions), SQLGetData can partially retrieve it.

## Using SQLGetData

If TargetType argument is the interval data type, the default value is interval leading precision(2), interval seconds precision(6), and it is set to SQL\_DESC\_DATETIME\_INTERVAL\_PRECISION field and SQL\_DESC\_PRECISION field of ARD each. If TargetType argument is the SQL\_C\_NUMERIC data type, the default value is precision(38), scale(0), and it is set to SQL\_DESC\_PRECISION field and SQL\_DESC\_SCALE field of ARD each. If the default precision and scale are not appropriate, the application should explicitly set the descriptor field by calling SQLSetDescField or SQLSetDescRec.

## Partial Retrieving of Variable Length Data

SQLGetData can partially retrieve the variable length data whose SQL data type is SQL\_CHAR, SQL\_VARCHAR, SQL\_LONGVARCHAR, SQL\_WCHAR, SQL\_WVARCHAR, SQL\_WLONGVARCHAR, SQL\_BINARY, SQL\_VARBINARY, SQL\_LONGVARBINARY.

The application continuously calls SQLGetData multiple times for the same column to partially retrieve the data of the column. SQLGetData returns the next part of the data at each call. The applications should reassemble the parts, being careful to remove the null-termination character in the middle of the character data. If more data should be returned, SQLGetData returns SQL\_SUCCESS\_WITH\_INFO, SQLSTATE 01004 (Data truncated). If the last part of data is returned, SQL\_SUCCESS is returned.

SQLGetData can not be used for returning the part of fixed length data. If SQLGetData is called once or more for a column which contains the fixed-length data, SQL\_NO\_DATA is returned after the first call.

## Retrieving Data Using SQLGetData

SQLGetData performs the following processes to return the data for the specified column.

1. If all data is returned to the column, SQL\_NO\_DATA is returned.
2. If the data is NULL, \*StrLen\_or\_IndPtr is set to SQL\_NULL\_DATA. If the data is NULL and \*StrLen\_or\_IndPtr is the null pointer, SQLGetData returns SQLSTATE 22002 (Indicator variable required but not supplied).

If the column data is not NULL, SQLGetData performs the third process.

3. If the attribute of SQL\_ATTR\_MAX\_LENGTH statement is set to non-zero value or the column contains the string or binary data or SQLGetData is not called for the column before, then the data is truncated to length of SQL\_ATTR\_MAXLENGTH bytes.





The attribute of SQL\_ATTR\_MAX\_LENGTH statement is used to reduce the network traffic. It is generally implemented by the data source, and it truncates the data before returning the data via the network. The driver and the data source are not required to support it. Therefore, the application should allocate a buffer of the proper size, and specify the size of BufferLength argument to guarantee that the data is truncated to the specific size.

4. The data is converted to the data type specified in TargetType. The default precision and scale values for the data type are given to the data. If TargetType is SQL\_ARD\_TYPE, the data type in SQL\_DESC\_CONCISE\_TYPE field of ARD is used. The data provides the precision and scale of SQL\_DESC\_DATETIME\_INTERVAL\_PRECISION field, SQL\_DESC\_PRECISION field, SQL\_DESC\_SCALE field of ARD depending on the data type of SQL\_DESC\_CONCISE\_TYPE field. If all default precisions and scales are not appropriate, the application should explicitly set the descriptor field by calling SQLSetDescField or SQLSetDescRec.
5. If the data is converted to the variable length data type such as the string or binary, SQLGetData checks whether the data length exceeds BufferLength (including the null-termination character). If the data length exceeds BufferLength, SQLGetData truncates the data to the length of BufferLength minus the null-termination character. If the binary data length exceeds the data buffer length, SQLGetData truncates it to the length of BufferLength bytes.  
If the null-termination character is not stored in the provided data buffer, SQLGetData returns SQL\_SUCCESS\_WITH\_INFO and SQLSTATE 01004.  
SQLGetData does not truncate the data converted to the fixed length data type. In this case, the length of \*TargetValuePtr is always assumed as the size of the data type.
6. It stores the converted data in \*TargetValuePtr. Be cautious that SQLGetData can not return data out of line.
7. The data length is stored in \*StrLen\_or\_IndPtr. If StrLen\_or\_IndPtr is the null pointer, SQLGetData does not return the length.
  - For the string and binary data, it is the length after conversion and before truncated to BufferLength. If the driver can not check the data length after conversion (it can happen when it is a long data type), it returns SQL\_SUCCESS\_WITH\_INFO, and it sets the length to SQL\_NO\_TOTAL. (The last call of SQLGetData should return the value of data length which is neither 0 nor is SQL\_NO\_TOTAL) If the data is truncated by the attribute of SQL\_ATTR\_MAX\_LENGTH statement, the attribute value is stored in \*StrLen\_or\_IndPtr. It is because the data is designed to be passed on the server before the attribute is converted, and the driver can not know the actual length. When SQLGetData is continuously called multiple times for the same column, this is the data length available at the beginning of the current call. In other words, the length is reduced due to each subsequent calls.
  - For all other data types, this is the data length after conversion. In other words, it is the size of the type to which data is converted.
8. If the data is truncated without loss of the default value (for example, the real number 1.234 is truncated to an integer 1 when converted), or if it is truncated because BufferLength is too small (e.g. the

string "abcdef" is stored in the buffer of 4-byte length) during data conversion, then SQLGetData returns SQLSTATE 01004 (Data truncated) and SQL\_SUCCESS\_WITH\_INFO. If the data is truncated without loss of the default value due to the attribute of SQL\_ATTR\_MAX\_LENGTH statement, SQLGetData returns SQL\_SUCCESS but it does not return SQLSTATE 01004 (Data truncated).

If SQLGetData does not return SQL\_SUCCESS nor SQL\_SUCCESS\_WITH\_INFO (When SQLGetData is called for the bound column) the contents of bound data buffer, and the length/indicator buffer are not defined.

If SQLGetData is continuously called, it retrieves the data from the last column requested. The previous of fset is not valid.

The following is an example.

```
SQLGetData(icol=n), SQLGetData(icol=m), SQLGetData(icol=n)
```

The second call SQLGetData(icol=n) retrieves the data starting from the column n. All offsets of the data are not valid any more due to the previous SQLGetData call.

## SQLGetData and Descriptor

SQLGetData does not directly interact with any descriptor field.

If targetType is SQL\_ARD\_TYPE, the data type of SQL\_DESC\_CONCISE\_TYPE field of ARD is used. If targetType is SQL\_ARD\_TYPE or SQL\_C\_DEFAULT, the precisions and scales of SQL\_DESC\_DATETIME\_INTERVAL\_PRECISION field, SQL\_DESC\_PRECISION field, and SQL\_DESC\_SCALE field of ARD are given according to the data type of SQL\_DESC\_CONCISE\_TYPE field.

# SQLGetDescField

## Conformance

Introduced version: ODBC 3.0

Standards compliance: ISO 92

## Overview

SQLGetDescField returns the current setting or value of a single field of descriptor record.

## Syntax

```
SQLRETURN SQLGetDescField(  
    SQLHDESC      DescriptorHandle,  
    SQLSMALLINT   RecNumber,  
    SQLSMALLINT   FieldIdentifier,  
    SQLPOINTER    ValuePtr,  
    SQLINTEGER    BufferLength,  
    SQLINTEGER *  StringLengthPtr);
```

## Arguments

### DescriptorHandle

[Input] It is the descriptor handle.

### RecNumber

[Input] It is the descriptor record of information which the application tries to find. If FieldIdentifier argument is the header field, RecNumber is ignored. If RecNumber is equal to or less than SQL\_DESC\_COUNT, and the row does not include the data for the column or parameter, SQLGetDescField returns the default value of field.

### FieldIdentifier

[Input] It is the descriptor field to which the value is returned.

### ValuePtr

[Output] It is the buffer pointer which returns the descriptor information. The data type is dependent on the value of FieldIdentifier.

If ValuePtr is the integer type, the application should use SQLULEN buffer initialized to 0.

If ValuePtr is null, StringLengthPtr returns the number of the total returnable bytes (excluding null-

termination character).

### BufferLength

[Input] If FieldIdentifier field is defined in ODBC and ValuePtr points to the string or binary buffer, the argument should be the length of \*ValuePtr. If FieldIdentifier field is defined in ODBC and \*ValuePtr is an integer, the argument is ignored.

### StringLengthPtr

[Output] It is the pointer which returns the number of the total returnable bytes from \*ValuePtr (excluding null-termination byte for the character data).

## Returns

SQL\_SUCCESS, SQL\_SUCCESS\_WITH\_INFO, SQL\_ERROR, SQL\_NO\_DATA, SQL\_INVALID\_HANDLE

If RecNumber is bigger than the number of current descriptor records, SQL\_NO\_DATA is returned.

If DescriptorHandle is IRD handle and the statement is in the ready state or executing state but associated cursor does not exist, SQL\_NO\_DATA is returned.

## Diagnosis

SQLSTATE	Error	Description
01000	General Warning	It is the driver-specific informational message. (The function returns SQL_SUCCESS_WITH_INFO.)
01004	String data, right truncated	The buffer length of *ValuePtr is shorter than the value length of descriptor field, so it is truncated. The remaining length of descriptor field is returned in *StringLengthPtr. (The function returns SQL_SUCCESS_WITH_INFO.)
07009	Invalid descriptor index	RecNumber argument is set to 0, and the status attribute of SQL_ATTR_USE_BOOKMARKS is set to SQL_UB_OFF, and DescriptorHandle argument is a IRD handle. FieldIdentifier argument is the record field, RecNumber argument is 0, and DescriptorHandle argument is a IPD handle. RecNumber argument is smaller than 0.
08S01	Communication link failure	Before the function processing is completed, the connection between the driver and the data source is failed.
HY000	General error	It is an error without any specific SQLSTATE.
HY001	Memory allocation error	It is a memory allocation error.
HY007	Associated statement is not prepared	DescriptorHandle is related to a IRD handle, and the related handle is not in the preparation state or executing state.
		It is the DescriptorHandle related to StatementHandle for the asynchronous performance function which is still being executed while it is called.

SQLSTATE	Error	Description
HY010	Function sequence error	It is the DescriptorHandle related to StatementHandle which SQLExecute, SQLExecDirect, SQLBulkOperations, SQLSetPos are called and SQL_NEED_DATA is returned.  The asynchronously executing function is called for the connection handle related to DescriptorHandle, and it is still being executed even when SQLGetDescField is called.
HY013	Memory management error	The size of buffer used as an argument is smaller than 0, or it can not access the memory.
HY021	Inconsistent descriptor information	SQL_DESC_TYPE and SQL_DESC_DATETIME_INTERVAL_CODE field are not the valid format for ODBC SQL type, SQL type of the specific driver (for IPD) or ODBC C type (for APD or ARD).
HY090	Invalid string or buffer length	*Valueptr is the string, and BufferLength is smaller than 0.
HY091	Invalid descriptor field Identifier	FieldIdentifier is not the field defined in ODBC, and it is not the implemented value. FieldIdentifier is not defined for DescriptorHandle.
HY117	Connection is suspended due to unknown transaction state. Only disconnect and read-only functions are allowed.	For more information about the suspended state, refer to <a href="#">SQLEndTran</a> .
HYT01	Connection timeout expired	The connection is expired before the data source responds to the request. The time limit can be set via SQL_ATTR_CONNECTION_TIMEOUT of SQLSetStmtAttr.
IM001	Driver does not support this function	The driver related to DescriptorHandle does not support the function.

## Description

The application can call SQLGetDescField to return a single field value of the descriptor record. Calling SQLGetDescField returns the settings for all fields of all descriptor types including the header field, record fields, and bookmarks field. The application can obtain the multiple field settings in an arbitrary order in the same or another descriptor by repeatedly calling SQLGetDescField. SQLGetDescField can be called to return the driver definition descriptor field.

For the performance reason, the application should not call SQLGetDescField for IRD before executing the statement.

Multiple field settings for the size of name, data type, column or parameter data can be retrieved by calling SQLGetDescRec once. SQLGetStmtAttr can be called to return a single field settings in the descriptor header.

ader which is the statement attribute. `SQLColAttribute`, `SQLDescribeCol`, `SQLDescribeParam` return the records or book mark fields.

When the application calls `SQLGetDescField` to retrieve the undefined field value for a particular descriptor type, the function returns `SQL_SUCCESS` but the returned field value is not defined. For example, calling `SQLGetDescField` for `SQL_DESC_NAME` field of APD/ARD or calling `SQLGetDescField` for `SQL_DESC_NULLABLE` field returns `SQL_SUCCESS`, but the field value is not defined.

When the application calls `SQLGetDescField` to retrieve the field value whose particular descriptor is defined but any settings such as default value are not defined, then the function returns `SQL_SUCCESS` but the returned field value is not defined.

## Header Field

Each descriptor consists of the following fields.

### **SQL\_DESC\_ALLOC\_TYPE[All]**

It is the header field which is read-only `SQLSMALLINT`. It specifies whether the descriptor is automatically assigned by the driver or it is explicitly assigned by the application. The application can read the field but can not modify it. When the descriptor is automatically allocated by the driver, the field is set to `SQL_DESC_ALLOC_AUTO` by the driver.

### **SQL\_DESC\_ARRAY\_SIZE[Application descriptors]**

It is the header field which is `SQLULEN` in ARD. It specifies the number of rows in the row set. This is the number of rows returned by the operation caused by calling `SQLFetch`, `SQLFetchScroll`, `SQLBulkOperations` or `SQLSetPos`.

It is the header field which is `SQLULEN` in APD. It specifies the number of values of each parameter. The default value of the field is 1. If `SQL_DESC_ARRAY_SIZE` is bigger than 1, `SQL_DESC_DATA_PTR`, `SQL_DESC_INDICATOR_PTR`, `SQL_DESC_OCTET_LENGTH_PTR` of APD or ARD points to the array. The constant of each array is equal to the field value.

This field in ARD can be set by calling `SQLSetStmtAttr` together with `SQL_ATTR_ROW_ARRAY_SIZE` attribute. The field in APD can also be set by calling `SQLSetStmtAttr` together with `SQL_ATTR_PARAMETER_ARRAY_SIZE`.

### **SQL\_DESC\_ARRAY\_STATUS\_PTR[All]**

For each descriptor type, the header field which is `SQLUSMALLINT*` points to the array of `SQLUSMALLINT` value. The arrays are named as row status array (IRD), parameter status array (IPD), row operation array (ARD), parameter operation array (APD).

This header field in IRD points to the row status array which contains the status value after calling `SQLBulkOperations`, `SQLFetch`, `SQLFetchScroll`, or `SQLSetPos`. The application allocates `SQLUSMALLINT` array, and this field should point to the array. The field is generally the NULL pointer. The driver will create an array unless `SQL_DESC_ARRAY_STATUS_PTR` is set to the NULL pointer.



If the application sets the elements of row status array pointed by `SQL_DESC_ARRAY_STATUS_PTR` field of IRD, then the operation of driver is not defined.

The array is initialized and created by calling `SQLBulkOperations`, `SQLFetch`, `SQLFetchScroll` or `SQLSetPos`. If this call does not return `SQL_SUCCESS` or `SQL_SUCCESS_WITH_INFO`, then the content of array pointed by the field is not defined.

Elements in the array can contain the following values.

- `SQL_ROW_SUCCESS`: The row is successfully retrieved, and it is not updated since the last retrieving.
- `SQL_ROW_SUCCESS_WITH_INFO`: The row is successfully retrieved, and it is not updated since the last return. However, the warning for the row is returned.
- `SQL_ROW_ERROR`: An error occurs during retrieving the row.
- `SQL_ROW_UPDATED`: The row is successfully retrieved, and it is updated since the last retrieving. If the row is retrieved again, the state is `SQL_ROW_SUCCESS`.
- `SQL_ROW_DELETED`: The row is deleted since the last retrieving.
- `SQL_ROW_ADDED`: The row is entered by `SQLBulkOperations`. If the row is retrieved again, the state is `SQL_ROW_SUCCESS`.
- `SQL_ROW_NOROW`: The row set and the last of result set are overlapped. And a row is not returned corresponding to the elements of row status array.

This field of IRD can be set by calling `SQLSetStmtAttr` together with `SQL_ATTR_ROW_STATUS_PTR` attribute.

`SQL_DESC_ARRAY_STATUS_PTR` field of IRD is valid only after `SQL_SUCCESS` or `SQL_SUCCESS_WITH_INFO` is returned. If the return code is not one of these, the thing pointed by `SQL_DESC_ROWS_PROCESSED_PTR` is not defined.

This header field in IPD calls `SQLExecute` or `SQLExecDirect` and then points to the parameter status array which includes each parameter status information. If `SQLExecute` or `SQLExecDirect` is called and `SQL_SUCCESS` or `SQL_SUCCESS_WITH_INFO` is not returned, then the content of array pointed by this field is not defined. The application allocates `SQLUSMALLINT` array, and this field should point the array. The driver will create an array if `SQL_DESC_ARRAY_STATUS_PTR` field is not set to the NULL pointer.

Elements in the array can contain the following values.

- `SQL_PARAM_SUCCESS`: SQL statement was successfully executed for this parameter set.
- `SQL_PARAM_SUCCESS_WITH_INFO`: SQL statement was successfully executed for this parameter set, but there is a warning information available to the diagnostic data structure.
- `SQL_PARAM_ERROR`: An error occurred when processing the parameter set. Additional error information is in the diagnostic data structure.
- `SQL_PARAM_UNUSED`: An error occurred while processing some previous parameters, or it is not used because `SQL_PARAM_IGNORE` is set in the parameter set of the array pointed by `SQL_DESC_ARRAY_STATUS_PTR`.

Y\_STATUS\_PTR field of APD.

- SQL\_PARAM\_DIAG\_UNAVAILABLE: The diagnostic information can not be used. For example, the driver treats the array of the parameter as one and does not generate the level of the error information.

This field in IPD can be set by calling SQLSetStmtAttr together with SQL\_ATTR\_PARAM\_STATUS\_PTR attribute.

In ARD, the corresponding field points to the row operation array for the values set by the application to determine whether or not to ignore the row in SQLSetPos operation.

Elements in the array can contain the following values.

- SQL\_ROW\_PROCEED: The row is included in the bulk operation which uses SQLSetPos. (This setting does not guarantee that the operation occurs on the row. If the row has SQL\_ROW\_ERROR state of the row status array of IRD, the driver can not implement the operation for the row.)
- SQL\_ROW\_IGNORE: The row is excluded from the bulk operation which uses SQLSetPos.

If elements of the array is not set, all rows are included in the bulk operation. If the value of SQL\_DESC\_ARRAY\_STATUS\_PTR field of ARD is the NULL pointer, all rows are included in the bulk operation. It is translated as same as when the pointer points to a valid array and all elements of the array are SQL\_ROW\_PROCEED. When all elements in the array are set to SQL\_ROW\_IGNORE, the values in the row status array for the ignored rows are not updated.

This field in ARD can also be set by calling SQLSetStmtAttr together with SQL\_ATTR\_ROW\_OPERATION\_PTR attribute.

When SQLExecute or SQLExecDirect is called, this header field in ARD points to the parameter operation array of the values set by the application to indicate whether or not to ignore the parameter set.

Elements in the array can contain the following values.

- SQL\_PARAM\_PROCEED: The parameter set is included in calling SQLExecute or SQLExecDirect.
- SQL\_PARAM\_IGNORE: The parameter set is not included in calling SQLExecute or SQLExecDirect.

If elements of the array are not set, all parameter sets of the array are used to call SQLExecute or SQLExecDirect. If the value of SQL\_DESC\_ARRAY\_STATUS\_PTR field of APD is the NULL pointer, all parameter set are used. It is read as same as when the pointer points to the valid array, or the array whose all elements are SQL\_PARAM\_PROCEED.

This field in APD can also be set by calling SQLSetStmtAttr together with SQL\_ATTR\_PARAM\_OPERATION\_PTR attribute.

### **SQL\_DESC\_BIND\_OFFSET\_PTR[Application descriptors]**

This header field is SQLLEN\* and it points to the binding offset. It is set to the NULL pointer by default. If this field is not the NULL pointer, the driver dereferences the pointer and each value of the d



ferred field which has non-NULL value of the descriptor record (SQL\_DESC\_DATA\_PTR\_, SQL\_DESC\_INDICATOR\_PTR and SQL\_DESC\_OCTET\_LENGTH\_PTR) at fetching time, and uses a new pointer value when binding.

The binding offset is always directly added to SQL\_DESC\_DATA\_PTR field, SQL\_DESC\_INDICATOR\_PTR field and SQL\_DESC\_OCTET\_LENGTH\_PTR field. If the offset value is changed to another value, the new value is directly and continuously added as each descriptor field value. The new offset is not added to the previous offset value of the field.

It is the deferred field. This field is not used at the time of setting, but it is used by the driver when the data buffer address is checked.

This field in ARD can be set by calling SQLSetStmtAttr together with SQL\_ATTR\_ROW\_BIND\_OFFSET\_PTR attribute.

For more information, refer to **SQLFetchScroll** or **SQLBindParameter**.

### SQL\_DESC\_BIND\_TYPE[Application descriptors]

This header field is SQLINTEGER and is used to set the binding direction.

This field in ARD specifies the binding direction when SQLFetchScroll or SQLFetch is called on the related statement handle.

This field can be set to SQL\_BIND\_BY\_COLUMN(default) to select the column-wise binding for the columns.

The field in ARD can be set by calling SQLSetStmtAttr together with SQL\_ATTR\_ROW\_BIND\_TYPE attribute.

The field specifies the binding direction used in the dynamic parameter.

This field may be set to SQL\_BIND\_BY\_COLUMN(default) to select the column-wise binding for the parameter.

This field can be set by calling SQLSetStmtAttr together with SQL\_ATTR\_PARAM\_BIND\_TYPE attribute.

### SQL\_DESC\_COUNT[AII]

This header field is SQLSMALLINT and specifies the 1-based index of the top-level record which includes the data. When the driver sets the data structure to the descriptor, SQL\_DESC\_COUNT should be set to display the number of important records. It is not required to specify how many space to reserve for the record when the application allocates instances of data structure. Like as the application specifies the contents of the records, the driver performs the requested operation for the descriptor handle to guarantee displaying the sufficient size of the data structure.

It is not the number of all data column or all parameters which SQL\_DESC\_COUNT is bound to, but it is the number of top-level records. If the binding of the top-level column or parameter is released, SQL\_DESC\_COUNT is changed to the number of next top-level columns or parameters. If the binding of the top-level column, the column which is smaller than the parameter, or parameters is released (if TargetValuePtr argument is set to the NULL pointer, and SQLBindCol is called, or if Paramete

rValuePtr argument is set to the NULL pointer and SQLBindParameter is called), SQL\_DESC\_COUNT is not changed. If the added column or parameter is bound with bigger number than the number of top level records which includes the data, the driver automatically increases the value of SQL\_DESC\_COUNT field. If the binding for all columns is released by calling SQLFreeStmt with the SQL\_UNBIND option, SQL\_DESC\_COUNT in ARD and IRD is set to 0. If SQLFreeStmt is called with the SQL\_RESET\_PARAMS option, SQL\_DESC\_COUNT fields in APD and IPD is set to 0.

The value of SQL\_DESC\_COUNT is explicitly set by calling SQLSetDescField in the application. If the value of SQL\_DESC\_COUNT is explicitly decreased, the records which have the value bigger than the new value of SQL\_DESC\_COUNT are effectively removed. If the value of SQL\_DESC\_COUNT field of ARD is set to 0, all buffers are released except for the bound bookmark column. The number of records of the field Of ARD does not include the bound bookmark column. The only way to release the binding of book mark column is to set SQL\_DESC\_DATA\_PTR to NULL pointer.

### **SQL\_DESC\_ROWS\_PROCESSED\_PTR[Implementation descriptors]**

This header field is SQLULEN\* of IRD, and points to the buffer. The buffer includes the number of rows returned after calling SQLFetch or SQLFetchScroll, and the number of rows or number of errors affected by calling SQLBulkOperations or SQLSetPos and executing the bulk operation.

This header field is SQLINTEGER\* of IPD and points to the buffer which includes the processed parameter set or the number of errors. If it is NULL pointer, the number is not returned.

SQL\_DESC\_ROWS\_PROCESSED\_PTR is valid only after calling SQLFetch or SQLFetchScroll(IRD) or after SQL\_SUCCESS or SQL\_SUCCESS\_WITH\_INFO is returned by calling SQLExecute, SQLExecDirect or SQLParamData(IPD). If the functions above do not return SQL\_SUCCESS or SQL\_SUCCESS\_WITH\_INFO, then the buffer contents are not defined and the buffer value is set to 0 until SQL\_NO\_DATA is returned.

The field in ARD can be set by calling SQLSetStmtAttr together with SQL\_ATTR\_ROWS\_FETCHED\_PTR attribute. ARD can be set by calling SQL\_ATTR\_PARAMS\_PROCESSED\_PTR.

The buffer pointed by this field is allocated by the application. It is the deferred output buffer defined by the driver. NULL pointer is set by default.

## **Record Field**

Each descriptor includes one or more records consisting of the fields which define the column data or dynamic parameter depending on the descriptor type. Each record is a complete specification of a single column or parameter.

### **SQL\_DESC\_AUTO\_UNIQUE\_VALUE[IRDs]**

This record field is read-only SQLINTEGER. It is SQL\_TRUE if the column is automatically increased. Otherwise, it is SQL\_FALSE. The auto-increment column does not need to be read-only.

### **SQL\_DESC\_BASE\_COLUMN\_NAME[IRDs]**

This record field is read-only SQLCHAR\*. It includes the default column name of the result set column. If the default column name does not exist, the field should include an empty string.

**SQL\_DESC\_TABLE\_NAME[IRDs]**

This record field is read-only SQLCHAR\*. It includes the base table name of the result set column. If the base table name is not defined or used, the field should include an empty string.

**SQL\_DESC\_CASE\_SENSITIVE[Implementation descriptors]**

This record field is read-only SQLINTEGER. It includes SQL\_TRUE if the column or parameter is case-sensitive when sorting or comparing columns or parameters, but it includes SQL\_FALSE if the column or parameter is case-insensitive or non-character column.

**SQL\_DESC\_CATALOG\_NAME[IRDs]**

This record field that is read-only SQLCHAR\*. It includes the catalog of the base table which includes the column. If the column is an expression or a part of a view, the return value is dependent on the driver. If the data source does not support the catalog nor does it check the catalog, the field should include an empty string.

**SQL\_DESC\_CONCISE\_TYPE[AII]**

This header field is SQLSMALLINT. It specifies the simple format for the data types which includes datetime and interval data types.

The value of SQL\_DESC\_CONCISE\_TYPE field, SQL\_DESC\_TYPE field and SQL\_DESC\_DATETIME\_INTERVAL\_CODE field are interdependent. If time is set in one of the fields, it should be set on other fields as well. SQL\_DESC\_CONCISE\_TYPE can be set by calling SQLBindCol, SQLBindParameter or SQLSetDescField. SQL\_DESC\_TYPE is set by calling SQLSetDescField or SQLSetDescRec.

If SQL\_DESC\_CONCISE\_TYPE is set as the simple data types except for the interval or datetime data type, then SQL\_DESC\_TYPE field is set to the same value, and SQL\_DESC\_DATETIME\_INTERVAL\_CODE field is set to 0.

If SQL\_DESC\_CONCISE\_TYPE is set as the simple datetime or interval data type, then SQL\_DESC\_TYPE field is set to the detailed type(SQL\_DATETIME or SQL\_INTERVAL), and SQL\_DESC\_DATETIME\_INTERVAL\_CODE field is set to the proper subcode.

**SQL\_DESC\_DATETIME\_INTERVAL\_CODE[AII]**

This record field is SQLSMALLINT. It includes the subcode which specifies the datetime or interval data type when SQL\_DESC\_TYPE field is SQL\_DATETIME or SQL\_INTERVAL. It is the same for both SQL and C support it, the code includes the data type name such as "TYPE" or "C\_TYPE" for datetime type, "CODE" replaced from "INTERVAL" or "C\_INTERVAL" for interval types.

If SQL\_DESC\_TYPE and SQL\_DESC\_CONCISE\_TYPE of the application descriptor are set to SQL\_C\_DEFAULT and the descriptor is not related to the statement handle, then the content of SQL\_DESC\_DATETIME\_INTERVAL\_CODE is not defined.

This field can set the datetime data types listed in the following table.

Datetime type	DATETIME_INTERVAL_CODE
SQL_TYPE_DATE SQL_C_TYPE_DATE	SQL_CODE_DATE

Datetime type	DATETIME_INTERVAL_CODE
SQL_TYPE_TIME SQL_C_TYPE_TIME	SQL_CODE_TIME
SQL_TYPE_TIMESTAMP SQL_C_TYPE_TIMESTAMP	SQL_CODE_TIMESTAMP

This field can set the interval data types listed in the following table.

Interval type	DATETIME_INTERVAL_CODE
SQL_INTERVAL_DAY SQL_C_INTERVAL_DAY	SQL_CODE_DAY
SQL_INTERVAL_DAY_TO_HOUR SQL_C_INTERVAL_DAY_TO_HOUR	SQL_CODE_DAY_TO_HOUR
SQL_INTERVAL_DAY_TO_MINUTE SQL_C_INTERVAL_DAY_TO_MINUTE	SQL_CODE_DAY_TO_MINUTE
SQL_INTERVAL_DAY_TO_SECOND SQL_C_INTERVAL_DAY_TO_SECOND	SQL_CODE_DAY_TO_SECOND
SQL_INTERVAL_HOUR SQL_C_INTERVAL_HOUR	SQL_CODE_HOUR
SQL_INTERVAL_HOUR_TO_MINUTE SQL_C_INTERVAL_HOUR_TO_MINUTE	SQL_CODE_HOUR_TO_MINUTE
SQL_INTERVAL_HOUR_TO_SECOND SQL_C_INTERVAL_HOUR_TO_SECOND	SQL_CODE_HOUR_TO_SECOND
SQL_INTERVAL_MINUTE SQL_C_INTERVAL_MINUTE	SQL_CODE_MINUTE
SQL_INTERVAL_MINUTE_TO_SECOND SQL_C_INTERVAL_MINUTE_TO_SECOND	SQL_CODE_MONUTE_TO_SECOND
SQL_INTERVAL_MONTH SQL_C_INTERVAL_MONTH	SQL_CODE_MONTH
SQL_INTERVAL_SECOND SQL_C_INTERVAL_SECOND	SQL_CODE_SECOND
SQL_INTERVAL_YEAR SQL_C_INTERVAL_YEAR	SQL_CODE_YEAR
SQL_INTERVAL_YEAR_TO_MONTH SQL_C_INTERVAL_YEAR_TO_MONTH	SQL_CODE_YEAR_TO_MONTH

### SQL\_DESC\_DATETIME\_INTERVAL\_PRECISION[All]

This SQLINTEGER record field includes the interval leading precision if SQL\_DESC\_TYPE field is SQL\_INTERVAL. When SQL\_DESC\_DATETIME\_INTERVAL\_CODE field is set to the interval data type, the field sets the default interval leading precision.

**SQL\_DESC\_DISPLAY\_SIZE[IRDs]**

This read-only SQLINTEGER record field contains the maximum number of characters required to show the data from the column.

**SQL\_DESC\_FIXED\_PREC\_SCALE[Implementation descriptors]**

This read-only SQLSMALLINT record field sets SQL\_TRUE if the column is the exact numeric column and it has non-zero scale and the fixed precision. Otherwise, it sets SQL\_FALSE.

**SQL\_DESC\_INDICATOR\_PTR[Application descriptors]**

This SQLLEN\* record field in ARD represents the indicator variable. The variable includes SQL\_NULL\_DATE if the column value is NULL. For APD, the indicator variable is set to SQL\_NULL\_DATA to specify a dynamic factor as NULL, otherwise the variable is zero.

If SQL\_DESC\_INDICATOR\_PTR field of ARD is NULL pointer, the driver prevents the information returned for whether the column is NULL. If the column is NULL and SQL\_DESC\_INDICATOR\_PTR is NULL pointer, SQLSTATE 22002(Indicator variable required but not supplied) is returned when the driver creates the buffer after calling SQLFetch or SQLFetchScroll. If calling SQLFetch or SQLFetchScroll does not return SQL\_SUCCESS or SQL\_SUCCESS\_WITH\_INFO, the buffer content is not defined.

SQL\_DESC\_INDICATOR\_PTR field determines whether to set the field represented by SQL\_DESC\_OCTET\_LENGTH\_PTR. If the column value is NULL, the driver sets the indicator variable to SQL\_NULL\_DATA. The field represented by SQL\_DESC\_OCTET\_LENGTH\_PTR is not set at that moment. If NULL is not returned while retrieving the data, the buffer represented by SQL\_DESC\_INDICATOR\_PTR is set to 0, and the buffer represented by SQL\_DESC\_OCTET\_LENGTH\_PTR sets the data length.

If SQL\_DESC\_INDICATOR\_PTR field of APD is NULL pointer, the application can not use the descriptor record to specify the argument as NULL.

This field is the deferred field. It is not used when the driver is set, but it is used when the driver displays NULL possibility (ARD) or determines the NULL possibility (APD).

**SQL\_DESC\_LABEL[IRDs]**

This read-only SQLCHAR\* record field includes the label or mark of a column. If the column does not have label, then the variable contains the column name. If the column is not named or it can not use the label, then the variable includes an empty string.

**SQL\_DESC\_LENGTH[AII]**

This SQLULEN record field is the maximum length or actual length of the string or binary data in bytes. It is the maximum length of fixed length data type data or the actual length of variable length data type data. The value always excludes NULL termination character at the end of string. If its data type is SQL\_TYPE\_DATE, SQL\_TYPE\_TIME, SQL\_TYPE\_TIMESTAMP or SQL interval data type, the field has the string length of when datetime or interval value is rewritten to string.

The field value is different from the value of "length" defined in ODBC 2.x.

**SQL\_DESC\_LITERAL\_PREFIX[IRDs]**

This read-only SQLCHAR\* record field includes the characters recognized as a suffix by the character or the driver. The variable contains the empty string for the data type whose character suffix can

not be converted.

#### **SQL\_DESC\_LOCAL\_TYPE\_NAME[Implementation descriptors]**

This read-only SQLCHAR\* record field includes the localized name in the data type, and it could be different from the regular name in the data type. If the localized name does not exist, an empty string is returned. The field is only for the purpose of displaying.

#### **SQL\_DESC\_NAME[Implementation descriptor]**

This SQLCHAR\* record field includes the field alias in the row descriptor. If the column alias is not applied, the column name is returned. In some cases, the driver sets SQL\_DESC\_UNNAMED field to SQL\_NAMED when setting SQL\_DESC\_NAME field. If neither column name nor column alias exist, the driver returns the empty string of SQL\_DESC\_NAME field, and sets SQL\_DESC\_UNNAME field to SQL\_UNNAMED.

The application can set SQL\_DESC\_NAME field of IPD for an alias to specify the parameter name or stored named procedure parameter. SQL\_DESC\_NAME field of IRD is the read-only field. If the application tries to set this field, SQLSTATE HY091 (invalid descriptor field identifier) will be returned.

For IPD, if the driver does not support the named parameter, the field is not defined. If the driver supports the named parameter and specifies the parameter, the name of the parameter is returned to this field.

#### **SQL\_DESC\_NULLABLE[Implementation descriptors]**

For IRD, this read-only SQLSMALLINT record field is SQL\_NULLABLE if the column has NULL, otherwise it is SQL\_NO\_NULLS. If it is unknown whether the column allows NULL, it is SQL\_NULLABLE\_UNKNOWN. The field exists particularly for the column in the result set.

For IPD, The field is always set to SQL\_NULLABLE because the dynamic parameter can always be NULL and it can not be set by the application.

#### **SQL\_DESC\_NUM\_PREC\_RADIX[AII]**

This SQLINTEGER field has the value of 2 when SQL\_DESC\_TYPE field is the approximate numeric data type. It is because SQL\_DESC\_PRECISION field includes the number of bits. The field has the value of 10 when SQL\_DESC\_TYPE field is the exact numeric data type and SQL\_DESC\_PRECISION contains the number of decimal places. The field sets 0 for a non-numeric data type.

#### **SQL\_DESC\_OCTET\_LENGTH[AII]**

This SQLLEN record field includes the length in bytes of a string or binary data type. For the fixed length character or binary data, it is the actual length in bytes. For the variable length character or binary data, it is the maximum length in bytes. The value does not include the empty string of NULL termination character for the implementation descriptor, and it includes the empty string of NULL termination character for the application descriptor. For the application data, the field contains the buffer size. For APD, the field is defined only for the output or input/output parameters.

#### **SQL\_DESC\_OCTET\_LENGTH\_PTR[Application descriptors]**

The SQLLEN\* record field points to the variable including the total length in bytes of the dynamic argument (parameter descriptor) or the binding column values (row descriptor).

This value is ignored for all arguments excluding the string or binary data in APD. If the field is SQL\_NTS, the dynamic argument should be terminated with NULL. The application sets the variable including the macro result of SQL\_DATA\_AT\_EXEC or SQL\_LEN\_DATA\_AT\_EXEC in this record field of APD to indicate that the bound parameter is to be a data parameter at the run-time. If one or more fields exist, SQL\_DESC\_DATA\_PTR can be set as the value which identifies the parameter required by the application, and which is helpful to determine the parameter.

If OCTET\_LENGTH\_PTR field of ARD is NULL pointer, the driver does not return the column length. If SQL\_DESC\_OCTET\_LENGTH\_PTR of APD is NULL pointer, the driver assumes that the string and binary values are terminated by NULL. (Binary values should not be terminated by NULL, but the length should be given to avoid data interruption.)

If SQLFetch or SQLFetchScroll which fills the buffer pointed by the field does not return SQL\_SUCCESS or SQL\_SUCCESS\_WITH\_INFO, the buffer content is not defined. It is the deferred field. The field is not immediately used, but it is used later when the driver displays or determines the data length in octet.

#### **SQL\_DESC\_PARAMETER\_TYPE[IRDs]**

This SQLSMALLINT record field sets the input parameter to SQL\_PARAM\_INPUT, the input/output parameter to SQL\_PARAM\_INPUT\_OUTPUT, the output parameter to SQL\_PARAM\_OUTPUT, the stream input/output parameter to SQL\_PARAM\_INPUT\_OUTPUT\_STREAM or the stream output parameter to SQL\_PARAM\_OUTPUT\_STREAM. It is set to SQL\_PARAM\_INPUT by default.

#### **SQL\_DESC\_PRECISION[AII]**

This SQLSMALLINT record field includes the number of valid integers for the exact numeric data types, and it includes the number of bits in mantissa (the binary precision) for the approximate numeric data types. Or, it contains the number of valid integer of the fractional seconds parts of the SQL\_TYPE\_TIME, SQL\_TYPE\_TIMESTAMP, or SQL\_INTERVAL\_SECOND data type. The field is not defined for all other data types.

The field value is different from the "precision" value defined in ODBC 2.x.

#### **SQL\_DESC\_ROWVER[Implementation descriptors]**

This SQLSMALLINT record field indicates whether the column is automatically updated by DBMS when the row is updated (for example, "timestamp" in SQL Server). The record field value is set to SQL\_TRUE for the row versioning column, otherwise it is set to SQL\_FALSE. The column attribute is similar to setting and calling SQL\_ROWVER in IdentifierType argument of SQLSpecialColumn to determine whether to automatically update column.

#### **SQL\_DESC\_SCALE[AII]**

This SQLSMALLINT record field includes the number of decimal places defined in the decimal and numeric data types. The field is not defined for all other data types.

The field value is different from the "scale" value defined in ODBC 2.x.

#### **SQL\_DESC\_SCHEMA\_NAME[IRDs]**

This read-only SQLCHAR\* record field includes the schema name of the base table that includes the column. If the column is an expression or a part of the view, the return value is dependent on the

driver. If the data source does not support the schema or can not identify the schema name, then this variable contains an empty string.

#### SQL\_DESC\_SEARCHABLE[IRDS]

This read-only SQLSMALINT record field sets one of the following values.

- If the column can not be used in WHERE clause, it is SQL\_PRED\_NONE. (It is as same as SQL\_UNSEARCHABLE in ODBC 2.X.)
- If the column can only be used with LIKE predicate in WHERE clause, it is SQL\_PRED\_CHAR.
- If the column can be used with all comparison operators except for LIKE in WHERE clause, it is SQL\_PRED\_BASIC. (It is as same as the value of SQL\_EXCEPT\_LIKE in ODBC 2.x.)
- If the column can be used with any comparison operator in WHERE clause, it is SQL\_PRED\_SEARCHABLE.

#### SQL\_DESC\_TABLE\_NAME[IRDS]

This read-only SQLCHAR\* record field includes the base table name which includes column. The return value is dependent on the driver if the column is an expression or a part of the view.

#### SQL\_DESC\_TYPE[AII]

This SQLSMALLINT record field includes an abbreviated SQL data types or C data types for all data types except for the interval and datetime data types. The field specifies SQL\_DATETIME or SQL\_INTERVAL for datetime and interval data types.

Whenever this field includes SQL\_DATETIME or SQL\_INTERVAL, SQL\_DESC\_DATETIME\_INTERVAL\_CODE field should include the appropriate subcode in the implied format. For datetime data types, SQL\_DESC\_TYPE includes SQL\_DATETIME, and SQL\_DESC\_DATETIME\_INTERVAL\_CODE field includes the subcode that specifies the datetime data type. For interval data types, SQL\_DESC\_TYPE includes SQL\_INTERVAL, and SQL\_DESC\_DATETIME\_INTERVAL\_CODE field includes the subcode that specifies the interval data type.

The values of SQL\_DESC\_TYPE and SQL\_DESC\_CONCISE\_TYPE field are interdependent. When one of the fields is set, the other field should also be set. SQL\_DESC\_TYPE can be set by calling SQLSetDescField or SQLSetDescRec. SQL\_DESC\_CONCISE\_TYPE can be set by calling SQLBindCol, SQLBindParameter or SQLSetDescField.

If SQL\_DESC\_TYPE is set to the implied data type other than the interval or datetime data type, SQL\_DESC\_CONCISE\_TYPE field is set to the same value and SQL\_DESC\_DATETIME\_INTERVAL\_CODE is set to 0.

If SQL\_DESC\_TYPE is set to the long data type of datetime or interval data type (SQL\_DATETIME or SQL\_INTERVAL), SQL\_DESC\_DATETIME\_INTERVAL\_CODE field is set to the appropriate subcode, SQL\_DESC\_CONCISE\_TYPE may be set to a value corresponding to the implied data type. If SQL\_DESC\_TYPE is set to one of the implied datetime or interval data type, SQLSTATE HY021 (Inconsistent descriptor information) is returned.

When SQL\_DESC\_TYPE is set by calling SQLBindCol, SQLBindParameter or SQLSetDescField, the next fields are set to the default values in the following table. The values of remaining fields in the sa



me record are not defined.

SQL_DESC_TYPE value	Setting other fields implicitly
SQL_CHAR, SQL_VARCHAR, SQL_C_CHAR, SQL_C_VARCHAR	SQL_DESC_LENGTH is set to 1. SQL_DESC_PRECISION is set to 0.
SQL_DATETIME	If SQL_DESC_DATETIME_INTERVAL_CODE is set to SQL_CODE_DATE or SQL_CODE_TIME, SQL_DESC_PRECISION is set to 0. If SQL_DESC_TIMESTAMP is set, SQL_DESC_PRECISION is set to 6.
SQL_DECIMAL, SQL_NUMERIC, SQL_C_NUMERIC	SQL_DESC_SCALE is set to 0. SQL_DESC_PRECISION is set to the implemented precision of each data type.
SQL_FLOAT, SQL_C_FLOAT	SQL_DESC_PRECISION is set to the default precision implemented in SQL_FLOAT.
SQL_INTERVAL	When SQL_DESC_DATETIME_INTERVAL_CODE is set to the interval data type, SQL_DESC_DATETIME_INTERVAL_PRECISION is set to 2 (default interval leading precision). When the interval has the part of seconds, SQL_DESC_PRECISION is set to 6 (the default interval seconds precision).

When the application sets the descriptor field by calling not `SQLSetDescRec` but `SQLSetDescField`, the application should define the data type firstly. Therefore other fields in the previous table are implicitly set. If it is not allowed to implicitly set any value, the application explicitly sets the value by calling `SQLSetDescField` or `SQLSetDescRec`.

#### **SQL\_DESC\_TYPE\_NAME[Implementation descriptors]**

This read-only `SQLCHAR*` record field includes the data source dependent type name ("CHAR", "VARCHAR", etc.). If the data type name is unknown, the variable includes an empty string.

#### **SQL\_DESC\_UNNAMED[Implementation descriptors]**

If `SQL_DESC_NAME` field is set, the `SQLSMALLINT` record field in the row descriptor is set to one of `SQL_NAME` or `SQL_UNNAMED` by the driver. If `SQL_DESC_NAME` field does not include the column alias or if the column alias does not apply, the driver sets `SQL_DESC_UNNAMED` field to `SQL_UNNAMED`. If the application sets `SQL_DESC_NAME` field of IPD to the parameter name or alias, the driver sets `SQL_DESC_UNNAMED` field of IPD to `SQL_NAMED`. If neither column name nor does alias exist, the driver sets `SQL_DESC_UNNAMED` field of IPD to `SQL_UNNAMED`.

The application sets `SQL_DESC_UNNAMED` field of IPD to `SQL_UNNAMED`. If the application tries to set `SQL_DESC_UNNAMED` field of IPD to `SQL_NAMED`, the driver returns `SQLSTATE HY091` (Invalid descriptor field identifier). `SQLSTATE HY091` (Invalid descriptor field identifier) is returned if the read-only application tries to set `SQL_DESC_UNNAMED` field of IRD.

**SQL\_DESC\_UNSIGNED[Implementation descriptors]**

This read-only SQLSMALLINT record field is set to SQL\_TRUE, if the column type is the unsigned or non-numeric data type. It is set to SQL\_FALSE, if the column type is the signed data type.

**SQL\_DESC\_UPDATABLE[IRDs]**

The read-only SQLSMALLINT record field is set to one of the following values.

- If the result set column is read-only, it is SQL\_ATTR\_READ\_ONLY.
- If the result set column is read and write, it is SQL\_ATTR\_WRITE.
- If the updatability for the result set column is unknown, it is SQL\_ATTR\_READWRITE\_UNKNOWN.

SQL\_DESC\_UPDATABLE explains the updatability of the result set column (the column is not in the base table). The updatability of the column in the primary table which is a base of the result set columns may be different from the value in this field. The updatability is based on the data type, the user privileges and the result set definition. If it is not sure that the column can be updated, SQL\_ATTR\_READWRITE\_UNKNOWN should be returned.

**SQL\_DESC\_CHAR\_LENGTH\_UNITS[AIs]**

This SQLSMALLINT record field indicates the length units of the column whose SQL types are SQL\_CHAR, SQL\_VARCHAR and SQL\_LONGVARCHAR.

- SQL\_CLU\_CHARACTERS: The length unit is CHARACTER. For example, the length of data "문자열" is 3 if the encoding method is UHC(Unified Hangul Code).
- SQL\_CLU\_OCTETS: The length unit is OCTETS. For example, the length of data "문자열" is 6 if the encoding method is UHC(Unified Hangul Code).
- SQL\_CLU\_NONE: The length unit is undefined. It is the value which is returned for the SQL types excluding the SQL types listed above.

# SQLGetDescRec

## Conformance

Introduced version: ODBC 1.0

Standards compliance: ISO 92

## Overview

SQLGetDescRec returns the current value or setting for the multiple fields of the descriptor record. The returned field describes the name, the data type, the column size or the argument data.

## Syntax

```
SQLRETURN SQLGetDescRec(
    SQLHDESC      DescriptorHandle,
    SQLSMALLINT   RecNumber,
    SQLCHAR *     Name,
    SQLSMALLINT   BufferLength,
    SQLSMALLINT * StringLengthPtr,
    SQLSMALLINT * TypePtr,
    SQLSMALLINT * SubTypePtr,
    SQLLEN *      LengthPtr,
    SQLSMALLINT * PrecisionPtr,
    SQLSMALLINT * ScalePtr,
    SQLSMALLINT * NullablePtr);
```

## Arguments

### DescriptorHandle

[Input] It is the descriptor handle.

### RecNumber

[Input] It is the descriptor record of the information which the application wants to retrieve. The record number 0 is set as the bookmark record and the descriptor record starts from 1. If RecNumber is equal to or smaller than SQL\_DESC\_COUNT, but the data for the column or parameter is not included in the row, SQLGetDescField returns the default value of the field.

**Name**

[Output] It is the buffer pointer which returns SQL\_DESC\_NAME for the descriptor record. If Name is NULL, StringLengthPtr returns the buffer length of Name (including null-termination character).

**BufferLength**

[Input] It is the length of name buffer.

**StringLengthPtr**

[Output] It is the pointer which returns the number of characters returnable in \*Name buffer excluding null-termination character. If the number of characters are equal to or bigger than BufferLength, the data of \*Name is truncated to BufferLength minus the length of a null-termination character, and is null-terminated.

**TypePtr**

[Output] It is the buffer pointer which returns the value of SQL\_DESC\_TYPE for the descriptor field.

**SubTypePtr**

[Output] It is the buffer pointer which returns the value of SQL\_DESC\_DATETIME\_INTERVAL\_CODE field for the record of SQL\_DATETIME or SQL\_INTERVAL type.

**LengthPtr**

[Output] It is the buffer pointer which returns the value of SQL\_DESC\_OCTET\_LENGTH field for the descriptor field.

**PrecisionPtr**

[Output] It is the pointer which returns the value of SQL\_DESC\_PRECISION field for the descriptor record.

**ScalePtr**

[Output] It is the pointer which returns the value of SQL\_DESC\_SCALE field for the descriptor record.

**NullablePtr**

[Output] It is the pointer which returns the value of SQL\_DESC\_NULLABLE field for the descriptor record.

**Returns**

SQL\_SUCCESS, SQL\_SUCCESS\_WITH\_INFO, SQL\_ERROR, SQL\_NO\_DATA, SQL\_INVALID\_HANDLE

If RecNumber is bigger than the number of current descriptor records, SQL\_NO\_DATA is returned. If DescriptorHandle is the IRD handle and the statement is on the preparation or execution state but related cursor does not exist, then SQL\_NO\_DATA is returned.

## Diagnosis

SQLSTATE	Error	Description
01000	General Warning	It is a specific information message of the driver. (The function returns SQL_SUCCESS_WITH_INFO.)
01004	String data, right truncated	The length of *ValuePtr buffer is shorter than the length of the descriptor field value, so the length is truncated. The remaining length of the descriptor field is returned to *StringLengthPtr. (The function returns SQL_SUCCESS_WITH_INFO.)
07009	Invalid descriptor index	The fieldIdentifier argument is the record field, and the value of RecNumber argument is set to 0, and DescriptorHandle argument is the IPD handle. RecNumber argument is set to 0, and SQL_ATTR_USE_BOOKMARKS attribute is set to SQL_UB_OFF, and DescriptorHandle argument is the IRD handle. RecNumber argument is smaller than 0.
08S01	Communication link failure	Before the function processing is completed, the connection between the driver and the data source is failed.
HY000	General error	It is an error without any specific SQLSTATE.
HY001	Memory allocation error	It is a memory allocation error.
HY007	Associated statement is not prepared	DescriptorHandle is related to the IRD handle, and the related statement handle is not on the preparation or execution state.
HY010	Function sequence error	StatementHandle related to DescriptorHandle asynchronously executes the function and it is still executing the function when called. After calling SQLExecute, SQLExecDirect, then SQL_NEED_DATA is returned and the function is called before sending all data-at-execution variables. The function for the connection handle related to DescriptorHandle is called, and it is still executing when SQLGetDescRec is called.
HY013	Memory management error	The buffer size used as the argument is smaller than 0, or it can not access the memory.
HY117	Connection is suspended due to unknown transaction state. Only disconnect and read-only functions are allowed.	For more information about the suspended state, refer to <b>SQLEndTran</b> function.
HYT01	Connection timeout expired	The connection is expired before the data source responds to the request. The timeout can be set via SQL_ATTR_CONNECTION_TIMEOUT of SQLSetStmtAttr.
IM001	Driver does not support this function	The driver related to DescriptorHandle does not support the function.

## Description

The application can call `SQLGetDescRec` to retrieve the following descriptor field value for a column or parameter.

- `SQL_DESC_NAME`
- `SQL_DESC_TYPE`
- `SQL_DESC_DATETIME_INTERVAL_CODE`
- `SQL_DESC_OCTET_LENGTH`
- `SQL_DESC_PRECISION`
- `SQL_DESC_SCALE`
- `SQL_DESC_NULLABLE`

`SQLGetDescRec` does not retrieve the header field value.

The application can set the argument corresponding to the null pointer field so that it prevents the return for the field setting.

When the application retrieves the value of the undefined field for the specific descriptor type by calling `SQLGetDescRec`, the function returns `SQL_SUCCESS`, but the return value for the field is not defined. For example, if `SQLGetDescRec` is called for `SQL_DESC_NAME` field or `SQL_DESC_NULLABLE` field of APD or ARD, then `SQL_SUCCESS` is returned but the field value is not defined.

When the application calls `SQLGetDescRec` to retrieve the value of the field which is defined as the specific descriptor type but is not set as the default, the function returns `SQL_SUCCESS`, but the field value is not defined. For more information, refer to **Initializing Descriptor Field** of `SQLSetDescField`.

Each field value can be retrieved separately by calling `SQLGetDescField`. For more information about the descriptor header or the fields in the record, refer to **SQLSetDescField**.

# SQLGetDiagField

## Conformance

Introduced version: ODBC 3.0

Standards compliance: ISO 92

## Overview

SQLGetDiagField returns the current value of the record fields in the diagnostic data structure which contains an error, warning, and status information.

## Syntax

```
SQLRETURN SQLGetDiagField(  
    SQLSMALLINT    HandleType,  
    SQLHANDLE      Handle,  
    SQLSMALLINT    RecNumber,  
    SQLSMALLINT    DiagIdentifier,  
    SQLPOINTER     DiagInfoPtr,  
    SQLSMALLINT    BufferLength,  
    SQLSMALLINT *  StringLengthPtr);
```

## Arguments

### HandleType

[Input] It is the handle type identifier which requires diagnostics. The identifier should be one of the followings.

- SQL\_HANDLE\_DBC
- SQL\_HANDLE\_DESC
- SQL\_HANDLE\_ENV
- SQL\_HANDLE\_STMT

### Handle

[Input] It is the handle for the diagnostic data structure, of the type pointed by HandleType. If HandleType is SQL\_HANDLE\_ENV, the Handle can be the shared or non-shared environment handle.

**RecNumber**

[Input] It indicates the state record of the information found by the application. The status record starts from 1. If DiagIdentifier points any field of the diagnostic header, RecNumber is ignored. Otherwise, RecNumber should be bigger than 0.

**DiagIdentifier**

[Input] It refers to the diagnostic field whose value is returned. For more information, refer to **DiagIdentifier Argument** in the Description section.

**DiagInfoPtr**

[Output] It is the buffer pointer to which return the diagnostic information. The data type depends on the value of DiagIdentifier. If DiagInfoPtr is an integer type, the application should use the SQLULEN buffer and initialize it to 0 before calling the function because some drivers record only the lower 32-bits or 16-bits of the buffer and leave the upper bits intact. If DiagInfoPtr is NULL, StringLengthPtr returns the total number of returnable bytes excluding null-termination character in the buffer pointed by DiagInfoPtr.

**BufferLength**

[Input] If DiagIdentifier is the ODBC defined diagnosis, and DiagInfoPtr points to the string or binary buffer, the argument should be the length of DiagInfoPtr. If DiagIdentifier is the ODBC defined diagnosis field, and DiagInfoPtr is a number, BufferLength is ignored. If the value of DiagInfoPtr is the Unicode string (When calling SQLGetDiagFieldW), BufferLength should be an even number. If DiagIdentifier is a driver defined field, the application refers to the field characteristic to the driver manager by setting BufferLength argument. BufferLength can have the following values.

- If DiagInfoPtr is a string buffer pointer, BufferLength is the string length or SQL\_NTS.
- If DiagInfoPtr is a binary buffer pointer, the application stores the macro result of SQL\_LENG\_BINARY\_ATTR(length) in BufferLength. A negative number is stored in BufferLength.
- If DiagInfoPtr is not a string or binary buffer pointer, BufferLength should have the value of SQL\_IS\_POINTER.
- If DiagInfoPtr is the fixed length data type, BufferLength is one of SQL\_IS\_INTEGER, SQL\_IS\_INTEGER, SQL\_IS\_SMALLINT, or SQL\_IS\_USMALLINT.

**StringLengthPtr**

[Output] It is the buffer pointer which returns the total length of bytes excluding the null-termination character which is returned to \*DiagInfoPtr for the character data. If the returnable length in bytes is equal to or bigger than BufferLength, the text in \*DiagInfoPtr is truncated to the length of BufferLength minus null-termination character.

**Returns**

SQL\_SUCCESS, SQL\_SUCCESS\_WITH\_INFO, SQL\_ERROR, SQL\_INVALID\_HANDLE, SQL\_NO\_DATA



## Diagnosis

SQLGetDiagField does not post the diagnostic record. The result of the return value is used as follows.

- SQL\_SUCCESS: The function successfully returns the diagnosis information.
- SQL\_SUCCESS\_WITH\_INFO: The data in the diagnostic field is truncated because \*DiagInfoPtr is too small to store the requested diagnosis field. The application should compare BufferLength to the actual byte number stored in \*StringLengthPtr to check whether the truncation occurred.
- SQL\_INVALID\_HANDLE: The handle is not valid for a type indicating HandleType.
- SQL\_ERROR: One of the followings occurs.
  - DiagIdentifier argument does not have the valid value.
  - DiagIdentifier argument is one of SQL\_DIAG\_CURSOR\_ROW\_COUNT, SQL\_DIAG\_DYNAMIC\_FUNCTION, SQL\_DIAG\_DYNAMIC\_FUNCTION\_CODE, SQL\_DIAG\_ROW\_COUNT, and Handle is not the statement handle.
  - When DiagIdentifier refers to the diagnosis record field, RecNumber is a negative number or 0. RecNumber is ignored for the header field.
  - The requested value is a string, and BufferLength is smaller than 0.
  - If an asynchronous notification is used, the asynchronous execution of handle is not completed.
- SQL\_NO\_DATA: RecNumber is bigger than the number of diagnosis records for the handle specified in Handle. If the diagnosis record for handle does not exist, then the function returns SQL\_NO\_DATA for RecNumber of any positive number.

## Description

The application generally calls SQLGetDiagField for one of the three purposes.

- To obtain specific error or warning information when a function returns SQL\_ERROR or SQL\_SUCCESS\_WITH\_INFO (SQLBrowseConnect function returns SQL\_NEED\_DATA.)
- To obtain the number of rows in the data source when insert, delete, or update operations were performed with a call to SQLExecute, SQLExecDirect, SQLBulkOperations or SQLSetPos. Or, to obtain the number of rows which exist in the current open cursor, if the driver can provide this information.
- To obtain the information of which function is executed by a calling SQLExecDirect or SQLExecute

Whenever the function is called, all ODBC functions can post 0 or more diagnosis records. Therefore, the application can call SQLGetDiagField after calling all functions. There is no limitation on the number of diagnosis records which can be stored at a time. SQLGetDiagField retrieves the diagnosis data structure specified in Handle and the most recent related diagnosis information. If the application calls another ODBC function instead of SQLGetDiagField or SQLGetDiagRec, diagnostic information obtained by the previous call of the same handle can be lost.

As long as SQLGetDiagField returns SQL\_SUCCESS, the application can read the diagnosis record by increasing RecNumber. The number of state records is displayed on the header field of SQL\_DIAG\_NUMBER. Calling SQLGetDiagField does not affect the header and record field. As long as a function except for the d

Diagnostic function is not called, the application can retrieve a record field by calling `SQLGetDiagField` again using the same handle.

The application can call `SQLGetDiagField` anytime to return any diagnostic fields. If Handle is not the statement handle, `SQL_DIAG_CURSOR_ROW_COUNT` or `SQL_DIAG_ROW_COUNT` is excluded because it returns `SQL_ERROR`. If any diagnosis field is not defined, calling `SQLGetDiagField` returns `SQL_SUCCESS` and the undefined value.

API call other than the function executed asynchronously causes HY010 (Function sequence error). However, the error code is not retrieved before the asynchronous processing is completed.

## HandleType Argument

Each handle type has the related diagnosis information, and `HandleType` argument refers to the handle type.

Some headers and record fields are not returned for the environment, connection, statement, descriptor handles. The handles which are not applicable are described in the following Header Fields and Record Fields tables.

If `HandleType` is `SQL_HANDLE_ENV`, the handle can be the shared or non-shared environment handle.

A specific header diagnosis field of the driver is not related to the environment handle.

The diagnosis header defined for the descriptor handle is only `SQL_DIAG_NUMBER` and `SQL_DIAG_RETURNCODE`.

## DiagIdentifier Argument

The argument is the field identifier required in the diagnosis data structure. If `RecNumber` is equal to or bigger than 1, the data in the field is the diagnostic information returned by the function. If `RecNumber` is 0, the field is in the header of the diagnostic data structure, and it has the data related to the function call returning the diagnostic information, not the specific information.

The driver may define a driver-specific header and record fields in the diagnosis data structure.

ODBC 3.x application which uses ODBC 2.x driver can call `SQLGetDiagField` when `DiagIdentifier` argument is `SQL_DIAG_CLASS_ORIGIN`, `SQL_DIAG_CLASS_SUBCLASS_ORIGIN`, `SQL_DIAG_CONNECTION_NAME`, `SQL_DIAG_MESSAGE_TEXT`, `SQL_DIAG_NATIVE`, `SQL_DIAG_NUMBER`, `SQL_DIAG_RETURNCODE`, `SQL_DIAG_SERVER_NAME`, `SQL_DIAG_SQLSTATE`, and it returns `SQL_ERROR` for other diagnostic fields.

## Header Field

DiagIdentifier	Return type	Returns
		This field contains the number of rows in the cursor. Its meaning depends on the information type of <code>SQLGetInfo</code> . The information type is <code>SQL_DYNAMI</code>

DiagIdentifier	Return type	Returns
SQL_DIAG_CURSOR_ROW_COUNT	SQLLEN	C_CURSOR_ATTRIBUTES2, SQL_FORWARD_ONLY_CURSOR_ATTRIBUTES2, SQL_KEYSET_CURSOR_ATTRIBUTES2, SQL_STATIC_CURSOR_ATTRIBUTES2, and it refers to the number of rows which can be used in each cursor type. (It is in SQL_CA2_CRC_EXACT and SQL_CA2_CRC_APPROXIMATE bits.)  This field content is defined after calling the statement handle, SQLExecute, SQLExecDirect, or SQLMoreResults. SQLGetDiagField returns SQL_ERROR if DiagIdentifier is the statement handle except for SQL_DIAG_CURSOR_ROW_COUNT.
SQL_DIAG_DYNAMIC_FUNCTION	SQLCHAR *	It is a string which describes the SQL statements executing the basic function. The field content is defined after calling SQLExecute, SQLExecDirect, or SQLMoreResults. Calling SQLGetDiagField returns SQL_ERROR if DiagIdentifier is the statement handle except for SQL_DIAG_DYNAMIC_FUNCTION.
SQL_DIAG_DYNAMIC_FUNCTION_CODE	SQLINTEGER	It is the numeric code which describes the SQL statement executing the basic function. The field content is defined after calling SQLExecute, SQLExecDirect, or SQLMoreResults. Calling SQLGetDiagField returns SQL_ERROR if DiagIdentifier is the statement handle except for SQL_DIAG_DYNAMIC_FUNCTION_CODE.
SQL_DIAG_NUMBER	SQLINTEGER	It is the number of records which are in the usable state of the specified handles.
SQL_DIAG_RETURNCODE	SQLRETURN	It is the code returned by the function. The driver does not need to implement SQL_DIAG_RETURNCODE, and it is implemented by the driver manager.  If the handle is not called by any function, SQL_SUCCESS is returned for SQL_DIAG_RETURNCODE.
SQL_DIAG_ROW_COUNT	SQLLEN	It is the number of rows which are affected by the INSERT, DELETE, UPDATE statement executed by SQLExecute, SQLExecDirect, SQLBulkOperations, or SQLSetPos. It is defined by the driver after cursor specification is executed. The field content is defined only for the statement handle.  Calling SQLGetDiagField returns SQL_ERROR if DiagIdentifier is the statement handle except for SQL_DIAG_ROW_COUNT. The field data is also returned to RowCountPtr of SQLRowCount. The row count returned to SQLRowCount among data of this field remains the same until statement is set back to the prepared or allocated state, but it is set again after calling the non-diagnostic function.

## Record Field

DiagIdentifier	Return type	Returns
SQL_DIAG_CLASSES_ORIGIN	SQLCHAR *	It is a string representing the document which defines the class of SQLSTATE value in this record. This value is ISO 9075 for all SQLSTATE defined by the Open Group and the ISO call level interface. This value is ODBC 3.0 for the s

DiagIdentifier	Return type	Returns
		pecified ODBC SQLSTATE (for All SQLSTATE classes having IM).
SQL_DIAG_COLUMN_NUMBER	SQLINTEGER	<p>If SQL_DIAG_ROW_NUMBER is the valid row number in the row set or parameter set, this field is a value representing the column number of result set or parameter number of parameter sets. The result set column number always starts from 1. If the state record is related to the bookmark column, the field can be 0. The parameter number starts from 1.</p> <p>If the state record is not related to the column number or to the parameter number, the value can be SQL_NO_COLUMN_NUMBER. If the driver can not determine the column number or parameter number related to the record, the field value is SQL_COLUMN_NUMBER_UNKNOWN.</p> <p>The field content is defined only for the statement handle.</p>
SQL_DIAG_CONNECTION_NAME	SQLCHAR *	It is the string representing the connection name related to the diagnostic record. The field is the driver definition. The field is a zero-length string for the diagnosis which is not related to any server and the environment handle related to the diagnostic data structure.
SQL_DIAG_MESSAGE_TEXT	SQLCHAR *	It is an information message about the error or warning.
SQL_DIAG_NATIVE	SQLINTEGER	It is the driver/ data source-specific native error code. If native error code does not exist, the driver returns 0.
SQL_DIAG_ROW_NUMBER	SQLLEN	<p>This field contains the row number in the row set or the parameter number in the parameter set which is related to the state record. The row number and parameter number start from 1. If the state record is not related to the row number or parameter number, the field value is SQL_NO_ROW_NUMBER. If the driver can not determine the row number or parameter number related to the record, the field value is SQL_ROW_NUMBER_UNKNOWN.</p> <p>The field content is defined only for the statement handle.</p>
SQL_DIAG_SERVER_NAME	SQLCHAR *	It is the string representing the server name related to the diagnostic record. It is as same as the value returned by calling SQLGetInfo with SQL_DATA_SOURCE_NAME option. The field is a zero-length string for the diagnosis which is not related to any server and the environment handle related to the diagnostic data structure.
SQL_DIAG_SQLSTATE	SQLCHAR *	It is SQLSTATE diagnostic code of the five characters.
SQL_DIAG_SUBCLASS_ORIGIN	SQLCHAR *	<p>It is the string of the same format and valid value with SQL_DIAG_CLASS_ORIGIN which is defines the subclass part of the SQLSTATE code.</p> <p>The specific ODBC SQLSTATE codes in ODBC 3.0 are as follows. 01S00, 01S01, 01S02, 01S06, 01S07, 07S01, 08S01, 21S01, 21S02, 25S01, 25S02, 25S03, 42S01, 42S02, 42S11, 42S12, 42S21, 42S22, HY095, HY097, HY098, HY099, HY100, HY101, HY105, HY107, HY109, HY110, HY111,</p>

DiagIdentifier	Return type	Returns
		HYT00, HYT01, IM001, IM002, IM003, IM004, IM005, IM006, IM007, IM008, IM010, IM011, IM012.

## Dynamic Function Field Value

SQL statement executed	Value of SQL_DIAG_DYNAMIC_FUNCTION	Value of SQL_DIAG_DYNAMIC_FUNCTION_CODE
alter-domain-statement	"ALTER DOMAIN"	SQL_DIAG_ALTER_DOMAIN
alter-table-statement	"ALTER TABLE"	SQL_DIAG_ALTER_TABLE
assertion-definition	"CREATE ASSERTION"	SQL_DIAG_CREATE_ASSERTION
character-set-definition	"CREATE CHARACTER SET"	SQL_DIAG_CREATE_CHARACTER_SET
collation-definition	"CREATE COLLATION"	SQL_DIAG_CREATE_COLLATION
create-index-statement	"CREATE INDEX"	SQL_DIAG_CREATE_INDEX
create-table-statement	"CREATE TABLE"	SQL_DIAG_CREATE_TABLE
create-view-statement	"CREATE VIEW"	SQL_DIAG_CREATE_VIEW
cursor-specification	"SELECT CURSOR"	SQL_DIAG_SELECT_CURSOR
delete-statement-positioned	"DYNAMIC DELETE CURSOR"	SQL_DIAG_DYNAMIC_DELETE_CURSOR
delete-statement-searched	"DELETE WHERE"	SQL_DIAG_DELETE_WHERE
domain-definition	"CREATE DOMAIN"	SQL_DIAG_CREATE_DOMAIN
drop-assertion-statement	"DROP ASSERTION"	SQL_DIAG_DROP_ASSERTION
drop-character-set-stmt	"DROP CHARACTER SET"	SQL_DIAG_DROP_CHARACTER_SET
drop-collation-statement	"DROP COLLATION"	SQL_DIAG_DROP_COLLATION
drop-domain-statement	"DROP DOMAIN"	SQL_DIAG_DROP_DOMAIN
drop-index-statement	"DROP INDEX"	SQL_DIAG_DROP_INDEX
drop-schema-statement	"DROP SCHEMA"	SQL_DIAG_DROP_SCHEMA
drop-table-statement	"DROP TABLE"	SQL_DIAG_DROP_TABLE
drop-translation-statement	"DROP TRANSLATION"	SQL_DIAG_DROP_TRANSLATION
drop-view-statement	"DROP VIEW"	SQL_DIAG_DROP_VIEW
grant-statement	"GRANT"	SQL_DIAG_GRANT
insert-statement	"INSERT"	SQL_DIAG_INSERT
ODBC-procedure-extension	"CALL"	SQL_DIAG_CALL
revoke-statement	"REVOKE"	SQL_DIAG_REVOKE
schema-definition	"CREATE SCHEMA"	SQL_DIAG_CREATE_SCHEMA
translation-definition	"CREATE TRANSLATION"	SQL_DIAG_CREATE_TRANSLATION
update-statement-positioned	"DYNAMIC UPDATE CURSOR"	SQL_DIAG_DYNAMIC_UPDATE_CURSOR
update-statement-searched	"UPDATE WHERE"	SQL_DIAG_UPDATE_WHERE
Unknown	empty string	SQL_DIAG_UNKNOWN_STATEMENT

## Sequence of Status Record

The state record is sequentially located according to the row number and diagnostic type. The driver manager determines the final step of returning the created state record.

If the diagnostic record is posted by the driver manager and the driver, the driver manager is responsible for determining the order of the diagnostic records.

If two or more state records exist, the order of the record is determined first by the row number. The following rules are applied to determine the order of the diagnostic record by the row.

- The record not corresponding to any row because SQL\_NO\_ROW\_NUMBER is defined as -1, is positioned in front of the record corresponding to the particular row.
- The record which does not know the row number because SQL\_ROW\_NUMBER\_UNKNOWN is defined as -2 is positioned in front of all the other records.
- For all record which are related to a particular row, the records are sorted by the value of SQL\_DIAG\_ROW\_NUMBER. All errors and warnings for the first row are listed, and then all the errors and warnings for the next row are sequentially listed.



If SQLSTATE 01S01 is returned by the ODBC 2.x driver, or SQLSTATE 01S01 is returned by the ODBC 3.x driver when calling SQLExtendedFetch or when calling SQLSetPos for the cursor in SQLExtendedFetch, then the ODBC 3.x driver manager does not require the state record in a diagnosis queue.

Within each row, or for all rows which do not correspond to the row or which do not know the row number or which have the row number as same as SQL\_NO\_ROW\_NUMBER, the first record listed is determined by using the set of ordering rules. After the first record, the order of other records which affect the row is not defined. The application can not assume that an error precedes a warning after the first record. The application should check the complete diagnostic data structure to get the complete information about the failed function call.

The following rules are used to determine the first record in the row. The highest grade record is the first record. The record source (driver manager, driver, gateway, etc.) does not affect the determination of the record ranks.

- Errors state record describing the error has the highest grade. The following rules are applied to align the errors.
  - The record which refers to the transaction failure or possible transaction failure has a higher grade than any other record.
  - If two or more records describe the same error condition, SQLSTATE defined in the Open Group CLI specifications(Class 03 ~ HZ) has a higher grade than SQLSTATE defined in ODBC and the driver.

- Implementation-defined No Data Values state record which describes No Data values (class 02) defined by the driver has the second highest rank.
- Warnings state record(class 01) describing the warning has the lowest grade. If two or more records describe the same error condition, SQLSTATE defined in the Open Group CLI specifications has a higher grade than SQLSTATE defined in ODBC and the driver.

# SQLGetDiagRec

## Conformance

Introduced version: ODBC 3.0

Standards compliance: ISO 92

## Overview

SQLGetDiagRec returns the current value of the record field of the diagnostic data source (related to the specified handle) which contains an error, warning, state information.

## Syntax

```
SQLRETURN SQLGetDiagRec(  
    SQLSMALLINT    HandleType,  
    SQLHANDLE      Handle,  
    SQLSMALLINT    RecNumber,  
    SQLCHAR *      SQLState,  
    SQLINTEGER *   NativeErrorPtr,  
    SQLCHAR *      MessageText,  
    SQLSMALLINT    BufferLength,  
    SQLSMALLINT *  TextLengthPtr);
```

## Arguments

### HandleType

[Input] It is the handle type identifier of which diagnosis is required. The identifier should be one of the followings.

- SQL\_HANDLE\_DBC
- SQL\_HANDLE\_DESC
- SQL\_HANDLE\_ENV
- SQL\_HANDLE\_STMT

### Handle

[Input] It is the handle for the diagnosis data structure of the type pointed by HandleType. If HandleType is SQL\_HANDLE\_ENV, the handle can be the shared or non-shared environment handle.



**RecNumber**

[Input] It indicates the state record of the information found by the application. The number of the state record starts from 1.

**SQLState**

[Output] It is the buffer pointer which returns five character SQLSTATE code for the diagnostic record RecNumber. The first two characters indicate a class and the next three characters indicate a subclass. The information is in the SQL\_DIAG\_SQLSTATE diagnostic field.

**NativeErrorPtr**

[Output] It is the buffer pointer which returns the specific native error code to the data source. The information is in the diagnostic field SQL\_DIAG\_NATIVE.

**MessageText**

[Output] It is the buffer point which returns the diagnostic message text string. The information is in the SQL\_DIAG\_MESSAGE\_TEXT diagnostic field.

If MessageText is NULL, TextLegnthPtr returns the total number of returnable characters (excluding null-termination character) to the buffer pointed by MessageText.

**BufferLength**

[Input] It is the length of characters within \*MessageText buffer. Diagnostic message text does not have the maximum length.

**TextLegnthPtr**

[Output] It is the buffer pointer to which the total number of characters returnable to \*MessageText is returned (excluding null-termination character). If the number of returnable characters is bigger than BufferLength, the diagnostic message text of \*MessageText is truncated to the length of BufferLength minus null-termination character.

**Returns**

SQL\_SUCCESS, SQL\_SUCCESS\_WITH\_INFO, SQL\_ERROR, SQL\_INVALID\_HANDLE

**Diagnosis**

SQLGetDiagRec does not post the diagnostic record. It uses the result of the return value as follows.

- SQL\_SUCCESS: The function successfully returns the diagnosis information.
- SQL\_SUCCESS\_WITH\_INFO: \*MessageText buffer is too small to store the requested diagnosis message. The diagnostic record is not generated. The application should compare BufferLength to the actual byte number stored in \*StringLengthPtr to check whether the truncation occurred.
- SQL\_INVALID\_HANDLE: The handle is not valid for a type indicating HandleType.
- SQL\_ERROR: One of the followings occurs.
  - RecNumber argument is the negative number or 0.

- BufferLength is smaller than 0.
- If an asynchronous notification is used, the asynchronous execution of handle is not completed.
- SQL\_NO\_DATA: RecNumber is bigger than the number of diagnosis records for the handle specified in Handle. If the diagnosis record for handle does not exist, then the function returns SQL\_NO\_DATA for RecNumber of any positive number.

## Description

When the ODBC function returns SQL\_ERROR or SQL\_SUCCESS\_WITH\_INFO, generally the application calls SQLGetDiagRec. However, the application can call the SQLGetDiagRec after any function is called because any ODBC function can post zero or more diagnostic records. The application can call SQLGetDiagRec several times to return some or all records in the diagnostic data structure. ODBC does not have limit on the number of diagnostic records which can be stored at a time.

SQLGetDiagRec can not be used to return the header field of the diagnostic data structure. (RecNumber should be bigger than 0.) The application should call SQLGetDiagField instead of SQLGetDiagRec.

SQLGetDiagRec retrieves only the handle specified to Handle and the latest related diagnostic information. If the application calls any other ODBC function (excluding SQLGetDiagRec, SQLGetDiagField, SQLERROR), diagnostic information from the previous call of the same handle is lost.

The application can repeatedly retrieve the diagnostic record by increasing RecNumber as long as SQLGetDiagRec returns SQL\_SUCCESS. SQLGetDiagRec call do not affect the header and record fields. If intervention of other function does not exist except for SQLGetDiagRec, SQLGetDiagField, SQLERROR, then the application can call SQLGetDiagRec again to retrieve the field in the record. The application can retrieve the total number of diagnostic records available by calling SQLGetDiagField to retrieve the value of the SQL\_DIAG\_NUMBER field, and calling SQLGetDiagRec several times.

## HandleType Argument

Each handle type has the related diagnosis information, and HandleType argument refers to the Handle type.

Some header and record fields are not returned for the environment, connection, statement, descriptor handles. In the header field and record field table of **SQLGetDiagField**, the inappropriate handles in the field are described.

If HandleType is SQL\_HANDLE\_SENV which indicates the shared environment handle, then calling SQLGetDiagRec returns SQL\_INVALID\_HANDLE. If HandleType is SQL\_HANDLE\_ENV, then the handle can be the shared or non-shared environment handle.

# SQLGetEnvAttr

## Conformance

Introduced version: ODBC 3.0

Standards compliance: ISO 92

## Overview

SQLGetEnvAttr returns the current settings of the environment attributes.

## Syntax

```
SQLRETURN SQLGetEnvAttr(  
    SQLHENV      EnvironmentHandle,  
    SQLINTEGER   Attribute,  
    SQLPOINTER  ValuePtr,  
    SQLINTEGER   BufferLength,  
    SQLINTEGER * StringLengthPtr);
```

## Arguments

### EnvironmentHandle

[Input] It is the environment handle.

### Attribute

[Input] It is the attribute to be retrieved.

### ValuePtr

[Output] It is the buffer pointer in which to return the current attribute value specified by Attribute. If ValuePtr is NULL, StringLengthPtr returns the total number of bytes returnable to the buffer pointed by ValuePtr (excluding null-termination character).

### BufferLength

[Input] If ValuePtr points to a string, the argument should be the length of \*ValuePtr. If ValuePtr is an integer, BufferLength is ignored. If \*ValuePtr (when SQLGetEnvAttrW is called) is a unicode string, BufferLength should be an even number. If the attribute value is not a string, BufferLength is not used.

## StringLengthPtr

[Output] It is the buffer pointer to which the total number of bytes to be returned to \*ValuePtr (excluding null-termination character) is returned. If ValuePtr is the null pointer, the length is not returned. If the attribute value is a string and the number of bytes returnable is equal to or bigger than BufferLength, \*ValuePtr is truncated to the length of BufferLength minus the length of a null-termination character and is a null-terminated by the driver.

## Returns

SQL\_SUCCESS, SQL\_SUCCESS\_WITH\_INFO, SQL\_NO\_DATA, SQL\_ERROR, SQL\_INVALID\_HANDLE

## Diagnosis

SQLSTATE	Error	Description
01000	General Warning	It is the driver-specific informational message. (The function returns SQL_SUCCESS_WITH_INFO.)
01004	String data, right truncated	The data returned to *ValuePtr is truncated to the length of BufferLength minus null-termination character. The remaining length of string is returned to *StringLengthPtr. (The function returns SQL_SUCCESS_WITH_INFO.)
HY000	General error	It is an error without any specific SQLSTATE.
HY001	Memory allocation error	It is a memory allocation error.
HY010	Function sequence error	SQL_ATTR_ODBC_VERSION is not set through SQLSetEnvAttr. If SQLAllocHandleStd is used, then SQL_ATTR_ODBC_VERSION does not need to be explicitly set.
HY013	Memory management error	The size of buffer used as an argument is smaller than 0 or it can not access the memory.
HY092	Invalid attribute/option identifier	The value specified in attribute argument is not valid for ODBC version supported by the driver.
HY117	Connection is suspended due to unknown transaction state. Only disconnect and read-only functions are allowed.	For more information about the suspended state, refer to <b>SQLEndTran</b> .
HYC00	Optional feature not implemented	The value specified in attribute argument is valid for ODBC environment of ODBC version supported by the driver, but it is not supported by the driver.
IM001	Driver does not support this function	The driver related to DescriptorHandle does not support the function.

## Description

The driver-specific environment attributes does not exist. If Attribute specifies the attribute which returns a string, ValuePtr should be the buffer pointer whose string is returned. The maximum string length including the null-termination character is the BufferLength in bytes.

SQLGetEnvAttr can be called at any point between the allocation and release of the environment handle. All environment attributes successfully allocated by the application for the environment are maintained until SQLFreeHandle is called with Handletype of SQL\_HANDLE\_ENV in EnvironmentHandle. It is recommended to use only one environment handle.



SQL\_ATTR\_OUTPUT\_NTS environment attributes are supported by the application which complies with standards. If SQLGetEnvAttr is called, ODBC 3.x driver manager always returns SQL\_TRUE for the attribute. SQL\_ATTR\_OUTPUT\_NTS is set to SQL\_TRUE only by calling SQLSetEnvAttr.

The following table describes attribute list which can be queried through SQLGetEnvAttr.

Attribute	ValuePtr Content
SQL_ATTR_CONNECTION_POOLING (ODBC 3.8)	It is not supported by the driver.
SQL_ATTR_CP_MATCH (ODBC 3.0)	It is not supported by the driver.
SQL_ATTR_ODBC_VERSION (ODBC 3.0)	<p>It is 32-bit integer which indicates whether a particular feature is operated as ODBC 2.x or ODBC 3.x. The following values are used to set the attribute.</p> <p>SQL_OV_ODBC3_80 = The driver manager or driver performs the following ODBC 3.8 behaviors.</p> <ul style="list-style-type: none"> <li>The driver expects and returns ODBC 3.x code values for DATE, TIME, TIMESTAMP.</li> <li>The driver returns ODBC 3.x SQLSTATE codes when SQLError, SQLGetDiagField or SQLGetDiagRec is called.</li> <li>CatalogName argument of SQLTables allows the pattern matching.</li> </ul> <p>SQL_OV_ODBC3 = The driver manager or driver performs the following ODBC 3.x behaviors.</p> <ul style="list-style-type: none"> <li>The driver expects and returns ODBC 3.x code values for DATE, TIME, TIMESTAMP.</li> <li>The driver returns ODBC 3.x SQLSTATE codes when SQLError, SQLGetDiagField or SQLGetDiagRec is called.</li> <li>CatalogName argument of SQLTables allows the pattern matching.</li> <li>The driver manager does not support C data type extensibility.</li> </ul>

Attribute	ValuePtr Content
	<p>SQL_OV_ODBC2 = The driver manager or driver performs the following ODBC 2.x behaviors. It is very helpful when ODBC 2.x applications operate in the ODBC 3.x driver.</p> <ul style="list-style-type: none"> <li>• The driver expects and returns ODBC 2.x code values for DATE, TIME, TIMESTAMP.</li> <li>• The driver returns ODBC 2.x SQLSTATE codes when SQLError, SQLGetDiagField or SQLGetDiagRec is called.</li> <li>• CatalogName argument of SQLTables does not allow the pattern matching.</li> <li>• The driver manager does not support C data type extensibility.</li> </ul> <p>An application should set this environment attribute before it calls any function which has an SQLHENV argument or a function which returns SQLSTATE HY010 (Function sequence error). The driver should specify whether the additional operations for the environmental flag exists.</p>
SQL_ATTR_OUTPUT_NTS (ODBC 3.0)	It is not supported by the driver.

# SQLGetFunctions

## Conformance

Introduced version: ODBC 1.0

Standards compliance: ISO 92

## Overview

SQLGetFunctions returns information whether the driver supports the given ODBC function. The function is implemented by the driver manager or the driver. If the driver implements SQLGetFunctions, the driver manager will call the function in the driver.

## Syntax

```
SQLRETURN SQLGetFunctions(
    SQLHDBC          ConnectionHandle,
    SQLUSMALLINT     FunctionId,
    SQLUSMALLINT *   SupportedPtr);
```

## Arguments

### ConnectionHandle

[Input] It is the connection handle.

### FunctionId

[Input] It is the #define value which identifies the ODBC function related to SQL\_API\_ODBC3\_ALL\_FUNCTIONS or SQL\_API\_ALL\_FUNCTIONS. SQL\_API\_ODBC3\_ALL\_FUNCTIONS is used in ODBC 3.x application to determine to support the function in ODBC 3.x and in earlier version. SQL\_API\_ALL\_FUNCTIONS is used in ODBC 2.x to determine whether to support the function in ODBC 2.x and in earlier version.

For more information about the value list of #define which identifies the ODBC function, refer to the table in the description section.

### SupportedPtr

[Output] If FunctionId identifies the single ODBC, SupportedPtr points to the single SQLUSMALLINT value. If the specified function is supported by the driver, it is SQL\_TRUE. Otherwise, it is SQL\_FALSE.

If FunctionId is SQL\_API\_ODBC3\_ALL\_FUNCTIONS, SupportedPtr points to the SQLSMALLINT array

which has the number of elements equal to `SQL_API_ODBC3_ALL_FUNCTIONS_SIZE`. The array is managed by the driver manager as 4000-bit bitmap which can be used to determine to support the function in ODBC 3.x or in earlier version. `SQL_FUNC_EXISTS` macro is called to check whether the function is supported. ODBC 3.x application can call `SQLGetFunctions` by using `SQL_API_ODBC3_ALL_FUNCTIONS` in preparation for ODBC 2.x or ODBC 3.x.

If `FunctionId` is `SQL_API_ALL_FUNCTIONS`, `SupportedPtr` points to the array with 100 elements. The array is indexed by `#define` value used by the `FunctionId` to identify each ODBC function, and several elements are reserved without being used. If the function in ODBC 2.x or earlier version is supported by the driver, the element is `SQL_TRUE`. If the ODBC function is not supported by the driver or it is not the ODBC function, the element is `SQL_FALSE`.

The array that is returned to `*SupportedPtr` uses the 0-based indexing.

## Returns

`SQL_SUCCESS`, `SQL_SUCCESS_WITH_INFO`, `SQL_ERROR`, `SQL_INVALID_HANDLE`

## Diagnosis

SQLSTATE	Error	Description
01000	General Warning	It is the driver-specific informational message. (The function returns <code>SQL_SUCCESS_WITH_INFO</code> .)
08S01	Communication link failure	Before the function processing is completed, the connection between the driver and the data source is failed.
HY000	General error	It is an error without any specific SQLSTATE.
HY001	Memory allocation error	It is a memory allocation error.
HY010	Function sequence error	<p><code>SQLGetFunctions</code> is called before <code>SQLConnect</code>, <code>SQLBrowseConnect</code>, <code>SQLDriverConnect</code>.</p> <p><code>SQLBrowseConnect</code> is called for <code>ConnectionHandle</code>, and <code>SQL_NEED_DATA</code> is returned.</p> <p><code>SQLGetfunction</code> is called before <code>SQLBrowseConnect</code> returns <code>SQL_SUCCESS_WITH_INFO</code> or <code>SQL_SUCCESS</code>.</p> <p><code>SQLExecute</code>, <code>SQLExecDirect</code>, <code>SQLMoreResults</code> is called for <code>ConnectionHandle</code>, and <code>SQL_PARAM_DATA_AVAILABLE</code> is returned. The function is called, before the data retrieves all streamed parameters.</p>
HY013	Memory management error	The size of buffer used as an argument is smaller than 0, or it can not access the memory.
HY095	Function type out of range	<code>FunctionId</code> value is not valid.



SQLSTATE	Error	Description
HY117	Connection is suspended due to unknown transaction state. Only disconnect and read-only functions are allowed.	For more information about the suspended state, refer to <b>SQLEndTran</b> .
HYT01	Connection timeout expired	The connection is expired before the data source response to the request. The connection timeout interval can be set to <b>SQL_ATTR_CONNECTION_TIMEOUT</b> through <b>SQLSetConnectAttr</b> .
IM001	Driver does not support this function	The driver related to DescriptorHandle does not support the function.

## Description

**SQLGetFunctions** returns the supported **SQLGetFunctions**, **SQLDataSources**, **SQLDrivers**. This is because the function is implemented in the driver manager. If an unicode function exist, the driver manager maps the ANSI function corresponding to the Unicode function. If an ANSI function exist, the driver manager maps the unicode function corresponding to the ANSI function.

The following is the list of valid values for **FunctionId** for the functions which comply with ISO 92 standards compliance level.

- **SQL\_API\_SQLALLOCHANDLE**
- **SQL\_API\_SQLBINDCOL**
- **SQL\_API\_SQLCANCEL**
- **SQL\_API\_SQLCLOSECURSOR**
- **SQL\_API\_SQLCOLATTRIBUTE**
- **SQL\_API\_SQLCONNECT**
- **SQL\_API\_SQLCOPYDESC**
- **SQL\_API\_SQLDATASOURCES**
- **SQL\_API\_SQLDESCRIBECOL**
- **SQL\_API\_SQLDISCONNECT**
- **SQL\_API\_SQLDRIVERS**
- **SQL\_API\_SQLENDTRAN**
- **SQL\_API\_SQLEXECDIRECT**
- **SQL\_API\_SQLEXECUTE**
- **SQL\_API\_SQLFETCH**
- **SQL\_API\_SQLFETCHSCROLL**
- **SQL\_API\_SQLFREEHANDLE**
- **SQL\_API\_SQLFREESTMT**

- SQL\_API\_SQLGETCONNECTATTR
- SQL\_API\_SQLGETCURSORNAME
- SQL\_API\_SQLGETDATA
- SQL\_API\_SQLGETDESCFIELD
- SQL\_API\_SQLGETDESCREC
- SQL\_API\_SQLGETDIAGFIELD
- SQL\_API\_SQLGETDIAGREC
- SQL\_API\_SQLGETENVATTR
- SQL\_API\_SQLGETFUNCTIONS
- SQL\_API\_SQLGETINFO
- SQL\_API\_SQLGETSTMTATTR
- SQL\_API\_SQLGETTYPEINFO
- SQL\_API\_SQLNUMRESULTCOLS
- SQL\_API\_SQLPARAMDATA
- SQL\_API\_SQLPREPARE
- SQL\_API\_SQLPUTDATA
- SQL\_API\_SQLROWCOUNT
- SQL\_API\_SQLSETCONNECTATTR
- SQL\_API\_SQLSETCURSORNAME
- SQL\_API\_SQLSETDESCFIELD
- SQL\_API\_SQLSETDESCREC
- SQL\_API\_SQLSETENVATTR
- SQL\_API\_SQLSETSTMTATTR

The following is the list of valid values for FunctionId for the functions which comply with open group standard compliance level.

- SQL\_API\_SQLCOLUMNS
- SQL\_API\_SQLSPECIALCOLUMNS
- SQL\_API\_SQLSTATISTICS
- SQL\_API\_SQLTABLES

The following is the list of valid values for FunctionId for the functions which comply with ODBC standard compliance level.

- SQL\_API\_SQLBINDPARAMETER
- SQL\_API\_SQLBROWSECONNECT
- SQL\_API\_SQLBULKOPERATIONS<sup>[1]</sup>
- SQL\_API\_SQLCOLUMNPRIVILEGES
- SQL\_API\_SQLDESCRIBEPARAM
- SQL\_API\_SQLDRIVERCONNECT
- SQL\_API\_SQLFOREIGNKEYS

- SQL\_API\_SQLMORERESULTS
- SQL\_API\_SQLNATIVESQL
- SQL\_API\_SQLNUMPARAMS
- SQL\_API\_SQLPRIMARYKEYS
- SQL\_API\_SQLPROCEDURECOLUMNS
- SQL\_API\_SQLPROCEDURES
- SQL\_API\_SQLSETPOS
- SQL\_API\_SQLTABLEPRIVILEGES

[1] When operating with ODBC 2.x driver, SQLBulkOperations is supported and returned only when the both of the followings are true. ODBC 2.x driver supports SQLSetPos, and the SQL\_POS\_OPERATIONS information type returns SQL\_POS\_ADD bit as set.

The valid value of FunctionId for the functions introduced after ODBC 3.8 is SQL\_API\_SQLCANCELHANDLE. [2]

[2] SQLCancelHandle is returned only when the driver supports both of SQLCancel and SQLCancelHandle. If SQLCancel is supported but SQLCancelHandle is not supported, the application can still call SQLCancelHandle for the statement handle, because it is mapped to SQLCancel.

## SQL\_FUNC\_EXISTS Macro

SQL\_FUNC\_EXISTS (SupportedPtr, FunctionID) macro is used to call SQLGetFunctions to SQL\_API\_ODBC3\_ALL\_FUNCTIONS by using FunctionId argument and to check the function supported in ODBC 3.x or in the earlier version. The application uses SQL\_FUNC\_EXISTS by setting SupportedPtr transferred from SQLGetFunctions to SupportedPtr argument and by setting the FunctionID argument to the #define for the function. If the function is supported, SQL\_FUNC\_EXISTS returns SQL\_TRUE. Otherwise, it returns SQL\_FALSE.



When operating with ODBC 2.x driver, ODBC 3.x driver manager returns SQL\_TRUE for SQLAllocHandle and SQLFreeHandle. It is because SQLAllocHandle is mapped to SQLAllocEnv, SQLAllocConnect or SQLAllocStmt, and SQLFreeHandle is mapped to SQLFreeEnv, SQLFreeConnect or SQLFreeStmt. However, although SQLFreeHandle returns SQL\_TRUE, SQLFreeHandle whose SQL\_HANDLE\_DESC is used as HandleType argument is not supported. It is because function mapped to ODBC 2.x function for this case does not exist.

# SQLGetGroupCount

## Conformance

Standards compliance: It is not available.

## Overview

SQLGetGroupCount returns the number of cluster groups.

## Syntax

```
SQLRETURN SQLGetGroupCount(  
    SQLHDBC      ConnectionHandle,  
    SQLINTEGER * GroupCountPtr );
```

## Arguments

### ConnectionHandle

[Input] It is the connection handle.

### GroupCountPtr

[Output] It is the number of cluster groups.

## Returns

SQL\_SUCCESS, SQL\_NO\_DATA, SQL\_ERROR, SQL\_INVALID\_HANDLE

## Diagnosis

SQLSTATE	Error	Description
08003	Connection not open	ConnectionHandle is not in a connected state.
08S01	Communication link failure	Before the function processing is completed, the connection between the driver and the data source is failed.
HY010	Function sequence error	This function should be called only when the connection property SQL_ATTR_LOCALITY_AWARE_TRANSACTION is set.

## Description

SQLGetGroupCount can be called only when the connection property SQL\_ATTR\_LOCALITY\_AWARE\_TRANSACTION is set.

# SQLGetGroupIDs

## Conformance

Standards compliance: It is not available.

## Overview

SQLGetGroupIDs returns IDs of cluster groups.

## Syntax

```
SQLRETURN SQLGetGroupIDs(  
    SQLHDBC      ConnectionHandle,  
    SQLINTEGER * GroupIDArray );
```

## Arguments

### ConnectionHandle

[Input] It is the connection handle.

### GroupIDArray

[output] It is the array of cluster group IDs.

## Returns

SQL\_SUCCESS, SQL\_NO\_DATA, SQL\_ERROR, SQL\_INVALID\_HANDLE

## Diagnosis

SQLSTATE	Error	Description
08003	Connection not open	ConnectionHandle is not in a connected state.
08S01	Communication link failure	Before the function processing is completed, the connection between the driver and the data source is failed.
HY010	Function sequence error	This function should be called only when the connection property SQL_ATTR_LOCALITY_AWARE_TRANSACTION is set.

## Description

SQLGetGroupID can be called only when the connection property SQL\_ATTR\_LOCALITY\_AWARE\_TRANSACTION is set.

The number of elements of GroupIDArray should be as same as the number of cluster groups which are returned by SQLGetGroupCount.

# SQLGetGroupName

## Conformance

Standards compliance: It is not available.

## Overview

SQLGetGroupName returns the name of the cluster group which corresponds to GroupID.

## Syntax

```
SQLRETURN SQLGetGroupName(  
    SQLHDBC      ConnectionHandle,  
    SQLINTEGER   GroupID,  
    SQLCHAR      * GroupName,  
    SQLSMALLINT  BufferLength,  
    SQLSMALLINT * NameLengthPtr );
```

## Arguments

### ConnectionHandle

[Input] It is the connection handle.

### GroupID

[Input] It is the cluster group ID.

### GroupName

[output] It is the buffer pointer which returns the name of the cluster group which is terminated with null.

### BufferLength

[Input] It is the length of \*GroupName.

### NameLengthPtr

[Output] It is the buffer pointer which returns the total number of bytes returnable to \*ColumnName (excluding the null-termination character). If the returnable length is equal to or bigger than BufferLength, \*ColumnName is truncated to the length of BufferLength minus null.



## Returns

SQL\_SUCCESS, SQL\_SUCCESS\_WITH\_INFO, SQL\_NO\_DATA, SQL\_ERROR, SQL\_INVALID\_HANDLE

## Diagnosis

SQLSTATE	Error	Description
01004	String data, right truncated	The size of *GroupName is not large enough to return the name of the cluster group, so the name of the cluster group is truncated. The length of the cluster name which is not truncated is returned in *NameLengthPtr. (The function returns SQL_SUCCESS_WITH_INFO.)
08003	Connection not open	ConnectionHandle is not in a connected state.
08S01	Communication link failure	Before the function processing is completed, the connection between the driver and the data source is failed.
HY010	Function sequence error	This function should be called only when the connection property SQL_ATTR_LOCALITY_AWARE_TRANSACTION is set.

## Description

SQLGetGroupIDs can be called only when the connection property SQL\_ATTR\_LOCALITY\_AWARE\_TRANSACTION is set.

# SQLGetInfo

## Conformance

Introduced version: ODBC 1.0

Standards compliance: ISO 92

## Overview

SQLGetInfo returns the general information on the connection associated with the driver and the data source.

## Syntax

```
SQLRETURN SQLGetInfo(  
    SQLHDBC          ConnectionHandle,  
    SQLUSMALLINT     InfoType,  
    SQLPOINTER       InfoValuePtr,  
    SQLSMALLINT      BufferLength,  
    SQLSMALLINT *    StringLengthPtr);
```

## Arguments

### ConnectionHandle

[Input] It is the connection handle.

### InfoType

[Input] It is the information type.

### InfoValuePtr

[Output] It is the buffer pointer whose information is returned. According to InfoType requested, one of the following information will be returned. Null termination character, SQLUSMALLINT value, SQLINTEGER bit mask, SQLINTEGER flag, SQLINTEGER binary value, or SQLULEN value.

If InfoType argument is SQL\_DRIVER\_HDESC or SQL\_DRIVER\_HSTMT, InfoValuePtr argument is input and output.

If InfoValuePtr is NULL, StringLengthPtr returns the total number of returnable bytes to the buffer pointed by InfoValuePtr (null termination character is excluded).

## BufferLength

[Input] It is the length of \*InfoValuePtr buffer. If \*InfoValuePtr is not a string or InfoValuePtr is the null pointer, BufferLength argument is ignored. The driver assumes the size of \*InfoValuePtr as SQLUSMALLINT or SQLINTEGER according to InfoType. (When SQLGetInfoW is called) if InfoValuePtr is a unicode string, BufferLength must be an even number. Otherwise SQLSTATE HY090 is returned.

## StringLengthPtr

[Output] It is the buffer pointer which returns the total number of bytes returnable to \*InfoValuePtr (excluding null-termination character for the character data).

If the number of bytes returnable for the character is equal to or bigger than BufferLength, the information in \*InfoValuePtr is truncated to the length of BufferLength in byte (excluding null-termination character) and is null terminated by the driver.

BufferLength is ignored for the data of the other data types, and the driver assumes the size of \*InfoValuePtr as SQLUSMALLINT or SQLINTEGER according to InfoType.

## Returns

SQL\_SUCCESS, SQL\_SUCCESS\_WITH\_INFO, SQL\_ERROR, or SQL\_INVALID\_HANDLE

## Diagnosis

SQLSTATE	Error	Description
01000	General Warning	It is the driver-specific informational message. (The function returns SQL_SUCCESS_WITH_INFO.)
01004	String data, right truncated	The buffer length of *InfoValuePtr is not large enough to return all required information, so the information is truncated. The length of untruncated information is returned to *StringLengthPtr. (The function returns SQL_SUCCESS_WITH_INFO.)
08003	Connection not open	The connection should be open for the type of information requested in InfoType. SQL_ODBC_VER which is the reserved information in ODBC can be returned without open connection.
08S01	Communication link failure	Before the function processing is completed, the connection between the driver and the data source is failed.
HY000	General error	It is an error without any specific SQLSTATE.
HY001	Memory allocation error	It is a memory allocation error.
HY010	Function sequence error	SQLExecute, SQLExecDirect, or SQLMoreResults is called for StatementHandle, and SQL_PARAM_DATA_AVAILABLE is returned. The function is called, before the data retrieves all streamed parameters.
HY013	Memory management error	The size of buffer used as an argument is smaller than 0, or it can not access the memory.

SQLSTATE	Error	Description
HY024	Invalid attribute value	The InfoType argument is SQL_DRIVER_HSTMT, and the value pointed by InfoValuePtr is an invalid statement handle.  The InfoType argument is SQL_DRIVER_HDESC, the value pointed by InfoValuePtr is an invalid descriptor handle.
HY090	Invalid string or buffer length	The value for BufferLength argument is smaller than 0.  The value for BufferLength argument is an odd number, and *InfoValuePtr is the unicode data type.
HY096	Information type out of range	The value specified in InfoType argument is not valid for ODBC version which is supported by the driver.
HY117	Connection is suspended due to unknown transaction state. Only disconnect and read-only functions are allowed.	For more information about the suspended state, refer to <b>SQLEndTran</b> .
HYC00	Optional field not implemented	The value specified in InfoType is the specific driver value which is not supported by the driver.
HYT01	Connection timeout expired	The connection is expired before the data source responds to the request. The timeout can be set via SQL_ATTR_CONNECTION_TIMEOUT of SQLSetStmtAttr.
IM001	Driver does not support this function	The driver which is related to DescriptorHandle does not support the function.

## Description

The currently defined information types will be described in the following sections. The range of information types is reserved by ODBC. The driver developer should reserve the values for the driver-specific use of their own from Open Group. SQLGetInfo does not perform unicode conversion or thunking for InfoTypes defined by the driver. The information type returned to \*InfoValuePtr is determined according to InfoTypes requested.

SQLGetInfo returns one of the following five types.

- Null-termination string
- SQLUSMALLINT value
- SQLUINTEGER bit mask
- SQLUINTEGER value
- SQLUINTEGER binary value

The application should cast according to the value returned in \*InfoValuePtr.

The driver should return a value for each information type defined in the following table. If the information type is not applied to the driver or the data source, the driver has to return one of the following values.

**Character string ("Y" or "N")**

"N"

**Character string (not "Y" or "N")**

Empty string

**SQLUSMALLINT**

0

**SQLUIINTEGER bit mask or SQLUIINTEGER binary value**

0L

For example, if the data source does not support the procedure, SQLGetInfo returns the following value for the value of InfoType related to the procedure.

**SQL\_PROCEDURES**

"N"

**SQL\_ACCESSIBLE\_PROCEDURES**

"N"

**SQL\_MAX\_PROCEDURE\_NAME\_LEN**

0

**SQL\_PROCEDURE\_TERM**

Empty string

SQLGetInfo returns SQLSTATE HY096 for the value of InfoType which is in the range of information type reserved for use by ODBC but which is not defined by the ODBC version supported by the driver. The driver compiles and calls SQLGetInfo as the SQL\_DRIVER\_ODBC\_VER information type of an application to determine the ODBC version. SQLGetInfo returns SQLSTATE HYC00 for the value of InfoType which is in the range of reserved information type for the separate use of the driver but which is not supported by the driver.

Calling all SQLGetInfo should be open for connection, except for InfoType which returns the driver manager version is SQL\_ODBC\_VER.

## Driver Information

The following values of InfoType argument return ODBC information such as an active statement, data source name, interface standards compliance level.

- SQL\_ACTIVE\_ENVIRONMENTS
- SQL\_ASYNC\_DBC\_FUNCTIONS
- SQL\_ASYNC\_MODE
- SQL\_ASYNC\_NOTIFICATION
- SQL\_BATCH\_ROW\_COUNT
- SQL\_BATCH\_SUPPORT
- SQL\_DATA\_SOURCE\_NAME
- SQL\_DRIVER\_AWARE\_POOLING\_SUPPORTED
- SQL\_DRIVER\_HDBC
- SQL\_DRIVER\_HDESC
- SQL\_DRIVER\_HENV
- SQL\_DRIVER\_HLIB
- SQL\_DRIVER\_HSTMT
- SQL\_DRIVER\_NAME
- SQL\_DRIVER\_ODBC\_VER
- SQL\_DRIVER\_VER
- SQL\_DYNAMIC\_CURSOR\_ATTRIBUTES1
- SQL\_DYNAMIC\_CURSOR\_ATTRIBUTES2
- SQL\_FORWARD\_ONLY\_CURSOR\_ATTRIBUTES1
- SQL\_FORWARD\_ONLY\_CURSOR\_ATTRIBUTES2
- SQL\_FILE\_USAGE
- SQL\_GETDATA\_EXTENSIONS
- SQL\_INFO\_SCHEMA\_VIEWS
- SQL\_KEYSET\_CURSOR\_ATTRIBUTES1
- SQL\_KEYSET\_CURSOR\_ATTRIBUTES2
- SQL\_MAX\_ASYNC\_CONCURRENT\_STATEMENTS
- SQL\_MAX\_CONCURRENT\_ACTIVITIES
- SQL\_MAX\_DRIVER\_CONNECTIONS
- SQL\_ODBC\_INTERFACE\_CONFORMANCE
- SQL\_ODBC\_STANDARD\_CLI\_CONFORMANCE
- SQL\_ODBC\_VER
- SQL\_PARAM\_ARRAY\_ROW\_COUNTS
- SQL\_PARAM\_ARRAY\_SELECTS
- SQL\_ROW\_UPDATES
- SQL\_SEARCH\_PATTERN\_ESCAPE
- SQL\_SERVER\_NAME
- SQL\_STATIC\_CURSOR\_ATTRIBUTES1
- SQL\_STATIC\_CURSOR\_ATTRIBUTES2



When performing SQLGetInfo, the driver can improve the performance by minimizing the number of requests or of the number of transmitting information from the server.

## DBMS Product Information

The following values of InfoType argument return information on the DBMS product such as DBMS name and information.

- SQL\_DATABASE\_NAME
- SQL\_DBMS\_NAME
- SQL\_DBMS\_VER

## Data Source Information

The following values of InfoType argument return information on the data source such as cursor characteristics and transaction features.

- SQL\_ACCESSIBLE\_PROCEDURES
- SQL\_ACCESSIBLE\_TABLES
- SQL\_BOOKMARK\_PERSISTENCE
- SQL\_CATALOG\_TERM
- SQL\_COLLATION\_SEQ
- SQL\_CONCAT\_NULL\_BEHAVIOR
- SQL\_CURSOR\_COMMIT\_BEHAVIOR
- SQL\_CURSOR\_ROLLBACK\_BEHAVIOR
- SQL\_CURSOR\_SENSITIVITY
- SQL\_DATA\_SOURCE\_READ\_ONLY
- SQL\_DEFAULT\_TXN\_ISOLATION
- SQL\_DESCRIBE\_PARAMETER
- SQL\_MULT\_RESULT\_SETS
- SQL\_MULTIPLE\_ACTIVE\_TXN
- SQL\_NEED\_LONG\_DATA\_LEN
- SQL\_NULL\_COLLATION
- SQL\_PROCEDURE\_TERM
- SQL\_SCHEMA\_TERM
- SQL\_SCROLL\_OPTIONS
- SQL\_TABLE\_TERM
- SQL\_TXN\_CAPABLE
- SQL\_TXN\_ISOLATION\_OPTION
- SQL\_USER\_NAME

## Supported SQL

The following values of InfoType argument return Information on the SQL statements supported by the data source.

- SQL\_AGGREGATE\_FUNCTIONS
- SQL\_ALTER\_DOMAIN
- SQL\_ALTER\_SCHEMA
- SQL\_ALTER\_TABLE
- SQL\_ANSI\_SQL\_DATETIME\_LITERALS
- SQL\_CATALOG\_LOCATION
- SQL\_CATALOG\_NAME
- SQL\_CATALOG\_NAME\_SEPARATOR
- SQL\_CATALOG\_USAGE
- SQL\_COLUMN\_ALIAS
- SQL\_CORRELATION\_NAME
- SQL\_CREATE\_ASSERTION
- SQL\_CREATE\_CHARACTER\_SET
- SQL\_CREATE\_COLLATION
- SQL\_CREATE\_DOMAIN
- SQL\_CREATE\_SCHEMA
- SQL\_CREATE\_TABLE
- SQL\_CREATE\_TRANSLATION
- SQL\_DDL\_INDEX
- SQL\_DROP\_ASSERTION
- SQL\_DROP\_CHARACTER\_SET
- SQL\_DROP\_COLLATION
- SQL\_DROP\_DOMAIN
- SQL\_DROP\_SCHEMA
- SQL\_DROP\_TABLE
- SQL\_DROP\_TRANSLATION
- SQL\_DROP\_VIEW
- SQL\_EXPRESSIONS\_IN\_ORDERBY
- SQL\_GROUP\_BY
- SQL\_IDENTIFIER\_CASE
- SQL\_IDENTIFIER\_QUOTE\_CHAR
- SQL\_INDEX\_KEYWORDS
- SQL\_INSERT\_STATEMENT
- SQL\_INTEGRITY
- SQL\_KEYWORDS
- SQL\_LIKE\_ESCAPE\_CLAUSE
- SQL\_NON\_NULLABLE\_COLUMNS



- SQL\_SQL\_CONFORMANCE
- SQL\_OJ\_CAPABILITIES
- SQL\_ORDER\_BY\_COLUMNS\_IN\_SELECT
- SQL\_OUTER\_JOINS
- SQL\_PROCEDURES
- SQL\_QUOTED\_IDENTIFIER\_CASE
- SQL\_SCHEMA\_USAGE
- SQL\_SPECIAL\_CHARACTERS
- SQL\_SUBQUERIES
- SQL\_UNION

## SQL Restrictions

The following values of the InfoType argument return restrictions applied to identifiers and clauses in SQL statements, such as the maximum lengths of identifiers and the maximum number of columns in a select list. Restriction can be imposed by the driver or data source.

- SQL\_MAX\_BINARY\_LITERAL\_LEN
- SQL\_MAX\_CATALOG\_NAME\_LEN
- SQL\_MAX\_CHAR\_LITERAL\_LEN
- SQL\_MAX\_COLUMN\_NAME\_LEN
- SQL\_MAX\_COLUMNS\_IN\_GROUP\_BY
- SQL\_MAX\_COLUMNS\_IN\_INDEX
- SQL\_MAX\_COLUMNS\_IN\_ORDER\_BY
- SQL\_MAX\_COLUMNS\_IN\_SELECT
- SQL\_MAX\_COLUMNS\_IN\_TABLE
- SQL\_MAX\_CURSOR\_NAME\_LEN
- SQL\_MAX\_IDENTIFIER\_LEN
- SQL\_MAX\_INDEX\_SIZE
- SQL\_MAX\_PROCEDURE\_NAME\_LEN
- SQL\_MAX\_ROW\_SIZE
- SQL\_MAX\_ROW\_SIZE\_INCLUDES\_LONG
- SQL\_MAX\_SCHEMA\_NAME\_LEN
- SQL\_MAX\_STATEMENT\_LEN
- SQL\_MAX\_TABLE\_NAME\_LEN
- SQL\_MAX\_TABLES\_IN\_SELECT
- SQL\_MAX\_USER\_NAME\_LEN

## Scalar Function Information

The following values of InfoType argument return information on the scalar functions supported by the data source or driver.

- SQL\_CONVERT\_FUNCTIONS
- SQL\_NUMERIC\_FUNCTIONS
- SQL\_STRING\_FUNCTIONS
- SQL\_SYSTEM\_FUNCTIONS
- SQL\_TIMEDATE\_ADD\_INTERVALS
- SQL\_TIMEDATE\_DIFF\_INTERVALS
- SQL\_TIMEDATE\_FUNCTIONS

## Conversion Information

The following values of InfoType argument return the list of SQL data types of which the data source can be converted to the specified SQL data type with CONVERT scalar function.

- SQL\_CONVERT\_BIGINT
- SQL\_CONVERT\_BINARY
- SQL\_CONVERT\_BIT
- SQL\_CONVERT\_CHAR
- SQL\_CONVERT\_DATE
- SQL\_CONVERT\_DECIMAL
- SQL\_CONVERT\_DOUBLE
- SQL\_CONVERT\_FLOAT
- SQL\_CONVERT\_INTEGER
- SQL\_CONVERT\_INTERVAL\_YEAR\_MONTH
- SQL\_CONVERT\_INTERVAL\_DAY\_TIME
- SQL\_CONVERT\_LONGVARBINARY
- SQL\_CONVERT\_LONGVARCHAR
- SQL\_CONVERT\_NUMERIC
- SQL\_CONVERT\_REAL
- SQL\_CONVERT\_SMALLINT
- SQL\_CONVERT\_TIME
- SQL\_CONVERT\_TIMESTAMP
- SQL\_CONVERT\_TINYINT
- SQL\_CONVERT\_VARBINARY
- SQL\_CONVERT\_VARCHAR

## Added Information Type in ODBC 3.x

The following values of InfoType argument are added to ODBC 3.x.

- SQL\_ACTIVE\_ENVIRONMENTS
- SQL\_AGGREGATE\_FUNCTIONS
- SQL\_ALTER\_DOMAIN

- SQL\_ALTER\_SCHEMA
- SQL\_ANSI\_SQL\_DATETIME\_LITERALS
- SQL\_ASYNC\_DBC\_FUNCTIONS
- SQL\_ASYNC\_MODE
- SQL\_ASYNC\_NOTIFICATION
- SQL\_BATCH\_ROW\_COUNT
- SQL\_BATCH\_SUPPORT
- SQL\_CATALOG\_NAME
- SQL\_COLLATION\_SEQ
- SQL\_CONVERT\_INTERVAL\_YEAR\_MONTH
- SQL\_CONVERT\_INTERVAL\_DAY\_TIME
- SQL\_CREATE\_ASSERTION
- SQL\_CREATE\_CHARACTER\_SET
- SQL\_CREATE\_COLLATION
- SQL\_CREATE\_DOMAIN
- SQL\_CREATE\_SCHEMA
- SQL\_CREATE\_TABLE
- SQL\_CREATE\_TRANSLATION
- SQL\_CURSOR\_SENSITIVITY
- SQL\_DDL\_INDEX
- SQL\_DESCRIBE\_PARAMETER
- SQL\_DM\_VER
- SQL\_DRIVER\_AWARE\_POOLING\_SUPPORTED
- SQL\_DRIVER\_HDESC
- SQL\_DROP\_ASSERTION
- SQL\_DROP\_CHARACTER\_SET
- SQL\_DROP\_COLLATION
- SQL\_DROP\_DOMAIN
- SQL\_DROP\_SCHEMA
- SQL\_DROP\_TABLE
- SQL\_DROP\_TRANSLATION
- SQL\_DROP\_VIEW
- SQL\_DYNAMIC\_CURSOR\_ATTRIBUTES1
- SQL\_DYNAMIC\_CURSOR\_ATTRIBUTES2
- SQL\_FORWARD\_ONLY\_CURSOR\_ATTRIBUTES1
- SQL\_FORWARD\_ONLY\_CURSOR\_ATTRIBUTES2
- SQL\_INFO\_SCHEMA\_VIEWS
- SQL\_INSERT\_STATEMENT
- SQL\_KEYSET\_CURSOR\_ATTRIBUTES1
- SQL\_KEYSET\_CURSOR\_ATTRIBUTES2
- SQL\_MAX\_ASYNC\_CONCURRENT\_STATEMENTS

- SQL\_MAX\_IDENTIFIER\_LEN
- SQL\_PARAM\_ARRAY\_ROW\_COUNTS
- SQL\_PARAM\_ARRAY\_SELECTS
- SQL\_STATIC\_CURSOR\_ATTRIBUTES1
- SQL\_STATIC\_CURSOR\_ATTRIBUTES2
- SQL\_XOPEN\_CLI\_YEAR

## Renamed Information Type in ODBC 3.x

The following values of InfoType argument are renamed for ODBC 3.x.

- SQL\_ACTIVE\_CONNECTIONS: SQL\_MAX\_DRIVER\_CONNECTIONS
- SQL\_ACTIVE\_STATEMENTS: SQL\_MAX\_CONCURRENT\_ACTIVITIES
- SQL\_MAX\_OWNER\_NAME\_LEN: SQL\_MAX\_SCHEMA\_NAME\_LEN
- SQL\_MAX\_QUALIFIER\_NAME\_LEN: SQL\_MAX\_CATALOG\_NAME\_LEN
- SQL\_ODBC\_SQL\_OPT\_IEF: SQL\_INTEGRITY
- SQL\_OWNER\_TERM: SQL\_SCHEMA\_TERM
- SQL\_OWNER\_USAGE: SQL\_SCHEMA\_USAGE
- SQL\_QUALIFIER\_LOCATION: SQL\_CATALOG\_LOCATION
- SQL\_QUALIFIER\_NAME\_SEPARATOR: SQL\_CATALOG\_NAME\_SEPARATOR
- SQL\_QUALIFIER\_TERM: SQL\_CATALOG\_TERM
- SQL\_QUALIFIER\_USAGE: SQL\_CATALOG\_USAGE

## Deprecated Information Type in ODBC 3.x

The following InfoType argument values are information types which are deprecated in ODBC 3.x driver but are still supported for compatibility with ODBC 2.x applications.

- SQL\_FETCH\_DIRECTION
- SQL\_LOCK\_TYPES
- SQL\_ODBC\_API\_CONFORMANCE
- SQL\_ODBC\_SQL\_CONFORMANCE
- SQL\_POS\_OPERATIONS
- SQL\_POSITIONED\_STATEMENTS
- SQL\_SCROLL\_CONCURRENCY
- SQL\_STATIC\_SENSITIVITY

# SQLGetStmtAttr

## Conformance

Introduced version: ODBC 3.0

Standards compliance: ISO 92

## Overview

SQLGetStmtAttr returns the current setting of the statement attribute.

## Syntax

```
SQLRETURN SQLGetStmtAttr(  
    SQLHSTMT      StatementHandle,  
    SQLINTEGER    Attribute,  
    SQLPOINTER    ValuePtr,  
    SQLINTEGER    BufferLength,  
    SQLINTEGER *  StringLengthPtr);
```

## Arguments

### StatementHandle

[Input] It is the statement handle.

### Attribute

[Input] It is the attribute to be retrieved.

### ValuePtr

[Output] It is the buffer pointer in which to return the attribute value specified in Attribute. If ValuePtr is NULL, StringLengthPtr returns the total number of bytes returnable to the buffer pointed by ValuePtr (excluding null-termination character).

### BufferLength

[Input] If Attribute is the attribute defined in ODBC and ValuePtr points to a string or binary buffer, the argument is the length of \*ValuePtr. If Attribute is the attribute defined in ODBC and \*ValuePtr is an integer, BufferLength is ignored. If \*ValuePtr (when SQLGetStmtAttrW is called) is a unicode string, BufferLength should be an even number.

If Attribute is the driver defined attribute, the application displays the attribute characteristic to the driver manager by setting BufferLength argument. BufferLength has one of the following values.

- If \*ValuePtr is a string pointer, BufferLength is the string length or SQL\_NTS.
- If \*ValuePtr is a binary buffer pointer, the application stores SQL\_LEN\_BINARY\_ATTR (length) macro result in BufferLength. It stores a negative number in BufferLength.
- If \*ValuePtr is a pointer of the value other than a string or a binary string, BufferLength has the value of SQL\_IS\_POINTER.
- If \*ValuePtr has the fixed length data type, BufferLength has SQL\_IS\_INTEGER or SQL\_IS\_UNSIGNED.

### StringLengthPtr

[Output] It is the buffer pointer which returns the total number of bytes returnable to \*ValuePtr (excluding null-termination character). If ValuePtr is null, the length is not returned. If the attribute value is a string and the bytes returnable is equal to or bigger than BufferLength, the data in \*ValuePtr is truncated to the length of BufferLength minus the null-termination character, and it is null-terminated by the driver).

## Returns

SQL\_SUCCESS, SQL\_SUCCESS\_WITH\_INFO, SQL\_ERROR, SQL\_INVALID\_HANDLE

## Diagnosis

SQLSTATE	Error	Description
01000	General warning	It is the driver-specific informational message. (The function returns SQL_SUCCESS_WITH_INFO.)
01004	String data, right truncated	The data returned to *ValuePtr is truncated to the length of BufferLength minus null-termination character. The untruncated string value is returned in *StringLengthPtr. (The function returns SQL_SUCCESS_WITH_INFO.)
24000	Invalid cursor state	Attribute argument is SQL_ATTR_ROW_NUMBER, and the cursor is not open or the cursor is positioned before or after the result set.
HY000	General error	It is an error without any specific SQLSTATE.
HY001	Memory allocation error	It is a memory allocation error.
HY010	Function sequence error	<p>The asynchronously executing function is called for the connection handle related to StatementHandle, and this function is still being executed when SQLGetStmtAttr is called.</p> <p>The asynchronously executing function is called for StatementHandle, and is still being executed when the function is called.</p> <p>SQLExecute, SQLExecDirect, SQLBulkOperation or SQLSetPos are called for StatementHandle, and SQL_NEED_DATA is returned. This function</p>

SQLSTATE	Error	Description
		n is called before data is sent for all data-at-execution parameters or columns.
HY013	Memory management error	The size of buffer used as an argument is smaller than 0, or it can not access the memory.
HY090	Invalid string or buffer length	*ValuePtr is a string, and BufferLength is smaller than 0 but it is not equal to SQL_NTS.
HY092	Invalid attribute/option identifier	The specified value of Attribute argument is not valid for ODBC version supported by the driver.
HY109	Invalid cursor position	Attribute argument is SQL_ATTR_ROW_NUMBER, and the row is deleted or can not be retrieved.
HY117	Connection is suspended due to unknown transaction state. Only disconnect and read-only functions are allowed.	For more information about the suspended state, refer to <b>SQLEndTran</b> .
HYC00	Optional field not implemented	The value specified in attribute argument is valid ODBC statement attribute in ODBC version supported by the driver, but it is not supported by the driver.
HYT01	Connection timeout expired	The connection is expired before the data source responds to the request. The timeout can be set via SQL_ATTR_CONNECTION_TIMEOUT of SQLSetStmtAttr.
IM001	Driver does not support this function	The driver which is related to DescriptorHandle does not support the function.

## Description

SQLGetStmtAttr returns the statement attribute value specified in Attribute to \*ValuePtr. The value returned can be the SQLULEN value or null-termination string. If the value is SQLULEN, some drivers write the lower 32 bits or 16 bits of the buffer and keep the upper bits as they are. Therefore, the application should use the buffer of SQLULEN and initialize it to 0 before the function is called. Also BufferLength and StringLengthPtr are not used. If the value is the null termination string, the application specifies the maximum string length of BufferLength argument, and the driver returns the string length to \*StringLengthPtr buffer.

If an application which is operated with ODBC 2.x driver wants to call SQLGetStmtAttr, SQLGetStmtAttr should be mapped to the SQLGetStmtOption of the driver manager.

The following statement can be retrieved by SQLGetStmtAttr but it can not set by SQLSetStmtAttr because the attributes are read-only.

- SQL\_ATTR\_IMP\_PARAM\_DESC

- SQL\_ATTR\_IMP\_ROW\_DESC
- SQL\_ATTR\_ROW\_NUMBER

## Statement Attributes

The following table describes currently defined attributes and its introduced ODBC version.

Attribute	ValuePtr contents
SQL_ATTR_APP_PARAM_DESC (ODBC 3.0)	<p>It is the APD handle for the time after calling SQLExecute and SQLExecDirect on the statement handle. The initial value of this attribute is the descriptor implicitly allocated when the statement is initially allocated. If the value of this attribute is set to the descriptor which is originally allocated by SQL_NULL_DESC or the handle, an explicitly allocated APD handle which is previously related to the statement handle is detached from it and the statement handle is returned to the implicitly allocated APD handle.</p> <p>This attribute can not be set to a descriptor handle which is implicitly allocated for another statement, nor set to another descriptor handle which is implicitly allocated for the same statement. The implicitly allocated descriptor handles cannot be related to a statement or a descriptor handle.</p>
SQL_ATTR_APP_ROW_DESC (ODBC 3.0)	<p>It is the ARD handle for the next fetches of the statement handle. The initial value of the attribute is the descriptor implicitly allocated when the statement is initially allocated. If the attribute is set to SQL_NULL_DESC or to the descriptor allocated by the handle, ARD handle which is explicitly allocated and related to the previous statement is detached and the statement handle is returned to ARD handle implicitly allocated.</p> <p>The attribute can not be set to a descriptor handle which is implicitly allocated for another statement, nor set to another descriptor handle which is implicitly set on the same statement. The implicitly allocated descriptor handle can not be related to a statement or descriptor handle.</p>
SQL_ATTR_ASYNC_ENABLE (ODBC 1.0)	<p>It is not supported by the driver.</p>
SQL_ATTR_ASYNC_STMT_EVENT (ODBC 3.8)	<p>It is not supported by the driver.</p>
SQL_ATTR_ASYNC_STMT_PCALLBACK (ODBC3.8)	<p>It is not supported by the driver.</p>
SQL_ATTR_ASYNC_STMT_PCONTEXT (ODBC 3.8)	<p>It is not supported by the driver.</p>
	<ul style="list-style-type: none"> <li>• SQLULEN: It is the value which specifies the concurrency of cursor.</li> <li>• SQL_CONCUR_READ_ONLY: The cursor is read-only, and the update is not allowed.</li> </ul>



Attribute	ValuePtr contents
SQL_ATTR_CONCURRENCY (ODBC 2.0)	<ul style="list-style-type: none"> <li>• SQL_CONCUR_LOCK: The cursor uses the locking of the minimum level which is enough to complete update the row.</li> <li>• SQL_CONCUR_POWER: The cursor uses the concurrency which controls and compares the row version such as SQLBase ROWID or Sybase TIMESTAMP.</li> <li>• SQL_CONCUR_VALUES: The cursor uses the concurrency which controls and compares the value.</li> </ul> <p>The default value of SQL_ATTR_CONCURRENCY is SQL_CONCUR_READ_ONLY.</p> <p>If the Attribute of SQL_ATTR_CURSOR_TYPE is changed to the value not supported by SQL_ATTR_CONCURRENCY, then the value of SQL_ATTR_CONCURRENCY is changed at the execution time, and the warning will be issued when SQLExecDirect or SQLPrepare is called.</p> <p>If SQL_ATTR_CONCURRENCY is changed to SQL_CONCUR_READ_ONLY, while the driver supports and executes SELECT FOR UPDATE statement, then an error is returned. If SQL_ATTR_CONCURRENCY value is changed to SQL_ATTR_CURSOR_TYPE value supported by the driver or the value not supported, SQL_ATTR_CURSOR_TYPE value is changed at the execution time, SQLSTATE 01S02 (Option value changed) is issued when SQLExecDirect or SQLPrepare is executed.</p> <p>If the specified concurrency is not supported in the data source, the driver replaces it with another concurrency and returns SQLSTATE 01S02 (Option value changed). The driver replaces SQL_CONCUR_VALUES with SQL_CONCUR_ROWVER, or vice versa. Also SQL_CONCUR_LOCK is replaced with SQL_CONCUR_ROWVER, SQL_CONCUR_VALUES in order. The validity of the replaced value is not confirmed until the execution time.</p>
SQL_ATTR_CURSOR_SCROLLABLE (ODBC 3.0)	<ul style="list-style-type: none"> <li>• SQL_NONSCROLLABLE: It is the default value. The scroll cursor is not required in the statement handle. If the application calls SQLFetchScroll on the handle, the only valid value of FetchOrientation is SQL_FETCH_NEXT.</li> <li>• SQLULEN: It is the value which specifies the required support level of the application. Setting the attribute affects the following SQLExecDirect and SQLExecute.</li> <li>• SQL_SCROLLABLE: The scroll cursor is required in the statement handle. When SQLFetchScroll is called, the application positions the cursor in a mode except sequential mode and specify a valid value of FetchOrientation.</li> </ul>
SQL_ATTR_CURSOR_SENSITIVITY	<ul style="list-style-type: none"> <li>• SQL_UNSPECIFIED: It is the default value. It is unspecified what the cursor type is and whether cursors on the statement handle can view the changes made to a result set by another cursor. The cursor of the statement handle probably view is none, some, or all.</li> <li>• SQLULEN: It is the value which determines whether the cursor of the statement handle can view a change in the result set generated by another cursor. Setting</li> </ul>

Attribute	ValuePtr contents
(ODBC 3.0)	<p>the attribute affects the following SQLExecDirect and SQLExecute. The application can read the attribute again to obtain the initial state or state most recently set by the application.</p> <ul style="list-style-type: none"> <li>• SQL_INSENSITIVE: All cursors of the statement handle can not view the reflection of any changes made by another cursor and they can view only the results. The insensitive cursor is read-only. It corresponds to a static cursor with a read-only concurrency.</li> <li>• SQL_SENSITIVE: All cursors of the statement handle can view all changes in the result set.</li> </ul>
SQL_ATTR_CURSOR_TYPE (ODBC 2.0)	<ul style="list-style-type: none"> <li>• SQLULEN: It is the value which specifies the cursor type.</li> <li>• SQL_CURSOR_FORWARD_ONLY: The cursor can only move forward.</li> <li>• SQL_CURSOR_KEYSET_DRIVEN: The driver stores and uses keys as many as the number of rows specified in SQL_ATTR_KEYSET_SIZE which is the statement attribute.</li> <li>• SQL_CURSOR_DYNAMIC: The driver stores and uses the key for the row in the row set.</li> </ul> <p>The default value is SQL_CURSOR_FORWARD_ONLY. The attribute can not be specified in the prepared SQL statement.</p> <p>If the specified cursor type is not supported by the data source, then the driver replaces it with other type and returns SQLSTATE 01S02 (Option value changed). The driver replaces a mixed or dynamic cursor with a key set-driven or static cursor. The driver replaces a key set-driven cursor with a static cursor.</p>
SQL_ATTR_ENABLE_AUTO_IPD (ODBC 3.0)	It is not supported by the driver.
SQL_ATTR_FETCH_BOOKMARK_PTR (ODBC 3.0)	It is not supported by the driver.
SQL_ATTR_IMP_PARAM_DESCRIPTOR (ODBC 3.0)	<p>It is the handle of IPD. This attribute value is the descriptor allocated when the statement is initially allocated. The application can not set the attribute.</p> <p>The attribute can be retrieved by calling SQLGetStmtAttr, but it can not be set via SQLSetStmtAttr.</p>
SQL_ATTR_IMP_ROW_DESCRIPTOR (ODBC 3.0)	<p>It is the handle of IRD. This attribute value is the descriptor allocated when the statement is initially allocated. The application can not set the attribute.</p> <p>The attribute can be retrieved by calling SQLGetStmtAttr, but it can not be set via SQLSetStmtAttr.</p>
SQL_ATTR_KEYSET_SIZE	

Attribute	ValuePtr contents
(ODBC 2.0)	It is not supported by the driver.
SQL_ATTR_MAX_LENGTH (ODBC 1.0)	It is not supported by the driver.
SQL_ATTR_MAX_ROWS (ODBC 1.0)	<ul style="list-style-type: none"> <li>SQLULEN: It is the value which corresponds to the maximum number of rows which are returned from SELECT statement. If *ValuePtr is equal to 0, the driver returns all rows.</li> </ul> <p>The attribute is intended to reduce the network traffic. Notionally it is applied when the result set is generated, it limits the result set of the first ValuePtr row. If the number of rows in the result set are bigger than ValuePtr, then the result set is reduced.</p> <p>SQL_ATTR_MAX_ROWS includes those which are applied to all result set of the statement and returned by the catalog function.</p> <p>SQL_ATTR_MAX_ROWS sets the maximum number of the cursor rows.</p> <p>If SQL_ATTR_MAX_ROWS can not be guaranteed to be correctly implemented (if the result set size limit can not be implemented in the data source), then the driver should not imitate SQL_ATTR_MAX_ROWS operation for SQLFetch or SQLFetchScroll.</p> <p>The driver defines whether to apply SQL_ATTR_MAX_ROWS to the statements except for SELECT statement(such as the catalog functions).</p> <p>The attribute can be set in the open cursor. However, it does not immediately bring the effect. In this case, the driver returns SQLSTATE 01S02 (Option value changed) and sets the attribute to its original value.</p>
SQL_ATTR_METADATA_ID (ODBC 3.0)	<ul style="list-style-type: none"> <li>SQLULEN: It is the value which determines how to treat the string arguments of the catalog functions.</li> </ul> <p>If it is SQL_TRUE, the catalog functions treat the string arguments as the identifiers. In this case, it is not case sensitive. The driver removes the trailing spaces and converts to uppercase for the string whose scope is not defined. The driver removes the leading and trailing spaces and literally takes the string between the delimiters for the string whose scope is defined. If one of the arguments is set to NULL pointer, the function returns SQL_ERROR and SQLSTATE HY009 (Invalid use of null pointer).</p> <p>If it is SQL_FALSE, the catalog functions do not treat the string arguments as the identifiers. In this case, it is case sensitive. The arguments may or may not include a string search pattern depending on the argument.</p> <p>The default value is SQL_FALSE.</p> <p>The list of values of TableType argument of SQLTables is not affected by the attribute.</p> <p>SQL_ATTR_METADATA_ID can be set on the connection level.(SQL_ATTR_METADATA_ID</p>

Attribute	ValuePtr contents
	<p>A_ID and SQL_ATTR_ASYNC_ENABLE are unique and they are the statement attributes and connection attributes.)</p> <p>For more information, refer to <b>Arguments of Catalog Function</b>.</p>
SQL_ATTR_NOSCAN (ODBC 1.0)	It is not supported by the driver.
SQL_ATTR_PARAM_BIND_OFFSET_PTR (ODBC 3.0)	<ul style="list-style-type: none"> <li>SQLULEN*: It is the value which points to the offset to add a pointer to change the dynamic parameter binding. If the field is not NULL, the driver dereferences the pointer, and additionally it dereferences each value of the deferred fields in the descriptor record(SQL_DESC_DATA_PTR, SQL_DESC_INDICATOR_PTR, SQL_DESC_OCTET_LENGTH_PTR) and it uses the new pointer values when bound. It is set to NULL by default.</li> </ul> <p>The bind offset is always directly added to SQL_DESC_DATA_PTR, SQL_DESC_INDICATOR_PTR, SQL_DESC_OCTET_LENGTH_PTR fields. If the offset is changed to another value, the new value is directly added to the descriptor field value. The new offset will not be added to any previous offset value in the field.</p> <p>SQL_DESC_BIND TYPE field in APD header is set by setting this statement attribute.</p>
SQL_ATTR_PARAM_BIND_TYPE (ODBC 3.0)	<ul style="list-style-type: none"> <li>SQLULEN: It is the value which refers to the binding direction used in the dynamic parameter.</li> </ul> <p>This field is set to SQL_PARAM_BIND_BY_COLUMN which selects the column-wise binding. (default value)</p> <p>The field is set to the instance of the buffer to be bound to the structure length or dynamic parameter set to select the row-wise binding. This length should include the space for all bound parameters and the structure padding, or the address of the binding parameter is increased to the specified length, then the result should be buffered to point to the beginning of the next parameter. The sizeof operation of ANSI C guarantees this behavior.</p> <p>SQL_DESC_BIND_TYPE field in APD header is set by setting this statement attribute.</p>
SQL_ATTR_PARAM_OPERATION_PTR (ODBC 3.0)	<ul style="list-style-type: none"> <li>SQLUSMALLINT*: It is the value which points to the array of SQLSMALLINT values used to ignore the parameter while executing the SQL statement. Each value is SQL_PARAM_PROCEED(to execute the parameter) or SQL_PARAM_IGNORE(to ignore the parameter).</li> </ul> <p>The parameter set can be ignored during processing by setting the status value of the array pointed by SQL_DESC_ARRAY_STATUS_PTR in APD. The parameter set is processed when the status value is SQL_PARAM_PROCEED or the array elements are not set.</p> <p>The statement attribute can be set to a NULL pointer and the driver does not return the status value of the parameter. The attribute can be set at any time but the new value</p>

Attribute	ValuePtr contents
	<p>e is not used until SQLExecDirect or SQLExecute is called.</p> <p>The attribute is ignored if bound parameter does not exist.</p> <p>SQL_DESC_ARRAY_STATUS_PTR field in APD header is set by setting this statement attribute.</p>
<p>SQL_ATTR_PARAM_STATUS_PTR (ODBC 3.0)</p>	<ul style="list-style-type: none"> <li>• SQLUSMALLINT*: It is the value points to SQLUSMALLINT array which includes the status information value of each row parameter value after calling SQLExecute or SQLExecDirect. The field is required only when PARAMSET_SIZE is bigger than 1. The status value can include other values.</li> <li>• SQL_PARAM_SUCCESS: SQL statement is successfully executed for the parameter set</li> <li>• SQL_PARAM_SUCCESS_WITH_INFO: SQL statement is successfully executed for the parameter set but the warning information exists in the diagnostic data structure.</li> <li>• SQL_PARAM_ERROR: An error occurs when processing the parameter set. The additional error information is in the diagnostic data structure.</li> <li>• SQL_PARAM_UNUSED: The parameter set is not used because some previous parameter set caused an error which interrupts the processing, or the parameter set of the array specified by SQL_ATTR_PARAM_OPERATION_PTR is set to SQL_PARAM_IGNORE.</li> <li>• SQL_PARAM_DIAG_UNAVAILABLE: The driver treats the parameter array as a uniform unit because the error information level is not generated.</li> </ul> <p>The statement attribute can be set to a NULL pointer and the driver does not return the status value of the parameter. The attribute can always be set. But the new value is not used until SQLExecDirect or SQLExecute is called. The attribute may affect the operation that the parameter outputs in the driver.</p> <p>SQL_DESC_ARRAY_STATUS_PTR field of IPD header is set by setting this statement attribute.</p>
<p>SQL_ATTR_PARAMS_PROCESSED_PTR (ODBC 3.0)</p>	<ul style="list-style-type: none"> <li>• SQLULEN*: It is the record field pointing to the buffer in which to return the number of parameter sets processed and it includes the error set. If it is a NULL pointer, any number will not be returned.</li> </ul> <p>SQL_DESC_ROWS_PROCESSED_PTR field of IPD is set by setting this statement attribute.</p> <p>If SQLExecDirect or SQLExecute which will fill the buffer specified in this attribute does not return SQL_SUCCESS or SQL_SUCCESS_WITH_INFO, the buffer content is not defined.</p>

Attribute	ValuePtr contents
SQL_ATTR_PARAMSET_SIZE (ODBC 3.0)	<ul style="list-style-type: none"> <li>SQLULEN: It is the value which specifies the number of each parameter values. If SQL_ATTR_PARAMSET_SIZE is bigger than 1, then SQL_DESC_DATA_PTR, SQL_DESC_INDICATOR_PTR, SQL_DESC_OCTET_LENGTH_PTR of APD points to the array. Each array constant is equal to the field value.</li> </ul> <p>If binding parameter does not exist, this attribute is ignored.</p> <p>SQL_DESC_ARRAY_SIZE field of APD header is set by setting the statement attribute.</p>
SQL_ATTR_QUERY_TIMEOUT (ODBC 1.0)	<ul style="list-style-type: none"> <li>SQLULEN: It is the value which value in seconds which wait for the SQL statement to execute before returning to the application. If ValuePtr is 0(default value), the timeout does not occur.</li> </ul> <p>If the specified timeout value exceeds the maximum value of the data source or it is smaller than the minimum value, then SQLSetStmtAttr replaces the value and returns SQLSTATE 01S02 (Option value changed).</p> <p>Even if SELECT statement is timed out, SQLCloseCursor does not need to be called when reuse the statement.</p> <p>It is valid to set the query timeout of the statement attribute for both synchronous and asynchronous mode.</p>
SQL_ATTR_RETRIEVE_DATA (ODBC 2.0)	<p>It is not supported by the driver.</p>
SQL_ATTR_ROW_ARRAY_SIZE (ODBC 3.0)	<ul style="list-style-type: none"> <li>SQLULEN: It is the value which points to the number of rows returned by calling each SQLFetch or SQLFetchScroll. It is also the number of rows of the bookmark array used in a bulk bookmark operation in SQLBulkOperations. The default value is 1.</li> </ul> <p>If the specified row set size exceeds the row set size supported by the data source, the driver replaces the value and returns SQLSTATE 01S02 (option value changed).</p> <p>SQL_DESC_ARRAY_SIZE field of ARD header is set by setting this statement attribute.</p>
SQL_ATTR_ROW_BIND_OFFSET_PTR (ODBC 3.0)	<ul style="list-style-type: none"> <li>SQLULEN: It is the value which points to the offset added to pointers to change binding of the column data. If the field is not NULL, the driver dereferences the pointer and adds the value dereferenced to each field of the descriptor record (SQL_DESC_DATA_PTR, SQL_DESC_INDICATOR_PTR, SQL_DESC_OCTET_LENGTH_PTR), and it uses the new pointer value when binding occurs. The default value is NULL.</li> </ul> <p>SQL_DESC_BIND_OFFSET_PTR field of ARD header is set by setting the statement attribute.</p>
	<ul style="list-style-type: none"> <li>SQLULEN: It is the value which sets the binding direction when SQLFetch or SQL</li> </ul>

Attribute	ValuePtr contents
SQL_ATTR_ROW_BIND_TYPE (ODBC 1.0)	<p>FetchScroll is called in the related statement. If SQL_BIND_BY_COLUMN is set, the column-wise binding is selected. If the structure or result column sets the length for an instance of the buffer bound, then the row-wise binding is selected.</p> <p>If the length is specified and the address of the all columns and bound columns are increased to the specified length, then all columns should include enough space for the structure or the buffer padding. The behavior is guaranteed when sizeof operator is used with the structure or union in ANSI C.</p> <p>The column-wise binding is the default binding direction of SQLFetch and SQLFetchScroll.</p> <p>SQL_DESC_BIND_TYPE field of ARD header is set by setting this statement attribute.</p>
SQL_ATTR_ROW_NUMBER (ODBC 2.0)	<ul style="list-style-type: none"> <li>SQLULEN: It is the current row order in the entire result set. If the number of the current rows can not be determined or the the current row does not exist, then the driver returns 0.</li> </ul> <p>The attribute can be retrieved by calling SQLGetStmtAttr. It can not be set by calling SQLSetStmtAttr.</p>
SQL_ATTR_ROW_OPERATION_PTR (ODBC 3.0)	<p>It is not supported by the driver.</p>
SQL_ATTR_ROW_STATUS_PTR (ODBC 3.0)	<ul style="list-style-type: none"> <li>SQLUSMALLINT*: It is the value which points to SQLUSMALLINT array containing the status values after calling SQLFetch or SQLFetchScroll. The array has the elements as many as the number of rows in the row set.</li> </ul> <p>The statement attribute can be set to a NULL pointer, and in this case the driver does not return the row status value. The attribute can be set at any time but the new value is not used until the next SQLBulkOperations, SQLFetch, SQLFetchScroll or SQLSetPos is called.</p> <p>SQL_DESC_ARRAY_STATUS_PTR field of IRD header is set by setting the statement attribute.</p> <p>The attribute is mapped to rgbRowStatus array of SQLExtendedFetch in ODBC 2.x driver.</p>
SQL_ATTR_ROWS_FETCHED_PTR (ODBC 3.0)	<ul style="list-style-type: none"> <li>SQLULEN*: It points to the buffer which returns the number of collected rows after calling SQLFetch or SQLFetchScroll. The number of rows are determined by calling SQLSetPos by setting SQL_REFRESH in operation argument, or determined by processing the bulk operation via SQLBulkOperations. The number of rows include the error rows.</li> </ul> <p>SQL_DESC_ROWS_PROCESSED_PTR field of IRD header is set by setting the statement attribute.</p>

Attribute	ValuePtr contents
	<p>the attribute.</p> <p>If calling SQLFetch or SQLFetchScroll which fills in the buffer pointed by the attribute does not return SQL_SUCCESS or SQL_SUCCESS_WITH_INFO, the buffer content is not defined.</p>
SQL_ATTR_SIMULATE_CURSOR (ODBC 2.0)	It is not supported by the driver.
SQL_ATTR_USE_BOOKMARKS (ODBC 2.0)	It is not supported by the driver.



# SQLGetStmtOption

## Conformance

Introduced version: ODBC 1.0

Standards compliance: It is not available.

## Overview

In ODBC 3.x, SQLGetStmtOption function is replaced with SQLGetStmtAttr function.

For more information, refer to **SQLGetStmtAttr**.

# SQLGetSuitableGroupID

## Conformance

Standards compliance: It is not available.

## Overview

SQLGetSuitableGroupID returns the ID of the cluster group which is the most suitable for the prepared statement to perform in cluster system.

## Syntax

```
SQLRETURN SQLGetSuitableGroupID(
    SQLHSTMT      StatementHandle,
    SQLINTEGER *  GroupIDPtr );
```

## Arguments

### ConnectionHandle

[Input] It is the connection handle.

### GroupIDPtr

[Output] It is the ID of the cluster group.

## Returns

SQL\_SUCCESS, SQL\_ERROR, SQL\_INVALID\_HANDLE

## Diagnosis

SQLSTATE	Error	Description
08S01	Communication link failure	Before the function processing is completed, the connection between the driver and the data source is failed.
HY010	Function sequence error	This function is called before SQLPrepare.  This function should be called only when the connection property SQL_ATTR_LOCALITY_AWARE_TRANSACTION is set.

## Description

SQLGetSuitableGroupID can be called only when the connection property SQL\_ATTR\_LOCALITY\_AWARE\_TRANSACTION is set and the statement is prepared.

SQLGetSuitableGroupID returns the ID of the cluster group which is the most suitable for the prepared statement to perform in cluster system by using the current value of the parameter marker when the parameter exists in the statement. If the cluster group which is the most suitable for the prepared statement to perform can not be determined, then it returns SQL\_INVALID\_GROUP\_ID(-1).

# SQLGetTypeInfo

## Conformance

Introduced version: ODBC 1.0

Standards compliance: ISO 92

## Overview

SQLGetTypeInfo returns the information of data type supported by the data source. The driver returns information in the form of SQL result set. Data types are used for Data Definition Language (DDL).

## Syntax

```
SQLRETURN SQLGetTypeInfo(
    SQLHSTMT      StatementHandle,
    SQLSMALLINT   DataType);
```

## Arguments

### StatementHandle

[Input] It is the statement handle for the result set.

### DataType

[Input] It is the SQL data type. It is data type or the specified driver SQL data type. SQL\_ALL\_TYPES specifies that the information about all data types should be returned.

## Returns

SQL\_SUCCESS, SQL\_SUCCESS\_WITH\_INFO, SQL\_STILL\_EXECUTING, SQL\_ERROR, SQL\_INVALID\_HANDLE

## Diagnosis

SQLSTATE	Error	Description
01000	General Warning	It is the driver-specific informational message. (The function returns SQL_SUCCESS_WITH_INFO.)
		It is temporarily replaced with the similar value because the specified statement attribute is invalid due to implementation working condition. Th

SQLSTATE	Error	Description
01S02	Option value changed	<p>e replaced value is valid for StatementHandle until the cursor is closed.</p> <p>The updatable statement attributes are as follows.  SQL_ATTR_CONCURRENCY, SQL_ATTR_CURSOR_TYPE,  SQL_ATTR_KEYSET_SIZE, SQL_ATTR_MAX_LENGTH, SQL_ATTR_MAX_ROWS,  SQL_ATTR_QUERY_TIMEOUT, SQL_ATTR_SIMULATE_CURSOR.  (The function returns SQL_SUCCESS_WITH_INFO.)</p>
08S01	Communication link failure	Before the function processing is completed, the connection between the driver and the data source is failed.
24000	Invalid cursor state	<p>The cursor is open in StatementHandle, and SQLFetch or SQLFetchScroll is called.</p> <p>If SQLFetch or SQLFetchScroll returns SQL_NO_DATA, the driver returns this error. If SQLFetch or SQLFetchScroll does not return SQL_NO_DATA, the driver manager returns this error.</p> <p>The result set is open in StatementHandle, but SQLFetch or SQLFetchScroll is not called.</p>
40001	Serialization failure	The transaction is rolled back due to a resource deadlock of other transactions.
40003	Statement completion unknown	The related connection fails during the function execution and the status of the transaction is not able to be checked.
HY000	General error	It is an error without any specific SQLSTATE.
HY001	Memory allocation error	It is a memory allocation error.
HY004	Invalid SQL data type	The value which is specified in DataType argument is neither ODBC SQL data type identifier supported by the driver nor the driver-specific data type identifier.
HY008	Operation canceled	<p>Asynchronous processing for StatementHandle is available and SQLCancel or SQLCancelHandle is called on StatementHandle before the function is called and completed. Then this function is called again on StatementHandle.</p> <p>SQLCancel or SQLCancelHandle is called on StatementHandle from other thread in the multithreaded application before the function is called and completed.</p>
HY010	Function sequence error	<p>The asynchronously executing function is called for the connection handle related to StatementHandle, but it is still being asynchronously executed when SQLGetStmtAttr is called.</p> <p>The asynchronously executing function is called for the StatementHandle, it is still being asynchronously executed when the function is called.</p> <p>SQLExecute, SQLExecDirect, SQLBulkOperation or SQLSetPos is called f</p>

SQLSTATE	Error	Description
		or StatementHandle, and SQL_NEED_DATA is returned. This function is called before data is sent for all data-at-execution parameters or columns.
HY013	Memory management error	The size of buffer used as an argument is smaller than 0, or it can not access the memory.
HY117	Connection is suspended due to unknown transaction state. Only disconnect and read-only functions are allowed.	For more information about the suspended state, refer to <b>SQLEndTran</b> .
HYC00	Optional field not implemented	The combination for the current setting of SQL_ATTR_CONCURRENCY and SQL_ATTR_CURSOR_TYPE statement attributes is not supported by the driver or by the data source.  SQL_ATTR_USE_BOOKMARKS statement attribute is not set in SQL_UB_VARIABLE, and SQL_ATTR_CURSOR_TYPE statement attribute is set to the cursor type for the bookmark which is not supported by the driver.
HYT00	Timeout expired	Before the data source returns the result set, the query timeout period is expired. The timeout can be set via SQL_ATTR_QUERY_TIMEOUT of SQLSetStmtAttr.
HYT01	Connection timeout expired	The connection is expired before the data source responds to the request. The timeout can be set via SQL_ATTR_CONNECTION_TIMEOUT of SQLSetStmtAttr.
IM001	Driver does not support this function	The driver which is related to DescriptorHandle does not support the function.
IM017	Polling is disabled in asynchronous notification mode	Whenever using the notification model, polling can not be used.
Im018	SQLCompleteAsync has not been called to complete the previous asynchronous operation on this handle.	If the previous function call for the handle returns SQL_STILL_EXECUTING and if the notification mode is activated, then SQLCompleteAsync should be called for the handle to do post processing and complete the operation.

## Description

SQLGetTypeInfo returns the same result as the standard result set, and it is sorted to be closely mapped to the data types corresponding to the DATA\_TYPE, ODBC SQL data type. The data types defined by the data source takes precedence over user defined data types. Therefore, the sorting order can be generalized in the ascending order and whose first order is DATA TYPE and then TYPE\_NAME though the order is not always consistent.

For example, if the data source defines an INTEGER and COUNTER data types and COUNTER is automatically increased, and the user defined data type WHOLENUM is defined, then INTEGER, WHOLENUM and C

COUNTER will be returned in order. The result is because WHOLENUM is closely mapped to SQL\_INTEGER and ODBC SQL data type. On the other hand, even though the automatic increasing data types are supported by the data source, they are not mapped closely with ODBC SQL data types.

If DataType argument is valid for ODBC version supported by the driver but the driver does not support it, then an empty result set is returned.

The following column names are changed in ODBC 3.x. The column name change does not affect the compatibility with the previous version because the application is bound by the column number.

ODBC 2.0 column	ODBC 3.x column
PRECISION	COLUMN_SIZE
MONEY	FIXED_PREC_SCALE
AUTO_INCREMENT	AUTO_UNIQUE_VALUE

In ODBC 3.x, the following columns are added to the result set returned by SQLGetTypeInfo.

- SQL\_DATA\_TYPE
- INTERVAL\_PRECISION
- SQL\_DATETIME\_SUB
- NUM\_PREC\_RADIX

The following table lists the columns in the result set. The additional row after column 19 (INTERVAL\_PRECISION) is defined by the driver. The applications should get access to a specific driver column by performing the countdown from the end of the result set instead of specifying an explicit ordinal position.



SQLGetTypeInfo may not return for all data types. For example, the driver may not return the user defined data type. The application can use the valid data types regardless of returning SQLGetTypeInfo. Data types returned by SQLGetTypeInfo are supported by the data source. They are intended to be used in Data Definition Language (DDL). The driver can return the data types used in the result set other than the data types that returned by SQLGetTypeInfo. The driver may use the data types which are not supported by the data source in generating the result set for the catalog function.

Column name	Column number	Data type	Comment
TYPE_NAME (ODBC 2.0)	1	Varchar not NULL	It is data source-dependent data type name. For example, it is "CHAR()", "VARCHAR()", "MONEY", "LONG VARBINARY", or "CHAR ( ) FOR BIT DATA". The application should use this name in CREATE TABLE and ALTER TABLE statements.
DATA_TYPE	2	Smallint not	It is SQL data type. It can be the ODBC SQL data type or driver specific SQL data. For DATETIME or INTERVAL data type, the column returns th

Column name	Column number	Data type	Comment
(ODBC 2.0)		NULL	e simple data type (such as SQL_TYPE_TIME or SQL_INTERVAL_YEAR_TO_MOUNT).
COLUMN_SIZE (ODBC 2.0)	3	Integer	It is the maximum column size for the data type supported by the server. For numeric data, it is the maximum precision. For string data, it returns a length of characters. For datetime data types, it returns a length of represented characters. For interval data, it returns the length of characters in the character representation of the interval literal. NULL is returned for data types whose column size is not applicable.
LITERAL_PREFIX (ODBC 2.0)	4	Varchar	A character or string is used as a prefix. For example, a single quote (') is for a character, 0x, or binary data type. NULL is returned for a data type which can not be used as a prefix.
LITERAL_SUFFIX (ODBC 2.0)	5	Varchar	A character or string is used as the termination character. For example, a single mark (') is for the character data type. NULL is returned for data types that can not be used as a suffix.
CREATE_PARAMS (ODBC 2.0)	6	Varchar	It is a keyword list corresponding to each parameter (separated by commas) which is specified by the application in parentheses when the name which is returned to TYPE_NAME is used. Keywords in the list can be length, precision, or scale. They are listed as the order in which the grammar uses keywords. For example, CREATE_PARAMS for DECIMAL can be "precision, scale". CRATE_PARAMS for VARCHAR can be the same "length". If parameter does not exist for defining data type, NULL is returned (e.g. INTERGER). The driver provides CREATE_PARAMS text in the language of the country/region.
NULLABLE (ODBC 2.0)	7	Smallint not NULL	It is whether the data type accepts NULL. SQL_NO_NULLS does not accept NULL as a data type. SQL_NULLABLE does accept NULL as a data type. SQL_NULLABLE_UNKNOWN do not know whether the column accepts NULL.
CASE_SENSITIVE (ODBC 2.0)	8	Smallint not NULL	It is whether the character data type is case-sensitive in sorting and comparison. It is SQL_TRUE if the data type is a character data type and it is case-sensitive. It is SQL_FALSE if the data type is not a character data type or it is case-insensitive.
SEARCHABLE (ODBC 2.0)	9	Smallint not NULL	It is how the data type is used in a WHERE clause. If a column can not be used in WHERE clause, it is SQL_PRED_NONE. (It is as same as the value of SQL_UNSEARCHABLE in ODBC 2.x.) If a column can be used only with LIKE condition in WHERE clause, it is SQL_PRED_CHAR. (It is as same as the value of SQL_LIKE_ONLY in ODBC 2.x.) If a column can be used with all comparison operators except LIKE condition in WHERE clause, it is SQL_PRED_BASIC. (It is as same as the val



Column name	Column number	Data type	Comment
			ue of SQL_ALL_EXCEPT_LIKE in ODBC 2.x.) If a column can be used with all comparison operators in WHERE clause, it is SQL_SEARCHABLE.
UNSIGNED_ATTRIBUTE (ODBC 2.0)	10	Smallint	It is whether the data type is signed. If a data type is unsigned, it is SQL_TRUE. If a data type is signed, it is SQL_FALSE. If the attribute can not be used in data type or it is not a numeric data type NULL is returned.
FIXED_PRECISION_SCALE (ODBC 2.0)	11	Smallint not NULL	It is whether the data type (specific data source) has a predefined fixed precision and scale. If the data type has a predefined fixed precision and scale, it is SQL_TRUE. If the data type does not have predefined fixed precision and scale, it is SQL_FALSE.
AUTO_INCREMENT_VALUE (ODBC 2.0)	12	Smallint	It is whether data type is automatically increased. If the data type is automatically increased, it is SQL_TRUE. If the data type is not automatically increased, it is SQL_FALSE If the attribute can not be used in data type or it is not a numeric data type, NULL is returned. The application can insert the value in the column having this attribute, but can not typically update the value of the column. When insertion occurs in the automatically increased column, a unique value is inserted in the column. The increment is not defined but is data source-specific. The application should not assume that the auto-increment column starts at a specific point or it is increased by a certain value.
LOCAL_TYPE_NAME (ODBC 2.0)	13	Varchar	It is a localized version of the data type name dependent on the data source. If the localized name is not supported by the data source, NULL is returned. The name is used for display only, like as a dialog box.
MINIMUM_SCALE (ODBC 2.0)	14	Smallint	It is the minimum scale of the data type on the data source. If the data type is a fixed Scale, MINIMUM_SCALE and MAXIMUM_SCALE columns have this value. For example, SQL_TYPE_TIMESTAMP column has the fixed scale for fractional seconds. NULL is returned if scale can not be used.
MAXIMUM_SCALE (ODBC 2.0)	15	Smallint	It is the maximum scale of the data type on the data source. If scale can not be used, NULL is returned. If the maximum scale is not separately defined on the data source, but it is defined as same as the maximum precision, then the column has the same value as COLUMN_SIZE.
SQL_DATA_TYPE (ODBC 3.0)	16	Smallint NOT NULL	It is the value of SQL data type which appears in SQL_DESC_TYPE field of the descriptor. The column is as same as DATA_TYPE column except for INTERVAL and DATETIME data types. SQL_DATA_TYPE field in the result set returns SQL_INTERVAL or SQL_DATETIME for INTERVAL and DATETIME data types, and SQL_DATETIME_SUB field returns the sub-co

Column name	Column number	Data type	Comment
			de for INTERVAL or DATETIME data types.
SQL_DATETIME_SUB (ODBC 3.0)	17	Smallint	If a value of SQL_DATE_TYPE is SQL_DATETIME or SQL_INTERVAL, this column has the sub code of DATETIME/ INTERVAL. For other data types, the field is NULL. For INTERVAL or DATETIME data types, SQL_DATE_TYPE of the result set returns SQL_INTERVAL or SQL_DATETIME, SQL_DATETIME_SUB field returns the sub code for INTERVAL or DATETIME data type.
NUM_PREC_RADIX (ODBC 3.0)	18	Integer	If the data type is an approximate numeric type, the column has the value 2 to indicate that the COLUMN_SIZE specifies the number of bits. For the exact numeric type, the column has the value 10 to indicate that COLUMN_SIZE specifies decimal values. Otherwise, this column is NULL.
INTERVAL_PRECISION (ODBC 3.0)	19	Smallint	For INTERVAL data type, the column has the value of "INTERVAL leading precision". Otherwise, the column has NULL.

Attribute information can be applied to a particular column in the result set or the data type. SQLGetTypeInfo returns information about the attributes related to a data type. SQLColAttribute returns information about the attributes related to a column in the result set.

# SQLMoreResults

## Conformance

Introduced version: ODBC 1.0

Standards compliance: ODBC

## Overview

SQLMoreResults checks that more results are available in the statements including SELECT, UPDATE, INSERT, or DELETE statement, and if so, the processing for the results is initialized.

## Syntax

```
SQLRETURN SQLMoreResults(
    SQLHSTMT    StatementHandle);
```

## Arguments

### StatementHandle

[Input] It is the statement handle.

## Returns

SQL\_SUCCESS, SQL\_SUCCESS\_WITH\_INFO, SQL\_STILL\_EXECUTING, SQL\_NO\_DATA, SQL\_ERROR, SQL\_INVALID\_HANDLE, SQL\_PARAM\_DATA\_AVAILABLE

## Diagnosis

SQLSTATE	Error	Description
01000	General Warning	It is the driver-specific informational message. (The function returns SQL_SUCCESS_WITH_INFO.)
01S02	Option value changed	The value of the statement attribute is changed while the batch is being processed. (The function returns SQL_SUCCESS_WITH_INFO.)
08S01	Communication link failure	Before the function processing is completed, the connection between the driver and the data source is failed.
40001	Serialization failure	The transaction is rolled back due to a resource deadlock of other transactions.

SQLSTATE	Error	Description
40003	Statement completion unknown	The related connection is failed during the function execution, and the status of transaction can not be checked.
HY000	General error	It is an error without any specific SQLSTATE.
HY001	Memory allocation error	It is a memory allocation error.
HY008	Operation canceled	Asynchronous processing for StatementHandle is available and SQLCancel or SQLCancelHandle is called on StatementHandle before the function is called and completed. Then this function is called again on StatementHandle.  SQLCancel or SQLCancelHandle is called on StatementHandle from other thread in the multithreaded application before the function is called and completed.
HY010	Function sequence error	The asynchronously executing function is called for the connection handle related to StatementHandle, but it is still being asynchronously executed when SQLMoreResultsr is called.  The asynchronously executing function is called for the StatementHandle, it is still being asynchronously executed when the function is called.  SQLExecute, SQLExecDirect, SQLBulkOperation or SQLSetPos is called for StatementHandle, and SQL_NEED_DATA is returned. This function is called before data is sent for all data-at-execution parameters or columns.
HY013	Memory management error	The size of buffer used as an argument is smaller than 0, or it can not access the memory.
HY117	Connection is suspended due to unknown transaction state. Only disconnect and read-only functions are allowed.	For more information about the suspended state, refer to <b>SQLEndTran</b> .
HYT01	Connection timeout expired	The connection is expired before the data source responds to the request. The timeout can be set via SQL_ATTR_CONNECTION_TIMEOUT of SQLSetStmtAttr.
IM001	Driver does not support this function	The driver which is related to DescriptorHandle does not support the function.
IM017	Polling is disabled in asynchronous notification mode	Whenever using the notification model, polling can not be used.
Im018	SQLCompleteAsync has not been called to complete the previous asynchronous operation on this handle.	If the previous function call for the handle returns SQL_STILL_EXECUTING and if the notification mode is activated, then SQLCompleteAsync should be called for the handle to do post processing and complete the operation.

## Description

SELECT statement returns the result set. UPDATE, INSERT, and DELETE statements return the number of rows affected.

If one of these statements are batched or an array of parameters are passed or in progress, then multiple result sets or the number of rows can be returned.

The batch is processed, and the application is positioned in the first result set. The application can call SQLBindCol, SQLBulkOperations, SQLFetch, SQLGetData, SQLFetchScroll, SQLSetPos and all the meta data functions as if a single result set exists for the first or subsequent result sets. When SQLMoreResults is executed as the first result set, the application calls SQLMoreResults to move to the next result set. If another result set or its number is available, SQLMoreResults returns SQL\_SUCCESS and initializes the result set or performs the aggregate for the additional operations. If any count row generation statement appears between the result set generation statements, the row generation statement can be sent to SQLMoreResults call. If SQLMoreResults is called for UPDATE, INSERT, or DELETE statement, the application can call SQLRowCount.

If a current result set with un fetched rows exists, SQLMoreResults discards the result set and generates the next result set or aggregates it. If all result sets are processed, SQLMoreResults returns SQL\_NO\_DATA. For some drivers, the output parameter and the return value can not be used until all result sets and row aggregation are processed. In this case, the output parameter and return value can be used after SQLMoreResults returned SQL\_NO\_DATA.

All bindings made for the previous result set still remains valid. If the column structure is different from the result set, then calling SQLFetch or SQLFetchScroll can cause an error or truncation. To prevent it, the application should call SQLBindCol for the explicit rebinding. The application can call SQLFreeStmt with SQL\_UNBIND option to release the binding for all column buffers.

The statement attribute values such as the cursor type, cursor concurrency, key set size, or maximum length can be changed while the application calls SQLMoreResults and performs the batch processing. SQLMoreResults can return SQL\_SUCCESS\_WITH\_INFO and SQLSTATE 01S02 (Option value has changed).

If SQLCloseCursor or SQLFreeStmt is called with an SQL\_CLOSE option, then the number of available rows such as all the result set and batch processing result is discarded. The statement handle returns one of the assigned state and prepared state. When the batch is processed and the statement handle is executed, then SQLCancel is called to cancel the asynchronously executing function. If SQLCancel is executed successfully, all asynchronous status results which are generated by the batch processing, and the number of rows can be discarded. The statement handle returns one of the assigned state and prepared state.

If the batch or procedure of the statement mixes SELECT, UPDATE, INSERT, DELETE statements with other SQL statements, these statements does not affect SQLMoreResults.

If a searched update, insert or delete statement in batch statements does not affect to any row of the data source, `SQLMoreResults` returns `SQL_SUCCESS`. It is different from the case of when `SQLExecDirect`, `SQLExecute`, or `SQLParamData` returns `SQL_NO_DATA`. If the application calls `SQLRowCount` to retrieve the number of rows after `SQLMoreResults` does not affect any row, then `SQLRowCount` may return `SQL_NO_DATA`.

## Availability of the Number of Rows

If the batch processing includes the statement for consecutive multiple row aggregate generation, the row aggregation can be rolled up to a single row. For example, if a batch includes five `INSERT` statements, the particular data source can return the five individual rows. Some other data sources return a single row that represents the sum of the total five individual rows.

If a batch processing includes the combination of the result set generation and row aggregate generation statement, then the number of rows may not be available.

The driver operation for the availability of the number of rows is listed in `SQL_BATCH_ROW_COUNT` information type used via `SQLGetInfo` call. For example, if the batch processing includes two `INSERT` statements and `SELECT` statement followed by the other `SELECT` statement, then the following cases are available.

- The number of rows corresponding to the two `INSERT` statements can not be used. The first call of `SQLMoreResults` is located in the result set of the second `SELECT` statement.
- The number of rows corresponding to the two `INSERT` statements can be individually used. (`SQLGetInfo` does not return `SQL_BRC_ROLLED_UP` bit for `SQL_BATCH_ROW_COUNT` information type.) The first call of `SQLMoreResults` is located in the number of rows of the first `INSERT` statement, and the second call is positioned in the number of rows of the second `INSERT` statement. The third call may be located in result set of the second `SELECT` statement.
- The number of rows corresponding to the two `INSERT` statements is rolled up to a single available row. (Calling `SQLGetInfo` returns `SQL_BRC_ROLLED_UP` bit for `SQL_BATCH_ROW_COUNT` information type.) The first `SQLMoreResults` may be located overlapping with the number of rows, and the second `SQLMoreResults` may be located in the result set of the second `SELECT` statement.

A specific driver makes the number of rows available only for the explicit batch processing.

# SQLNativeSql

It is not supported.

## Conformance

Introduced version: ODBC 1.0

Standards compliance: ODBC

## Overview

SQLNativeSql returns the SQL string modified by the driver. SQLNativeSql does not execute SQL statement.

## Syntax

```
SQLRETURN SQLNativeSql(  
    SQLHDBC      ConnectionHandle,  
    SQLCHAR *    InStatementText,  
    SQLINTEGER   TextLength1,  
    SQLCHAR *    OutStatementText,  
    SQLINTEGER   BufferLength,  
    SQLINTEGER * TextLength2Ptr);
```

# SQLNumParams

## Conformance

Introduced version: ODBC 1.0

Standards compliance: ISO 92

## Overview

SQLNumParams returns the number of parameters in the SQL statement.

## Syntax

```
SQLRETURN SQLNumParams(  
    SQLHSTMT      StatementHandle,  
    SQLSMALLINT * ParameterCountPtr);
```

## Arguments

### StatementHandle

[Input] It is the statement handle.

### ParameterCountPtr

[Output] It is the buffer pointer to which the number of parameters of the statement is to be returned.

## Returns

SQL\_SUCCESS, SQL\_SUCCESS\_WITH\_INFO, SQL\_STILL\_EXECUTING, SQL\_ERROR, SQL\_INVALID\_HANDLE

## Diagnosis

SQLSTATE	Error	Description
01000	General warning	It is the driver-specific informational message. (The function returns SQL_SUCCESS_WITH_INFO.)
08S01	Communication link failure	Before the function processing is completed, the connection between the driver and the data source is failed.
HY000	General error	It is an error without any specific SQLSTATE.
HY001	Memory allocation error	It is a memory allocation error.



SQLSTATE	Error	Description
HY008	Operation canceled	<p>Asynchronous processing for StatementHandle is available and SQLCancel or SQLCancelHandle is called on StatementHandle before the function is called and completed. Then this function is called again on StatementHandle.</p> <p>SQLCancel or SQLCancelHandle is called on StatementHandle from other thread in the multithreaded application before the function is called and completed.</p>
HY010	Function sequence error	<p>The function is called in StatementHandle before calling SQLPrepare or SQLExecDirect.</p> <p>The asynchronously executing function is called for the connection handle related to StatementHandle, but it is still being asynchronously executed when SQLNumParams is called.</p> <p>The asynchronously executing function is called for the StatementHandle, it is still being asynchronously executed when the function is called.</p> <p>SQLExecute, SQLExecDirect, SQLBulkOperation or SQLSetPos is called for StatementHandle, and SQL_NEED_DATA is returned. This function is called before data is sent for all data-at-execution parameters or columns.</p>
HY013	Memory management error	The internal memory can not be accessed or the available memory size is small.
HY117	Connection is suspended due to unknown transaction state. Only disconnect and read-only functions are allowed.	For more information about the suspended state, refer to <b>SQLEndTran</b> .
HYT01	Connection timeout expired	The connection is expired before the data source responds to the request. The timeout can be set via SQL_ATTR_CONNECTION_TIMEOUT of SQLSetStmtAttr.
IM001	Driver does not support this function	The driver which is related to StatementHandle does not support the function.
IM017	Polling is disabled in asynchronous notification mode	Whenever using the notification model, polling can not be used.
IM018	SQLCompleteAsync has not been called to complete the previous asynchronous operation on this handle.	If the previous function call for the handle returns SQL_STILL_EXECUTING and if the notification mode is activated, then SQLCompleteAsync should be called for the handle to do post processing and complete the operation.

## Description

SQLNumParams can be called only after SQLPrepare is called.

If the statement related to StatementHandle does not have any parameter, then SQLNumParams sets \*ParameterCountPtr to 0.

The number of parameters which are returned by SQLNumParams is as same as the value of SQL\_DESC\_COUNT field of IPD.

# SQLNumResultCols

## Conformance

Introduced version: ODBC 1.0

Standards compliance: ISO 92

## Overview

SQLNumResultCols returns the number of columns in the result set.

## Syntax

```
SQLRETURN SQLNumResultCols(
    SQLHSTMT      StatementHandle,
    SQLSMALLINT * ColumnCountPtr);
```

## Arguments

### StatementHandle

[Input] It is the statement handle.

### ColumnCountPtr

[Output] It is the buffer pointer to which the number of columns in the result set is to be returned. The number does not include the bookmark column.

## Returns

SQL\_SUCCESS, SQL\_SUCCESS\_WITH\_INFO, SQL\_STILL\_EXECUTING, SQL\_ERROR, SQL\_INVALID\_HANDLE

## Diagnosis

SQLSTATE	Error	Description
01000	General warning	It is the driver-specific informational message. (The function returns SQL_SUCCESS_WITH_INFO.)
08S01	Communication link failure	Before the function processing is completed, the connection between the driver and the data source is failed.
HY000	General error	It is an error without any specific SQLSTATE.
	Memory allocation error	

SQLSTATE	Error	Description
HY001	or	It is a memory allocation error.
HY008	Operation canceled	Asynchronous processing for StatementHandle is available and SQLCancel or SQLCancelHandle is called on StatementHandle before the function is called and completed. Then this function is called again on StatementHandle.  SQLCancel or SQLCancelHandle is called on StatementHandle from other thread in the multithreaded application before the function is called and completed.
HY010	Function sequence error	The function is called in StatementHandle, before SQLPrepare or SQLExecuteDirect is called.  The asynchronously executing function is called for the connection handle related to StatementHandle, but it is still being asynchronously executed when SQLNumResultsCols is called.  The asynchronously executing function is called for the StatementHandle, it is still being asynchronously executed when the function is called.  SQLExecute, SQLExecuteDirect, SQLBulkOperation or SQLSetPos is called for StatementHandle, and SQL_NEED_DATA is returned. This function is called before data is sent for all data-at-execution parameters or columns.
HY013	Memory management error	The internal memory can not be accessed or the available memory size is small.
HY117	Connection is suspended due to unknown transaction state. Only disconnect and read-only functions are allowed.	For more information about the suspended state, refer to <b>SQLEndTran</b> .
HYT01	Connection timeout expired	The connection is expired before the data source responds to the request. The timeout can be set via SQL_ATTR_CONNECTION_TIMEOUT of SQLSetStmtAttr.
IM001	Driver does not support this function	The driver which is related to DescriptorHandle does not support the function.
IM017	Polling is disabled in a synchronous notification mode	Whenever using the notification model, polling can not be used.
IM018	SQLCompleteAsync has not been called to complete the previous asynchronous operation	If the previous function call for the handle returns SQL_STILL_EXECUTING and if the notification mode is activated, then SQLCompleteAsync should be called for the handle to do post processing and complete the operation.

SQLSTATE	Error	Description
	on on this handle.	

## Description

SQLNumResultCols is successfully called only when the statement is in the prepared, executed, positioned state.

If the statement related to StatementHandle does not return the column, then SQLNumResultCols sets \*ColumnCountPtr to 0.

The number of rows returned by SQLNumResultCols is as same as the value of SQL\_DESC\_COUNT field of IRD.

# SQLParamData

## Conformance

Introduced version: ODBC 1.0

Standards compliance: ISO 92

## Overview

SQLParamData is used together with SQLPutData to provide the parameters at the statement execution time.

## Syntax

```
SQLRETURN SQLParamData(
    SQLHSTMT      StatementHandle,
    SQLPOINTER *  ValuePtrPtr);
```

## Returns

SQL\_SUCCESS, SQL\_SUCCESS\_WITH\_INFO, SQL\_NEED\_DATA, SQL\_NO\_DATA, SQL\_STILL\_EXECUTING, SQL\_ERROR, SQL\_INVALID\_HANDLE, SQL\_PARAM\_DATA\_AVAILABLE

## Diagnosis

SQLSTATE	Error	Description
01000	General warning	It is the driver-specific informational message. (The function returns SQL_SUCCESS_WITH_INFO.)
08S01	Communication link failure	Before the function processing is completed, the connection between the driver and the data source is failed.
HY000	General error	It is an error without any specific SQLSTATE.
HY001	Memory allocation error	It is a memory allocation error.
HY010	Function sequence error	The previous function is not SQLExecute nor is SQLExecDirect which returns SQL_NEED_DATA.  The previous function is SQLParamData.
HY013	Memory management error	The internal memory can not be accessed or the available memory size is small.

SQLSTATE	Error	Description
HYT01	Connection time out expired	The connection is expired before the data source responds to the request. The timeout can be set via SQL_ATTR_CONNECTION_TIMEOUT of SQLSetStmtAttr.

If SQLParamData is called to transfer the data for a parameter, then it can return SQLSTATE of SQLExecute or SQLExecDirect.

## Description

The driver returns SQL\_NEED\_DATA when the application calls SQLExecute or SQLExecDirect which requires data-at-execution. The application calls SQLParamData to determine the data to be transferred. If the driver needs the parameter data, then the value of \*ValuePtr entered by the application is returned. The application can use the value to determine the parameter data requested by the driver.

The application calls SQLPutData as many times as necessary to transfer data-at-execution parameter. The application calls SQLParamData again after all parameter data is transferred. When SQLParamData returns SQL\_NEED\_DATA again, the application should call SQLPutData to transfer the other parameter data again. If all parameter data are transferred, then SQLParamData returns SQL\_SUCCESS or SQL\_SUCCESS\_WITH\_INFO and the value of \*ValuePtr is not defined and the SQL statement can be executed.

# SQLParamOptions

## Conformance

Introduced version: ODBC 1.0

Standards compliance: It is not available.

## Overview

SQLParamOptions function in ODBC 2.0 is replace with `SQLSetStmtAttr` in ODBC 3.x.



# SQLPrepare

## Conformance

Introduced version: ODBC 1.0

Standards compliance: ISO 92

## Overview

SQLPrepare prepares the SQL string for execution.

## Syntax

```
SQLRETURN SQLPrepare(
    SQLHSTMT      StatementHandle,
    SQLCHAR *     StatementText,
    SQLINTEGER    TextLength);
```

## Arguments

### StatementHandle

[Input] It is the statement handle.

### StatementText

[Input] It is the SQL text string.

### TextLength

[Input] It is the length of \*StatementText in characters.

## Returns

SQL\_SUCCESS, SQL\_SUCCESS\_WITH\_INFO, SQL\_STILL\_EXECUTING, SQL\_ERROR, SQL\_INVALID\_HANDLE

## Diagnosis

SQLSTATE	Error	Description
01000	General warning	It is the driver-specific informational message. (The function returns SQL_SUCCESS_WITH_INFO.)
		It is temporarily replaced with the similar value because the specified statem

SQLSTATE	Error	Description
01S02	Option value changed	<p>ent attribute is invalid due to implementation working condition. (SQLGetStmtAttr can be called to see which value is temporarily changed.) The replaced value is valid for StatementHandle until the cursor is closed, and it is changed to the previous value when the cursor is closed.</p> <p>The updatable statement attributes are as follows. SQL_ATTR_CONCURRENCY, SQL_ATTR_CURSOR_TYPE, SQL_ATTR_KEYSET_SIZE, SQL_ATTR_MAX_LENGTH, SQL_ATTR_MAX_ROWS, SQL_ATTR_QUERY_TIMEOUT, SQL_ATTR_SIMULATE_CURSOR. (The function returns SQL_SUCCESS_WITH_INFO.)</p>
21S01	Insert value list does not match column list	INSERT statement is in *StatementText, and the number of values to be inserted do not match the derived table.
21S02	Degree of derived table does not match column list	CREATE view statement is in *StatementText, and the number of specified names are not as same as the derived table defined by the query specifications.
22018	Invalid character value for cast specification	The SQL statement which includes a string or parameter is in *StatementText, and the value is not compatible with the data type of related table column.
22019	Invalid escape character	StatementText argument includes LIKE predicate such as ESCAPE in WHERE clause, and a control character length of ESCAPE is not 1.
22025	Invalid escape sequence	StatementText argument includes "LIKE pattern value ESCAPE escape character" in WHERE clause, and the pattern value control character is neither "%" nor is "-".
24000	Invalid cursor state	The cursor is open in StatementHandle, and SQLFetch or SQLFetchScroll is called.
34000	Invalid cursor name	*StatementText includes the positioned DELETE or positioned UPDATE, and the cursor referenced by the prepared statement is not open.
3D000	Invalid catalog name	The catalog name specified in StatementText is not valid.
3F000	Invalid schema name	The schema name specified in StatementText is not valid.
42000	Syntax error or access violation	<p>*StatementText includes an SQL statement which is not preparable or it includes a syntax error.</p> <p>*StatementText includes a user without required privileges in a statement.</p>
42S01	Base table or view already exists	*StatementText includes CREATE TABLE or CREATE VIEW statement, and the specified table name or the view name already exists.
		<p>*StatementText includes DROP TABLE or DROP VIEW statement, and the specified table name or view name does not exist.</p> <p>*StatementText includes ALTER TABLE statement, and the specified table name does not exist.</p>

SQLSTATE	Error	Description
42S02	Base table or view not found	<p>*StatementText includes CREATE VIEW statement, and the table name or view name defined does not exist in the query specifications.</p> <p>*StatementText includes CREATE INDEX statement, and the specified table name does not exist.</p> <p>*StatementText includes GRANT or REVOKE statement, and the specified table name or view name does not exist.</p> <p>*StatementText includes SELECT statement, and the table or view name specified does not exist.</p> <p>*StatementText includes DELETE, INSERT or UPDATE statement, and the specified table name does not exist.</p> <p>*StatementText includes CREATE TABLE statement, and the table (refers to other tables) whose constraint is specified does not exist.</p>
42S11	Index already exists	CREATE INDEX statement is in *StatementText, and the specified INDEX name already exists.
42S12	Index not found	DROP INDEX statement is in *StatementText, and the specified INDEX name does not exist.
42S21	Column already exist	ALTER TABLE statement is in *StatementText, and the specified column in ADD clause is not unique or it identifies the existing column in the base table.
42S22	Column not found	<p>CREATE INDEX statement is in *StatementText, and one or more column names do not exist in the specified column list.</p> <p>GRANT or REVOKE statement is in *StatementText, and the specified column name does not exist.</p> <p>SELECT, DELETE or UPDATE statement is in *StatementText, and the specified column name does not exist.</p> <p>CREATE TABLE statement is in *StatementText, the column whose constraint is specified does not exist.</p>
HY000	General error	It is an error without any specific SQLSTATE.
HY001	Memory allocation error	It is a memory allocation error.
HY008	Operation cancelled	<p>Asynchronous processing for StatementHandle is available and SQLCancel or SQLCancelHandle is called on StatementHandle before the function is called and completed. Then, this function is called again on StatementHandle.</p> <p>SQLCancel or SQLCancelHandle is called on StatementHandle from another</p>

SQLSTATE	Error	Description
		thread in the multithreaded application before the function is called and completed.
HY009	Invalid use of null pointer	StatementText is a NULL pointer.
HY010	Function sequence error	<p>The function is called in StatementHandle before calling SQLPrepare or SQLExecDirect.</p> <p>The asynchronously executing function is called for the connection handle related to StatementHandle, but it is still being asynchronously executed when SQLPrepare is called.</p> <p>The asynchronously executing function is called for the StatementHandle, it is still being asynchronously executed when the function is called.</p> <p>SQLExecute, SQLExecDirect, SQLBulkOperation or SQLSetPos is called for StatementHandle, and SQL_NEED_DATA is returned. This function is called before data is sent for all data-at-execution parameters or columns.</p>
HY013	Memory management error	The internal memory can not be accessed or the available memory size is small.
HY090	Invalid string or buffer length	TextLength is equal to or smaller than 0, or it is not as same as SQL_NTS.
HY117	Connection is suspended due to unknown transaction state. Only disconnect and read-only functions are allowed.	For more information about the suspended state, refer to <b>SQLEndTran</b> .
HYC00	Optional feature not implemented	The concurrency set is not valid for the defined cursor type. SQL_ATTR_USE_BOOKMARKS statement attribute is set to SQL_UB_VARIABLE, and SQL_ATTR_CURSOR_TYPE statement attribute is set to the cursor type for the bookmark that is not supported by the driver.
HYT00	Timeout expired	The query timeout is expired before getting the result set from the data source. The timeout can be set via SQL_ATTR_QUERY_TIMEOUT of SQLSetStmtAttr.
HYT01	Connection timeout expired	The connection is expired before the data source responds to the request. The timeout can be set via SQL_ATTR_CONNECTION_TIMEOUT of SQLSetStmtAttr
IM001	Driver does not support this function	The driver which is related to StatementHandle does not support the function.
	Polling is disabled in asynchronous	

SQLSTATE	Error	Description
IM017	s notification mode	Whenever using the notification model, polling can not be used.
IM018	SQLCompleteAsync has not been called to complete the previous asynchronous operation on this handle.	If the previous function call for the handle returns SQL_STILL_EXECUTING and if the notification mode is activated, then SQLCompleteAsync should be called for the handle to do post processing and complete the operation.

## Description

The application calls SQLPrepare to send the SQL statements to the data source for preparation. The application can include one or more parameter markers in the SQL statement. The application describes the question mark (?) at an appropriate position in the SQL string to include the parameter marker.



If the application uses SQLPrepare to prepare, or uses SQLExecute to submit COMMIT or ROLLBACK statement, then it is impossible to interoperate between DBMS products.

The driver can update the statement to use the SQL types used by the data source, and pass it to the data source for the preparation. Especially, the driver updates the extended bit string which is used to define the SQL statement for a particular function. In the driver, the statement handle is similar to the statement identifier in the embedded SQL code. If the data source supports statement identifiers, the driver can send a statement identifier and parameter values to the data source.

After the statement is prepared, the application uses the statement handle to refer to the statement in the later function calls. The prepared statement related to the statement handle can be executed again with calling SQLExecute until the application releases the statement by calling SQLFreeStmt with SQL\_DROP option or the statement handle uses one of SQLPrepare, SQLExecDirect or catalog function(SQLColumns, SQLTables, etc.). Once the application prepares the statement, information about the format of the result set may be requested. For some implementations, after SQLPrepare, calling of SQLDescribeCol or SQLDescribeParam is not as effective as calling after SQLExecute or SQLExecDirect.

The driver can not return a syntax error or access violation when the application calls SQLPrepare. The driver can handle all syntax errors and access violations, or it can handle only syntax errors, or it can not handle all syntax errors nor does return access violations. The application should be able to handle these conditions when calling a subsequent related functions (the subsequent functions such as SQLNumResultCols, SQLDescribeCol, SQLColAttribute, SQLExecute).

According to the features of the driver and data source, parameter information (such as the data type) can be checked when the statement is prepared (when all parameters are bound) or is executed (when all parameters are not bound).

The application should release the binding of all parameters previously applied to the SQL statement before preparing the new SQL statement in the same statement. It can prevent an error whose previous parameter information is applied to the new statement.



Committing a transaction by explicitly calling `SQLEndTran` or by working in autocommit mode, can cause the data source to delete the access plans for all statements on a connection. For more information, refer to `SQL_CURSOR_COMMIT_BEHAVIOR` and `SQL_CURSOR_ROLLBACK_BEHAVIOR` information types in `SQLGetInfo`.

# SQLPrimaryKeys

## Conformance

Introduced version: ODBC 1.0

Standards compliance: ODBC

## Overview

SQLPrimaryKeys returns the column name consists of the primary key of a table. The driver returns information as a result set. The function does not support returning the primary key from the multiple tables in a single call.

## Syntax

```
SQLRETURN SQLPrimaryKeys(  
    SQLHSTMT      StatementHandle,  
    SQLCHAR *     CatalogName,  
    SQLSMALLINT   NameLength1,  
    SQLCHAR *     SchemaName,  
    SQLSMALLINT   NameLength2,  
    SQLCHAR *     TableName,  
    SQLSMALLINT   NameLength3);
```

## Arguments

### StatementHandle

[Input] It is the statement handle.

### CatalogName

[Input] It is the catalog name. If the driver supports the catalog only for a few tables, an empty string ("") indicates the table with no catalog. CatalogName can not include the string search pattern.

If SQL\_ATTR\_METADATA\_ID is set to SQL\_TRUE, CatalogName is treated as an identifier, and it is not case sensitive. If it is set to SQL\_FALSE, CatalogName is treated as an ordinary argument literal, and it is case sensitive.

### NameLength1

[Input] It is the length of \*CatalogName in characters.

**SchemaName**

[Input] It is the schema name. If the driver supports the schema only for a few tables, an empty string ("") indicates the table with no schema. SchemaName can not include the string search pattern.

If SQL\_ATTR\_METADATA\_ID is set to SQL\_TRUE, SchemaName is treated as an identifier, and it is not case sensitive. If it is set to SQL\_FALSE, SchemaName is treated as a pattern value string, and it is not case sensitive.

**NameLength2**

[Input] It is the length of \*SchemaName in characters.

**TableName**

[Input] It is the table name. The argument can not be a null pointer. TableName can not include the string search pattern.

If SQL\_ATTR\_METADATA\_ID is set to SQL\_TRUE, TableName is treated as an identifier, and it is not case sensitive. If it is set to SQL\_FALSE, TableName is treated as an ordinary literal, and it is not case sensitive.

**NameLength3**

[Input] It is the length of \*TableName in characters.

**Returns**

SQL\_SUCCESS, SQL\_SUCCESS\_WITH\_INFO, SQL\_STILL\_EXECUTING, SQL\_ERROR, SQL\_INVALID\_HANDLE

**Diagnosis**

SQLSTATE	Error	Description
01000	General warning	It is the driver-specific informational message. (The function returns SQL_SUCCESS_WITH_INFO.)
08S01	Communication link failure	Before the function processing is completed, the connection between the driver and the data source is failed.
24000	Invalid cursor state	SQLFetch or SQLFetchScroll is called, and the cursor is open. SQLFetch or SQLFetchScroll is not called, but the cursor is open.
40001	Serialization failure	The transaction is rolled back due to a resource deadlock of other transactions.
40003	Statement completion unknown	The related connection fails during the function execution and the status of the transaction is not able to be checked.
HY000	General error	It is an error without any specific SQLSTATE.
HY001	Memory allocation error	It is a memory allocation error.
		Asynchronous processing for StatementHandle is available and SQLCancel or SQLCancelHandle is called on StatementHandle before the function is called a



SQLSTATE	Error	Description
HY008	Operation canceled	<p>nd completed. Then this function is called again on StatementHandle.</p> <p>SQLCancel or SQLCancelHandle is called on StatementHandle from another thread in the multithreaded application before this function is called and completed.</p>
HY009	Invalid use of null pointer	<p>TableName argument is a null pointer.</p> <p>SQL_ATTR_METADATA_ID statement attribute is set to SQL_TRUE, and CatalogName argument is a null pointer.</p> <p>SQLGetInfo with the SQL_CATALOG_NAME information type returns that catalog names are supported.</p> <p>SQL_ATTR_METADATA_ID statement attribute is set to SQL_TRUE, and SchemaName argument is a null pointer.</p>
HY010	Function sequence error	<p>The asynchronously executing function is called for the connection handle related to StatementHandle, and this function is still being executed when SQLPrimaryKeys is called.</p> <p>SQLExecute, SQLExecDirect, or SQLMoreResults is called for StatementHandle, and SQL_PARAM_DATA_AVAILABLE is returned. This function is called before the data is checked for all connected parameters.</p> <p>The asynchronously executing function is called for StatementHandle, and is still being executed when this function is called.</p> <p>SQLExecute, SQLExecDirect, SQLBulkOperation or SQLSetPos is called for StatementHandle, and SQL_NEED_DATA is returned. This function is called before data is sent for all data-at-execution parameters or columns.</p>
HY013	Memory management error	The internal memory can not be accessed or the available memory size is small.
HY090	Invalid string or buffer length	<p>A name length argument value is smaller than 0 but it is not as same as SQL_NTS. The name argument is not a null pointer.</p> <p>A name length argument value is bigger than the maximum length corresponding to the name.</p>
HY117	Connection is suspended due to unknown transaction state. Only disconnect and read-only functions are allowed.	For more information about the suspended state, refer to <a href="#">SQLEndTran</a> .
		The catalog is specified, but the driver or the data source does not support the catalog.

SQLSTATE	Error	Description
HYC00	Optional feature not implemented	<p>The schema is specified, but the driver or the data source does not support the schema.</p> <p>The combination of current setting of SQL_ATTR_CONCURRENCY and SQL_ATTR_CURSOR_TYPE statement attributes is not supported by the driver or data source.</p> <p>SQL_ATTR_USE_BOOKMARKS statement attribute is set to SQL_UB_VARIABLE, and SQL_ATTR_CURSOR_TYPE statement attribute is set to the cursor type for the bookmark that is not supported by the driver.</p>
HYT00	Timeout expired	The query timeout is expired before getting the result set from the data source. The timeout can be set via SQL_ATTR_QUERY_TIMEOUT of SQLSetStmtAttr.
HYT01	Connection timeout expired	The connection is expired before the data source responds to the request. The timeout can be set via SQL_ATTR_CONNECTION_TIMEOUT of SQLSetStmtAttr.
IM001	Driver does not support this function	The driver which is related to StatementHandle does not support the function.
IM017	Polling is disabled in asynchronous notification mode	Whenever using the notification model, polling can not be used.
IM018	SQLCompleteAsync has not been called to complete the previous asynchronous operation on this handle.	If the previous function call for the handle returns SQL_STILL_EXECUTING and if the notification mode is activated, then SQLCompleteAsync should be called for the handle to do post processing and complete the operation.

## Description

SQLPrimaryKeys returns the result as the standard result set sorted by TABLE\_CAT, TABLE\_SCHEM, TABLE\_NAME, and KEY\_SEQ. For more information about how to use this information, refer to **Using Catalog Data**.

The names in the following columns are changed in ODBC 3.x. The column name change does not affect compatibility with the previous version because the application binds by the column number.

ODBC 2.0 column	ODBC 3.x column
TABLE_QUALIFIER	TABLE_CAT
TABLE_OWNER	TABLE_SCHEM

SQLGetInfo is called together with SQL\_MAX\_CATALOG\_NAME\_LEN, SQL\_MAX\_SCHEMA\_NAME\_LEN,

SQL\_MAX\_TABLE\_NAME\_LEN, and SQL\_MAX\_COLUMN\_NAME\_LEN options to determine the actual column length of TABLE\_CAT, TABLE\_SCHEM, TABLE\_NAME, and COLUMN\_NAME.



For more information about general use, arguments, and the returned data of the ODBC catalog functions, refer to **Catalog Function**.

The following table is a column list in the result set. An additional column after the column 6 can be defined by the driver. The application should access the related column by counting down from the end in the result set rather than by explicitly specifying the position. For more information, refer to **Data Returning of Catalog Function**.

Column name	Column number	Data type	Description
TABLE_CAT (ODBC 1.0)	1	Varchar	It is the primary key table catalog name. If it can not be used in the data source, it is NULL. If the driver supports the catalog only for some tables, such as when the drive retrieves the data from another DBMS, it returns an empty string ("") for the table which does not have a catalog.
TABLE_SCHEM (ODBC 1.0)	2	Varchar	It is the primary key table schema name. If it can not be used in the data source, it is NULL. If the driver supports the schema only for some table, such as when the drive retrieves the data from another DBMS, it returns an empty string ("") for the table which does not have a schema.
TABLE_NAME (ODBC 1.0)	3	Varchar not NULL	It is the primary key table name.
COLUMN_NAME (ODBC 1.0)	4	Varchar not NULL	It is the primary key column name. The driver returns an empty string for a column which does not have a name.
KEY_SEQ (ODBC 1.0)	5	Smallint not NULL	It is the column sequence number of the key (starting from 1).
PK_NAME (ODBC 2.0)	6	Varchar	It is the primary key name. If it can not be applied to the data source, it is NULL.

# SQLProcedureColumns

## Conformance

Introduced version: ODBC 1.0

Standards compliance: ODBC

## Overview

SQLProcedureColumns returns the list of input output parameters and the columns which configure the result set of the specified procedure. The driver returns information as the result set for the specified statement.

## Syntax

```
SQLRETURN SQLProcedureColumns(  
    SQLHSTMT      StatementHandle,  
    SQLCHAR *     CatalogName,  
    SQLSMALLINT   NameLength1,  
    SQLCHAR *     SchemaName,  
    SQLSMALLINT   NameLength2,  
    SQLCHAR *     ProcName,  
    SQLSMALLINT   NameLength3,  
    SQLCHAR *     ColumnName,  
    SQLSMALLINT   NameLength4);
```

## Arguments

### StatementHandle

[Input] It is the statement handle.

### CatalogName

[Input] It is the name of the procedure catalog. If the driver does not support the catalog, it returns an empty string ("") and the procedure does not include catalog. CatalogName can not include the string search pattern.

If SQL\_ATTR\_METADATA\_ID is set to SQL\_TRUE, CatalogName is treated as an identifier, and it is not case sensitive. If it is set to SQL\_FALSE, CatalogName is treated as an ordinary argument literal, and it is case sensitive. For more information, refer to Arguments of Catalog Function.

**NameLength1**

[Input] It is the length of \*CatalogName in characters.

**SchemaName**

[Input] It is the name of procedure schema. It is the string search pattern for the schema name. If the driver does not support the schema, it returns an empty string ("") and the procedure does not include the schema. SchemaName can not include the string search pattern.

If SQL\_ATTR\_METADATA\_ID is set to SQL\_TRUE, SchemaName is treated as an identifier, and it is not case sensitive. If it is set to SQL\_FALSE, SchemaName is treated as a pattern value string argument, and it is case sensitive.

**NameLength2**

[Input] It is the length of \*SchemaName in characters.

**ProcName**

[Input] It is the procedure name. This argument can not be a null pointer. ProcName can not include the string search pattern.

If SQL\_ATTR\_METADATA\_ID is set to SQL\_TRUE, ProcName is treated as an identifier, and it is not case sensitive. If it is set to SQL\_FALSE, ProcName is treated as an ordinary literal, and it is not case sensitive.

**NameLength3**

[Input] It is the length of \*ProcName in characters.

**ColumnName**

[Input] It is the column name. This argument can not be a null pointer. ColumnName can not include the string search pattern.

If SQL\_ATTR\_METADATA\_ID is set to SQL\_TRUE, ColumnName is treated as an identifier, and it is not case sensitive. If it is set to SQL\_FALSE, ColumnName is treated as an ordinary literal, and it is not case sensitive.

**NameLength4**

[Input] It is the length of \*ColumnName in characters.

**Returns**

SQL\_SUCCESS, SQL\_SUCCESS\_WITH\_INFO, SQL\_STILL\_EXECUTING, SQL\_ERROR, SQL\_INVALID\_HANDLE

**Diagnosis**

SQLSTATE	Error	Description
01000	General warning	It is the driver-specific informational message. (The function returns SQL_SUCCESS_WITH_INFO.)

SQLSTATE	Error	Description
08S01	Communication link failure	Before the function processing is completed, the connection between the driver and the data source is failed.
24000	Invalid cursor state	<p>The cursor is open in StatementHandle, and SQLFetch or SQLFetchScroll is called.</p> <p>If SQLFetch or SQLFetchScroll returns SQL_NO_DATA, the driver returns this error. If SQLFetch or SQLFetchScroll does not return SQL_NO_DATA, the driver manager returns this error.</p> <p>The result set is open in StatementHandle, but SQLFetch or SQLFetchScroll is not called.</p>
40001	Serialization failure	The transaction is rolled back due to a resource deadlock of other transactions.
40003	Statement completion unknown	The related connection fails during the function execution and the status of the transaction is not able to be checked.
HY000	General error	It is an error without any specific SQLSTATE.
HY001	Memory allocation error	It is a memory allocation error.
HY009	Invalid use of null pointer	<p>TableName argument is a null pointer.</p> <p>SQL_ATTR_METADATA_ID statement attribute is set to SQL_TRUE, and CatalogName argument is a null pointer.</p> <p>SQLGetInfo with the SQL_CATALOG_NAME information type returns that catalog names are supported.</p> <p>SQL_ATTR_METADATA_ID statement attribute is set to SQL_TRUE, and SchemaName, ProcName or ColumnName argument is a null pointer.</p>
HY010	Function sequence error	<p>The asynchronously executing function is called for the connection handle related to StatementHandle, and this function is still executing when SQLProcedureColumns is called.</p> <p>SQLExecute, SQLExecDirect, or SQLMoreResults is called for StatementHandle, and SQL_PARAM_DATA_AVAILABLE is returned. This function is called before the data is checked for all connected parameters.</p> <p>SQLExecute, SQLExecDirect, SQLBulkOperation or SQLSetPos is called for StatementHandle, and SQL_NEED_DATA is returned. This function is called before data is sent for all data-at-execution parameters or columns.</p> <p>The asynchronously executing function is called for StatementHandle, and is still being executed when this function is called.</p>
HY090	Invalid string or buffer	A name length argument value is smaller than 0 but it is not as same as SQL_NTS.

SQLSTATE	Error	Description
	r length	A name length argument value is bigger than the maximum length corresponding to the name.
HY117	Connection is suspended due to unknown transaction state. Only disconnect and read-only functions are allowed.	For more information about the suspended state, refer to <b>SQLEndTran</b> .
HYC00	Optional feature not implemented	<p>The catalog is specified, but the driver or the data source does not support the catalog.</p> <p>The schema is specified, but the driver or the data source does not support the schema.</p> <p>The combination of current setting of <b>SQL_ATTR_CONCURRENCY</b> and <b>SQL_ATTR_CURSOR_TYPE</b> statement attributes is not supported by the driver or data source.</p> <p><b>SQL_ATTR_USE_BOOKMARKS</b> statement attribute is set to <b>SQL_UB_VARIABLE</b>, and <b>SQL_ATTR_CURSOR_TYPE</b> statement attribute is set to the cursor type for the bookmark that is not supported by the driver.</p>
HYT00	Timeout expired	The query timeout is expired before getting the result set from the data source. The timeout can be set via <b>SQL_ATTR_QUERY_TIMEOUT</b> of <b>SQLSetStmtAttr</b> .
HYT01	Connection timeout expired	The connection is expired before the data source responds to the request. The timeout can be set via <b>SQL_ATTR_CONNECTION_TIMEOUT</b> of <b>SQLSetStmtAttr</b> .
IM001	Driver does not support this function	The driver which is related to <b>StatementHandle</b> does not support the function.
IM017	Polling is disabled in asynchronous notification mode	Whenever using the notification model, polling can not be used.
IM018	<b>SQLCompleteAsync</b> has not been called to complete the previous asynchronous operation on this handle.	If the previous function call for the handle returns <b>SQL_STILL_EXECUTING</b> and if the notification mode is activated, then <b>SQLCompleteAsync</b> should be called for the handle to do post processing and complete the operation.

## Description

SQLProcedureColumns returns the list of input output parameters and the columns which configure the result set of the specified procedure. The driver returns information as the result set for the specified statement.

SQLProcedureColumns returns the results as a standard result set, sorted in an order of PROCEDURE\_CAT, PROCEDURE\_SCHEM, PROCEDURE\_NAME, COLUMN TYPE. Column names are returned in an order of each parameter name (in call order) and the name of each column in the result set returned by the procedure.

SQLGetInfo is called together with SQL\_MAX\_CATALOG\_NAME\_LEN, SQL\_MAX\_SCHEMA\_NAME, SQL\_MAX\_PROCEDURE\_NAME\_LEN options in an application to determine the actual column length of PROCEDURE\_CAT, PROCEDURE\_SCHEM, PROCEDURE\_NAME, COLUMN\_NAME.

The names in the following columns are changed in ODBC 3.x. The column name change does not affect compatibility with the previous version because the application binds by the column number.

ODBC 2.0 column	ODBC 3.x column
PROCEDURE_QUALIFIER	PROCEDURE_CAT
PROCEDURE_OWNER	PROCEDURE_SCHEM
PRECISION	COLUMN_SIZE
LENGTH	BUFFER_LENGTH
SACLE	DECIMAL_DIGITS
RADIX	NUM_PREC_RADIX

In ODBC 3.x, the following columns are added to the result set returned by SQLProcedureColumns.

- COLUMN\_DEF
- DATETIME\_CODE
- CHAR\_OCTET\_LENGTH
- ORDINAL\_POSITION
- IS\_NULLABLE

The following table lists the columns in the result set. The additional row after column 19 (IS\_NULLABLE) is defined by the driver. The applications should get access to a specific driver column by performing the countdown from the end of the result set instead of specifying an explicit ordinal position.

Column name	Column number	Data type	Description
PROCEDURE_CAT (ODBC)	1	Varchar	It is the procedure catalog name. If it can not be used in the data source, it is NULL. If the driver supports the catalog only for some tables, suc



Column name	Column number	Data type	Description
C 2.0)			has when the driver retrieves the data from another DBMS, it returns an empty string ("") for the table which does not have a catalog.
PROCEDURE_SCHEM (ODBC 2.0)	2	Varchar	It is the procedure schema name. If it can not be used in the data source, it is NULL. If the driver supports the schema only for some table, such as when the driver retrieves the data from another DBMS, it returns an empty string ("") for the table which does not have a schema.
PROCEDURE_NAME (ODBC 2.0)	3	Varchar not NULL	It is the procedure name. If the procedure does not have a name, then it returns an empty string.
COLUMN_NAME (ODBC 2.0)	4	Varchar not NULL	It is the procedure column name. If the procedure does not have a name, then the driver returns an empty string.
COLUMN_TYPE (ODBC 2.0)	5	Smallint not NULL	It defines the procedure types. <ul style="list-style-type: none"> <li>SQL_PARAM_TYPE_UNKNOWN: The procedure column type is not known. (ODBC 1.0)</li> <li>SQL_PARAM_INPUT: The procedure column is an input parameter. (ODBC 1.0)</li> <li>SQL_PARAM_INPUT_OUTPUT: The procedure column is an input/output parameter. (ODBC 1.0)</li> <li>SQL_PARAM_OUTPUT: The procedure column is an output parameter. (ODBC 2.0)</li> <li>SQL_RETURN_VALUES: The procedure column is a return value of the procedure. (ODBC 2.0)</li> <li>SQL_RESULT_COL: The procedure column is a column of result set. (ODBC 1.0)</li> </ul>
DATA_TYPE (ODBC 1.0)	6	Smallint not NULL	It is SQL data type. For datetime and interval data type, this column returns a concise data type such as SQL_TYPE_DATE, SQL_INTERVAL_YEAR_TO_MONTH.
TYPE_NAME (ODBC 2.0)	7	Varchar not NULL	It is the name of a data source dependent data type. For example, it is CHAR(), VARCHAR(), MONEY, LONG VARBINARY or CHAR ( ) FOR BIT DATA. An application should use this name in CREATE TABLE and ALTER TABLE statement.
COLUMN_SIZE (ODBC 2.0)	8	Integer	It is the maximum column size of the data type supported by the server. The maximum precision is returned for the numeric data type, string data type returns the character length, DATETIME data type returns the length of expressed character, INTERVAL data type returns the character length of literal INTERVAL character, and the datatype to which the column size is not applicable returns NULL.
BUFFER_LENGTH (ODBC 1.0)	9	Integer	It is the byte length transferred from SQLGetData or SQLFetch operation when SQL_C_DEFAULT is specified. The size of numeric data can be different from that of the data stored in the data source. For a string or a binary data, this value is as same as COLUMN_SIZE column.

Column name	Column number	Data type	Description
DECIMAL_DIGITS (ODBC 1.0)	10	Smallint	It is the fractional digit in a column of the data source. If the decimal place of the data type can not be applicable, it returns NULL.
NUM_PREC_RADIX (ODBC 2.0)	11	Smallint	It is 2 or 10 for a numeric data type. If it is 2, COLUMN_SIZE and DECIMAL_DIGITS are number of bits allowed for a column. If it is 10, COLUMN_SIZE and DECIMAL_DIGITS are number of digits allowed for a column.  The data type to which NUM_PREC_RADIX can not be applicable returns NULL.
NULLABLE (ODBC 2.0)	12	Smallint not NULL	It is whether the data type allows NULL value. If it is SQL_NULLABLE, the data type allows NULL value. If it is SQL_NO_NULLS, the data type does not allow NULL value. If it is SQL_NULLABLE_UNKNOWN, it is unknown if the column allows NULL value.
REMARKS (ODBC 2.0)	13	Varchar	It is a description about the procedure column.
COLUMN_DEFAULT (ODBC 3.0)	14	Varchar	It is the default value of a column. If this value is enclosed in double quotes, then this column should be interpreted as a string.
SQL_DATA_TYPE (ODBC 3.0)	15	Smallint not NULL	It is the SQL data type value appears in the SQL_DESC_TYPE field of a descriptor. This column is as same as DATA_TYPE column, except for INTERVAL and DATETIME data type. For INTERVAL and DATETIME data types, SQL_DATA_TYPE field in the result set returns SQL_INTERVAL or SQL_DATETIME, and SQL_DATETIME_SUB field returns the subcode for INTERVAL or DATETIME data type.
SQL_DATETIME_SUB (ODBC 3.0)	16	Smallint	It is the subtype code of datetime and interval data types. It returns NULL for other data types.
CHAR_OCTET_LENGTH (ODBC 3.0)	17	Integer	It is the maximum length in byte of character or binary data type column. It returns NULL for other data types.
ORDINAL_POSITION (ODBC 3.0)	18	Integer not NULL	It is the column location in a table.
IS_NULLABLE (ODBC 3.0)	19	Varchar	<ul style="list-style-type: none"> <li>"YES": A column can include NULL.</li> <li>"NO": A column can not include NULL.</li> <li>It returns a string whose length is 0 when it is unknown whether to allow NULL.</li> </ul>

# SQLProcedures

## Conformance

Introduced version: ODBC 1.0

Standards compliance: ODBC

## Overview

SQLProcedures returns the list of procedure names stored in the specified data source. Procedure is a general term used to describe a named object which can be called by using the executable object or input and output parameter.

## Syntax

```
SQLRETURN SQLProcedures(
    SQLHSTMT      StatementHandle,
    SQLCHAR *     CatalogName,
    SQLSMALLINT   NameLength1,
    SQLCHAR *     SchemaName,
    SQLSMALLINT   NameLength2,
    SQLCHAR *     ProcName,
    SQLSMALLINT   NameLength3);
```

## Arguments

### StatementHandle

[Input] It is the statement handle.

### CatalogName

[Input] It is the name of the procedure catalog. If the driver does not support the catalog, it returns an empty string ("") and the procedure does not include catalog. CatalogName can not include the string search pattern.

If SQL\_ATTR\_METADATA\_ID is set to SQL\_TRUE, CatalogName is treated as an identifier, and it is not case sensitive. If it is set to SQL\_FALSE, CatalogName is treated as an ordinary argument literal, and it is case sensitive. For more information, refer to **Arguments of Catalog Function**.

### NameLength1

[Input] It is the length of \*CatalogName in characters.

**SchemaName**

[Input] It is the name of procedure schema. The string search pattern for the schema name. If the driver does not support the schema, it returns an empty string ("") and the procedure does not include the schema. SchemaName can not include the string search pattern.

If SQL\_ATTR\_METADATA\_ID is set to SQL\_TRUE, SchemaName is treated as an identifier, and it is not case sensitive. If it is set to SQL\_FALSE, SchemaName is treated as a pattern value string argument, and it is case sensitive.

**NameLength2**

[Input] It is the length of \*SchemaName in characters.

**ProcName**

[Input] It is the procedure name. This argument can not be a null pointer. ProcName can not include the string search pattern.

If SQL\_ATTR\_METADATA\_ID is set to SQL\_TRUE, ProcName is treated as an identifier, and it is not case sensitive. If it is set to SQL\_FALSE, ProcName is treated as a pattern value string argument, and it is case sensitive.

**NameLength3**

[Input] It is the length of \*ProcName in characters

**Returns**

SQL\_SUCCESS, SQL\_SUCCESS\_WITH\_INFO, SQL\_STILL\_EXECUTING, SQL\_ERROR, SQL\_INVALID\_HANDLE.

**Diagnosis**

SQLSTATE	Error	Description
01000	General warning	It is the driver-specific informational message. (The function returns SQL_SUCCESS_WITH_INFO.)
08S01	Communication link failure	Before the function processing is completed, the connection between the driver and the data source is failed.
24000	Invalid cursor state	The cursor is open in StatementHandle, and SQLFetch or SQLFetchScroll is called.  If SQLFetch or SQLFetchScroll returns SQL_NO_DATA, the driver returns this error. If SQLFetch or SQLFetchScroll does not return SQL_NO_DATA, the driver manager returns this error.  The result set is open in StatementHandle, but SQLFetch or SQLFetchScroll is not called.
		The transaction is rolled back due to a resource deadlock of other transaction

SQLSTATE	Error	Description
40001	Serialization failure	s.
40003	Statement completion unknown	The related connection fails during the function execution and the status of the transaction is not able to be checked.
HY000	General error	It is an error without any specific SQLSTATE.
HY001	Memory allocation error	It is a memory allocation error.
HY009	Invalid use of null pointer	<p>TableName argument is a null pointer.</p> <p>SQL_ATTR_METADATA_ID statement attribute is set to SQL_TRUE, and CatalogName argument is a null pointer.</p> <p>SQLGetInfo with the SQL_CATALOG_NAME information type returns that catalog names are supported.</p> <p>SQL_ATTR_METADATA_ID statement attribute is set to SQL_TRUE, and SchemaName, ProcName or ColumnName argument is a null pointer.</p>
HY010	Function sequence error	<p>The asynchronously executing function is called for the connection handle related to StatementHandle, and this function is still being executed when SQLProcedureColumns is called.</p> <p>SQLExecute, SQLExecDirect, or SQLMoreResults is called for StatementHandle, and SQL_PARAM_DATA_AVAILABLE is returned. This function is called before the data is checked for all connected parameters.</p> <p>The asynchronously executing function is called for StatementHandle, and is still being executed when this function is called.</p> <p>SQLExecute, SQLExecDirect, SQLBulkOperation or SQLSetPos is called for StatementHandle, and SQL_NEED_DATA is returned. This function is called before data is sent for all data-at-execution parameters or columns.</p>
HY013	Memory management error	The internal memory can not be accessed or the available memory size is small.
HY090	Invalid string or buffer length	<p>A name length argument value is smaller than 0 but it is not as same as SQL_NTS.</p> <p>A name length argument value is bigger than the maximum length corresponding to the name.</p>
HY117	Connection is suspended due to unknown transaction state. Only disconnect and read-only functions are allowed.	For more information about the suspended state, refer to <b>SQLEndTran</b> .
		The catalog is specified, but the driver or the data source does not support th

SQLSTATE	Error	Description
HYC00	Optional feature not implemented	<p>e catalog.</p> <p>The schema is specified, but the driver or the data source does not support the schema.</p> <p>The combination of current setting of SQL_ATTR_CONCURRENCY and SQL_ATTR_CURSOR_TYPE statement attributes is not supported by the driver or data source.</p> <p>SQL_ATTR_USE_BOOKMARKS statement attribute is set to SQL_UB_VARIABLE, and SQL_ATTR_CURSOR_TYPE statement attribute is set to the cursor type for the bookmark that is not supported by the driver.</p>
HYT00	Timeout expired	The query timeout is expired before getting the result set from the data source. The timeout can be set via SQL_ATTR_QUERY_TIMEOUT of SQLSetStmtAttr.
HYT01	Connection timeout expired	The connection is expired before the data source responds to the request. The timeout can be set via SQL_ATTR_CONNECTION_TIMEOUT of SQLSetStmtAttr.
IM001	Driver does not support this function	The driver which is related to StatementHandle does not support the function.
IM017	Polling is disabled in asynchronous notification mode	Whenever using the notification model, polling can not be used.
IM018	SQLCompleteAsync has not been called to complete the previous asynchronous operation on this handle.	If the previous function call for the handle returns SQL_STILL_EXECUTING and if the notification mode is activated, then SQLCompleteAsync should be called for the handle to do post processing and complete the operation.

## Description

SQLProcedures lists all procedures in the requested range. A user may or may not have privileges to execute these procedures. Refer SQL\_ACCESSIBLE\_PROCEDURES of SQLGetInfo to check accessibility. If a user selects the procedure which can not be executed, the application should be able to handle the situation. SQLProcedures returns the standard result set, and it is sorted in an order of PROCEDURE\_CAT, PROCEDURE\_SCHEMA, PROCEDURE\_NAME

The following column names are changed in ODBC 3.x. The column name change does not affect the compatibility with the previous version because the application binds by the column number.

ODBC 2.0 column	ODBC 3.x column
-----------------	-----------------

ODBC 2.0 column	ODBC 3.x column
PROCEDURE_QUALIFIER	PROCEDURE_CAT
PROCEDURE_OWNER	PROCEDURE_SCHEM

SQLGetInfo is called together with SQL\_MAX\_CATALOG\_NAME\_LEN, SQL\_MAX\_SCHEMA\_NAME, SQL\_MAX\_PROCEDURE\_NAME\_LEN options in an application to determine the actual column length of PROCEDURE\_CAT, PROCEDURE\_SCHEM, PROCEDURE\_NAME, COLUMN\_NAME

The following table lists the columns in the result set. The additional row after column 8 (PROCEDURE\_TYPE) is defined by the driver. The applications should get access to a specific driver column by performing the countdown from the end of the result set instead of specifying an explicit ordinal position.

Column name	Column number	Data type	Comments
PROCEDURE_CAT (ODBC 2.0)	1	Varchar	It is the procedure catalog name. If it can not be used in the data source, it is NULL. If the driver supports the catalog only for some tables, such as when the drive retrieves the data from another DBMS, it returns an empty string ("") for the table which does not have a catalog.
PROCEDURE_SCHEM (ODBC 2.0)	2	Varchar	It is the procedure schema identifier. If it can not be used in the data source, it is NULL. If the driver supports the schema only for some table, such as when the drive retrieves the data from another DBMS, it returns an empty string ("") for the table which does not have a schema.
PROCEDURE_NAME (ODBC 2.0)	3	Varchar not null	It is the procedure identifier.
REMARK (ODBC 2.0)	4	Varchar	It is the description on the procedure.
PROCEDURE_TYPE (ODBC 2.0)	5	Smallint	It defines a procedure type. <ul style="list-style-type: none"> <li>SQL_PT_UNKNOWN: Where the procedure returns the value or not is unknown.</li> <li>SQL_PT_PROCEDURE: The returned object is a procedure. In other words, a return value does not exist.</li> <li>SQL_PT_FUNCTION: The returned object is a function. In other words, a return value exists.</li> </ul>

# SQLPutData

## Conformance

Introduced version: ODBC 1.0

Standards compliance: ISO 92

## Overview

SQLPutData allows the application to transfer a parameter to the driver or transfer the data to a column at statement execution time.

The function can be used to transfer a character or binary data value in parts to a column with a character, binary, or data source specific data type (For example, the parameter of SQL\_LONGVARBINARY or SQL\_LONGVARCHAR types).

Even if the default driver does not support unicode, SQLPutData supports the binding to Unicode C data types.

## Syntax

```
SQLRETURN SQLPutData(  
    SQLHSTMT    StatementHandle,  
    SQLPOINTER  DataPtr,  
    SQLLEN      StrLen_or_Ind);
```

## Arguments

### StatementHandle

[Input] It is the statement handle.

### DataPtr

[Input] It is the buffer pointer which includes the actual data for the parameter or column. The data should be the C data types specified by ValueType argument of SQLBindParameter (parameter data) or TargetType argument of SQLBindCol (column data).

### StrLen\_or\_Ind

[Input] It is the length of \*DataPtr. It specifies the amount of data transferred to SQLPutData call. The amount of data can be varied depending on each call to the given parameter or the column. StrLen\_or\_Ind is ignored if one of the following conditions is not satisfied.

- StrLen\_or\_Ind is SQL\_NTS, SQL\_NULL\_DATA, or SQL\_DEFAULT\_PARAM.



- The C data type that is specified in `SQLBindParameter` or `SQLBindCol` is `SQL_C_CHAR` or `SQL_C_BINARY`.
- The C data type is `SQL_C_DEFAULT`, and the default C data type for the specified SQL data type is `SQL_C_CHAR` or `SQL_C_BINARY`.

For all other types of C data, if `StrLen_or_Ind` is not `SQL_NULL_DATA` or `SQL_DEFAULT_PARAM`, the driver determines that the size of `*DataPtr` is the size of C data type specified in `ValueType` or `TargetType`, and transfers the entire data value.

## Returns

`SQL_SUCCESS`, `SQL_SUCCESS_WITH_INFO`, `SQL_STILL_EXECUTING`, `SQL_ERROR`, `SQL_INVALID_HANDLE`

## Diagnosis

SQLSTATE	Error	Description
01000	General warning	It is the driver-specific informational message. (The function returns <code>SQL_SUCCESS_WITH_INFO</code> .)
01004	String data, right truncated	The string or binary data returned to the input/output or output parameters are truncated. If a string is truncated, the right part of the string is truncated. (The function returns <code>SQL_SUCCESS_WITH_INFO</code> .)
07006	Restricted data type attribute violation	The data value identified by the <code>ValueType</code> argument in <code>SQLBindParameter</code> for the bound parameter can not be converted to the data type identified by the <code>ParameterType</code> argument in <code>SQLBindParameter</code> .
07S01	Invalid use of default parameter	The parameter value set in <code>SQLBindParameter</code> is <code>SQL_DEFAULT_PARAM</code> , and the corresponded parameter does not have the default value.
08S01	Communication link failure	Before the function processing is completed, the connection between the driver and the data source is failed.
22001	String data, right truncation	The string or binary data is truncated.  <code>SQL_NEED_LONG_DATA_LEN</code> information type is "Y" in <code>SQLGetInfo</code> , and more data is transferred for a long parameter than is specified with <code>StrLen_or_IndPtr</code> argument in <code>SQLBindParameter</code> .  <code>SQL_NEED_LONG_DATA_LEN</code> information type is "Y" in <code>SQLGetInfo</code> , and more data is transferred for a long column than is specified in the buffer length corresponding to the data rows which are added or updated with <code>SQLBulkOperation</code> or updated with <code>SQLSetPos</code> .
22003	Numeric value out of range	The bound numeric parameter or the data which is transferred to the column causes the truncation for the numeric value when the related table column is allocated.  The numeric value which is returned for the input/output parameter or output parameter is truncated.

SQLSTATE	Error	Description
22007	Invalid datetime format	<p>The data sent for a parameter or column which is bound to a date, time, or timestamp structure is invalid for each type.</p> <p>An input/output or output parameter is bound to a date, time, or timestamp C structure, and a value in the returned parameter is invalid for each type. (The function returns SQL_SUCCESS_WITH_INFO.)</p>
22008	Datetime field overflow	DATETIME expression is not valid for the bound DATE, TIME or TIMESTAMP C structure.
22012	Division by zero	An arithmetic expression calculated for an input/output or output parameter is in divided by zero.
22015	Interval field overflow	<p>The significant digits are lost due to the data transfer for an exact numeric or interval column or parameter to an interval SQL data type.</p> <p>The data transferred to one or more INTERVAL columns or parameters is converted into a numeric data type, but it can not be expressed as a numeric data type.</p> <p>The data transferred for the column or parameter data is assigned to INTERVAL SQL type, but it can not be expressed as the value of C type in INTERVAL SQL type.</p> <p>The significant digits of the data transferred for the exact number or the INTERVAL C column or parameter are lost.</p> <p>The data transferred for the column or parameter data is assigned to INTERVAL C type, but it can not be expressed as INTERVAL data structure.</p>
22018	Invalid character value for cast specification	<p>The character not represented as the character set of C buffer is included in the character column of the result set.</p> <p>The C type is the exact or approximate numeric, datetime, interval data type, and if the SQL type is the character data type, then the value of the column bound to the C type is invalid.</p>
HY000	General error	It is an error without any specific SQLSTATE.
HY001	Memory allocation error	It is a memory allocation error.
HY008	Operation canceled	<p>Asynchronous processing for StatementHandle is available and SQLCancel or SQLCancelHandle is called on StatementHandle before the function is called and completed. Then, this function is called again on StatementHandle.</p> <p>SQLCancel or SQLCancelHandle is called on StatementHandle from other thread in the multithreaded application before this function is called and completed.</p>
HY009	Invalid use of null	DataPtr argument is a null pointer, and StrLen_or_Ind argument is neither S

SQLSTATE	Error	Description
	pointer	QL_DEFAULT_PARAM nor SQL_NULL_DATA.
HY010	Function sequence error	<p>The previous function is not a call to SQLPutData or SQLParamData.</p> <p>The asynchronously executing function is called for the connection handle related to StatementHandle, but it is still being asynchronously executed when SQLPrimaryKeys is called.</p> <p>The asynchronously executing function is called for StatementHandle, but it is still being asynchronously executed when the function is called.</p> <p>SQLExecute, SQLExecDirect, SQLBulkOperation or SQLSetPos is called for StatementHandle, and SQL_NEED_DATA is returned. This function is called before data is sent for all data-at-execution parameters or columns.</p>
HY013	Memory management error	The internal memory can not be accessed or the available memory size is small.
HY019	Non-character and non-binary data sent in pieces	SQLPutData is called for the parameter or column one or more times, and it is not used to transfer the character C data to a column with the character, the binary or the data source-specific data type, or to transfer the binary C data to a column with the character, the binary or the data source-specific data type.
HY020	Attempt to concatenate a null value	SQLPutData is called once or more after SQL_NEED_DATA is returned, and StrLen_or_Ind argument includes SQL_NULL_DATA or SQL_DEFAULT_PARAM in one of these calls.
HY090	Invalid string or buffer length	DataPtr argument is not a null pointer, and StrLen_or_Ind is not equal to SQL_NTS or SQL_NULL_DATA, or is smaller than 0.
HY117	Connection is suspended due to unknown transaction state. Only disconnect and read-only functions are allowed.	For more information about the suspended state, refer to <b>SQLEndTran</b> .
HYT01	Connection timeout expired	The connection is expired before the data source responds to the request. The timeout can be set via SQL_ATTR_CONNECTION_TIMEOUT of SQLSetStmtAttr.
IM001	Driver does not support this function	The driver related to StatementHandle does not support the function.
IM017	Polling is disabled in asynchronous notification mode	Whenever using the notification model, polling can not be used.
	SQLCompleteAsy	

SQLSTATE	Error	Description
IM018	nc has not been called to complete the previous asynchronous operation on this handle.	If the previous function call for the handle returns SQL_STILL_EXECUTING and if the notification mode is activated, then SQLCompleteAsync should be called for the handle to do post processing and complete the operation.

## Description

SQLPutData can be called to provide data-at-execution data for two uses. One is to use it as parameter data when calling SQLExecute or SQLExecDirect. The other is to use it as column data when updating or adding a row by calling SQLBulkOperations, or when updating a row by calling SQLSetPos.

When the application calls SQLParamData to determine which data should be transferred, the driver returns an indicator that the application can use to determine which parameter data to send or where column data can be found. The function also returns SQL\_NEED\_DATA which is an indicator to the application that it should call SQLPutData to transfer the data. In the DataPtr argument to SQLPutData, the application passes a pointer to the buffer including the actual data for the parameter or column.

When the driver returns SQL\_SUCCESS for SQLPutData, the application calls SQLParamData again. For transferring more data, SQLParamData returns SQL\_NEED\_DATA, and the application calls SQLPutData again. If all data-at-execution data are transferred, SQL\_SUCCESS is returned. And then the application calls SQLParamData again. If the driver returns SQL\_NEED\_DATA and another marker in \*ValuePtrPtr, then it requests the data for other parameter or column and calls SQLPutData again. If the driver returns SQL\_SUCCESS, then all data-at-execution data are transferred, and the SQL statement can be executed or SQLBulkOperations or SQLSetPos can be processed.



The application is allowed to use SQLPutData only when the character C data or binary C data is transferred to the character, binary or data source specific data type. If SQLPutData is called once or more under different conditions, SQL\_ERROR and SQLSTATE HY019 are returned. (Non-character and non-binary data sent in pieces)

# SQLRowCount

## Conformance

Introduced version: ODBC 1.0

Standards compliance: ISO 92

## Overview

SQLRowCount returns the number of rows which are affected by UPDATE, INSERT, or DELETE statement. (SQL\_ADD, SQL\_UPDATE\_BY\_BOOKMARK or SQL\_DELETE\_BY\_BOOKMARK operation in SQLBulkOperations. Or SQL\_UPDATE or SQL\_DELETE operation in SQLSetPos)

## Syntax

```
SQLRETURN SQLRowCount(
    SQLHSTMT StatementHandle,
    SQLLEN * RowCountPtr);
```

## Arguments

### StatementHandle

[Input] It is the statement handle.

### RowCountPtr

[Output] It is the buffer pointer to which the number of rows is to be returned. For UPDATE, INSERT, DELETE statements, for the SQL\_ADD, SQL\_UPDATE\_BY\_BOOKMARK, SQL\_DELETE\_BY\_BOOKMARK operations in SQLBulkOperations, and for the SQL\_UPDATE or SQL\_DELETE operations in SQLSetPos, the value returned to \*RowCountPtr is the number of rows affected by the request. Or, it is -1 if the number of affected rows is not available.

When SQLExecute, SQLExecDirect, SQLBulkOperations, SQLSetPos or SQLMoreResults is called, SQL\_DIAG\_ROW\_COUNT field of the diagnostic data structure is set to the number of rows, and the number of rows are cached in a way that depends on the implementation. SQLRowCount returns the number of cached rows. The number of cached rows are valid until when the statement handle is set again in the prepared or assigned state, or when the statement is executed again or when SQLCloseCursor is called. If SQL\_DIAG\_ROW\_COUNT field is set and the function is called, then SQL\_DIAG\_ROW\_COUNT field is set to 0 by calling any function, and the return value by SQLRowCount can be different from the value in SQL\_DIAG\_ROW\_COUNT field.

For other statements and functions, the driver can define the value returned in \*RowCountPtr. For

example, some data source can return the number of rows returned by SELECT statement before rows are patched.

## Returns

SQL\_SUCCESS, SQL\_SUCCESS\_WITH\_INFO, SQL\_ERROR, SQL\_INVALID\_HANDLE

## Diagnosis

SQLSTATE	Error	Description
01000	General warning	It is the driver-specific informational message. (The function returns SQL_SUCCESS_WITH_INFO.)
HY000	General error	It is an error without any specific SQLSTATE.
HY001	Memory allocation error	It is a memory allocation error.
HY010	Function sequence error	<p>The asynchronously executing function is called for the connection handle related to StatementHandle, and this function is still being executed when SQLRowCount is called.</p> <p>SQLExecute, SQLExecDirect, SQLMoreResults is called for StatementHandle, and SQL_PARAM_DATA_AVAILABLE is returned. The function is called before data is retrieved for all streamed parameters.</p> <p>The function is called for StatementHandle, before SQLExecute, SQLExecDirect, SQLBulkOperations, or SQLSetPos is called.</p> <p>The asynchronously executing function is called for StatementHandle, and this function is still being executed when this function is called.</p> <p>SQLExecute, SQLExecDirect, SQLBulkOperation or SQLSetPos are called for StatementHandle, and SQL_NEED_DATA is returned. This function is called before data is sent for all data-at-execution parameters or columns.</p>
HY013	Memory management error	The internal memory can not be accessed or the available memory size is small.
HY117	Connection is suspended due to unknown transaction state. Only disconnect and read-only functions are allowed.	For more information about the suspended state, refer to <b>SQLEndTran</b> .
HYT00	Timeout expired	The query timeout is expired before getting the entire result set from the data source. The timeout can be set via SQL_ATTR_QUERY_TIMEOUT of SQLSetStmtAttr.
HYT01	Connection timeout expired	The connection is expired before the data source responds to the request. The timeout can be set via SQL_ATTR_CONNECTION_TIMEOUT of SQLSet

SQLSTATE	Error	Description
	red	StmtAttr.
IM001	Driver does not support this function	The driver which is related to StatementHandle does not support the function.

## Description

If the last SQL statement executed for the statement handle is not UPDATE, INSERT, DELETE, or if an operation argument of the previous SQLBulkOperations call is not SQL\_ADD, SQL\_UPDATE\_BY\_BOOKMARK, SQL\_DELETE\_BY\_BOOKMARK or if an operation argument of the previous SQLSetPos call is not SQL\_UPDATE, SQL\_DELETE, then the value of \*RowCountPtr is defined by the driver.

# SQLSetConnectAttr

## Conformance

Introduced version: ODBC 3.0

Standards compliance: ISO 92

## Overview

SQLSetConnectAttr sets the attribute which controls the connection.

## Syntax

```
SQLRETURN SQLSetConnectAttr(  
    SQLHDBC      ConnectionHandle,  
    SQLINTEGER   Attribute,  
    SQLPOINTER   ValuePtr,  
    SQLINTEGER   StringLength);
```

## Arguments

### ConnectionHandle

[Input] It is the connection handle.

### Attribute

[Input] It is the attribute for setting.

### ValuePtr

[Input] It is the pointer of the value related to attribute. According to the value of attribute, ValuePtr can be an unsigned integer or it points to a null-termination string. The integer type of attribute argument may not be the fixed length data type. For more information, refer to the Description section.

### StringLength

[Input] If attribute is the ODBC-defined attribute and ValuePtr points to the string or binary buffer, then the argument should be the length of \*ValuePtr. For string data, the argument should include the number of bytes of the string.

If attribute is the ODBC-defined attribute and ValuePtr is an integer, then StringLength is ignored.

If attribute is the driver-defined attribute, then the application indicates the attribute characteristics set by StringLength argument to the driver manager. StringLength may have one of the following v



alues:

- If ValuePtr is a string pointer, StringLength is the string length or SQL\_NTS.
- If ValuePtr is a binary buffer pointer, the application stores the result of SQL\_LEN\_BINARY\_ATTR (length) macro which is a negative value in StringLength.
- If ValuePtr is neither string pointer nor binary buffer pointer, StringLength must have SQL\_IS\_POINTER.
- If ValuePtr contains the fixed length value, StringLength is SQL\_IS\_INTEGER or SQL\_IS\_UNSIGNED.

## Returns

SQL\_SUCCESS, SQL\_SUCCESS\_WITH\_INFO, SQL\_ERROR, SQL\_INVALID\_HANDLE, SQL\_STILL\_EXECUTING

## Diagnosis

SQLSTATE	Error	Description
01000	General warning	It is the driver-specific informational message. (The function returns SQL_SUCCESS_WITH_INFO.)
01S02	Option value changed	The value specified in ValuePtr is not supported by the driver and it is replaced with a similar value. (The function returns SQL_SUCCESS_WITH_INFO.)
08002	Connection name in use	Attribute argument is SQL_ATTR_ODBC_CURSORS, and the driver is already connected to the data source.
08003	Connection not open	Attribute value is assigned to request an open connection, but ConnectionHandle is not in a connected state.
08S01	Communication link failure	Before the function processing is completed, the connection between the driver and the data source is failed.
24000	Invalid cursor state	Attribute argument is SQL_ATTR_CURRENT_CATALOG, and the result set is deferred.
25000	Illegal operation while in a local transaction	The local transaction is connected while attempting to connect the distributed transaction by setting of the connection attribute SQL_ATTR_ENLIST_IN_DTC. The connection to the distributed transaction is already enlisted. The connection to the distributed transaction is already enlisted, the local transaction is started by setting SQL_ATTR_AUTOCOMMIT to SQL_AUTOCOMMIT_OFF.
3D000	Invalid catalog name	Attribute argument is SQL_ATTR_CURRENT_CATALOG and the specified catalog name is not valid.
HY000	General error	It is an error without any specific SQLSTATE.
HY001	Memory allocation	It is a memory allocation error.

SQLSTATE	Error	Description
	n error	
HY008	Operation cancelled	<p>The asynchronous processing is activated for ConnectionHandle. The SQLSetConnectAttr function is called, and before it completes execution, the SQLCancelHandle function is called on the ConnectionHandle, and then the SQLSetConnectAttr function is called again on the ConnectionHandle.</p> <p>Or, SQLSetConnectAttr function is called, and before it completes execution, SQLCancelHandle is called on the ConnectionHandle from a different thread in a multithread application.</p>
HY009	Invalid use of null pointer	Attribute argument identifies the connection attribute which requires the string value, and ValuePtr argument is a null pointer.
HY010	Function sequence error	<p>The asynchronously executing function is called for the statementHandle related to ConnectionHandle, and this function is still being executed when SQLSetConnectAttr is called.</p> <p>The asynchronously executing function is called for the ConnectionHandle, and this function is still being executed when this function is called.</p> <p>SQLExecute, SQLExecDirect, SQLMoreResults is called for one of StatementHandle related to ConnectionHandle, and SQL_PARAM_DATA_AVAILABLE is returned. The function is called before data is retrieved for all streamed parameters.</p> <p>SQLExecute, SQLExecDirect, SQLBulkOperation or SQLSetPos are called for StatementHandle related to ConnectionHandle, and SQL_NEED_DATA is returned. This function is called before data is sent for all data-at-execution parameters or columns.</p> <p>SQLBrowseConnect is called for ConnectionHandle, and SQL_NEED_DATA is returned. The function is called before SQLBrowseConnect returns SQL_SUCCESS_WITH_INFO or SQL_SUCCESS.</p>
HY011	Attribute cannot be set now	Attribute argument is SQL_ATTR_TXN_ISOLATION, and the transaction is open.
HY013	Memory management error	The internal memory can not be accessed or the available memory size is small.
HY024	Invalid attribute value	<p>The specified Attribute value is assigned, and the invalid value is specified to ValuePtr.</p> <p>Attribute argument is SQL_ATTR_TRACEFILE or SQL_ATTR_TRANSLATE_LIB, and ValuePtr is an empty string.</p>
HY090	Invalid string or buffer length	ValuePtr is a string and StringLength argument is smaller than 0 but it is not SQL_NTS.
	Driver does not support connectio	The application tries to activate asynchronous execution with SQL_ATTR_AS

SQLSTATE	Error	Description
HY114	n-level asynchronous function execution	YNC_DBC_FUNCTIONS_ENABLE when the driver does not support asynchronous connection.
HY117	Connection is suspended due to unknown transaction state. Only disconnect and read-only functions are allowed.	For more information about the suspended state, refer to <b>SQLEndTran</b> .
HY121	Cursor Library and Driver-Aware Pooling cannot be enabled at the same time	It is not supported by the driver.
HYC00	Optional feature not implemented	The value specified for Attribute argument is valid for the ODBC connection or the statement attribute for the version supported by the driver, but it is not supported by the driver.
HYT01	Connection timeout expired	The connection is expired before the data source responds to the request. The timeout can be set via SQL_ATTR_CONNECTION_TIMEOUT of SQLSetStmtAttr.
IM001	Driver does not support this function	The driver which is related to ConnectionHandle does not support the function.
IM009	Unable to load translation DLL	The driver can not load the transaction DDL specified for the connection. The error can be returned only when attribute is SQL_ATTR_TRANSLATE_LIB.
IM017	Polling is disabled in asynchronous notification mode	Whenever using the notification model, polling can not be used.
IM018	SQLCompleteAsync has not been called to complete the previous asynchronous operation on this handle.	If the previous function call for the handle returns SQL_STILL_EXECUTING and if the notification mode is activated, then SQLCompleteAsync should be called for the handle to do post processing and complete the operation.
S1118	Driver does not support asynchronous notification	SQL_ATTR_ASYNC_DBC_EVENT is set but the asynchronous notification is not supported by the driver.

## Description

The application can call `SQLSetConnectAttr` at any time between the connection is assigned and released. All connections and the statement attributes set by the application for connection are maintained until `SQLFreeHandle` is called. For example, if an application calls `SQLSetConnectAttr` before connecting to a data source, the attribute is maintained even when `SQLSetConnectAttr` fails in the driver when the application connects to the data source. If the application sets the driver-specific attribute then the attribute is maintained even when the application connects to a different driver.



The feature to set the statement attribute at the connection level by `SQLSetConnectAttr` call is not used in ODBC 3.x. ODBC 3.x application should not set the statement attribute at the connection level. ODBC 3.x application can not set the statement attributes except for `SQL_ATTR_METADATA_ID` and `SQL_ATTR_ASYNC_ENABLE` attributes at the connection level. The two attributes are both the connection attribute and statement attribute and they can be set at the connection level or statement level. If ODBC 3.x driver operates with ODBC 2.x application which sets the ODBC 2.x statement option at the connection level, the ODBC 3.x driver is required to support it.

Some connection attributes can be set only before the connection is made, and some other attributes can be set only after the connection is made. The following table describes these connection attributes.

Attribute	Whether it is set before or after connection
<code>SQL_ATTR_ACCESS_MODE</code>	Either[1]
<code>SQL_ATTR_ASYNC_DBC_EVENT</code>	Either
<code>SQL_ATTR_ASYNC_DBC_FUNCTIONS_ENABLE</code>	Either[4]
<code>SQL_ATTR_ASYNC_DBC_PCALLBACK</code>	Either
<code>SQL_ATTR_ASYNC_DBC_PCONTEXT</code>	Either
<code>SQL_ATTR_ASYNC_ENABLE</code>	Either[2]
<code>SQL_ATTR_AUTO_IPD</code>	Either
<code>SQL_ATTR_AUTOCOMMIT</code>	Either[5]
<code>SQL_ATTR_CONNECTION_DEAD</code>	After
<code>SQL_ATTR_CONNECTION_TIMEOUT</code>	Either
<code>SQL_ATTR_CURRENT_CATALOG</code>	Either[1]
<code>SQL_ATTR_DBC_INFO_TOKEN</code>	After
<code>SQL_ATTR_ENLIST_IN_DTC</code>	After
<code>SQL_ATTR_LOGIN_TIMEOUT</code>	Before
<code>SQL_ATTR_METADATA_ID</code>	Either
<code>SQL_ATTR_OLDPWD</code>	Before
<code>SQL_ATTR_ODBC_CURSORS</code>	Before
<code>SQL_ATTR_PACKET_SIZE</code>	Before

Attribute	Whether it is set before or after connection
SQL_ATTR_QUIET_MODE	Either
SQL_ATTR_TRACE	Either
SQL_ATTR_TRACEFILE	Either
SQL_ATTR_TRANSLATE_LIB	After
SQL_ATTR_TRANSLATE_OPTION	After
SQL_ATTR_TXN_ISOLATION	Either <sup>[3]</sup>

[1] SQL\_ATTR\_ACCESS\_MODE and SQL\_ATTR\_CURRENT\_CATALOG can be set before and after the connection according to the driver. But the application which uses multiple drivers should set before the connection because these changes are not supported after the connection depending on the driver.

[2] SQL\_ATTR\_ASYNC\_ENABLE should be set before the statement is activated.

[3] SQL\_ATTR\_TXN\_ISOLATION can be set only when there is not any open transaction on the connection. Some connection attributes is supported by replacing with the similar value if the data source does not support the value specified by \*ValuePtr. In this case, the driver returns SQL\_SUCCESS\_WITH\_INFO and SQLSTATE 01S02 (Option value changed). For example, if Attribute is SQL\_ATTR\_PACKET\_SIZE and \*ValuePtr exceeds the maximum packet size, the driver replaces it with the maximum packet size, the application calls SQLSetConnectAttr to check the replaced value.

[4] If SQL\_ATTR\_ASYNC\_DBC\_FUNCTIONS\_ENABLE is set before the connection is open, the driver manager sets the driver attribute when the driver is loaded while SQLBrowseConnect, SQLConnect, or SQLDriverConnect is called. Before SQLBrowseConnect, SQLConnect, or SQLDriverConnect is called, the driver manager does not know which driver is connected and does not know whether the driver supports the asynchronous operation for connection. Therefore, the driver manager returns SQL\_SUCCESS. However if the driver does not support the asynchronous operation for connection, then calling SQLBrowseConnect, SQLConnect, or SQLDriverConnect will fail.

[5] If SQL\_ATTR\_AUTOCOMMIT is set to FALSE and API returns SQL\_ERROR, the application should call SQLEndTran (SQL\_ROLLBACK) to guarantee the transaction consistency.

Information type in \*ValuePtr buffer depends on the specified attribute. SQLSetConnectAttr accepts one of the null-termination character or integer value as attribute information. The character string indicated to by the ValuePtr argument of SQLSetConnectAttr has StringLength bytes length.

If the length is defined in the attribute, StringLength argument is ignored as is the case of all attributes introduced in ODBC 2.x or the previous version.

Attribute	ValuePtr contents
	It is an SQLINTEGER value. SQL_MODE_READ_WRITE is the default value. SQL_MODE_READ_ONLY is used in the driver or data source as an indicator of which the conn

Attribute	ValuePtr contents
SQL_ATTR_ACCESS_MODE (ODBC 1.0)	Action is not requested to support SQL statement which causes update to occur. The mode can be used to optimize the proper lock strategy, transaction management or other area for the driver or the data source. The driver is not required to prevent such information which is sent to the data source. The behavior of the driver and data source when asked to process SQL statements which are not read-only during a read-only connection is implementation-defined.
SQL_ATTR_ASYNC_DBC_EVENT (ODBC 3.8)	It is not supported by the driver.
SQL_ATTR_ASYNC_DBC_FUNCTIONS_ENABLE (ODBC 3.8)	It is not supported by the driver.
SQL_ATTR_ASYNC_DBC_PCALLBACK (ODBC 3.8)	It is not supported by the driver.
SQL_ATTR_ASYNC_DBC_PCONTEXT (ODBC 3.8)	It is not supported by the driver..
SQL_ATTR_ASYNC_ENABLE (ODBC 3.0)	It is not supported by the driver.
SQL_ATTR_AUTO_IPD (ODBC 3.0)	It is not supported by the driver.
SQL_ATTR_AUTOCOMMIT (ODBC 1.0)	<p>It is an SQLINTEGER value which specifies whether to use the auto-commit or manual commit mode.</p> <ul style="list-style-type: none"> <li>• SQL_AUTOCOMMIT_OFF: The driver uses the manual commit mode, and the application should explicitly commit or roll back the transaction with SQLEndTran.</li> <li>• SQL_AUTOCOMMIT_ON: The driver uses the auto-commit mode. Each statement is immediately executed and committed. All open transactions in the connection are committed when SQL_ATTR_AUTOCOMMIT is set to SQL_AUTOCOMMIT_ON.</li> </ul> <p>Some data sources remove the access plan at the time of when the statement is committed to the connection and close the cursor. It may occur in auto commit mode after each non-query statements are executed or after the cursor is closed for the query. For more information, refer to SQL_CURSOR_COMMIT_BEHAVIOR and SQL_CURSOR_ROLLBACK_BEHAVIOR information type of <b>SQLGetInfo</b>.</p> <p>The batch can be executed in auto commit mode in two ways. The entire batch can be treated as the automatic processing unit, or each statement in a batch can be treated as the automatic processing unit. A particular data source may support both of these ways or it may select one and support it. The driver defines the entire batch or each statement in the batch processing can be treated as the automatic processing unit.</p>
SQL_ATTR_CONNECTION_DEAD(ODBC 3.5)	It is not supported by the driver.
SQL_ATTR_CONNECTION_	

Attribute	ValuePtr contents
TIMEOUT (ODBC 3.0)	It is not supported by the driver.
SQL_ATTR_CURRENT_CATALOG (ODBC 2.0)	It is not supported by the driver.
SQL_ATTR_DBC_INFO_TOKEN (ODBC 3.8)	It is not supported by the driver.
SQL_ATTR_ENLIST_IN_DTC (ODBC 3.0)	It is not supported by the driver.
SQL_ATTR_LOGIN_TIMEOUT (ODBC 1.0)	<p>It is SQLINTEGER value corresponding to a wait time, in seconds, until the login request is completed before returning to the application. The default value depends on the driver. If ValuePtr is 0, the time limit is deactivated and the connection attempt will indefinitely wait.</p> <p>If the specified login request timeout exceeds the maximum login time limit, then the driver replaces the value and returns SQLSTATE 01S02 (Option value changed).</p>
SQL_ATTR_METADATA_ID (ODBC 3.0)	<p>It is SQLINTEGER value which determines how to handle the string argument of the catalog function. The default value is SQL_FALSE.</p> <p>If it is SQL_TRUE, string argument of the catalog function is regarded as an identifier and it is not case-sensitive. For a non-delimited string, the driver removes all trailing spaces and changes the string to uppercase. For a delimited string, the driver removes leading or trailing spaces and still has the character between delimiters. If one of these arguments is a null pointer, the function returns SQL_ERROR and SQLSTATE HY009 (Invalid use of null pointer).</p> <p>If it is SQL_FALSE, string argument of the catalog function is not regarded as an identifier and it is case-sensitive. So it may be processed as a string pattern according to the argument, or not.</p> <p>TableType argument of SQLTables which has the value list is not affected by the attribute.</p> <p>SQL_ATTR_METADATA_ID can be set in the statement step. (It is the unique connection attribute in the statement attribute.)</p> <p>For more information, refer to <b>Arguments of Catalog Function</b>.</p>
SQL_ATTR_OLDPWD	It is SQLPOINTER for the previous encrypted string. The value is write only, and it should be set prior to connecting to the server.
SQL_ATTR_ODBC_CURSORS (ODBC 2.0)	It is not supported by the driver.
SQL_ATTR_PACKET_SIZE (ODBC 2.0)	It is not supported by the driver.
SQL_ATTR_QUIET_MODE (ODBC 2.0)	It is not supported by the driver.

Attribute	ValuePtr contents
SQL_ATTR_TRACE (ODBC 1.0)	It is not supported by the driver.
SQL_ATTR_TRACEFILE (ODBC 1.0)	It is not supported by the driver.
SQL_ATTR_TRANSLATE_LIB (ODBC 1.0)	It is not supported by the driver.
SQL_ATTR_TRANSLATE_OPTION (ODBC 1.0)	It is not supported by the driver.
SQL_ATTR_TXN_ISOLATION (ODBC 1.0)	<p>It is 32-bit bit mask for setting the transaction isolation level for the current connection. The application should call <code>SQLEndTran</code> by using this option before calling <code>SQLSetConnectAttr</code> to commit or roll back all open transactions on connection.</p> <p>The valid value for ValuePtr can be determined by calling <code>SQLGetInfo</code> with InfoType which is equal to <code>SQL_TXN_ISOLATION_OPTIONS</code>.</p> <p>For more information about the transaction isolation level, refer to <code>SQL_DEFAULT_TXN_ISOLATION</code> information type of <code>SQLGetInfo</code>.</p>

[1] The function can be asynchronously called only when the descriptor is the implementation descriptor, but not the application descriptor.



# SQLSetConnectOption

## Conformance

Introduced version: ODBC 1.0

Standards compliance: It is not available.

## Overview

ODBC 2.0 function `SQLSetConnectOption` is replaced with `SQLSetConnectAttr` in ODBC 3.x. For more information, refer to `SQLSetConnectAttr`.

# SQLSetCursorName

## Conformance

Introduced version: ODBC 1.0

Standards compliance: ISO 92

## Overview

SQLSetCursorName connects the cursor name to the activated statement. If the application does not call SQLSetCursorName, then the driver generates the cursor name which is necessary to the SQL statement processing.

## Syntax

```
SQLRETURN SQLSetCursorName(  
    SQLHSTMT      StatementHandle,  
    SQLCHAR *     CursorName,  
    SQLSMALLINT   NameLength);
```

## Arguments

### StatementHandle

[Input] It is the statement handle.

### CursorName

[Input] It is the cursor name. A cursor name should not contain leading or trailing spaces for efficient processing, and if the cursor name includes a limited identifier, then the delimiter should be positioned on the first letter of the cursor name.

### NameLength

[Input] It is the string length of \*CursorName.

## Returns

SQL\_SUCCESS, SQL\_SUCCESS\_WITH\_INFO, SQL\_ERROR, SQL\_INVALID\_HANDLE

## Diagnosis

SQLSTATE	Error	Description
01000	General warning	It is the driver-specific informational message. (The function returns SQL_SUCCESS_WITH_INFO.)
01004	String data, right truncated	The cursor name length exceeds the maximum, and only the string of the maximum allowable number is used.
24000	Invalid cursor state	The statement corresponding to StatementHandle is already running or it is in use as the to a positioning cursor.
34000	Invalid cursor name	The cursor name specified in *CursorName exceeds the maximum value of the driver, or it is not valid because it is started with SQLCUR or SQL_CUR.
3C000	Duplicate cursor name	The name specified in *CursorName already exists.
HY000	General error	It is an error without any specific SQLSTATE.
HY001	Memory allocation error	It is a memory allocation error.
HY009	Invalid use of null pointer	CursorName argument is a NULL pointer.
HY010	Function sequence error	<p>The asynchronously executing function is called for the connection handle related to StatementHandle, and this function is still being executed when SQLSetCursorName is called.</p> <p>SQLSetCursorName function is called and the asynchronously executing function is called for StatementHandle.</p> <p>SQLExecute, SQLExecDirect, SQLBulkOperation or SQLSetPos are called for StatementHandle, and SQL_NEED_DATA is returned. This function is called before data is sent for all data-at-execution parameters or columns.</p>
HY013	Memory management error	The internal memory can not be accessed or the available memory size is small.
HY090	Invalid string or buffer length	NameLength argument is smaller than 0. (It is not SQL_NTS.)
HY117	Connection is suspended due to unknown transaction state. Only disconnect and read-only functions are allowed.	For more information about the suspended state, refer to <b>SQLEndTran</b> .
HYT01	Connection timeout expired	The connection timeout period is expired before the data source responds to the request. The timeout can be set through SQL_ATTR_CONNECTION_TIMEOUT of SQLSetConnectAttr.
IM001	Driver does not support this function	The driver does not support the function.

## Description

The cursor name is used for positioning update statements and positioning delete statements. (e.g. UPDATE table-name ... WHERE CURRENT OF cursor-name). If the application does not define the cursor name by calling `SQLSetCursorName` in the execution of query statement, then the driver generates the name which starts with `SQL_CUR` and does not exceed a length of 18 characters.

All cursor names should be unique within a connection. The maximum length of the cursor name is defined in the driver. For maximum interoperability, it is recommended that the application limit the cursor name of more than 18 characters. In ODBC 3.x, if the cursor name is enclosed in double quotes ("), it is considered to be case sensitive and it is not allowed by SQL syntax or it can include the specially treated characters like space or reserved word. The case-sensitive cursor name should be enclosed with double quotes (") identifier.

The cursor name remains until the related statement is deleted by using `SQLFreeHandle`. `SQLSetCursorName` can be called to rename a cursor on a statement when the cursor is in an allocated or prepared state.

# SQLSetDescField

## Conformance

Introduced version: ODBC 3.0

Standards compliance: ISO 92

## Overview

SQLSetDescField sets the value of a single field of the descriptor record.

## Syntax

```
SQLRETURN SQLSetDescField(  
    SQLHDESC      DescriptorHandle,  
    SQLSMALLINT   RecNumber,  
    SQLSMALLINT   FieldIdentifier,  
    SQLPOINTER    ValuePtr,  
    SQLINTEGER    BufferLength);
```

## Arguments

### DescriptorHandle

[Input] It is the descriptor handle.

### RecNumber

[Input] It points to the descriptor record including a field which the application seeks to set. The descriptor records are numbered from 0 and the record number 0 is the bookmark record. RecNumber argument is ignored for the header field.

### FieldIdentifier

[Input] It indicates the descriptor field to be set.

### ValuePtr

[Input] It describes a buffer which contains the descriptor information or integer value. The data type depends on the value of FieldIdentifier. If ValuePtr is an integer value, it can be considered to be 8 bytes (SQLLEN), 4 bytes (SQLINTEGER), 2 bytes (SQLSMALLINT) according to the value of FieldIdentifier argument.

## BufferLength

[Input] If FieldIdentifier is the ODBC defined field and ValuePtr points to the string or binary buffer, the argument should be the length of \*ValuePtr. The argument should contain the number of bytes of the string for the string data.

If FieldIdentifier is the ODBC defined field and ValuePtr is an integer, BufferLength is ignored.

If FieldIdentifier is the driver defined field, the application describes the attribute features to the driver manager by setting BufferLength argument. BufferLength can have the following values.

- If ValuePtr is a string buffer pointer, BufferLength is the string length or SQL\_NTS.
- If ValuePtr is a binary buffer pointer, the application stores the result of SQL\_LEN\_BINARY\_ATTR (length) macro in BufferLength. BufferLength stores the negative value.
- If ValuePtr includes the fixed length value, BufferLength is one of SQL\_IS\_INTEGER, SQL\_IS\_UTINYINT, SQL\_IS\_SMALLINT or SQL\_IS\_USMALLINT.

## Returns

SQL\_SUCCESS, SQL\_SUCCESS\_WITH\_INFO, SQL\_ERROR, SQL\_INVALID\_HANDLE

## Diagnosis

SQLSTATE	Error	Description
01000	General warning	It is the driver-specific informational message. (The function returns SQL_SUCCESS_WITH_INFO.)
01S02	Option value changed	The driver does not support the value specified in *ValuePtr (if the value of ValuePtr is an integer.), or *ValuePtr is not valid on the implementation conditions, so the driver replaces it with a similar value. (The function returns SQL_SUCCESS_WITH_INFO.)
07009	Invalid descriptor index	<p>When FieldIdentifier argument is a record field, and RecNumber argument is 0, then DescriptorHandle argument refers to IPD handle.</p> <p>RecNumber argument is smaller than 0, and DescriptorHandle argument refers to ARD or APD.</p> <p>RecNumber argument is bigger than the maximum of the column or parameter supported by the data source, and DescriptorHandle argument refers to APD or ARD.</p> <p>FieldIdentifier argument is SQL_DESC_COUNT, and *ValuePtr argument is smaller than 0.</p> <p>RecNumber argument is equal to 0, and DescriptorHandle argument refers to APD which is implicitly assigned. (This error does not occur f</p>

SQLSTATE	Error	Description
		or the explicitly assigned application descriptor because it is unknown the application descriptor is APD or ARD until the execution time.)
08S01	Communication link failure	Before completing the function processing, the connection between the driver and the data source is failed.
22001	String data, right truncated	FieldIdentifier argument is SQL_DESC_NAME, and BufferLength argument has the value which is bigger than SQL_MAX_IDENTIFIER_LEN.
HY000	General error	It is an error without any specific SQLSTATE.
HY001	Memory allocation error	It is a memory allocation error.
HY010	Function sequence error	<p>The asynchronously executing function is called for DescriptorHandle related to StatementHandle, and this function is still being executed when SQLSetDescField is called.</p> <p>SQLExecute, SQLExecDirect, SQLBulkOperations or SQLSetPos is called on StatementHandle related to DescriptorHandle, and SQL_NEED_DATA is returned.</p> <p>The function is called before all data of the column or parameter are sent at the execution time.</p> <p>The asynchronously executing function is called for connection handle related to DescriptorHandle, and this function is still being executed when SQLSetDescField is called.</p> <p>SQLExecute, SQLExecDirect or SQLMoreResults is called for one of the statement handles related to DescriptorHandle, and SQL_PARAM_DATA_AVAILABLE is returned. The function is called before retrieving data for all streamed parameters.</p>
HY013	Memory management error	The internal memory can not be accessed or the available memory size is small.
HY016	Cannot modify an implementation row descriptor	DescriptorHandle argument is related to IRD, and FieldIdentifier argument is not SQL_DESC_ARRAY_STATUS_PTR nor SQL_DESC_ROWS_PROCESSED_PTR.
HY021	Inconsistent descriptor information	<p>SQL_DESC_TYPE and SQL_DESC_DATETIME_INTERVAL_CODE fields are not a valid ODBC SQL type, valid driver-specific SQL type or a valid ODBC C type.</p> <p>Descriptor information is not consistent when checking the integrity.</p>
HY090	Invalid string or buffer length	<p>*ValuePtr is a string and BufferLength is smaller than 0. (It is not SQL_NTS.)</p> <p>When the driver is the ODBC 2.x driver and the descriptor is ARD and ColumnNumber argument is set to 0, then the value specified in BufferLength is not 4.</p>
		The value specified in FieldIdentifier argument is not the value of OD

SQLSTATE	Error	Description
HY091	Invalid descriptor field identifier	BC defined field or the implementation defined value.  FieldIdentifier argument is invalid for DescriptorHandle argument.  FieldIdentifier argument is the ODBC defined field and it is read-only.
HY092	Invalid attribute/option identifier	The *ValuePtr value is invalid for FieldIdentifier argument.  FieldIdentifier argument is SQL_DESC_UNNAMED, and ValuePtr is SQL_NAMED.
HY105	Invalid parameter type	The value specified in SQL_DESC_PARAMETER_TYPE field is invalid. (Refer to <b>InputOutputType Argument</b> in SQLBindParameter.)
HY117	Connection is suspended due to unknown transaction state. Only disconnect and read-only functions are allowed.	For more information about the suspended state, refer to <b>SQLEndTran</b> .
HYT01	Connection timeout expired	The connection timeout period expired before the response to the data request. The connection timeout period be set via SQL_ATTR_CONNECTION_TIMEOUT of SQLSetConnectAttr.
IM001	Driver does not support this function	The driver does not support the function.

## Description

The application can call SQLSetDescField to set any descriptor field one at a time. One call sets a single field in a single descriptor. The function can be called for setting any field in any descriptor type if the field can be set.



If calling SQLSetDescField fails, the descriptor record contents identified by RecNumber argument is undefined.

Other functions can be called to set multiple descriptor fields with a single call. SQLSetDescRec function can set various fields which affect the data type and the binding column or the parameter buffer. (SQL\_DESC\_TYPE, SQL\_DESC\_DATETIME\_INTERVAL\_CODE, SQL\_DESC\_OCTET\_LENGTH, SQL\_DESC\_PRECISION, SQL\_DESC\_SCALE, SQL\_DESC\_DATA\_PTR, SQL\_DESC\_OCTET\_LENGTH\_PTR, SQL\_DESC\_INDICATOR\_PTR)

SQLBindCol or SQLBindParameter can be used to completely set the columns and parameters. These functions can set a group of descriptor field with a single function call.



SQLSetDescField can be called to change the binding buffer by adding the offset to the binding points. (SQL\_DESC\_DATA\_PTR, SQL\_DESC\_INDICATOR\_PTR, SQL\_DESC\_OCTET\_LENGTH\_PTR) It allows the application change the binding buffers without calling SQLBindCol or SQLBindParameter like as SQL\_DESC\_DATA\_TYPE changes SQL\_DESC\_DATA\_PTR without changing other fields.

If the application calls SQLSetDescField to set any field other than SQL\_DESC\_COUNT or deferred fields (SQL\_DESC\_DATA\_PTR, SQL\_DESC\_OCTET\_LENGTH\_PTR, SQL\_DESC\_INDICATOR\_PTR), then the record binding can be released.

The descriptor header fields is set by calling SQLSetDescField with appropriate FieldIdentifier. Many header fields are the statement attributes, so they can be set by calling SQLSetStmtAttr. It allows the application to set the descriptor field first without obtaining the descriptor handle. When the header field is set by calling SQLSetDescField, RecNumber argument is ignored.

RecNumber which is 0 is used to set the bookmark field.



The statement attribute SQL\_ATTR\_USE\_BOOKMARKS should be set before calling SQLSetDescField to set the bookmark fields. It is not necessary but is strongly recommended.

## Order of Setting Descriptor Fields

When setting the descriptor fields by calling SQLSetDescField, the application should follow the specified order.

1. The application should preferentially set SQL\_DESC\_TYPE, SQL\_DESC\_CONCISE\_TYPE or SQL\_DESC\_DATETIME\_INTERVAL\_CODE field.
2. After one of these fields is set, the application can set the attributes of the data types and the driver can set the data type setting fields to appropriate default values for the data types. Automatic default setting of the type attribute fields ensures that the descriptor is always ready to use after the application specifies the data types. When the application explicitly sets the data type attribute, the default attribute will be overwritten.
3. After setting one of the fields in step 1 and setting the data type attribute, the application can set SQL\_DESC\_DATA\_PTR. It prompts the consistency check of the descriptor fields. If the application sets SQL\_DESC\_DATA\_PTR field after changing the data type or attribute, the driver sets SQL\_DESC\_DATA\_PTR to a NULL pointer and releases the record binding. It forces the application to sequentially complete the appropriate procedures before the descriptor record is able to be used.

## Initializing Descriptor Field

When a descriptor is allocated, the descriptor fields can be initialized to the default value or it can be initialized to the value which does not have default or is not defined in the descriptor type. The following table describes the initialization of each field of each descriptor type. D refers to the initialization field with th

e default value. ND refers to the initialization field without default. The number refers that the default value of field is a number. The table also indicates whether the field is read/write or read-only.

The field of IRD can have the default value after the statement is prepared or executed and IRD is generated, and it is not when the statement handle or descriptor is allocated. Any access attempt to the IRD field returns an error until IRD is generated.

Some descriptor fields are defined for one or more, but not for all descriptor types (ARD, IRD, APD, IPD). If a field is not defined in the descriptor type, it is not required for the function which uses the descriptor.

The accessible fields by SQLGetDescField are not necessarily possible to be set with SQLSetDescField. The fields which can be set by SQLSetDescField are listed in the following table.

The following table describes the initialization of the header fields.

Header field name	Format	R/W	Default value
SQL_DESC_ALLOC_TYPE	SQLSMALLINT	ARD: R APD: R IRD: R IPD: R	ARD: SQL_DESC_ALLOC_AUTO for implicit or SQL_DESC_ALLOC_USER for explicit APD: SQL_DESC_ALLOC_AUTO for implicit or SQL_DESC_ALLOC_USER for explicit IRD: SQL_DESC_ALLOC_AUTO IPD: SQL_DESC_ALLOC_AUTO
SQL_DESC_ARRAY_SIZE	SQLULEN	ARD: R/W APD: R/W IRD: Unused IPD: Unused	ARD:[1] APD:[1] IRD: Unused IPD: Unused
SQL_DESC_ARRAY_STATUS_PTR	SQLUSMALLINT*	ARD: R/W APD: R/W IRD: R/W IPD: R/W	ARD: Null ptr APD: Null ptr IRD: Null ptr IPD: Null ptr
SQL_DESC_BIND_OFFSET_PTR	SQLLEN*	ARD: R/W APD: R/W IRD: Unused IPD: Unused	ARD: Null ptr APD: Null ptr IRD: Unused IPD: Unused
SQL_DESC_BIND_TYPE	SQLINTEGER	ARD: R/W APD: R/W IRD: Unused IPD: Unused	ARD: SQL_BIND_BY_COLUMN APD: SQL_BIND_BY_COLUMN IRD: Unused IPD: Unused
SQL_DESC_COUNT	SQLSMALLINT	ARD: R/W APD: R/W IRD: R IPD: R/W	ARD: 0 APD: 0 IRD: D IPD: 0
SQL_DESC_ROWS_P	SQLULEN	ARD: Unused APD: Unused	ARD: Unused APD: Unused

Header field name	Format	R/W	Default value
ROCESSED_PTR	*	RD: R/W IPD: R/W	IRD: Null ptr IPD: Null ptr

[1]Fields are defined only when IPD is automatically generated by the driver. Otherwise, they are not defined. When the application tries to set the fields, SQLSTATE HY091 (Invalid descriptor field identifier) will be returned.

The following table describes the initialization of the record fields.

Record field name	Format	R/W	Default value
SQL_DESC_AUTO_UNIQUE_VALUE	SQLINTEGER	ARD: Unused APD: Unused IRD: R IPD: Unused	ARD: Unused APD: Unused IRD: D IPD: Unused
SQL_DESC_BASE_COLUMN_NAME	SQLCHAR *	ARD: Unused APD: Unused IRD: R IPD: Unused	ARD: Unused APD: Unused IRD: D IPD: Unused
SQL_DESC_BASE_TABLE_NAME	SQLCHAR *	ARD: Unused APD: Unused IRD: R IPD: Unused	ARD: Unused APD: Unused IRD: D IPD: Unused
SQL_DESC_CASE_SENSITIVE	SQLINTEGER	ARD: Unused APD: Unused IRD: R IPD: R	ARD: Unused APD: Unused IRD: D IPD: D[1]
SQL_DESC_CATALOG_NAME	SQLCHAR *	ARD: Unused APD: Unused IRD: R IPD: Unused	ARD: Unused APD: Unused IRD: D IPD: Unused
SQL_DESC_CHAR_LENGTH_UNITS	SQLSMALLINT	ARD: Unused APD: Unused IRD: Unused IPD: W	ARD: Unused APD: Unused IRD: ND IPD: Unused
SQL_DESC_CONCISE_TYPE	SQLSMALLINT	ARD: R/W APD: R/W IRD: R IPD: R/W	ARD: SQL_C_ DEFAULT APD: SQL_C_ DEFAULT IRD: D IPD: ND
SQL_DESC_DATA_PTR	SQLPOINTER	ARD: R/W APD: R/W IRD: Unused IPD: Unused	ARD: Null ptr APD: Null ptr IRD: Unused IPD: Unused[2]

Record field name	Format	R/W	Default value
SQL_DESC_DATETIME_INTERVAL_CODE	SQLSMALLINT	ARD: R/W APD: R/W IRD: R IPD: R/W	ARD: ND APD: ND IRD: D IPD: ND
SQL_DESC_DATETIME_INTERVAL_PRECISION	SQLINTEGER	ARD: R/W APD: R/W IRD: R IPD: R/W	ARD: ND APD: ND IRD: D IPD: ND
SQL_DESC_DISPLAY_SIZE	SQLLEN	ARD: Unused APD: Unused IRD: R IPD: Unused	ARD: Unused APD: Unused IRD: D IPD: Unused
SQL_DESC_FIXED_PREC_SCALE	SQLSMALLINT	ARD: Unused APD: Unused IRD: R IPD: R	ARD: Unused APD: Unused IRD: D IPD: D[1]
SQL_DESC_INDICATOR_PTR	SQLLEN *	ARD: R/W APD: R/W IRD: Unused IPD: Unused	ARD: Null ptr APD: Null ptr IRD: Unused IPD: Unused
SQL_DESC_LABEL	SQLCHAR *	ARD: Unused APD: Unused IRD: R IPD: Unused	ARD: Unused APD: Unused IRD: D IPD: Unused
SQL_DESC_LENGTH	SQLULEN	ARD: R/W APD: R/W IRD: R IPD: R/W	ARD: ND APD: ND IRD: D IPD: ND
SQL_DESC_LITERAL_PREFIX	SQLCHAR *	ARD: R/W APD: R/W IRD: R IPD: R/W	ARD: Unused APD: Unused IRD: D IPD: Unused
SQL_DESC_LITERAL_SUFFIX	SQLCHAR *	ARD: Unused APD: Unused IRD: R IPD: Unused	ARD: Unused APD: Unused IRD: D IPD: Unused
SQL_DESC_LOCAL_TYPE_NAME	SQLCHAR *	ARD: Unused APD: Unused IRD: R IPD: R	ARD: Unused APD: Unused IRD: D IPD: D[1]
SQL_DESC_NAME	SQLCHAR *	ARD: Unused APD: Unused IRD: R	ARD: Unused APD: Unused IRD: D

Record field name	Format	R/W	Default value
		IPD: R/W	IPD: D[1]
SQL_DESC_NULLABLE	SQLSMALLINT	ARD: Unused APD: Unused IRD: R IPD: R	ARD: ND APD: ND IRD: D IPD: ND
SQL_DESC_NUM_PREC_RADIX	SQLINTEGER	ARD: R/W APD: R/W IRD: R IPD: R/W	ARD: ND APD: ND IRD: D IPD: ND
SQL_DESC_OCTET_LENGTH	SQLLEN	ARD: R/W APD: R/W IRD: R IPD: R/W	ARD: ND APD: ND IRD: D IPD: ND
SQL_DESC_OCTET_LENGTH_PTR	SQLLEN *	ARD: R/W APD: R/W IRD: Unused IPD: Unused	ARD: Null ptr APD: Null ptr IRD: Unused IPD: Unused
SQL_DESC_PARAMETER_TYPE	SQLSMALLINT	ARD: Unused APD: Unused IRD: Unused IPD: R/W	ARD: Unused APD: Unused IRD: Unused IPD: D=SQL_PARAM_INPUT
SQL_DESC_PRECISION	SQLSMALLINT	ARD: R/W APD: R/W IRD: R IPD: R/W	ARD: ND APD: ND IRD: D IPD: ND
SQL_DESC_ROWVER	SQLSMALLINT	ARD: Unused APD: Unused IRD: R IPD: R	ARD: Unused APD: Unused IRD: ND IPD: ND
SQL_DESC_SCALE	SQLSMALLINT	ARD: R/W APD: R/W IRD: R IPD: R/W	ARD: ND APD: ND IRD: D IPD: ND
SQL_DESC_SCHEMA_NAME	SQLCHAR *	ARD: Unused APD: Unused IRD: R IPD: Unused	ARD: Unused APD: Unused IRD: D IPD: Unused
SQL_DESC_SEARCHABLE	SQLSMALLINT	ARD: Unused APD: Unused IRD: R IPD: Unused	ARD: Unused APD: Unused IRD: D IPD: Unused
		ARD: Unused	ARD: Unused

Record field name	Format	R/W	Default value
SQL_DESC_TABLE_NAME	SQLCHAR *	APD: Unused IRD: R IPD: Unused	APD: Unused IRD: D IPD: Unused
SQL_DESC_TYPE	SQLSMALLINT	ARD: R/W APD: R/W IRD: R IPD: R/W	ARD: SQL_C_DEFAULT APD: SQL_C_DEFAULT IRD: D IPD: ND
SQL_DESC_TYPE_NAME	SQLCHAR *	ARD: Unused APD: Unused IRD: R IPD: R	ARD: Unused APD: Unused IRD: D IPD: D <sup>[1]</sup>
SQL_DESC_UNNAMED	SQLSMALLINT	ARD: Unused APD: Unused IRD: R IPD: R/W	ARD: ND APD: ND IRD: D IPD: ND
SQL_DESC_UNSIGNED	SQLSMALLINT	ARD: Unused APD: Unused IRD: R IPD: R	ARD: Unused APD: Unused IRD: D IPD: D <sup>[1]</sup>
SQL_DESC_UPDATABLE	SQLSMALLINT	ARD: Unused APD: Unused IRD: R IPD: Unused	ARD: Unused APD: Unused IRD: D IPD: Unused

<sup>[1]</sup>Fields are defined only when IPD is automatically generated by the driver. Otherwise, they are not defined. When the application tries to set the fields, SQLSTATE HY091 (Invalid descriptor field identifier) will be returned.

<sup>[2]</sup>SQL\_DESC\_DATA\_PTR field of IPD is set to force check the consistency. In the subsequent SQLGetDescField or SQLGetDescRec call, the driver does not need to return the value which SQL\_DESC\_DATA\_PTR is set to.

## FieldIdentifier Argument

FieldIdentifier argument indicates the descriptor field to be set. Descriptor consists of a descriptor header and a header field described in the following header field. Descriptor records consists of the record fields described in the following header field.

## Header Field

Each descriptor consists of the following fields.

**SQL\_DESC\_ALLOC\_TYPE[All] (read-only)**

This read-only SQLSMALLINT header field specifies whether the descriptor is automatically allocated by the driver or explicitly allocated by the application. The application can obtain this field but cannot update it. The field is set to SQL\_DESC\_ALLOC\_AUTO by the driver when the descriptor is automatically allocated by the driver.

**SQL\_DESC\_ARRAY\_SIZE[Application descriptors]**

This SQLLEN header field in ARD specifies the number of rows in a row set. This is the number of rows to be returned by calling SQLFetch, SQLFetchScroll, or to be operated by calling SQLBulkOperations or SQLSetPos.

The header field in APD, SQLULEN, specifies the number of parameters.

The default value of the field is 1. If SQL\_DESC\_ARRAY\_SIZE is bigger than 1, SQL\_DESC\_DATA\_PTR, SQL\_DESC\_INDICATOR\_PTR and SQL\_DESC\_OCTET\_LENGTH\_PTR of APD or ARD points to an array. The constant of each array is equal to the field value.

The field in ARD can be set by calling SQLSetStmtAttr with SQL\_ATTR\_ROW\_ARRAY\_SIZE attribute. The field in APD can be set by calling SQLSetStmtAttr with SQL\_ATTR\_PARAMSET\_SIZE attribute.

**SQL\_DESC\_ARRAY\_STATUS\_PTR[All]**

SQLSMALLINT\* header field for each descriptor type points to an array of SQLUSMALLINT value. The arrays are named such as row status array (IRD), parameter status array (IPD), row operation array (ARD), parameter operation array (APD).

The header field in IRD points to the row status array which includes the status value after calling SQLBulkOperations, SQLFetch, SQLFetchScroll, or SQLSetPos. The application allocates the SQLUSMALLINT array and makes the field to point to the array. The field is a NULL pointer by default. The driver will create an array if SQL\_DESC\_ARRAY\_STATUS\_PTR field is not set to a NULL pointer.



If the application sets the elements of the row status array pointed by SQL\_DESC\_ARRAY\_STATUS\_PTR of IRD, the driver operation is not defined.

The array is initially populated by calling SQLBulkOperations, SQLFetch, SQLFetchScroll or SQLSetPos. If the call does not return SQL\_SUCCESS or SQL\_SUCCESS\_WITH\_INFO, the content of array pointed by the field is undefined. Elements of the array may contain the following values.

- SQL\_ROW\_SUCCESS: The row is successfully fetched, and it is not changed since the last fetch.
- SQL\_ROW\_SUCCESS\_WITH\_INFO: The row is successfully fetched, and it is not changed since the last fetch, but the warning for the row is returned.
- SQL\_ROW\_ERROR: An error occurs while the row is fetched.
- SQL\_ROW\_UPDATED: The row is successfully fetched, and it is updated since the last fetch. If the row is fetched again, the state is SQL\_ROW\_SUCCESS.
- SQL\_ROW\_DELETED: The row is deleted since the last fetch.
- SQL\_ROW\_ADDED: The row is inserted by SQLBulkOperations. If the row is fetched again, the state is

SQL\_ROW\_SUCCESS.

- SQL\_ROW\_NOROW: The row set is overlapped with the end of the result set. And any row is not returned corresponding to elements of the row status array.

This field of IRD can be set by calling `SQLSetStmtAttr` with `SQL_ATTR_ROW_STATUS_PTR` attribute.

`SQL_DESC_ARRAY_STATUS_PTR` field of IRD is valid after `SQL_SUCCESS` or `SQL_SUCCESS_WITH_INFO` is returned. If the return code is not one of these, anything pointed by `SQL_DESC_ROWS_PROCESSED_PTR` is not defined.

This header field in IPD indicates the parameter status array which includes status information of each parameter after calling `SQLExecute` or `SQLExecDirect`. If `SQLExecute` or `SQLExecDirect` is called and `SQL_SUCCESS` or `SQL_SUCCESS_WITH_INFO` is not returned, then the content of the array which is pointed by the field is not defined. The application allocates `SQLUSMALLINT` array, the field should point to the array. The driver will create an array if `SQL_DESC_ARRAY_STATUS_PTR` field is not set to a NULL pointer. Elements in the array contain the following values.

- `SQL_PARAM_SUCCESS`: The SQL statement is successfully executed for the parameter set.
- `SQL_PARAM_SUCCESS_WITH_INFO`: The SQL statement is successfully executed for the parameter set, but there is a warning information available to the diagnostic data structure.
- `SQL_PARAM_ERROR`: An error occurs to process the parameter set. The additional error information is in the diagnostic data structure.
- `SQL_PARAM_UNUSED`: This parameter is not used because some previous parameter set causes an error which aborts further processing, or `SQL_PARAM_IGNORE` is set to the parameter set in the array specified by `SQL_DESC_ARRAY_STATUS_PTR` field of APD.
- `SQL_PARAM_DIAG_UNAVAILABLE`: The diagnostic information can not be used. For example, the driver does not generate the level of error information by treating the array of the parameter as single one.

This field in IPD can be set by calling `SQLSetStmtAttr` with `SQL_ATTR_PARAM_STATUS_PTR` attribute.

In ARD, this field points to the row operation array for the value set by the application to determine whether the row is ignored in `SQLSetPos` operation. Elements of the array may contain the following values.

- `SQL_ROW_PROCEED`: The row is included in bulk operation using `SQLSetPos`. (This setting does not guarantee that the operation occurs on the row. If the row has `SQL_ROW_ERROR` state of IRD row status array, the driver will not be able to perform the operation for the row.)
- `SQL_ROW_IGNORE`: The row is excluded from the bulk operation using `SQLSetPos`.

If an element in the array is not set, all rows are included in the bulk operation. If the value of `SQL_DESC_ARRAY_STATUS_PTR` field of ARD is a NULL pointer, all rows are included in the bulk operation. It means that the pointer points to a valid array and all elements of the array are `SQL_ROW_PROCEED`. If all elements in an array are set to `SQL_ROW_IGNORE`, the values in the row status array are not updated for the ignored row.



This field in ARD also can be set by calling `SQLSetStmtAttr` with `SQL_ATTR_ROW_OPERATION_PTR` attribute.

This header field in ARD indicates the parameter operation array of the values which can be set by the application to determine whether the parameter set is ignored when `SQLExecute` or `SQLExecDirect` is called. Elements of the array may contain the following values.

- `SQL_PARAM_PROCEED`: The parameter set is included in `SQLExecute` or `SQLExecDirect` call.
- `SQL_PARAM_IGNORE`: The parameter set is not included in `SQLExecute` or `SQLExecDirect` call.

If an element in the array is not set, all parameter sets of the array are used to call `SQLExecute` or `SQLExecDirect`. If the value of `SQL_DESC_ARRAY_STATUS_PTR` field of APD is a NULL pointer, all parameter sets are used. It is interpreted as if the pointer points to the valid array and all elements of the array are `SQL_PARAM_PROCEED`.

This field in APD can be set by calling `SQLSetStmtAttr` with `SQL_ATTR_PARAM_OPERATION_PTR` attribute.

#### **SQL\_DESC\_BIND\_OFFSET\_PTR[Application descriptors]**

This `SQLLEN*` header field indicates the offset of the binding. It is set as a NULL pointer by default. If the field is not a NULL pointer, the driver dereferences the pointer and adds the dereferenced value to each of the deferred fields which has a non-null value in the descriptor record (`SQL_DESC_DATA_PTR`, `SQL_DESC_INDICATOR_PTR` and `SQL_DESC_OCTET_LENGTH_PTR`), and uses a new pointer value when binding.

The binding offset is always directly added to `SQL_DESC_DATA_PTR`, `SQL_DESC_INDICATOR_PTR` and `SQL_DESC_OCTET_LENGTH_PTR` fields. If the offset is changed to the other value, the new value is continuously and directly added as each descriptor field value.

The field is a deferred field. The field is not used at the time to be set and it is used later by the driver when the addresses of the data buffers are needed to be checked.

This field in ARD can be set by calling `SQLSetStmtAttr` with `SQL_ATTR_ROW_BIND_OFFSET_PTR` attribute. This field in APD can be set by calling `SQLSetStmtAttr` with `SQL_ATTR_PARAM_BIND_OFFSET_PTR` attribute.

For more information, refer to [SQLFetchScroll](#) or [SQLBindParameter](#).

#### **SQL\_DESC\_BIND\_TYPE[Application descriptors]**

This `SQLINTEGER` header field is used to set the binding direction.

This field in ARD specifies the binding direction when `SQLFetchScroll` or `SQLFetch` is called in the related statement handle.

This field is set to `SQL_BIND_BY_COLUMN`(default) to select the column-wise binding for the column.

This field in ARD can be set by calling `SQLSetStmtAttr` with `SQL_ATTR_ROW_BIND_TYPE` attribute.

This field specifies the binding direction to be used in the Dynamic parameters.

This field is set to SQL\_BIND\_BY\_COLUMN(default) to select the column-wise binding for the parameter.

This field can be set by calling SQLSetStmtAttr with SQL\_ATTR\_PARAM\_BIND\_TYPE attribute.

### SQL\_DESC\_COUNT[All]

This header field of SQLSMALLINT specifies a 1-based index of the best record including the data. When the driver sets the data structure to the descriptor, SQL\_DESC\_COUNT should be set to display how many of the important records. The application does not need to specify the amount of space reserved for the records when allocating instances of the data structure. As like the application specifies the contents of the records, the driver performs the requested operation to ensure that the descriptor handle indicates the data structure of sufficient size.

SQL\_DESC\_COUNT is not the number of all bound data columns or the number of parameters but is the number of highest-numbered records. If the binding of the highest-numbered column or parameter is released, SQL\_DESC\_COUNT is changed to the number of the next highest-numbered columns or parameters. If the binding of column or parameter which is smaller than the number of highest-numbered columns or parameters is released (when TargetValuePtr argument is set to a NULL pointer and SQLBindCol is called, or when ParameterValuePtr argument is set to a NULL pointer and SQLBindParameter is called.) SQL\_DESC\_COUNT is not changed. If columns or parameters to be added are bound with the number which is bigger than the highest-numbered record including the data, the driver automatically increases the value of SQL\_DESC\_COUNT field. If the binding for all columns are released by calling SQLFreeStmt with SQL\_UNBIND option, SQL\_DESC\_COUNT field in ARD or IRD is set to 0. If SQLFreeStmt is called as SQL\_RESET\_PARAMS option, SQL\_DESC\_COUNT fields in APD and IPD are set to 0.

SQL\_DESC\_COUNT value can be explicitly set by calling SQLSetDescField in the application. If SQL\_DESC\_COUNT value is clearly reduced, all records having a bigger value than the new SQL\_DESC\_COUNT value are effectively deleted. If the value of SQL\_DESC\_COUNT field of ARD is clearly set to 0, all buffers are released except for the bound bookmark column. The number of records in the field of ARD do not include the bound bookmark column. The only way to release the bound bookmark column is set SQL\_DESC\_DATA\_PTR to a NULL pointer.

### SQL\_DESC\_ROWS\_PROCESSED\_PTR[Implementation descriptors]

This SQLULEN\* header field in IRD points to the buffers which include the number of rows fetched after SQLFetch or SQLFetchScroll is called, or the number of rows and errors affected in the bulk operation performed by calling SQLBulkOperations or SQLSetPos.

This SQLINTEGER\* header field of IPD points to the buffers which include the number of parameter set and errors processed. If it is a NULL pointer, it will not return the number.

SQL\_DESC\_ROWS\_PROCESSED\_PTR is valid only after SQL\_SUCCESS or SQL\_SUCCESS\_WITH\_INFO has been returned after calling SQLFetch or SQLFetchScroll (for an IRD field) or SQLExecute, SQLExecDirect, or SQLParamData (for an IPD field). If the functions does not return SQL\_SUCCESS or S

QL\_SUCCESS\_WITH\_INFO, the buffer content is not defined and the buffer value is set to 0 until SQL\_NO\_DATA is returned.

This field in ARD can be set by calling SQLSetStmtAttr with SQL\_ATTR\_ROWS\_FETCHED\_PTR attribute. This field in APD can be set by calling SQLSetStmtAttr with SQL\_ATTR\_PARAMS\_PROCESSED\_PTR attribute.

The buffer which is pointed by this field is allocated by the application. It is the deferred output buffer set by the driver. A NULL pointer is set by default.

## Record Field

Each descriptor includes at least one record consisting of the fields which defines one of the columns of data or dynamic parameters depending on the descriptor type. Each record is a complete specification of a single column or parameter.

### SQL\_DESC\_AUTO\_UNIQUE\_VALUE[IRDs] (read-only)

This read-only SQLINTEGER record field has SQL\_TRUE if it is auto-increment column. Otherwise, it has the SQL\_FALSE. The field is read-only but it does not necessarily need to be read-only, if it is auto-increment column.

### SQL\_DESC\_BASE\_COLUMN\_NAME[IRDs] (read-only)

This read-only SQLCHAR\* record field includes the base column name of the result set column. If the base column name does not exist, the field includes an empty string.

### SQL\_DESC\_TABLE\_NAME[IRDs] (read-only)

This read-only SQLCHAR\* record field includes the base table name of the result set column. If the base table name can not be defined or not available, the field includes an empty string.

### SQL\_DESC\_CASE\_SENSITIVE[Implementation descriptors] (read-only)

This read-only SQLINTEGER record field is SQL\_TRUE if columns or parameters is case-sensitive when sorting and comparing. It is SQL\_FALSE if it is case-insensitive or the column with non-character.

### SQL\_DESC\_CATALOG\_NAME[IRDs] (read-only)

This read-only SQLCHAR\* record field includes the catalog of the base table including the column. If the column is a part of an expression or view, the return value depends on the driver. If the data source does not support or the catalog can not be determined, the field includes an empty string.

### SQL\_DESC\_CHAR\_LENGTH\_UNITS[IPD]

This SQLSMALLINT record field describes the unit of SQL\_DESC\_LENGTH. (SQL\_CLU\_NONE/ SQL\_CHARACTER/ SQL\_OCTETS)

### SQL\_DESC\_CONCISE\_TYPE[AII]

This SQLSMALLINT header field specifies a simplified form for all data types including datetime and interval data types.

The values of SQL\_DESC\_CONCISE\_TYPE, SQL\_DESC\_TYPE and SQL\_DESC\_DATETIME\_INTERVAL\_CODE fields are interdependent. If time is set in a field, it should be set in others fields as well. SQL

\_DESC\_CONCISE\_TYPE can be set by calling SQLBindCol, SQLBindParameter or SQLSetDescField. SQL\_DESC\_TYPE can be set by calling SQLSetDescField or SQLSetDescRec.

If SQL\_DESC\_CONCISE\_TYPE is set to a concise data type except for the interval or datetime data type, SQL\_DESC\_TYPE field is set to the same value and SQL\_DESC\_DATETIME\_INTERVAL\_CODE field is set to 0.

If SQL\_DESC\_CONCISE\_TYPE is set to a concise interval or datetime data type, SQL\_DESC\_TYPE field is set to a detailed data type (SQL\_DATETIME or SQL\_INTERVAL), and SQL\_DESC\_DATETIME\_INTERVAL\_CODE field is set to the appropriate sub code.

#### SQL\_DESC\_DATETIME\_INTERVAL\_CODE[All]

This SQLSMALLINT record field includes the sub code for specifying datetime or interval data type if SQL\_DESC\_TYPE field is SQL\_DATETIME or SQL\_INTERVAL. It is same for both SQL and C. The code includes the data type name with CODE which is replaced with TYPE or C\_TYPE of datetime types, INTERVAL or C\_INTERVAL of interval types.

If SQL\_DESC\_TYPE and SQL\_DESC\_CONCISE\_TYPE of the application descriptor are set to SQL\_C\_DEFAULT and the descriptor is not related to the statement handle, the content of SQL\_DESC\_DATETIME\_INTERVAL\_CODE is not defined.

This field can set the datetime data types which is listed in the following table.

Datetime type	DATETIME_INTERVAL_CODE
SQL_TYPE_DATE/ SQL_C_TYPE_DATE	SQL_CODE_DATE
SQL_TYPE_TIME/ SQL_C_TYPE_TIME	SQL_CODE_TIME
SQL_TYPE_TIME_WITH_TIMEZONE/ SQL_C_TYPE_TIME_WITH_TIMEZONE	SQL_CODE_TIME_WITH_TIMEZONE
SQL_TYPE_TIMESTAMP/ SQL_C_TYPE_TIMESTAMP	SQL_CODE_TIMESTAMP
SQL_TYPE_TIMESTAMP_WITH_TIMEZONE/ SQL_C_TYPE_TIMESTAMP_WITH_TIMEZONE	SQL_CODE_TIMESTAMP_WITH_TIMEZONE

This field can set the interval data types which is listed in the following table.

Interval type	DATETIME_INTERVAL_CODE
SQL_INTERVAL_DAY/ SQL_C_INTERVAL_DAY	SQL_CODE_DAY
SQL_INTERVAL_DAY_TO_HOUR/ SQL_C_INTERVAL_DAY_TO_HOUR	SQL_CODE_DAY_TO_HOUR
SQL_INTERVAL_DAY_TO_MINUTE/ SQL_C_INTERVAL_DAY_TO_MINUTE	SQL_CODE_DAY_TO_MINUTE
SQL_INTERVAL_DAY_TO_SECOND/ SQL_C_INTERVAL_DAY_TO_SECOND	SQL_CODE_DAY_TO_SECOND

Interval type	DATETIME_INTERVAL_CODE
SQL_INTERVAL_HOUR/ SQL_C_INTERVAL_HOUR	SQL_CODE_HOUR
SQL_INTERVAL_HOUR_TO_MINUTE/ SQL_C_INTERVAL_HOUR_TO_MINUTE	SQL_CODE_HOUR_TO_MINUTE
SQL_INTERVAL_HOUR_TO_SECOND/ SQL_C_INTERVAL_HOUR_TO_SECOND	SQL_CODE_HOUR_TO_SECOND
SQL_INTERVAL_MINUTE/ SQL_C_INTERVAL_MINUTE	SQL_CODE_MINUTE
SQL_INTERVAL_MINUTE_TO_SECOND/ SQL_C_INTERVAL_MINUTE_TO_SECOND	SQL_CODE_MINUTE_TO_SECOND
SQL_INTERVAL_MONTH/ SQL_C_INTERVAL_MONTH	SQL_CODE_MONTH
SQL_INTERVAL_SECOND/ SQL_C_INTERVAL_SECOND	SQL_CODE_SECOND
SQL_INTERVAL_YEAR/ SQL_C_INTERVAL_YEAR	SQL_CODE_YEAR
SQL_INTERVAL_YEAR_TO_MONTH/ SQL_C_INTERVAL_YEAR_TO_MONTH	SQL_CODE_YEAR_TO_MONTH

**SQL\_DESC\_DATETIME\_INTERVAL\_PRECISION[All]**

This SQLINTEGER record field includes interval leading precision if SQL\_DESC\_TYPE field is SQL\_INTERVAL. When SQL\_DESC\_DATETIME\_INTERVAL\_CODE field is set to interval data type, the field is set to the default interval leading precision.

**SQL\_DESC\_DISPLAY\_SIZE[IRDs] (read-only)**

This read-only SQLINTEGER record field includes the maximum number of characters required to display the data from the column.

**SQL\_DESC\_FIXED\_PREC\_SCALE[Implementation descriptors] (read-only)**

This read-only SQLSMALLINT record field is set to SQL\_TRUE if the column is an exact numeric column and it has the non-zero scale and the fixed precision. Otherwise, it is set to SQL\_FALSE.

**SQL\_DESC\_INDICATOR\_PTR[Application descriptors]**

This SQLLEN\* record field in ARD indicates the indicator variable. The variable contains SQL\_NULL\_DATE if the column value is NULL. In APD, the indicator variable is set to SQL\_NULL\_DATA to specify a dynamic argument to NULL. Otherwise, the variable is 0.

If SQL\_DESC\_INDICATOR\_PTR field of ARD is a NULL pointer, the driver is prevented from returning the information about whether the column is NULL. If the column is NULL and SQL\_DESC\_INDICATOR\_PTR is a NULL pointer, SQLSTATE 22002(Indicator variable required but not supplied) is returned when the driver tries to create a buffer after calling SQLFetch or SQLFetchScroll. If SQLFetch or SQLFetchScroll call does not return SQL\_SUCCESS or SQL\_SUCCESS\_WITH\_INFO, the buffer content is not defined.

SQL\_DESC\_INDICATOR\_PTR field defines whether to set the field indicated by SQL\_DESC\_OCTET\_LENGTH\_PTR. If the column data value is NULL, the driver sets the indicator variable to SQL\_NULL\_DATA. The field indicated by SQL\_DESC\_OCTET\_LENGTH\_PTR is not set at that time. If the NULL value is not encountered during the fetch, the buffer indicated by SQL\_DESC\_INDICATOR\_PTR is set to 0, and the buffer indicated by SQL\_DESC\_OCTET\_LENGTH\_PTR is set to the data length.

If SQL\_DESC\_INDICATOR\_PTR field of APD is a NULL pointer, the application can not use the descriptor record to specify the arguments as NULL.

It is a deferred field. The field is not used when it is set but it is used when the driver describes the possibility of NULL (for ARD) or determines the possibility of NULL (for APD).

#### **SQL\_DESC\_LABEL[IRDs] (read-only)**

This read-only SQLCHAR\* record field includes the column label or cover. If the column does not have its label, the variable includes the column name. If the column is not named or can not use its label, the variable includes an empty string.

#### **SQL\_DESC\_LENGTH[All]**

This SQLULEN record field is a maximum length or actual length of the string, or binary data type in bytes. It is the actual length of fixed length data types or the maximum length of variable-length data types. The value always excludes NULL termination character at the end of the string. If the data type of the value is SQL\_TYPE\_DATE, SQL\_TYPE\_TIME, SQL\_TYPE\_TIMESTAMP or SQL interval data type, the field has the length of characters when the datetime or interval value is represented by string again.

This field value may be different from the value of the length defined in ODBC 2.x.

#### **SQL\_DESC\_LITERAL\_PREFIX[IRDs] (read-only)**

This read-only SQLCHAR\* record field includes the characters or character which the driver recognizes as a suffix. The variable includes an empty string for the data type to which the character suffix is not applicable.

#### **SQL\_DESC\_LOCAL\_TYPE\_NAME[Implementation descriptors] (read-only)**

This read-only SQLCHAR\* record field includes a localized name for the data type which may be different from the regular name of the data type. If the localized name does not exist, then an empty string is returned. The field is only for the display purpose.

#### **SQL\_DESC\_NAME[Implementation descriptor]**

This SQLCHAR\* record field includes the alias of the field in the row descriptor. If the alias of a column is not applied, the column name is returned. In either case, the driver sets SQL\_DESC\_UNNAMED field to SQL\_NAMED when setting SQL\_DESC\_NAME. If column name or its alias does not exist, then the driver returns an empty string of SQL\_DESC\_NAME field and sets SQL\_DESC\_UNNAMED field to SQL\_UNNAMED.

The application can set SQL\_DESC\_NAME field of IPD to a parameter name or alias to specify stored procedure parameters by name. SQL\_DESC\_NAME field of IRD is a read-only field. If the application tries to set the field, SQLSTATE HY091 (Invalid descriptor field identifier) is returned.

For IPD, if the driver does not support the named parameters, the field is not defined. If the driver supports the named parameters and it can explain the parameters, the parameter name is returned in this field.

#### **SQL\_DESC\_NULLABLE[Implementation descriptors] (read-only)**

For IRD, if the column of this read-only SQLSMALLINT record field is allowed to be NULL, it is SQL\_DESC\_NULLABLE. If NULL is not allowed, it is SQL\_NO\_NULLS. If the column is unknown whether or not to allow NULL, it is SQL\_NULLABLE\_UNKNOWN. The field exists particularly for a column in the result set.

For IPD, this field is always set to SQL\_DESC\_NULLABLE because the dynamic parameters are always allowed to have NULL and can not be set by the application.

#### **SQL\_DESC\_NUM\_PREC\_RADIX[All]**

This SQLINTEGER record field has the value of 2 when SQL\_DESC\_TYPE field is the approximate numeric data type. Because SQL\_DESC\_PRECISION field includes the number of the bits. The field has the value of 10 when SQL\_DESC\_TYPE field has the exact numeric data type because SQL\_DESC\_PRECISION field includes the number of decimal places. The field sets 0 for a non-numeric data type.

#### **SQL\_DESC\_OCTET\_LENGTH[All]**

This SQLLEN record field includes the length in bytes of a string or binary data type. For the fixed length character or binary data type, it is the actual length (in bytes). For the variable length character or binary data type, it is the maximum length (in bytes). The value does not include a space of null-termination character for the implementation descriptor but it includes a space of null-termination character for the application descriptor. For the application data, the field contains the buffer size. For APD, the field is defined only for the output or input/output parameters.

#### **SQL\_DESC\_OCTET\_LENGTH\_PTR[Application descriptors]**

This SQLLEN\* record field points to a variable which includes the total length in bytes of the dynamic argument (for parameter descriptor) or the bound column value (for row descriptors).

For APD, the value is ignored for all argument except for the string and binary. If the field is SQL\_NULLS, the dynamic argument should be null-terminated. The application sets the variable which includes the result of SQL\_DATA\_AT\_EXEC or SQL\_LEN\_DATA\_AT\_EXEC macro at execution time in the record field of APD to indicate that it is a bound parameter to be data-at-execution parameter. If one or more of such fields exist, SQL\_DESC\_DATA\_PTR can be set to a value identifying the parameter to help the application determine which parameter is being requested.

If OCTET\_LENGTH\_PTR field of ARD is a NULL pointer, the driver does not return the column length information. If SQL\_DESC\_OCTET\_LENGTH\_PTR of APD is a NULL pointer, the driver assumes that the string and binary values are null-terminated. (Binary values should not be null-terminated, but a length should be given to avoid data interruption.)

If SQLFetch or SQLFetchScroll which fills the buffer pointed by the field does not return SQL\_SUCCESS or SQL\_SUCCESS\_WITH\_INFO, the buffer content is not defined. It is the deferred field. The field is not immediately used, but it is used later when the driver indicates or determines the octet length of the data.

**SQL\_DESC\_PARAMETER\_TYPE[IRDs]**

This SQLSMALLINT record field is set to SQL\_PARAM\_INPUT for the input parameters, to SQL\_PARAM\_INPUT\_OUTPUT for the input/output parameters, to SQL\_PARAM\_OUTPUT for the output parameters, to SQL\_PARAM\_INPUT\_OUTPUT\_STREAM for the stream input/output parameters or to SQL\_PARAM\_OUTPUT\_STREAM for the stream output parameters. The default is SQL\_PARAM\_INPUT.

**SQL\_DESC\_PRECISION[All]**

This SQLSMALLINT record field includes the number of effective integer for the exact numeric type, and the number of bits of mantissa (binary precision) for the approximate numeric type. Or, it includes the number of digits in fractional seconds part of SQL\_TYPE\_TIME, SQL\_TYPE\_TIMESTAMP, or SQL\_INTERVAL\_SECOND data type. The field is undefined for all other data types.

The field value may be different from the value of the precision defined in ODBC 2.x.

**SQL\_DESC\_ROWVER[Implementation descriptors] (read-only)**

This SQLSMALLINT record field indicates whether the column is automatically updated by DBMS when the row is updated (e.g. timestamp of SQL server). The value of record field is set to SQL\_TRUE if the column is the versioning column. Otherwise, it is set to SQL\_FALSE. The column attribute is similar to calling SQLSpecialColumns with IdentifierType of SQL\_ROWVER to determine whether to automatically update the column.

**SQL\_DESC\_SCALE[All]**

This SQLSMALLINT record field includes the number of decimal places defined in the decimal and numeric data types. The field is not defined for all other data types.

The field value may be different from the value of the scale defined in ODBC 2.x.

**SQL\_DESC\_SCHEMA\_NAME[IRDs] (read-only)**

This read-only SQLCHAR\* record field includes the schema name of the base table including the column. The return value is driver-dependent if the column is a part of an expression or view. If the data source does not support the schema or can not identify the schema name, then this variable contains an empty string.

**SQL\_DESC\_SEARCHABLE[IRDs] (read-only)**

This read-only SQLSMALLINT record field sets one of the following values.

- It is set to SQL\_PRED\_NONE if the column can not be used in WHERE clause. (It is the same as SQL\_UNSEARCHABLE of ODBC 2.X.)
- It is set to SQL\_PRED\_CHAR if the column can be used in a WHERE clause but only with the LIKE predicate.
- It is set to SQL\_PRED\_BASIC if the column can be used with all comparison operators except for LIKE in WHERE clause. (It is the same as SQL\_EXCEPT\_LIKE of ODBC 2.x.)
- It is set to SQL\_PRED\_SEARCHABLE if the column can be used with all comparison operators in WHERE clause.



**SQL\_DESC\_TABLE\_NAME[IRDS] (read-only)**

This read-only SQLCHAR\* record field includes the base table name containing this column. The return value is driver-dependent if the column is an expression or a part of view.

**SQL\_DESC\_TYPE[All]**

This SQLSMALLINT record field includes an abbreviated SQL or C data types for all data types except for the datetime or interval data type. The field specifies SQL\_DATETIME or SQL\_INTERVAL for datetime or interval data type.

Whenever the field includes SQL\_DATETIME or SQL\_INTERVAL, SQL\_DESC\_DATETIME\_INTERVAL\_CODE field should include the appropriate server code of the concise form. SQL\_DESC\_TYPE includes SQL\_DATETIME for the datetime data type, and SQL\_DESC\_DATETIME\_INTERVAL\_CODE field includes the sub code specifying the datetime data type. SQL\_DESC\_TYPE includes SQL\_INTERVAL for the interval data type and SQL\_DESC\_DATETIME\_INTERVAL\_CODE field includes the sub code specifying the interval data type.

The values of SQL\_DESC\_TYPE and SQL\_DESC\_CONCISE\_TYPE fields are interdependent. The other field should be set when one of the fields is set. SQL\_DESC\_TYPE can be set by calling SQLSetDescField or SQLSetDescRec. SQL\_DESC\_CONCISE\_TYPE can be set by calling SQLBindCol, SQLBindParameter or SQLSetDescField.

If SQL\_DESC\_TYPE is set to the concise data type which is not interval nor datetime data type, SQL\_DESC\_CONCISE\_TYPE field is set to the same value and SQL\_DESC\_DATETIME\_INTERVAL\_CODE field is set to 0.

If SQL\_DESC\_TYPE is set to the verbose data type of the datetime or interval data type (SQL\_DATETIME or SQL\_INTERVAL) and SQL\_DESC\_DATETIME\_INTERVAL\_CODE field is set to the appropriate sub code, SQL\_DESC\_CONCISE\_TYPE field is set to the value corresponding to the concise data type. When trying to set SQL\_DESC\_TYPE to one of the concise datetime or interval data types, SQLSTATE HY021 (Inconsistent descriptor information) will be returned.

If SQL\_DESC\_TYPE field is set by calling SQLBindCol, SQLBindParameter or SQLSetDescField, the following fields are set to the default values described in the following table. The remaining field values of the same record are undefined.

SQL_DESC_TYPE value	Other fields implicitly set
SQL_CHAR, SQL_VARCHAR, SQL_C_CHAR, SQL_C_VARCHAR	SQL_DESC_LENGTH is set to 1. SQL_DESC_PRECISION is set to 0.
SQL_DATETIME	When SQL_DESC_DATETIME_INTERVAL_CODE is set to SQL_CODE_DATE or SQL_CODE_TIME, SQL_DESC_PRECISION is set to 0. When it is set to SQL_DESC_TIMESTAMP, SQL_DESC_PRECISION is set to 6.
SQL_DECIMAL, SQL_NUMERIC,	SQL_DESC_SCALE is set to 0. SQL_DESC_PRECISION is set to the implementation-defined precision for each data type.

SQL_DESC_TYPE value	Other fields implicitly set
SQL_C_NUMERIC	
SQL_FLOAT, SQL_C_FLOAT	SQL_DESC_PRECISION is set to the implementation-defined precision for SQL_FLOAT.
SQL_INTERVAL	If SQL_DESC_DATETIME_INTERVAL_CODE is set to interval data type, SQL_DESC_DATETIME_INTERVAL_PRECISION is set to 2 (default interval leading precision). When interval has the part of seconds, SQL_DESC_PRECISION is set to 6 (default interval seconds precision).

When the application sets the field of the descriptor by calling `SQLSetDescField` not `SQLSetDescRec`, the application should firstly define the data type. When doing like this, the other fields described in the table above are implicitly set. If any value is not allowed to set implicitly, the application can call `SQLSetDescField` or `SQLSetDescRec` to set the value explicitly.

#### **SQL\_DESC\_TYPE\_NAME[Implementation descriptors] (read-only)**

This read-only `SQLCHAR*` record field includes the data source dependent type name (CHAR, VARCHAR etc.). If the data type name is unknown, the variable contains an empty string.

#### **SQL\_DESC\_UNNAMED[Implementation descriptors]**

If `SQL_DESC_NAME` field is set, the `SQLSMALLINT` record field in the row descriptor is set to one of `SQL_NAME` or `SQL_UNNAMED` by the driver. If `SQL_DESC_NAME` field includes the column alias or the column alias is not used, the driver sets `SQL_DESC_UNNAMED` field to `SQL_NAMED`. If the application sets `SQL_DESC_NAME` field of IPD to the parameter name or alias, the driver sets `SQL_DESC_UNNAMED` of IPD to `SQL_NAMED`. If column name or alias does not exist, the driver sets `SQL_DESC_UNNAMED` field to `SQL_UNNAMED`.

The application sets `SQL_DESC_UNNAMED` field of IPD to `SQL_UNNAMED`. If the application tries to set `SQL_DESC_UNNAMED` field of IPD to `SQL_NAMED`, the driver returns `SQLSTATE HY091` (Invalid descriptor field identifier). If the application tries to set `SQL_DESC_UNNAMED` field of IRD (read-only), `SQLSTATE HY091` (Invalid descriptor field identifier) will be returned.

#### **SQL\_DESC\_UNSIGNED[Implementation descriptors] (read-only)**

The read-only `SQLSMALLINT` record field is set to `SQL_TRUE` if the column type is the unsigned or non-numeric, or it is set to `SQL_FALSE` if the column type is signed.

#### **SQL\_DESC\_UPDATABLE[IRDs] (read-only)**

This read-only `SQLSMALLINT` record field is set to one of the following values.

- It is set to `SQL_ATTR_READ_ONLY` if the result set column is read-only.
- It is set to `SQL_ATTR_WRITE` if the result set column is read and write.
- It is set to `SQL_ATTR_READWRITE_UNKNOWN` if the updatability of the result set column is unknown.

`SQL_DESC_UPDATABLE` describes the updatability of the column (It is not the column in the base t

able.) in the result set. The updatability of the column in the base table whose result set columns are based on can be different from the value in the field. The updatability of the column is based on the definition of the data type, user privilege and result set itself. If the updatability of the column is unsure, `SQL_ATTR_READWRITE_UNKNOWN` should be returned.

### **SQL\_DESC\_CHAR\_LENGTH\_UNITS[Ai] (read-only)**

This `SQLSMALLINT` record field indicates the length unit of the column whose SQL type is `SQL_CHAR`, `SQL_VARCHAR` and `SQL_LONGVARCHAR`.

- `SQL_CLU_CHARACTERS`: The length unit is CHARACTER. For example, data of "문자열" refers to the length of 3, if the encoding type is UHC(Unified Hangul Code).
- `SQL_CLU_OCTETS`: The length unit is OCTETS. For example, data of "문자열" refers to the length of 6, if the encoding type is UHC(Unified Hangul Code).
- `SQL_CLU_NONE`: The length unit is undefined. It is the value returned for SQL type except for the SQL types listed above.

## **Consistency Check**

Concurrency check is automatically implemented by the driver each time the application passes the value to `SQL_DESC_DATA_PTR` of `ARD`, `APD`, or `IPD`. If anything of the fields is inconsistent with other fields, `SQLSetDescField` will return `SQLSTATE HY021` (Inconsistent descriptor information). For more information, refer to **Consistency Check** of `SQLSetDescRec`.

# SQLSetDescRec

## Conformance

Introduced version: ODBC 3.0

Standards compliance: ISO 92

## Overview

SQLSetDescRec function sets the multiple descriptor fields affecting the buffer bound to a data type or column or parameter data.

## Syntax

```
SQLRETURN SQLSetDescRec(
    SQLHDESC      DescriptorHandle,
    SQLSMALLINT   RecNumber,
    SQLSMALLINT   Type,
    SQLSMALLINT   SubType,
    SQLLEN        Length,
    SQLSMALLINT   Precision,
    SQLSMALLINT   Scale,
    SQLPOINTER    DataPtr,
    SQLLEN *      StringLengthPtr,
    SQLLEN *      IndicatorPtr);
```

## Arguments

### DescriptorHandle

[Input] It is the descriptor handle. IRD handle can not be set.

### RecNumber

[Input] It indicates the descriptor record including the fields to be set. The descriptor record starts from 0, and the 0 record is a bookmark record. The argument should be equal to or bigger than 0. If RecNumber is bigger than SQL\_DESC\_COUNT, then SQL\_DESC\_COUNT is changed to RecNumber value.

### Type

[Input] It is the value which sets SQL\_DESC\_TYPE field for the descriptor record.

**SubType**

[Input] It is the value which sets SQL\_DESC\_DATETIME\_INTERVAL\_CODE field for a record type of SQL\_DATETIME or SQL\_INTERVAL.

**Length**

[Input] It is the value which sets SQL\_DESC\_OCTET\_LENGTH field for the descriptor record.

**Precision**

[Input] It is the value which sets SQL\_DESC\_PRECISION field for the descriptor record.

**Scale**

[Input] It is the value which sets SQL\_DESC\_SCALE field for the descriptor record.

**DataPtr**

[Deferred Input or Output] It is the value which sets SQL\_DESC\_DATA\_PTR field for the descriptor record. DataPtr can be set to a NULL pointer.

DataPtr argument can be set to a NULL pointer to set SQL\_DESC\_DATA\_PTR field to a NULL pointer. If the handle in DescriptorHandle argument is related to ARD, it unbinds the column.

**StringLengthPtr**

[Deferred Input or Output] It is the value which sets SQL\_DESC\_OCTET\_LENGTH\_PTR field for the descriptor record. StringLengthPtr can be set to a NULL pointer to set SQL\_DESC\_OCTET\_LENGTH\_PTR field to a NULL pointer.

**IndicatorPtr**

[Deferred Input or Output] It is the value which sets SQL\_DESC\_INDICATOR\_PTR field of the descriptor record. IndicatorPtr can be set to a NULL pointer to set SQL\_DESC\_INDICATOR\_PTR to a NULL pointer.

**Returns**

SQL\_SUCCESS, SQL\_SUCCESS\_WITH\_INFO, SQL\_ERROR, SQL\_INVALID\_HANDLE

**Diagnosis**

SQLSTATE	Error	Description
01000	General warning	It is the driver-specific informational message. (The function returns SQL_SUCCESS_WITH_INFO.)
07009	Invalid descriptor index	RecNumber argument is set to 0, and DescriptorHandle refers to the IPD handle.  RecNumber argument is bigger than the maximum number of columns or parameters supported by the data source, and DescriptorHandle argument is APD, IPD or ARD.

SQLSTATE	Error	Description
		RecNumber argument is 0, and DescriptorHandle argument refers to the implicitly allocated APD. (The error does not occur for the explicitly assigned application descriptor. This is because it is unknown whether the explicitly allocated application descriptor is APD or ARD until the execution time.)
08S01	Communication link failure	Before the function processing is completed, the connection between the driver and the data source is failed.
HY000	General error	It is an error without specific SQLSTATE, and the error message returned by SQLGetDiagRec in *MessageText buffer describes error message and its cause.
HY001	Memory allocation error	The driver can not allocate the memory required for execution or completion of the function.
HY010	Function sequence error	The asynchronously executing function is called for StatementHandle related to DescriptorHandle, and this function is still being executed when SQLSetDescRec is called.
HY013	Memory management error	The function is not executed because the underlying memory object can not be accessed because of the low memory condition.
HY016	Cannot modify an implementation row descriptor	DescriptorHandle argument is related to IRD.
HY021	Inconsistent descriptor information	The Type field, or other field related to SQL_DESC_TYPE field of the descriptor is not valid or consistent.
HY090	Invalid string or buffer length	The driver is set to ODBC 2.x driver, and the descriptor is set to ARD, and ColumnNumber argument is set to 0 and the value specified in BufferLength argument is not 4.
HY117	Connection is suspended due to unknown transaction state. Only disconnect and read-only functions are allowed	For more information about the suspended state, refer to <b>SQLEndTran</b> .
HYT01	Connection timeout expired	The connection timeout period is expired before the data source response to the request. The connection timeout interval can be set via SQL_ATTR_CONNECTION_TIMEOUT of SQLSetConnectAttr.
IM001	Driver does not support this function	The driver does not support the function.

## Description

The application can call `SQLSetDescRec` to set the following fields for a column or parameter.

- `SQL_DESC_TYPE`
- `SQL_DESC_DATETIME_INTERVAL_CODE` (For the record of `SQL_DATETIME` or `SQL_INTERVAL` type)
- `SQL_DESC_OCTET_LENGTH`
- `SQL_DESC_PRECISION`
- `SQL_DESC_SCALE`
- `SQL_DESC_DATA_PTR`
- `SQL_DESC_OCTET_LENGTH_PTR`
- `SQL_DESC_INDICATOR_PTR`



If calling `SQLSetDescRec` fails, the content of the descriptor record identified by `RecNumber` argument is not defined.

When binding a column or parameter, `SQLSetDescRec` allows to change the multiple fields which affect the binding without calling `SQLBindCol`, `SQLBindParameter` or calling `SQLSetDescField` multiple times. `SQLSetDescRec` can set the descriptor fields which are not related to the current statement. `SQLBindParameter` can set more fields than `SQLSetDescRec`, and it can set the fields of APD and IPD with a single call and it does not require a descriptor handle.



The `SQL_ATTR_USE_BOOKMARKS` statement attribute should be set before calling `SQLSetDescRec` with `RecNumber` argument of 0 to set bookmark fields. It is not necessary but is strongly recommended.

## Consistency Check

The consistency check is automatically implemented by the driver whenever the application sets `SQL_DESC_DATA_PTR` field of APD, ARD, or IPD. If any of the fields is not consistent with other fields, `SQLSetDescRec` will return `SQLSTATE HY021`. (Inconsistent descriptor information)

Whenever the application sets `SQL_DESC_DATA_PTR` field of APD, ARD or IPD, the driver checks the value of `SQL_DESC_TYPE` field, and checks if the values applicable to that `SQL_DESC_TYPE` field is valid and consistent. The check is implemented when `SQLBindParameter` or `SQLBindCol` is called or whenever `SQLSetDescRec` is called to APD, ARD or IPD. The consistency check includes the following descriptor fields.

- `SQL_DESC_TYPE` field should be one of the valid ODBC C, SQL type or the driver-specific SQL type. `SQL_DESC_CONCISE_TYPE` field should be one of the valid ODBC C, SQL Type or the driver-specific SQL type, and it includes the simplified datetime and interval types.
- If `SQL_DESC_TYPE` record field is `SQL_DATETIME` or `SQL_INTERVAL`, `SQL_DESC_DATETIME_INTERVAL`

L\_CODE field should be one of the valid datetime or interval codes. (For more information refer to the description of SQL\_DESC\_DATETIME\_INTERVAL\_CODE field in **SQLSetDescField**.)

- If SQL\_DESC\_TYPE field is a NUMERIC type, SQL\_DESC\_PRECISION and SQL\_DESC\_SCALE fields are checked whether they are valid.
- If SQL\_DESC\_CONCISE\_TYPE field is the time or timestamp data type an interval type with a seconds component, or one of the interval data types with a time component, SQL\_DESC\_PRECISION field is checked whether it is a valid second precision.
- If SQL\_DESC\_CONCISE\_TYPE is an interval data type, SQL\_DESC\_DATETIME\_INTERVAL\_PRECISION field is checked to be a valid interval leading precision value.

SQL\_DESC\_DATA\_PTR field of IPD is not generally set. The application can do so to force the consistency check for the IPD fields. Consistency check can not be executed in IRD. The value of SQL\_DESC\_DATA\_PTR field of IPD is not actually stored and it can not be retrieved via SQLGetDescField or SQLGetDescRec. The setting is made only to force the consistency check.



# SQLSetEnvAttr

## Conformance

Introduced version: ODBC 3.0

Standards compliance: ISO 92

## Overview

SQLSetEnvAttr sets the environment management attributes.

## Syntax

```
SQLRETURN SQLSetEnvAttr(  
    SQLHENV     EnvironmentHandle,  
    SQLINTEGER  Attribute,  
    SQLPOINTER  ValuePtr,  
    SQLINTEGER  StringLength);
```

## Arguments

### EnvironmentHandle

[Input] It is the environment handle.

### Attribute

[Input] They are listed in **Description**.

### ValuePtr

[Input] It is a pointer to the value which is related to an attribute. Depending on the value of Attribute, ValuePtr points to a 32 bit integer value or null-terminated character.

### StringLength

[Input] If ValuePtr points to the string or binary buffer, the argument should be the length of \*ValuePtr. The argument should include the number of bytes in string for the character string data.

If ValuePtr is an integer, StringLength is ignored.

## Returns

SQL\_SUCCESS, SQL\_SUCCESS\_WITH\_INFO, SQL\_ERROR, SQL\_INVALID\_HANDLE

## Diagnosis

SQLSTATE	Error	Description
01000	General warning	It is the driver-specific informational message. (The function returns SQL_SUCCESS_WITH_INFO.)
01S02	Option value changed	The driver does not support the value specified in ValuePtr and replaces it with a similar value. (The function returns SQL_SUCCESS_WITH_INFO.)
HY000	General error	It is an error without specific SQLSTATE, and the error message returned by SQLGetDiagRec in *MessageText buffer describes error message and its cause.
HY001	Memory allocation error	The driver can not allocate the memory required for execution or completion of the function.
HY009	Invalid use of null pointer	The attribute argument identifies an environment attribute which requires a string value, and ValuePtr argument is a NULL pointer.
HY010	Function sequence error	The connection handle is allocated to EnvironmentHandle.  SQL_ATTR_ODBC_VERSION is not set to SQLSetEnvAttr, Attribute is different from SQL_ATTR_ODBC_VERSION. If SQLAllocHandleStd is used, SQL_ATTR_ODBC_VERSION does not need to be explicitly specified.
HY013	Memory management error	The function is not executed because the underlying memory object cannot be accessed because of the low memory condition.
HY024	Invalid attribute value	Considering the specified attribute value, the value of ValuePtr is not valid.
HY090	Invalid string or buffer length	StringLength argument is smaller than 0. (It is not SQL_NTS.)
HY092	Invalid attribute/option identifier	The specified value of attribute argument is not valid in ODBC version supported by the driver.
HY117	Connection is suspended due to unknown transaction state. Only disconnect and read-only functions are allowed	For more information about the suspended state, refer to <b>SQLEndTran</b> .
HYC00	Optional feature not implemented	The specified value of attribute argument is valid for the ODBC environment attribute supported by the driver but it is not supported by the driver.  An attribute argument is SQL_ATTR_OUTPUT_NTS, and ValuePtr is SQL_FALSE.

## Description

The application can call `SQLSetEnvAttr` only when connection handle allocated to the environment handle does not exist. The environment attributes which is set by the application persist until `SQLFreeHandle` is called to the environment handle. It is recommended to allocate and use only one environment handle.

The information format set through `ValuePtr` is dependent on the specified attribute. `SQLSetEnvAttr` accepts one attribute information of two different formats which are the null-termination string or 32 bits integer value. Each attribute format is described in the description of the attribute.

The driver-specific environment attributes does not exist.

The connection attribute can not be set with `SQLSetEnvAttr`. If it is tried, `SQLSTATE HY092` (Invalid attribute/option identifier) will be returned.

Attribute	ValuePtr contents
SQL_ATTR_CONNECTION_POOLING (ODBC 3.8)	It is not supported by the driver.
SQL_ATTR_CP_MATCH (ODBC 3.0)	It is not supported by the driver.
SQL_ATTR_ODBC_VERSION (ODBC 3.0)	<p>32-bit integer which indicates whether a particular feature is operated as ODBC 2.x or ODBC 3.x. The following values are used to set the attribute.</p> <ul style="list-style-type: none"> <li>• SQL_OV_ODBC3_80: The driver manager and driver exhibit the following ODBC 3.8 behaviors. <ul style="list-style-type: none"> <li>◦ The driver expects and returns ODBC 3.x code value for DATE, TIME, TIMESTAMP.</li> <li>◦ The driver returns ODBC 3.x SQLSTATE codes when <code>SQLError</code>, <code>SQLGetDiagField</code> or <code>SQLGetDiagRec</code> is called.</li> <li>◦ <code>CatalogName</code> argument of <code>SQLTables</code> allows the pattern search.</li> </ul> </li> <li>• SQL_OV_ODBC3: The driver manager and driver exhibit the following ODBC 3.x behaviors. <ul style="list-style-type: none"> <li>◦ The driver expects and returns ODBC 3.x code value for DATE, TIME, TIMESTAMP.</li> <li>◦ The driver returns ODBC 3.x SQLSTATE codes when <code>SQLError</code>, <code>SQLGetDiagField</code> or <code>SQLGetDiagRec</code> is called.</li> <li>◦ <code>CatalogName</code> argument of <code>SQLTables</code> allows the pattern search.</li> <li>◦ The driver manager does not support the extensibility of C data types.</li> </ul> </li> <li>• SQL_OV_ODBC2: The driver manager and driver exhibit the following ODBC 2.x behaviors. It is very useful when the ODBC 2.x application operates in ODBC 3.x. <ul style="list-style-type: none"> <li>◦ The driver expects and returns ODBC 2.x code value for DATE, TIME, TIMESTAMP.</li> <li>◦ The driver returns ODBC 2.x SQLSTATE codes when <code>SQLError</code>, <code>SQLGetDiagField</code></li> </ul> </li> </ul>

Attribute	ValuPtr contents
	<p>eld or SQLGetDiagRec is called.</p> <ul style="list-style-type: none"> <li>◦ CatalogName argument of SQLTables does not allow the pattern search.</li> <li>◦ The driver manager does not support the extensibility of C data types.</li> </ul> <p>The application should set the environment attribute value before calling any function which has SQLHENV argument, or it returns SQLSTATE HY010 (Function sequence error). It is driver-specific whether additional behavior exists for these environmental flags.</p>
SQL_ATTR_OUTPUT_NTS (ODBC 3.0)	It is not supported by the driver.

# SQLSetParam

## Conformance

Introduced version: ODBC 1.0

Standards compliance: It is not available.

## Overview

ODBC 1.0 function `SQLSetParam` is replaced with ODBC 2.0 function `SQLBindParameter`. For more information, refer to [SQLBindParameter](#).

# SQLSetPos

## Conformance

Introduced version: ODBC 1.0

Standards compliance: ODBC

## Overview

SQLSetPos sets the cursor position in the row set and allows the application to update the data in the row set or to update or delete the data in the result set.

## Syntax

```
SQLRETURN SQLSetPos(  
    SQLHSTMT      StatementHandle,  
    SQLSETPOSIROW RowNumber,  
    SQLUSMALLINT  Operation,  
    SQLUSMALLINT  LockType);
```

## Arguments

### StatementHandle

[Input] It is the statement handle.

### RowNumber

[Input] It is the row position in the row set which is specified with Operation argument to implement the operation. If RowNumber is 0, the operation is applied to all rows in the row set.

For more information, refer to **Description** section.

### Operation

[Input] The operations to perform are SQL\_POSITION, SQL\_REFRESH, SQL\_UPDATE, SQL\_DELETE.

SQL\_ADD value of Operation argument is not used in ODBC 3.x any more. The ODBC 2.x driver will be required to support SQL\_ADD for the backward compatibility. This feature is replaced by calling SQLBulkOperations with operation of SQL\_ADD. When ODBC 3.x application is performed with ODBC 2.x driver, the driver manager maps a call of SQLBulkOperations with an operation of SQL\_ADD to a call of SQLSetPos with an operation of SQL\_ADD.

For more information, refer to **Description** section.

## LockType

[Input] The way to lock the row is specified after implementing the operation specified in Operation argument.

SQL\_LOCK\_NO\_CHANGE, SQL\_LOCK\_EXCLUSIVE, SQL\_LOCK\_UNLOCK

For more information, refer to **Description** section.

## Returns

SQL\_SUCCESS, SQL\_SUCCESS\_WITH\_INFO, SQL\_NEED\_DATA, SQL\_STILL\_EXECUTING, SQL\_ERROR, SQL\_INVALID\_HANDLE

## Diagnosis

SQLSTATE	Error	Description
01000	General warning	It is the driver-specific informational message. (The function returns SQL_SUCCESS_WITH_INFO.)
01001	Cursor operation conflict	Operation argument is SQL_DELETE or SQL_UPDATE. One or more rows are deleted/ updated, or any row is not deleted/ updated.  Operation argument is SQL_DELETE or SQL_UPDATE, and optimistic concurrency causes the operation failure. (The function returns SQL_SUCCESS_WITH_INFO.)
01004	String data, right truncation	Operation argument is SQL_REFRESH, and string or binary data returned for a column(s) with a data type of SQL_C_CHAR or SQL_C_BINARY truncates n on white space character or non-NULL binary data.
01S01	Error in row	RowNumber argument is 0, and an error occurred in one or more rows while the operation which is specified in operation argument is executed.  (If an error occurs on one or more, but not all, rows of a multirow operation, SQL_SUCCESS_WITH_INFO is returned. If an error occurs on a single row operation, SQL_ERROR is returned)  (If the driver is ODBC 2.x and the cursor library is not used, then this SQLSTATE occurs only when SQLSetPos is called after SQLExtendedFetch.)
01S07	Fractional truncation	If an operation argument is SQL_REFRESH and the buffer type of the application is not SQL_C_CHAR or SQL_C_BINARY, and the data returned to the application buffer for one or more columns are truncated. For the numeric data types, the fractional parts of the number are truncated. For time, timestamp, and interval data types including a time component, the fractional parts of the time are truncated.
07006	Restricted data type attribute violation	The column data value of the result set can not be converted to the data type specified in TargetType when SQLBindCol is called.

SQLSTATE	Error	Description
	tion	
07009	Invalid descriptor index	Operation argument is SQL_REFRESH or SQL_UPDATE, and the column value which is bigger than the number of columns in the result set is bound.
21S02	Degree of derived table does not match column list	Operation argument is SQL_UPDATE, and updatable column does not exist because all bound column are released, read-only or the value in bound length/indicator buffer is SQL_COLUMN_IGNORE.
22001	String data, right truncation	Operation argument is SQL_UPDATE, and the assignment of a character or binary value to a column causes the truncation of a non empty string (for character), or non-null string (for binary) or bytes.
22003	Numeric value out of range	<p>Operation argument is SQL_UPDATE, and the assignment of a numeric value to a column in the result set causes the truncation of whole part of the number.</p> <p>Operation argument is SQL_REFRESH, and returning the numeric value for one or more bound column causes the loss of significant digits.</p>
22007	Invalid datetime format	<p>Operation argument is SQL_UPDATE, and the assignment of date or timestamp value to a column in the result set causes the year, month, day field to be out of range.</p> <p>Operation argument is SQL_REFRESH, and returning date or timestamp value for one or more bound column causes the year, month, day field to be out of range.</p>
22008	Date/time field overflow	<p>Operation argument is SQL_UPDATE, and the performance of datetime arithmetic on data being sent to a column in the result set causes a datetime field (the year, month, day, hour, minute, or second field) of the result being outside the permissible range of values for the field, or being invalid based on the Gregorian calendar's natural rules for datetimes.</p> <p>Operation argument is SQL_REFRESH, and the performance of datetime arithmetic on data being retrieved from the result set causes a datetime field (the year, month, day, hour, minute, or second field) of the result being outside the permissible range of values for the field, or being invalid based on the Gregorian calendar's natural rules for datetimes.</p>
22015	Interval field overflow	<p>The Operation argument is SQL_UPDATE, and assigning an exact numeric or interval C type to an interval SQL data type causes a loss of significant digits.</p> <p>The Operation argument is SQL_UPDATE, and when assigning to an interval SQL type, representation of the value of the C type does not exist in the interval SQL type.</p> <p>The Operation argument is SQL_REFRESH, and assigning from an exact nu</p>



SQLSTATE	Error	Description
		<p>meric or interval SQL type to an interval C type causes a loss of significant digits in the leading field.</p> <p>The Operation argument is SQL_REFRESH, and when assigning to an interval C type, representation of the value of the SQL type does not exist in the interval C type.</p>
22018	Invalid character value for cast specification	<p>Operation argument is SQL_REFRESH, and C type is the exact or approximate numeric, datetime or interval data types. The SQL type of the column is a character data type. And the column value is not a valid character for the bound C type.</p> <p>Operation argument is SQL_UPDATE, and the SQL type is the exact or approximate numeric, datetime or interval data type. The C type of the column is SQL_C_CHAR. And the column value is not a valid character for the bound SQL type.</p>
23000	Integrity constraint violation	<p>Operation argument is SQL_DELETE or SQL_UPDATE, and it violates the integrity constraints.</p>
24000	Invalid cursor state	<p>StatementHandle is in the executed state but the result is not related to StatementHandle.</p> <p>The cursor is open to StatementHandle, but SQLFetch or SQLFetchScroll is not called.</p> <p>The cursor is open to StatementHandle and SQLFetch or SQLFetchScroll is called. But the cursor is positioned before the starting point of the result set or after the end of the result set.</p> <p>Operation argument is SQL_DELETE, SQL_REFRESH or SQL_UPDATE.</p>
40001	Serialization failure	<p>The transaction is rolled back due to a resource deadlock with another transactions.</p>
40003	Statement completion unknown	<p>The connection is failed during the function execution, and the status of transaction can not be determined.</p>
42000	Syntax error or access violation	<p>The driver can not lock the rows as needed to implement the operation requested in the operation argument.</p> <p>The driver can not lock the rows as requested in the LockType argument.</p>
44000	WITH CHECK OPTION violation	<p>Operation argument is SQL_UPDATE, and update on a viewed table or the table derived from the viewed table which was created by specifying WITH_CHECK_OPTION is performed to prevent the existence of one or more rows affected by the update in the viewed table.</p>
HY000	General error	<p>It is an error without specific SQLSTATE, and the error message returned by SQLGetDiagRec in *MessageText buffer describes error message and its cause.</p>

SQLSTATE	Error	Description
HY001	Memory allocation error	The driver can not allocate the memory required for execution or completion of the function.
HY008	Operation cancelled	<p>The asynchronous processing is activated for StatementHandle. SQLCancel or SQLCancelHandle is called on StatementHandle before the function is called and completed, and the function is called again on StatementHandle.</p> <p>The function is called, and before it completed execution, SQLCancel or SQLCancelHandle is called on the StatementHandle from a different thread in a multithread application.</p>
HY010	Function sequence error	<p>The asynchronously executing function is called for the StatementHandle when SQLSetPos was executed, and this function is still being executed when SQLSetPos is called.</p> <p>SQLExecute, SQLExecDirect or SQLMoreResults is called for StatementHandle, and SQL_PARAM_DATA_AVAILABLE is returned, and the function is called before the data was retrieved from the streamed parameters.</p> <p>The asynchronously executing function is called for the StatementHandle, and this function is still being executed when this function is called.</p> <p>SQLExecute, SQLExecDirect or SQLMoreResults is executed in StatementHandle, and SQL_NEED_DATA is returned, and the function is executed before all data is sent.</p> <p>The driver is ODBC 2.x, and SQLSetPos is called in StatementHandle after SQLFetch is called.</p>
HY011	Attribute cannot be set now	The driver version is ODBC 2.x, SQL_ATTR_ROW_STATUS_PTR statement attribute is set, and SQLSetPos is called before SQLFetch, SQLFetchScroll or SQLExtendedFetch is called at the time.
HY013	Memory management error	The function is not executed because the underlying memory object can not be accessed because of the low memory condition.
HY090	Invalid string or buffer length	Operation argument is SQL_UPDATE.
HY092	Invalid attribute identifier	<p>The value which is specified in Operation argument is not valid.</p> <p>The value which is specified in LockType argument is not valid.</p> <p>Operation argument is SQL_UPDATE or SQL_DELETE, and SQL_ATTR_CONCURRENCY statement attribute is SQL_ATTR_CONCUR_READ_ONLY.</p>
HY107	Row value out of range	The value which is specified in RowNumber argument is bigger than the number of rows in the row set.
		The cursor can not be positioned in the row set because the cursor which is

SQLSTATE	Error	Description
HY109	Invalid cursor position	<p>related to StatementHandle is set to forward-only. For more information, refer to the description of SQL_ATTR_CURSOR_TYPE attribute of SQLSetStmtAttr.</p> <p>Operation argument is SQL_UPDATE, SQL_DELETE or SQL_REFRESH, and the row which is identified by RowNumber argument is deleted or returned.</p> <p>RowNumber argument is 0, and operation argument is SQL_POSITION.</p> <p>SQLSetPos is called after SQLBulkOperations is called and before SQLFetchScroll or SQLFetch is called.</p>
HY117	Connection is suspended due to unknown transaction state. Only disconnect and read-only functions are allowed.	For more information about the suspended state, refer to <b>SQLEndTran</b> .
HYC00	Optional feature not implemented	The driver or data source does not support the operation requested in operation argument or LockType argument.
HYT00	Timeout expired	The query timeout period is expired before returning the entire result set from the data source. The timeout can be set via SQL_ATTR_QUERY_TIMEOUT of SQLSetStmtAttr.
HYT01	Connection timeout expired	The connection is expired before the data source responds to the request. The timeout can be set via SQL_ATTR_CONNECTION_TIMEOUT of SQLSetStmtAttr.
IM001	Driver does not support this function	The driver which is related to StatementHandle does not support the function.
IM017	Polling is disabled in asynchronous notification mode	Whenever using the notification model, polling can not be used.
IM018	SQLCompleteAsync has not been called to complete the previous asynchronous operation on this handle.	If the previous function call for the handle returns SQL_STILL_EXECUTING and if the notification mode is activated, SQLCompleteAsync should be called for the handle to do post processing and complete the operation.

## Description

### RowNumber Argument

RowNumber argument specifies the number of rows in the row set affected by the operation implementation specified in Operation argument. If RowNumber is 0, it is applied to all rows in the row set. RowNumber should be from 0 up to the number of rows in the row set.

The array is 0-based 0 in C language but the RowNumber is 1-based. For example, when updating the fifth row in the row set, the application updates the row set buffer of the array index 4, but RowNumber specifies to 5.

All operations position the cursor on the row specified by RowNumber. The following operation requires the cursor position.

- Positioned update or delete statements
- Calling SQLGetData
- Calling SQLSetPos with the SQL\_DELETE, SQL\_REFRESH or SQL\_UPDATE option

### Operation Argument

Operation argument supports the following operations. The application calls SQLGetInfo with the information type of SQL\_DYNAMIC\_CURSOR\_ATTRIBUTES1, SQL\_FORWARD\_ONLY\_CURSOR\_ATTRIBUTES1, SQL\_KEYSET\_CURSOR\_ATTRIBUTES1 or SQL\_STATIC\_CURSOR\_ATTRIBUTES1 (depending on the cursor type.) to verify the options supported by the data source.

Operation argument	Operation
SQL_POSITION	The driver positions the cursor at the row specified in RowNumber. The content of row status array which is pointed by SQL_ATTR_ROW_OPERATION_PTR statement attribute is ignored by SQL_POSITION.
SQL_REFRESH	It is not supported by the driver.
SQL_UPDATE	It is not supported by the driver.
SQL_DELETE	It is not supported by the driver.

### LockType Argument

LockType argument provides the method for the application to control the concurrency. In most case, the data source which provides the concurrency level and transaction supports SQL\_BLOCK\_NO\_CHANGE value to LockType argument.

LockType argument specifies the lock state of rows after executing SQLSetPos. If the driver can not lock the row either to perform the requested operation or to satisfy the LockType argument, it returns SQL\_ERROR and SQLSTATE 42000(Syntax error or access violation).

Although LockType argument is specified in a statement, it is applied to all statements of the same privileges on the connection. The special lock which is acquired by a statements on the connection can be unlocked by another statement on the same connection.

A row locked through SQLSetPos remains locked until the application calls SQLSetPos for the row with LockType set to SQL\_LOCK\_UNLOCK, or until the application calls SQLFreeHandle for the statement or SQLFreeStmt with the SQL\_CLOSE option. When the driver supports the transaction, the row lock through SQLSetPos is unlocked when the application commits or rolls back the transaction on the connection by calling SQLEndTran. (If the cursor is closed when a transaction is committed or rolled back as indicated by the of SQL\_CURSOR\_COMMIT\_BEHAVIOR and SQL\_CURSOR\_ROLLBACK\_BEHAVIOR information types returned by SQLGetInfo.)

LockType argument supports the following lock types. The application calls SQLGetInfo with the SQL\_DYNAMIC\_CURSOR\_ATTRIBUTES1, SQL\_FORWARD\_ONLY\_CURSOR\_ATTRIBUTES1, SQL\_KEYSET\_CURSOR\_ATTRIBUTES1 or SQL\_STATIC\_CURSOR\_ATTRIBUTES1 information type to verify the lock supported by the data source.

LockType argument	Lock type
SQL_LOCK_NO_CHANGE	The driver or data source ensures the locking or unlocking of the same row as it was before SQLSetPos is called. The value of LockType does not allow explicit row-level locking so that any lock required by the current concurrency and transaction isolation levels can be used.
SQL_LOCK_EXCLUSIVE	The driver or data source performs the exclusive lock on a row. The statement on other connection or in other application can not be used to acquire any locks on the row.
SQL_LOCK_UNLOCK	The driver or data source releases the lock.

When the update and delete operations are performed in SQLSetPos, the application uses the following LockType argument.

- An application calls SQLSetPos with operation set to SQL\_REFRESH, and LockType set to SQL\_LOCK\_EXCLUSIVE to guarantee that the row is not updated after it is retrieved.
- If the application sets LockType to SQL\_LOCK\_NO\_CHANGE, the driver guarantees the update or delete operation only when the application specifies SQL\_CONCUR\_LOCK for SQL\_ATTR\_CONCURRENCY statement attribute.
- If the application specifies SQL\_CONCUR\_ROWVER or SQL\_CONCUR\_VALUES for SQL\_ATTR\_CONCURRENCY statement attribute, the driver compares the version or value of the row and denies the operation when the row is changes since the application fetched the row.
- If the application specifies SQL\_CONCUR\_READ\_ONLY for SQL\_ATTR\_CONCURRENCY statement attribute, the driver denies any update or delete operation.

For more information about SQL\_ATTR\_CONCURRENCY statement attribute, refer to [SQLSetStmtAttr](#).

## Status and Operation Array

The following status and operation arrays are used when `SQLSetPos` is called.

- The row status array includes the status value of each row data in the row set. The driver sets the status value in the array after calling `SQLFetch`, `SQLFetchScroll`, `SQLBulkOperations` or `SQLSetPos`. The array is pointed to by `SQL_ATTR_ROW_STATUS_PTR` statement attribute.
- The row operation array includes each row value in the row set which indicates whether `SQLSetPos` call for the bulk operation is ignored or performed. Each element in the array sets one of `SQL_ROW_PROCEED` or `SQL_ROW_IGNORE`. The array is pointed to by `SQL_ATTR_ROW_OPERATION_PTR` statement attribute.

The number of elements in the status and operation array should be equal to the number of rows in the row set (as defined by the `SQL_ATTR_ROW_ARRAY_SIZE` statement attribute).

For more information about the row status array, refer to [SQLFetch](#).

For more information about the row operation array, refer to [Ignoring Rows in the Bulk Operation](#).

## Using SQLSetPos

The application should perform the following steps before using `SQLSetPos`.

1. If the application calls `SQLSetPos` with operation set to `SQL_UPDATE`, call `SQLBindCol` (or `SQLSetDescRec`) for each column to specify its data type and bind buffers for the column's data and length.
2. If the application calls `SQLSetPos` with operation set to `SQL_DELETE` or `SQL_UPDATE`, call `SQLColAttribute` to make sure that the columns to be deleted or updated are updatable.
3. The result set is generated by calling `SQLExecDirect`, `SQLExecute` or the catalog function.
4. The data is retrieved by calling `SQLFetch` or `SQLFetchScroll`.

## Deleting Data Using SQLSetPos

An application calls `SQLSetPos` with `RowNumber` set to the number of the row to delete and calls operation set to `SQL_DELETE`, to delete data by using `SQLSetPos`.

After the data is deleted, the driver changes the value in the implementation row status array for the appropriate row to `SQL_ROW_DELETED` (or `SQL_ROW_ERROR`).

## Updating Data Using SQLSetPos

The application can pass the data to the column through one of the bound buffer or once or more `SQLPutData` calls. Columns whose data is passed with `SQLPutData` are known as data-at-execution columns. Usually it may be used to transfer data to `SQL_LONGVARBINARY` and `SQL_LONGVARCHAR` and it can be mixed with other columns.

## Updating Data Using SQLSetPos in Application

1. Place value in the data and length/indicator buffer bound with SQLBindCol.
  - For general columns, the application positions the new column value in \*TargetValuePtr buffer and the value length in \*StrLen\_or\_IndPtr buffer. If the row should not be updated, the application positions SQL\_ROW\_IGNORE in the row element in the row operation array.
  - For data-at-execution columns, the application positions an application-defined value, such as the column number, in the \*TargetValuePtr buffer. The value can be used later to identify the column. The application positions the macro result of SQL\_LEN\_DATA\_AT\_EXEC(length) in \*StrLen\_or\_IndPtr buffer. If the SQL data type of the column is SQL\_LONGVARIABLE, SQL\_LONGVARIABLE\_CHAR or the source-defined long data type and the driver returns Y to SQL\_NEED\_LONG\_DATA information type of SQLGetInfo, length is the number of bytes to be sent to the parameter. Otherwise, it is not a negative and it should be ignored.
2. Call SQLSetPos with the operation argument set to SQL\_UPDATE to update the row of data.
  - If data-at-execution columns do not exist, the processing is completed.
  - If data-at-execution columns exist, the function returns SQL\_NEED\_DATA and proceeds the step 3.
3. Call SQLParamData to retrieve the address of \*TargetValuePtr buffer for the first data-at-execution column to be processed. SQLParamData returns SQL\_NEED\_DATA. The application retrieves the application-defined value in \*TargetValuePtr buffer.



- Though data-at-execution parameter is similar to the data-at-execution column, but each value which is returned by SQLParamData is different.
- Data-at-execution parameters are parameters in an SQL statement for which data will be sent with SQLPutData when the statement is executed with SQLExecDirect or SQLExecute. They are bound to SQLBindParameter or SQLSetDescRec by setting the descriptors. The value which is returned by SQLParamData is the 32 bits value and it is sent to SQLBindParameter of ParameterValuePtr argument.
- Data-at-execution columns are columns in a row set for which data will be sent with SQLPutData when a row is updated with SQLSetPos. They are bound with SQLBindCol. The value returned by SQLParamData is the address of the row in the \*TargetValuePtr buffer which is being processed.

4. Call SQLPutData once or more times to transfer data to the column. If all data values can not be returned in \*TargetValuePtr buffer specified in SQLPutData, multiple calls are needed. Only when the character data of C language is sent to the column with a character, binary or a data source data type, or when the binary data of C language is sent to to the column with a character, binary or a data so

urce data type, then multiple calls of SQLPutData are allowed for the same column.

5. Call SQLParamData again to indicate all data are sent to the column.
  - If more data-at-execution columns exist, then SQLParamData returns SQL\_NEED\_DATA and the address of the TargetValuePtr buffer for the next data-at-execution column to be processed. The application repeats the steps 4 and 5.
  - If data-at-execution columns do not exist any more, then the processing is completed. If the statement is successfully executed, SQLParamData returns SQL\_SUCCESS or SQL\_SUCCESS\_WITH\_INFO. If execution is failed, SQL\_ERROR is returned. At this point, SQLParamData returns any SQLSTATE which can be returned by SQLSetPos.

If the data is updated, the driver changes the value in the implementation row status array for the appropriate row to SQL\_ROW\_UPDATED.

If the operation is canceled or an error occurs in SQLParamData or SQLPutData, after SQLSetPos returns SQL\_NEED\_DATA and before data is transferred for all data-at-execution columns, the application can call only SQLCancel, SQLGetDiagField, SQLGetDiagRec, SQLGetFunctions, SQLParamData, or SQLPutData for the statement or the connection related to the statement. At this point, if another function is called, SQL\_ERROR and SQLSTATE HY010 (Function sequence error) are returned.

If the application calls SQLCancel while the driver still needs the data of data-at-execution columns, the driver cancels the operation. The application can call SQLSetPos again later. Cancellation does not affect the cursor state or the current cursor position.

When SELECT-list of the query specification related to the cursor includes one or more references in the same column, the driver defines whether an error occurs or the driver ignores the duplicated reference and implements the requested operation.

## Executing the Bulk Operation

If the RowNumber argument is 0, the driver performs the operation specified in the operation argument for every row in the rowset which has a value of SQL\_ROW\_PROCEED in its field in the row operation array pointed to by SQL\_ATTR\_ROW\_OPERATION\_PTR statement attribute. This is a valid value of the RowNumber argument for an operation argument of SQL\_DELETE, SQL\_REFRESH, or SQL\_UPDATE, but not SQL\_POSITION. SQLSetPos with an operation of SQL\_POSITION and a RowNumber equal to 0 will return SQLSTATE HY109 (Invalid cursor position).

If an error occurs in the entire row set, such as SQLSTATE HYT00 (Timeout expired), the driver returns SQL\_ERROR and the appropriate SQLSTATE. The contents of the row set buffers are undefined, and the cursor position is unchanged.

If an error occurs in a single row, the driver performs the followings.

- It sets the row element in the row status array pointed by SQL\_ATTR\_ROW\_STATUS\_PTR statement a



tribute to SQL\_ROW\_ERROR.

- It adds one or more SQLSTATE to an error in the error queue, and sets SQL\_DIAG\_ROW\_NUMBER field of the diagnostic data structure.

If the driver completes the remaining row operation in the row set after an error or warning is processed, SQL\_SUCCESS\_WITH\_INFO is returned. Therefore, the error queue includes zero or more SQLSTATE for the rows which return the errors. The driver stops the operation after processing an error or warning and returns SQL\_ERROR.

If the driver returns a warning such as SQLSTATE 01004 (Data truncated), then the driver returns a warning applied to the entire row set or unknown rows in the row set before returning the error information which is applied to a specific row. It returns warnings for specific rows together with other error information about those rows.

If RowNumber is 0 and operation is SQL\_UPDATE, SQL\_REFRESH or SQL\_DELETE, then the number of rows on which SQLSetPos operates is set by SQL\_ATTR\_ROWS\_FETCHED\_PTR statement attribute.

If RowNumber is 0 and the operation is SQL\_DELETE, SQL\_REFRESH or SQL\_UPDATE, then the current row after the operation is as same as the row before the operation.

## Ignoring Rows in the Bulk Operation

The row operation array can be used to specify the row which should be ignored in the current row set during the bulk operation with SQLSetPos. The application should perform the following steps to make the driver ignore one or more rows in the driver during the bulk operation.

1. It calls SQLSetStmtAttr to set the SQL\_ATTR\_ROW\_OPERATION\_PTR statement attribute to point to an array of SQLUSMALLINTs. This field can also be set by calling SQLSetDescField to set the SQL\_DESC\_ARRAY\_STATUS\_PTR header field of the ARD, which requires that an application obtains the descriptor handle.
2. It sets each element in the row operation array to one of the following values.
  - Setting to SQL\_ROW\_IGNORE it indicates that the row is excluded in the bulk operation.
  - Setting to SQL\_ROW\_PROCEED it indicates that the row is included in the bulk operation.
3. It performs the bulk operation by calling SQLSetPos.

The following rules are applied to the row operation array.

- SQL\_ROW\_IGNORE and SQL\_ROW\_PROCEED affect only bulk operations using SQLSetPos with an operation of SQL\_DELETE or SQL\_UPDATE. They do not affect calling SQLSetPos with an operation of SQL\_REFRESH or SQL\_POSITION.
- The pointer is set to NULL by default.
- If the pointer is NULL, then all rows are updated like as all elements are set to SQL\_ROW\_PROCEED.
- Setting the element to SQL\_ROW\_PROCEED does not guarantee occurrence of the operation in a par

ticular row. If a certain row in the row set has the `SQL_ROW_ERROR` status, the driver can not update that row regardless of whether the application specified `SQL_ROW_PROCEED`. The application should always check the row status array to see whether the operation was successful.

- `SQL_ROW_PROCEED` is defined as 0 in the header file. The application can initialize the row operation array to 0 to process all rows.
- If the n-th element of the row status array is set to `SQL_ROW_IGNORE` and the bulk update or delete operation is executed by calling `SQLSetPos`, the n-th row in the row set remains unchanged after calling `SQLSetPos`.
- The application should automatically set a read-only column to `SQL_ROW_IGNORE`.

## Ignoring Columns in the Bulk Operation

The application can set the value in the bound length/indicator buffer to `SQL_COLUMN_IGNORE` so that it can avoid unnecessary processing diagnostics caused by attempting to update one or more read-only columns. For more information, refer to [SQLBindCol](#).

# SQLSetScrollOptions

## Conformance

Introduced version: ODBC 1.0

Standards compliance: It is not available.

## Overview

SQLSetScrollOptions function in ODBC 2.0 is replaced with calling SQLGetInfo and SQLSetStmtAttr in ODBC 3.x.



When the driver manager maps SQLSetScrollOptions for the application which operates with ODBC 3.x driver which does not support SqlSetScrollOptions, the driver manager sets SQL\_ROW\_SET\_SIZE statement option, not the SQL\_ATTR\_ROW\_ARRAY\_SIZE statement attribute in Rows etSize argument of SQLSetScrollOptins. As a result, SQLSetScrollOptions can not be used by an application when fetching multiple rows by calling SQLFetch or SQLFetchScroll, and it can be used only when fetching multiple rows by calling SQLExtendedFetch.

# SQLSetStmtAttr

## Conformance

Introduced version: ODBC 3.0

Standards compliance: ISO 92

## Overview

SQLSetStmtAttr sets the attributes related to the statements.

## Syntax

```
SQLRETURN SQLSetStmtAttr(  
    SQLHSTMT      StatementHandle,  
    SQLINTEGER    Attribute,  
    SQLPOINTER   ValuePtr,  
    SQLINTEGER    StringLength);
```

## Arguments

### StatementHandle

[Input] It is the statement handle.

### Attribute

[Input] It is the option to be set. For more information, refer to the **Description** section.

### ValuePtr

[Input] It is the value which is related to the attribute. ValuePtr can be one of the followings according to the attribute value.

- ODBC descriptor handle
- SQLUINTEGER value
- SQLULEN value
- One of the following pointers
  - Null-termination character string
  - Binary buffer
  - SQLLEN, SQLULEN, SQLUSMALLINT values or the array of values
  - Driver-defined value

If Attribute argument is the driver-specific value, ValuePtr may be an integer.

### StringLength

[Input] If an attribute is an ODBC-defined attribute and ValuePtr points to a string or binary buffer, the argument is the length of \*ValuePtr. If Attribute is a driver-defined attribute and ValuePtr is an integer, the argument is ignored. StringLength may have one of the following values.

If Attribute is a driver-defined attribute, the application indicates the nature of the attribute to the driver manager by setting StringLength argument.

- If ValuePtr is a string pointer, Stringlength is the string length or SQL\_NTS.
- If ValuePtr is a binary buffer, the application stores SQL\_LEN\_BINARY\_ATTR (length) macro result in StringLength. StringLength has a negative value.
- If ValuePtr is a pointer of a different value other than a string or a binary buffer, StringLength must have SQL\_IS\_POINTER value.
- If ValuePtr includes a fixed length value, StringLength is SQL\_IS\_INTEGER or SQL\_IS\_UIINTEGER.

### Returns

SQL\_SUCCESS, SQL\_SUCCESS\_WITH\_INFO, SQL\_ERROR, SQL\_INVALID\_HANDLE

### Diagnosis

SQLSTATE	Error	Description
01000	General warning	It is the driver-specific informational message. (The function returns SQL_SUCCESS_WITH_INFO.)
01S02	Option value changed	It is temporarily replaced with a similar value because the driver does not support the value specified in ValuePtr or the value specified in ValuePtr is invalid due to the implementation working conditions. (SQLGetStmtAttr can be called to see which value is temporarily replaced.) The replaced value is valid for the StatementHandle until the cursor is closed, and it is changed to the previous value when the cursor is closed. The statement attributes which can be changed are as follows.  SQL_ATTR_CONCURRENCY, SQL_ATTR_CURSOR_TYPE, SQL_ATTR_KEYSET_SIZE, SQL_ATTR_MAX_LENGTH, SQL_ATTR_MAX_ROWS, SQL_ATTR_QUERY_TIMEOUT, SQL_ATTR_ROW_ARRAY_SIZE, SQL_ATTR_SIMULATE_CURSOR.  (The function returns SQL_SUCCESS_WITH_INFO.)
08S01	Communication link failure	Before the function processing is completed, the connection between the driver and the data source is failed.
24000	Invalid cursor state	Attribute is SQL_ATTR_CONCURRENCY, SQL_ATTR_CURSOR_TYPE, SQL_ATTR_SIMULATE_CURSOR or SQL_ATTR_USE_BOOKMARKS, and the cursor is open.

SQLSTATE	Error	Description
HY000	General error	It is an error without specific SQLSTATE, and the error message returned by SQLGetDiagRec in *MessageText buffer describes error message and its cause.
HY001	Memory allocation error	The driver can not allocate the memory required for execution or completion of the function.
HY009	Invalid use of null pointer	The statement attribute which is identified by Attribute argument requires the string attribute, and ValuePtr argument is a NULL pointer.
HY010	Function sequence error	<p>The asynchronously executing function is called for the connection handle related to StatementHandle, and this function is still being executed when SQLSetStmtAttr is called.</p> <p>SQLExecute, SQLExecDirect or SQLMoreResults are called for StatementHandle, and SQL_PARAM_DATA_AVAILABLE is returned. This function is called before the data is returned for the streamed parameters.</p> <p>The asynchronously executing function is called for StatementHandle, and is still being executed when the function is called.</p> <p>SQLExecute, SQLExecDirect, SQLBulkOperation or SQLSetPos are called for StatementHandle, and SQL_NEED_DATA is returned. This function is called before data is sent for all data-at-execution parameters or columns.</p>
HY011	Attribute cannot be set now	Attribute is SQL_ATTR_CONCURRENCY, SQL_ATTR_CURSOR_TYPE, SQL_ATTR_SIMULATE_CURSOR or SQL_ATTR_USE_BOOKMARKS, and the statement is prepared.
HY013	Memory management error	The function is not executed because the underlying memory object can not be accessed because of the low memory condition.
HY017	Invalid use of an automatically allocated descriptor handle	<p>Attribute argument is SQL_ATTR_IMP_ROW_DESC or SQL_ATTR_IMP_PARAM_DESC.</p> <p>Attribute argument is SQL_ATTR_APP_ROW_DESC or SQL_ATTR_APP_PARAM_DESC, and the value in ValuePtr is an implicitly allocated descriptor handle other than the handle originally allocated for the ARD or APD.</p>
HY024	Invalid attribute value	<p>Considering the specified Attribute value, the value in ValuePtr is invalid. (The driver manager returns this SQLSTATE only for the statement attribute and connection which allows the separate set such as SQL_ATTR_ACCESS_MODE or SQL_ATTR_ASYNC_ENABLE. The driver should verify the value in ValuePtr for other connection and statement attribute.)</p> <p>Attribute argument is SQL_ATTR_APP_ROW_DESC or SQL_ATTR_APP_PARAM_DESC, and ValuePtr is an explicitly allocated descriptor handle which is not on the same connection as the StatementHandle argument.</p>
HY090	Invalid string or buffer length	*ValuePtr is a string and StringLength is smaller than 0. (It is not SQL_NTS.)

SQLSTATE	Error	Description
HY092	Invalid attribute/ option identifier	The value specified for the Attribute argument is invalid for the version of ODBC supported by the driver.  The value which is specified in Attribute is the read-only attribute.
HY117	Connection is suspended due to unknown transaction state. Only disconnect and read-only functions are allowed	For more information about the suspended state, refer to <b>SQLEndTran</b> .
HYC00	Optional feature not implemented	The value which is specified in Attribute argument is valid in ODBC version supported by the driver but it is not supported by the driver.  Attribute argument is SQL_ATTR_ASYNC_ENABLE. When SQLGetInfo is called in InforType with SQL_ASYNC_MODE, then SQL_AM_CONNECTION is returned.  Attribute argument is SQL_ATTR_ENABLE_AUTO_IPD, and the value of SQL_ATTR_AUTO_IPD connection attribute is SQL_FALSE.
HYT01	Connection timeout expired	The connection timeout period is expired before the data source response to the request. The connection timeout period can be set via SQLSetConnectAttr of SQL_ATTR_CONNECTION_TIMEOUT.
IM001	Driver does not support this function	The driver does not support the function.
S1118	Driver does not support asynchronous notification	When calling SQLSetStmtAttr to set SQL_ATTR_ASYNC_STMT_EVENT the driver does not support the asynchronous notification.

## Description

The statement attribute is updated by calling SQLSetStmtAttr or it remains effective until the statement is deleted by SQLFreeHandle. Calling SQLFreeStmt with SQL\_CLOSE, SQL\_UNBIND or SQL\_RESET\_PARAMS option does not reset the statement attribute.

Some statements attributes is replaces with a similar value if the driver does not support the value specified in ValuePtr. The driver returns SQL\_SUCCESS\_WITH\_INFO and SQLSTATE 01S02 (Option value changed) for these cases. For example, if attribute is SQL\_ATTR\_CONCURRENCY and ValuePtr is SQL\_CONCURRENTOVERRIDE and the data source does not support it, the driver replace it with SQL\_CONCUR\_VALUES and returns SQL\_SUCCESS\_WITH\_INFO. The application calls SQLGetStmtAttr to obtain the replaced value.

The format of information set with ValuePtr depends on the value specified in Attribute. SQLSetStmtAttr

accepts one of attribute information types such as a different character string or integer. Each type is described in the description of the attribute. The type is applied to the information returned for each attribute in `SQLGetStmtAttr`. The length of the character string pointed to by the `ValuePtr` argument of `SQLSetStmtAttr` is `StringLength`.



- The feature whose statement attribute is set at the connection level by calling `SQLSetConnectAttr` may disappear in ODBC 3.x. The ODBC 3.x application should not set the statement attribute at the connection level. The ODBC 3.x statement attribute can not be set at the connection level except for `SQL_ATTR_METADATA_ID`, and `SQL_ATTR_ASYNC_ENABLE` attribute is both the connection attribute and the statement attribute, and it can be set at the connection level and the statement level.
- ODBC 3.x driver requires the option feature which sets the driver version to ODBC 2.x at the connection level if the driver should operate with the ODBC 2.x application.

## Statement Attribute to Set the Descriptor Field

Many statement attributes correspond to the header fields of the descriptor. Setting these attributes is the same result with setting the descriptor fields. Setting fields by calling `SQLSetStmtAttr` rather than calling `SQLSetDescField` has the advantage that a descriptor handle does not have to be obtained for the function call.



Calling `SQLSetStmtAttr` in a single statement may affect other statements. It happens when APD or ARD is explicitly assigned to the statement and it is related to other statements. `SQLSetStmtAttr` is applied to all statements related to this descriptor because it modifies APD or ARD. If it is not required operation, the application should separate this descriptor with other statements (by calling `SQLSetStmtAttr` to set the `SQL_ATTR_APP_ROW_DESC` or `SQL_ATTR_APP_PARAM_DESC` field to a different descriptor handle) before calling `SQLSetStmtAttr` again.

When the descriptor field is set as a result of the corresponding statement attribute being set, the field is set only for the applicable descriptors which are currently related to the statement identified by the `StatementHandle` argument, and the attribute setting does not affect any descriptor of the related statement in the future. When the descriptor field which is related to the statement handle is set to `SQLSetDescField`, the corresponding statement attribute is also set. If an explicitly allocated descriptor is dissociated from a statement, a statement attribute which corresponds to a header field will revert to the value of the field in the implicitly allocated descriptor.

When the statement is allocated, four descriptor handles are automatically allocated and is related to the statement. Explicitly allocated descriptor handles can be associated with the statement by calling `SQLAllocHandle` with an `HandleType` of `SQL_HANDLE_DESC` to allocate a descriptor handle and then calling `SQLS`



etStmtAttr to associate the descriptor handle with the statement.

The following is the statement attributes corresponding to the descriptor header field.

Statement attribute	Header field	Description
SQL_ATTR_PARAM_BIND_OFFSET_PTR	SQL_DESC_BIND_OFFSET_PTR	APD
SQL_ATTR_PARAM_BIND_TYPE	SQL_DESC_BIND_TYPE	APD
SQL_ATTR_PARAM_OPERATION_PTR	SQL_DESC_ARRAY_STATUS_PTR	APD
SQL_ATTR_PARAM_STATUS_PTR	SQL_DESC_ARRAY_STATUS_PTR	IPD
SQL_ATTR_PARAMS_PROCESSED_PTR	SQL_DESC_ROWS_PROCESSED_PTR	IPD
SQL_ATTR_PARAMSET_SIZE	SQL_DESC_ARRAY_SIZE	APD
SQL_ATTR_ROW_ARRAY_SIZE	SQL_DESC_ARRAY_SIZE	ARD
SQL_ATTR_ROW_BIND_OFFSET_PTR	SQL_DESC_BIND_OFFSET_PTR	ARD
SQL_ATTR_ROW_BIND_TYPE	SQL_DESC_BIND_TYPE	ARD
SQL_ATTR_ROW_OPERATION_PTR	SQL_DESC_ARRAY_STATUS_PTR	ARD
SQL_ATTR_ROW_STATUS_PTR	SQL_DESC_ARRAY_STATUS_PTR	IRD
SQL_ATTR_ROWS_FETCHED_PTR	SQL_DESC_ROWS_PROCESSED_PTR	IRD

## Statement Attributes

The following table describes currently defined attributes and the version of ODBC in which they were introduced.

Attribute	ValuePtr contents
SQL_ATTR_APP_PARAM_DESC (ODBC 3.0)	It is not supported by the driver.
SQL_ATTR_APP_ROW_DESC (ODBC 3.0)	It is not supported by the driver.
SQL_ATTR_ASYNC_ENABLE (ODBC 1.0)	It is not supported by the driver.
SQL_ATTR_ASYNC_STMT_EVENT (ODBC 3.8)	It is not supported by the driver.
SQL_ATTR_ASYNC_STMT_PCALLBACK (ODBC3.8)	It is not supported by the driver.
SQL_ATTR_ASYNC_STMT_PCONTEXT (ODBC 3.8)	It is not supported by the driver.
SQL_ATTR_ATOMIC_EXEC	SQLUSMALLINT: It is whether an atomic insert operation is operable.

Attribute	ValuePtr contents
UTION	<ul style="list-style-type: none"> <li>• SQL_ATOMIC_EXECUTION_OFF</li> <li>• SQL_ATOMIC_EXECUTION_ON</li> </ul>
SQL_ATTR_CONCURRENCY (ODBC 2.0)	<p>The default value of SQL_ATTR_CONCURRENCY is SQL_CONCUR_READ_ONLY.</p> <ul style="list-style-type: none"> <li>• SQLULEN: It is the value which specifies the cursor concurrency. <ul style="list-style-type: none"> <li>◦ SQL_CONCUR_READ_ONLY: The cursor is read-only and the update is not allowed.</li> <li>◦ SQL_CONCUR_LOCK: The cursor uses the minimum level locking enough to completely update the row.</li> <li>◦ SQL_CONCUR_ROWVER: The cursor uses the concurrency to control and compare the row version, such as SQLBase ROWID or Sybase TIMESTAMP.</li> <li>◦ SQL_CONCUR_VALUES: The cursor uses the concurrency to control and compare the values.</li> </ul> </li> </ul> <p>If SQL_ATTR_CURSOR_TYPE attribute is changed to the value which is not supported in SQL_ATTR_CONCURRENCY, the value of SQL_ATTR_CONCURRENCY may be changed at the execution time and a warning may occur when SQLExecDirect or SQLPrepare is called.</p> <p>While the driver supports SELECT FOR UPDATE statement and the statement is executed, an error occurs if SQL_ATTR_CONCURRENCY is changed to SQL_CONCUR_READ_ONLY. If SQL_ATTR_CONCURRENCY value is changed to SQL_ATTR_CURSOR_TYPE value which is supported by the driver, or to the value not supported by the driver, SQL_ATTR_CURSOR_TYPE value is changed at the execution time, and SQLSTATE 01S02 (Option value changed) may be returned when SQLExecDirect or SQLPrepare is executed.</p> <p>If the specified concurrency is not supported by the data source, the driver replaces it with other concurrency and returns SQLSTATE 01S02 (Option value changed). The driver replaces SQL_CONCUR_VALUES with SQL_CONCUR_ROWVER, or reverse. Also, SQL_CONCUR_LOCK is replaced with SQL_CONCUR_ROWVER, SQL_CONCUR_VALUES order. The validity of the replaced value is not confirmed until the execution time.</p>
SQL_ATTR_CURSOR_SCROLLABLE (ODBC 3.0)	<ul style="list-style-type: none"> <li>• SQLULEN: It is the value specifying the required support level of the application. Setting the attribute affects the next SQLExecDirect and SQLExecute. <ul style="list-style-type: none"> <li>◦ SQL_NONSCROLLABLE: It is the default value. The scroll cursor is not required to the statement handle. If the application calls SQLFetchScroll to the handle, the only valid value of FetchOrientation is SQL_FETCH_NEXT.</li> <li>◦ SQL_SCROLLABLE: The scroll cursor is required to the statement handle. When SQLFetchScroll is called, the application positions the cursor on the mode except the sequential mode and the valid value of FetchOrientation may be specified.</li> </ul> </li> </ul>
	<ul style="list-style-type: none"> <li>• SQLULEN: The value which determines whether the cursor of the statement handle can view the change in the result set generated by the other cursor. Setting t</li> </ul>

Attribute	ValuePtr contents
SQL_ATTR_CURSOR_SENSITIVITY (ODBC 3.0)	<p>The field affects the next calls of SQLExecDirect and SQLExecute. The application can read again the attribute value to obtain the initial state or its latest state set by the application.</p> <ul style="list-style-type: none"> <li>◦ SQL_UNSPECIFIED: It is the default value. It is unspecified what the cursor type is and whether cursors on the statement handle make visible the changes made to a result set by another cursor. The cursor of the statement handle can probably view none, some, or all such changes.</li> <li>◦ SQL_INSENSITIVE: All cursors of the statement handle can view only the result but they can not view any changes made by the other cursor. The insensitive cursor is read-only. It corresponds to a static cursor with a read-only concurrency.</li> <li>◦ SQL_SENSITIVE: It allows all cursors of the statement handle can view all of the changes in the result set generated by the other cursor.</li> </ul>
SQL_ATTR_CURSOR_TYPE (ODBC 2.0)	<ul style="list-style-type: none"> <li>• SQLULEN: It is the value which specifies the cursor type. <ul style="list-style-type: none"> <li>◦ SQL_CURSOR_FORWARD_ONLY: The cursor can only move forward.</li> <li>◦ SQL_CURSOR_KEYSET_DRIVEN: The driver stores and uses the keys as many as the number of rows specified in SQL_ATTR_KEYSET_SIZE statement attribute.</li> <li>◦ SQL_CURSOR_DYNAMIC: The driver stores and uses the key for only the row in the row set.</li> </ul> </li> </ul> <p>The default value is SQL_CURSOR_FORWARD_ONLY. The attribute can not be specified in the prepared SQL statement.</p> <p>If the specified cursor type is not supported by the data source, the driver replaces it with the other type and returns SQLSTATE 01S02 (Option value changed. The driver replaces the mixed or dynamic cursor with the keyset-driven or static cursor. The driver replaces a keyset-driven cursor with a static cursor.</p>
SQL_ATTR_ENABLE_AUTO_IPD (ODBC 3.0)	It is not supported by the driver.
SQL_ATTR_EXPLAIN_PLAN_OPTION	SQLUSMALLINT: Whether to create the plan information. <ul style="list-style-type: none"> <li>• SQL_EXPLAIN_PLAN_OFF: Plan information is not generated.</li> <li>• SQL_EXPLAIN_PLAN_ON: The SQL statement is performed and plan information is generated.</li> <li>• SQL_EXPLAIN_PLAN_ONLY: The SQL statement is not performed and plan information is generated.</li> </ul>
SQL_ATTR_EXPLAIN_PLAN_TEXT	It is the generated plan string. (read-only)
SQL_ATTR_FETCH_BOOKMARK_PTR (ODBC 3.0)	It is not supported by the driver.
SQL_ATTR_FETCH_FAILOV	SQLUSMALLINT: It is whether to use fetch failover.

Attribute	ValuePtr contents
ER	<ul style="list-style-type: none"> <li>SQL_FETCH_FAILOVER_OFF: It does not use fetch failover.</li> <li>SQL_FETCH_FAILOVER_ON: It uses fetch failover.</li> </ul>
SQL_ATTR_IMP_PARAM_DESCRIPTOR (ODBC 3.0)	It is not supported by the driver.
SQL_ATTR_IMP_ROW_DESCRIPTOR (ODBC 3.0)	It is not supported by the driver.
SQL_ATTR_KEYSET_SIZE (ODBC 2.0)	It is not supported by the driver.
SQL_ATTR_MAX_LENGTH (ODBC 1.0)	It is not supported by the driver.
SQL_ATTR_MAX_ROWS (ODBC 1.0)	<ul style="list-style-type: none"> <li>SQLULEN: It is the value corresponding to the maximum number of rows returned by SELECT statement. If *ValuePtr is equal to 0, the driver returns all rows.</li> </ul> <p>The purpose of this attribute is to reduce the network traffic. Notionally, it is applied when the result set is generated, and it limits the result set of the first ValuePtr rows. If the number of rows in the result set are bigger than ValuePtr, the result set is reduced.</p> <p>SQL_ATTR_MAX_ROWS is applied to all result set of the statement including those which are returned by the catalog functions. SQL_ATTR_MAX_ROWS sets the maximum number of cursor rows.</p> <p>If it is not sure if the SQL_ATTR_MAX_ROWS is to be properly implemented (If the limit of the result set size can not be implemented in the data source), the driver should not emulate the SQL_ATTR_MAX_ROWS operation for SQLFetch or SQLFetchScroll.</p> <p>The driver defines whether SQL_ATTR_MAX_ROWS is applied to the statements except for SELECT statement (such as the catalog functions).</p> <p>The attribute value is set on the cursor which is open. But it would not be immediately effective. In this case, the driver returns SQLSTATE 01S02 (Option value changed) and sets the attribute to its original value.</p>
SQL_ATTR_METADATA_ID	<ul style="list-style-type: none"> <li>SQLULEN: It is the value which specifies the way to process the string arguments of the catalog functions.</li> </ul> <p>If it is SQL_TRUE, catalog functions treat a string argument as an identifier. It is not case-sensitive. The driver removes the trailing spaces of the string whose range is not determined and converts them to uppercase. The driver removes the leading and trailing spaces of the strings whose range is determined and takes the string literally between delimiters. If one of the argument is set to a NULL pointer, the function returns SQL_ERROR and SQLSTATE HY009. (Invalid use of null pointer).</p>

Attribute	ValuePtr contents
(ODBC 3.0)	<p>If it is SQL_FALSE, catalog functions does not treat a string argument as an identifier. It is case-sensitive. They can either include a string search pattern or not, depending on the argument.</p> <p>The default value is SQL_FALSE.</p> <p>It is the TableType argument of SQLTables which takes a list of values, is not affected by this attribute.</p> <p>SQL_ATTR_METADATA_ID can be set in the connection level. (SQL_ATTR_METADATA_ID and SQL_ATTR_ASYNC_ENABLE are unique, and they are the statement attributes and at the same time they are the connection attributes.)</p> <p>For more information, refer to <b>Arguments of Catalog Function</b>.</p>
SQL_ATTR_NOSCAN (ODBC 1.0)	<p>It is not supported by the driver.</p>
SQL_ATTR_PARAM_BIND_OFFSET_PTR (ODBC 3.0)	<ul style="list-style-type: none"> <li>SQLULEN*: It is the value which indicates the offset added to a pointer to change the binding of the dynamic parameters. If the field is not NULL, the driver dereferences the pointer and adds the dereferenced value to each of the deferred fields in the descriptor record (SQL_DESC_DATA_PTR, SQL_DESC_INDICATOR_PTR, and SQL_DESC_OCTET_LENGTH_PTR), and it uses a new pointer value when binding. The default value is set to NULL.</li> </ul> <p>The bind offset is always directly added to SQL_DESC_DATA_PTR, SQL_DESC_INDICATOR_PTR, SQL_DESC_OCTET_LENGTH_PTR fields. If the offset is changed to a different value, the new value is still directly added to the descriptor field value. A new offset is not added to the field value plus previous offsets.</p> <p>Setting this statement attribute sets the SQL_DESC_BIND_OFFSET_PTR field in the APD header.</p>
SQL_ATTR_PARAM_BIND_TYPE (ODBC 3.0)	<ul style="list-style-type: none"> <li>SQLULEN: It represents the binding direction used for the dynamic parameter.</li> </ul> <p>The field is set to SQL_PARAM_BIND_BY_COLUMN which is for the column-wise binding. (The default value)</p> <p>To select the row-wise binding, the field is set to the structure length or the buffer instance which is bound to the dynamic parameter set. If the length includes the space for the padding of all the bound parameter and structure or the address of the bound parameter is increased to the specified length, the result should be buffered to point to the beginning of the next parameter. Using sizeof operator of ANSI C guarantees this operation.</p> <p>Setting this statement attribute sets the SQL_DESC_BIND_TYPE field in the APD head</p>

Attribute	ValuePtr contents
SQL_ATTR_PARAM_OPERATION_PTR (ODBC 3.0)	<p>er.</p> <ul style="list-style-type: none"> <li>SQLUSMALLINT*: It is the value which points to an array of SQLUSMALLINT values used to ignore the parameter while executing the SQL statement. Each value is SQL_PARAM_PROCEED (to execute the parameter) or SQL_PARAM_IGNORE (to ignore the parameter).</li> </ul> <p>The parameter set can be ignored during the process if it sets the status value of the array pointed by SQL_DESC_ARRAY_STATUS_PTR in APD. The parameter set is processed only if the status value is SQL_PARAM_PROCEED or the the array element is not set.</p> <p>The statement attribute can be set to a NULL pointer. In this case, the driver does not return the parameter status value. The attribute can be set at any time, but a new value is not used until the next SQLExecDirect or SQLExecute is called.</p> <p>If the bound parameter does not exist, the attribute is ignored.</p> <p>Setting this statement attribute sets the SQL_DESC_ARRAY_STATUS_PTR field in the APD header.</p>
SQL_ATTR_PARAM_STATUSES_PTR (ODBC 3.0)	<ul style="list-style-type: none"> <li>SQLUSMALLINT*: It is the value which points to SQLUSMALLINT array value including the status information value of each of the rows of the parameter value after calling SQLExecute or SQLExecDirect. The field is required only when PARAMSET_SIZE is bigger than 1. The status value may include the following values.               <ul style="list-style-type: none"> <li>SQL_PARAM_SUCCESS: The SQL statement is successfully executed for the parameter set.</li> <li>SQL_PARAM_SUCCESS_WITH_INFO: The SQL statement is successfully executed for the parameter set, but warning information is in the diagnostic data structure.</li> <li>SQL_PARAM_ERROR: An error occurs when processing the parameter set. Additional error information is in the diagnostic data structure.</li> <li>SQL_PARAM_UNUSED: The parameter set is not used because some previous parameter set caused an error which aborted further processing, or because SQL_PARAM_IGNORE is set for the parameter set in the array specified by the SQL_ATTR_PARAM_OPERATION_PTR.</li> <li>SQL_PARAM_DIAG_UNAVAILABLE: The driver treats the parameter arrays in a monolithic unit because it does not generate the error information level.</li> </ul> </li> </ul> <p>The statement attribute can be set to a NULL pointer, and the driver does not return the status value of the parameter. The attribute can be set at any time. But a new value is not used until the next SQLExecDirect or SQLExecute is called. Setting the attribute can affect the operation that outputs the parameter to the driver.</p> <p>Setting this statement attribute sets the SQL_DESC_ARRAY_STATUS_PTR field in the APD header.</p>

Attribute	ValuePtr contents
SQL_ATTR_PARAMS_PROCESSED_PTR (ODBC 3.0)	<ul style="list-style-type: none"> <li>SQLULEN*: It is the record field which points to the buffer returning the number of parameter sets processed and it includes the error set. If it is a NULL pointer, it is not returned.</li> </ul> <p>Setting this statement attribute sets SQL_DESC_ROWS_PROCESSED_PTR field of IPD header.</p> <p>If SQLExecDirect or SQLExecute that fills the buffer specified in the attribute does not return SQL_SUCCESS or SQL_SUCCESS_WITH_INFO, the buffer content is not defined.</p>
SQL_ATTR_PARAMSET_SIZE (ODBC 3.0)	<ul style="list-style-type: none"> <li>SQLULEN: It is the value which specifies the number of each of the parameter values. If SQL_ATTR_PARAMSET_SIZE is bigger than 1, SQL_DESC_DATA_PTR, SQL_DESC_INDICATOR_PTR, SQL_DESC_OCTET_LENGTH_PTR of APD point to the array. Each array constant is equal to the value of the field.</li> </ul> <p>If the bound parameter does not exist, the attribute is ignored.</p> <p>Setting this statement attribute sets SQL_DESC_ARRAY_SIZE field of APD header.</p>
SQL_ATTR_QUERY_TIMEOUT (ODBC 1.0)	<ul style="list-style-type: none"> <li>SQLULEN: The value of seconds that waits before the SQL statement is executed and returned to the application. If ValuePtr is 0 (the default value), timeout does not occur.</li> </ul> <p>If the specified time out value exceeds the maximum value of the data source or smaller than the minimum value of the data source, SQLSetStmtAttr replaces the value and returns SQLSTATE 01S02 (Option value changed).</p> <p>Even if SELECT statement is timeout the application does not need to call SQLCloseCursor to reuse the statement.</p> <p>Setting the query timeout of the statement attribute is valid for both synchronous and asynchronous modes.</p>
SQL_ATTR_RETRIEVE_DATA (ODBC 2.0)	<p>It is not supported by the driver.</p>
SQL_ATTR_ROW_ARRAY_SIZE (ODBC 3.0)	<ul style="list-style-type: none"> <li>SQLULEN: It is the value which specifies the number of rows returned by calling SQLFetch or SQLFetchScroll. It is also the number of rows of the bookmark array which is used in the bulk bookmark operation of SQLBulkOperations. The default value is 1.</li> </ul> <p>If the specified row set size exceeds the maximum row set size supported by the data source, the driver replaces the value and returns SQLSTATE 01S02 (Option value changed).</p> <p>Setting this statement attribute sets SQL_DESC_ARRAY_SIZE field of ARD header.</p>

Attribute	ValuePtr contents
SQL_ATTR_ROW_BIND_OFFSET_PTR (ODBC 3.0)	<ul style="list-style-type: none"> <li>SQLULEN: It is the value which points the added offset value to indicate the change of the column data binding. If the field is not NULL, the driver dereferences the pointer and adds the dereference value to each field in the descriptor record (SQL_DESC_DATA_PTR, SQL_DESC_INDICATOR_PTR, SQL_DESC_OCTET_LENGTH_PTR) and uses a new pointer value when it is bound. The default value is NULL.</li> </ul> <p>Setting this statement attribute sets SQL_DESC_BIND_OFFSET_PTR field of ARD header.</p>
SQL_ATTR_ROW_BIND_TYPE (ODBC 1.0)	<ul style="list-style-type: none"> <li>SQLULEN: It is the value which sets the binding direction when SQLFetch or SQLFetchScroll is called in the related statement. If SQL_BIND_BY_COLUMN value is set, the column-wise binding is selected. If the value to length of a structure or an instance of a buffer into which result columns will be bound is set, the row-wise binding is selected.</li> </ul> <p>If a length is specified, they should include space for all bound columns and any padding of the structure or buffer to ensure that when the address of a bound column is increased as the specified length, the result will point to the beginning of the same column in the next row. Using sizeof operator with the structure or union of ANSI C guarantees this operation.</p> <p>The column-wise binding is the default binding direction of SQLFetch and SQLFetchScroll.</p> <p>Setting this statement attribute sets SQL_DESC_BIND_TYPE field of ARD header.</p>
SQL_ATTR_ROW_NUMBER (ODBC 2.0)	<p>It is not supported by the driver.</p>
SQL_ATTR_ROW_OPERATION_PTR (ODBC 3.0)	<p>It is not supported by the driver.</p>
SQL_ATTR_ROW_STATUS_PTR (ODBC 3.0)	<ul style="list-style-type: none"> <li>SQLUSMALLINT*: It is the value which points to the SQLUSMALLINT array including the row status values after calling SQLFetch or SQLFetchScroll. The array has the elements as many as the number of rows included in the row set.</li> </ul> <p>The statement attribute can be set to a NULL pointer, and the driver does not return the row status values in this case. The attribute can be set at any time, but a new value is not used until the next call of SQLBulkOperations, SQLFetch, SQLFetchScroll or SQLSetPos.</p> <p>Setting this statement attribute sets SQL_DESC_ARRAY_STATUS_PTR of IRD header.</p> <p>The attribute is mapped to rgbRowStatus array of SQLExtendedFetch in ODBC 2.x driver.</p>



Attribute	ValuePtr contents
SQL_ATTR_ROWS_FETCHED_PTR (ODBC 3.0)	<ul style="list-style-type: none"> <li>SQLULEN*: It points to the buffer which returns the number of rows fetched after calling SQLFetch or SQLFetchScroll. It is the number of rows affected by a bulk operation performed by a call to SQLSetPos with an operation argument of SQL_REFRESH, or it is the number of rows affected by a bulk operation performed by SQLBulkOperations. The number of rows includes the error rows.</li> </ul> <p>Setting this statement attribute sets SQL_DESC_ROWS_PROCESSED_PTR field of the IRD header.</p> <p>When SQLFetch or SQLFetchScroll is called to fill the buffer pointed by the attribute, the contents of the buffer are not defined if SQL_SUCCESS or SQL_SUCCESS_WITH_INFO is not returned.</p>
SQL_ATTR_SIMULATE_CURSOR (ODBC 2.0)	It is not supported by the driver.
SQL_ATTR_USE_BOOKMARKS (ODBC 2.0)	It is not supported by the driver.

# SQLSetStmtOption

## Conformance

Introduced version: ODBC 1.0

Standards compliance: It is not available.

## Overview

SQLSetStmtOption function in ODBC 2.0 is replaced with SQLSetStmtAttr in ODBC 3.x.

For more information, refer to [SQLSetStmtAttr](#).

# SQLSpecialColumns

## Conformance

Introduced version: ODBC 1.0

Standards compliance: It is open group.

## Overview

SQLSpecialColumns function retrieves the following information for a column in the specified table.

- The optimal column set that uniquely identifies a row in the table
- The columns which are automatically updated when a row value is updated by the transaction

## Syntax

```
SQLRETURN SQLSpecialColumns(
    SQLHSTMT      StatementHandle,
    SQLSMALLINT   IdentifierType,
    SQLCHAR *     CatalogName,
    SQLSMALLINT   NameLength1,
    SQLCHAR *     SchemaName,
    SQLSMALLINT   NameLength2,
    SQLCHAR *     TableName,
    SQLSMALLINT   NameLength3,
    SQLSMALLINT   Scope,
    SQLSMALLINT   Nullable);
```

## Arguments

### StatementHandle

[Input] It is the statement handle.

### IdentifierType

[Input] It is the column type to return. It should be one of the following values.

- SQL\_BEST\_ROWID: It returns the optimal column or set of columns that, by retrieving values from the column(s), allows any row in the specified table to be uniquely identified. The column may be a pseudo column for the special purpose (ROWID of ORACLE, TID of INGRES), a general column or a column of a unique index on the table.

- **SQL\_ROWVER:** It returns the column or columns in the specified table, if any, which are automatically updated by the data source when any value in the row is updated by any transaction. (such as in SQLBase ROWID or Sybase TIMESTAMP).

### **CatalogName**

[Input] It is the table catalog. If the driver does not support the catalog, an empty string ("") is returned and the tables do not have a catalog. The catalog name can not include a string search pattern.

If **SQL\_ATTR\_METADATA\_ID** is set to **SQL\_TRUE**, **CatalogName** is treated as an identifier and it is not case-sensitive. If it is set to **SQL\_FALSE**, **CatalogName** is generally treated as a string argument and it is case-sensitive. For more information, refer to **Arguments of Catalog Function**.

### **NameLength1**

[Input] It is the length of \*CatalogName string.

### **SchemaName**

[Input] It is name of the table schema. It is the string search pattern for the schema name. If the driver does not support the schema, it returns an empty string ("") and the tables do not have a schema. **SchemaName** can not include a string search pattern.

If **SQL\_ATTR\_METADATA\_ID** is set to **SQL\_TRUE**, **SchemaName** is treated as an identifier and it is not case-sensitive. If it is set to **SQL\_FALSE**, **SchemaName** is an ordinary argument, it is treated literally and it is case-sensitive.

### **NameLength2**

[Input] It is the length of \*SchemaName string.

### **TableName**

[Input] It is name of the table. The argument can not be a NULL pointer. The table name can not include a string search pattern.

If **SQL\_ATTR\_METADATA\_ID** is set to **SQL\_TRUE**, **TableName** is treated as an identifier and it is not case-sensitive. If it is set to **SQL\_FALSE**, **TableName** is an ordinary argument, it is treated literally, and it is case-sensitive.

### **NameLength3**

[Input] It is the length of \*TableName string.

### **Scope**

[Input] It is minimum required scope of the rowid. The returned ROWID scope may be of a bigger scope. The value should be one of the followings.

- **SQL\_SCOPE\_CURROW:** The rowid is guaranteed to be valid only while it is positioned on that row. If it is updated or deleted by another transaction, the used ROWID is not retrieved.
- **SQL\_SCOPE\_TRANSACTION:** The rowid is guaranteed to be valid while the current transaction is maintained.
- **SQL\_SCOPE\_SESSION:** The rowid is guaranteed to be valid while the session is maintained. (It across the transaction boundaries.)

## Nullable

[Input] It checks that the particular column can have NULL value. It should be one of the followings.

- SQL\_NO\_NULLS: A particular column can not have NULL value. Some drivers do not support SQL\_NO\_NULLS and they will return an empty result set if SQL\_NO\_NULLS is specified. The application should be prepared this case and request SQL\_NO\_NULLS only if it is required.
- SQL\_NULLABLE: A particular column can have NULL value.

## Returns

SQL\_SUCCESS, SQL\_SUCCESS\_WITH\_INFO, SQL\_STILL\_EXECUTING, SQL\_ERROR, SQL\_INVALID\_HANDLE

## Diagnosis

SQLSTATE	Error	Description
01000	General warning	It is the driver-specific informational message. (The function returns SQL_SUCCESS_WITH_INFO.)
08S01	Communication link failure	Before the function processing is completed, the connection between the driver and the data source is failed.
24000	Invalid cursor state	A cursor is open on the StatementHandle, and SQLFetch or SQLFetchScroll had been called.  This error is returned by the Driver Manager if SQLFetch or SQLFetchScroll does not return SQL_NO_DATA, and is returned by the driver if SQLFetch or SQLFetchScroll returns SQL_NO_DATA.  A cursor is open on the StatementHandle, but SQLFetch or SQLFetchScroll is not called.
40001	Serialization failure	The transaction is rolled back due to a resource deadlock of other transactions.
40003	Statement completion unknown	The related connection is failed while executing this function, and the state of the transaction cannot be determined.
HY000	General error	It is an error without specific SQLSTATE, and the error message returned by SQLGetDiagRec in *MessageText buffer describes error message and its cause.
HY001	Memory allocation error	The driver can not allocate the required memory for execution or completion of the function.
HY008	Operation canceled	Asynchronous processing for StatementHandle is available and SQLCancel or SQLCancelHandle is called on StatementHandle before the function is called and completed. Then this function is called again on StatementHandle.  SQLCancel or SQLCancelHandle is called on StatementHandle from other

SQLSTATE	Error	Description
		er thread in the multithreaded application before the function is called and completed.
HY009	Invalid use of null pointer	<p>The TableName argument is a null pointer.</p> <p>The SQL_ATTR_METADATA_ID statement attribute is set to SQL_TRUE, the CatalogName argument is a null pointer, and the SQL_CATALOG_NAME InfoType returns that catalog names are supported.</p> <p>The SQL_ATTR_METADATA_ID statement attribute is set to SQL_TRUE, and the SchemaName argument is a null pointer.</p>
HY010	Function sequence error	<p>The asynchronously executing function is called for the connection handle related to StatementHandle, and this function is still being executed when SQLSpecialColumns is called.</p> <p>SQLExecute, SQLExecDirect, SQLMoreResults is called for StatementHandle, and SQL_PARAM_DATA_AVAILABLE is returned. The function is called, before the data is retrieved for all streamed parameters.</p> <p>The asynchronously executing function is called for StatementHandle, and is still being executed when this function is called.</p> <p>SQLExecute, SQLExecDirect, SQLBulkOperation or SQLSetPos are called for StatementHandle, and SQL_NEED_DATA is returned. This function is called before data is sent for all data-at-execution parameters or columns.</p>
HY013	Memory management error	The function is not executed because the underlying memory object cannot be accessed because of the low memory condition.
HY090	Invalid string or buffer length	<p>The value of a length arguments is smaller than 0 but it is not SQL_NTS.</p> <p>The value of a length arguments exceeds the maximum length value for the corresponding name.</p>
HY097	Column type out of range	An invalid IdentifierType value is specified.
HY098	Scope type out of range	An invalid scope value is specified.
HY099	Nullable type out of range	An invalid nullable value is specified.
HY117	Connection is suspended due to unknown transaction state. Only disconnect and read-only functions are allowed.	For more information about the suspended state, refer to <b>SQLEndTran</b> .

SQLSTATE	Error	Description
HYC00	Optional feature not implemented	<p>A catalog is specified, and the driver or data source does not support catalogs.</p> <p>A schema is specified, and the driver or data source does not support schemas.</p> <p>A string search pattern is specified, and all or one of the catalog name, table schema, table name, data source does not support it.</p> <p>The combination of the current settings of the SQL_ATTR_CONCURRENCY and SQL_ATTR_CURSOR_TYPE statement attributes is not supported by the driver or data source.</p> <p>The SQL_ATTR_USE_BOOKMARKS statement attribute is set to SQL_UB_VARIABLE, and the SQL_ATTR_CURSOR_TYPE statement attribute is set to a cursor type for which the driver does not support bookmarks.</p>
HYT00	Timeout expired	The query timeout period is expired before the data source returns the requested result. The time limit can be set via SQLSetStmtAttr of SQL_ATTR_CONNECTION_TIMEOUT.
HYT01	Connection timeout expired	The connection timeout period is expired before the data source responds to the request. The connection time limit can be set via SQLSetConnectAttr of SQL_ATTR_CONNECTION_TIMEOUT.
IM001	Driver does not support this function	The driver does not support the function.
IM017	Polling is disabled in a synchronous notification mode	Whenever using the notification model, polling can not be used.
IM018	SQLCompleteAsync had not been called to complete the previous asynchronous on this handle.	If the previous function call for the handle returns SQL_STILL_EXECUTING and if the notification mode is activated, then SQLCompleteAsync should be called for the handle to do post processing and complete the operation.

## Description

If IdentifierType argument is SQL\_BEST\_ROWID, SQLSpecialColumns returns a column or the column which uniquely identifies each row of the table. The column can be used in select-list or WHERE clause. SQLColumns returns various information of the table column, but it is not necessary to return the column which uniquely identifies each row nor does return a column automatically updated when any value in a row is updated by the transaction. For example, SQLColumns does not return ROWID which is the pseudo column of Oracle. It is the reason that SQLSpecialColumns is used to return information of particular column. For more information, refer to **Using Catalog Data**.



For more information about the general use, arguments, and returned data of ODBC catalog functions, refer to **Catalog Function**.

If column to uniquely identify each row in the table does not exist, SQLSpecialColumns does not return any column. Then, SQL\_NO\_DATA is returned when SQLFetch or SQLFetchScroll is called in the statement.

The characteristics which are specified in IdentifierType, scope, nullable arguments are not supported by the data source, SQLSpecialColumn returns an empty result set.

If SQL\_ATTR\_METADATA\_ID attribute is set to SQL\_TRUE, then CatalogName, SchemaName, TableName arguments are treated as identifiers and they can not use a NULL pointer. (For more information, refer to **Arguments of Catalog Function**.)

SQLSpecialColumns function returns a standard result set which is sorted by SCOPE.

The following columns are renamed in ODBC 3.x. Changing column name does not affect the backward compatibility because applications bind by column number.

ODBC 2.0 column	ODBC 3,x column
PRECISION	COLUMN_SIZE
LENGTH	BUFFER_LENGTH
SCALE	DECIMAL_DIGITS

SQLGetInfo function can be called with SQL\_MAX\_COLUMN\_NAME\_LEN option in the application to determine the actual length of COLUMN\_NAME column.

The following table lists the columns in the result set. The additional columns beyond the column 8(PSEUDO\_COLUMN) can be defined by the driver. The application should count from the end of the result set rather than specifying an explicit position to access the columns defined by the driver. For more information, refer to **Data Returning of Catalog Function**.

Column name	Column number	Data type	Description
SCOPE (ODBC 1.0)	1	Smallint	It is the actual scope of ROWID. It includes one of SQL_SCOPE_CURROW, SQL_SCOPE_TRANSACTION, or SQL_SCOPE_SESSION. If IdentifierType is SQL_ROWVER, NULL is returned. For more information about each value, refer to scope in <b>Syntax</b> .
COLUMN_NAME (ODBC 1.0)	2	Varchar not NULL	It is the column name. If the column does not have a name, the driver returns an empty string.
DATA_TYPE (ODBC 1.0)	3	Smallint not NULL	It is SQL data type. It may be the ODBC SQL data type or the SQL data type specified in the driver. All ODBC SQL data types are valid. For more information about SQL data types specified in the driver, refer to the documentation of the driver.



Column name	Column number	Data type	Description
TYPE_NAME (ODBC 1.0)	4	Varchar not NULL	It is name of the data source-dependent data type. e.g. CHAR, VARCHAR, MONEY, LONG VARBINARY, CHAR() FOR BIT DATA, etc.
COLUMN_SIZE (ODBC 1.0)	5	Integer	It is the column size in the data source.
BUFFER_LENGTH (ODBC 1.0)	6	Integer	It is the length in bytes of data transferred on an SQLGetData or SQLFetch operation if SQL_C_DEFAULT is specified. The numeric data may be different from the size of the data stored in the data source. The value is as same as COLUMN_SIZE for a string or binary data.
DECIMAL_DIGITS (ODBC 1.0)	7	Smallint	It is the number of decimal places of the column in the data source. NULL is returned if the number of decimal places can not be applied.
PSEUDO_COLUMN (ODBC 2.0)	8	Smallint	It displays whether the column is the pseudo-column such as Oracle ROWID. <ul style="list-style-type: none"> <li>• SQL_PC_UNKNOWN</li> <li>• SQL_PC_NOT_PSEUDO</li> <li>• SQL_PC_PSEUDO</li> </ul> <p>The pseudo-column is not allowed to quote an identifier in quotation marks returned in SQLFetchInfo for maximum interoperability.</p>

After the application retrieves the SQL\_BEST\_ROWID value. The application can use the retrieved values to reselect the row within the defined scope. It guarantees that SELECT statement returns either *no rows* or *one row*.

If the application does not find the row when the row is re-queried based on ROWID or the column, it is assumed that the row is deleted or the ROWID column is changed. Although ROWID is not changed, the other column of the row may be updated.

The columns which are returned for the column type SQL\_BEST\_ROWID are very useful when the application need to move forward or backward within a result set to retrieve the most recent data among the row set. The column(s) of ROWID are not updated while it is positioned on that row.

The ROWID columns remain valid even when the cursor is not positioned on the row. The application can determine it by checking the SCOPE column in the result set.

# SQLStatistics

## Conformance

Introduced version: ODBC 1.0

Standards compliance: ISO 92

## Overview

SQLStatistics retrieves a list of statistics about a single table and the indexes related to the table. The driver returns the information as a result set.

## Syntax

```
SQLRETURN SQLStatistics(  
    SQLHSTMT      StatementHandle,  
    SQLCHAR *     CatalogName,  
    SQLSMALLINT   NameLength1,  
    SQLCHAR *     SchemaName,  
    SQLSMALLINT   NameLength2,  
    SQLCHAR *     TableName,  
    SQLSMALLINT   NameLength3,  
    SQLUSMALLINT  Unique,  
    SQLUSMALLINT  Reserved);
```

## Arguments

### StatementHandle

[Input] It is the statement handle.

### CatalogName

[Input] It is the catalog name. If the driver does not support the catalog, an empty string ("") is returned and the tables do not have a catalog. The catalog name can not include a string search pattern.

If SQL\_ATTR\_METADATA\_ID is set to SQL\_TRUE, CatalogName is treated as an identifier and it is not case-sensitive. If it is set to SQL\_FALSE, CatalogName is treated as an ordinary argument, it is treated literally, and it is case-sensitive. For more information, refer to **Arguments of Catalog Function**.

**NameLength1**

[Input] It is the length of \*CatalogName string.

**SchemaName**

[Input] It is the schema name. If the driver does not support the schema, an empty string ("") is returned and the tables do not have a schema.

If SQL\_ATTR\_METADATA\_ID is set to SQL\_TRUE, SchemaName is treated as an identifier and it is not case-sensitive. If it is set to SQL\_FALSE, SchemaName is treated as an ordinary argument, it is treated literally, and it is case-sensitive.

**NameLength2**

[Input] It is the length of \*SchemaName string.

**TableName**

[Input] It is the table name. The argument can not be a NULL pointer. TableName does not include a string search pattern .

If SQL\_ATTR\_METADATA\_ID is set to SQL\_TRUE, SchemaName is treated as an identifier and it is not case-sensitive. If it is set to SQL\_FALSE, SchemaName is treated as an ordinary argument, it is treated literally, and it is case-sensitive.

**NameLength3**

[Input] It is the length of \*TableName string.

**Unique**

[Input] It is the index type. It can be SQL\_INDEX\_UNIQUE or SQL\_INDEX\_ALL.

**Reserved**

[Input] The importance of CARDINALITY and PAGES columns is displayed in the result set. The following options affect only the results of CARDINALITY and PAGES columns. The index information is returned even when CARDINALITY and PAGES are not returned.

- SQL\_ENSURE: It requests the driver to unconditionally search for statistics. (The driver which complies with Open Group standards, but does not support the ODBC extension can not support SQL\_ENSURE.)
- SQL\_QUICK: If it is readily available from the server, it requests the driver to unconditionally search for CARDINALITY and PAGES. The driver does not guarantee that the retrieved value is the current value. (The application which is registered in Open Group will always get SQL\_QUICK from ODBC 3.x-compliant drivers.)

**Returns**

SQL\_SUCCESS, SQL\_SUCCESS\_WITH\_INFO, SQL\_STILL\_EXECUTING, SQL\_ERROR, SQL\_INVALID\_HANDLE

## Diagnosis

SQLSTATE	Error	Description
01000	General warning	It is the driver-specific informational message. (The function returns SQL_SUCCESS_WITH_INFO.)
08S01	Communication link failure	Before the function processing is completed, the connection between the driver and the data source is failed.
24000	Invalid cursor state	<p>The cursor is open in StatementHandle, and SQLFetch or SQLFetchScroll is called.</p> <p>If SQLFetch or SQLFetchScroll does not return SQL_NO_DATA, the driver manager returns this error. If SQLFetch or SQLFetchScroll returns SQL_NO_DATA, the driver returns this error.</p> <p>The cursor is open in StatementHandle, but SQLFetch or SQLFetchScroll is not called.</p>
40001	Serialization failure	The transaction is rolled back due to a resource deadlock of other transactions.
40003	Statement completion unknown	The related connection fails during the function execution and the status of the transaction is not able to be checked.
HY000	General error	It is an error without specific SQLSTATE, and the error message returned by SQLGetDiagRec in *MessageText buffer describes error message and its cause.
HY001	Memory allocation error	The driver can not allocate the memory required for execution or completion of the function.
HY008	Operation canceled	<p>Asynchronous processing for StatementHandle is available and SQLCancel or SQLCancelHandle is called on StatementHandle before the function is called and completed. Then this function is called again on StatementHandle.</p> <p>SQLCancel or SQLCancelHandle is called on StatementHandle from other thread in the multithreaded application before the function is called and completed.</p>
HY009	Invalid use of null pointer	<p>TableName argument is the null pointer.</p> <p>The SQL_ATTR_METADATA_ID statement attribute is set to SQL_TRUE, the CatalogName argument is a null pointer, and the SQL_CATALOG_NAME InfoType returns that catalog names are supported.</p> <p>The SQL_ATTR_METADATA_ID statement attribute is set to SQL_TRUE, and the SchemaName argument is a null pointer.</p>
		The asynchronously executing function is called for the connection handle related to StatementHandle, and this function is still being executed when SQLStatistics is called.

SQLSTATE	Error	Description
HY010	Function sequence error	<p>SQLExecute, SQLExecDirect, SQLMoreResults is called for StatementHandle, and SQL_PARAM_DATA_AVAILABLE is returned. The function is called, before the data retrieves all streamed parameters.</p> <p>The asynchronously executing function is called for StatementHandle, and is still being executed when the function is called.</p> <p>SQLExecute, SQLExecDirect, SQLBulkOperation or SQLSetPos are called for StatementHandle, and SQL_NEED_DATA is returned. This function is called before data is sent for all data-at-execution parameters or columns.</p>
HY013	Memory management error	The function is not executed because the underlying memory object cannot be accessed because of the low memory condition.
HY090	Invalid string or buffer length	<p>A name length argument value is smaller than 0, but it is not SQL_NTS.</p> <p>A single value of the name length arguments exceeds the maximum length.</p>
HY100	Uniqueness option type out of range	The invalid unique value is specified.
HY101	Accuracy option type out of range	The invalid reserved value is specified.
HY117	Connection is suspended due to unknown transaction state. Only disconnect and read-only functions are allowed.	For more information about the suspended state, refer to <b>SQLEndTran</b> .
HYC00	Optional feature not implemented	<p>A catalog is specified, and the driver or data source does not support catalogs.</p> <p>A schema is specified, and the driver or data source does not support schemas.</p> <p>A string search pattern is specified, and the catalog name, table schema, table name, data source does not support it.</p> <p>The combination of the current settings of the SQL_ATTR_CONCURRENCY and SQL_ATTR_CURSOR_TYPE statement attributes is not supported by the driver or data source.</p> <p>The SQL_ATTR_USE_BOOKMARKS statement attribute is set to SQL_UB_VARIABLE, and the SQL_ATTR_CURSOR_TYPE statement attribute is</p>

SQLSTATE	Error	Description
		set to a cursor type for which the driver does not support bookmarks.
HYT00	Timeout expired	The query timeout period is expired before the data source returns the requested result. The time limit can be set via SQLSetStmtAttr of SQL_ATTR_CONNECTION_TIMEOUT.
HYT01	Connection timeout expired	The connection timeout period is expired before the data source responds to the request. The connection time limit can be set via SQLSetConnectAttr of SQL_ATTR_CONNECTION_TIMEOUT.
IM001	Driver does not support this function	The driver does not support the function.
IM017	Polling is disabled in a synchronous notification mode	Whenever using the notification model, polling can not be used.
IM018	SQLCompleteAsync has not been called to complete the previous asynchronous operation on this handle.	If the previous function call for the handle returns SQL_STILL_EXECUTING and if the notification mode is activated, then SQLCompleteAsync should be called for the handle to do post processing and complete the operation.

## Description

SQLStatistics returns information of a table as a standard result set sorted by NON\_UNIQUE, TYPE, INDEX\_QUALIFIER, INDEX\_NAME, ORDINAL\_POSITION. The result set combines the table statistics information (CARDINALITY and PAGES row of the result set) along with information for each index. For more information, refer to **Using Catalog Data**.

SQLGetInfo is called with SQL\_MAX\_CATALOG\_NAME\_LEN, SQL\_MAX\_SCHEMA\_NAME\_LEN, SQL\_MAX\_TABLE\_NAME\_LEN, SQL\_MAX\_COLUMN\_NAME\_LEN to determine the actual length of TABLE\_CAT, TABLE\_SCHEM, TABLE\_NAME, COLUMN\_NAME rows in the application.



For more information about the general use, arguments, and returned data of ODBC catalog functions, refer to **Catalog Function**.

The following columns are renamed in ODBC 3.x. Changing column name does not affect the backward compatibility because applications bind by column number.

ODBC 2.0 column	ODBC 3.x column
TABLE_QUALIFIER	TABLE_CAT
TABLE_OWNER	TABLE_SCHEM
SEQ_IN_INDEX	ORDINAL_POSITION
COLLATION	ASC_OR_DESC

The following table lists the columns in the result set. The additional columns beyond the column 13 (FILTER\_CONDITION) can be defined by the driver. The application should count from the end of the result set rather than specifying an explicit position to access the columns defined by the driver. For more information, refer to **Data Returning of Catalog Function**.

Column name	Column number	Data type	Description
TABLE_CAT (ODBC 1.0)	1	Varchar	It is the catalog name. If the data source can not be converted, it is NULL. If the driver does not support the catalog, an empty string ("") is returned and the tables do not have the catalog.
TABLE_SCHEM (ODBC 1.0)	2	Varchar	It is the schema name. If it is not applicable to the data source, it is NULL. If the driver does not support the schema, an empty string ("") is returned and the tables do not have the schema.
TABLE_NAME (ODBC 1.0)	3	Varchar not NULL	It is the table name to which the statistics or index is applied.
NON_UNIQUE (ODBC 1.0)	4	Smallint	It indicates whether the duplication of the index value is allowed. <ul style="list-style-type: none"> <li>SQL_TRUE: The index values may not be unique.</li> <li>SQL_FALSE: The index values should be unique.</li> </ul> If TYPE is SQL_TABLE_STAT, NULL is returned.
INDEX_QUALIFIER (ODBC 1.0)	5	Varchar	It is an identifier which executes DROP INDEX and specifies the index name.  If it is the data source which does not support the index rules or TYPE is SQL_TABLE_STAT, then NULL is returned. If a non-NULL value is returned in the row, the value is used to define the index identified in DROP INDEX. Otherwise, the TABLE_SCHEM should be used to qualify the index name.
INDEX_NAME (ODBC 1.0)	6	Varchar	It is the index name. If TYPE is SQL_TABLE_STAT, NULL is returned.
TYPE (ODBC 1.0)	7	Smallint not NULL	It is the information type to be returned. <ul style="list-style-type: none"> <li>SQL_TABLE_STAT: It indicates statistics for the table. (in CARDINALITY or PAGES row )</li> <li>SQL_INDEX_BTREE: It indicates B-Tree index.</li> <li>SQL_INDEX_CLUSTERED: It indicates the cluster index.</li> <li>SQL_INDEX_CONTENT: It indicates the content of the index.</li> <li>SQL_INDEX_HASHED: It indicates the hash index.</li> <li>SQL_INDEX_OTHER: It indicates other types of index.</li> </ul>
ORDINAL_POSITION (ODBC 1.0)	8	Smallint	It is the row order on the index (starting from 1). If TYPE is SQL_TABLE_STAT, NULL is returned.
COLUMN_NAME			It is the column name. If the row is an expression such as SALARY + BE

Column name	Column number	Data type	Description
AME (ODBC 1.0)	9	Varchar	NEFITS, the expression is returned. If the expression is unknown, an empty string is returned. If TYPE is SQL_TABLE_STAT, NULL is returned.
ASC_OR_DESC (ODBC 1.0)	10	Char(1)	It is the column sorting sequence. A is ascending, and D is descending. If the row sorting sequence is not supported in the data source or TYPE is SQL_TABLE_STAT, then NULL is returned.
CARDINALITY (ODBC 1.0)	11	Integer	The cardinality of the table or index. If TYPE is SQL_TABLE_STAT, it is the number of rows of the table. If TYPE is not SQL_TABLE_STAT, it is the number of unique values of the index. If the value can not be used from the data source, NULL is returned.
PAGES (ODBC 1.0)	12	Integer	It is the number of pages stored in the index or table. If TYPE is SQL_TABLE_STAT, it is the number of pages of the table. If TYPE is not SQL_TABLE_STAT, it is the number of pages of the index. If the value of the data source can not be used or converted, then NULL is returned.
FILTER_CONDITION (ODBC 2.0)	13	Varchar	If the index is the filtered index such as SALARY > 30000, it is the filter condition. If the filter condition can not be determined, it is an empty string. If it is not an index, the filtered index can not be determined or TYPE is SQL_TABLE_STAT.

If the row in the result set corresponds to the table, the driver sets TYPE to SQL\_TABLE\_STAT, and sets NON\_UNIQUE, INDEX\_QUALIFIER, INDEX\_NAME, ORDINAL\_POSITION, COLUMN and ASC\_OR\_DESC to NULL. If CARDINALITY or PAGES can not be used in the data source, the driver sets them to NULL.



# SQLTablePrivileges

## Conformance

Introduced version: ODBC 1.0

Standards compliance: ODBC

## Overview

SQLTablePrivileges returns the table list and the privileges related to each table. The driver returns the information in the form of the result set in the specified statement.

## Syntax

```
SQLRETURN SQLTablePrivileges(  
    SQLHSTMT      StatementHandle,  
    SQLCHAR *     CatalogName,  
    SQLSMALLINT   NameLength1,  
    SQLCHAR *     SchemaName,  
    SQLSMALLINT   NameLength2,  
    SQLCHAR *     TableName,  
    SQLSMALLINT   NameLength3);
```

## Arguments

### StatementHandle

[Input] It is the statement handle for the search results.

### CatalogName

[Input] It is the table catalog. If the driver does not support the catalog, an empty string ("" ) is returned and the tables do not have a catalog. The catalog name can not include a string search pattern .

If SQL\_ATTR\_METADATA\_ID is set to SQL\_TRUE, CatalogName is treated as an identifier and it is not case-sensitive. If it is set to SQL\_FALSE, CatalogName is treated as an ordinary argument, it is treated literally, and it is case-sensitive. For more information, refer to **Arguments of Catalog Function**.

### NameLength1

[Input] It is the string length of \*CatalogName.

**SchemaName**

[Input] It is a string search pattern for the schema name. If the driver does not support the schema, an empty string ("") is returned and the tables do not have a schema.

If SQL\_ATTR\_METADATA\_ID is set to SQL\_TRUE, SchemaName is treated as an identifier and it is not case-sensitive. If it is set to SQL\_FALSE, SchemaName is treated as a pattern value string argument and it is case-sensitive.

**NameLength2**

[Input] It is the string length of \*SchemaName.

**TableName**

[Input] It is table name string search pattern .

If SQL\_ATTR\_METADATA\_ID is set to SQL\_TRUE, TableName is treated as an identifier and it is not case-sensitive. If it is set to SQL\_FALSE, TableName is treated as a pattern value string argument and it is case-sensitive.

**NameLength3**

[Input] It is the string length of \*TableName.

**Returns**

SQL\_SUCCESS, SQL\_SUCCESS\_WITH\_INFO, SQL\_STILL\_EXECUTING, SQL\_ERROR, SQL\_INVALID\_HANDLE

**Diagnosis**

SQLSTATE	Error	Description
01000	General warning	It is the driver-specific informational message. (The function returns SQL_SUCCESS_WITH_INFO.)
08S01	Communication link failure	Before the function processing is completed, the connection between the driver and the data source is failed.
24000	Invalid cursor state	A cursor is open on the StatementHandle, and SQLFetch or SQLFetchScroll had been called.  This error is returned by the driver manager if SQLFetch or SQLFetchScroll does not return SQL_NO_DATA, and is returned by the driver if SQLFetch or SQLFetchScroll returns SQL_NO_DATA.  A cursor is open on the StatementHandle, but SQLFetch or SQLFetchScroll is not called.
40001	Serialization failure	The transaction is rolled back due to a resource deadlock of other transactions.
40003	Statement completion unknown	The related connection fails during the function execution and the status of the transaction is not able to be checked.

SQLSTATE	Error	Description
HY000	General error	It is an error without specific SQLSTATE, and the error message returned by SQLGetDiagRec in *MessageText buffer describes error message and its cause.
HY001	Memory allocation error	The driver can not allocate the memory required for execution or completion of the function.
HY008	Operation canceled	Asynchronous processing for StatementHandle is available and SQLCancel or SQLCancelHandle is called on StatementHandle before the function is called and completed. Then this function is called again on StatementHandle.  SQLCancel or SQLCancelHandle is called on StatementHandle from other thread in the multithreaded application before the function is called and completed.
HY009	Invalid use of null pointer	SQL_ATTR_METADATA_ID statement attribute is set to SQL_TRUE, and CatalogName argument is a null pointer. SQL_CATALOG_NAME InfoType returns that catalog names are supported.  SQL_ATTR_METADATA_ID statement attribute is set to SQL_TRUE, and SchemaName or TableName argument is a null pointer.
HY010	Function sequence error	The asynchronously executing function is called for the connection handle related to StatementHandle, and this function is still being executed when SQLTablePrivileges is called.  SQLExecute, SQLExecDirect or SQLMoreResults are called for StatementHandle, and SQL_PARAM_DATA_AVAILABLE is returned. This function is called before data is retrieved for all streamed parameters.  The asynchronously executing function is called for StatementHandle, and is still being executed when the function is called.  SQLExecute, SQLExecDirect, SQLBulkOperation or SQLSetPos are called for StatementHandle, and SQL_NEED_DATA is returned. This function is called before data is sent for all data-at-execution parameters or columns.
HY013	Memory management error	The function is not executed because the underlying memory object can not be accessed because of the low memory condition.
HY090	Invalid string or buffer length	The value of a length arguments is smaller than 0 but it is not SQL_NTS.  The value of a length arguments exceeds the maximum length value for the corresponding name.
HY117	Connection is suspended due to unknown transaction state. Only	For more information about the suspended state, refer to <b>SQLEndTran</b> .

SQLSTATE	Error	Description
	disconnect and read-only functions are allowed.	
HYC00	Optional feature not implemented	<p>A catalog is specified, and the driver or data source does not support catalogs.</p> <p>A schema is specified, and the driver or data source does not support schemas.</p> <p>A string search pattern is specified, and the catalog name, table schema, table name, data source does not support it.</p> <p>The combination of the current settings of the SQL_ATTR_CONCURRENCY and SQL_ATTR_CURSOR_TYPE statement attributes is not supported by the driver or data source.</p> <p>The SQL_ATTR_USE_BOOKMARKS statement attribute is set to SQL_UB_VARIABLE, and the SQL_ATTR_CURSOR_TYPE statement attribute is set to a cursor type for which the driver does not support bookmarks.</p>
HYT00	Timeout expired	The query timeout period is expired before the data source returns the requested result. The time limit can be set via SQLSetStmtAttr of SQL_ATTR_CONNECTION_TIMEOUT.
HYT01	Connection timeout expired	The connection timeout period is expired before the data source responds to the request. The connection time limit can be set via SQLSetConnectAttr of SQL_ATTR_CONNECTION_TIMEOUT.
IM001	Driver does not support this function	The driver does not support the function.
IM017	Polling is disabled in a synchronous notification mode	Whenever using the notification model, polling can not be used.
IM018	SQLCompleteAsync has not been called to complete the previous asynchronous operation on this handle.	If the previous function call for the handle returns SQL_STILL_EXECUTING and if the notification mode is activated, then SQLCompleteAsync should be called for the handle to do post processing and complete the operation.

## Description

SchemaName and TableName arguments accept search patterns. For more information about valid search patterns, refer to **Pattern Value Argument**.

SQLTablePrivileges returns the result as a standard result set sorted by TABLE\_CAT, TABLE\_SCHEM, TABLE\_NAME, PRIVILEGE, GRANTEE.

SQLGetInfo function is called with SQL\_MAX\_CATALOG\_NAME\_LEN, SQL\_MAX\_SCHEMA\_NAME\_LEN, SQL\_MAX\_TABLE\_NAME\_LEN to determine the actual length of TABLE\_CAT, TABLE\_SCHEM, TABLE\_NAME columns in the application.



For more information about the general use, arguments, and returned data of ODBC catalog functions, refer to **Catalog Function**.

The following columns are renamed in ODBC 3.x. Changing column name does not affect the backward compatibility because applications bind by column number.

ODBC 2.0 column	ODBC 3.x column
TABLE_QUALIFIER	TABLE_CAT
TABLE_OWNER	TABLE_SCHEM

The following table lists the columns in the result set. The additional columns beyond the column 7 (IS\_GRANTABLE) can be defined by the driver. The application should count from the end of the result set rather than specifying an explicit position to access the columns defined by the driver. For more information, refer to **Data Returning of Catalog Function**.

Column name	Column number	Data type	Description
TABLE_CAT (ODBC 1.0)	1	Varchar	It is the catalog name. If the data source can not be converted, it is NULL. If the driver does not support the catalog, an empty string ("") is returned and the tables do not have the catalog.
TABLE_SCHEM (ODBC 1.0)	2	Varchar	It is the schema name. If it is not applicable to the data source, it is NULL. If the driver does not support the schema, an empty string ("") is returned and the tables do not have the schema.
TABLE_NAME (ODBC 1.0)	3	Varchar not NULL	It is the table name.
GRANTOR (ODBC 1.0)	4	Varchar	It is the user name who grants the privilege. If it is not applicable to the data source, it is NULL.  For all rows in which the value in the GRANTEE column is the owner of the object, the GRANTOR column is _SYSTEM.
GRANTEE (ODBC 1.0)	5	Varchar not NULL	It is the user name to whom the privilege is granted.
			The table privilege. It is one of the followings or the a data source-specific privilege. <ul style="list-style-type: none"> <li>• SELECT: Grantee is allowed to retrieve one or more columns in a table.</li> </ul>

Column name	Column number	Data type	Description
PRIVILEGE (ODBC 1.0)	6	Varchar not NULL	<ul style="list-style-type: none"> <li>• INSERT: Grantee is allowed to insert new rows containing data for one or more columns into a table.</li> <li>• UPDATE: Grantee is allowed to update one or more columns in a table.</li> <li>• DELETE: Grantee is allowed to delete the data of a table.</li> <li>• REFERENCES: Grantee is allowed to refer to one or more columns in a table within constraints. (e.g. unique, referential, Table constraints check)</li> </ul> <p>The scope of action allowed to grantee who is given the table privilege depends on the data source. For example, the UPDATE privilege permits the grantee to update all columns in a table on one data source and only the columns for which the grantor has the UPDATE privilege on another data source.</p>
IS_GRANTABLE (ODBC 1.0)	7	Varchar	<p>It indicates whether GRANTEE can give other user the privilege and it is YES or NO. If it is not applicable to the data source or unknown, it is NULL.</p> <p>The privilege is grantable or not grantable, and it can not be both of them.</p> <p>The result set that SQLColumnPrivileges returns does not include the two rows which all columns except for IS_GRANTABLE have the same value.</p>

# SQLTables

## Conformance

Introduced version: ODBC 1.0

Standards compliance: Open group

## Overview

SQLTables returns the table list, catalog, or schema name, table type stored in the specified data source. The driver returns the information as a result set.

## Syntax

```
SQLRETURN SQLTables(
    SQLHSTMT      StatementHandle,
    SQLCHAR *     CatalogName,
    SQLSMALLINT   NameLength1,
    SQLCHAR *     SchemaName,
    SQLSMALLINT   NameLength2,
    SQLCHAR *     TableName,
    SQLSMALLINT   NameLength3,
    SQLCHAR *     TableType,
    SQLSMALLINT   NameLength4);
```

## Arguments

### StatementHandle

[Input] It is the statement handle for the search results.

### CatalogName

[Input] It is the catalog name. If SQL\_ODBC\_VERSION environment attribute is SQL\_OV\_ODBC3, CatalogName argument accepts a search pattern. If the driver supports catalogs only for a few tables, for example, the driver retrieves the data from another DBMS, an empty string ("") indicates that the table does not have a catalog.

If SQL\_ATTR\_METADATA\_ID statement attribute is set to SQL\_TRUE, CatalogName is treated as an identifier and it is not case-sensitive. If it is set to SQL\_FALSE, CatalogName is a pattern value argument, it is treated literally and it is case-sensitive. For more information, refer to **Arguments of Catalog Function**.

**NameLength1**

[Input] It is the string length of \*CatalogName.

**SchemaName**

[Input] It is the string search pattern for the schema name. An empty string (""), such as CatalogName, indicates that the table does not have schema. The argument processing depends on SQL\_ATTR\_METADATA\_ID statement attribute such as CatalogName.

**NameLength2**

[Input] It is the character length of \*SchemaName.

**TableName**

[Input] It is the string search pattern for the table name. Also, the argument processing depends on SQL\_ATTR\_METADATA\_ID statement attribute such as CatalogName.

**NameLength3**

[Input] It is the character length of \*TableName.

**TableType**

[Input] It is the matched table type list.

SQL\_ATTR\_METADATA\_ID statement attribute does not affect TableType argument. TableType is the value list argument, regardless of setting of SQL\_ATTR\_METADATA\_ID.

**NameLength4**

[Input] It is the character length of \*TableType.

**Returns**

SQL\_SUCCESS, SQL\_SUCCESS\_WITH\_INFO, SQL\_STILL\_EXECUTING, SQL\_ERROR, SQL\_INVALID\_HANDLE

**Diagnosis**

SQLSTATE	Error	Description
01000	General warning	It is the driver-specific informational message. (The function returns SQL_SUCCESS_WITH_INFO.)
08S01	Communication link failure	Before the function processing is completed, the connection between the driver and the data source is failed.
24000	Invalid cursor state	A cursor is open on the StatementHandle, and SQLFetch or SQLFetchScroll had been called.  This error is returned by the Driver Manager if SQLFetch or SQLFetchScroll does not return SQL_NO_DATA, and is returned by the driver if SQLFetch or SQLFetchScroll returns SQL_NO_DATA.  A cursor is open on the StatementHandle, but SQLFetch or SQLFetchSc



SQLSTATE	Error	Description
		roll is not called.
40001	Serialization failure	The transaction is rolled back due to a resource deadlock of other transactions.
40003	Statement completion unknown	The related connection is failed while executing this function, and the state of the transaction cannot be determined.
HY000	General error	It is an error without specific SQLSTATE, and the error message returned by SQLGetDiagRec in *MessageText buffer describes error message and its cause.
HY001	Memory allocation error	The driver can not allocate the required memory for execution or completion of the function.
HY008	Operation canceled	Asynchronous processing for StatementHandle is available and SQLCancel or SQLCancelHandle is called on StatementHandle before the function is called and completed. Then this function is called again on StatementHandle.  SQLCancel or SQLCancelHandle is called on StatementHandle from other thread in the multithreaded application before the function is called and completed.
HY009	Invalid use of null pointer	SQL_ATTR_METADATA_ID statement attribute is set to SQL_TRUE, and CatalogName argument is a null pointer. SQL_CATALOG_NAME InfoType returns that catalog names are supported.  SQL_ATTR_METADATA_ID statement attribute is set to SQL_TRUE, and SchemaName or TableName argument is a null pointer.
HY010	Function sequence error	The asynchronously executing function is called for the connection handle related to StatementHandle, and this function is still being executed when SQLTables is called.  SQLExecute, SQLExecDirect, SQLMoreResults is called for StatementHandle, and SQL_PARAM_DATA_AVAILABLE is returned. The function is called, before the data for all streamed parameters is retrieved.  The asynchronously executing function is called for StatementHandle, and is still being executed when SQLTables function is called.  SQLExecute, SQLExecDirect, SQLBulkOperation or SQLSetPos are called for StatementHandle, and SQL_NEED_DATA is returned. This function is called before data is sent for all data-at-execution parameters or columns.
HY013	Memory management error	The function is not executed because the underlying memory object can not be accessed because of the low memory condition.
HY090	Invalid string or buffer length	The value of a length arguments is smaller than 0 but it is not SQL_NTS.

SQLSTATE	Error	Description
		The value of a length arguments exceeds the maximum length value for the corresponding name.
HY117	Connection is suspended due to unknown transaction state. Only disconnect and read-only functions are allowed	For more information about the suspended state, refer to <i>SQLEndTran</i> .
HYC00	Optional feature not implemented	<p>A catalog is specified, and the driver or data source does not support catalogs.</p> <p>A schema is specified, and the driver or data source does not support schemas.</p> <p>A string search pattern is specified, and the catalog name, table schema, table name, data source does not support it.</p> <p>The combination of the current settings of the <i>SQL_ATTR_CONCURRENCY</i> and <i>SQL_ATTR_CURSOR_TYPE</i> statement attributes is not supported by the driver or data source.</p> <p>The <i>SQL_ATTR_USE_BOOKMARKS</i> statement attribute is set to <i>SQL_UB_VARIABLE</i>, and the <i>SQL_ATTR_CURSOR_TYPE</i> statement attribute is set to a cursor type for which the driver does not support bookmarks.</p>
HYT00	Timeout expired	The query timeout period is expired before the data source returns the requested result. The time limit can be set via <i>SQLSetStmtAttr</i> of <i>SQL_ATTR_CONNECTION_TIMEOUT</i> .
HYT01	Connection timeout expired	The connection timeout period is expired before the data source responds to the request. The connection time limit can be set via <i>SQLSetConnectAttr</i> of <i>SQL_ATTR_CONNECTION_TIMEOUT</i> .
IM001	Driver does not support this function	The driver does not support the function.
IM017	Polling is disabled in a synchronous notification mode	Whenever using the notification model, polling can not be used.
IM018	<i>SQLCompleteAsync</i> has not been called to complete the previous asynchronous operation on this handle.	If the previous function call for the handle returns <i>SQL_STILL_EXECUTING</i> and if the notification mode is activated, then <i>SQLCompleteAsync</i> should be called for the handle to do post processing and complete the operation.

## Description

SQLTables lists all tables in the requested scope. The user may have the SELECT privilege on the tables, or not. The application checks the accessibility as follows.

- SQL\_ACCESSIBLE\_TABLES information type is checked by calling SQLGetInfo.
- The privilege on each table is checked by calling SQLTablePrivileges.

Otherwise, the application should deal with the situation that the user performs a select statement without SELECT privilege.

SchemaName and TableName arguments can use the search pattern. If SQL\_ODBC\_VERSION is SQL\_OV\_ODBC3, then CatalogName argument can also use the search pattern. For more information about valid search pattern, refer to **Pattern Value Argument**.



For more information about the general use, arguments, and returned data of ODBC catalog functions, refer to **Catalog Function**.

The particular meaning of CatalogName, SchemaName, TableName, TableType arguments of SQLTables is defined as follows to support the enumeration of catalog, schema, and table types.

- If CatalogName is SQL\_ALL\_CATALOGS and SchemaName and TableName are the empty string, the result set includes a valid catalog for the data source. (All columns except for TABLE\_CAT column include NULL.)
- If SchemaName is SQL\_ALL\_SCHEMAS and CatalogName and TableName are the empty string, the result set includes a valid schema for the data source. (All columns except for TABLE\_SCHE column include NULL.)
- If TableType is SQL\_ALL\_TABLE\_TYPES and CatalogName, SchemaName, and TableName are the empty string, the result set includes a valid table type for the data source. (All columns except for TABLE\_TYPE column include NULL.)

If TableType is not an empty string, it should include a list of comma-separated values for the types of interest. Each value can be enclosed in single quote (') or unquoted such as 'TABLE', 'VIEW' or TABLE, VIEW. An application should always specify the table type in uppercase. The driver should convert the table type to whatever case is needed by the data source. If the data source does not support the specified table type, SQLTables does not return any data result for that type.

SQLTables returns the result as a standard result set ordered by TABLE\_TYPE, TABLE\_CAT, TABLE\_SCHE, TABLE\_NAME. For more information, refer to **Using Catalog Data**.

SQLGetInfo is called with SQL\_MAX\_CATALOG\_NAME\_LEN, SQL\_MAX\_SCHEMA\_NAME\_LEN, SQL\_MAX\_TABLE\_NAME\_LEN to determine the actual length of TABLE\_CAT, TABLE\_SCHEM, TABLE\_NAME column in the application.

The following columns are renamed in ODBC 3.x. Changing column name does not affect the backward compatibility because applications bind by column number.

ODBC 2.0 column	ODBC 3.x column
TABLE_QUALIFIER	TABLE_CAT
TABLE_OWNER	TABLE_SCHEM

The following table lists the columns in the result set. The additional columns beyond the column 5 (REMARKS) can be defined by the driver. The application should count from the end of the result set rather than specifying an explicit position to access the columns defined by the driver.

For more information, refer to **Data Returning of Catalog Function**.

Column name	Column number	Data type	Description
TABLE_CAT (ODBC 1.0)	1	Varchar	It is the catalog name. If it is not applicable to the data source, it is NULL. If the driver does not support the catalog, an empty string ("") is returned and the tables do not have the catalog.
TABLE_SCHEMA (ODBC 1.0)	2	Varchar	It is the schema name. If it is not applicable to the data source, it is NULL. If the driver does not support the schema, an empty string ("") is returned and the tables do not have the schema.
TABLE_NAME (ODBC 1.0)	3	Varchar	It is the table name.
TABLE_TYPE (ODBC 1.0)	4	Varchar	It is the table type name. It is one of "TABLE", "VIEW", "SYSTEM TABLE", "GLOBAL TEMPORARY", "LOCAL TEMPORARY", "ALIAS", "SYNONYM" or the name specified in the data source.  The meaning of "ALIAS" and "SYNONYM" is driver-specific.
REMARKS (ODBC 1.0)	5	Varchar	It is the description for the table.

# SQLTransact

## Conformance

Introduced version: ODBC 1.0

Standards compliance: It is not available.

## Overview

SQLTransact function in ODBC 2.x is replaced with `SQLEndTran` in ODBC 3.x.

For more information, refer to [SQLEndTran](#).

## 31.6 XA API References

### Overview

X/Open XA is the standards for distributed transaction processing defined in X/Open. Typically, it prescribes the interface between a multi-transaction manager and a local resource manager. XA describes what is needed for the resource manager to process the transaction.

GOLDILOCKS XA is implemented based on X/Open CAE document, Distributed Transaction Processing: The XA Specification (<http://www.opengroup.org/public/catalog/c193.htm>).

X/Open DTP (Distributed Transaction Processing) model defines the transaction management between different heterogeneous computer databases.

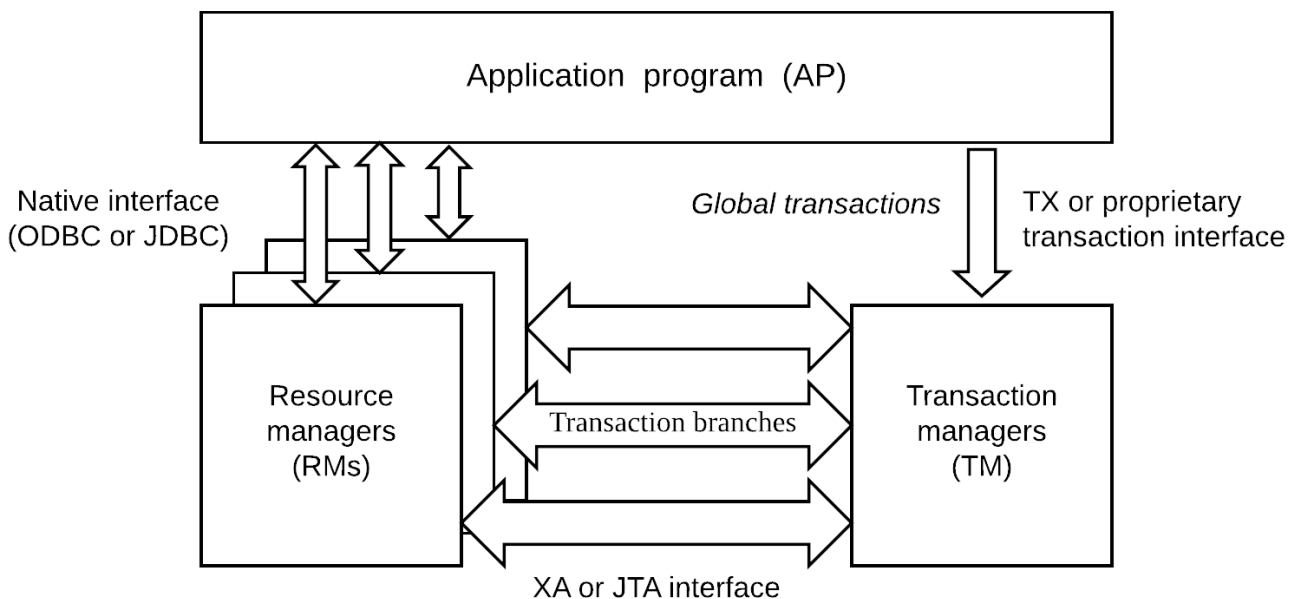

- **Application Program (AP):** It defines the work consisting of transactions.
- **Resource Managers (RM):** It manages the shared resources accessed by a distributed transaction. It means a database management system, such as GOLDILOCKS.
- **Transaction Manager (TM):** It assigns ID(XID) of a distributed transaction, and manages the progress of a distributed transaction, and has the responsibility for the termination and recovery of a distributed transaction.

AP is a program developed by using the precompiler or ODBC. AP does not directly use the XA interface, and it uses the native interface of RM, or it controls the transaction by using TX interface provided by TM.

## XA Interface

XA interface is the interface specification between RM and TM. GOLDILOCKS does not provide a separate library for XA interface, and it is included in the ODBC libraries provided by GOLDILOCKS.

### switch\_t Structure

It is a structure which includes information about the entry point for XA interface and information about RM.

xa\_switch\_t provided by GOLDILOCKS is goldilocks\_xa\_switch.

Variable name	Description
char name[RMNAMESZ]	It is RM name.
long flags	It is the option provided in RM. <ul style="list-style-type: none"> <li>MIGRATE option is not supported. (It is set to TMNOMIGRATE.)</li> </ul>
long version	It is RM version.
int (*xa_open_entry)(char *, int, long);	It is xa_open function pointer.
int (*xa_close_entry)(char *, int, long);	It is xa_close function pointer.
int (*xa_start_entry)(XID *, int, long);	It is xa_start function pointer.
int (*xa_end_entry)(XID *, int, long);	It is xa_end function pointer.
int (*xa_rollback_entry)(XID *, int, long);	It is xa_rollback function pointer.
int (*xa_prepare_entry)(XID *, int, long);	It is xa_prepare function pointer.
int (*xa_commit_entry)(XID *, int, long);	It is xa_commit function pointer.
xint (*xa_recover_entry)(XID *, long, int, long);	It is xa_recover function pointer.
int (*xa_forget_entry)(XID *, int, long);	It is xa_forget function pointer.
int (*xa_complete_entry)(int *, int *, int, long);	It is xa_complete function pointer. <ul style="list-style-type: none"> <li>It is not provided in GOLDILOCKS.</li> </ul>

## ODBC Functions Related to XA

It describes the functions which are added to use the XA interface besides the standard ODBC.

### SQLGetXaSwitch

It gets xa\_switch\_t provided by ODBC function.

```
xa_switch_t * SQLGetXaSwitch( void );
```

#### Return

It returns a pointer to sw\_switch\_t structure provided by ODBC. NULL can not be returned.

### SQLGetXaConnectionHandle

It gets the connection handle related to the current XA session.

```
SQLHANDLE SQLGetXaConnectionHandle( void );
```

#### Return

If the connected XA session exist at the corresponding thread, it returns the related connection handle. Otherwise, it returns NULL.



## XA Functions

It describes the details for XA related functions of `xa_switch_t` structure.

### `xa_open`

It connects to RM.



It is ignored if it is already connected in the thread which called `xa_open`.

```
int xa_open(
    char * xa_info,
    int    rmid,
    long   flags );
```

### Arguments

#### `xa_info`

[Input] It is a string which includes the access information, and the maximum length is 256 bytes. For more information, refer to `InConnectionString` of `SQLDriverConnect`.

#### `rmid`

[Input] It is the unique ID of RM to be connected. The argument is ignored.

#### `flags`

[Input] It is connection flag. It should be set to `TMNOFLAGS`.

### Diagnosis

Return value	Description
<code>XA_OK</code>	The operation is normally performed.
<code>XAER_RMFAIL</code>	It occurs when RM can not be used.
<code>XAER_RMERR</code>	RM can not perform the operation in a transaction branch due to lack of resources.
<code>XAER_INVAL</code>	It occurs when passing the abnormal argument.

## xa\_close

It terminates the connection of RM, and releases the connection handle.

```
int xa_close(  
    char * xa_info,  
    int    rmid,  
    long   flags );
```

### Arguments

#### xa\_info

[Input] It is a string which includes the access information, and the argument is ignored.

#### rmid

[Input] It is the unique ID of RM to be connected. The argument is ignored.

#### flags

[Input] It is the termination flag. The argument is ignored.

### Diagnosis

Return value	Description
XA_OK	The operation is normally performed.
XAER_RMFAIL	It occurs when RM can not be used.
XAER_RMERR	RM can not perform the operation in a transaction branch due to lack of resources.
XAER_INVAL	It occurs when passing the abnormal argument.

## xa\_start

It creates a new transaction branch or starts the existing transaction branch.

```
int xa_start(
    XID *  xid,
    int   rmid,
    long  flags );
```

### Arguments

#### xid

[Input] It is the transaction ID to be started.

#### rmid

[Input] It is the unique ID of RM to be connected. The argument is ignored.

#### flags

[Input] It is the start flag.

flags can use the following values.

- **TMASYNC**: It starts a transaction branch in asynchronous mode. (It is not supported.)
- **TMNOFLAGS**: FLAG is not used and the appropriate flag should be specified if flag is not used.
- **TMNOWAIT**: If the specified transaction branch is used by another session, XA\_RETRY error is returned without waiting.
- **TMRESUME**: The previously suspended transaction branch is continued. It can not be used with TMJOIN.
- **TMJOIN**: It is connected to an existing transaction branch. It can not be used with TMRESUME.

### Diagnosis

Return value	Description
XA_OK	The operation is normally performed.
XAER_RMFAIL	It occurs when the session in use is abnormally terminated.
XAER_RMERR	RM can not perform the operation in a transaction branch due to lack of resources.
XAER_PROTO	It occurs when the execution order does not fit into XA protocol.
XAER_INVAL	It occurs when passing the abnormal argument.
XAER_DUPID	The transaction branch with the same XID already exists.
XAER_NOTA	The transaction branch specified as XID does not exist. It may occur when TMRESUME or TMJOIN is used.
XA_RETRY	It occurs when the specified transaction branch is already used by another session. It may occur when using TMNOWAIT.
XAER_OUTSIDE	The local transaction is already in progress in the session.

Return value	Description
XA_RBROLLBACK	The transaction branch is set to rollback-only.

## xa\_end

It terminates the transaction branch operation.

```
int xa_end(
    XID *  xid,
    int   rmid,
    long  flags );
```

### Arguments

#### xid

[Input] It is the transaction ID to be terminated.

#### rmid

[Input] It is the unique ID of RM to be connected. The argument is ignored.

#### flags

[Input] It is the job termination flag.

flags can use the following values.

- **TMFAIL:** It indicates that the operation failed. It can not be used with TMSUSPEND or TMSUCCESS, and it changes the status of the transaction branch to rollback-only.
- **TMMIGRATE:** It is restarted in connection with another branch. (It is not supported.)
- **TMSUCCESS:** It indicates that the operation is successfully terminated. It can not be used with TMSUSPEND or TMFAIL.
- **TMSUSPEND:** The transaction branch is suspended and terminated.

### Diagnosis

Return value	Description
XA_OK	The operation is normally performed.
XAER_RMFAIL	It occurs when the session in use is abnormally terminated.
XAER_RMERR	RM can not perform the operation in a transaction branch due to lack of resources.
XA_NOMIGRATE	MIGRATE flag is not supported.
XAER_PROTO	It occurs when the execution order does not fit into XA protocol.
XAER_INVALID	It occurs when passing the abnormal argument.
XAER_NOTA	The transaction branch specified as XID does not exist.

## xa\_prepare

It prepares to commit the transactions corresponding to XID. It is the first phase of Two-phase Commit Protocol (2PC).

```
int xa_prepare(
    XID * xid,
    int rmid,
    long flags );
```

### Arguments

#### xid

[Input] It is the transaction ID to be prepared.

#### rmid

[Input] It is the unique ID of RM to be connected. The argument is ignored.

#### flags

[Input] It is the prepare flag. TMNOFLAGS should be set.

### Diagnosis

Return value	Description
XA_OK	The operation is normally performed.
XAER_RMFAIL	It occurs when the session in use is abnormally terminated.
XAER_RMERR	RM can not perform the operation in a transaction branch due to lack of resources.
XA_PROTO	It occurs when the execution order does not fit into XA protocol.
XA_RDONLY	The transaction branch is the read-only transaction.
XAER_NOTA	The transaction branch specified as XID does not exist.
XA_RBROLLBACK	The transaction branch is set to rollback-only.

## xa\_commit

It commits the transactions corresponding to XID. It is the second phase of Two-phase Commit Protocol (2PC).

```
int xa_commit(
    XID * xid,
    int rmid,
    long flags );
```

### Arguments

#### xid

[Input] It is the transaction ID to be committed.

#### rmid

[Input] It is the unique ID of RM to be connected. The argument is ignored.

#### flags

[Input] It is the commit flag.

flags can use the following values.

- **TMNOFLAGS**: It means that FLAG is not used, and if any flag is not used, the appropriate flag should be specified.
- **TMONEPHASE**: It performs One Phase Commit (1PC).

### Diagnosis

Return value	Description
XA_OK	The operation is normally performed.
XAER_RMFAIL	It occurs when the session in use is abnormally terminated.
XAER_RMERR	RM can not perform the operation in a transaction branch due to lack of resources.
XA_PROTO	It occurs when the execution order does not fit into XA protocol.
XA_RDONLY	The transaction branch is the read-only transaction.
XAER_NOTA	The transaction branch specified as XID does not exist.
XA_RBROLLBACK	The transaction branch is set to rollback-only.

## xa\_rollback

It rolls back the transaction corresponding to XID.

```
int xa_rollback(  
    XID *  xid,  
    int   rmid,  
    long  flags );
```

### Arguments

#### xid

[Input] It is the transaction ID to be rolled back.

#### rmid

[Input] It is the unique ID of RM to be connected. The argument is ignored.

#### flags

[Input] It is rollback flag. TMNOFLAGS should be set.

### Diagnosis

Return value	Description
XA_OK	The operation is normally performed.
XAER_RMFAIL	It occurs when the session in use is abnormally terminated.
XAER_RMERR	RM can not perform the operation in a transaction branch due to lack of resources.
XA_HEURRB	The transaction branch is already rolled back heuristically. (heuristic rollback)
XA_HEURCOM	The transaction branch is already committed heuristically. (heuristic commit)
XAER_NOTA	The transaction branch specified as XID does not exist.



## xa\_recover

It gets a list of transactions which are heuristically committed or rolled back.

```
int xa_recover(
    XID * xids,
    long count,
    int rmid,
    long flags );
```

### Arguments

#### xids

[Output] It is the list of transactions which are heuristically committed or rolled back.

#### count

[Input] It refers to the array size of xids.

#### rmid

[Input] It is the unique ID of RM to be connected. The argument is ignored.

#### flags

[Input] It is the recover flag.

flags can use the following values.

- TMSTARTSCAN: It starts to scan, or it starts again from the beginning.
- TMENDSCAN: It terminates the scan.
- TMNOFLAGS: If it is used after TMSTARTSCAN, the following list is obtained. XA\_PROTO error occurs if TMNOFLAGS is used from the beginning.

### Diagnosis

Return value	Description
>= 0	It is the number of returned XIDs. (The array size that is valid in xids.)
XAER_RMFAIL	It occurs when the session in use is abnormally terminated.
XAER_RMERR	RM can not perform the operation in a transaction branch due to lack of resources.
XA_PROTO	It occurs when the execution order does not fit into XA protocol.

## xa\_forget

It deletes the information about transactions which are heuristically committed or rolled back.

```
int xa_forget(
    XID *  xid,
    int   rmid,
    long  flags );
```

### Arguments

#### xid

[Input] It is the transaction ID to be deleted.

#### rmid

[Input] It is the unique ID of RM to be connected. The argument is ignored.

#### flags

[Input] It is the delete flag. TMNOFLAGS should be set.

### Diagnosis

Return value	Description
XA_OK	The operation is normally performed.
XAER_RMFAIL	It occurs when the session in use is abnormally terminated.
XAER_RMERR	RM can not perform the operation in a transaction branch due to lack of resources.
XAER_PROTO	It occurs when the execution order does not fit into XA protocol.
XAER_INVALID	It occurs when passing the abnormal argument.
XAER_NOTA	The transaction branch specified by XID does not exist.

## Example

The following is a simple example of connecting to GOLDILOCKS and performing Two-phase Commit after inserting/ retrieving/ updating/ deleting the record. The complete code for the following example is in \$GOLDILOCKS\_HOME/sample/ODBC/SAMPLE\_XA.c.

1. SQLGetXaSwitch()  
Obtain xa switch\_t structure for using XA interface.
2. SQLAllocHandle()  
Obtain ODBC environment handle.



- SQLSetEnvAttr sets attributes which govern aspects of environments.

```
GOLDILOCKS_SQL_TRY( SQLSetEnvAttr( sEnv,
                                SQL_ATTR_ODBC_VERSION,
                                (SQLPOINTER)SQL_OV_ODBC3,
                                0 ) );

if( (sXaSwitch->xa_open_entry)(
    "DSN=GOLDILOCKS;UID=test;PWD=test",
    0,
    TMNOFLAGS ) != XA_OK )
{
    GOLDILOCKS_SQL_THROW( GOLDILOCKS_FINISH_LABEL );
}
sState = 2;
sDbc = SQLGetXaConnectionHandle();
sXid.formatID = 0;
sXid.gtrid_length = 2;
sXid.bqual_length = 1;
memcpy( sXid.data,
        "100",
        sXid.gtrid_length + sXid.bqual_length );

if( (sXaSwitch->xa_start_entry)( &sXid, 0, TMNOFLAGS ) != XA_OK )
{
    GOLDILOCKS_SQL_THROW( GOLDILOCKS_FINISH_LABEL );
}
```

- If SQL\_SUCCESS which is an insert function succeeds

```
GOLDILOCKS_SQL_TRY( testInsert( sDbc ) );
```

- If SQL\_SUCCESS which is a select function succeeds

```
GOLDILOCKS_SQL_TRY( testSelect( sDbc ) );
```

- If SQL\_SUCCESS which is an update function succeeds

```
GOLDILOCKS_SQL_TRY( testUpdate( sDbc ) );
```

- If SQL\_SUCCESS which is a delete function succeeds

```

GOLDILOCKS_SQL_TRY( testDelete( sDbc ) );

    if( (sXaSwitch->xa_end_entry)( &sXid, 0, TMSUCCESS ) != XA_OK )
    {
        GOLDILOCKS_SQL_THROW( GOLDILOCKS_FINISH_LABEL );
    }

    if( (sXaSwitch->xa_prepare_entry)( &sXid, 0, TMNOFLAGS ) != XA_OK )
    {
        GOLDILOCKS_SQL_THROW( GOLDILOCKS_FINISH_LABEL );
    }

    if( (sXaSwitch->xa_commit_entry)( &sXid, 0, TMNOFLAGS ) != XA_OK )
    {
        GOLDILOCKS_SQL_THROW( GOLDILOCKS_FINISH_LABEL );
    }

    sState = 1;
    if( (sXaSwitch->xa_close_entry)( "", 0, TMNOFLAGS ) != XA_OK )
    {
        GOLDILOCKS_SQL_THROW( GOLDILOCKS_FINISH_LABEL );
    }
    sDbc = NULL;

```

- SQLFreeHandleEnv releases resources which are related to an environment.

```

sState = 0;
    GOLDILOCKS_SQL_TRY( SQLFreeHandle( SQL_HANDLE_ENV,
                                       sEnv ) );

    sEnv = NULL;
    return EXIT_SUCCESS;
GOLDILOCKS_FINISH;
    if( sDbc != NULL )
    {
        PrintDiagnosticRecord( SQL_HANDLE_DBC, sDbc );
    }
    if( sEnv != NULL )
    {
        PrintDiagnosticRecord( SQL_HANDLE_ENV, sEnv );
    }
    switch( sState )

```

```
{
```

- Case 2: SQLDisconnect closes the connection which is related to a specific connection handle.

```
(void)(sXaSwitch->xa_close_entry)( "", 0, TMNOFLAGS );
```

- Case 1: SQLFreeHandleEnv releases resources which are related to an environment.

```
(void)SQLFreeHandle( SQL_HANDLE_ENV, sEnv );  
    sEnv = NULL;  
    default:  
        break;  
}  
return EXIT_FAILURE;  
}
```

**32.**

---

**JDBC**

## 32.1 Overview of GOLDBLOCKS JDBC Driver

### Concepts of GOLDBLOCKS JDBC Driver

GOLDBLOCKS provides GOLDBLOCKS JDBC driver (excluding some features) which complies with standard JDBC 4.0 based on TCP/IP connection. The user can use various transaction features and data query features by using GOLDBLOCKS JDBC driver and connecting to GOLDBLOCKS in Java program. GOLDBLOCKS JDBC driver is written and built based on JDK 1.6. Therefore, it supports JDBC 4.0 features. The driver can be used by adding `$GOLDBLOCKS_HOME/lib/goldlocks6.jar` file to the class path.

The number after goldlocks refers to the JDK version. For more information, refer to **Supporting Versions**.

GOLDBLOCKS JDBC complies with most of JDBC standard specifications, and it also supports non-standard API methods and classes to provide some unique features. For more information about non-standard methods, refer to each class API of **JDBC API References** or **Using Other Data Types**.

### Characteristics

- **Type-4 JDBC Driver**

GOLDBLOCKS JDBC is a JDBC Type-4 type which is implemented only with pure Java. A user can use a JDBC driver only with jar file without any additional libraries. Also, it is faster and reliable than JDBC-ODBC Bridge type, and it has better portability than Type-2 using Native API.

- **JDBC Standard Compliance**

GOLDBLOCKS JDBC can recycle most of other existing JDBC programs without changing because it complies with the JDBC standard. The connection, various statements and ResultSet features can be used without modifying. However, the connection URL and property name, the name of driver class to be loaded should be changed to suit GOLDBLOCKS. And the non-standard features and types are usable with the separate classes and methods API.

- **Supporting Various Java Versions**

GOLDBLOCKS JDBC driver supports three files such as `goldlocks8.jar`, `goldlocks7.jar`, `goldlocks6.jar`, so that a user can select and use the file appropriate for user's Java run-time environment. Because each jar file was built based on JDK 1.8, JDK 1.7, JDK 1.6, it complies with each JDBC 4.2, JDBC 4.1, JDBC 4.0 specifications.



- **Flexible Version Compatibility with the Server**

Refer to the protocol version for the compatibility with the server and the JDBC driver. If the protocol version of server is higher than that of the JDBC driver, it can be connected.

- **API Support for Connection Pooling**

JDBC connection object is a resource which is expensive to generate. Therefore, the JDBC standard define a pooling system for it, and `ConnectionPoolDataSource` and `PooledConnection` are its interfaces. GOLDILOCKS JDBC implements these interfaces and provides the pooling facility in third party middleware products.

- **Supporting XA API**

A user can perform the global transaction work by implementing XA interface which is the global transaction standard. And a user can perform the various XA features complying with a standard by using `XAResource` which is JDBC interface.

- **GOLDILOCKS-specific Data Type**

GOLDILOCKS uses the data types which are not provided by the JDBC standard. For example, they are Interval related type, the type with time zone information such as Timestamp with time zone, etc. The driver provides a way to obtain or insert these types to DB.

- **Server-based Powerful Cursor Scroll Feature**

Other JDBC drivers cache the row set in the driver for `ResultSet` scroll, so uses excessively memory of a client application program. For example, if the cursor is open by scroll insensitive and the rows are patched up to the last, all rows are cached in the driver, and the entire table resides in the client memory. It causes the out of memory error and the excessive use of client memory resource.

However, GOLDILOCKS supports the cursor scroll feature within the server, and clients may have lightweight, fast and reliable performance.

- **Efficient Use of Resources**

Because GOLDILOCKS minimizes the memory which maintains the row information compared to other JDBC drivers and it does not use Java objects as possible. It can avoid the excessive garbage collection, and perform fast and reliable table scanning with less memory.

- **Accurate and Extensive Metadata**

Because `DatabaseMetaData` interface of JDBC standard is faithfully and accurately implemented, it is easy to be linked with various DB tools. In addition, the usability is increased by retrieving DB meta information through various system views.

- **Powerful Logging**

Various logging features are provided to monitor the usual JDBC API calls and network usage as well as the problem. If the logging-related features are specified in the connection URL, a user can leave a content log to the console or files. Four types of logging exist, which are logging for JDBC method call recording, logging for protocol sending and receiving, logging for the SQL statement used, logging for global connection usage.

- **Connection Failover**

Connection failover is supported on JDBC driver level to continuously use an existing connection by automatically reconnecting to the previously registered alternate server when the connection with the execution on GOLDILOCKS server fails or is disconnected. A user can use connection failover feature as an existing JDBC program without any exception handling in preparation for the broken connection.

- **Connectivity between server and direct attach**

Other than TCP/IP based connection, it can be connected with direct attach method interworking with a process as same as the server. Like as ODBC connection supports direct attach method and Client/Server method, GOLDILOCKS JDBC driver also provides both methods. JDBC program connected with direct attach does not communicate with TCP/IP, but it can use the server features in jvm by directly interworking with the server process. The performance is doubled or more than the JDBC program connected with TCP/IP.

## Supporting Versions

### GOLDILOCKS JDBC versions

GOLDILOCKS JDBC version information can be viewed when executing goldilocks6.jar file as follows.

```
shell>java -jar goldilocks6.jar
GOLDILOCKS JDBC Driver 1.1 Protocol-2.5.2, JDBC4.0 compiled with JDK1.6
```

The examples above describe that current GOLDILOCKS JDBC driver version is 1.1, and the protocol version is 2.5.2, and JDBC standard version is 4.0 and it is built in JDK 1.6. The driver version is displayed apart from GOLDILOCKS product version, and it goes up whenever the function is strengthened. For more information about JDBC driver version, refer to **getDriverMajorVersion**, **getDriverMinorVersion**, **getDriverVersion** of DatabaseMetaData.

Protocol version determines compatibility with the server, and the driver can interwork with the server if the version is equal to or lower than the server protocol version. The server supports all clients API of the lower protocol version.

goldilocks6.jar complies with JDBC 4.0 standard and it was built in JDK 1.6. goldilocks7.jar complies with JDBC 4.1 standard and it was built in JDK 1.7. goldilocks8.jar complies with JDBC 4.2 standard and it was built in JDK 1.8. Therefore, if the user's java environment is higher than JDK 1.8, use goldilocks8.jar. However, when using Java JDK 1.9 or higher, goldilocks8.jar can be used but API or classes of JDBC 4.3 can not be used.

## Examples

### Setting Class Path

CLASSPATH should be set to use GOLDBLOCKS JDBC driver.

```
export CLASSPATH=.:$GOLDBLOCKS_HOME/lib/goldilocks6.jar
```

Or, add a suitable jar file for the user's Java execution environment to the path.

### Loading Driver Class

The driver class can be loaded as follows.

```
Class.forName("sunje.goldilocks.jdbc.GoldilocksDriver");
```

The example above is the conventional method of using JDBC, and it is the method of dynamically loading the driver class and registering in DriverManager and getting the connection. Nowadays, the way to get the connection through DataSource is used more. For more information, refer to the corresponding class in [JDBC API References](#).

### Getting Connection

The following code is used to get the connection.

```
Connection con = DriverManager.getConnection(
    "jdbc:goldilocks://127.0.0.1:22581/test", "TEST", "test");
```

The connection URL should be started with "jdbc:goldilocks:" to use GOLDBLOCKS JDBC. The next is the IP address and port number of the server and "/test" which is the final part of URL is the DB name. The current GOLDBLOCKS does not specifically check the DB name because it does not support multi DB. A user connected URL may be obtained again through DatabaseMetaData.getURL().

It connects in Direct Attach (D/A) mode when setting IP to 0.0.0.0, and a port to 0. Or, the connecting protocol, *da*, can be used instead of ip:port. In other words, both of the following two URL enables connect

ing in DA mode.

```
"jdbc:goldilocks://0.0.0.0:0/test"  
"jdbc:goldilocks:da/test"
```

Username and password should respectively use the account and password for DB.

## Using Statement and ResultSet

Statement and ResultSet are used in the same way as other JDBC programs.

```
Statement stmt = con.createStatement();  
ResultSet rs = stmt.executeQuery("SELECT NAME, ADDRESS FROM EMP");  
while (rs.next())  
{  
    System.out.println("name = " + rs.getString(1));  
    System.out.println("address = " + rs.getString(2));  
}  
rs.close();  
stmt.close();
```

## 32.2 Feature Specification

### Connection

#### Connection Using DriverManager

The traditional way to get a connection is to use DriverManager.

```
Connection con = DriverManager.getConnection(url_string, user_name, password);
```

url\_string has the following three types.

```
jdbc:goldilocks://[ip address]:[port_no]/[db_name]
```

```
jdbc:goldilocks:da/[db_name]
```

```
jdbc:goldilocks:locator//[ip address]:[port_no][, [ip address]:[port_no] ]*/[db_name]
```

The host name, IPv4 and IPv6 are available for IP address, and port\_no refers to the port number set. db\_name is not used for the current connection so it can have any name. However, it can not be omitted. The following is an example of URL.

```
String url_string = "jdbc:goldilocks://localhost:22581/test";
```

```
String url_string = "jdbc:goldilocks://127.0.0.1:22581/test";
```

```
String url_string = "jdbc:goldilocks://[::1]:22581/test";
```

IP "0.0.0.0" and port 0 are used as a special address for D/A connection. For more information about D/A mode, refer to **Connecting in Direct Attach Mode**.

user\_name and password refer to GOLDILOCKS account.

The following method is used for various property settings except for the getConnection() method above.

```
Properties prop = new Properties();
prop.setProperty("user", user_name);
prop.setProperty("password", password);
Connection con = DriverManager.getConnection(url_string, prop);
```

A locator keyword can be added to `url_string` to obtain the server connection information from glocator instead of using the connection property. In this case, ip address and port\_no is considered as the connection information of glocator.

The following is an example of using the locator keyword to the connection statement.

```
String url_string =
"jdbc:goldilocks:locator//127.0.0.1:42581,127.0.0.1:42582/test?locator_service=S1";
```

The first connection information (127.0.0.1:42581) is the connection information of glocator, and the later connection information is processed as ALTERNATE\_LOCATORS property such as 127.0.0.1:42582.

The following is the property setting which has the meaning as same as the `url_string` above.

```
String url_strng = "jdbc:goldilocks://0.0.0.0:0/test";
Properties prop = new Properties();
prop.setProperty("locator_host", "127.0.0.1");
prop.setProperty("locator_port", "42581");
prop.setProperty("alternate_locators", "127.0.0.1:42582");
prop.setProperty("locator_service", "S1");
Connection con = DriverManager.getConnection(url_string, prop);
```

The property list which can be used for the connection is known through `getPropertyInfo()` method of `GoldilocksDriver`. For more information, refer to **Table 32-1 Connection property**.

The login timeout of the connection object which is created by `DriverManager` and the logger uses the value registered in `DriverManager`. The logger is used by all JDBC interfaces generated from the connection object. Each connection object is not allowed to have an individual logger.

## Connection Using DataSource

The JDBC standard recommends to use `DataSource` rather than the previous `DriverManager`. It is because `DataSource` is a single interface to access any data source, and it can individually set the values related to the various data sources, and may remotely send a `DataSource` object literally.

A connection object can be obtained through `DataSource` as follows.

```
import sunje.goldilocks.jdbc.GoldilocksDataSource;
GoldilocksDataSource ds = new GoldilocksDataSource();
ds.setServerName("127.0.0.1");
ds.setPortNumber(22581);
ds.setDatabaseName("test");
ds.setUser("TEST");
ds.setPassword("test");
```

```
Connection con = ds.getConnection();
```

GoldilocksDataSource classes should be used to create a DataSource object.

Then, various connection information should use setter method which is not DataSource standard API. For more information, refer to **DataSource**.

When using DriverManager, the login timeout and the logger should be globally set. However, when using DataSource, the login timeout and the logger can be individually set.

```
ds.setLoginTimeout(10);
ds.setLogWriter(out);
```

## Interworking with Middleware

It is necessary to know the name of the class which implements XADataSource, ConnectionPoolDataSource interface to interwork with middleware such as Weblogic, JBoss, etc. GOLDILOCKS provides Goldilocks XADataSource, GoldilocksConnectionPoolDataSource for sunje.goldilocks.jdbc package. Both classes offer the various setter methods such as GoldilocksDataSource.

```
import sunje.goldilocks.jdbc.GoldilocksXADataSource;
GoldilocksXADataSource ds = new GoldilocksXADataSource();
ds.setServerName("127.0.0.1");
ds.setPortNumber(22581);
ds.setDatabaseName("test");
ds.setUser("TEST");
ds.setPassword("test");
XAConnection con = ds.getXAConnection();
```

## Connection Property

Table 32-1 Connection property

Name	Mandatory/optional	Valid value	Description
alternate_servers	Optional	IP:PORT[,IP:PORT]+	It is the list of alternate servers for failover. It is delimited by comma (,).
alternate_locations	Optional	IP:PORT[,IP:PORT]+	It is the list of alternate of locator.
batch_count	Optional	Any integer	It is the number of the batch jobs which can be processed in a single protocol transmission and reception. The default value is 1,000. If the value is too small, too much frequent network communication causes poor performance of the batch process.

Name	Mandatory/optional	Valid value	Description
			ng. If the value is too large, the server memory is increased because the session stacks the execution results.
connection_retry_count	Optional	Any integer	It stores the number of retries to connect. The default value is 0, then it does not retry to connect.
connection_retry_delay	Optional	Any integer	It stores the delay before the connection retry in seconds when trying to connect again. The default value is 3.
date_format	Optional	Any string	It is the character format which is used to interconvert between date and string inside the driver.
da_buffer_size	Optional	Any integer	It sets the size of a buffer which sends and receives data when fetching and binding while connected in direct attach mode. The default value is 100000.
decoding_replacement	Optional	Any string	It is the character replacing a byte value which can not be decoded when decoding a byte array into a string. The default value is ?.
failover_granularity	Optional	{"0", "1", "2"}	It determines whether failover is successful. non-atomic(0), atomic(1), 2 are not yet supported. When an error occurs for the existing prepared statements in the prepare process during failover, if it is 0, then it proceeds the failover, and if it is 1, it determines that the failover fails. The default value is 0.
failover_type	Optional	{"connection", "session"}	It determines the failover types. <ul style="list-style-type: none"> <li>• Connection: Failover is used only when connecting to server.</li> <li>• Session: Failover is used when connecting to server as well as communicating with the server like execution.</li> </ul> The default value is session.
format_grammar	Optional	{"db", "java"}	It determines whether the property string such as date_format is the GOLDILOCKS syntax or the syntax used in SimpleDateFormat of java. The default value is db.
global_connection_log	Optional	boolean	It determines whether to perform the global connection logging. The default value is false.
global_logger	Optional	{"console"}	It specifies the logging target. Currently only console is available. Only the first specified one is valid.
home_dir	Optional	Any string	It specifies a home directory of a cluster server. The default value is null.
include_synonyms	Optional	boolean	It sets whether to include the synonym object in DatabaseMetaData.getColumns(). The default value is false.
keep_alive	Optional	boolean	It determines whether to set the keep_alive as the socket property of the connection. Using the property, the connection remains by periodically sending and receiving ack inside TCP socket. LAN cable error detection can forcibly cut off the connecti



Name	Mandatory/optional	Valid value	Description
			on. The default value is false.
locality_aware_transaction	Optional	boolean	It determines whether to use GLOBAL CONNECTION. If it is set to true, then it uses GLOBAL CONNECTION. The default value is false.
locality_group_policy	Optional	{"0", "1", "2"}	It determines how to select a group if neither of groups are available, or two or more groups are available when using GLOBAL CONNECTION. <ul style="list-style-type: none"> <li>• 0: It randomly selects the group.</li> <li>• 1: It sequentially selects groups which exist in LOCALITY_GROUP_PATH setting. If neither of groups in LOCALITY_GROUP_PATH are not available, it randomly selects the group.</li> <li>• 2: It sequentially selects groups. It always selects groups in an order of they are connected to the driver.</li> </ul>
locality_group_path	Optional	Group name list	It defines the list of selected groups when the available group is not a single one when using GLOBAL CONNECTION. Each group is distinguished with comma (.). e.g. G1,G2,G3
locality_member_policy	Optional	{"0","1","2","3","4"}	It determines how to select a member in the selected group when using GLOBAL CONNECTION. <ul style="list-style-type: none"> <li>• 0: DML : MASTER / SELECT : MASTER</li> <li>• 1: DML : ANY / SELECT : ANY</li> <li>• 2: DML : MASTER / SELECT : ANY</li> <li>• 3: DML : MASTER / SELECT : SLAVE</li> <li>• 4: It sequentially selects members which exist in LOCALITY_MEMBER_PATH setting. If neither of members in LOCALITY_MEMBER_PATH are not available, it uses the MASTER in the selected group.</li> </ul>
locality_member_path	Optional	Member name list	It defines the list of members to be used in the selected group when using GLOBAL CONNECTION. Each member is distinguished with comma (.). e.g. G1N1,G2N1,G3N1,G1N2,G2N2,G3N2
locality_on_demand	Optional	boolean	It accesses to a specific member in need when using GLOBAL CONNECTION. The default value is false. <ul style="list-style-type: none"> <li>• false: It accesses to all members from the beginning.</li> <li>• true: It accesses to a specific member when it is required.</li> </ul>
locator_connection_timeout	Optional	Any integer	It is the time of waiting for receiving a packet from glocator.
locator_file	Optional	Any string	It is a location file.
locator_host	Optional	IP address	It is host address of glocator.
locator_port	Optional	Port no	It is port of glocator.

Name	Mandatory/ optional	Valid value	Description
locator_service	Optional	Any string	It is the service name to obtain the server connection information.
login_timeout	Optional	Any integer	It sets the timeout duration (second) of the socket when connecting to the server. The default value is 0, and it indefinitely waits.
lzeros	Optional	Any integer	When a numeric is expressed as a string and the number of zeros following the decimal point exceeds this value, it is expressed in exponent notation. The default value is 15.
new_password	Optional	Any string	It can change the account password by using old_password property together.
old_password	Optional	Any string	It can change the account password by using new_password property together.
packet_compression_threshold	Optional	Any integer	It compresses the communication data to be sent to the server when the data size is bigger than packet_compression_threshold. The property range is 32 ~ 2113929216.
password	Mandatory	Any string	It is user account password.
prefer_ipv6	Optional	boolean	It sets whether IPv6 takes precedence over other IP addresses on the host name. The default value is false.
program	Optional	Any string	It is program description.
protocol_log	Optional	boolean	It determines whether to log sending and receiving a protocol. The default value is false.
query_log	Optional	boolean	It determines whether to log a query. The default value is false.
role	Optional	{"", "SYSDBA", "ADMIN"}	It specifies the account role. The default value is "".
session_type	Optional	{"1", "2", "3"} or {"dedicate", "shared", "default"} }	It is one of dedicated/ shared/ default. (It is selected by DB when it is set to default.)
statement_pool_on	Optional	boolean	It enables the statement pool. The default value is false.
statement_pool_size	Optional	Any integer	It sets the size of the statement pool.
time_format	Optional	Any string	It is the character format which is used to interconvert between time and string inside the driver.
tcp_nodelay	Optional	boolean	It sets TCP_NODELAY(Nagle's Algorithm) property on the socket of the connection. The default value is true.
timestamp_format	Optional	Any string	It is the character format which is used to interconvert between timestamp and string inside the driver.
time_with_time	Optional	Any string	It is the character format which is used to interconvert between

Name	Mandatory/optional	Valid value	Description
e_zone_format			n time with timezone and string inside the driver.
timestamp_with_timezone_format	Optional	Any string	It is the character format which is used to interconvert between timestamp with timezone and string inside the driver.
trace_log	Optional	boolean	It determines whether to log the trace. The default value is false.
tzeros	Optional	Any integer	When a numeric is expressed as a string and the number of zeros in digit goes beyond this value, it is expressed in exponent notation. The default value is 15.
user	Mandatory	Any string	It is user account name.
use_global_session	Optional	boolean	It is whether to use GLOBAL SESSION. The default value is false.
use_targettype	Optional	{"0", "1", "2"}	It is the information which is to be received together when receiving a column type through communication. <ul style="list-style-type: none"> <li>• 0: none</li> <li>• 1: name</li> <li>• 2: all</li> </ul>



- locator\_file is applied prior to locator\_host and locator\_port. For more information about locator\_file, refer to **Location File**.
- locator\_service property enables the access to the server belonging to locator\_service. For more information, refer to **glocator** and **gloctl**.

## Data Manipulation

### Data Manipulation Using Statement

Various SQL statements can be executed by using statement objects. Statement object can be obtained from the connection object as follows.

```
Connection con = DriverManager.getConnection(...);
Statement stmt = con.createStatement();
```

Various DML or DDL statements can be executed by using the execute method of the created statement object, and the executeUpdate method.

```
stmt.executeUpdate("create table emp ( id varchar(20), name varchar(30), age integer )");
stmt.executeUpdate("insert into emp values ('1234560000', 'Yuna', 24)");
int updated = stmt.executeUpdate("delete from emp where age > " + age);
```

The difference between `execute` and `executeUpdate` methods is only the return values. The `execute` method indicates whether the executed SQL statement returns `ResultSet`. The `executeUpdate` method returns the number of updated rows. The `execute` method can be used for both of DML and SELECT statements, but it throws `SQLException` if the `executeUpdate` method is used for SELECT statement.



Direct-execution refers to execution of SQL statement by using `statement`. It is the method of performing the prepare operation (parsing, validation, optimization) and execution for the SQL statement at a time. On the other hand, prepare-execution refers to the method of preparing the operation, then repeating the execution. Direct-execution repeatedly performs prepare and execution operation every time it is performed, so prepare-execution is more efficient when repeatedly performing the SQL statement.

## Data Manipulation Using PreparedStatement

The JDBC standard provides `PreparedStatement` interface which can use a parameter for data manipulation, and it enables a user to run it more efficiently. In addition, `PreparedStatement` quickly perform the repeated operation of the SQL statement because performs the prepare operation for the SQL statement only once.

```
Connection con = DriverManager.getConnection(...);
PreparedStatement pstmt = con.prepareStatement(
    "insert into emp values (?, ?, ?)");
pstmt.setString(1, "55544123000");
pstmt.setString(2, "Gildong");
pstmt.setInt(3, 32);
pstmt.executeUpdate();
pstmt.setString(1, "1357924680");
pstmt.setString(2, "Dooli");
pstmt.setInt(3, 41);
pstmt.executeUpdate();
```

After preparing the SQL statement as shown in the lines 2-3, the data is bound and performed. `PreparedStatement` which is prepared once, can bind and execute repeatedly.

If the binding is omitted and `execute()` is performed, the previously bound values are used.

```

pstmt.setString(1, "333555777000");
pstmt.setString(2, "Kang");
pstmt.setInt(3, 55);
pstmt.executeUpdate();
pstmt.setString(1, "245778884440");
pstmt.executeUpdate();

```

When the value is not bound to the second, third parameters as shown in line 6 but immediately executed, the value, "Kang" and 55, which was previously bound, is used. If the previously bound value does not exist, it throws `SQLException`.

All bound values are deleted by using `clearParameters()`.

```

pstmt.setString(1, "333555777000");
pstmt.setString(2, "Kang");
pstmt.setInt(3, 55);
pstmt.executeUpdate();
pstmt.clearParameters();
pstmt.setString(1, "245778884440");
pstmt.executeUpdate();

```

After deleting parameters in line 5, if the value is bound only to the first parameter and executed (line 7), then it throws `SQLException`.

The main reason to use `PreparedStatement` is because it can bind the data of various types. It is inconvenient to handle the data of the type such as binary or timestamp because the value can be expressed only in the character string when using `Statement`. Therefore, it is more convenient to bind all types by using `PreparedStatement`.

```

pstmt.setTimestamp(1,
    new Timestamp(Calendar.getInstance().getTimeInMillis()));
pstmt.setCharacterStream(2, new StringReader(BIG_STRING));
pstmt.setObject(3, someObj, Types.LONGVARCHAR);
pstmt.setObject(4, otherObj);

```

In the sample above, lines 1 ~ 2 binds `java.sql.Timestamp` object. The binding type (It is GOLDILOCKS type of the data when the data is sent to the server) is `TIMESTAMP`. For more information about the binding type which is determined by the various setter methods, refer to the corresponding API of **PreparedStatement**.

Line 3 binds a reader object, and it is bound as `LONG VARCHAR` type internally.

Line 4 binds the object of Java object type, and explicitly notifies that the type is `LONG VARCHAR`. For more information about GOLDILOCKS type which is mapped to the type of `Types`, refer to **Table 32-3 SQL ty**

pes → GOLDILOCKS types.

Line 5 literally binds the Java object type, and it is bound to the corresponding GOLDILOCKS data type according to the class type. For more information about mapping between class types and GOLDILOCKS data types, refer to [Table 32-2 Java objects → GOLDILOCKS types](#).

## Batch Execution Using Statement

The different SQL statements can be executed as the batch job by using `addBatch()` and `executeBatch()` of `Statement`.

```
stmt.addBatch("insert into emp values ('12345', 'Jake', 22)");
stmt.addBatch("insert into salary values ('12345', 5000)");
stmt.addBatch("update members set total_count=total_count+1 where age=22");
stmt.executeBatch();
```

Likewise, different SQL statements may be performed through a single `executeBatch()` method. However, this does not mean that the method call executes three statements in the server, gathers the results, sends the results to the JDBC driver with a single protocol. Internally, three times of protocol transmission, execution in the server and result transmission are performed. In other words, it does not have a big performance advantage.

After performing `executeBatch`, all registered jobs are deleted.

Even if an error occurs during execution, all registered jobs are performed until it is completed. Whether an error occurs or not can be known by the value of the returned `int []` type. In other words, if `int []` has `EXECUTE_FAILED` value, it means that the job is failed.

## Batch Execution Using PreparedStatement

More powerful batch operation can be performed by using `addBatch()` and `executeBatch()` methods of `PreparedStatement`.

```
PreparedStatement pstmt = con.prepareStatement("insert into emp values (?, ?, ?)");
pstmt.setString(1, "12345000");
pstmt.setString(2, "John");
pstmt.setInt(3, 33);
pstmt.addBatch();
pstmt.setString(1, "222333555");
pstmt.setString(2, "Henry");
pstmt.setInt(3, 24);
pstmt.addBatch();
int[] inserted = pstmt.executeBatch();
```

The example above is a process of inserting two rows. The values configuring the two rows are bound through `addBatch()`, and then if `executeBatch()` is called, the bound value and the protocol for execution are sent to the server and executed. It is more efficient than the batch execution of `Statement` and the performance is faster because communication occurs only when `executeBatch()` is called.

The new value should be bound to execute `executeBatch()` again because the bound values are deleted after executing `executeBatch()`. `clearBatch()` does not need to be explicitly called to delete the registered job after execution.

Even if an error occurs during execution, all registered jobs are performed until it is completed. Whether an error occurs or not can be known by the value of the returned `int []` type. In other words, if `int []` has `EXECUTE_FAILED` value, it means that the job is failed.

GOLDILOCKS JDBC provides a separate method which is `executeBatchAtomic()` in addition to `executeBatch()`. `executeBatch()` performs the execution as many as the number of the registered jobs in the server, but the response time is fast because `executeBatchAtomic()` performs the execution at once with the registered job (the bound values). However, if any one fails, everything fails as it can be seen from the name which is atomic. Therefore, the return type is not `int[]`, but `int`.

```
...
int inserted = ((GoldilocksPreparedStatement)pstmt).executeBatchAtomic();
```

## Data Retrieval

### Getting Column Values

The data can be retrieved through `ResultSet` object which is obtained by `executeQuery()` of the `Statement` or `PreparedStatement`.

```
...
ResultSet rs = pstmt.executeQuery();
while(rs.next())
{
    String id = rs.getString(1);
    String name = rs.getString(2);
    int age = rs.getInt(3);
    ...
}
```

The contents of the column can be obtained through various getter methods in the `ResultSet` after retrieving the data in the table. The data in the table is sent to JDBC drivers in the original form of GOLDILOCKS data type, and it is converted to an appropriate Java data type according to the types of getter methods c

alled by a user and it is transmitted to the user. For more information about type conversion mapping of GOLDILOCKS data type and getter method, refer to **Table 32-4 Whether supporting getter method for GOLDILOCKS type - 1**.

If GOLDILOCKS data type can not be converted to the type of getter, it throws SQLException.

## Closing ResultSet

The ResultSet which is used up can release the resources through close(). Even if a user does not explicitly call close(), the followings bring the result as same as when calling close() of ResultSet.

- When superordinate statement is closed
- When superordinate connection is closed
- When executeQuery() of Statement is called again
- When an error occurs during fetching

The two ResultSets which are created from a single statement can not be remained simultaneously in the third case above. Only the ResultSet object which is created by the last executeQuery() is valid.

## Fetch Size

JDBC can specify the number of rows fetched at once from the server through setFetchSize(int rows) of Statement. The default value of the ResultSet property of GOLDILOCKS is 0. 0 automatically determines the number of rows fetched by the server. For forward only, it is the maximum number of rows fetched in a communication packet. For scrollable, it is fixed to 100. If the value is too large, the amount of memory used by JDBC ResultSet becomes large. If the value is too small, the communication is frequently executed.

The value is mainly used in a scrollable ResultSet because it is not sensitive even when it is scroll sensitive while moving within the row cache of ResultSet. If the value is set too large, the latest information about the changes of rows can not be known.

## Field Size Limit

JDBC may limit the maximum length of the column through setMaxFieldSize(int size) of statement. The maximum length can be limited for the types of CHAR, VARCHAR, LONG VARCHAR, BINARY, VARBINARY, and LONG VARBINARY. The data bigger than the length is truncated. The default value is 0, and the maximum length is not limited in this case.

This property is ignored for other types such as INTEGER, DATE, etc..



## ResultSet Scroll

### Getting Scrollable ResultSet

There are two kinds of scrollable ResultSet, which are scroll sensitive and scroll insensitive. Scroll sensitive is the cursor type which can view the values changed by the transaction itself or other transaction while traversing the ResultSet, but scroll insensitive is not. GOLDILOCKS server supports both of the scroll types, and those facilities can be used by JDBC.

```
Statement stmt = con.createStatement(ResultSet.TYPE_SCROLL_SENSITIVE,
                                     ResultSet.CONCUR_READ_ONLY);
ResultSet rs = stmt.executeQuery("select id, name, age from emp");
```

If the ResultSet type is TYPE\_SCROLL\_INSENSITIVE when creating statement as line 1, ResultSet which is created from the statement object is scroll sensitive cursor. However, the current GOLDILOCKS does not support the updatable ResultSet.

The type should be set to TYPE\_SCROLL\_INSENSITIVE to obtain scroll insensitive ResultSet. The default value is TYPE\_FORWARD\_ONLY.

However, even it is a scroll sensitive ResultSet, a user can not know the latest value or whether it is changed, when moving within the row cache of ResultSet. The row should be fetched again from the server to find out the latest value or whether it is changed.

### Scrolling

JDBC API provides the following methods to scroll the cursor.

```
public boolean next() throws SQLException;
public boolean previous() throws SQLException;
public boolean first() throws SQLException;
public boolean last() throws SQLException;
public boolean absolute(int rows) throws SQLException;
public boolean relative(int rows) throws SQLException;
public void beforeFirst() throws SQLException;
public void afterLast() throws SQLException;
```

next() is the method which can be used for forward only or scrollable ResultSet, and it sets the cursor position to the next row. If the row can be read at the moved position, it is true. Otherwise, it is false. Other methods can be used only for scrollable ResultSet.

previous() moves the cursor to the previous row, first() moves the cursor to the first row, last() moves the

cursor to the last row, `absolute()` moves the cursor to the absolute position and `relative()` moves the cursor to the relative position from the current position. `beforeFirst()` moves the cursor to before the first row. `afterLast()` moves the cursor to after the last row.

```
rs.afterLast();
while (rs.previous())
{
    String id = rs.getString(1);
    String name = rs.getString(2);
    int age = rs.getInt(3);
    ...
}
```

The code above will query backwards from the last row to the first row.

The current cursor position can be known by the following method.

```
public int getRow() throws SQLException;
```

## Scrolling Principle

The `ResultSet` scroll is easy to use, but it may cause poor performance without knowing internal operating principles. Scrolling is performed in result cache within `ResultSet` of JDBC driver, but it is performed on the server in case when the range exceeds the cache, so the communication may occur. Therefore, it should be used carefully to prevent the poor performance.

The internal default value of the fetch size of scrollable `ResultSet` is 100 (the external default value is 0 and it can be changed through `setFetchSize()` method). It means that the number of rows that are fetched to JDBC driver at once are 100. The row cache of `ResultSet` consists of 100 rows, and the cursor position of `ResultSet` should be changed if the row position to be moved is in the cache. However, if it is not in the cache, the row at the position where to be moved should be got from the server. At this time, it is necessary to know how to get the row set including the row to be moved.

For example, if the `ResultSet` has rows from 1 to 100 and the current cursor position is at 100, calling `next()` will fetch rows 101 through 200 from the server because the next row does not exist in the cache. On the other hand, the rows from 101 to 200 are in `ResultSet` cache, and it is not appropriate to fetch rows from 100 to 199 from the server by calling `previous()` if the current cursor position is 101 row. When this approach is used, row should be fetched from the server whenever `previous()` is called. However, `GOLDLOCKS` fetches the rowset which includes the corresponding last row from the server when it is required to fetch the row from the server due to calling `previous()` to prevent this inefficiency. For example, when it is necessary to fetch row of the number 100 by calling `previous()`, `GOLDLOCKS` fetches the rows from 1 to 100. Then it is fetched in favor of `previous()`.

The rule is generalized as follows.

- If the position to be moved is after the current position, 100 rows (the fetch size) after that position are fetched.
- If the position to be moved is before the current position, 100 rows before that position are fetched.
- When moved with `first()`, the first 100 rows are fetched.
- When moved with `last()`, the last 100 rows are fetched.

When moved backward, the fetch is performed in favor of `next()`. When moved forward, the fetch is performed in favor of `previous()`. This is also applied to `absolute ()` and `relative ()`.

## Using Other Data Types

### Interval Type

GOLDILOCKS supports the following 13 types related to interval.

- interval year
- interval month
- interval year to month
- interval day
- interval hour
- interval minute
- interval second
- interval minute to second
- interval hour to minute
- interval hour to second
- interval day to hour
- interval day to minute
- interval day to second

`sunje.goldilocks.jdbc.GoldilocksInterval` object is created and the insert operation is executed by `setObject()` of `PreparedStatement` to insert the interval data into a table using JDBC.

`GoldilocksInterval` object can be created by using `createIntervalXXX` which is the static method of `GoldilocksInterval`.

```
import sunje.goldilocks.jdbc.GoldilocksInterval;
...
GoldilocksInterval interval = GoldilocksInterval.createIntervalDayToSecond(2, 6, "2
08:23:54.560843");
```

```
PreparedStatement pstmt = con.prepareStatement("insert into interval_table values (?,?)");
pstmt.setString(1, someId);
pstmt.setObject(2, interval);
pstmt.executeUpdate();
```

For more information about createIntervalXXX method, refer to **GoldilocksInterval**. Likewise, GoldilocksInterval is created and it is bound via setObject. Or, a type is explicitly specified as follows.

```
import sunje.goldilocks.jdbc.GoldilocksTypes;
...
pstmt.setObject(2, interval, GoldilocksTypes.INTERVAL_DAY_TO_SECOND);
```

The data may be inserted by using a character string without GoldilocksInterval object.

```
pstmt.setObject(2, "2 08:23:54.560843", GoldilocksTypes.INTERVAL_DAY_TO_SECOND);
```

In this case, a GoldilocksInterval object is created within JDBC driver and bound to a host variable. Or it may be bound as a string by using setString() method.

```
pstmt.setString(2, "2 08:23:54.560843");
```

The string is literally sent to the server when using this method, and the string is converted to Interval day to second type and inserted in the server.

getObject() or getString() of ResultSet queries the Interval type from the DB.

```
import sunje.goldilocks.jdbc.GoldilocksInterval;
ResultSet rs = stmt.executeQuery("select interval_value from some_table");
while (rs.next())
{
    GoldilocksInterval interval = (GoldilocksInterval)rs.getObject(1);
    System.out.println("type = " + interval.getTypeName() +
        ", value = " + interval.toString());
}
```

The data of GoldilocksInterval type can be retrieved via getObject() of ResultSet. GoldilocksInterval class provides getter like getYear(), getHour(), etc. that return various time data. For more information about getter API, refer to **GoldilocksInterval**.

## Time with Time Zone and Timestamp with Time Zone Types

Concerning time, GOLDILOCKS provides not only SQL standard types such as Date, Time, Timestamp but also Time with time zone and Timestamp with time zone types.

```
CREATE TABLE SAMPLE_TABLE ( C1 TIME WITH TIME ZONE,
                             C2 TIMESTAMP WITH TIME ZONE );
```

GOLDILOCKS JDBC provides setTimeTimeZone(int colIndex, Time time, Calendar timezone) method and setTimestampTimeZone(int colIndex, Timestamp time, Calendar timezone) method in GoldilocksPreparedStatement class to insert the data of Time with time zone and Timestamp with time zone types. For more information about specifications refer to **setTimeTimeZone** and **setTimestampTimeZone**.

The data can be inserted via existing setTime() and setTimestamp() methods, but the time zone value of the column is unconditionally set to the local time zone of Java execution environment. Therefore, setTimeTimeZone() or setTimestampTimeZone should be used to insert various time zone information.

Time, Timestamp data can be inserted with the given time zone value via setTimeTimeZone and setTimestampTimeZone.

```
import sunje.goldilocks.jdbc.GoldilocksPreparedStatement;
PreparedStatement pstmt = con.prepareStatement(
    "INSERT INTO SAMPLE_TABLE VALUES (?, ?, ?, ?)");
Calendar now = Calendar.getInstance();
Calendar usNow = Calendar.getInstance(TimeZone.getTimeZone("GMT-8"));
Time t = new Time(now.getTimeInMillis());
Timestamp ts = new Timestamp(now.getTimeInMillis());
pstmt.setTime(1, t);
pstmt.setTimestamp(2, ts);
pstmt.executeUpdate();
((GoldilocksPreparedStatement)pstmt).setTimeTimeZone(1, t, now);
((GoldilocksPreparedStatement)pstmt).setTimestampTimeZone(2, ts, now);
pstmt.executeUpdate();
((GoldilocksPreparedStatement)pstmt).setTimeTimeZone(1, t, usNow);
((GoldilocksPreparedStatement)pstmt).setTimestampTimeZone(2, ts, usNow);
pstmt.executeUpdate();
```

Line 11, 12 binds the column to time type and timestamp type. Each value of t and ts is sent to the server and the default time zone value is inserted to DB column in the server.

On the other hand, line 15, 16 binds the column to time with time zone type and timestamp with time zone type, and is sent to the server together with time zone information. As a result, if the time zone settings of a server and a client are same, the rows which are inserted by lines 11~13 and 15~17 are same.

Line 19, 20 inserts time zone information of GMT-8 time zone.

There are two ways to query data, which are time with time zone and timestamp with time zone. One is the way to get data as char from the server, and the other is the way to get data of the corresponding type by JDBC and to obtain as time or as timestamp object.

```
ResultSet rs = stmt.executeQuery("select c1, cast(c1 as char(33)), c2, cast(c2 as char(33))
from sample_table");
while (rs.next())
{
    System.out.println("c1 = " + rs.getTime(1).toString());
    System.out.println("c1 as char = " + rs.getString(2));
    System.out.println("c2 = " + rs.getTimestamp(3).toString());
    System.out.println("c2 as char = " + rs.getString(4));
}
```

When executing the code above, the results are as follows.

```
c1 = 12:35:26
c1 as char = 12:35:26.052000 +09:00
c2 = 2014-03-27 12:35:26.052
c2 as char = 2014-03-27 12:35:26.052000 +09:00
c1 = 12:35:26
c1 as char = 12:35:26.052000 +09:00
c2 = 2014-03-27 12:35:26.052
c2 as char = 2014-03-27 12:35:26.052000 +09:00
c1 = 12:35:26
c1 as char = 19:35:26.052000 -08:00
c2 = 2014-03-27 12:35:26.052
c2 as char = 2014-03-26 19:35:26.052000 -08:00
```

## Logging

### Logging Types

When developing a project by using JDBC, it is helpful in many ways for JDBC driver to leave various logs. GOLDILOCKS provides the facility to log the useful information even during operation, as well as the project development.

There are three types of log, which are trace log, protocol log and query log.

Trace log leaves information every time when JDBC API is called. It can be known which JDBC API is called. Protocol log shows the situation to send and receive communication packets between JDBC driver and GOLDILOCKS server. Query log records the SQL statement to be executed, when PreparedStatement or Statement is executed.

## Logging by Using DriverManager

First, the logging is left by using DriverManager. The logging media can be determined by using `setLogWriter()` method in DriverManager, and the type of logging to be left can be specified in connection url.

```
DriverManager.setLogWriter(new PrintWriter(System.out));
String url = "jdbc:goldilocks://localhost:22581/test?trace_log=on&query_log=on";
Connection con = DriverManager.getConnection(url, "TEST", "test");
```

Line 1 defines the logging media. All logging is output to the console. Line 2 defines the connection url, and the property can be defined after ? character. It means to using `trace_log`, `query_log`.

Likewise, these properties can be specified in URL, or they can be defined with properties object.

```
Properties prop = new Properties();
prop.put("trace_log", "on");
prop.put("query_log", "on");
prop.put("protocol_log", "on");
prop.put("user", "TEST");
prop.put("password", "test");
Connection con = DriverManager.getConnection(url, prop);
```

The connection properties which can be used in GOLDILOCKS are defined in **Table 32-1 Connection property**.

Sometimes it is difficult to call `setLogWriter()` of DriverManager. When using the middleware, the code like that can not be added. For such a case, GOLDILOCKS JDBC provides a global property called `global_logger`. Other general properties are limited to a single connection, but this property is global. In other words, if the property is set, it does not have to call `DriverManager.setLogWriter()`.

```
String url = "jdbc:goldilocks://localhost:22581/test?" +
            "global_logger=console&trace_log=on&query_log=on";
Connection con = DriverManager.getConnection(url, "TEST", "test");
```

`global_logger` property is applied only once initially, and it is ignored if log writer is already set in DriverManager. Only the current console is applicable as the property value. Other value does not cause any operation.

## Logging by Using DataSource

Unlike DriverManager, DataSource can set the log writer by each object. If the log writer is set for a DataSource object, all connections which are generated from the DataSource are logged by the log writer. The following describes how to set the logging in the DataSource.

```
import sunje.goldilocks.jdbc.GoldilocksDataSource;
...
GoldilocksDataSource ds = new sunje.goldilocks.jdbc.GoldilocksDataSource();
ds.setServerName("localhost");
ds.setDatabaseName("test");
ds.setUser("TEST");
ds.setPassword("test");
ds.setPortNumber(22581);
ds.setLogTarget("console");
ds.setTraceLog("on");
ds.setQueryLog("on");
ds.setProtocolLog("on");
Connection con = ds.getConnection();
```

Likewise, the logging feature is set by using setLogTarget(), setTraceLog(), setQueryLog() and setProtocolLog() methods. setLogWriter() of DataSource can be called instead of setLogTarget(). When using the middleware, the method such as setLogWriter() can not be directly called, so it should be controlled with the property. In this case, if logTarget, traceLog, queryLog and protocolLog properties are defined, the middleware automatically calls the methods.

## Viewing Plan Text

### Usage

The plan text can be obtained by using GOLDILOCKS JDBC like as the plan text of the executed statement is obtained by using GOLDILOCKS ODBC. It can be configured to generate a plan text by using non-standard API method in GoldilocksStatement class, or obtain the plan text which is already generated.

```
Connection con = ...
GoldilocksStatement stmt = (GoldilocksStatement)con.createStatement();
stmt.setExplainPlanOption(GoldilocksStatement.EXPLAIN_PLAN_OPTION_ON);
ResultSet rs = stmt.executeQuery("select * from t1");
System.out.println(stmt.getExplainPlan());
```



For example, when querying a simple table, the plan text is output as follows.

< Execution Plan >

```

=====
|  IDX  |  NODE DESCRIPTION  |  ROWS  |
=====
|   0   |  SELECT STATEMENT  |         |
|   1   |  TABLE ACCESS ("T1")  |         0 |
=====
1 - READ COLUMNS : A

```

## Option Types

GOLDILOCKS provides the following four properties about the plan text generation.

- `EXPLAIN_PLAN_OPTION_OFF`: It does not generate the plan text as the default value of the property related to the plan text of statement.
- `EXPLAIN_PLAN_OPTION_ON`: It generates the plan text when executing or fetching.
- `EXPLAIN_PLAN_OPTION_ON_VERBOSE`: It generates more detailed plan text such as execution time when executing or fetching.
- `EXPLAIN_PLAN_OPTION_ONLY`: It generates the plan text like as `EXPLAIN_PLAN_OPTION_ON` when executing or fetching but it is not actually executed.

These properties are set by using `GoldilocksStatement.setExplainPlanOption(int)` method, and the property which is set once is continuously maintained. A constant value of the property is defined in `GoldilocksStatement`.



The plan text for non-SELECT DML statements or other SQL statements is generated at run-time, but the plan text for the SELECT statements is generated when the SELECT statement is fetched and the cursor is positioned at the end in the server. The plan text should be obtained after all rows are traversed with `ResultSet` for the SELECT statement. The plan text can be obtained when there are few rows in a table because the cursor can traverse until the end in the server without fetching all rows.

## Connection Failover

GOLDILOCKS supports the connection failover of the client level (JDBC, ODBC). The application which accesses with client/ server mode by using the JDBC or ODBC to GOLDILOCKS, may perform connection to the alternative server automatically when the connection fails or disconnected. This allows a user to use hi

high availability applications which utilize multiple servers. In particular, when a user registers the main server URL and the alternative server URL through the connection property under interworking web server environment, it can safely use the connection object obtained from the connection pool without worrying about the interruption. Failover is performed entirely automatically inside the driver and the user does not need to worry about the reconnection logics.

`alternate_servers` property should be given to use failover. IP and port of the alternative server are given for this property, and it may indicate the multiple alternative servers by using the comma (,).

```

Class.forName("sunje.goldilocks.jdbc.GoldilocksDriver");
String url = "jdbc:goldilocks://192.168.0.101:22581/test";
Property prop = new Properties();
prop.setProperty("user", "TEST");
prop.setProperty("password", "test");
prop.setProperty("alternate_servers", "192.168.0.201:22581");
Connection con = DriverManager.getConnection(url, prop); ❶
Statement stmt = con.createStatement();
stmt.executeUpdate("insert into time_tab values (sysdate)"); ❷
...

```

For example, if ❶ fails to connect to the main server (192.168.0.101), it will automatically connect to an alternative server (192.168.0.201) and returns a connection object. Any error is not returned to the user. If it can not communicate with the server because the connection is broken at ❷ during `executeUpdate()` or before then, it automatically connects to the alternative server inside the driver and continues to use the existing connection object and returns `SQLException`. Users can continue to use the existing connection object after processing `SQLException`.

Whether failover or not can be viewed through `getWarnings()` of connection object.

A failover feature of GOLDILOCKS JDBC is that a user can continue to use statement object or `PreparedStatement` object created from connection object. (`ResultSet` can not continue to be used.)

In particular, a user can continue to use the object because `PreparedStatements` perform the prepare operations internally again in the alternative server if a failover occurs.

```

Connection con = DriverManager.getConnection(url, prop);
PreparedStatement pstmt =
    con.prepareStatement("insert into t1 values (?,?)");
...
try
{
    pstmt.setInt(1, 100);
    pstmt.setString(2, "John");
    pstmt.executeUpdate();
}

```

```

}
catch (SQLException sException)
{
    if (sException.getErrorCode() == 21012)
    {

```

- Failover occurs due to the communication link failure error.
- A user can continue to use the pstmt object.

```

pstmt.executeUpdate();
    }
    else
    {
        ...
    }
}

```

GOLDILOCKS JDBC driver provides some properties related to failover. These can help a user to decide the failover type, connection order and simple policy used for failover.

## failover\_type

The property is used to select the failover type. In the example above, the failover at ❶ is the connection failover and the failover at ❷ is the session failover. If the property value is *connection*, only the connection failover is used, and if it is *session*, both of the connection failover and session failover can be used. The default value is *session*.

## failover\_granularity

When failover occurs, the prepare operation is performed after the PreparedStatement objects which are generated from the current connection object are connected to the alternative server. If the prepare operation fails in the alternative server (An error may occur due to the different server environment.), the property is used to determine whether to consider the failover failed or to ignore the prepare error. The property value is either 0 or 1. If the property value is 0, the prepare error is ignored and the failover continuously proceeds. If the property value is 1, the failover is failed. The default value is 0. If the value is 0 and the prepare operation is failed, PreparedStatement object can not continue to be used and the user should directly create the PreparedStatement object again.

## Connecting in Direct Attach Mode

Since JDBC 1.1, Goldilocks provides the connection in direct attach mode (D/A mode) besides the existing connection in Client/ Server mode (C/S mode) based on TCP/ IP. Like as ODBC D/A connection mode, this is operated directly interworking with the server process. so the server module interworks within a single process (in a process same as jvm). Therefore, the remote host can not connect in D/A mode.

D/A mode is designed to utilize the merit of an in-memory DB GOLDILOCKS, which is a fast processing. TCP/ IP based connection offsets the fast processing of GOLDILOCKS by expensive cost, so an alternative method is required when a fast processing is required. Though it is restricted to be operated within the host which is same as the host of GOLDILOCKS server, this D/A mode connection is a good solution.

JDBC program connecting in D/A mode can directly call the server feature by loading GOLDILOCKS jni library when DB connection is created first within jvm. A server module can be directly called through native interface in jvm without network cost, it enables faster processing than the existing C/S mode.

## Connecting Method

Use `0.0.0.0:0` instead of existing `ip:port` in the connection URL to connect in D/A mode. The existing URL can be literally used and using a special `ip:port` address (`0.0.0.0:0`) can minimize changing existing applications. Or, use a special protocol (`da`) to connect in D/A mode.

```
Connection con =
    DriverManager.getConnection("jdbc:goldilocks://0.0.0.0:0/test", "TEST", "test");
```

or,

```
Connection con =
    DriverManager.getConnection("jdbc:goldilocks:da/test", "TEST", "test");
```

## Features of D/A Connection

GOLDILOCKS server module can be directly called in jvm when connecting in D/A mode. It is called through JNI (Java Native Interface) between JDBC program and GOLDILOCKS server module. It uses the server module with minimum call cost considering that it is expensive to call JNI, so it is faster double than the JDBC based on existing TCP/ IP.

When using the connection based on the existing TCP/ IP, it uses only `goldilocks6.jar` file. However, when using the connection based on D/A mode, it uses `libgoldilocksjni.so` file and `libgoldilocksas.so` file in `$GOLDILOCKS_HOME/lib` by dynamically loading them. Therefore, an error occurs when connecting if those two library files do not exist. However, the location of the library files need not to be separately specified when operating java program. Because it searches for those two library files and loads them as long as it i

s in the directory as same as the directory of goldilocks6.jar file.

## Global Connection

It support the global connection feature. When using the global connection, an application selects a node appropriate for a query process and performs it in the cluster environment.

### Settings

locator\_file or locator\_host, locator\_port should be set together with locality\_aware\_transaction property value to use the global connection. use\_global\_session property value should be set to 1 to use the global connection.

```
Properties prop = new Properties();
prop.put("locality_aware_transaction", "1");
prop.put("locator_file", "/home/goldilocks/.location.ini");
prop.put("user", "TEST");
prop.put("password", test");
Connection con = DriverManager.getConnection(url, prop);

String url = "jdbc:goldilocks://192.168.0.1:22581/test?" +
            "locality_aware_transaction=1&locator_host=192.168.0.2&locator_port=42581";
Connection con = DriverManager.getConnection(url, "TEST", "test");
```

### Procedure

1. Connect to the database.

After connecting to the server input by a user and receiving the information of the cluster system, the cluster system information is built through the locator file or glocator, then it connects to all nodes in the cluster system.

2. Execute the statement.

If the cluster system information is not built, then the cluster system information is built through the locator file or glocator, then it connects to all nodes in the cluster system.

When connecting to a new server by adding a node to the cluster, then it creates all statements of another node on the node, and is ready to execute SQL.

The statement class does not have the information about the sharding key, so the node is selected accord

ing to `locality_group_policy` or `locality_member_policy` property and the statement is executed.

If `PreparedStatement` or `CallableStatement` class does not have the information about the sharding key, then it builds the information about the sharding key of the SQL from an arbitrary server. If the information about the sharding key is built, then an appropriate node is selected by using the information about the sharding key or `locality_group_policy`, `locality_member_policy`, and the query is executed.

If an error occurs on the selected node, then it selects an appropriate node again except for that node, and executes the query.

If the sharding information is updated after executing the statement, then the built sharding key information is dropped.

If the cluster system information is updated by adding/ dropping the cluster node after executing the statement, then the built cluster system information is dropped.

### 3. Receive `ResultSet` data.

It receives the data from the node where SQL was executed.

### 4. Close `ResultSet`.

It closes a cursor on the node where SQL was executed.

### 5. Close the statement.

It releases the statement from all connected node.

### 6. Close the database.

It releases connection to all nodes.

## Exception Handling for High Availability

When using `GLOBAL CONNECTION`, if an error occurs on the selected node during the operation, then it is operated as follows according to the transaction occurrence and `SELECT` progress.

- When a transaction did not occur

If an error occurs on the selected node when a transaction did not occur, then it selects another node within JDBC and executes the query. Though an error occurred on the selected node, the query was normally executed on another node, so it does not transfer an error to a user.

- When a transaction occurred or `SELECT` is in progress

If an error occurs on the selected node when a transaction occurred or `ResultSet.next()` is in progress, the

n JDBC can not proceed the current operation any more so it transfers 21047(Retry the transactional operations again). If 21047 error occurs, then a user should perform the transaction or SELECT again.

```
PreparedStatement pstmt = con.prepareStatement("INSERT INTO T1 VALUES (?");
boolean retry;
do
{
    retry = false;
    try
    {
        pstmt.setInt(1, 1);
        pstmt.executeUpdate();
    }
    catch (SQLException e)
    {
        if (e.getErrorCode() == 21047)
        {
            retry = true;
        }
        else
        {
            throw e;
        }
    }
} while (retry == true);
```

```
PreparedStatement pstmt = con.prepareStatement("SELECT * FROM T1 WHERE C1 = ?");
boolean retry;
do
{
    retry = false;
    try
    {
        pstmt.setInt(1, 1);
        ResultSet rs = pstmt.executeQuery();
        while (rs.next())
        {
            ...
        }
        rs.close();
    }
}
```

```

    catch (SQLException e)
    {
        if (e.getErrorCode() == 21047)
        {
            retry = true;
        }
        else
        {
            throw e;
        }
    }
} while (retry == true);

```

- When committing or rolling back a transaction

If an error occurs on the selected node when committing a transaction, then JDBC checks whether the transaction has been committed before the error occurred through another node. Though an error occurred on the selected node, if the transaction was normally committed, then it does not transfer an error. Also, if an error occurred on the selected node when a transaction has not been committed, then it transfers 21047(Retry the transactional operations again) error. If 21047 error occurs, then a user should perform the transaction again.

If an error occurs on the selected node when rolling back a transaction, then JDBC does not transfer an error. It is because the transaction already has been rolled back due to the node error.

```

con.setAutoCommit(false);
PreparedStatement pstmt = con.prepareStatement("INSERT INTO T1 VALUES (?)");
boolean retry;
do
{
    retry = false;
    try
    {
        pstmt.setInt(1, 1);
        pstmt.executeUpdate();
        con.commit();
    }
    catch (SQLException e)
    {
        if (e.getErrorCode() == 21047)
        {
            retry = true;

```



```

        }
        else
        {
            throw e;
        }
    }
} while (retry == true);

```

## Constraints

- Use only PreparedStatement and CallableStatement class to select a node appropriate for SQL.

The statement class does not have the information required to select the node appropriate for the query, so the node is selected according to locality\_group\_policy or locality\_member\_policy property.

- Use Connection.commit(). Connection.rollback() to commit or rollback a transaction.

If committing or rolling back with SQL statement when using GLOBAL CONNECTION, then the status change of the transaction is not detected. It is mandatory to use Connection.commit(). Connection.rollback() to commit or rollback the transaction.

- Global session feature does not support Data Definition Language (DDL) among SQL statements.

## Statement Pooling

GOLDILOCKS supports the statement pooling feature. Statement pooling improves the performance by pooling statements which are repeatedly used such as a repetitive statement and a repeatedly called method. The interface for the statement pooling is defined in JDBC 3.0.

An application pools the statement related to a specific connection by using the statement pool. Each connection object has its own pool. GoldilocksConnection includes a method which enables the statement pool. If the statement pool is used, then the statement object is pooled when the close method is called.

## Description

If the statement pool is enabled and the close method of the statement object is called, then GOLDILOCKS JDBC driver automatically pools the statement, PreparedStatement and CallableStatement. PreparedStatement and CallableStatement objects perform pooling by using SQL string as a key value. JDBC driver automatically compares/ retrieves PreparedStatement or CallableStatement when creating them.

It is compared based on the following basis.

- SQL strings should be same.
- The statement types should be same.
- The result set properties should be same.

SQL string of the statement object is subject to change, so SQL string is not used for the pooling, but JDBC driver automatically processes it.

If the matching statement is retrieved while searching in the pool, then it is returned, and if it is not found, then a new statement is created. The statement, the cursor and the status are pooled in both cases if the close method of the object is called. However, the statement becomes closed. Create the statement whose SQL string, the statement type and the result set property are same to use the closed statement again.

If pooled PreparedStatement and CallableStatement objects are retrieved, then the status and the data information are automatically initialized again, and reset to the default value. When the statement pool is full, then it is dropped from the pool by LRU algorithm. Statements stored in the statement pool can be cleared when the close method of the connection object is called.

## Usage

### Enabling Statement Pool

STATEMENT\_POOL\_ON and STATEMENT\_POOL\_SIZE properties should be set to use the statement pool of the connection object. Even when STATEMENT\_POOL\_ON property is enabled, the default value of STATEMENT\_POOL\_SIZE is 0, so use the figure bigger than 0.

The statement pool feature is enabled by adding STATEMENT\_POOL\_ON and STATEMENT\_POOL\_SIZE properties to the properties object. The statement pool feature is also enabled through GoldilocksDataSource API and GoldilocksConnection API.

#### Enabling through GoldilocksDataSource

If GoldilocksDataSource class is used, then all connection objects gets statement pools with the identical STATEMENT\_POOL\_SIZE.

- Call setStatementPoolOn(true) method.
- Call setStatementPoolSize method.

```
GoldilocksDataSource sDataSource = new GoldilocksDataSource();
sDataSource.setStatementPoolOn( true );
sDataSource.setStatementPoolSize( 10 );
```

The property setting values can be viewed as follows.

```
System.out.println("Statement Pool on:" + sDataSource.getStatementPoolOn());
System.out.println("Statement Pool size:" + sDataSource.getStatementPoolSize());
```

### Enabling through GoldilocksConnection

If GoldilocksConnection class is used, then the statement pool is enabled aside from other objects.

- Call setStatementPoolOn(true) method.
- Call setStatementpoolSize method.

```
GoldilocksConnection sCon = sDataSource.getConnection();
sCon.setStatementPoolOn( true );
sCon.setStatementPoolSize( 10 );
```

The property setting values can be viewed as follows.

```
System.out.println("Statement Pool on:" + sCon.getStatementPoolOn());
System.out.println("Statement Pool size:" + sCon.getStatementPoolSize());
```

### Disabling Statement Pool

Enabled statement pool can be disabled. If switching the enabled status to the disabled status, then statements stored in the statement pool are dropped and closed.

Disabling by using setStatementPoolOn method

```
sCon.setStatementPoolOn(false);
```

Disabling by using setStatementPoolSize method

```
sCon.setStatementPoolSize(0);
```

### Creating Statement

The method to created the statement, PreparedStatement, and CallableStatement while the statement pool is enabled is as same as the general creating method.

The following is a code to create the new statement object.

```
PreparedStatement sPstmt = sCon.prepareStatement( "INSERT INTO EMP VALUES ( ?, ? )" );
```

### Disabling Specific Statement

If the statement pool is enabled, then GOLDILOCKS JDBC driver automatically pools all statements. Using setPoolable method excludes a specific statement from the pooling.

The following is an example of checking whether it is pooled by using `isPoolable` method and `setPoolable` method.

```
PreparedStatement sPstmt = sCon.prepareStatement( "SELECT 1 FROM DUAL" );  
System.out.println( "Is poolable: " + sPstmt.isPoolable() );  
sPstmt.setPoolable( false );  
System.out.println( "Is poolable: " + sPstmt.isPoolable() );
```

## 32.3 JDBC API References

### Array

The class is not implemented.

#### free

void free() throws SQLException

#### getArray

Object getArray() throws SQLException

Object getArray(Map<String,Class<?>> map) throws SQLException

Object getArray(long index, int count) throws SQLException

Object getArray(long index, int count, Map<String,Class<?>> map) throws SQLException

#### getBaseType

int getBaseType() throws SQLException

#### getBaseTypeName

String getBaseTypeName() throws SQLException

#### getResultSet

ResultSet getResultSet() throws SQLException

ResultSet getResultSet(Map<String,Class<?>> map) throws SQLException

| `ResultSet getResultSet(long index, int count)` throws `SQLException`

| `ResultSet getResultSet(long index, int count, Map<String,Class<?>> map)` throws `SQLException`

# Blob

## free

`void free()` throws `SQLException`

- Operation: It frees the sources owned by this object.
- Exception: It does not occur.

## getBinaryStream

`InputStream getBinaryStream()` throws `SQLException`

- Operation: It returns the blob object value in `InputStream` type.
- Exception: If the blob is freed, it throws `SQLException`.

`InputStream getBinaryStream(long pos, long length)` throws `SQLException`

- Operation: It returns `InputStream` type which includes the blob object value as big as the length from the byte defined as `pos`.
- Exception: When the blob is freed, if `pos` is smaller than 1 or bigger than the byte length of the blob object, or if `pos + length` is bigger than the byte length of blob object, then it throws `SQLException`.

## getBytes

`byte[] getBytes(long pos, int length)` throws `SQLException`

- Operation: It returns byte array which includes the blob object value as big as the length from the byte defined as `pos`.
- Exception: When the blob is freed, if `pos` is smaller than 1 or if the length is smaller than 0, then it throws `SQLException`.

## length

`long length()` throws `SQLException`

- Operation: It returns the byte length of the blob object.
- Exception: If the blob is freed, it throws `SQLException`.

## position

`long position(byte[] pattern, long start)` throws `SQLException`

- Operation: It returns the location of the byte from which the byte array pattern starts defined in the blob object value. pattern search starts from the location of start. If the pattern is not found in the blob object then -1 is returned.
- Exception: When the blob is freed, if start is smaller than 1, then it throws `SQLException`.

`long position(Blob pattern, long start)` throws `SQLException`

- Operation: It returns the location of the byte from which the blob object pattern starts defined in the blob object value. pattern search starts from the location of start. If the pattern is not found in the blob object then -1 is returned.
- Exception: When the blob is freed, if start is smaller than 1, then it throws `SQLException`.

## setBinaryStream

`OutputStream setBinaryStream(long pos)` throws `SQLException`

- Operation: It is not implemented.
- Exception: It always throws `SQLFeatureNotSupportedException`.

## setBytes

`int setBytes(long pos, byte[] bytes)` throws `SQLException`

- Operation: It records the byte array bytes from the given pos location in the blob object value, and returns the length of the recorded bytes. If the value exists in pos location, then the byte array is overwritten. If it reaches to the end of the blob value while recording byte array, then the length of the blob value is extended so that it can include the additional bytes.
- Exception: When the blob is freed, if pos is smaller than 1, then it throws `SQLException`.

`int setBytes(long pos, byte[] bytes, int offset, int len)` throws `SQLException`

- Operation: It records the blob object value from pos location as long as the len length from offset location of the given byte array bytes, and returns the length of the recorded bytes. If the value exists in pos location, then the byte array is overwritten. If it reaches to the end of the blob value while recording byte array, then the length of the blob value is extended so that it can include the additional bytes.
- Exception: When the blob is freed, if pos is smaller than 1 or offset is smaller than 0 or offset + len is bigger than bytes length, then it throws `SQLException`.



## truncate

`void truncate(long len) throws SQLException`

- Operation: It truncates the length of the blob object into the given len length.
- Exception: When the blob is freed, if len is smaller than 0, then it throws SQLException.

# CallableStatement

## getArray

Array `getArray(int parameterIndex)` throws `SQLException`

- Operation: It does not support an array type.
- Exception: It always returns `SQLFeatureNotSupportedException`.

Array `getArray(String parameterName)` throws `SQLException`

- Operation: It does not support an array type.
- Exception: It always returns `SQLFeatureNotSupportedException`.

## getBigDecimal

`BigDecimal getBigDecimal(int parameterIndex)` throws `SQLException`

- Operation: It obtains column data at `parameterIndex`-th position in `BigDecimal` type. For more information about whether it supports `GOLDILOCKS` types, refer to **Table 32-4 Whether supporting getter method for `GOLDILOCKS` type - 1**.
- Exception: If the `parameterIndex` is invalid, database is not accessible, or `CallableStatement` is already closed, then it throws `SQLException`.

`BigDecimal getBigDecimal(int parameterIndex, int scale)` throws `SQLException`

- Operation: It is not implemented. (It is a deprecated method.)
- Exception: It always throws `SQLFeatureNotSupportedException`.

`BigDecimal getBigDecimal(String parameterName)` throws `SQLException`

- Operation: It is not implemented.
- Exception: It always throws `SQLFeatureNotSupportedException`.

## getBlob

`Blob getBlob(int parameterIndex)` throws `SQLException`

- Operation: It obtains column data at `parameterIndex`-th position in blob type.
- Exception: If the `parameterIndex` is invalid, database is not accessible, or `CallableStatement` is already

closed, then it throws `SQLException`.

`Blob getBlob(String parameterName)` throws `SQLException`

- Operation: It is not implemented.
- Exception: It always throws `SQLFeatureNotSupportedException`.

## getBoolean

`boolean getBoolean(int parameterIndex)` throws `SQLException`

- Operation: It obtains column data at `parameterIndex`-th position in boolean type. For more information about whether it supports `GOLDILOCKS` types, refer to **Table 32-4 Whether supporting getter method for `GOLDILOCKS` type - 1**.
- Exception: If the `parameterIndex` is invalid, database is not accessible, or `CallableStatement` is already closed, then it throws `SQLException`.

`boolean getBoolean(String parameterName)` throws `SQLException`

- Operation: It is not implemented.
- Exception: It always throws `SQLFeatureNotSupportedException`.

## getBytes

`byte getByte(int parameterIndex)` throws `SQLException`

- Operation: It obtains column data at `parameterIndex`-th position in byte type. For more information about whether it supports `GOLDILOCKS` types, refer to **Table 32-4 Whether supporting getter method for `GOLDILOCKS` type - 1**.
- Exception: If the `parameterIndex` is invalid, database is not accessible, or `CallableStatement` is already closed, then it throws `SQLException`.

`byte getByte(String parameterName)` throws `SQLException`

- Operation: It is not implemented.
- Exception: It always throws `SQLFeatureNotSupportedException`.

## getBytes

`byte[] getBytes(int parameterIndex)` throws `SQLException`

- Operation: It obtains column data at parameterIndex-th position in byte[] type. For more information about whether it supports GOLDILOCKS types, refer to **Table 32-4 Whether supporting getter method for GOLDILOCKS type - 1**.
- Exception: If the parameterIndex is invalid, database is not accessible, or CallableStatement is already closed, then it throws SQLException.

byte[] getBytes(String parameterName) throws SQLException

- Operation: It is not implemented.
- Exception: It always throws SQLFeatureNotSupportedException.

## getCharacterStream

Reader getCharacterStream(int parameterIndex) throws SQLException

- Operation: It obtains column data at parameterIndex-th position in reader type. For more information about whether it supports GOLDILOCKS types, refer to **Table 32-4 Whether supporting getter method for GOLDILOCKS type - 1**.
- Exception: If the parameterIndex is invalid, database is not accessible, or CallableStatement is already closed, then it throws SQLException.

Reader getCharacterStream(String parameterName) throws SQLException

- Operation: It is not implemented.
- Exception: It always throws SQLFeatureNotSupportedException.

## getClob

Clob getClob(int parameterIndex) throws SQLException

- Operation: It obtains column data at parameterIndex-th position in clob type.
- Exception: If the parameterIndex is invalid, database is not accessible, or CallableStatement is already closed, then it throws SQLException.

Clob getClob(String parameterName) throws SQLException

- Operation: It is not implemented.
- Exception: It always throws SQLFeatureNotSupportedException.

## getDate

Date getDate(int parameterIndex) throws SQLException

- Operation: It obtains column data at parameterIndex-th position in date type. For more information about whether it supports GOLDILOCKS types, refer to **Table 32-4 Whether supporting getter method for GOLDILOCKS type - 1** . It uses local time zone and locale when creating a date object.
- Exception: If the parameterIndex is invalid, database is not accessible, or CallableStatement is already closed, then it throws SQLException.

Date getDate(int parameterIndex, Calendar cal) throws SQLException

- Operation: It obtains column data at parameterIndex-th position in date type. For more information about whether it supports GOLDILOCKS types, refer to **Table 32-4 Whether supporting getter method for GOLDILOCKS type - 1** . It uses time zone and locale of cal when creating a date object.
- Exception: If the parameterIndex is invalid, database is not accessible, or CallableStatement is already closed, then it throws SQLException.

Date getDate(String parameterName) throws SQLException

- Operation: It is not implemented.
- Exception: It always throws SQLFeatureNotSupportedException.

Date getDate(String parameterName, Calendar cal) throws SQLException

- Operation: It is not implemented.
- Exception: It always throws SQLFeatureNotSupportedException.

## getDouble

double getDouble(int parameterIndex) throws SQLException

- Operation: It obtains column data at parameterIndex-th position in double type. For more information about whether it supports GOLDILOCKS types, refer to **Table 32-4 Whether supporting getter method for GOLDILOCKS type - 1** .
- Exception: If the parameterIndex is invalid, database is not accessible, or CallableStatement is already closed, then it throws SQLException.

double getDouble(String parameterName) throws SQLException

- Operation: It is not implemented.
- Exception: It always throws SQLFeatureNotSupportedException.

## getFloat

`float getFloat(int parameterIndex)` throws `SQLException`

- Operation: It obtains column data at `parameterIndex`-th position in float type. For more information about whether it supports GOLDILOCKS types, refer to **Table 32-4 Whether supporting getter method for GOLDILOCKS type - 1**.
- Exception: If the `parameterIndex` is invalid, database is not accessible, or `CallableStatement` is already closed, then it throws `SQLException`.

`float getFloat(String parameterName)` throws `SQLException`

- Operation: It is not implemented.
- Exception: It always throws `SQLFeatureNotSupportedException`.

## getInt

`int getInt(int parameterIndex)` throws `SQLException`

- Operation: It obtains column data at `parameterIndex`-th position in int type. For more information about whether it supports GOLDILOCKS types, refer to **Table 32-4 Whether supporting getter method for GOLDILOCKS type - 1**.
- Exception: If the `parameterIndex` is invalid, database is not accessible, or `CallableStatement` is already closed, then it throws `SQLException`.

`int getInt(String parameterName)` throws `SQLException`

- Operation: It is not implemented.
- Exception: It always throws `SQLFeatureNotSupportedException`.

## getLong

`long getLong(int parameterIndex)` throws `SQLException`

- Operation: It obtains column data at `parameterIndex`-th position in long type. For more information about whether it supports GOLDILOCKS types, refer to **Table 32-4 Whether supporting getter method for GOLDILOCKS type - 1**.
- Exception: If the `parameterIndex` is invalid, database is not accessible, or `CallableStatement` is already closed, then it throws `SQLException`.

`long getLong(String parameterName)` throws `SQLException`

- Operation: It is not implemented.
- Exception: It always throws `SQLFeatureNotSupportedException`.

## getNCharacterStream

`Reader getNCharacterStream(int parameterIndex)` throws `SQLException`

- Operation: Currently, it does not support NCHAR-family type.
- Exception: It always throws `SQLFeatureNotSupportedException`.

`Reader getNCharacterStream(String parameterName)` throws `SQLException`

- Operation: Currently, it does not support NCHAR-family type.
- Exception: It always throws `SQLFeatureNotSupportedException`.

## getNClob

`NClob getNClob(int parameterIndex)` throws `SQLException`

- Operation: Currently, it does not support NClob-family type.
- Exception: It always throws `SQLFeatureNotSupportedException`.

`NClob getNClob(String parameterName)` throws `SQLException`

- Operation: Currently, it does not support NClob-family type.
- Exception: It always throws `SQLFeatureNotSupportedException`.

## getString

`String getString(int parameterIndex)` throws `SQLException`

- Operation: Currently, it does not support NCHAR-family type.
- Exception: It always throws `SQLFeatureNotSupportedException`.

`String getString(String parameterName)` throws `SQLException`

- Operation: Currently, it does not support NCHAR-family type.
- Exception: It always throws `SQLFeatureNotSupportedException`.

## getObject

Object getObject(int parameterIndex) throws SQLException

- Operation: It obtains column data at parameterIndex-th position in Java object type. For more information about whether it supports GOLDILOCKS types, refer to **Table 32-4 Whether supporting getter method for GOLDILOCKS type - 1**.
- Exception: If the parameterIndex is invalid, database is not accessible, or CallableStatement is already closed, then it throws SQLException.

Object getObject(int parameterIndex, Map<String,Class<?>> map) throws SQLException

- Operation: It is not supported.
- Exception: It always throws SQLFeatureNotSupportedException.

Object getObject(String parameterName) throws SQLException

- Operation: It is not implemented.
- Exception: It always throws SQLFeatureNotSupportedException.

Object getObject(String parameterName, Map<String,Class<?>> map) throws SQLException

- Operation: It is not supported.
- Exception: It always throws SQLFeatureNotSupportedException.

## getRef

Ref getRef(int parameterIndex) throws SQLException

- Operation: It does not support ref type.
- Exception: It always returns SQLFeatureNotSupportedException.

Ref getRef(String parameterName) throws SQLException

- Operation: It does not support ref type.
- Exception: It always returns SQLFeatureNotSupportedException.

## getRowId

RowId getRowId(int parameterIndex) throws SQLException

- Operation: It obtains column data at parameterIndex-th position in rowid type. For more information



about whether it supports GOLDILOCKS types, refer to **Table 32-4 Whether supporting getter method for GOLDILOCKS type - 1**.

- Exception: If the parameterIndex is invalid, database is not accessible, or CallableStatement is already closed, then it throws SQLException.

**RowId** `getRowId(String parameterName)` throws SQLException

- Operation: It is not implemented.
- Exception: It always throws SQLFeatureNotSupportedException.

## getShort

**short** `getShort(int parameterIndex)` throws SQLException

- Operation: It obtains column data at parameterIndex-th position in short type. For more information about whether it supports GOLDILOCKS types, refer to **Table 32-4 Whether supporting getter method for GOLDILOCKS type - 1**.
- Exception: If the parameterIndex is invalid, database is not accessible, or CallableStatement is already closed, then it throws SQLException.

**short** `getShort(String parameterName)` throws SQLException

- Operation: It is not implemented.
- Exception: It always throws SQLFeatureNotSupportedException.

## getSQLXML

**SQLXML** `getSQLXML(int parameterIndex)` throws SQLException

- Operation: It does not support SQLXML type.
- Exception: It always returns SQLFeatureNotSupportedException.

**SQLXML** `getSQLXML(String parameterName)` throws SQLException

- Operation: It does not support SQLXML type.
- Exception: It always returns SQLFeatureNotSupportedException.

## getString

**String** `getString(int parameterIndex)` throws SQLException

- Operation: It obtains column data at parameterIndex-th position in string type. For more information about whether it supports GOLDILOCKS types, refer to **Table 32-4 Whether supporting getter method for GOLDILOCKS type - 1**.
- Exception: If the parameterIndex is invalid, database is not accessible, or CallableStatement is already closed, then it throws SQLException.

String getString(String parameterName) throws SQLException

- Operation: It is not implemented.
- Exception: It always throws SQLFeatureNotSupportedException.

## getTime

Time getTime(int parameterIndex) throws SQLException

- Operation: It obtains column data at parameterIndex-th position in time type. For more information about whether it supports GOLDILOCKS types, refer to **Table 32-4 Whether supporting getter method for GOLDILOCKS type - 1**. It uses local time zone when creating a time object.
- Exception: If the parameterIndex is invalid, database is not accessible, or CallableStatement is already closed, then it throws SQLException.

Time getTime(int parameterIndex, Calendar cal) throws SQLException

- Operation: It obtains column data at parameterIndex-th position in time type. For more information about whether it supports GOLDILOCKS types, refer to **Table 32-4 Whether supporting getter method for GOLDILOCKS type - 1**. It uses time zone of cal when creating a time object.
- Exception: If the parameterIndex is invalid, database is not accessible, or CallableStatement is already closed, then it throws SQLException.

Time getTime(String parameterName) throws SQLException

- Operation: It is not implemented.
- Exception: It always throws SQLFeatureNotSupportedException.

Time getTime(String parameterName, Calendar cal) throws SQLException

- Operation: It is not implemented.
- Exception: It always throws SQLFeatureNotSupportedException.

## getTimestamp

Timestamp `getTimestamp(int parameterIndex)` throws `SQLException`

- Operation: It obtains column data at `parameterIndex`-th position in timestamp type. For more information about whether it supports GOLDILOCKS types, refer to **Table 32-4 Whether supporting getter method for GOLDILOCKS type - 1**. It uses local time zone when creating a timestamp object.
- Exception: If the `parameterIndex` is invalid, database is not accessible, or `CallableStatement` is already closed, then it throws `SQLException`.

Timestamp `getTimestamp(int parameterIndex, Calendar cal)` throws `SQLException`

- Operation: It obtains column data at `parameterIndex`-th position in timestamp type. For more information about whether it supports GOLDILOCKS types, refer to **Table 32-4 Whether supporting getter method for GOLDILOCKS type - 1**. It uses time zone of `cal` when creating a timestamp object.
- Exception: If the `parameterIndex` is invalid, database is not accessible, or `CallableStatement` is already closed, then it throws `SQLException`.

Timestamp `getTimestamp(String parameterName)` throws `SQLException`

- Operation: It is not implemented.
- Exception: It always throws `SQLFeatureNotSupportedException`.

Timestamp `getTimestamp(String parameterName, Calendar cal)` throws `SQLException`

- Operation: It is not implemented.
- Exception: It always throws `SQLFeatureNotSupportedException`.

## getURL

URL `getURL(int parameterIndex)` throws `SQLException`

- Operation: It does not support URL type.
- Exception: It always returns `SQLFeatureNotSupportedException`.

URL `getURL(String parameterName)` throws `SQLException`

- Operation: It does not support URL type.
- Exception: It always returns `SQLFeatureNotSupportedException`.

## registerOutParameter

`void registerOutParameter(int parameterIndex, int sqlType) throws SQLException`

- Operation: It registers out parameters positioned in parameterIndex as sqlType. All out parameters should be registered before executing the stored procedure. JDBC type of out parameter specified as sqlType determines Java type which is used in a get method to read parameter parameter value. For more information about whether it supports GOLDILOCKS types, refer to **Table 32-4 Whether supporting getter method for GOLDILOCKS type - 1**.
- Exception: If the parameterIndex is invalid, database is not accessible, or CallableStatement is already closed, then it throws SQLFeatureNotSupportedException.

`void registerOutParameter(int parameterIndex, int sqlType, int scale) throws SQLException`

- Operation: It is not implemented.
- Exception: It always throws SQLFeatureNotSupportedException.

`void registerOutParameter(int parameterIndex, int sqlType, String typeName) throws SQLException`

- Operation: It is not implemented.
- Exception: It always throws SQLFeatureNotSupportedException.

`void registerOutParameter(String parameterName, int sqlType) throws SQLException`

- Operation: It is not implemented.
- Exception: It always throws SQLFeatureNotSupportedException.

`void registerOutParameter(String parameterName, int sqlType, int scale) throws SQLException`

- Operation: It is not implemented.
- Exception: It always throws SQLFeatureNotSupportedException.

`void registerOutParameter(String parameterName, int sqlType, String typeName) throws SQLException`

- Operation: It is not implemented.
- Exception: It always throws SQLFeatureNotSupportedException.

## setAsciiStream

`void setAsciiStream(String parameterName, InputStream x) throws SQLException`

- Operation: It is not implemented.
- Exception: It always throws `SQLFeatureNotSupportedException`.

`void setAsciiStream(String parameterName, InputStream x, int length) throws SQLException`

- Operation: It is not implemented.
- Exception: It always throws `SQLFeatureNotSupportedException`.

`void setAsciiStream(String parameterName, InputStream x, long length) throws SQLException`

- Operation: It is not implemented.
- Exception: It always throws `SQLFeatureNotSupportedException`.

## setBigDecimal

`void setBigDecimal(String parameterName, BigDecimal x) throws SQLException`

- Operation: It is not implemented.
- Exception: It always throws `SQLFeatureNotSupportedException`.

## setBinaryStream

`void setBinaryStream(String parameterName, InputStream x) throws SQLException`

- Operation: It is not implemented.
- Exception: It always throws `SQLFeatureNotSupportedException`.

`void setBinaryStream(String parameterName, InputStream x, int length) throws SQLException`

- Operation: It is not implemented.
- Exception: It always throws `SQLFeatureNotSupportedException`.

`void setBinaryStream(String parameterName, InputStream x, long length) throws SQLException`

- Operation: It is not implemented.
- Exception: It always throws `SQLFeatureNotSupportedException`.

## setBlob

`void setBlob(String parameterName, Blob x) throws SQLException`

- Operation: It does not support blob type.
- Exception: It always returns `SQLFeatureNotSupportedException`.

`void setBlob(String parameterName, InputStream inputStream) throws SQLException`

- Operation: It does not support blob type.
- Exception: It always returns `SQLFeatureNotSupportedException`.

`void setBlob(String parameterName, InputStream inputStream, long length) throws SQLException`

- Operation: It does not support blob type.
- Exception: It always returns `SQLFeatureNotSupportedException`.

## setBoolean

`void setBoolean(String parameterName, boolean x) throws SQLException`

- Operation: It is not implemented.
- Exception: It always throws `SQLFeatureNotSupportedException`.

## setByte

`void setByte(String parameterName, byte x) throws SQLException`

- Operation: It is not implemented.
- Exception: It always throws `SQLFeatureNotSupportedException`.

## setBytes

`void setBytes(String parameterName, byte[] x) throws SQLException`

- Operation: It is not implemented.
- Exception: It always throws `SQLFeatureNotSupportedException`.

## setCharacterStream

`void setCharacterStream(String parameterName, Reader reader) throws SQLException`

- Operation: It is not implemented.
- Exception: It always throws `SQLFeatureNotSupportedException`.

`void setCharacterStream(String parameterName, Reader reader, int length) throws SQLException`

- Operation: It is not implemented.
- Exception: It always throws `SQLFeatureNotSupportedException`.

`void setCharacterStream(String parameterName, Reader reader, long length) throws SQLException`

- Operation: It is not implemented.
- Exception: It always throws `SQLFeatureNotSupportedException`.

## setClob

`void setClob(String parameterName, Clob x) throws SQLException`

- Operation: It does not support clob type.
- Exception: It always returns `SQLFeatureNotSupportedException`.

`void setClob(String parameterName, Reader reader) throws SQLException`

- Operation: It does not support clob type.
- Exception: It always returns `SQLFeatureNotSupportedException`.

`void setClob(String parameterName, Reader reader, long length) throws SQLException`

- Operation: It does not support clob type.
- Exception: It always returns `SQLFeatureNotSupportedException`.

## setDate

`void setDate(String parameterName, Date x) throws SQLException`

- Operation: It is not implemented.
- Exception: It always throws `SQLFeatureNotSupportedException`.

`void setDate(String parameterName, Date x, Calendar cal) throws SQLException`

- Operation: It is not implemented.
- Exception: It always throws `SQLFeatureNotSupportedException`.

## setDouble

`void setDouble(String parameterName, double x) throws SQLException`

- Operation: It is not implemented.
- Exception: It always throws `SQLFeatureNotSupportedException`.

## setFloat

`void setFloat(String parameterName, float x) throws SQLException`

- Operation: It is not implemented.
- Exception: It always throws `SQLFeatureNotSupportedException`.

## setInt

`void setInt(String parameterName, int x) throws SQLException`

- Operation: It is not implemented.
- Exception: It always throws `SQLFeatureNotSupportedException`.

## setLong

`void setLong(String parameterName, long x) throws SQLException`

- Operation: It is not implemented.
- Exception: It always throws `SQLFeatureNotSupportedException`.

## setNCharacterStream

`void setNCharacterStream(String parameterName, Reader value) throws SQLException`

- Operation: It does not support `NChar`.
- Exception: It always throws `SQLFeatureNotSupportedException`.



`void setNCharacterStream(String parameterName, Reader value, long length) throws SQLException`

- Operation: It does not support NChar.
- Exception: It always throws `SQLFeatureNotSupportedException`.

## setNClob

`void setNClob(String parameterName, NClob value) throws SQLException`

- Operation: It does not support NClob.
- Exception: It always throws `SQLFeatureNotSupportedException`.

`void setNClob(String parameterName, Reader reader) throws SQLException`

- Operation: It does not support NClob.
- Exception: It always throws `SQLFeatureNotSupportedException`.

`void setNClob(String parameterName, Reader reader, long length) throws SQLException`

- Operation: It does not support NClob.
- Exception: It always throws `SQLFeatureNotSupportedException`.

## setNString

`void setNString(String parameterName, String value) throws SQLException`

- Operation: It does not support NChar.
- Exception: It always throws `SQLFeatureNotSupportedException`.

## setNull

`void setNull(String parameterName, int sqlType) throws SQLException`

- Operation: It is not implemented.
- Exception: It always throws `SQLFeatureNotSupportedException`.

`void setNull(String parameterName, int sqlType, String typeName) throws SQLException`

- Operation: It is not implemented.
- Exception: It always throws `SQLFeatureNotSupportedException`.

## setObject

`void setObject(String parameterName, Object x) throws SQLException`

- Operation: It is not implemented.
- Exception: It always throws `SQLFeatureNotSupportedException`.

`void setObject(String parameterName, Object x, int targetSqlType) throws SQLException`

- Operation: It is not implemented.
- Exception: It always throws `SQLFeatureNotSupportedException`.

`void setObject(String parameterName, Object x, int targetSqlType, int scale) throws SQLException`

- Operation: It is not implemented.
- Exception: It always throws `SQLFeatureNotSupportedException`.

## setRowId

`void setRowId(String parameterName, RowId x) throws SQLException`

- Operation: It is not implemented.
- Exception: It always throws `SQLFeatureNotSupportedException`.

## setShort

`void setShort(String parameterName, short x) throws SQLException`

- Operation: It is not implemented.
- Exception: It always throws `SQLFeatureNotSupportedException`.

## setSQLXML

`void setSQLXML(String parameterName, SQLXML xmlObject) throws SQLException`

- Operation: It does not support `SQLXML` type.
- Exception: It always returns `SQLFeatureNotSupportedException`.

## setString

`void setString(String parameterName, String x) throws SQLException`

- Operation: It is not implemented.
- Exception: It always throws `SQLFeatureNotSupportedException`.

## setTime

`void setTime(String parameterName, Time x) throws SQLException`

- Operation: It is not implemented.
- Exception: It always throws `SQLFeatureNotSupportedException`.

`void setTime(String parameterName, Time x, Calendar cal) throws SQLException`

- Operation: It is not implemented.
- Exception: It always throws `SQLFeatureNotSupportedException`.

## setTimestamp

`void setTimestamp(String parameterName, Timestamp x) throws SQLException`

- Operation: It is not implemented.
- Exception: It always throws `SQLFeatureNotSupportedException`.

`void setTimestamp(String parameterName, Timestamp x, Calendar cal) throws SQLException`

- Operation: It is not implemented.
- Exception: It always throws `SQLFeatureNotSupportedException`.

## setURL

`void setURL(String parameterName, URL val) throws SQLException`

- Operation: It does not support URL type.
- Exception: It always throws `SQLFeatureNotSupportedException`.

## wasNull

`boolean wasNull()`

- Operation: It is not implemented.
- Exception: It always throws `SQLFeatureNotSupportedException`.

## isWrapperFor

`boolean isWrapperFor(Class<?> iface)`

- Operation: It is not implemented.
- Exception: It always throws `SQLFeatureNotSupportedException`.

## unwrap

`boolean isWrapperFor(Class<?> iface)`

- Operation: It is not implemented.
- Exception: It always throws `SQLFeatureNotSupportedException`.

# Clob

## free

`void free()` throws `SQLException`

- Operation: It frees the sources owned by this object.
- Exception: It does not occur.

## getAsciiStream

`InputStream getAsciiStream()` throws `SQLException`

- Operation: It returns the clob object value in `InputStream` type.
- Exception: If the clob is freed, it throws `SQLException`.

## getCharacterStream

`Reader getCharacterStream()` throws `SQLException`

- Operation: It returns the clob object value in reader type.
- Exception: If the clob is freed, it throws `SQLException`.

`Reader getCharacterStream(long pos, long length)` throws `SQLException`

- Operation: It returns the clob object value in reader type as big as the length from the location defined as `pos`.
- Exception: When the blob is freed, if `pos` is smaller than 1 or if `length` is smaller than 1, or if `pos + length` is equal to or bigger than the length of clob object, then it throws `SQLException`.

## getSubString

`String getSubString(long pos, int length)` throws `SQLException`

- Operation: It returns the string which includes the clob object value as big as the length from the length defined as `pos`.
- Exception: When the clob is freed, if `pos` is smaller than 1 or if `length` is smaller than 0, then it throws `SQLException`.

## length

`long length()` throws `SQLException`

- Operation: It returns the data length of the clob object.
- Exception: If the clob object is freed, it throws `SQLException`.

## position

`long position(Clob searchstr, long start)` throws `SQLException`

- Operation: It returns the location from which the clob object `searchstr` starts defined in the clob object value. `searchstr` search starts from the location of `start`. If `searchstr` is not found in the clob object then `-1` is returned.
- Exception: When the clob is freed, if `start` is smaller than `1`, then it throws `SQLException`.

`long position(String searchstr, long start)` throws `SQLException`

- Operation: It returns the location from which the string object `searchstr` starts defined in the clob object value. `searchstr` search starts from the location of `start`. If `searchstr` is not found in the clob object then `-1` is returned.
- Exception: When the clob is freed, if `start` is smaller than `1`, then it throws `SQLException`.

## setAsciiStream

`OutputStream setAsciiStream(long pos)` throws `SQLException`

- Operation: It is not implemented.
- Exception: It always throws `SQLFeatureNotSupportedException`.

## setCharacterStream

`Writer setCharacterStream(long pos)` throws `SQLException`

- Operation: It is not implemented.
- Exception: It always throws `SQLFeatureNotSupportedException`.

## setString

`int setString(long pos, String str) throws SQLException`

- Operation: It records `str` from the given `pos` location in the clob object value, and returns the recorded length. If the value exists in `pos` location, then it is overwritten. If it reaches to the end of the clob value while recording the string type, then the length of the clob value is extended so that it can include the additional bytes.
- Exception: When the clob is freed, if `pos` is smaller than 1, then it throws `SQLException`.

`int setString(long pos, String str, int offset, int len) throws SQLException`

- Operation: It records the clob object value from `pos` location as long as the `len` length from `offset` location of the given string object `str`, and returns the recorded length. If the value exists in `pos` location, then the value is overwritten. If it reaches to the end of the clob value while recording the string type, then the length of the clob value is extended so that it can include the additional bytes.
- Exception: When the clob is freed, if `pos` is smaller than 1 or if it is bigger than `offset + len`, then it throws `SQLException`.

## truncate

`void truncate(long len) throws SQLException`

- Operation: It truncates the length of the clob object into the given `len` length.
- Exception: When the clob is freed, if `len` is smaller than 0 or if the clob size is smaller than `len`, then it throws `SQLException`.

## CommonDataSource

### getLoginTimeout

`int getLoginTimeout()` throws `SQLException`

- Operation: It returns the login timeout setting value. Login timeout is used as a timeout value when performing socket connection to the server. If the value is not set, 0 is returned. 0 means infinite standby.
- Exception: It does not occur.

### getLogWriter

`PrintWriter getLogWriter()` throws `SQLException`

- Operation: It returns the log writer which is set in the DataSource. If it is not set, null is returned. Log writer refers to `PrintWriter` to write various trace logs. For more information about logging, refer to **Logging**.
- Exception: It does not occur.

### setLoginTimeout

`void setLoginTimeout(int seconds)` throws `SQLException`

- Operation: It sets the login timeout value. Login timeout is used as a timeout value when performing socket connection to the server. 0 means infinite standby.
- Exception: It does not occur.

### setLogWriter

`void setLogWriter(PrintWriter out)` throws `SQLException`

- Operation: It sets the log writer in DataSource. If the value is not set, the default value is null. Log writer refers to `PrintWriter` to write various trace logs. If the value is set, trace log, query log, and protocol log are written according to the options, and connection object which is created from DataSource and all objects which are created from connection object such as Statement, ResultSet, perform logging. Trace log, query log, protocol log options can be specified in the connection url or property. For more information about logging, refer to **Logging**.
- Exception: It does not occur.



## setDataSourceName

```
void setDataSourceName(String aDataSourceName)
```

- Operation: It sets the data source name. It is not the mandatory information required for the connection. It is the information charged separately to distinguish objects.
- Exception: It does not occur.

## setServerName

```
void setServerName(String aServerName)
```

- Operation: It sets the server name, which is the connection URL. It is the mandatory information required for the connection.
- Exception: It does not occur.

## setDatabaseName

```
void setDatabaseName(String aDBName)
```

- Operation: It sets the database name. It is the mandatory information required for the connection.
- Exception: It does not occur.

## setNetworkProtocol

```
void setNetworkProtocol(String aProtocol)
```

- Operation: It is the network protocol information. It is not the mandatory information required for the connection.
- Exception: It does not occur.

## setUser

```
void setUser(String aUser)
```

- Operation: It sets the connection account name. It is the mandatory information required for the connection.
- Exception: It does not occur.

## setPassword

`void setPassword(String aPassword)`

- Operation: It sets the connection account password. It is the mandatory information required for the connection.
- Exception: It does not occur.

## setPortNumber

`void setPortNumber(int aPort)`

- Operation: It sets the port number used when connecting to the server. It is the mandatory information required for the connection.
- Exception: It does not occur.

`void setPortNumber(String aPort)`

- Operation: It sets the port number used when connecting to the server. It is the mandatory information required for the connection.
- Exception: It does not occur.

## setRoleName

`void setRoleName(String aRoleName)`

- Operation: It specifies the role of when connecting to server. It is not mandatory information required for the connection, but it is the connection related information. One of "", "ADMIN", "SYSDBA" is specified.
- Exception: It does not occur.

## setDescription

`void setDescription(String aDescription)`

- Operation: It sets the description about the data source. It is not used for the connection.
- Exception: It does not occur.

## setConnectionProperties

void setConnectionProperties(Properties aProps)

- Operation: It defines the properties which can be used in various connections.
- Exception: It does not occur.

## setURL

void setURL(String aURL) throws SQLException

- Operation: It specifies the serverName, portNumber, and database Name in URL form. It has URL as same as the URL of when connecting via DriverManager.
- Exception: If it is the wrong format, it throws SQLException.

void setUrl(String aUrl) throws SQLException

It is as same as setURL (String aURL).

## setLogTarget

void setLogTarget(String aTarget)

- Operation: If setLogWriter can not be called, the log writer is set by this method. Currently, it is supported only when aTarget is "console", other values are ignored. If it is set to "console", all loggings below the connection object which is generated from the DataSource are output to the console.
- Exception: It does not occur.

## setTraceLog

void setTraceLog(String aMode)

- Operation: It sets the trace log. If aMode is *on*, the trace logging is on.
- Exception: It does not occur.

## setQueryLog

void setQueryLog(String aMode)

- Operation: It sets the query log. If aMode is *on*, the query logging is on.

- Exception: It does not occur.

## setProtocolLog

`void setProtocolLog(String aMode)`

- Operation: It sets the protocol log. If *aMode* is *on*, the protocol logging is on.
- Exception: It does not occur.

# Connection

## clearWarnings

`void clearWarnings()` throws **SQLException**

- Operation: It clears the warning object(s) owned by the current connection object.
- Exception: It does not occur.

## close

`void close()` throws **SQLException**

- Operation: It breaks the connection with GOLDILOCKS not to use anymore the current connection and closes all statement objects created from the object. If already closed, any operation is not performed.
- Exception: It may happen when an error occurs from the server or it does not respond.

## commit

`void commit()` throws **SQLException**

- Operation: For non-auto commit mode, the commit is executed for the current connection.
- Exception: If it is already closed or is on the auto-commit mode, it throws **SQLException**.

## createArrayOf

`Array createArrayOf(String typeName, Object[] elements)` throws **SQLException**

- Operation: It is not implemented.
- Exception: It always throws **SQLFeatureNotSupportedException**.

## createBlob

`Blob createBlob()` throws **SQLException**

- Operation: It creates the object which implemented the blob interface. The first returned object does not have a data. The data can be added to the blob object by using `setBytes` method of the blob interface.

- Exception: If it is already closed, it throws `SQLException`.

## createClob

Clob `createClob()` throws `SQLException`

- Operation: It creates the object which implemented the clob interface. The first returned object does not have a data. The data can be added to the clob object by using `setString` method of the clob interface.
- Exception: If it is already closed, it throws `SQLException`.

## createNClob

NClob `createNClob()` throws `SQLException`

- Operation: It is not implemented.
- Exception: It always throws `SQLFeatureNotSupportedException`.

## createSQLXML

SQLXML `createSQLXML()` throws `SQLException`

- Operation: It is not implemented.
- Exception: It always throws `SQLFeatureNotSupportedException`.

## createStatement

Statement `createStatement()` throws `SQLException`

- Operation: It creates statement object. The `ResultSet` type created by the statement is `ResultSet.TYPE_FORWARD_ONLY`, and concurrency is `ResultSet.CONCUR_READ_ONLY`, and holdability is `ResultSet.HOLD_CURSORS_OVER_COMMIT`.
- Exception: If it is already closed, it throws `SQLException`.

Statement `createStatement(int resultSetType, int resultSetConcurrency)` throws `SQLException`

- Operation: It creates statement object which creates `ResultSet` including the user defined resultset type and resultset concurrency. The holdability of `ResultSet` which are generated from the statement object is as same as the holdability of the connection type. The default holdability of connection is `ResultSet.HOLD_CURSORS_OVER_COMMIT`.
- Exception: If it is already closed, it throws `SQLException`.

Statement `createStatement(int resultSetType, int resultSetConcurrency, int resultSetHoldability)` throws `SQLException`

- Operation: It creates a statement object which creates `ResultSet` including the user defined resultset type, resultset concurrency and holdability.
- Exception: If it is already closed, it throws `SQLException`.

## createStruct

Struct `createStruct(String typeName, Object[] attributes)` throws `SQLException`

- Operation: It is not implemented.
- Exception: It always throws `SQLFeatureNotSupportedException`.

## getAutoCommit

boolean `getAutoCommit()` throws `SQLException`

- Operation: It returns the current auto commit mode. If `setAutoCommit()` has not been called, it returns true.
- Exception: It does not occur.

## getCatalog

String `getCatalog()` throws `SQLException`

- Operation: It gets the current catalog name of the database.
- Exception: If an error occurs from the server or it does not respond, then it throws `SQLException`.

## getClientInfo

Properties `getClientInfo()` throws `SQLException`

- Operation: It returns client information set by the user. If setting information does not exist, It returns null.
- Exception: It does not occur.

String `getClientInfo(String name)` throws `SQLException`

- Operation: It returns specific client information set by the user. If the corresponding information does

not exist, it returns null.

- Exception: It does not occur.

## getHoldability

`int getHoldability()` throws `SQLException`

- Operation: It returns the default holdability value of statements created by this object. The default value is `ResultSet.HOLD_CURSORS_OVER_COMMIT`.
- Exception: It does not occur.

## getMetaData

`DatabaseMetaData getMetaData()` throws `SQLException`

- Operation: It gets a `DatabaseMetaData` object which can be queried for metadata information from this object. It always returns the same object.
- Exception: If it is already closed, it throws `SQLException`.

## getNetworkTimeout

`int getNetworkTimeout()` throws `SQLException`

- Operation: It returns the current network timeout (millisecond). 0 means no limit.
- Exception: If it is already closed, it throws `SQLException`.
- Since: 1.7

## getTransactionIsolation

`int getTransactionIsolation()` throws `SQLException`

- Operation: It gets the transaction isolation level which is set on the current session (connection). The default value which is set on the server is `Connection.TRANSACTION_READ_COMMITTED`.
- Exception: If an error occurs from the server, it throws `SQLException`.

## getTypeMap

`Map<String,Class<?>> getTypeMap()` throws `SQLException`



- Operation: It is not implemented.
- Exception: It always throws `SQLFeatureNotSupportedException`.

## getWarnings

`SQLWarning getWarnings()` throws `SQLException`

- Operation: It returns a warning which the server responds to connection object until now. If a warning does not exist or `clearWarnings()` is already performed, it returns null.
- Exception: It does not occur.

## isClosed

`boolean isClosed()` throws `SQLException`

- Operation: It queries whether `close()` is successfully called. If `close()` is successfully performed, it returns true. Otherwise, it returns false.
- Exception: It does not occur.



This method does not inform a user whether the connection to a physical server is broken. Even if the actual connection is broken it returns true when `close ()` has never been called.

## isReadOnly

`boolean isReadOnly()` throws `SQLException`

- Operation: If the session(connection) is read only mode, it returns true. Otherwise, it returns false. The default value is false. Communication with the server occurs.
- Exception: If an error occurs from the server or it does not respond, it throws `SQLException`.

## isValid

`boolean isValid(int timeout)` throws `SQLException`

- Operation: If `isClosed()` returns true or the heart beat query is sent to the server and response is not successfully received, it returns false. Otherwise, it returns true.
- Exception: It does not occur.

## nativeSQL

String nativeSQL(String sql) throws **SQLException**

- Operation: It returns the native SQL recognized by the server for the given user SQL statement. GOLD ILOCKS always return the value as same as given by the user because the server recognizes the user's SQL statement literally.
- Exception: It does not occur.

## prepareCall

CallableStatement prepareCall(String sql) throws SQLException

- Operation: It returns CallableStatement object for calling stored procedures. ResultSet type created from this CallableStatement is ResultSet.TYPE\_FORWARD\_ONLY, the concurrency is ResultSet.CONCUR\_READ\_ONLY, and the holdability is ResultSet.HOLD\_CURSORS\_OVER\_COMMIT.
- Exception: If it is already closed or the SQL statement is wrong, then it throws SQLException.

CallableStatement prepareCall(String sql, int resultSetType, int resultSetConcurrency) throws SQLException

- Operation: It creates CallableStatement object which creates ResultSet with the resultset type and the resultset concurrency specified by the user. The holdability of ResultSet created from this CallableStatement is as same as that of the connection. The default holdability value of the connection is ResultSet.HOLD\_CURSORS\_OVER\_COMMIT.
- Exception: If it is already closed or the SQL statement is wrong, then it throws SQLException.

CallableStatement prepareCall(String sql, int resultSetType, int resultSetConcurrency, int resultSetHoldability) throws SQLException

- Operation: It creates CallableStatement object which creates ResultSet with the resultset type, the resultset concurrency and the holdability specified by the user.
- Exception: If it is already closed or the SQL statement is wrong, then it throws SQLException.

## prepareStatement

PreparedStatement prepareStatement(String sql) throws SQLException

- Operation: It sends the SQL statement to the server and prepares (parsing, validation, optimization), and it returns the PreparedStatement object which controls the prepared statement to the user. The type of ResultSet generated by the PreparedStatement is ResultSet.TYPE\_FORWARD\_ONLY, and concurrency is ResultSet.CONCUR\_READ\_ONLY, and holdability is ResultSet.HOLD\_CURSORS\_OVER\_CO

MMIT.

- Exception: If it is already closed or the SQL statement is wrong, it throws `SQLException`.

`PreparedStatement prepareStatement(String sql, int autoGeneratedKeys)` throws `SQLException`

- Operation: If `autoGeneratedKeys` is `Statement.NO_GENERATED_KEYS`, it operates in the same way as `prepareStatement(String sql)` method. Otherwise, it throws an exception.
- Exception: If it is already closed, the SQL statement is wrong or `autoGeneratedKeys` value is neither `Statement.NO_GENERATED_KEYS` nor `Statement.RETURN_GENERATED_KEYS`, then it throws `SQLException`. If `autoGeneratedKeys` is `Statement.RETURN_GENERATED_KEYS`, it throws `SQLFeatureNotSupportedException`.

`PreparedStatement prepareStatement(String sql, int[] columnIndexes)` throws `SQLException`

- Operation: If `columnIndexes` is null, it operates in the same way as the `prepareStatement(String sql)` method. Otherwise, it throws an exception.
- Exception: If it is already closed or the SQL statement is wrong, it throws `SQLException`. If `columnIndexes` is not null, it throws `SQLFeatureNotSupportedException`.

`PreparedStatement prepareStatement(String sql, int resultSetType, int resultSetConcurrency)`  
throws `SQLException`

- Operation: It sends the SQL statement to the server and prepares (parsing, validation, optimization). It returns the `PreparedStatement` object which controls the prepared statement to the user. It creates the `PreparedStatement` object generating `ResultSet` which includes the user defined result set type and result set concurrency. The holdability of `ResultSet` which is generated by `PreparedStatement` is as same as the holdability of connection. The default holdability value of connection is `ResultSet.HOLD_CURSORS_OVER_COMMIT`.
- Exception: If it is already closed or the SQL statement is wrong, it throws `SQLException`.

`PreparedStatement prepareStatement(String sql, int resultSetType, int resultSetConcurrency, int resultSetHoldability)` throws `SQLException`

- Operation: It sends the SQL statement to the server and prepares (parsing, validation, optimization). It returns the `PreparedStatement` object which controls the prepared statement to the user. It creates the `PreparedStatement` object generating `ResultSet` which includes the user defined result set type and result set concurrency and holdability.
- Exception: If it is already closed or the SQL statement is wrong, it throws `SQLException`.

`PreparedStatement prepareStatement(String sql, String[] columnNames)` throws `SQLException`

- Operation: If `columnNames` is null, it operates in the same way as `prepareStatement(String sql)` method. Otherwise, it throws an exception.
- Exception: If it is already closed or the SQL statement is wrong, it throws `SQLException`. If `columnNames`

mes is not null, it throws `SQLFeatureNotSupportedException`.

## releaseSavepoint

`void releaseSavepoint(Savepoint savepoint) throws SQLException`

- Operation: It removes the savepoint from the server. It also removes all savepoints after this savepoint.
- Exception: If it is already closed or the savepoint object was already released or it is not the GOLDILO CKS savepoint object, it throws `SQLException`.

## rollback

`void rollback() throws SQLException`

- Operation: If it is non auto commit mode, it rolls back the current transaction.
- Exception: If it is already closed or it is the auto commit mode or an error is returned from the server, it throws `SQLException`.

`void rollback(Savepoint savepoint) throws SQLException`

- Operation: If it is non auto commit mode, it performs partial rollback to the savepoint for the current transaction.
- Exception: If it is already closed or it is the auto commit mode or an error is returned from the server or the savepoint is not valid, it throws `SQLException`.

## setAutoCommit

`void setAutoCommit(boolean autoCommit) throws SQLException`

- Operation: It changes the auto commit mode for the current connection. If the performed transaction exists and the non auto commit mode is changed to the auto commit, it performs commit.
- Exception: It is as same as the exception which may occur during the commit process.

## setCatalog

`void setCatalog(String catalog) throws SQLException`

- Operation: It is not implemented.
- Exception: It always throws `SQLFeatureNotSupportedException`.

## setClientInfo

`void setClientInfo(Properties properties) throws SQLException`

- Operation: It sets the user defined client information. Existing client information is eliminated. It does not affect the server.
- Exception: It does not occur.

`void setClientInfo(String name, String value) throws SQLException`

- Operation: It adds the user defined client information. Existing client information is retained.
- Exception: It does not occur.

## setHoldability

`void setHoldability(int holdability) throws SQLException`

- Operation: It sets the ResultSet holdability which is generated by the statement generated from this object. If the method is not called, the default value is `ResultSet.HOLD_CURSORS_OVER_COMMIT`.
- Exception: It does not occur.

## setNetworkTimeout

`void setNetworkTimeout(Executor executor, int milliseconds) throws SQLException`

- Operation: It sets the maximum time to wait for the connection or the object created from the connection to respond after a request to the database. If it can not get a response, then it is returned together with `SQLException` and the connection object is closed.
- Exception: If it is already closed, or an executor is null, or the millisecond is smaller than 0, then it throws `SQLException`. If a security manager exists and the corresponding `checkPermission` method rejects the `setNetworkTimeout` call, then it throws `SecurityException`.
- Since: 1.7

## setReadOnly

`void setReadOnly(boolean readOnly) throws SQLException`

- Operation: It sets the read only property of the current session (connection). The default value is false.
- Exception: If it is already closed or an error is returned from the server, it throws `SQLException`.

## setSavepoint

Savepoint `setSavepoint()` throws `SQLException`

- Operation: If it is the non auto commit mode, it sets the savepoint for the current transaction. The savepoint name is internally determined.
- Exception: If it is already closed or it is the auto commit mode or an error is returned from the server, it throws `SQLException`.

Savepoint `setSavepoint(String name)` throws `SQLException`

- Operation: If it is the non auto commit mode, it sets the savepoint whose name is specified by the user for the current transaction.
- Exception: If it is already closed or it is the auto commit mode or an error is returned from the server, it throws `SQLException`.

## setTransactionIsolation

`void setTransactionIsolation(int level)` throws `SQLException`

- Operation: It changes the transaction isolation for the current session (connection). The supported value is `Connection.TRANSACTION_READ_COMMITTED`, `Connection.TRANSACTION_READ_UNCOMMITTED`, and `Connection.TRANSACTION_SERIALIZABLE`. `Connection.READ_UNCOMMITTED` is set to `Connection.TRANSACTION_READ_COMMITTED`, and `Connection.TRANSACTION_REPEATABLE_READ` is set to `Connection.TRANSACTION_SERIALIZABLE`.
- Exception: If it is already closed or the level has the wrong value, it throws `SQLException`.

## setTypeMap

`void setTypeMap(Map<String,Class<?>> map)` throws `SQLException`

- Operation: It is not implemented.
- Exception: It always throws `SQLFeatureNotSupportedException`.

## isWrapperFor

`void isWrapperFor(Class<?> iface)` throws `SQLException`

- Operation: It queries whether this object is a class which implements the `iface` interface. If it is, it returns true. Otherwise, it returns false. It does not determine the presence of the wrapper but it only queries only whether the given argument class type is implemented because `GOLDLOCKS` connection o

bject is not the wrapper of any other class.

- Exception: It does not occur.

## unwrap

`<T> T unwrap(Class<T> iface) throws SQLException`

- Operation: It eventually returns itself, even when it is unwrapped because GOLDILOCKS connection is not the wrapper of any other class. It returns itself after casting it to the corresponding type. If `iface` is an argument of `isWrapperFor()` method and `false` is returned, the method throws an exception.
- Exception: If `iface` is not the type of this object (if this object returns the unimplemented type), it throws `SQLException`.

## ConnectionPoolDataSource

### getPooledConnection

`PooledConnection getPooledConnection()` throws `SQLException`

- Operation: It creates the `PooledConnection` object. Various connection information, such as user name, password, connection URL should be set through the setter method in advance.
- Exception: If the connection fails, it throws `SQLException`.

`PooledConnection getPooledConnection(String user, String password)` throws `SQLException`

- Operation: It creates the `PooledConnection` object. Username and password shall comply with the argument. Other connection information should be set to the setter method in advance.
- Exception: If the connection fails, it throws `SQLException`.



## DatabaseMetaData

### allProceduresAreCallable

boolean allProceduresAreCallable() throws SQLException

- Operation: It always returns true.
- Exception: It does not occur.

### allTablesAreSelectable

boolean allTablesAreSelectable() throws SQLException

- Operation: It always returns true.
- Exception: It does not occur.

### autoCommitFailureClosesAllResultSets

boolean autoCommitFailureClosesAllResultSets() throws SQLException

- Operation: It always returns false.
- Exception: It does not occur.

### dataDefinitionCausesTransactionCommit

boolean dataDefinitionCausesTransactionCommit() throws SQLException

- Operation: It always returns false because it does not automatically commit DDL statements at run-time.
- Exception: It does not occur.

### dataDefinitionIgnoredInTransactions

boolean dataDefinitionIgnoredInTransactions() throws SQLException

- Operation: It always returns false, because DDL statements are included in a transaction.
- Exception: It does not occur.

## deletesAreDetected

boolean `deletesAreDetected(int type)` throws `SQLException`

- Operation: If type is `ResultSet.TYPE_SCROLL_SENSITIVE`, it returns true. Otherwise, it returns false.
- Exception: It does not occur.

## doesMaxRowSizeIncludeBlobs

boolean `doesMaxRowSizeIncludeBlobs()` throws `SQLException`

- Operation: It always returns false.
- Exception: It does not occur.

## getAttributes

`ResultSet getAttributes(String catalog, String schemaPattern, String typeNamePattern, String attributeNamePattern)` throws `SQLException`

- Operation: It returns an empty `ResultSet`.
- Exception: If an error is returned from the server, it throws `SQLException`.

## getBestRowIdentifier

`ResultSet getBestRowIdentifier(String catalog, String schema, String table, int scope, boolean nullable)` throws `SQLException`

- Operation: It returns a `ResultSet` including one row consisting with rowid information because the rowid type is supported for all tables. If the table does not exist, it returns an empty `ResultSet`.
- Exception: If the table is null or an error is returned from the server, it throws `SQLException`.

## getCatalogs

`ResultSet getCatalogs()` throws `SQLException`

- Operation: It returns a `ResultSet` which has the catalog name in a column.
- Exception: If an error is returned from the server, it throws `SQLException`.

## getCatalogSeparator

String `getCatalogSeparator()` throws `SQLException`

- Operation: It returns a catalog separator character.
- Exception: If an error is returned from the server, it throws `SQLException`.

## getCatalogTerm

String `getCatalogTerm()` throws `SQLException`

- Operation: It returns a catalog term character.
- Exception: If an error is returned from the server, it throws `SQLException`.

## getClientInfoProperties

`ResultSet` `getClientInfoProperties()` throws `SQLException`

- Operation: It returns a `ResultSet` including client information.
- Exception: If an error is returned from the server, it throws `SQLException`.

## getColumnPrivileges

`ResultSet` `getColumnPrivileges(String catalog, String schema, String table, String columnNamePattern)` throws `SQLException`

- Operation: It returns a `ResultSet` including column privilege information of the column in the table. If the table or the column corresponding to the column name pattern does not exist, it returns an empty `ResultSet`.
- Exception: If an error is returned from the server, it throws `SQLException`.

## getColumns

`ResultSet` `getColumns(String catalog, String schemaPattern, String tableNamePattern, String columnNamePattern)` throws `SQLException`

- Operation: It returns a `ResultSet` including all column information of the table. If the table or the column corresponding to the column name pattern does not exist, it returns an empty `ResultSet`.
- Exception: If an error is returned from the server, it throws `SQLException`.

## getConnection

Connection getConnection() throws SQLException

- Operation: It returns the connection object which created the DatabaseMetaData object.
- Exception: It does not occur.

## getCrossReference

ResultSet getCrossReference(String parentCatalog, String parentSchema, String parentTable, String foreignCatalog, String foreignSchema, String foreignTable) throws SQLException

- Operation: It returns a ResultSet including information of the foreign keys which refers to the given parent table in the given foreign key table. If reference relationship does not exist, it returns an empty ResultSet.
- Exception: If the foreign table or parent table is null or an error is returned from the server, it throws SQLException.

## getDatabaseMajorVersion

int getDatabaseMajorVersion() throws SQLException

- Operation: It returns the major version of the product.
- Exception: If an error is returned from the server, it throws SQLException.

## getDatabaseMinorVersion

int getDatabaseMinorVersion() throws SQLException

- Operation: It returns the minor version of the product.
- Exception: If an error is returned from the server, it throws SQLException.

## getDatabaseProductName

String getDatabaseProductName() throws SQLException

- Operation: It returns the product name.
- Exception: If an error is returned from the server, it throws SQLException.

## getDatabaseProductVersion

String getDatabaseProductVersion() throws SQLException

- Operation: It returns the product version.
- Exception: If an error is returned from the server, it throws SQLException.

## getDefaultTransactionIsolation

int getDefaultTransactionIsolation() throws SQLException

- Operation: It returns the default transaction isolation. The default value which is set on the server is Connection.TRANSACTION\_READ\_COMMITTED.
- Exception: If an error is returned from the server, it throws SQLException.

## getDriverMajorVersion

int getDriverMajorVersion() throws SQLException

- Operation: It returns the major version of GOLDILOCKS JDBC driver.
- Exception: It does not occur.

## getDriverMinorVersion

int getDriverMinorVersion() throws SQLException

- Operation: It returns the minor version of GOLDILOCKS JDBC driver.
- Exception: It does not occur.

## getDriverName

String getDriverName() throws SQLException

- Operation: It returns "GOLDILOCKS JDBC Driver".
- Exception: It does not occur.

## getDriverVersion

String getDriverVersion() throws SQLException

- Operation: It returns GOLDILOCKS JDBC driver version string. It includes the protocol version.
- Exception: It does not occur.

## getExportedKeys

ResultSet getExportedKeys(String catalog, String schema, String table) throws SQLException

- Operation: It returns a ResultSet including foreign key information referring to the column in the given table.
- Exception: If an error is returned from the server, it throws SQLException.

## getExtraNameCharacters

String getExtraNameCharacters() throws SQLException

- Operation: It returns "-\$".
- Exception: It does not occur.

## getFunctionColumns

ResultSet getFunctionColumns(String catalog, String schemaPattern, String functionNamePattern, String columnNamePattern) throws SQLException

- Operation: It returns an empty ResultSet.
- Exception: If an error is returned from the server, it throws SQLException.

## getFunctions

ResultSet getFunctions(String catalog, String schemaPattern, String functionNamePattern) throws SQLException

- Operation: It returns an empty ResultSet.
- Exception: If an error is returned from the server, it throws SQLException.

## getIdentifierQuoteString

`String getIdentifierQuoteString()` throws `SQLException`

- Operation: It returns an identifier quote character. The value that is set on the server is ".
- Exception: If an error is returned from the server, it throws `SQLException`.

## getImportedKeys

`ResultSet getImportedKeys(String catalog, String schema, String table)` throws `SQLException`

- Operation: It returns a `ResultSet` including parent key information to which the foreign key column in the given table refers.
- Exception: If an error is returned from the server, it throws `SQLException`.

## getIndexInfo

`ResultSet getIndexInfo(String catalog, String schema, String table, boolean unique, boolean approximate)` throws `SQLException`

- Operation: It returns a `ResultSet` including index information of the given table. If `unique` is true, only unique index information is displayed. The `approximate` argument is ignored.
- Exception: If an error is returned from the server, it throws `SQLException`.

## getJDBCMajorVersion

`int getJDBCMajorVersion()` throws `SQLException`

- Operation: It returns JDBC major version of GOLDILOCKS JDBC driver. It can vary depending on the jar file in use.
- Exception: It does not occur.

## getJDBCMinorVersion

`int getJDBCMinorVersion()` throws `SQLException`

- Operation: It returns JDBC minor version of GOLDILOCKS JDBC driver. It can vary depending on the jar file in use.
- Exception: It does not occur.

## getMaxBinaryLiteralLength

`int getMaxBinaryLiteralLength() throws SQLException`

- Operation: It gets the maximum binary length from the server. 0 refers that the maximum length is finite.
- Exception: If an error is returned from the server, it throws SQLException.

## getMaxCatalogNameLength

`int getMaxCatalogNameLength() throws SQLException`

- Operation: It gets the maximum length of the catalog name from the server. 0 refers that the maximum length is infinite.
- Exception: If an error is returned from the server, it throws SQLException.

## getMaxCharLiteralLength

`int getMaxCharLiteralLength() throws SQLException`

- Operation: It gets the maximum literal length from the server. 0 refers that the maximum length is infinite.
- Exception: If an error is returned from the server, it throws SQLException.

## getMaxColumnNameLength

`int getMaxColumnNameLength() throws SQLException`

- Operation: It gets the maximum length of the column name from the server. 0 refers that the maximum length is infinite.
- Exception: If an error is returned from the server, it throws SQLException.

## getMaxColumnsInGroupBy

`int getMaxColumnsInGroupBy() throws SQLException`

- Operation: It gets the maximum number of columns available to use in *group by* clause from the server. 0 refers that the maximum number is infinite.
- Exception: If an error is returned from the server, it throws SQLException.



## getMaxColumnsInIndex

`int getMaxColumnsInIndex()` throws `SQLException`

- Operation: It gets the maximum number of columns available to use as the index from the server. 0 refers that the maximum number is infinite.
- Exception: If an error is returned from the server, it throws `SQLException`.

## getMaxColumnsInOrderBy

`int getMaxColumnsInOrderBy()` throws `SQLException`

- Operation: It gets the maximum number of columns available to use in *order by* clause from the server. 0 refers that the maximum number is infinite.
- Exception: If an error is returned from the server, it throws `SQLException`.

## getMaxColumnsInSelect

`int getMaxColumnsInSelect()` throws `SQLException`

- Operation: It gets the maximum number of columns available to use in select target clause from the server. 0 refers that the maximum number is infinite.
- Exception: If an error is returned from the server, it throws `SQLException`.

## getMaxColumnsInTable

`int getMaxColumnsInTable()` throws `SQLException`

- Operation: It gets the maximum number of columns available to use in the table from the server. 0 refers that the maximum number is infinite.
- Exception: If an error is returned from the server, it throws `SQLException`.

## getMaxConnections

`int getMaxConnections()` throws `SQLException`

- Operation: It gets the maximum number of connection to the server from the server. 0 refers that the maximum number is infinite.
- Exception: If an error is returned from the server, it throws `SQLException`.

## getMaxCursorNameLength

`int getMaxCursorNameLength()` throws `SQLException`

- Operation: It gets the maximum length of the cursor name from the server. 0 refers that the maximum length is infinite.
- Exception: If an error is returned from the server, it throws `SQLException`.

## getMaxIndexLength

`int getMaxIndexLength()` throws `SQLException`

- Operation: It gets the maximum size for a single index key from the server.
- Exception: If an error is returned from the server, it throws `SQLException`.



The JDBC specification defines that the available maximum size of a single index is returned in bytes, but its value is meaningless, because index size does not have limit. It operates in this way for it to have the same meaning as ODBC.

## getMaxProcedureNameLength

`int getMaxProcedureNameLength()` throws `SQLException`

- Operation: It gets the maximum length of the procedure name from the server. 0 refers that the maximum length is infinite.
- Exception: If an error is returned from the server, it throws `SQLException`.

## getMaxRowSize

`int getMaxRowSize()` throws `SQLException`

- Operation: It gets the maximum number of rows in a table from the server. 0 refers that the maximum number is infinite.
- Exception: If an error is returned from the server, it throws `SQLException`.

## getMaxSchemaNameLength

`int getMaxSchemaNameLength()` throws `SQLException`

- Operation: It gets the maximum length of the schema name from the server. 0 refers that the maximum length is infinite.
- Exception: If an error is returned from the server, it throws `SQLException`.

## getMaxStatementLength

`int getMaxStatementLength()` throws `SQLException`

- Operation: It gets the maximum string length of an SQL statement from the server. 0 refers that the maximum length is infinite.
- Exception: If an error is returned from the server, it throws `SQLException`.

## getMaxStatements

`int getMaxStatements()` throws `SQLException`

- Operation: It gets the maximum number of statements which can be open at once from the server. 0 refers that the maximum number is infinite.
- Exception: If an error is returned from the server, it throws `SQLException`.

## getMaxTableNameLength

`int getMaxTableNameLength()` throws `SQLException`

- Operation: It gets the maximum string length of the table name from the server. 0 refers that the maximum length is infinite.
- Exception: If an error is returned from the server, it throws `SQLException`.

## getMaxTablesInSelect

`int getMaxTablesInSelect()` throws `SQLException`

- Operation: It gets the maximum number of tables which can be used in the select statement from the server. 0 refers that the maximum number is infinite.
- Exception: If an error is returned from the server, it throws `SQLException`.

## getMaxUserNameLength

`int getMaxUserNameLength() throws SQLException`

- Operation: It gets the maximum string length of the user name from the server. 0 refers that the maximum length is infinite.
- Exception: If an error is returned from the server, it throws SQLException.

## getNumericFunctions

`String getNumericFunctions() throws SQLException`

- Operation: It gets a list of numeric-related functions corresponding to SQL standard from the server. Each function name is distinguished by comma (,).
- Exception: If an error is returned from the server, it throws SQLException.

## getPrimaryKeys

`ResultSet getPrimaryKeys(String catalog, String schema, String table) throws SQLException`

- Operation: It returns a ResultSet including all primary keys in a given table.
- Exception: If an error is returned from the server, it throws SQLException.

## getProcedureColumns

`ResultSet getProcedureColumns(String catalog, String schemaPattern, String procedureNamePattern, String columnNamePattern) throws SQLException`

- Operation: It returns a ResultSet including column information corresponding to the given name pattern for a given procedure.
- Exception: If an error is returned from the server, it throws SQLException.

## getProcedures

`ResultSet getProcedures(String catalog, String schemaPattern, String procedureNamePattern) throws SQLException`

- Operation: It returns a ResultSet including procedure information of a given name pattern.
- Exception: If an error is returned from the server, it throws SQLException.

## getProcedureTerm

String getProcedureTerm() throws SQLException

- Operation: It gets the keyword which refers to the procedure from the server.
- Exception: If an error is returned from the server, it throws SQLException.

## getResultSetHoldability

int getResultSetHoldability() throws SQLException

- Operation: It returns the default holdability property of ResultSet. It is ResultSet.HOLD\_CURSORS\_OVER\_COMMIT.
- Exception: It does not occur.

## getRowIdLifetime

RowIdLifetime getRowIdLifetime() throws SQLException

- Operation: It always returns RowIdLifetime.ROWID\_VALID\_FOREVER.
- Exception: It does not occur.

## getSchemas

ResultSet getSchemas() throws SQLException

- Operation: It returns a ResultSet including information about all schemas in the server.
- Exception: If an error is returned from the server, it throws SQLException.

ResultSet getSchemas(String catalog, String schemaPattern) throws SQLException

- Operation: It returns a ResultSet including information for all schemas which meet the pattern of a given schema name. The catalog is ignored.
- Exception: If an error is returned from the server, it throws SQLException.

## getSchemaTerm

String getSchemaTerm() throws SQLException

- Operation: It gets the keyword which refers to the schema from the server.

- Exception: If an error is returned from the server, it throws SQLException.

## getSearchStringEscape

String getSearchStringEscape() throws SQLException

- Operation: It returns the escape characters used in *like* clause as a string.
- Exception: If an error is returned from the server, it throws SQLException.

## getSQLKeywords

String getSQLKeywords() throws SQLException

- Operation: It returns the keywords which can not be used in SQL statement, separated by comma (,).
- Exception: If an error is returned from the server, it throws SQLException.

## getSQLStateType

int getSQLStateType() throws SQLException

- Operation: It always returns DatabaseMetaData.sqlStateSQL99.
- Exception: It does not occur.

## getStringFunctions

String getStringFunctions() throws SQLException

- Operation: It gets a list of functions which handle the strings and corresponds to SQL standard. Each function name is distinguished by comma (,).
- Exception: If an error is returned from the server, it throws SQLException.

## getSuperTables

ResultSet getSuperTables(String catalog, String schemaPattern, String tableNamePattern) throws SQLException

- Operation: It returns an empty ResultSet.
- Exception: If an error is returned from the server, it throws SQLException.

## getSuperTypes

`ResultSet getSuperTypes(String catalog, String schemaPattern, String typeNamePattern)` throws `SQLException`

- Operation: It returns an empty `ResultSet`.
- Exception: If an error is returned from the server, it throws `SQLException`.

## getSystemFunctions

`String getSystemFunctions()` throws `SQLException`

- Operation: It gets a list of system functions corresponding to SQL standard. Each function name is separated by the comma (,).
- Exception: If an error is returned from the server, it throws `SQLException`.

## getTablePrivileges

`ResultSet getTablePrivileges(String catalog, String schemaPattern, String tableNamePattern)` throws `SQLException`

- Operation: It returns a `ResultSet` including privilege information of all tables which satisfy the condition.
- Exception: If an error is returned from the server, it throws `SQLException`.

## getTables

`ResultSet getTables(String catalog, String schemaPattern, String tableNamePattern, String[] types)` throws `SQLException`

- Operation: It returns a `ResultSet` including information of all tables which satisfy the condition.
- Exception: If an error is returned from the server, it throws `SQLException`.

## getTableTypes

`ResultSet getTableTypes()` throws `SQLException`

- Operation: It returns a `ResultSet` containing information of all table types.
- Exception: If an error is returned from the server, it throws `SQLException`.

## getTimeDateFunctions

String getTimeDateFunctions() throws SQLException

- Operation: It gets functions which are related to time and date and corresponds to SQL standard. Each function name is separated by the comma(,).
- Exception: If an error is returned from the server, it throws SQLException.

## getTypeInfo

ResultSet getTypeInfo() throws SQLException

- Operation: It returns a ResultSet including information of the data type.
- Exception: If an error is returned from the server, it throws SQLException.

## getUDTs

ResultSet getUDTs(String catalog, String schemaPattern, String typeNamePattern, int[] types) throws SQLException

- Operation: It returns an empty ResultSet.
- Exception: If an error is returned from the server, it throws SQLException.

## getURL

String getURL() throws SQLException

- Operation: It returns the URL used to connect to the server.
- Exception: It does not occur.

## getUserName

String getUserName() throws SQLException

- Operation: It returns the current user name which maintains a session.
- Exception: If an error is returned from the server, it throws SQLException.



A user name may be different from the user name used to connect firstly because the user can be changed during a session.



## getVersionColumns

`ResultSet getVersionColumns(String catalog, String schema, String table)` throws `SQLException`

- Operation: It returns an empty `ResultSet`.
- Exception: If an error is returned from the server, it throws `SQLException`.

## insertsAreDetected

`boolean insertsAreDetected(int type)` throws `SQLException`

- Operation: It always returns false regardless of the type.
- Exception: It does not occur.

## isCatalogAtStart

`boolean isCatalogAtStart()` throws `SQLException`

- Operation: It always returns false.
- Exception: It does not occur.

## isReadOnly

`boolean isReadOnly()` throws `SQLException`

- Operation: It gets the information whether the current connection is the read only mode from the server.
- Exception: If an error is returned from the server, it throws `SQLException`.

## locatorsUpdateCopy

`boolean locatorsUpdateCopy()` throws `SQLException`

- Operation: It always returns false.
- Exception: It does not occur.

## nullPlusNonNullsNull

`boolean nullPlusNonNullIsNull()` throws `SQLException`

- Operation: It always returns true.
- Exception: It does not occur.

## nullsAreSortedAtEnd

`boolean nullsAreSortedAtEnd()` throws `SQLException`

- Operation: It always returns false. It does not separately sort null.
- Exception: It does not occur.

## nullsAreSortedAtStart

`boolean nullsAreSortedAtStart()` throws `SQLException`

- Operation: It always returns false. It does not separately sort null.
- Exception: It does not occur.

## nullsAreSortedHigh

`boolean nullsAreSortedHigh()` throws `SQLException`

- Operation: It always returns true. Null is positioned at last by default.
- Exception: It does not occur.

## nullsAreSortedLow

`boolean nullsAreSortedLow()` throws `SQLException`

- Operation: It always returns false. Null is positioned at last by default.
- Exception: It does not occur.

## othersDeletesAreVisible

`boolean othersDeletesAreVisible(int type)` throws `SQLException`

- Operation: If the type is `ResultSet.TYPE_SCROLL_SENSITIVE`, it returns true. Otherwise, it returns false.
- Exception: It does not occur.

## othersInsertsAreVisible

`boolean othersInsertsAreVisible(int type)` throws `SQLException`

- Operation: It always returns false regardless of the type.
- Exception: It does not occur.

## othersUpdatesAreVisible

`boolean othersUpdatesAreVisible(int type)` throws `SQLException`

- Operation: If the type is `ResultSet.TYPE_SCROLL_SENSITIVE`, it returns true. Otherwise, it returns false.
- Exception: It does not occur.

## ownDeletesAreVisible

`boolean ownDeletesAreVisible(int type)` throws `SQLException`

- Operation: If the type is `ResultSet.TYPE_SCROLL_SENSITIVE`, it returns true. Otherwise, it returns false.
- Exception: It does not occur.

## ownInsertsAreVisible

`boolean ownInsertsAreVisible(int type)` throws `SQLException`

- Operation: It always returns false regardless of the type.
- Exception: It does not occur.

## ownUpdatesAreVisible

`boolean ownUpdatesAreVisible(int type)` throws `SQLException`

- Operation: If the type is `ResultSet.TYPE_SCROLL_SENSITIVE`, it returns true. Otherwise, it returns false.
- Exception: It does not occur.

## storesLowerCaseIdentifiers

`boolean storesLowerCaseIdentifiers()` throws `SQLException`

- Operation: It always returns false.
- Exception: It does not occur.

## storesLowerCaseQuotedIdentifiers

`boolean storesLowerCaseQuotedIdentifiers()` throws `SQLException`

- Operation: It always returns false.
- Exception: It does not occur.

## storesMixedCaseIdentifiers

`boolean storesMixedCaseIdentifiers()` throws `SQLException`

- Operation: It always returns false.
- Exception: It does not occur.

## storesMixedCaseQuotedIdentifiers

`boolean storesMixedCaseQuotedIdentifiers()` throws `SQLException`

- Operation: It always returns true.
- Exception: It does not occur.

## storesUpperCaseIdentifiers

`boolean storesUpperCaseIdentifiers()` throws `SQLException`

- Operation: It always returns true.
- Exception: It does not occur.

## storesUpperCaseQuotedIdentifiers

`boolean storesUpperCaseQuotedIdentifiers()` throws `SQLException`

- Operation: It always returns false.
- Exception: It does not occur.

## **supportsAlterTableWithAddColumn**

`boolean supportsAlterTableWithAddColumn()` throws `SQLException`

- Operation: It always returns true.
- Exception: It does not occur.

## **supportsAlterTableWithDropColumn**

`boolean supportsAlterTableWithDropColumn()` throws `SQLException`

- Operation: It always returns true.
- Exception: It does not occur.

## **supportsANSI92EntryLevelSQL**

`boolean supportsANSI92EntryLevelSQL()` throws `SQLException`

- Operation: It always returns false.
- Exception: It does not occur.

## **supportsANSI92FullSQL**

`boolean supportsANSI92FullSQL()` throws `SQLException`

- Operation: It always returns false.
- Exception: It does not occur.

## **supportsANSI92IntermediateSQL**

`boolean supportsANSI92IntermediateSQL()` throws `SQLException`

- Operation: It always returns false.
- Exception: It does not occur.

## supportsBatchUpdates

`boolean supportsBatchUpdates()` throws `SQLException`

- Operation: It always returns true.
- Exception: It does not occur.

## supportsCatalogsInDataManipulation

`boolean supportsCatalogsInDataManipulation()` throws `SQLException`

- Operation: It always returns false.
- Exception: It does not occur.

## supportsCatalogsInIndexDefinitions

`boolean supportsCatalogsInIndexDefinitions()` throws `SQLException`

- Operation: It always returns false.
- Exception: It does not occur.

## supportsCatalogsInPrivilegeDefinitions

`boolean supportsCatalogsInPrivilegeDefinitions()` throws `SQLException`

- Operation: It always returns false.
- Exception: It does not occur.

## supportsCatalogsInProcedureCalls

`boolean supportsCatalogsInProcedureCalls()` throws `SQLException`

- Operation: It always returns false.
- Exception: It does not occur.

## supportsCatalogsInTableDefinitions

`boolean supportsCatalogsInTableDefinitions()` throws `SQLException`

- Operation: It always returns false.
- Exception: It does not occur.

## **supportsColumnAliasing**

`boolean supportsColumnAliasing()` throws `SQLException`

- Operation: It gets information whether to support the column aliasing from the server.
- Exception: If an error is returned from the server, it throws `SQLException`.

## **supportsConvert**

`boolean supportsConvert()` throws `SQLException`

- Operation: It always returns false.
- Exception: It does not occur.

## **supportsConvert**

`boolean supportsConvert(int fromType, int toType)` throws `SQLException`

- Operation: It always returns false.
- Exception: It does not occur.

## **supportsCoreSQLGrammar**

`boolean supportsCoreSQLGrammar()` throws `SQLException`

- Operation: It always returns true.
- Exception: It does not occur.

## **supportsCorrelatedSubqueries**

`boolean supportsCorrelatedSubqueries()` throws `SQLException`

- Operation: It always returns true.
- Exception: It does not occur.

## supportsDataDefinitionAndDataManipulationTransactions

`boolean supportsDataDefinitionAndDataManipulationTransactions()` throws `SQLException`

- Operation: It always returns true. It can perform DML and DDL with a single transaction.
- Exception: It does not occur.

## supportsDataManipulationTransactionsOnly

`boolean supportsDataManipulationTransactionsOnly()` throws `SQLException`

- Operation: It always returns false.
- Exception: It does not occur.

## supportsDifferentTableCorrelationNames

`boolean supportsDifferentTableCorrelationNames()` throws `SQLException`

- Operation: It gets information whether the table correlation name should be different from the table name from the server.
- Exception: If an error is returned from the server, it throws `SQLException`.

## supportsExpressionsInOrderBy

`boolean supportsExpressionsInOrderBy()` throws `SQLException`

- Operation: It gets information whether the calculation can be used in *order by* clause from the server.
- Exception: If an error is returned from the server, it throws `SQLException`.

## supportsExtendedSQLGrammar

`boolean supportsExtendedSQLGrammar()` throws `SQLException`

- Operation: It always returns true.
- Exception: It does not occur.



## supportsFullOuterJoins

`boolean supportsFullOuterJoins()` throws `SQLException`

- Operation: It always returns true.
- Exception: It does not occur.

## supportsGetGeneratedKeys

`boolean supportsGetGeneratedKeys()` throws `SQLException`

- Operation: It always returns false.
- Exception: It does not occur.

## supportsGroupBy

`boolean supportsGroupBy()` throws `SQLException`

- Operation: It always returns true.
- Exception: It does not occur.

## supportsGroupByBeyondSelect

`boolean supportsGroupByBeyondSelect()` throws `SQLException`

- Operation: It always returns true.
- Exception: It does not occur.

## supportsGroupByUnrelated

`boolean supportsGroupByUnrelated()` throws `SQLException`

- Operation: It always returns true.
- Exception: It does not occur.

## supportsIntegrityEnhancementFacility

`boolean supportsIntegrityEnhancementFacility()` throws `SQLException`

- Operation: It gets information whether to support SQL integrity enhancing feature from the server.
- Exception: If an error is returned from the server, it throws `SQLException`.

## **supportsLikeEscapeClause**

`boolean supportsLikeEscapeClause()` throws `SQLException`

- Operation: It gets information whether to support escape clause in like statement from the server.
- Exception: If an error is returned from the server, it throws `SQLException`.

## **supportsLimitedOuterJoins**

`boolean supportsLimitedOuterJoins()` throws `SQLException`

- Operation: It always returns true.
- Exception: It does not occur.

## **supportsMinimumSQLGrammar**

`boolean supportsMinimumSQLGrammar()` throws `SQLException`

- Operation: It always returns true.
- Exception: It does not occur.

## **supportsMixedCaseIdentifiers**

`boolean supportsMixedCaseIdentifiers()` throws `SQLException`

- Operation: It always returns false.
- Exception: It does not occur.

## **supportsMixedCaseQuotedIdentifiers**

`boolean supportsMixedCaseQuotedIdentifiers()` throws `SQLException`

- Operation: It always returns true.
- Exception: It does not occur.

## supportsMultipleOpenResults

boolean supportsMultipleOpenResults() throws SQLException

- Operation: It always returns false.
- Exception: It does not occur.

## supportsMultipleResultSets

boolean supportsMultipleResultSets() throws SQLException

- Operation: It always returns false.
- Exception: It does not occur.

## supportsMultipleTransactions

boolean supportsMultipleTransactions() throws SQLException

- Operation: It always returns true.
- Exception: It does not occur.

## supportsNamedParameters

boolean supportsNamedParameters() throws SQLException

- Operation: It always returns false.
- Exception: It does not occur.

## supportsNonNullableColumns

boolean supportsNonNullableColumns() throws SQLException

- Operation: It always returns true.
- Exception: It does not occur.

## supportsOpenCursorsAcrossCommit

`boolean supportsOpenCursorsAcrossCommit()` throws `SQLException`

- Operation: It always returns true.
- Exception: It does not occur.

## **supportsOpenCursorsAcrossRollback**

`boolean supportsOpenCursorsAcrossRollback()` throws `SQLException`

- Operation: It always returns true.
- Exception: It does not occur.

## **supportsOpenStatementsAcrossCommit**

`boolean supportsOpenStatementsAcrossCommit()` throws `SQLException`

- Operation: It always returns true.
- Exception: It does not occur.

## **supportsOpenStatementsAcrossRollback**

`boolean supportsOpenStatementsAcrossRollback()` throws `SQLException`

- Operation: It always returns true.
- Exception: It does not occur.

## **supportsOrderByUnrelated**

`boolean supportsOrderByUnrelated()` throws `SQLException`

- Operation: It always returns true.
- Exception: It does not occur.

## **supportsOuterJoins**

`boolean supportsOuterJoins()` throws `SQLException`

- Operation: It always returns true.
- Exception: It does not occur.

## supportsPositionedDelete

`boolean supportsPositionedDelete()` throws `SQLException`

- Operation: It always returns false.
- Exception: It does not occur.

## supportsPositionedUpdate

`boolean supportsPositionedUpdate()` throws `SQLException`

- Operation: It always returns false.
- Exception: It does not occur.

## supportsResultSetConcurrency

`boolean supportsResultSetConcurrency(int type, int concurrency)` throws `SQLException`

- Operation: It returns true for all `ResultSet` types and all concurrency. It returns false for the invalid arguments.
- Exception: It does not occur.

## supportsResultSetHoldability

`boolean supportsResultSetHoldability(int holdability)` throws `SQLException`

- Operation: If the holdability is `ResultSet.CLOSE_CURSORS_AT_COMMIT` or `ResultSet.HOLD_CURSORS_S_OVER_COMMIT`, it returns true. Otherwise, it returns false.
- Exception: It does not occur.

## supportsResultSetType

`boolean supportsResultSetType(int type)` throws `SQLException`

- Operation: If the type is `ResultSet.TYPE_FORWARD_ONLY`, `ResultSet.TYPE_SCROLL_INSENSITIVE` or `ResultSet.TYPE_SCROLL_SENSITIVE`, it returns true. Otherwise, it returns false.
- Exception: It does not occur.

## supportsSavepoints

`boolean supportsSavepoints()` throws `SQLException`

- Operation: It always returns true.
- Exception: It does not occur.

## supportsSchemasInDataManipulation

`boolean supportsSchemasInDataManipulation()` throws `SQLException`

- Operation: It always returns true.
- Exception: It does not occur.

## supportsSchemasInIndexDefinitions

`boolean supportsSchemasInIndexDefinitions()` throws `SQLException`

- Operation: It always returns true.
- Exception: It does not occur.

## supportsSchemasInPrivilegeDefinitions

`boolean supportsSchemasInPrivilegeDefinitions()` throws `SQLException`

- Operation: It always returns true.
- Exception: It does not occur.

## supportsSchemasInProcedureCalls

`boolean supportsSchemasInProcedureCalls()` throws `SQLException`

- Operation: It always returns true.
- Exception: It does not occur.

## supportsSchemasInTableDefinitions

`boolean supportsSchemasInTableDefinitions()` throws `SQLException`

- Operation: It always returns true.
- Exception: It does not occur.

## **supportsSelectForUpdate**

`boolean supportsSelectForUpdate()` throws `SQLException`

- Operation: It always returns true.
- Exception: It does not occur.

## **supportsStatementPooling**

`boolean supportsStatementPooling()` throws `SQLException`

- Operation: It always returns true.
- Exception: It does not occur.

## **supportsStoredFunctionsUsingCallSyntax**

`boolean supportsStoredFunctionsUsingCallSyntax()` throws `SQLException`

- Operation: It always returns false.
- Exception: It does not occur.

## **supportsStoredProcedures**

`boolean supportsStoredProcedures()` throws `SQLException`

- Operation: It always returns true.
- Exception: It does not occur.

## **supportsSubqueriesInComparisons**

`boolean supportsSubqueriesInComparisons()` throws `SQLException`

- Operation: It always returns true.
- Exception: It does not occur.

## supportsSubqueriesInExists

`boolean supportsSubqueriesInExists()` throws `SQLException`

- Operation: It always returns true.
- Exception: It does not occur.

## supportsSubqueriesInIns

`boolean supportsSubqueriesInIns()` throws `SQLException`

- Operation: It always returns true.
- Exception: It does not occur.

## supportsSubqueriesInQuantifieds

`boolean supportsSubqueriesInQuantifieds()` throws `SQLException`

- Operation: It always returns true.
- Exception: It does not occur.

## supportsTableCorrelationNames

`boolean supportsTableCorrelationNames()` throws `SQLException`

- Operation: It gets information whether to support the table correlation name from the server.
- Exception: If an error is returned from the server, it throws `SQLException`.

## supportsTransactionIsolationLevel

`boolean supportsTransactionIsolationLevel(int level)` throws `SQLException`

- Operation: It gets information whether to support the transaction isolation level from the server.
- Exception: If an error is returned from the server, it throws `SQLException`.

## supportsTransactions



`boolean supportsTransactions()` throws `SQLException`

- Operation: It always returns true.
- Exception: It does not occur.

## `supportsUnion`

`boolean supportsUnion()` throws `SQLException`

- Operation: It gets information whether to support the union operation from the server.
- Exception: If an error is returned from the server, it throws `SQLException`.

## `supportsUnionAll`

`boolean supportsUnionAll()` throws `SQLException`

- Operation: It gets information whether to support the union all operation from the server.
- Exception: If an error is returned from the server, it throws `SQLException`.

## `updatesAreDetected`

`boolean updatesAreDetected(int type)` throws `SQLException`

- Operation: If the type is `ResultSet.TYPE_SCROLL_SENSITIVE`, it returns true. Otherwise, it returns false.
- Exception: It does not occur.

## `usesLocalFilePerTable`

`boolean usesLocalFilePerTable()` throws `SQLException`

- Operation: It always returns false.
- Exception: It does not occur.

## `usesLocalFiles`

`boolean usesLocalFiles()` throws `SQLException`

- Operation: It always returns false.
- Exception: It does not occur.

## DataSource

### getConnection

Connection getConnection() throws SQLException

- Operation: It opens and returns a new connection object. The information required for connection should be set through a separate non-standard method in advance.
- Exception: If the connection to the server fails, it throws SQLException.

Connection getConnection(String username, String password) throws SQLException

- Operation: It opens and returns a new connection object with the username and password. Other information required for the connection should be set through a separate non-standard method in advance.
- Exception: If the connection to the server fails, it throws SQLException.

### isWrapperFor

boolean isWrapperFor(Class<?> iface) throws SQLException

- Operation: This class is not implemented as the wrapper of any other class. If the object is an instance of iface, it returns true. Otherwise, it returns false.
- Exception: It does not occur.

### unwrap

<T> T unwrap(Class<T> iface) throws SQLException

- Operation: It returns *this* because this class is not implemented as the wrapper of any other class.
- Exception: If the object is not an instance of iface, it throws SQLException.

# Driver

## acceptsURL

`boolean acceptsURL(String url)` throws `SQLException`

- Operation: If the url is not null and it starts with "jdbc:goldilocks:", it returns true. Otherwise, it returns false.
- Exception: It does not occur.

## connect

`Connection connect(String url, Properties info)` throws `SQLException`

- Operation: It creates and returns a new connection object. The url should include the server address, DB name and port.
- Exception: If the url is invalid or the connection from the server fails, it throws `SQLException`.

## getMajorVersion

`int getMajorVersion()` throws `SQLException`

- Operation: It returns the major version of GOLDILOCKS JDBC driver.
- Exception: It does not occur.

## getMinorVersion

`int getMinorVersion()` throws `SQLException`

- Operation: It returns the minor version of GOLDILOCKS JDBC driver.
- Exception: It does not occur.

## getPropertyInfo

`DriverPropertyInfo[] getPropertyInfo(String url, Properties info)` throws `SQLException`

- Operation: It gets the list of available property when GOLDILOCKS JDBC driver is connected.
- Exception: It does not occur.

## **jdbcCompliant**

**|** `boolean jdbcCompliant()` throws `SQLException`

- Operation: It always returns false.
- Exception: It does not occur.

# NClob

This class is not implemented.

## free

| void free() throws SQLException

## getAsciiStream

| InputStream getAsciiStream() throws SQLException

## getCharacterStream

| Reader getCharacterStream() throws SQLException

| Reader getCharacterStream(long pos, long length) throws SQLException

## getSubString

| String getSubString(long pos, int length) throws SQLException

## length

| long length() throws SQLException

## position

| long position(Clob searchstr, long start) throws SQLException

| long position(String searchstr, long start) throws SQLException

## setAsciiStream

| OutputStream setAsciiStream(long pos) throws SQLException

## setCharacterStream

| Writer setCharacterStream(long pos) throws SQLException

## setString

| int setString(long pos, String str) throws SQLException

| int setString(long pos, String str, int offset, int len) throws SQLException

## truncate

| void truncate(long len) throws SQLException

## ParameterMetaData

ParameterMetaData object is returned by `PreparedStatement.getParameterMetaData()`. The parameterMetaData of the GOLDILOCKS JDBC does not use the actual DB information but it is based on the basic type varchar for other information (such as type, etc.) except for in/out. It is because in/out is the only information got from the server on the parameter after prepared. For example, if it is prepared with the query statement which is "Select \* from t1 where a =?", the parameter type used in the condition clause is not determined. The server generally assumes it a varchar type.

### getParameterClassName

`String getParameterClassName(int param)` throws `SQLException`

- Operation: It returns `java.lang.String`. The parameter type is regarded as varchar.
- Exception: If the param value exceeds the range of the number of parameters, it throws `SQLException`.

### getParameterCount

`int getParameterCount()` throws `SQLException`

- Operation: It returns the number of parameters. It is also the number of ? used in the query statement.
- Exception: It does not occur.

### getParameterMode

`int getParameterMode(int param)` throws `SQLException`

- Operation: It returns the in/out mode of the param-th parameter. It returns one of `ParameterMetaData.parameterModeIn`, `ParameterMetaData.parameterModeInOut`, `ParameterMetaData.parameterModeOut`, or `ParameterMetaData.parameterModeUnknown`. The case of returning `parameterModeUnknown` value does not exist until now.
- Exception: If the param value exceeds range of the number of parameters, it throws `SQLException`.

### getParameterType

`int getParameterType(int param) throws SQLException`

- Operation: It returns `Types.VARCHAR` for all parameters.
- Exception: If the param value exceeds range of the number of parameters, it throws `SQLException`.

## getParameterTypeName

`String getParameterTypeName(int param) throws SQLException`

- Operation: It returns "VARCHAR" for all parameters.
- Exception: If the param value exceeds range of the number of parameters, it throws `SQLException`.

## getPrecision

`int getPrecision(int param) throws SQLException`

- Operation: It returns 4000 for all parameters. The parameter is regarded as `varchar(4000)` by default.
- Exception: If the param value exceeds range of the number of parameters, it throws `SQLException`.

## getScale

`int getScale(int param) throws SQLException`

- Operation: It returns 0 for all parameters. The parameter is regarded as `varchar(4000)` by default.
- Exception: If the param value exceeds range of the number of parameters, it throws `SQLException`.

## isNullable

`int isNullable(int param) throws SQLException`

- Operation: It always returns `ParameterMetaData.parameterNullableUnknown`.
- Exception: If the param value exceeds range of the number of parameters, it throws `SQLException`.

## isSigned

`boolean isSigned(int param) throws SQLException`

- Operation: It always returns false.
- Exception: If the param value exceeds range of the number of parameters, it throws `SQLException`.



## isWrapperFor

`boolean isWrapperFor(Class<?> iface) throws SQLException`

- Operation: It enquires if it the object is an instance of iface. If so, it returns true. Otherwise, it returns false.
- Exception: It does not occur.

## unwrap

`<T> T unwrap(Class<T> iface) throws SQLException`

- Operation: If the object is an instance of iface, it casts this object to iface type and returns it.
- Exception: If the object is not an instance of iface, it throws SQLException.

## PooledConnection

### addConnectionEventListener

`void addConnectionEventListener(ConnectionEventListener listener) throws SQLException`

- Operation: It registers the ConnectionEventListener object. After then, if close() of the connection object (logical connection) which is returned from PooledConnection is called or the actual connection is broken, ConnectionEvent is generated to the registered listeners.
- Exception: It does not occur.

### addStatementEventListener

`void addStatementEventListener(StatementEventListener listener) throws SQLException`

- Operation: It does not perform any operation. GOLDILOCKS JDBC driver does not implement the method. Statement pooling feature is performed by the external middleware.
- Exception: It does not occur.

### close

`void close() throws SQLException`

- Operation: It calls close() of the physical connection that the object has.
- Exception: It may occur in close() of physical connection.

### getConnection

`Connection getConnection() throws SQLException`

- Operation: It returns logical connection owned by the object.
- Exception: It does not occur.

### removeConnectionEventListener

`void removeConnectionEventListener(ConnectionEventListener listener) throws SQLException`

- Operation: It removes the registered ConnectionEventListener. After then, ConnectionEvent is not transferred to this listener.

- Exception: It does not occur.

## removeStatementEventListener

`void removeStatementEventListener(StatementEventListener listener) throws SQLException`

- Operation: It does not perform any operation.
- Exception: It does not occur.

# PreparedStatement

## addBatch

`void addBatch()` throws `SQLException`

- Operation: It registers the currently bound data as batch job. If any of this batch job is registered, an error occurs when performing `execute()`, `executeUpdate()`, `executeQuery()` execution. If any one is not bound for the parameter, an error occurs. After `addBatch` if another `addBatch` is performed again at the state without binding with the method of `setXXX()` type, it registers the batch job as the previously bound value.
- Exception: If a parameter which has never been bound exists, it throws an exception.

## clearParameters

`void clearParameters()` throws `SQLException`

- Operation: It removes all of currently bound data and information. But if at least one batch job is registered, operation is not performed.
- Exception: It does not occur.

## execute

`boolean execute()` throws `SQLException`

- Operation: It executes the prepared statement based on the bound data to the current parameter. If the executed statement is the select statement, it returns true and gets a `ResultSet` from the object. Otherwise, it returns false.
- Exception: If the batch job is registered, the bound parameters are insufficient or an error occurs on the server when executing, it throws an exception.

## executeQuery

`ResultSet executeQuery()` throws `SQLException`

- Operation: It executes the prepared statement based on the bound data to the current parameter and fetches, then creates and returns a `ResultSet` object.
- Exception: If the batch job is registered or the bound parameters are insufficient or an error occurs on the server when executing, it throws an exception.

## executeUpdate

`int executeUpdate()` throws `SQLException`

- Operation: It executes the prepared statement based on the bound data to the current parameter. It returns the number of updated records. If updated record with DDL statements does not exist, it returns 0.
- Exception: If the batch job is registered or the statement is not a select statement or the bound parameters are insufficient or an error occurs on the server when executing, it throws an exception.

## getMetaData

`ResultSetMetaData getMetaData()` throws `SQLException`

- Operation: It gets `ResultSetMetaData` object. If the prepared statement is not the select statement (It is the statement which does not return `ResultSet`), it returns an empty `ResultSetMetaData`. The method can be called before executing.
- Exception: If an error occurs on the server, it throws an exception.

## getParameterMetaData

`ParameterMetaData getParameterMetaData()` throws `SQLException`

- Operation: It gets the `ParameterMetaData` object. It can be called before executing. However, all parameters are assumed to be `varchar(4000)` because information about the exact parameter type is not known to the server.
- Exception: If an error occurs on the server, it throws an exception.

## setArray

`void setArray(int parameterIndex, Array x)` throws `SQLException`

- Operation: It is not implemented.
- Exception: It always throws `SQLFeatureNotSupportedException`.

## setAsciiStream

`void setAsciiStream(int parameterIndex, InputStream x)` throws `SQLException`

- Operation: It binds the `InputStream` object to the parameter index as `LONG VARCHAR` type. It does n

ot execute the encoding operation because the input data is a binary form. It does not consider the character set and assumes it as ascii data.

- Exception: It occurs if parameterIndex is smaller than 0 or it is bigger than the number of parameters.



The cost of conversion to VARCHAR occurs in the server because it is bound to LONG VARCHAR. If the length can be known, it is recommended to use void setAsciiStream(int parameterIndex, InputStream x, int length).

`void setAsciiStream(int parameterIndex, InputStream x, int length) throws SQLException`

- Operation: It binds the InputStream object to the parameter index as LONG VARCHAR type. It does not execute the encoding operation because the input data is a binary form. It does not consider the character set and assumes it as ascii data. If English data is inserted or the server client character set environment is identical, this method is faster than setCharacterStream or setString when inserting the data as varchar.
- Exception: It occurs if parameterIndex is smaller than 0 or it is bigger than the number of parameters.

`void setAsciiStream(int parameterIndex, InputStream x, long length) throws SQLException`

- Operation: It binds the InputStream object to the parameter index as LONG VARCHAR type. It does not execute the encoding operation because the input data is a binary form. It does not consider the character set and assumes it as ascii data. If English data is inserted or the server client character set environment is identical, this method is faster than setCharacterStream or setString when inserting the data as varchar.
- Exception: It occurs if parameterIndex is smaller than 0 or it is bigger than the number of parameters.

## setBigDecimal

`void setBigDecimal(int parameterIndex, BigDecimal x) throws SQLException`

- Operation: It binds the BigDecimal object to the parameter index as NUMBER type.
- Exception: It occurs if parameterIndex is smaller than 0 or it is bigger than the number of parameters.

## setBinaryStream

`void setBinaryStream(int parameterIndex, InputStream x) throws SQLException`

- Operation: It binds the InputStream object to the parameter index as LONG VARBINARY type.
- Exception: It occurs if parameterIndex is smaller than 0 or it is bigger than the number of parameters.

`void setBinaryStream(int parameterIndex, InputStream x, int length)` throws `SQLException`

- Operation: It binds the `InputStream` object to the parameter index as `LONG VARBINARY` type.
- Exception: It occurs if `parameterIndex` is smaller than 0 or it is bigger than the number of parameters.

`void setBinaryStream(int parameterIndex, InputStream x, long length)` throws `SQLException`

- Operation: It binds the `InputStream` object to the parameter index as `LONG VARBINARY` type.
- Exception: It occurs if `parameterIndex` is smaller than 0 or it is bigger than the number of parameters.

## setBlob

`void setBlob(int parameterIndex, Blob x)` throws `SQLException`

- Operation: It binds the blob object to the parameter index as `LONG VARBINARY` type.
- Exception: If `parameterIndex` is smaller than 0 or it is bigger than the number of parameters, it throws `SQLException`.

`void setBlob(int parameterIndex, InputStream inputStream)` throws `SQLException`

- Operation: It binds the `InputStream` object to the parameter index as `LONG VARBINARY` type.
- Exception: If `parameterIndex` is smaller than 0 or it is bigger than the number of parameters, it throws `SQLException`.

`void setBlob(int parameterIndex, InputStream inputStream, long length)` throws `SQLException`

- Operation: It binds the `InputStream` object to the parameter index as `LONG VARBINARY` type. The number of characters included in `InputStream` is as many as the `length`.
- Exception: If `parameterIndex` is smaller than 0 or it is bigger than the number of parameters, it throws `SQLException`.

## setBoolean

`void setBoolean(int parameterIndex, boolean x)` throws `SQLException`

- Operation: It binds the data `x` to the parameter index as `BOOLEAN` type.
- Exception: It occurs if `parameterIndex` is smaller than 0 or it is bigger than the number of parameters.

## setByte

`void setByte(int parameterIndex, byte x) throws SQLException`

- Operation: It binds the data `x` to the parameter index as `NATIVE_SMALLINT` type.
- Exception: It occurs if `parameterIndex` is smaller than 0 or it is bigger than the number of parameters.

## setBytes

`void setBytes(int parameterIndex, byte[] x) throws SQLException`

- Operation: It binds the data `x` to the parameter index as `VARBINARY` or `LONG VARBINARY` type. If the length of `x` is equal to or smaller than 4000, it is bound as `VARBINARY`, and if it is bigger than 4000, it is bound as `LONG VARBINARY` type.
- Exception: It occurs if `parameterIndex` is smaller than 0 or it is bigger than the number of parameters.

## setCharacterStream

`void setCharacterStream(int parameterIndex, Reader reader) throws SQLException`

- Operation: It binds the reader object to the parameter index as `LONG VARCHAR` type.
- Exception: It occurs if `parameterIndex` is smaller than 0 or it is bigger than the number of parameters.

`void setCharacterStream(int parameterIndex, Reader reader, int length) throws SQLException`

- Operation: It binds the reader object to the parameter index as `LONG VARCHAR` type.
- Exception: It occurs if `parameterIndex` is smaller than 0 or it is bigger than the number of parameters.

`void setCharacterStream(int parameterIndex, Reader reader, long length) throws SQLException`

- Operation: It binds the reader object to the parameter index as `LONG VARCHAR` type.
- Exception: It occurs if `parameterIndex` is smaller than 0 or it is bigger than the number of parameters.

## setClob

`void setClob(int parameterIndex, Clob x) throws SQLException`

- Operation: It binds the clob object to the parameter index as `LONG VARCHAR` type.
- Exception: If `parameterIndex` is smaller than 0 or it is bigger than the number of parameters, it throws `SQLException`.



`void setClob(int parameterIndex, Reader reader) throws SQLException`

- Operation: It binds the reader object to the parameter index as LONG VARCHAR type.
- Exception: If parameterIndex is smaller than 0 or it is bigger than the number of parameters, it throws SQLException.

`void setClob(int parameterIndex, Reader reader, long length) throws SQLException`

- Operation: It binds the reader object to the parameter index as LONG VARCHAR type. The number of characters included in reader is as many as the length.
- Exception: If parameterIndex is smaller than 0 or it is bigger than the number of parameters, it throws SQLException.

## setDate

`void setDate(int parameterIndex, Date x) throws SQLException`

- Operation: It binds the data x to the parameter index as DATE type. It is equivalent to calling setDate(parameterIndex, x, Calendar.getInstance()). The local timezone is applied.
- Exception: It occurs if parameterIndex is smaller than 0 or it is bigger than the number of parameters.

`void setDate(int parameterIndex, Date x, Calendar cal) throws SQLException`

- Operation: It binds the data x to the parameter index as DATE type. Date x is regarded as timezone of cal.
- Exception: It occurs if parameterIndex is smaller than 0 or it is bigger than the number of parameters.

## setDouble

`void setDouble(int parameterIndex, double x) throws SQLException`

- Operation: It binds the data x to the parameter index as NATIVE\_DOUBLE type.
- Exception: It occurs if parameterIndex is smaller than 0 or it is bigger than the number of parameters.

## setFloat

`void setFloat(int parameterIndex, float x) throws SQLException`

- Operation: It binds the data x to the parameter index as NATIVE\_REAL type.
- Exception: It occurs if parameterIndex is smaller than 0 or it is bigger than the number of parameters.

## setInt

`void setInt(int parameterIndex, int x) throws SQLException`

- Operation: It binds the data `x` to the parameter index as `NATIVE_INTEGER` type.
- Exception: It occurs if `parameterIndex` is smaller than 0 or it is bigger than the number of parameters.

## setLong

`void setLong(int parameterIndex, long x) throws SQLException`

- Operation: It binds the data `x` to the parameter index as `NATIVE_BIGINT` type.
- Exception: It occurs if `parameterIndex` is smaller than 0 or it is bigger than the number of parameters.

## setNCharacterStream

`void setNCharacterStream(int parameterIndex, Reader value) throws SQLException`

- Operation: It is not implemented.
- Exception: It always throws `SQLFeatureNotSupportedException`.

`void setNCharacterStream(int parameterIndex, Reader value, long length) throws SQLException`

- Operation: It is not implemented.
- Exception: It always throws `SQLFeatureNotSupportedException`.

## setNClob

`void setNClob(int parameterIndex, NClob value) throws SQLException`

- Operation: It is not implemented.
- Exception: It always throws `SQLFeatureNotSupportedException`.

`void setNClob(int parameterIndex, Reader reader) throws SQLException`

- Operation: It is not implemented.
- Exception: It always throws `SQLFeatureNotSupportedException`.

`void setNClob(int parameterIndex, Reader reader, long length) throws SQLException`

- Operation: It is not implemented.

- Exception: It always throws `SQLFeatureNotSupportedException`.

## setNString

`void setNString(int parameterIndex, String value) throws SQLException`

- Operation: It is not implemented.
- Exception: It always throws `SQLFeatureNotSupportedException`.

## setNull

`void setNull(int parameterIndex, int sqlType) throws SQLException`

- Operation: It binds null to the parameter index as `GOLDILOCKS` type corresponding to `sqlType`. For more information about `GOLDILOCKS` type mapped to `sqlType`, refer to **Table 32-3 SQL types → GOLDILOCKS types**.
- Exception: It occurs if `parameterIndex` is smaller than 0 or it is bigger than the number of parameters.

`void setNull(int parameterIndex, int sqlType, String typeName) throws SQLException`

- Operation: It binds null to the parameter index as `GOLDILOCKS` type corresponding to `sqlType` type. For more information about `GOLDILOCKS` type mapped to `sqlType`, refer to **Table 32-3 SQL types → GOLDILOCKS types**. The third argument, `typeName`, is ignored because `REF` or the user type is not supported.
- Exception: It occurs if `parameterIndex` is smaller than 0 or it is bigger than the number of parameters.

## setObject

`void setObject(int parameterIndex, Object x) throws SQLException`

- Operation: It binds the data `x` to the parameter index as the mapped `GOLDILOCKS` type.
- Exception: It occurs if `parameterIndex` is smaller than 0 or it is bigger than the number of parameters.

**Table 32-2** Java objects → `GOLDILOCKS` types

Java class	<code>GOLDILOCKS</code> type
<code>null</code>	<code>VARCHAR</code>
<code>Boolean</code>	<code>BOOLEAN</code>
<code>Byte</code>	<code>NATIVE_SMALLINT</code>
<code>Short</code>	<code>NATIVE_SMALLINT</code>
<code>Integer</code>	<code>NATIVE_INTEGER</code>
<code>Long</code>	<code>NATIVE_BIGINT</code>

Java class	GOLDILOCKS type
Float	NATIVE_REAL
Double	NATIVE_DOUBLE
BigInteger	NATIVE_BIGINT
BigDecimal	NUMBER
String	VARCHAR or LONG VARCHAR
byte[]	VARBINARY or LONG VARBINARY
Date	DATE
Time	TIME
Timestamp	TIMESTAMP
Blob	N/A
Clob	N/A
InputStream	LONG VARBINARY
Reader	LONG VARCHAR
GoldilocksInterval	Corresponding INTERVAL type
RowId	ROWID
Others	N/A

`void setObject(int parameterIndex, Object x, int targetSqlType)` throws `SQLException`

- Operation: It binds the data `x` to the parameter index as GOLDILOCKS type corresponding to `targetSqlType`. For more information about GOLDILOCKS type mapped to `targetSqlType`, refer to **Table 32-3 SQL types → GOLDILOCKS types**.
- Exception: It occurs if `parameterIndex` is smaller than 0 or it is greater than the number of parameters.

`void setObject(int parameterIndex, Object x, int targetSqlType, int scaleOrLength)` throws `SQLException`

- Operation: It binds the data `x` to the parameter index as GOLDILOCKS type corresponding to `targetSqlType`. For more information about GOLDILOCKS type mapped to `targetSqlType`, refer to **Table 32-3 SQL types → GOLDILOCKS types**. If `x` is `InputStream` or `Reader` then `scaleOrLength` indicates the data length. For other types this value is ignored.
- Exception: It occurs if `parameterIndex` is smaller than 0 or it is bigger than the number of parameters.

## setRef

`void setRef(int parameterIndex, Ref x)` throws `SQLException`

- Operation: It is not implemented.
- Exception: It always throws `SQLFeatureNotSupportedException`.

## setRowId

`void setRowId(int parameterIndex, RowId x) throws SQLException`

- Operation: It binds the data `x` to the parameter index as ROWID type.
- Exception: It occurs if `parameterIndex` is smaller than 0 or it is bigger than the number of parameters.

## setShort

`void setShort(int parameterIndex, short x) throws SQLException`

- Operation: It binds the data `x` to the parameter index as NATIVE\_SMALLINT type.
- Exception: It occurs if `parameterIndex` is smaller than 0 or it is bigger than the number of parameters.

## setSQLXML

`void setSQLXML(int parameterIndex, SQLXML xmlObject) throws SQLException`

- Operation: It is not implemented.
- Exception: It always throws `SQLFeatureNotSupportedException`.

## setString

`void setString(int parameterIndex, String x) throws SQLException`

- Operation: It binds the data `x` to the parameter index as VARCHAR or LONG VARCHAR type. If the length of `x` is equal to or smaller than 4000, it is bound as VARCHAR, and if it is bigger than 4000, it is bound as LONG VARCHAR type.
- Exception: It occurs if `parameterIndex` is smaller than 0 or it is bigger than the number of parameters.

## setTime

`void setTime(int parameterIndex, Time x) throws SQLException`

- Operation: It binds the data `x` to the parameter index as TIME type. It is equivalent to calling `setTime(parameterIndex, x, Calendar.getInstance())`. The local timezone is applied.
- Exception: It occurs if `parameterIndex` is smaller than 0 or it is bigger than the number of parameters.

`void setTime(int parameterIndex, Time x, Calendar cal) throws SQLException`

- Operation: It binds the data `x` to the parameter index as `TIME` type. Time `x` is regarded as timezone of `cal`.
- Exception: It occurs if `parameterIndex` is smaller than 0 or it is bigger than the number of parameters.

## setTimestamp

`void setTimestamp(int parameterIndex, Timestamp x) throws SQLException`

- Operation: It binds the data `x` to the parameter index as `TIME` type. It is equivalent to calling `setTimestamp(parameterIndex, x, Calendar.getInstance())`. The local timezone is applied.
- Exception: It occurs if `parameterIndex` is smaller than 0 or it is bigger than the number of parameters.

`void setTimestamp(int parameterIndex, Timestamp x, Calendar cal) throws SQLException`

- Operation: It binds the data `x` to the parameter index as `TIMESTAMP` type. Timestamp `x` is regarded as timezone of `cal`.
- Exception: It occurs if `parameterIndex` is smaller than 0 or it is bigger than the number of parameters.

## setUnicodeStream

`void setUnicodeStream(int parameterIndex, InputStream x, int length) throws SQLException`

- Operation: It is not implemented. (It is a deprecated method.)
- Exception: It always throws `SQLFeatureNotSupportedException`.

## setURL

`void setURL(int parameterIndex, URL x) throws SQLException`

- Operation: It is not implemented.
- Exception: It always throws `SQLFeatureNotSupportedException`.

## isWrapperFor

`boolean isWrapperFor(Class<?> iface) throws SQLException`

- Operation: It queries whether this object is the class implementing the `iface` interface. If so, it returns `true`. Otherwise, it returns `false`. It does not determine the presence of the wrapper and it queries only

y whether the given argument class type is implemented because GOLDILOCKS PreparedStatement object is not the wrapper of any other class.

- Exception: It does not occur.

## unwrap

`<T> T unwrap(Class<T> iface) throws SQLException`

- Operation: It eventually returns itself even when it is unwrapped because GOLDILOCKS PreparedStatement is not the wrapper of any other class. It returns after casting to that type. If `iface` is an argument of `isWrapperFor()` method and `false` is returned, the method throws an exception.
- Exception: If `iface` is not this object type (The type which is not implemented by this object is given), it throws `SQLException`.

## executeBatchAtomic

`boolean executeBatchAtomic() throws SQLException`

- Operation: It is identical to `executeBatch()`, but it is atomically executed. The batch job is either entirely succeeded or failed. It is performed faster than `executeBatch()`. If the executed statement is the select statement, it returns `true`, otherwise, it returns `false`.
- Exception: If batch job is not registered or an error occurs on the server, it throws `SQLException`.



It is GOLDILOCKS JDBC-specific feature, and PreparedStatement object can be used after it is casted as GoldilocksPreparedStatement.

e.g. `((GoldilocksPreparedStatement)pstmt).executeBatchAtomic();`

## setTimeTimeZone

`void setTimeTimeZone(int parameterIndex, Time x, Calendar cal) throws SQLException`

- Operation: It binds the data `x` to the parameter index as TIME WITH TIME ZONE type. Time `x` is regarded as timezone of `cal`. Timezone information for DB column refers to timezone of `cal`.
- Exception: It occurs if `parameterIndex` is smaller than 0 or it is bigger than the number of parameters.



It is GOLDILOCKS JDBC-specific feature, and PreparedStatement object can be used after it is casted as GoldilocksPreparedStatement.

e.g. `((GoldilocksPreparedStatement)pstmt).setTimeTimeZone(1, aTime, aCalendar);`

## setTimestampTimeZone

`void setTimestampTimeZone(int parameterIndex, Timestamp x, Calendar cal)` throws `SQLException`

- Operation: It binds the data `x` to the parameter index as `TIMESTAMP WITH TIME ZONE` type. Timestamp `x` is regarded as timezone of `cal`. Timezone information for DB column refers to timezone of `cal`.
- Exception: It occurs if `parameterIndex` is smaller than 0 or it is bigger than the number of parameters.



It is GOLDILOCKS JDBC-specific feature, and `PreparedStatement` object can be used after it is casted as `GoldilocksPreparedStatement`.

e.g. `((GoldilocksPreparedStatement)pstmt).setTimestampTimeZone(1, aTimestamp, aCalendar);`



# Ref

The class is not implemented.

## getBaseTypeName

| String getBaseTypeName() throws SQLException

## getObject

| Object getObject() throws SQLException

| Object getObject(Map<String,Class<?>> map) throws SQLException

## setObject

| void setObject(Object value) throws SQLException

## ResultSet

### absolute

boolean absolute(int row) throws SQLException

- Operation: The fetched row cursor position is at the row-th. The first row is 1. 0 points to the previous first row. If it is a negative number, it points to the last row. -1 points to the last row, and -2 points to the second row from the last row. If the cursor can be positioned within the fetched row cache, only the position information is changed within the cache. If it is not within the cache, it is fetched from the server again. If the row exceeds the range, the cursor is positioned before first or after last, and it returns false. Otherwise, the cursor is positioned at the corresponding row and it returns true.
- Exception: If ResultSet is closed or the ResultSet type is ResultSet.TYPE\_FORWARD\_ONLY or an error occurs from the server when fetching, it throws an exception.



If it is not in the cache, it should be fetched again. If the row is behind the current position, the number of rows(n) from row position are fetched from the server in favor of next(). If the row is prior to the current position, the number of n rows from the position(row-n+1) are fetched from the server in favor of previous().

### afterLast

void afterLast() throws SQLException

- Operation: The row cursor is positioned at *after last*. If the row cache is the last row set (It is a part of the entire result set), only the cursor position is changed. Otherwise, it fetches the last row set (The total number of rows-n + 1 to n rows, n is the number of rows fetched from the server), then positions the cursor at *after last*.
- Exception: If ResultSet is closed or the ResultSet type is ResultSet.TYPE\_FORWARD\_ONLY or an error occurs from the server when fetching, it throws an exception.

### beforeFirst

void beforeFirst() throws SQLException

- Operation: The row cursor is positioned at *before first*. If the row cache is the first row set (It is a part of the entire result set), only the cursor position is changed. Otherwise, it fetches the first row set (1 to n rows, n is the number of rows fetched from the server), then positions the cursor at *before first*.
- Exception: If ResultSet is closed or the ResultSet type is ResultSet.TYPE\_FORWARD\_ONLY or an error occurs from the server when fetching, it throws an exception.

## cancelRowUpdates

`void cancelRowUpdates()` throws `SQLException`

- Operation: Cursor update feature has not been implemented. If `ResultSet` concurrency is `ResultSet.CONCUR_READ_ONLY`, it throws `SQLException`. If it is `ResultSet.CONCUR_UPDATABLE`, it throws `SQLFeatureNotSupportedException`.
- Exception: If it is already closed, it throws `SQLException`. Otherwise, refer to the operation.

## clearWarnings

`void clearWarnings()` throws `SQLException`

- Operation: It clears all `SQLWarning` objects which is owned by `ResultSet` object.
- Exception: It does not occur.

## close

`void close()` throws `SQLException`

- Operation: If the cursor is open on the server, it closes the cursor (If the cursor is already closed on the server, this operation is not performed. Namely, the protocol is not transferred.), and the current state of the `ResultSet` object is changed to be closed. If it is already closed, then any operation is not performed.
- Exception: If an error occurs on the server, it throws `SQLException`.

## deleteRow

`void deleteRow()` throws `SQLException`

- Operation: Cursor update feature is not implemented. If `ResultSet` concurrency is `ResultSet.CONCUR_READ_ONLY`, it throws `SQLException`. If it is `ResultSet.CONCUR_UPDATABLE`, it throws `SQLFeatureNotSupportedException`.
- Exception: If it is already closed, it throws `SQLException`. Otherwise, refer to the operation.

## findColumn

`int findColumn(String columnName)` throws `SQLException`

- Operation: It returns the index of the column name. The index of the first column is 1.

- Exception: If it is already closed or the column name is not found, it throws `SQLException`.

## first

`boolean first()` throws `SQLException`

- Operation: It positions the row cursor at the first (the first row). If the row cache is the first row set (It is a part of the entire result set), only the cursor position is changed. Otherwise, it fetches the first row set (1 to n rows, n is the number of rows fetched from the server), then positions the cursor at the first. If the row exists, it returns true. Otherwise, it returns false.
- Exception: If `ResultSet` is closed or the `ResultSet` type is `ResultSet.TYPE_FORWARD_ONLY` or an error occurs from the server when fetching, it throws an exception.

## getArray

`Array getArray(int columnIndex)` throws `SQLException`

- Operation: Array type is not supported.
- Exception: It always throws `SQLFeatureNotSupportedException`.

`Array getArray(String columnLabel)` throws `SQLException`

- Operation: Array type is not supported. For more information about `GOLDILOCKS` type-specific support, refer to **Table 32-4 Whether supporting getter method for `GOLDILOCKS` type - 1**.
- Exception: It always throws `SQLFeatureNotSupportedException`.

## getAsciiStream

`InputStream getAsciiStream(int columnIndex)` throws `SQLException`

- Operation: It gets the `columnIndex`-th column data as `InputStream` type. For more information about `GOLDILOCKS` type-specific support, refer to **Table 32-4 Whether supporting getter method for `GOLDILOCKS` type - 1**.
- Exception: If `ResultSet` is already closed or the `columnIndex` exceeds the range or the type can not be converted to `InputStream`, it throws `SQLException`.

`InputStream getAsciiStream(String columnLabel)` throws `SQLException`

- Operation: It gets the column data whose name is `columnLabel` as `InputStream` type. For more information about `GOLDILOCKS` type-specific support, refer to **Table 32-4 Whether supporting getter method for `GOLDILOCKS` type - 1**.
- Exception: If `ResultSet` is already closed or the corresponding `columnLabel` does not exist or the type

can not be converted to `InputStream`, it throws `SQLException`.

## getBigDecimal

`BigDecimal getBigDecimal(int columnIndex)` throws `SQLException`

- Operation: It gets the `columnIndex`-th column data as `BigDecimal` type. For more information about GOLDILOCKS type-specific support, refer to **Table 32-4 Whether supporting getter method for GOLDILOCKS type - 1**.
- Exception: If `ResultSet` is already closed or the `columnIndex` exceeds the range or the type can not be converted to `BigDecimal`, it throws `SQLException`.

`BigDecimal getBigDecimal(int columnIndex, int scale)` throws `SQLException`

- Operation: This is a deprecated method. It operates in the same way as `getBigDecimal(int columnIndex)`. The scale is ignored.
- Exception: For more information, refer to **getBigDecimal(int columnIndex)**.

`BigDecimal getBigDecimal(String columnLabel)` throws `SQLException`

- Operation: It gets the column data whose name is `columnLabel` as `BigDecimal` type. For more information about GOLDILOCKS type-specific support, refer to **Table 32-4 Whether supporting getter method for GOLDILOCKS type - 1**.
- Exception: If `ResultSet` is already closed or the corresponding `columnLabel` does not exist or the type can not be converted to `BigDecimal`, it throws `SQLException`.

`BigDecimal getBigDecimal(String columnLabel, int scale)` throws `SQLException`

- Operation: This is a deprecated method. It operates in the same way as `getBigDecimal(String columnLabel)`. The scale is ignored.
- Exception: For more information, refer to **getBigDecimal(String columnLabel)**.

## getBinaryStream

`InputStream getBinaryStream(int columnIndex)` throws `SQLException`

- Operation: It is as same as **getAsciiStream(int columnIndex)**.
- Exception: For more information, refer to **getAsciiStream(int columnIndex)**.

`InputStream getBinaryStream(String columnLabel)` throws `SQLException`

- Operation: It is as same as **getAsciiStream(String columnLabel)**.

- Exception: For more information, refer to `getAsciiStream(String columnName)`.

## getBlob

`Blob getBlob(int columnIndex)` throws `SQLException`

- Operation: It gets the `columnIndex`-th column data as blob type. For more information about GOLDILOCKS type-specific support, refer to **Whether supporting getter method for GOLDILOCKS type - 1**.
- Exception: If `ResultSet` is already closed or the `columnIndex` exceeds the range or the type can not be converted to blob, it throws `SQLException`.

`Blob getBlob(String columnName)` throws `SQLException`

- Operation: It gets the column data whose name is `columnName` as blob type. For more information about GOLDILOCKS type-specific support, refer to **Table 32-4 Whether supporting getter method for GOLDILOCKS type - 1**.
- Exception: If `ResultSet` is already closed or the corresponding `columnName` does not exist or the type can not be converted to blob, it throws `SQLException`.

## getBoolean

`boolean getBoolean(int columnIndex)` throws `SQLException`

- Operation: It gets the `columnIndex`-th column data as Boolean type. For more information about GOLDILOCKS type-specific support, refer to **Table 32-4 Whether supporting getter method for GOLDILOCKS type - 1**.
- Exception: If `ResultSet` is already closed or the `columnIndex` exceeds the range or the type can not be converted to Boolean, it throws `SQLException`.

`boolean getBoolean(String columnName)` throws `SQLException`

- Operation: It gets the column data whose name is `columnName` as Boolean type. For more information about GOLDILOCKS type-specific support, refer to **Table 32-4 Whether supporting getter method for GOLDILOCKS type - 1**.
- Exception: If `ResultSet` is already closed or the corresponding `columnName` does not exist or the type can not be converted to Boolean, it throws `SQLException`.

## getBytes

`byte getByte(int columnIndex)` throws `SQLException`

- Operation: It gets the `columnIndex`-th column data as byte type. For more information about GOLDILOCKS

OCKS type-specific support, refer to **Table 32-4 Whether supporting getter method for GOLDILOCKS type - 1** .

- Exception: If ResultSet is already closed or the columnIndex exceeds the range or the type can not be converted to byte, it throws SQLException.

**byte** `getBytes(String columnLabel)` throws SQLException

- Operation: It gets the column data whose name is columnLabel as byte type. For more information about GOLDILOCKS type-specific support, refer to **Table 32-4 Whether supporting getter method for GOLDILOCKS type - 1** .
- Exception: If ResultSet is already closed or the corresponding columnLabel does not exist or the type can not be converted to byte, it throws SQLException.

## getBytes

**byte[]** `getBytes(int columnIndex)` throws SQLException

- Operation: It gets the columnIndex-th column data as byte[] type. For more information about GOLDILOCKS type-specific support, refer to **Table 32-4 Whether supporting getter method for GOLDILOCKS type - 1** .
- Exception: If ResultSet is already closed or the columnIndex exceeds the range, it throws SQLException.



If getBytes is performed for all GOLDILOCKS data types, it gets the binary form stored in DB.

**byte[]** `getBytes(String columnLabel)` throws SQLException

- Operation: It gets the column data whose name is columnLabel as byte[] type. For more information about GOLDILOCKS type-specific support, refer to **Table 32-4 Whether supporting getter method for GOLDILOCKS type - 1** .
- Exception: If ResultSet is already closed or the corresponding columnLabel does not exist, it throws SQLException.



If getBytes is performed for all GOLDILOCKS data types, it gets the binary form stored in DB.

## getCharacterStream

**Reader** `getCharacterStream(int columnIndex)` throws SQLException

- Operation: It gets the columnIndex-th column data as reader type. For more information about GOLD

LOCKS type-specific support, refer to **Table 32-4 Whether supporting getter method for GOLDILOCKS type - 1**.

- Exception: If ResultSet is already closed or the columnIndex exceeds the range or the type can not be converted to reader, it throws SQLException.

Reader `getCharacterStream(String columnLabel)` throws SQLException

- Operation: It gets the column data whose name is columnLabel as reader type. For more information about GOLDILOCKS type-specific support, refer to **Table 32-4 Whether supporting getter method for GOLDILOCKS type - 1**.
- Exception: If ResultSet is already closed or the corresponding columnLabel does not exist or the type can not be converted to reader, it throws SQLException.

## getClob

Clob `getClob(int columnIndex)` throws SQLException

- Operation: It gets the columnIndex-th column data as clob type. For more information about GOLDILOCKS type-specific support, refer to **Whether supporting getter method for GOLDILOCKS type - 1**.
- Exception: If ResultSet is already closed or the columnIndex exceeds the range or the type can not be converted to clob, it throws SQLException.

Clob `getClob(String columnLabel)` throws SQLException

- Operation: It gets the column data whose name is columnLabel as clob type. For more information about GOLDILOCKS type-specific support, refer to **Whether supporting getter method for GOLDILOCKS type - 1**.
- Exception: If ResultSet is already closed or the corresponding columnLabel does not exist or the type can not be converted to clob, it throws SQLException.

## getConcurrency

int `getConcurrency()` throws SQLException

- Operation: It returns concurrency of the current ResultSet object. It supports only ResultSet.CONCUR\_READ\_ONLY currently.
- Exception: It does not occur.



## getCursorName

String getCursorName() throws SQLException

- Operation: It gets the cursor name of the server pointed by the ResultSet. The communication with the server occurs.
- Exception: If ResultSet is already closed or an error occurs on the server, it throws SQLException.

## getDate

Date getDate(int columnIndex) throws SQLException

- Operation: It gets the columnIndex-th column data as date type. For more information about GOLDILOCKS type-specific support, refer to **Table 32-4 Whether supporting getter method for GOLDILOCKS type - 1**. When creating the date object, local timezone is used.
- Exception: If ResultSet is already closed or the columnIndex exceeds the range or the type can not be converted to date, it throws SQLException.

Date getDate(int columnIndex, Calendar cal) throws SQLException

- Operation: It gets the columnIndex-th column data as date type. For more information about GOLDILOCKS type-specific support, refer to **Table 32-4 Whether supporting getter method for GOLDILOCKS type - 1**. When creating the date object, local timezone of cal is used.
- Exception: If ResultSet is already closed or the columnIndex exceeds the range or the type can not be converted to date, it throws SQLException.

Date getDate(String columnLabel) throws SQLException

- Operation: It gets the column data whose name is columnLabel as date type. For more information about GOLDILOCKS type-specific support, refer to **Table 32-4 Whether supporting getter method for GOLDILOCKS type - 1**. When creating the date object, the local timezone is used.
- Exception: If ResultSet is already closed or the corresponding columnLabel does not exist or the type can not be converted to date, it throws SQLException.

Date getDate(String columnLabel, Calendar cal) throws SQLException

- Operation: It gets the column data whose name is columnLabel as date type. For more information about GOLDILOCKS type-specific support, refer to **Table 32-4 Whether supporting getter method for GOLDILOCKS type - 1**. When creating the date object, the local timezone of cal is used.
- Exception: If ResultSet is already closed or the corresponding columnLabel does not exist or the type can not be converted to date, it throws SQLException.

## getDouble

`double getDouble(int columnIndex) throws SQLException`

- Operation: It gets the columnIndex-th column data as double type. For more information about GOLDILOCKS type-specific support, refer to **Table 32-4 Whether supporting getter method for GOLDILOCKS type - 1**.
- Exception: If ResultSet is already closed or the columnIndex exceeds the range or the type can not be converted to double, it throws SQLException.

`double getDouble(String columnLabel) throws SQLException`

- Operation: It gets the column data whose name is columnLabel as double type. For more information about GOLDILOCKS type-specific support, refer to **Table 32-4 Whether supporting getter method for GOLDILOCKS type - 1**.
- Exception: If ResultSet is already closed or the corresponding columnLabel does not exist or the type can not be converted to double, it throws SQLException.

## getFetchDirection

`int getFetchDirection() throws SQLException`

- Operation: It always returns ResultSet.FETCH\_FORWARD. The backward fetch is not supported.
- Exception: If ResultSet is already closed, it throws SQLException.

## getFetchSize

`int getFetchSize() throws SQLException`

- Operation: It gets the number of rows fetched from the server at once. If it is 0, it calculates the maximum number of rows included in a communication packet per transmission. The default value is 0.
- Exception: If ResultSet is already closed, it throws SQLException.

## getFloat

`float getFloat(int columnIndex) throws SQLException`

- Operation: It gets the columnIndex-th column data as float type. For more information about GOLDILOCKS type-specific support, refer to **Table 32-4 Whether supporting getter method for GOLDILOCKS type - 1**.
- Exception: If ResultSet is already closed or the columnIndex exceeds the range or the type can not be

converted to float, it throws `SQLException`.

`float getFloat(String columnLabel)` throws `SQLException`

- Operation: It gets the column data whose name is `columnLabel` as float type. For more information about `GOLDILOCKS` type-specific support, refer to **Table 32-4 Whether supporting getter method for `GOLDILOCKS` type - 1**.
- Exception: If `ResultSet` is already closed or the corresponding `columnLabel` does not exist or the type can not be converted to float, it throws `SQLException`.

## getHoldability

`int getHoldability()` throws `SQLException`

- Operation: It returns the holdability of the current `ResultSet`. It is the value determined when the `ResultSet` object is created, and it can not be changed in the meantime. The default value is `ResultSet.HOLD_CURSOR_OVER_COMMIT`.
- Exception: If `ResultSet` is already closed, it throws `SQLException`.

## getInt

`int getInt(int columnIndex)` throws `SQLException`

- Operation: It gets the `columnIndex`-th column data as int type. For more information about `GOLDILOCKS` type-specific support, refer to **Table 32-4 Whether supporting getter method for `GOLDILOCKS` type - 1**.
- Exception: If `ResultSet` is already closed or the `columnIndex` exceeds the range or the type can not be converted to int, it throws `SQLException`.

`int getInt(String columnLabel)` throws `SQLException`

- Operation: It gets the column data whose name is `columnLabel` as int type. For more information about `GOLDILOCKS` type-specific support, refer to **Table 32-4 Whether supporting getter method for `GOLDILOCKS` type - 1**.
- Exception: If `ResultSet` is already closed or the corresponding `columnLabel` does not exist or the type can not be converted to int, it throws `SQLException`.

## getLong

`long getLong(int columnIndex)` throws `SQLException`

- Operation: It gets the `columnIndex`-th column data as long type. For more information about `GOLDILOCKS` type-specific support, refer to **Table 32-4 Whether supporting getter method for `GOLDILOCKS` type - 1**.

OCKS type-specific support, refer to **Table 32-4 Whether supporting getter method for GOLDILOCKS type - 1** .

- Exception: If ResultSet is already closed or the columnIndex exceeds the range or the type can not be converted to long, it throws SQLException.

**long getLong(String columnLabel) throws SQLException**

- Operation: It gets the column data whose name is columnLabel as long type. For more information about GOLDILOCKS type-specific support, refer to **Table 32-4 Whether supporting getter method for GOLDILOCKS type - 1** .
- Exception: If ResultSet is already closed or the corresponding columnLabel does not exist or the type can not be converted to long, it throws SQLException.

## getMetaData

**ResultSetMetaData getMetaData() throws SQLException**

- Operation: It creates and returns the ResultSetMetaData object getting detailed information on the column.
- Exception: If ResultSet is already closed or an error occurs while detailed information on the column is fetched from the server, it throws SQLException.

## getNCharacterStream

**Reader getNCharacterStream(int columnIndex) throws SQLException**

- Operation: NCHAR family types are not supported currently.
- Exception: It always throws SQLFeatureNotSupportedException.

**Reader getNCharacterStream(String columnLabel) throws SQLException**

- Operation: NCHAR family types are not supported currently.
- Exception: It always throws SQLFeatureNotSupportedException.

## getNClob

**NClob getNClob(int columnIndex) throws SQLException**

- Operation: NCHAR family types are not supported currently.
- Exception: It always throws SQLFeatureNotSupportedException.

`NClob getNClob(String columnLabel)` throws `SQLException`

- Operation: NCHAR family types are not supported currently.
- Exception: It always throws `SQLFeatureNotSupportedException`.

## getString

`String getString(int columnIndex)` throws `SQLException`

- Operation: NCHAR family types are not supported currently.
- Exception: It always throws `SQLFeatureNotSupportedException`.

`String getString(String columnLabel)` throws `SQLException`

- Operation: NCHAR family types are not supported currently.
- Exception: It always throws `SQLFeatureNotSupportedException`.

## getObject

`Object getObject(int columnIndex)` throws `SQLException`

- Operation: It gets the `columnIndex`-th column data as the most appropriate Java object type. For more information about GOLDILOCKS type-specific support, refer to **Table 32-4 Whether supporting getter method for GOLDILOCKS type - 1**.
- Exception: If `ResultSet` is already closed or the `columnIndex` exceeds the range, it throws `SQLException`.

`Object getObject(int columnIndex, Map<String,Class<?>> map)` throws `SQLException`

- Operation: It is not supported.
- Exception: It always throws `SQLFeatureNotSupportedException`.

`Object getObject(String columnLabel)` throws `SQLException`

- Operation: It gets the column data whose name is `columnLabel` as the most appropriate Java object type. For more information about GOLDILOCKS type-specific support, refer to **Table 32-4 Whether supporting getter method for GOLDILOCKS type - 1**.
- Exception: If `ResultSet` is already closed or the corresponding `columnLabel` does not exist, it throws `SQLException`.

Object getObject(String columnLabel, Map<String,Class<?>> map) throws SQLException

- Operation: It is not supported.
- Exception: It always throws SQLFeatureNotSupportedException.

## getRef

Ref getRef(int columnIndex) throws SQLException

- Operation: REF type is not supported.
- Exception: It always throws SQLFeatureNotSupportedException.

Ref getRef(String columnLabel) throws SQLException

- Operation: REF type is not supported.
- Exception: It always throws SQLFeatureNotSupportedException.

## getRow

int getRow() throws SQLException

- Operation: It returns the cursor position of the current ResultSet object. The first row is 1. If it is *before first*, it returns 0.
- Exception: If ResultSet is already closed, it throws SQLException.

## getRowId

RowId getRowId(int columnIndex) throws SQLException

- Operation: It gets the columnIndex-th column data as RowId type. For more information about GOLDILOCKS type-specific support, refer to **Table 32-4 Whether supporting getter method for GOLDILOCKS type - 1**.
- Exception: If ResultSet is already closed or the columnIndex exceeds the range or the type can not be converted to RowId, it throws SQLException.

RowId getRowId(String columnLabel) throws SQLException

- Operation: It gets the column data whose name is columnLabel as RowId type. For more information about GOLDILOCKS type-specific support, refer to **Table 32-4 Whether supporting getter method for GOLDILOCKS type - 1**.
- Exception: If ResultSet is already closed or the corresponding columnLabel does not exist or the type

can not be converted to RowId, it throws SQLException.

## getShort

short getShort(int columnIndex) throws SQLException

- Operation: It gets the columnIndex-th column data as short type. For more information about GOLDILOCKS type-specific support, refer to **Table 32-4 Whether supporting getter method for GOLDILOCKS type - 1**.
- Exception: If ResultSet is already closed or the columnIndex exceeds the range or the type can not be converted to short, it throws SQLException.

short getShort(String columnName) throws SQLException

- Operation: It gets the column data whose name is columnName as short type. For more information about GOLDILOCKS type-specific support, refer to **Table 32-4 Whether supporting getter method for GOLDILOCKS type - 1**.
- Exception: If ResultSet is already closed or the corresponding columnName does not exist or the type can not be converted to short, it throws SQLException.

## getSQLXML

SQLXML getSQLXML(int columnIndex) throws SQLException

- Operation: SQLXML type is not supported.
- Exception: It always throws SQLFeatureNotSupportedException.

SQLXML getSQLXML(String columnName) throws SQLException

- Operation: SQLXML type is not supported.
- Exception: It always throws SQLFeatureNotSupportedException.

## getStatement

Statement getStatement() throws SQLException

- Operation: It returns the statement object which created the ResultSet object.
- Exception: If ResultSet is already closed, it throws SQLException.

## getString

String getString(int columnIndex) throws SQLException

- Operation: It gets the columnIndex-th column data as string type. For more information about GOLDILOCKS type-specific support, refer to **Table 32-4 Whether supporting getter method for GOLDILOCKS type - 1**. If getString() is performed for BINARY, VARBINARY, LONG VARBINARY, the string of hex code is returned.
- Exception: If ResultSet is already closed or the columnIndex exceeds the range, it throws SQLException.

String getString(String columnLabel) throws SQLException

- Operation: It gets the column data whose name is columnLabel as string. For more information about GOLDILOCKS type-specific support, refer to **Table 32-4 Whether supporting getter method for GOLDILOCKS type - 1**. If getString() is performed for BINARY, VARBINARY, LONG VARBINARY, it returns the string of hex code.
- Exception: If ResultSet is already closed or the corresponding columnLabel does not exist, it throws SQLException.

## getTime

Time getTime(int columnIndex) throws SQLException

- Operation: It gets the columnIndex-th column data as time type. For more information about GOLDILOCKS type-specific support, refer to **Table 32-4 Whether supporting getter method for GOLDILOCKS type - 1**. When creating the time object, local timezone is used.
- Exception: If ResultSet is already closed or the columnIndex exceeds the range or the type can not be converted to time, it throws SQLException.

Time getTime(int columnIndex, Calendar cal) throws SQLException

- Operation: It gets the columnIndex-th column data as time type. For more information about GOLDILOCKS type-specific support, refer to **Table 32-4 Whether supporting getter method for GOLDILOCKS type - 1**. When creating the time object, local timezone of cal is used.
- Exception: If ResultSet is already closed or the columnIndex exceeds the range or the type can not be converted to time, it throws SQLException.

Time getTime(String columnLabel) throws SQLException

- Operation: It gets the column data whose name is columnLabel as time type. For more information about GOLDILOCKS type-specific support, refer to **Table 32-4 Whether supporting getter method for GOLDILOCKS type - 1**. When creating the time object, the local timezone is used.



- Exception: If `ResultSet` is already closed or the corresponding `columnLabel` does not exist or the type can not be converted to time, it throws `SQLException`.

Time `getTime(String columnLabel, Calendar cal)` throws `SQLException`

- Operation: It gets the column data whose name is `columnLabel` as time type. For more information about `GOLDILOCKS` type-specific support, refer to **Table 32-4 Whether supporting getter method for `GOLDILOCKS` type - 1**. When creating the time object, the local timezone is used.
- Exception: If `ResultSet` is already closed or the corresponding `columnLabel` does not exist or the type can not be converted to time, it throws `SQLException`.

## getTimestamp

Timestamp `getTimestamp(int columnIndex)` throws `SQLException`

- Operation: It gets the `columnIndex`-th column data as timestamp type. For more information about `GOLDILOCKS` type-specific support, refer to **Table 32-4 Whether supporting getter method for `GOLDILOCKS` type - 1**. When creating the timestamp object, local timezone is used.
- Exception: If `ResultSet` is already closed or the `columnIndex` exceeds the range or the type can not be converted to timestamp, it throws `SQLException`.

Timestamp `getTimestamp(int columnIndex, Calendar cal)` throws `SQLException`

- Operation: It gets the `columnIndex`-th column data as timestamp type. For more information about `GOLDILOCKS` type-specific support, refer to **Table 32-4 Whether supporting getter method for `GOLDILOCKS` type - 1**. When creating the timestamp object, local timezone of `cal` is used.
- Exception: If `ResultSet` is already closed or the `columnIndex` exceeds the range or the type can not be converted to timestamp, it throws `SQLException`.

Timestamp `getTimestamp(String columnLabel)` throws `SQLException`

- Operation: It gets the column data whose name is `columnLabel` as timestamp type. For more information about `GOLDILOCKS` type-specific support, refer to **Table 32-4 Whether supporting getter method for `GOLDILOCKS` type - 1**. When creating the timestamp object, the local timezone is used.
- Exception: If `ResultSet` is already closed or the corresponding `columnLabel` does not exist or the type can not be converted to timestamp, it throws `SQLException`.

Timestamp `getTimestamp(String columnLabel, Calendar cal)` throws `SQLException`

- Operation: It gets the column data whose name is `columnLabel` as timestamp type. For more information about `GOLDILOCKS` type-specific support, refer to **Table 32-4 Whether supporting getter method for `GOLDILOCKS` type - 1**. When creating the timestamp object, the local timezone of `cal` is used.
- Exception: If `ResultSet` is already closed or the corresponding `columnLabel` does not exist or the type can not be converted to timestamp, it throws `SQLException`.

## getType

`int getType()` throws `SQLException`

- Operation: It returns the current `ResultSet` type. It returns one of `ResultSet.TYPE_FORWARD_ONLY`, `ResultSet.TYPE_SCROLL_INSENSITIVE`, `ResultSet.TYPE_SCROLL_SENSITIVE`.
- Exception: If `ResultSet` is already closed, it throws `SQLException`.

## getUnicodeStream

`InputStream getUnicodeStream(int columnIndex)` throws `SQLException`

- Operation: It is a deprecated method. It is not implemented.
- Exception: It always throws `SQLFeatureNotSupportedException`.

`InputStream getUnicodeStream(String columnLabel)` throws `SQLException`

- Operation: It is a deprecated method. It is not implemented.
- Exception: It always throws `SQLFeatureNotSupportedException`.

## getURL

`URL getURL(int columnIndex)` throws `SQLException`

- Operation: URL type is not supported.
- Exception: It always throws `SQLFeatureNotSupportedException`.

`URL getURL(String columnLabel)` throws `SQLException`

- Operation: URL type is not supported.
- Exception: It always throws `SQLFeatureNotSupportedException`.

## getWarnings

`SQLWarning getWarnings()` throws `SQLException`

- Operation: It returns a list of `SQLWarning` accumulated on the object so far. If it gets a warning from the server, it creates `SQLWarning`. If `clearWarning` is not performed, it continues to be accumulated. If a warning does not occur, null is returned.
- Exception: It does not occur.

## insertRow

void insertRow() throws SQLException

- Operation: Cursor update feature has not yet been implemented. If ResultSet concurrency is ResultSet.CONCUR\_READ\_ONLY, it throws SQLException. If it is ResultSet.CONCUR\_UPDATABLE, it throws SQLFeatureNotSupportedException.
- Exception: If it is already closed, it throws SQLException. Otherwise, refer to the operation.

## isAfterLast

boolean isAfterLast() throws SQLException

- Operation: It queries whether the current cursor position is at *after last*. If so, it returns true. Otherwise, it returns false.
- Exception: If ResultSet is already closed, it throws SQLException.

## isBeforeFirst

boolean isBeforeFirst() throws SQLException

- Operation: It queries whether the current cursor position is at *before first*. If so, it returns true. Otherwise, it returns false.
- Exception: If ResultSet is already closed, it throws SQLException.

## isClosed

boolean isClosed() throws SQLException

- Operation: It queries whether the current ResultSet is closed. If closed, it returns true. Otherwise, it returns false. Even if the user does not call the close, ResultSet can be closed by closing the cursor of the server. It is when, for example, the statement which created the ResultSet is closed, or the transaction is committed when the holdability is ResultSet.CLOSE\_CURSOR\_AT\_COMMIT mode, or an error occurs from the server during fetching.
- Exception: It does not occur.

## isFirst

boolean isFirst() throws SQLException

- Operation: It queries whether the current cursor position is at first (the first row). If so, it returns true. Otherwise, it returns false.
- Exception: If `ResultSet` is already closed, it throws `SQLException`.

## isLast

`boolean isLast()` throws `SQLException`

- Operation: It queries whether the current cursor position is at last (the last row). If so, it returns true. Otherwise, it returns false.
- Exception: If `ResultSet` is already closed, it throws `SQLException`.

## last

`boolean last()` throws `SQLException`

- Operation: The row cursor is positioned at last (the last row). If the row cache is the last row set (It is a part of the entire result set), only the cursor position is changed. Otherwise, the row cursor is positioned at last after the last row set is fetched (row from last-n+1 to the last row, n is the number of rows fetched from the server). If the row exists, it returns true. Otherwise, it returns false.
- Exception: If `ResultSet` is already closed or the `ResultSet` type is `ResultSet.TYPE_FORWARD_ONLY` or an error occurs from the server when fetching, it throws an exception.

## moveToCurrentRow

`void moveToCurrentRow()` throws `SQLException`

- Operation: The cursor update feature has not yet been implemented. If `ResultSet` concurrency is `ResultSet.CONCUR_READ_ONLY`, it throws `SQLException`. If it is `ResultSet.CONCUR_UPDATABLE`, it throws `SQLFeatureNotSupportedException`.
- Exception: If it is already closed, it throws `SQLException`. Otherwise, refer to the operation.

## moveToInsertRow

`void moveToInsertRow()` throws `SQLException`

- Operation: The cursor update feature has not yet been implemented. If `ResultSet` concurrency is `ResultSet.CONCUR_READ_ONLY`, it throws `SQLException`. If it is `ResultSet.CONCUR_UPDATABLE`, it throws `SQLFeatureNotSupportedException`.
- Exception: If it is already closed, it throws `SQLException`. Otherwise, refer to the operation.

## next

boolean next() throws SQLException

- Operation: The row cursor is positioned at the next to the current row. If the current row is the last row of the row cache, the next row cache is fetched from the server. If the row exists, it returns true. Otherwise, it returns false.
- Exception: If ResultSet is already closed or an error occurs from the server when fetching, it throws an exception.

## previous

boolean previous() throws SQLException

- Operation: The row cursor is positioned at the row before the current position. If the current row is the first row of the row cache, the previous row cache (n rows from x-n to x-1, x is the current row index) is fetched from the server. If the row exists, it returns true. Otherwise, it returns false.
- Exception: If ResultSet is already closed or the ResultSet type is ResultSet.TYPE\_FORWARD\_ONLY or an error occurs from the server during fetching, it throws an exception.

## refreshRow

void refreshRow() throws SQLException

- Operation: If ResultSet type is ResultSet.SCROLL\_SENSITIVE, the current row cache is fetched from the server. If any row is changed (by the same transaction or other transactions), it is reflected. If ResultSet type is ResultSet.Scroll\_INSENSITIVE, any operation is not performed.
- Exception: If ResultSet is already closed or the ResultSet type is ResultSet.TYPE\_FORWARD\_ONLY or an error occurs from the server during fetching, it throws an exception.

## relative

boolean relative(int rows) throws SQLException

- Operation: It moves the row cursor from the current cursor position to the position apart as many as the number of rows. If it can be moved within the current row cache, only the cursor position is changed. Otherwise, the cursor is moved after the row cache is fetched from the server. If the position to be moved is backward from the current position (next direction), the row cache is fetched from rows to rows+n-1 (in favor of next). If the position to be moved is forward from the current position (previous direction), the row cache is fetched from rows-n+1 to rows (in favor of previous).
- Exception: If ResultSet is already closed or the ResultSet type is ResultSet.TYPE\_FORWARD\_ONLY or an error occurs from the server when fetching, it throws an exception.

## rowDeleted

boolean rowDeleted() throws SQLException

- Operation: It queries whether the row of the current cursor position is deleted (by the same transaction or other transactions). If deleted, it returns true. Otherwise, it returns false.
- Exception: If ResultSet is already closed or the ResultSet type is ResultSet.TYPE\_FORWARD\_ONLY, it throws an exception.

## rowInserted

boolean rowInserted() throws SQLException

- Operation: It queries whether the row of the current cursor position is inserted (by the same transaction or other transactions). If inserted, it returns true. Otherwise, it returns false.
- Exception: If ResultSet is already closed or the ResultSet type is ResultSet.TYPE\_FORWARD\_ONLY, it throws an exception.

## rowUpdated

boolean rowUpdated() throws SQLException

- Operation: It queries whether the row of the current cursor position is updated (by the same transaction or other transactions). If updated, it returns true. Otherwise, it returns false.
- Exception: If ResultSet is already closed or the ResultSet type is ResultSet.TYPE\_FORWARD\_ONLY, it throws an exception.

## setFetchDirection

void setFetchDirection(int direction) throws SQLException

- Operation: The backward fetch is not supported by the server. Therefore, only ResultSet.FETCH\_FORWARD is available. SQLWarning occurs if other values are inserted.
- Exception: If ResultSet is already closed or the argument does not have the defined value, it throws an exception.

## setFetchSize

void setFetchSize(int rows) throws SQLException

- Operation: It specifies the number of rows fetched from the server at once. 0 refers that the server determines it. If it is 0, it refers to the number of rows of which a communication packet can include at once for the forward only cursor. It is specified as 100 for the scrollable cursor.
- Exception: If `ResultSet` is already closed, it throws an exception.

## updateArray

`void updateArray(int columnIndex, Array x) throws SQLException`

- Operation: The cursor update feature has not yet been implemented. If `ResultSet` concurrency is `ResultSet.CONCUR_READ_ONLY`, it throws `SQLException`. If it is `ResultSet.CONCUR_UPDATABLE`, it throws `SQLFeatureNotSupportedException`.
- Exception: If it is already closed, it throws `SQLException`. Otherwise, refer to the operation.

`void updateArray(String columnLabel, Array x) throws SQLException`

- Operation: The cursor update feature has not yet been implemented. If `ResultSet` concurrency is `ResultSet.CONCUR_READ_ONLY`, it throws `SQLException`. If it is `ResultSet.CONCUR_UPDATABLE`, it throws `SQLFeatureNotSupportedException`.
- Exception: If it is already closed, it throws `SQLException`. Otherwise, refer to the operation.

## updateAsciiStream

`void updateAsciiStream(int columnIndex, InputStream x) throws SQLException`

- Operation: The cursor update feature has not yet been implemented. If `ResultSet` concurrency is `ResultSet.CONCUR_READ_ONLY`, it throws `SQLException`. If it is `ResultSet.CONCUR_UPDATABLE`, it throws `SQLFeatureNotSupportedException`.
- Exception: If it is already closed, it throws `SQLException`. Otherwise, refer to the operation.

`void updateAsciiStream(int columnIndex, InputStream x, int length) throws SQLException`

- Operation: The cursor update feature has not yet been implemented. If `ResultSet` concurrency is `ResultSet.CONCUR_READ_ONLY`, it throws `SQLException`. If it is `ResultSet.CONCUR_UPDATABLE`, it throws `SQLFeatureNotSupportedException`.
- Exception: If it is already closed, it throws `SQLException`. Otherwise, refer to the operation.

`void updateAsciiStream(int columnIndex, InputStream x, long length) throws SQLException`

- Operation: The cursor update feature has not yet been implemented. If `ResultSet` concurrency is `ResultSet.CONCUR_READ_ONLY`, it throws `SQLException`. If it is `ResultSet.CONCUR_UPDATABLE`, it throws `SQLFeatureNotSupportedException`.

- Exception: If it is already closed, it throws `SQLException`. Otherwise, refer to the operation.

`void updateAsciiStream(String columnLabel, InputStream x) throws SQLException`

- Operation: The cursor update feature has not yet been implemented. If `ResultSet` concurrency is `ResultSet.CONCUR_READ_ONLY`, it throws `SQLException`. If it is `ResultSet.CONCUR_UPDATABLE`, it throws `SQLFeatureNotSupportedException`.
- Exception: If it is already closed, it throws `SQLException`. Otherwise, refer to the operation.

`void updateAsciiStream(String columnLabel, InputStream x, int length) throws SQLException`

- Operation: The cursor update feature has not yet been implemented. If `ResultSet` concurrency is `ResultSet.CONCUR_READ_ONLY`, it throws `SQLException`. If it is `ResultSet.CONCUR_UPDATABLE`, it throws `SQLFeatureNotSupportedException`.
- Exception: If it is already closed, it throws `SQLException`. Otherwise, refer to the operation.

`void updateAsciiStream(String columnLabel, InputStream x, long length) throws SQLException`

- Operation: The cursor update feature has not yet been implemented. If `ResultSet` concurrency is `ResultSet.CONCUR_READ_ONLY`, it throws `SQLException`. If it is `ResultSet.CONCUR_UPDATABLE`, it throws `SQLFeatureNotSupportedException`.
- Exception: If it is already closed, it throws `SQLException`. Otherwise, refer to the operation.

## updateBigDecimal

`void updateBigDecimal(int columnIndex, BigDecimal x) throws SQLException`

- Operation: The cursor update feature has not yet been implemented. If `ResultSet` concurrency is `ResultSet.CONCUR_READ_ONLY`, it throws `SQLException`. If it is `ResultSet.CONCUR_UPDATABLE`, it throws `SQLFeatureNotSupportedException`.
- Exception: If it is already closed, it throws `SQLException`. Otherwise, refer to the operation.

`void updateBigDecimal(String columnLabel, BigDecimal x) throws SQLException`

- Operation: The cursor update feature has not yet been implemented. If `ResultSet` concurrency is `ResultSet.CONCUR_READ_ONLY`, it throws `SQLException`. If it is `ResultSet.CONCUR_UPDATABLE`, it throws `SQLFeatureNotSupportedException`.
- Exception: If it is already closed, it throws `SQLException`. Otherwise, refer to the operation.



## updateBinaryStream

`void updateBinaryStream(int columnIndex, InputStream x) throws SQLException`

- Operation: The cursor update feature has not yet been implemented. If `ResultSet` concurrency is `ResultSet.CONCUR_READ_ONLY`, it throws `SQLException`. If it is `ResultSet.CONCUR_UPDATABLE`, it throws `SQLFeatureNotSupportedException`.
- Exception: If it is already closed, it throws `SQLException`. Otherwise, refer to the operation.

`void updateBinaryStream(int columnIndex, InputStream x, int length) throws SQLException`

- Operation: The cursor update feature has not yet been implemented. If `ResultSet` concurrency is `ResultSet.CONCUR_READ_ONLY`, it throws `SQLException`. If it is `ResultSet.CONCUR_UPDATABLE`, it throws `SQLFeatureNotSupportedException`.
- Exception: If it is already closed, it throws `SQLException`. Otherwise, refer to the operation.

`void updateBinaryStream(int columnIndex, InputStream x, long length) throws SQLException`

- Operation: The cursor update feature has not yet been implemented. If `ResultSet` concurrency is `ResultSet.CONCUR_READ_ONLY`, it throws `SQLException`. If it is `ResultSet.CONCUR_UPDATABLE`, it throws `SQLFeatureNotSupportedException`.
- Exception: If it is already closed, it throws `SQLException`. Otherwise, refer to the operation.

`void updateBinaryStream(String columnLabel, InputStream x) throws SQLException`

- Operation: The cursor update feature has not yet been implemented. If `ResultSet` concurrency is `ResultSet.CONCUR_READ_ONLY`, it throws `SQLException`. If it is `ResultSet.CONCUR_UPDATABLE`, it throws `SQLFeatureNotSupportedException`.
- Exception: If it is already closed, it throws `SQLException`. Otherwise, refer to the operation.

`void updateBinaryStream(String columnLabel, InputStream x, int length) throws SQLException`

- Operation: The cursor update feature has not yet been implemented. If `ResultSet` concurrency is `ResultSet.CONCUR_READ_ONLY`, it throws `SQLException`. If it is `ResultSet.CONCUR_UPDATABLE`, it throws `SQLFeatureNotSupportedException`.
- Exception: If it is already closed, it throws `SQLException`. Otherwise, refer to the operation.

`void updateBinaryStream(String columnLabel, InputStream x, long length) throws SQLException`

- Operation: The cursor update feature has not yet been implemented. If `ResultSet` concurrency is `ResultSet.CONCUR_READ_ONLY`, it throws `SQLException`. If it is `ResultSet.CONCUR_UPDATABLE`, it throws `SQLFeatureNotSupportedException`.
- Exception: If it is already closed, it throws `SQLException`. Otherwise, refer to the operation.

## updateBlob

`void updateBlob(int columnIndex, Blob x) throws SQLException`

- Operation: The cursor update feature has not yet been implemented. If `ResultSet` concurrency is `ResultSet.CONCUR_READ_ONLY`, it throws `SQLException`. If it is `ResultSet.CONCUR_UPDATABLE`, it throws `SQLFeatureNotSupportedException`.
- Exception: If it is already closed, it throws `SQLException`. Otherwise, refer to the operation.

`void updateBlob(int columnIndex, InputStream inputStream) throws SQLException`

- Operation: The cursor update feature has not yet been implemented. If `ResultSet` concurrency is `ResultSet.CONCUR_READ_ONLY`, it throws `SQLException`. If it is `ResultSet.CONCUR_UPDATABLE`, it throws `SQLFeatureNotSupportedException`.
- Exception: If it is already closed, it throws `SQLException`. Otherwise, refer to the operation.

`void updateBlob(int columnIndex, InputStream inputStream, long length) throws SQLException`

- Operation: The cursor update feature has not yet been implemented. If `ResultSet` concurrency is `ResultSet.CONCUR_READ_ONLY`, it throws `SQLException`. If it is `ResultSet.CONCUR_UPDATABLE`, it throws `SQLFeatureNotSupportedException`.
- Exception: If it is already closed, it throws `SQLException`. Otherwise, refer to the operation.

`void updateBlob(String columnLabel, Blob x) throws SQLException`

- Operation: The cursor update feature has not yet been implemented. If `ResultSet` concurrency is `ResultSet.CONCUR_READ_ONLY`, it throws `SQLException`. If it is `ResultSet.CONCUR_UPDATABLE`, it throws `SQLFeatureNotSupportedException`.
- Exception: If it is already closed, it throws `SQLException`. Otherwise, refer to the operation.

`void updateBlob(String columnLabel, InputStream inputStream) throws SQLException`

- Operation: The cursor update feature has not yet been implemented. If `ResultSet` concurrency is `ResultSet.CONCUR_READ_ONLY`, it throws `SQLException`. If it is `ResultSet.CONCUR_UPDATABLE`, it throws `SQLFeatureNotSupportedException`.
- Exception: If it is already closed, it throws `SQLException`. Otherwise, refer to the operation.

`void updateBlob(String columnLabel, InputStream inputStream, long length) throws SQLException`

- Operation: The cursor update feature has not yet been implemented. If `ResultSet` concurrency is `ResultSet.CONCUR_READ_ONLY`, it throws `SQLException`. If it is `ResultSet.CONCUR_UPDATABLE`, it throws `SQLFeatureNotSupportedException`.
- Exception: If it is already closed, it throws `SQLException`. Otherwise, refer to the operation.

## updateBoolean

`void updateBoolean(int columnIndex, boolean x) throws SQLException`

- Operation: The cursor update feature has not yet been implemented. If `ResultSet` concurrency is `ResultSet.CONCUR_READ_ONLY`, it throws `SQLException`. If it is `ResultSet.CONCUR_UPDATABLE`, it throws `SQLFeatureNotSupportedException`.
- Exception: If it is already closed, it throws `SQLException`. Otherwise, refer to the operation.

`void updateBoolean(String columnLabel, boolean x) throws SQLException`

- Operation: The cursor update feature has not yet been implemented. If `ResultSet` concurrency is `ResultSet.CONCUR_READ_ONLY`, it throws `SQLException`. If it is `ResultSet.CONCUR_UPDATABLE`, it throws `SQLFeatureNotSupportedException`.
- Exception: If it is already closed, it throws `SQLException`. Otherwise, refer to the operation.

## updateByte

`void updateByte(int columnIndex, byte x) throws SQLException`

- Operation: The cursor update feature has not yet been implemented. If `ResultSet` concurrency is `ResultSet.CONCUR_READ_ONLY`, it throws `SQLException`. If it is `ResultSet.CONCUR_UPDATABLE`, it throws `SQLFeatureNotSupportedException`.
- Exception: If it is already closed, it throws `SQLException`. Otherwise, refer to the operation.

`void updateByte(String columnLabel, byte x) throws SQLException`

- Operation: The cursor update feature has not yet been implemented. If `ResultSet` concurrency is `ResultSet.CONCUR_READ_ONLY`, it throws `SQLException`. If it is `ResultSet.CONCUR_UPDATABLE`, it throws `SQLFeatureNotSupportedException`.
- Exception: If it is already closed, it throws `SQLException`. Otherwise, refer to the operation.

## updateBytes

`void updateBytes(int columnIndex, byte[] x) throws SQLException`

- Operation: The cursor update feature has not yet been implemented. If `ResultSet` concurrency is `ResultSet.CONCUR_READ_ONLY`, it throws `SQLException`. If it is `ResultSet.CONCUR_UPDATABLE`, it throws `SQLFeatureNotSupportedException`.
- Exception: If it is already closed, it throws `SQLException`. Otherwise, refer to the operation.

`void updateBytes(String columnLabel, byte[] x) throws SQLException`

- Operation: The cursor update feature has not yet been implemented. If `ResultSet` concurrency is `ResultSet.CONCUR_READ_ONLY`, it throws `SQLException`. If it is `ResultSet.CONCUR_UPDATABLE`, it throws `SQLFeatureNotSupportedException`.
- Exception: If it is already closed, it throws `SQLException`. Otherwise, refer to the operation.

## updateCharacterStream

`void updateCharacterStream(int columnIndex, Reader x) throws SQLException`

- Operation: The cursor update feature has not yet been implemented. If `ResultSet` concurrency is `ResultSet.CONCUR_READ_ONLY`, it throws `SQLException`. If it is `ResultSet.CONCUR_UPDATABLE`, it throws `SQLFeatureNotSupportedException`.
- Exception: If it is already closed, it throws `SQLException`. Otherwise, refer to the operation.

`void updateCharacterStream(int columnIndex, Reader x, int length) throws SQLException`

- Operation: The cursor update feature has not yet been implemented. If `ResultSet` concurrency is `ResultSet.CONCUR_READ_ONLY`, it throws `SQLException`. If it is `ResultSet.CONCUR_UPDATABLE`, it throws `SQLFeatureNotSupportedException`.
- Exception: If it is already closed, it throws `SQLException`. Otherwise, refer to the operation.

`void updateCharacterStream(int columnIndex, Reader x, long length) throws SQLException`

- Operation: The cursor update feature has not yet been implemented. If `ResultSet` concurrency is `ResultSet.CONCUR_READ_ONLY`, it throws `SQLException`. If it is `ResultSet.CONCUR_UPDATABLE`, it throws `SQLFeatureNotSupportedException`.
- Exception: If it is already closed, it throws `SQLException`. Otherwise, refer to the operation.

`void updateCharacterStream(String columnLabel, Reader reader) throws SQLException`

- Operation: The cursor update feature has not yet been implemented. If `ResultSet` concurrency is `ResultSet.CONCUR_READ_ONLY`, it throws `SQLException`. If it is `ResultSet.CONCUR_UPDATABLE`, it throws `SQLFeatureNotSupportedException`.
- Exception: If it is already closed, it throws `SQLException`. Otherwise, refer to the operation.

`void updateCharacterStream(String columnLabel, Reader reader, int length) throws SQLException`

- Operation: The cursor update feature has not yet been implemented. If `ResultSet` concurrency is `ResultSet.CONCUR_READ_ONLY`, it throws `SQLException`. If it is `ResultSet.CONCUR_UPDATABLE`, it throws `SQLFeatureNotSupportedException`.
- Exception: If it is already closed, it throws `SQLException`. Otherwise, refer to the operation.

`void updateCharacterStream(String columnLabel, Reader reader, long length) throws SQLException`

- Operation: The cursor update feature has not yet been implemented. If `ResultSet` concurrency is `ResultSet.CONCUR_READ_ONLY`, it throws `SQLException`. If it is `ResultSet.CONCUR_UPDATABLE`, it throws `SQLFeatureNotSupportedException`.
- Exception: If it is already closed, it throws `SQLException`. Otherwise, refer to the operation.

## updateClob

`void updateClob(int columnIndex, Clob x) throws SQLException`

- Operation: The cursor update feature has not yet been implemented. If `ResultSet` concurrency is `ResultSet.CONCUR_READ_ONLY`, it throws `SQLException`. If it is `ResultSet.CONCUR_UPDATABLE`, it throws `SQLFeatureNotSupportedException`.
- Exception: If it is already closed, it throws `SQLException`. Otherwise, refer to the operation.

`void updateClob(int columnIndex, Reader reader) throws SQLException`

- Operation: The cursor update feature has not yet been implemented. If `ResultSet` concurrency is `ResultSet.CONCUR_READ_ONLY`, it throws `SQLException`. If it is `ResultSet.CONCUR_UPDATABLE`, it throws `SQLFeatureNotSupportedException`.
- Exception: If it is already closed, it throws `SQLException`. Otherwise, refer to the operation.

`void updateClob(int columnIndex, Reader reader, long length) throws SQLException`

- Operation: The cursor update feature has not yet been implemented. If `ResultSet` concurrency is `ResultSet.CONCUR_READ_ONLY`, it throws `SQLException`. If it is `ResultSet.CONCUR_UPDATABLE`, it throws `SQLFeatureNotSupportedException`.
- Exception: If it is already closed, it throws `SQLException`. Otherwise, refer to the operation.

`void updateClob(String columnLabel, Clob x) throws SQLException`

- Operation: The cursor update feature has not yet been implemented. If `ResultSet` concurrency is `ResultSet.CONCUR_READ_ONLY`, it throws `SQLException`. If it is `ResultSet.CONCUR_UPDATABLE`, it throws `SQLFeatureNotSupportedException`.
- Exception: If it is already closed, it throws `SQLException`. Otherwise, refer to the operation.

`void updateClob(String columnLabel, Reader reader) throws SQLException`

- Operation: The cursor update feature has not yet been implemented. If `ResultSet` concurrency is `ResultSet.CONCUR_READ_ONLY`, it throws `SQLException`. If it is `ResultSet.CONCUR_UPDATABLE`, it throws `SQLFeatureNotSupportedException`.
- Exception: If it is already closed, it throws `SQLException`. Otherwise, refer to the operation.

`void updateClob(String columnLabel, Reader reader, long length) throws SQLException`

- Operation: The cursor update feature has not yet been implemented. If `ResultSet` concurrency is `ResultSet.CONCUR_READ_ONLY`, it throws `SQLException`. If it is `ResultSet.CONCUR_UPDATABLE`, it throws `SQLFeatureNotSupportedException`.
- Exception: If it is already closed, it throws `SQLException`. Otherwise, refer to the operation.

## updateDate

`void updateDate(int columnIndex, Date x) throws SQLException`

- Operation: The cursor update feature has not yet been implemented. If `ResultSet` concurrency is `ResultSet.CONCUR_READ_ONLY`, it throws `SQLException`. If it is `ResultSet.CONCUR_UPDATABLE`, it throws `SQLFeatureNotSupportedException`.
- Exception: If it is already closed, it throws `SQLException`. Otherwise, refer to the operation.

`void updateDate(String columnLabel, Date x) throws SQLException`

- Operation: The cursor update feature has not yet been implemented. If `ResultSet` concurrency is `ResultSet.CONCUR_READ_ONLY`, it throws `SQLException`. If it is `ResultSet.CONCUR_UPDATABLE`, it throws `SQLFeatureNotSupportedException`.
- Exception: If it is already closed, it throws `SQLException`. Otherwise, refer to the operation.

## updateDouble

`void updateDouble(int columnIndex, double x) throws SQLException`

- Operation: The cursor update feature has not yet been implemented. If `ResultSet` concurrency is `ResultSet.CONCUR_READ_ONLY`, it throws `SQLException`. If it is `ResultSet.CONCUR_UPDATABLE`, it throws `SQLFeatureNotSupportedException`.
- Exception: If it is already closed, it throws `SQLException`. Otherwise, refer to the operation.

`void updateDouble(String columnLabel, double x) throws SQLException`

- Operation: The cursor update feature has not yet been implemented. If `ResultSet` concurrency is `ResultSet.CONCUR_READ_ONLY`, it throws `SQLException`. If it is `ResultSet.CONCUR_UPDATABLE`, it throws `SQLFeatureNotSupportedException`.
- Exception: If it is already closed, it throws `SQLException`. Otherwise, refer to the operation.

## updateFloat

`void updateFloat(int columnIndex, float x) throws SQLException`

- Operation: The cursor update feature has not yet been implemented. If `ResultSet` concurrency is `ResultSet.CONCUR_READ_ONLY`, it throws `SQLException`. If it is `ResultSet.CONCUR_UPDATABLE`, it throws `SQLFeatureNotSupportedException`.
- Exception: If it is already closed, it throws `SQLException`. Otherwise, refer to the operation.

`void updateFloat(String columnLabel, float x) throws SQLException`

- Operation: The cursor update feature has not yet been implemented. If `ResultSet` concurrency is `ResultSet.CONCUR_READ_ONLY`, it throws `SQLException`. If it is `ResultSet.CONCUR_UPDATABLE`, it throws `SQLFeatureNotSupportedException`.
- Exception: If it is already closed, it throws `SQLException`. Otherwise, refer to the operation.

## updateInt

`void updateInt(int columnIndex, int x) throws SQLException`

- Operation: The cursor update feature has not yet been implemented. If `ResultSet` concurrency is `ResultSet.CONCUR_READ_ONLY`, it throws `SQLException`. If it is `ResultSet.CONCUR_UPDATABLE`, it throws `SQLFeatureNotSupportedException`.
- Exception: If it is already closed, it throws `SQLException`. Otherwise, refer to the operation.

`void updateInt(String columnLabel, int x) throws SQLException`

- Operation: The cursor update feature has not yet been implemented. If `ResultSet` concurrency is `ResultSet.CONCUR_READ_ONLY`, it throws `SQLException`. If it is `ResultSet.CONCUR_UPDATABLE`, it throws `SQLFeatureNotSupportedException`.
- Exception: If it is already closed, it throws `SQLException`. Otherwise, refer to the operation.

## updateLong

`void updateLong(int columnIndex, long x) throws SQLException`

- Operation: The cursor update feature has not yet been implemented. If `ResultSet` concurrency is `ResultSet.CONCUR_READ_ONLY`, it throws `SQLException`. If it is `ResultSet.CONCUR_UPDATABLE`, it throws `SQLFeatureNotSupportedException`.
- Exception: If it is already closed, it throws `SQLException`. Otherwise, refer to the operation.

`void updateLong(String columnLabel, long x) throws SQLException`

- Operation: The cursor update feature has not yet been implemented. If `ResultSet` concurrency is `ResultSet.CONCUR_READ_ONLY`, it throws `SQLException`. If it is `ResultSet.CONCUR_UPDATABLE`, it throws `SQLFeatureNotSupportedException`.
- Exception: If it is already closed, it throws `SQLException`. Otherwise, refer to the operation.

## updateNCharacterStream

`void updateNCharacterStream(int columnIndex, Reader x) throws SQLException`

- Operation: The cursor update feature has not yet been implemented. If `ResultSet` concurrency is `ResultSet.CONCUR_READ_ONLY`, it throws `SQLException`. If it is `ResultSet.CONCUR_UPDATABLE`, it throws `SQLFeatureNotSupportedException`.
- Exception: If it is already closed, it throws `SQLException`. Otherwise, refer to the operation.

`void updateNCharacterStream(int columnIndex, Reader x, long length) throws SQLException`

- Operation: The cursor update feature has not yet been implemented. If `ResultSet` concurrency is `ResultSet.CONCUR_READ_ONLY`, it throws `SQLException`. If it is `ResultSet.CONCUR_UPDATABLE`, it throws `SQLFeatureNotSupportedException`.
- Exception: If it is already closed, it throws `SQLException`. Otherwise, refer to the operation.

`void updateNCharacterStream(String columnLabel, Reader reader) throws SQLException`

- Operation: The cursor update feature has not yet been implemented. If `ResultSet` concurrency is `ResultSet.CONCUR_READ_ONLY`, it throws `SQLException`. If it is `ResultSet.CONCUR_UPDATABLE`, it throws `SQLFeatureNotSupportedException`.
- Exception: If it is already closed, it throws `SQLException`. Otherwise, refer to the operation.

`void updateNCharacterStream(String columnLabel, Reader reader, long length) throws SQLException`

- Operation: The cursor update feature has not yet been implemented. If `ResultSet` concurrency is `ResultSet.CONCUR_READ_ONLY`, it throws `SQLException`. If it is `ResultSet.CONCUR_UPDATABLE`, it throws `SQLFeatureNotSupportedException`.
- Exception: If it is already closed, it throws `SQLException`. Otherwise, refer to the operation.

## updateNClob

`void updateNClob(int columnIndex, NClob nClob) throws SQLException`



- Operation: The cursor update feature has not yet been implemented. If `ResultSet` concurrency is `ResultSet.CONCUR_READ_ONLY`, it throws `SQLException`. If it is `ResultSet.CONCUR_UPDATABLE`, it throws `SQLFeatureNotSupportedException`.
- Exception: If it is already closed, it throws `SQLException`. Otherwise, refer to the operation.

`void updateNClob(int columnIndex, Reader reader) throws SQLException`

- Operation: The cursor update feature has not yet been implemented. If `ResultSet` concurrency is `ResultSet.CONCUR_READ_ONLY`, it throws `SQLException`. If it is `ResultSet.CONCUR_UPDATABLE`, it throws `SQLFeatureNotSupportedException`.
- Exception: If it is already closed, it throws `SQLException`. Otherwise, refer to the operation.

`void updateNClob(int columnIndex, Reader reader, long length) throws SQLException`

- Operation: The cursor update feature has not yet been implemented. If `ResultSet` concurrency is `ResultSet.CONCUR_READ_ONLY`, it throws `SQLException`. If it is `ResultSet.CONCUR_UPDATABLE`, it throws `SQLFeatureNotSupportedException`.
- Exception: If it is already closed, it throws `SQLException`. Otherwise, refer to the operation.

`void updateNClob(String columnLabel, NClob nClob) throws SQLException`

- Operation: The cursor update feature has not yet been implemented. If `ResultSet` concurrency is `ResultSet.CONCUR_READ_ONLY`, it throws `SQLException`. If it is `ResultSet.CONCUR_UPDATABLE`, it throws `SQLFeatureNotSupportedException`.
- Exception: If it is already closed, it throws `SQLException`. Otherwise, refer to the operation.

`void updateNClob(String columnLabel, Reader reader) throws SQLException`

- Operation: The cursor update feature has not yet been implemented. If `ResultSet` concurrency is `ResultSet.CONCUR_READ_ONLY`, it throws `SQLException`. If it is `ResultSet.CONCUR_UPDATABLE`, it throws `SQLFeatureNotSupportedException`.
- Exception: If it is already closed, it throws `SQLException`. Otherwise, refer to the operation.

`void updateNClob(String columnLabel, Reader reader, long length) throws SQLException`

- Operation: The cursor update feature has not yet been implemented. If `ResultSet` concurrency is `ResultSet.CONCUR_READ_ONLY`, it throws `SQLException`. If it is `ResultSet.CONCUR_UPDATABLE`, it throws `SQLFeatureNotSupportedException`.
- Exception: If it is already closed, it throws `SQLException`. Otherwise, refer to the operation.

## updateNString

`void updateNString(int columnIndex, String nString) throws SQLException`

- Operation: The cursor update feature has not yet been implemented. If `ResultSet` concurrency is `ResultSet.CONCUR_READ_ONLY`, it throws `SQLException`. If it is `ResultSet.CONCUR_UPDATABLE`, it throws `SQLFeatureNotSupportedException`.
- Exception: If it is already closed, it throws `SQLException`. Otherwise, refer to the operation.

`void updateNString(String columnLabel, String nString) throws SQLException`

- Operation: The cursor update feature has not yet been implemented. If `ResultSet` concurrency is `ResultSet.CONCUR_READ_ONLY`, it throws `SQLException`. If it is `ResultSet.CONCUR_UPDATABLE`, it throws `SQLFeatureNotSupportedException`.
- Exception: If it is already closed, it throws `SQLException`. Otherwise, refer to the operation.

## updateNull

`void updateNull(int columnIndex) throws SQLException`

- Operation: The cursor update feature has not yet been implemented. If `ResultSet` concurrency is `ResultSet.CONCUR_READ_ONLY`, it throws `SQLException`. If it is `ResultSet.CONCUR_UPDATABLE`, it throws `SQLFeatureNotSupportedException`.
- Exception: If it is already closed, it throws `SQLException`. Otherwise, refer to the operation.

`void updateNull(String columnLabel) throws SQLException`

- Operation: The cursor update feature has not yet been implemented. If `ResultSet` concurrency is `ResultSet.CONCUR_READ_ONLY`, it throws `SQLException`. If it is `ResultSet.CONCUR_UPDATABLE`, it throws `SQLFeatureNotSupportedException`.
- Exception: If it is already closed, it throws `SQLException`. Otherwise, refer to the operation.

## updateObject

`void updateObject(int columnIndex, Object x) throws SQLException`

- Operation: The cursor update feature has not yet been implemented. If `ResultSet` concurrency is `ResultSet.CONCUR_READ_ONLY`, it throws `SQLException`. If it is `ResultSet.CONCUR_UPDATABLE`, it throws `SQLFeatureNotSupportedException`.
- Exception: If it is already closed, it throws `SQLException`. Otherwise, refer to the operation.

`void updateObject(int columnIndex, Object x, int scaleOrLength) throws SQLException`

- Operation: The cursor update feature has not yet been implemented. If `ResultSet` concurrency is `ResultSet.CONCUR_READ_ONLY`, it throws `SQLException`. If it is `ResultSet.CONCUR_UPDATABLE`, it throws `SQLFeatureNotSupportedException`.
- Exception: If it is already closed, it throws `SQLException`. Otherwise, refer to the operation.

`void updateObject(String columnLabel, Object x) throws SQLException`

- Operation: The cursor update feature has not yet been implemented. If `ResultSet` concurrency is `ResultSet.CONCUR_READ_ONLY`, it throws `SQLException`. If it is `ResultSet.CONCUR_UPDATABLE`, it throws `SQLFeatureNotSupportedException`.
- Exception: If it is already closed, it throws `SQLException`. Otherwise, refer to the operation.

`void updateObject(String columnLabel, Object x, int scaleOrLength) throws SQLException`

- Operation: The cursor update feature has not yet been implemented. If `ResultSet` concurrency is `ResultSet.CONCUR_READ_ONLY`, it throws `SQLException`. If it is `ResultSet.CONCUR_UPDATABLE`, it throws `SQLFeatureNotSupportedException`.
- Exception: If it is already closed, it throws `SQLException`. Otherwise, refer to the operation.

## updateRef

`void updateRef(int columnIndex, Ref x) throws SQLException`

- Operation: The cursor update feature has not yet been implemented. If `ResultSet` concurrency is `ResultSet.CONCUR_READ_ONLY`, it throws `SQLException`. If it is `ResultSet.CONCUR_UPDATABLE`, it throws `SQLFeatureNotSupportedException`.
- Exception: If it is already closed, it throws `SQLException`. Otherwise, refer to the operation.

`void updateRef(String columnLabel, Ref x) throws SQLException`

- Operation: The cursor update feature has not yet been implemented. If `ResultSet` concurrency is `ResultSet.CONCUR_READ_ONLY`, it throws `SQLException`. If it is `ResultSet.CONCUR_UPDATABLE`, it throws `SQLFeatureNotSupportedException`.
- Exception: If it is already closed, it throws `SQLException`. Otherwise, refer to the operation.

## updateRow

`void updateRow() throws SQLException`

- Operation: The cursor update feature has not yet been implemented. If `ResultSet` concurrency is `ResultSet`

ItSet.CONCUR\_READ\_ONLY, it throws SQLException. If it is ResultSet.CONCUR\_UPDATABLE, it throws SQLFeatureNotSupportedException.

- Exception: If it is already closed, it throws SQLException. Otherwise, refer to the operation.

## updateRowId

`void updateRowId(int columnIndex, RowId x) throws SQLException`

- Operation: The cursor update feature has not yet been implemented. If ResultSet concurrency is ResultSet.CONCUR\_READ\_ONLY, it throws SQLException. If it is ResultSet.CONCUR\_UPDATABLE, it throws SQLFeatureNotSupportedException.
- Exception: If it is already closed, it throws SQLException. Otherwise, refer to the operation.

`void updateRowId(String columnLabel, RowId x) throws SQLException`

- Operation: The cursor update feature has not yet been implemented. If ResultSet concurrency is ResultSet.CONCUR\_READ\_ONLY, it throws SQLException. If it is ResultSet.CONCUR\_UPDATABLE, it throws SQLFeatureNotSupportedException.
- Exception: If it is already closed, it throws SQLException. Otherwise, refer to the operation.

## updateShort

`void updateShort(int columnIndex, short x) throws SQLException`

- Operation: The cursor update feature has not yet been implemented. If ResultSet concurrency is ResultSet.CONCUR\_READ\_ONLY, it throws SQLException. If it is ResultSet.CONCUR\_UPDATABLE, it throws SQLFeatureNotSupportedException.
- Exception: If it is already closed, it throws SQLException. Otherwise, refer to the operation.

`void updateShort(String columnLabel, short x) throws SQLException`

- Operation: The cursor update feature has not yet been implemented. If ResultSet concurrency is ResultSet.CONCUR\_READ\_ONLY, it throws SQLException. If it is ResultSet.CONCUR\_UPDATABLE, it throws SQLFeatureNotSupportedException.
- Exception: If it is already closed, it throws SQLException. Otherwise, refer to the operation.

## updateSQLXML

`void updateSQLXML(int columnIndex, SQLXML xmlObject) throws SQLException`

- Operation: The cursor update feature has not yet been implemented. If ResultSet concurrency is ResultSet.CONCUR\_READ\_ONLY, it throws SQLException. If it is ResultSet.CONCUR\_UPDATABLE, it throws SQLFeatureNotSupportedException.

ws `SQLFeatureNotSupportedException`.

- Exception: If it is already closed, it throws `SQLException`. Otherwise, refer to the operation.

`void updateSQLXML(String columnLabel, SQLXML xmlObject) throws SQLException`

- Operation: The cursor update feature has not yet been implemented. If `ResultSet` concurrency is `ResultSet.CONCUR_READ_ONLY`, it throws `SQLException`. If it is `ResultSet.CONCUR_UPDATABLE`, it throws `SQLFeatureNotSupportedException`.
- Exception: If it is already closed, it throws `SQLException`. Otherwise, refer to the operation.

## updateString

`void updateString(int columnIndex, String x) throws SQLException`

- Operation: The cursor update feature has not yet been implemented. If `ResultSet` concurrency is `ResultSet.CONCUR_READ_ONLY`, it throws `SQLException`. If it is `ResultSet.CONCUR_UPDATABLE`, it throws `SQLFeatureNotSupportedException`.
- Exception: If it is already closed, it throws `SQLException`. Otherwise, refer to the operation.

`void updateString(String columnLabel, String x) throws SQLException`

- Operation: The cursor update feature has not yet been implemented. If `ResultSet` concurrency is `ResultSet.CONCUR_READ_ONLY`, it throws `SQLException`. If it is `ResultSet.CONCUR_UPDATABLE`, it throws `SQLFeatureNotSupportedException`.
- Exception: If it is already closed, it throws `SQLException`. Otherwise, refer to the operation.

## updateTime

`void updateTime(int columnIndex, Time x) throws SQLException`

- Operation: The cursor update feature has not yet been implemented. If `ResultSet` concurrency is `ResultSet.CONCUR_READ_ONLY`, it throws `SQLException`. If it is `ResultSet.CONCUR_UPDATABLE`, it throws `SQLFeatureNotSupportedException`.
- Exception: If it is already closed, it throws `SQLException`. Otherwise, refer to the operation.

`void updateTime(String columnLabel, Time x) throws SQLException`

- Operation: The cursor update feature has not yet been implemented. If `ResultSet` concurrency is `ResultSet.CONCUR_READ_ONLY`, it throws `SQLException`. If it is `ResultSet.CONCUR_UPDATABLE`, it throws `SQLFeatureNotSupportedException`.
- Exception: If it is already closed, it throws `SQLException`. Otherwise, refer to the operation.

## updateTimestamp

`void updateTimestamp(int columnIndex, Timestamp x) throws SQLException`

- Operation: The cursor update feature has not yet been implemented. If `ResultSet` concurrency is `ResultSet.CONCUR_READ_ONLY`, it throws `SQLException`. If it is `ResultSet.CONCUR_UPDATABLE`, it throws `SQLFeatureNotSupportedException`.
- Exception: If it is already closed, it throws `SQLException`. Otherwise, refer to the operation.

`void updateTimestamp(String columnLabel, Timestamp x) throws SQLException`

- Operation: The cursor update feature has not yet been implemented. If `ResultSet` concurrency is `ResultSet.CONCUR_READ_ONLY`, it throws `SQLException`. If it is `ResultSet.CONCUR_UPDATABLE`, it throws `SQLFeatureNotSupportedException`.
- Exception: If it is already closed, it throws `SQLException`. Otherwise, refer to the operation.

## wasNull

`boolean wasNull() throws SQLException`

- Operation: It queries whether the column value which was read last is `NULL`. If it is `NULL`, it returns `true`. Otherwise, it returns `false`.
- Exception: If `ResultSet` is already closed or the column value never has been read, it throws `SQLException`.

## isWrapperFor

`boolean isWrapperFor(Class<?> iface)`

- Operation: It queries whether this object is the class which implemented the `iface` interface. If it so, it returns `true`. Otherwise, it returns `false`. It does not determine the presence of the wrapper and it queries only whether the given argument class type is implemented because `GOLDILOCKS` `ResultSet` object is not the wrapper of any other class.
- Exception: It does not occur.

## unwrap

`<T> T unwrap(Class<T> iface)`

- Operation: It eventually returns itself even when it is unwrapped because `GOLDILOCKS` `ResultSet` is not the wrapper of any other class. It returns after casting to that type. If `iface` is an argument of `isWrapperFor`

ppperFor() method and false is returned, then the method throws an exception.

- Exception: If iface is not this object type (when this object type is not implemented.), it throws SQLException.

## ResultSetMetaData

### getCatalogName

String getCatalogName(int column) throws SQLException

- Operation: It returns the catalog name of the column.
- Exception: If the column value is wrong, it throws SQLException.

### getColumnClassName

String getColumnClassName(int column) throws SQLException

- Operation: It returns the name of Java class which is the most appropriate to the column type. It is specified such as java.math.BigDecimal, and it refers to getName() method in Java. For binary type, it refers to byte[].class.getName(), so it can be specified such as '[B'.
- Exception: If the column value is wrong, it throws SQLException.

### getColumnCount

int getColumnCount() throws SQLException

- Operation: It returns the number of columns that the ResultSet has.
- Exception: It does not occur.

### getColumnDisplaySize

int getColumnDisplaySize(int column) throws SQLException

- Operation: It returns the maximum width when the column value is displayed.
- Exception: If the column value is wrong, it throws SQLException.

### getColumnLabel

String getColumnLabel(int column) throws SQLException

- Operation: It gets the label of the column. For example, the label is "C1 + 1" and the name is "" for the query statement such as "select C1 + 1 from t1".
- Exception: If the column value is wrong, it throws SQLException.



## getColumnName

String getColumnName(int column) throws SQLException

- Operation: It returns the alias name of the column. The original column name, not the alias name is defined to be returned in JDBC specification. However, it is recommended to use the alias name because some view names are meaningless or complicated. For example, both the name and label are "C2" for the query statement such as "select C1 as C2 from t1". For more information about the case of when name and label are different, refer to **getColumnLabel**.
- Exception: If the column value is wrong, it throws SQLException.

## getColumnType

int getColumnType(int column) throws SQLException

- Operation: It returns the type of the column. The return value is defined in types. Types.OTHERS is returned for GOLDILOCKS interval family types. The constant values of the corresponding types are returned for the other types.
- Exception: If the column value is wrong, it throws SQLException.

## getColumnTypeName

String getColumnTypeName(int column) throws SQLException

- Operation: It returns GOLDILOCKS column type name of the column.
- Exception: If the column value is wrong, it throws SQLException.

## getPrecision

int getPrecision(int column) throws SQLException

- Operation: It returns the precision of the column. It returns 0 for the type without any precision.
- Exception: If the column value is wrong, it throws SQLException.

## getScale

int getScale(int column) throws SQLException

- Operation: It returns the scale of the column. It returns 0 for the type without any scale.
- Exception: If the column value is wrong, it throws SQLException.

## getSchemaName

String getSchemaName(int column) throws SQLException

- Operation: It returns the schema name of the column.
- Exception: If the column value is wrong, it throws SQLException.

## getTableName

String getTableName(int column) throws SQLException

- Operation: It returns the table name of the column.
- Exception: If the column value is wrong, it throws SQLException.

## isAutoIncrement

boolean isAutoIncrement(int column) throws SQLException

- Operation: It returns whether it is the column which is automatically given the unique value. If so, it returns true. Otherwise, it returns false.
- Exception: If the column value is wrong, it throws SQLException.

## isCaseSensitive

boolean isCaseSensitive(int column) throws SQLException

- Operation: It returns whether the column is case sensitive. If it is case sensitive, it returns true. Otherwise, it returns false.
- Exception: If the column value is wrong, it throws SQLException.

## isCurrency

boolean isCurrency(int column) throws SQLException

- Operation: It always returns false because the currency of the column can not be determined by the server.
- Exception: If the column value is wrong, it throws SQLException.

## isDefinitelyWritable

`boolean isDefinitelyWritable(int column) throws SQLException`

- Operation: It returns whether the column is updatable. GOLDILOCKS does not support the definitely writable. It always returns the value as same as `isUpdatable()`.
- Exception: If the column value is wrong, it throws `SQLException`.

## isNullable

`int isNullable(int column) throws SQLException`

- Operation: It returns whether the column has nullable. It returns either `columnNullable` or `columnNoNulls`.
- Exception: If the column value is wrong, it throws `SQLException`.

## isReadOnly

`boolean isReadOnly(int column) throws SQLException`

- Operation: It returns whether the column is read only. It always returns the opposite value of `isUpdatable()`.
- Exception: If the column value is wrong, it throws `SQLException`.

## isSearchable

`boolean isSearchable(int column) throws SQLException`

- Operation: It returns whether the column can be used in the conditional clause. It always returns true because all target columns in GOLDILOCKS can be used in the conditional clause.
- Exception: If the column value is wrong, it throws `SQLException`.

## isSigned

`boolean isSigned(int column) throws SQLException`

- Operation: It returns whether the column has a sign. If it has a sign, it returns true. Otherwise, it returns false.
- Exception: If the column value is wrong, it throws `SQLException`.

## isWritable

`boolean isWritable(int column) throws SQLException`

- Operation: It returns whether the column is updatable.
- Exception: If the column value is wrong, it throws SQLException.

## isWrapperFor

`boolean isWrapperFor(Class<?> iface)`

- Operation: It queries whether the object is a class implementing the `iface` interface. If so, it returns `true`. Otherwise, it returns `false`. It does not determine the presence of the wrapper and it queries only whether the given argument class type is implemented because `GOLDILOCKS ResultSetMetaData` object is not the wrapper of any other class.
- Exception: It does not occur.

## unwrap

`<T> T unwrap(Class<T> iface)`

- Operation: It eventually returns itself, even when it is unwrapped because `GOLDILOCKS ResultSetMetaData` is not the wrapper of any other class. It returns after casting to that type. If `iface` is an argument of `isWrapperFor()` method and `false` is returned, the method throws an exception.
- Exception: If `iface` is not the type of the object (if this object returns the unimplemented type), it throws SQLException.

# RowId

## equals

`boolean equals(Object obj)` throws `SQLException`

- Operation: If RowId of this object is as same as RowId of obj, it returns true. Otherwise, it returns false.
- Exception: It does not occur.

## getBytes

`byte[] getBytes()` throws `SQLException`

- Operation: It returns the byte array value of RowId.
- Exception: It does not occur.

## hashCode

`int hashCode()` throws `SQLException`

- Operation: It returns the hash code value.
- Exception: It does not occur.

## toString

`String toString()` throws `SQLException`

- Operation: It returns a base-64 string of RowId value.
- Exception: It does not occur.

## RowSet

The class is not implemented

### addRowSetListener

void addRowSetListener(RowSetListener listener) throws SQLException

### clearParameters

void clearParameters() throws SQLException

### execute

void execute() throws SQLException

### getCommand

String getCommand() throws SQLException

### getDataSourceName

String getDataSourceName() throws SQLException

### getEscapeProcessing

boolean getEscapeProcessing() throws SQLException

### getMaxFieldSize

int getMaxFieldSize() throws SQLException

## getMaxRows

`int getMaxRows()` throws `SQLException`

## getPassword

`String getPassword()` throws `SQLException`

## getQueryTimeout

`int getQueryTimeout()` throws `SQLException`

## getTransactionIsolation

`int getTransactionIsolation()` throws `SQLException`

## getTypeMap

`Map<String,Class<?>> getTypeMap()` throws `SQLException`

## getUrl

`String getUrl()` throws `SQLException`

## getUsername

`String getUsername()` throws `SQLException`

## isReadOnly

`boolean isReadOnly()` throws `SQLException`

## removeRowSetListener

`void removeRowSetListener(RowSetListener listener) throws SQLException`

## setArray

`void setArray(int i, Array x) throws SQLException`

## setAsciiStream

`void setAsciiStream(int parameterIndex, InputStream x) throws SQLException`

`void setAsciiStream(int parameterIndex, InputStream x, int length) throws SQLException`

`void setAsciiStream(String parameterName, InputStream x) throws SQLException`

`void setAsciiStream(String parameterName, InputStream x, int length) throws SQLException`

## setBigDecimal

`void setBigDecimal(int parameterIndex, BigDecimal x) throws SQLException`

`void setBigDecimal(String parameterName, BigDecimal x) throws SQLException`

## setBinaryStream

`void setBinaryStream(int parameterIndex, InputStream x) throws SQLException`

`void setBinaryStream(int parameterIndex, InputStream x, int length) throws SQLException`

`void setBinaryStream(String parameterName, InputStream x) throws SQLException`

`void setBinaryStream(String parameterName, InputStream x, int length) throws SQLException`

## setBlob

`void setBlob(int i, Blob x) throws SQLException`



`void setBlob(int parameterIndex, InputStream inputStream) throws SQLException`

`void setBlob(int parameterIndex, InputStream inputStream, long length) throws SQLException`

`void setBlob(String parameterName, Blob x) throws SQLException`

`void setBlob(String parameterName, InputStream inputStream) throws SQLException`

`void setBlob(String parameterName, InputStream inputStream, long length) throws SQLException`

## setBoolean

`void setBoolean(int parameterIndex, boolean x) throws SQLException`

`void setBoolean(String parameterName, boolean x) throws SQLException`

## setByte

`void setByte(int parameterIndex, byte x) throws SQLException`

`void setByte(String parameterName, byte x) throws SQLException`

## setBytes

`void setBytes(int parameterIndex, byte[] x) throws SQLException`

`void setBytes(String parameterName, byte[] x) throws SQLException`

## setCharacterStream

`void setCharacterStream(int parameterIndex, Reader reader) throws SQLException`

`void setCharacterStream(int parameterIndex, Reader reader, int length) throws SQLException`

`void setCharacterStream(String parameterName, Reader reader) throws SQLException`

`void setCharacterStream(String parameterName, Reader reader, int length) throws SQLException`

## setClob

- | `void setClob(int i, Clob x) throws SQLException`
- | `void setClob(int parameterIndex, Reader reader) throws SQLException`
- | `void setClob(int parameterIndex, Reader reader, long length) throws SQLException`
- | `void setClob(String parameterName, Clob x) throws SQLException`
- | `void setClob(String parameterName, Reader reader) throws SQLException`
- | `void setClob(String parameterName, Reader reader, long length) throws SQLException`

## setCommand

- | `void setCommand(String cmd) throws SQLException`

## setConcurrency

- | `void setConcurrency(int concurrency) throws SQLException`

## setDataSourceName

- | `void setDataSourceName(String name) throws SQLException`

## setDate

- | `void setDate(int parameterIndex, Date x) throws SQLException`
- | `void setDate(int parameterIndex, Date x, Calendar cal) throws SQLException`
- | `void setDate(String parameterName, Date x) throws SQLException`
- | `void setDate(String parameterName, Date x, Calendar cal) throws SQLException`

## setDouble

`void setDouble(int parameterIndex, double x) throws SQLException`

`void setDouble(String parameterName, double x) throws SQLException`

## setEscapeProcessing

`void setEscapeProcessing(boolean enable) throws SQLException`

## setFloat

`void setFloat(int parameterIndex, float x) throws SQLException`

`void setFloat(String parameterName, float x) throws SQLException`

## setInt

`void setInt(int parameterIndex, int x) throws SQLException`

`void setInt(String parameterName, int x) throws SQLException`

## setLong

`void setLong(int parameterIndex, long x) throws SQLException`

`void setLong(String parameterName, long x) throws SQLException`

## setMaxFieldSize

`void setMaxFieldSize(int max) throws SQLException`

## setMaxRows

`void setMaxRows(int max) throws SQLException`

## setNCharacterStream

- | `void setNCharacterStream(int parameterIndex, Reader value) throws SQLException`
- | `void setNCharacterStream(int parameterIndex, Reader value, long length) throws SQLException`
- | `void setNCharacterStream(String parameterName, Reader value) throws SQLException`
- | `void setNCharacterStream(String parameterName, Reader value, long length) throws SQLException`

## setNClob

- | `void setNClob(int parameterIndex, NClob value) throws SQLException`
- | `void setNClob(int parameterIndex, Reader reader) throws SQLException`
- | `void setNClob(int parameterIndex, Reader reader, long length) throws SQLException`
- | `void setNClob(String parameterName, NClob value) throws SQLException`
- | `void setNClob(String parameterName, Reader reader) throws SQLException`
- | `void setNClob(String parameterName, Reader reader, long length) throws SQLException`

## setNString

- | `void setNString(int parameterIndex, String value) throws SQLException`
- | `void setNString(String parameterName, String value) throws SQLException`

## setNull

- | `void setNull(int parameterIndex, int sqlType) throws SQLException`
- | `void setNull(int paramIndex, int sqlType, String typeName) throws SQLException`
- | `void setNull(String parameterName, int sqlType) throws SQLException`

`void setNull(String parameterName, int sqlType, String typeName) throws SQLException`

## setObject

`void setObject(int parameterIndex, Object x) throws SQLException`

`void setObject(int parameterIndex, Object x, int targetSqlType) throws SQLException`

`void setObject(int parameterIndex, Object x, int targetSqlType, int scaleOrLength) throws SQLException`

`void setObject(String parameterName, Object x) throws SQLException`

`void setObject(String parameterName, Object x, int targetSqlType) throws SQLException`

`void setObject(String parameterName, Object x, int targetSqlType, int scale) throws SQLException`

## setPassword

`void setPassword(String password) throws SQLException`

## setQueryTimeout

`void setQueryTimeout(int seconds) throws SQLException`

## setReadOnly

`void setReadOnly(boolean value) throws SQLException`

## setRef

`void setRef(int i, Ref x) throws SQLException`

## setRowId

| void setRowId(int parameterIndex, RowId x) throws SQLException

| void setRowId(String parameterName, RowId x) throws SQLException

## setShort

| void setShort(int parameterIndex, short x) throws SQLException

| void setShort(String parameterName, short x) throws SQLException

## setSQLXML

| void setSQLXML(int parameterIndex, SQLXML xmlObject) throws SQLException

| void setSQLXML(String parameterName, SQLXML xmlObject) throws SQLException

## setString

| void setString(int parameterIndex, String x) throws SQLException

| void setString(String parameterName, String x) throws SQLException

## setTime

| void setTime(int parameterIndex, Time x) throws SQLException

| void setTime(int parameterIndex, Time x, Calendar cal) throws SQLException

| void setTime(String parameterName, Time x) throws SQLException

| void setTime(String parameterName, Time x, Calendar cal) throws SQLException

## setTimestamp

`void setTimestamp(int parameterIndex, Timestamp x) throws SQLException`

`void setTimestamp(int parameterIndex, Timestamp x, Calendar cal) throws SQLException`

`void setTimestamp(String parameterName, Timestamp x) throws SQLException`

`void setTimestamp(String parameterName, Timestamp x, Calendar cal) throws SQLException`

## setTransactionIsolation

`void setTransactionIsolation(int level) throws SQLException`

## setType

`void setType(int type) throws SQLException`

## setTypeMap

`void setTypeMap(Map<String,Class<?>> map) throws SQLException`

## setURL

`void setURL(int parameterIndex, URL x) throws SQLException`

## setUrl

`void setUrl(String url) throws SQLException`

## setUsername

`void setUsername(String name) throws SQLException`

## RowSetMetaData

The class is not implemented

### setAutoIncrement

| void setAutoIncrement(int columnIndex, boolean property) throws SQLException

### setCaseSensitive

| void setCaseSensitive(int columnIndex, boolean property) throws SQLException

### setCatalogName

| void setCatalogName(int columnIndex, String catalogName) throws SQLException

### setColumnCount

| void setColumnCount(int columnCount) throws SQLException

### setColumnDisplaySize

| void setColumnDisplaySize(int columnIndex, int size) throws SQLException

### setColumnLabel

| void setColumnLabel(int columnIndex, String label) throws SQLException

### setColumnName

| void setColumnName(int columnIndex, String columnName) throws SQLException



## setColumnType

`void setColumnType(int columnIndex, int SQLType) throws SQLException`

## setColumnName

`void setColumnName(int columnIndex, String typeName) throws SQLException`

## setCurrency

`void setCurrency(int columnIndex, boolean property) throws SQLException`

## setNullable

`void setNullable(int columnIndex, int property) throws SQLException`

## setPrecision

`void setPrecision(int columnIndex, int precision) throws SQLException`

## setScale

`void setScale(int columnIndex, int scale) throws SQLException`

## setSchemaName

`void setSchemaName(int columnIndex, String schemaName) throws SQLException`

## setSearchable

`void setSearchable(int columnIndex, boolean property) throws SQLException`

## setSigned

| void setSigned(int columnIndex, boolean property) throws SQLException

## setTableName

| void setTableName(int columnIndex, String tableName) throws SQLException

# Savepoint

## getSavepointId

`int getSavepointId()` throws `SQLException`

- Operation: It returns the id value which is automatically assigned.
- Exception: It throws `SQLException` because it does not have an ID if the savepoint object is created by giving its name.

## getSavepointName

`String getSavepointName()` throws `SQLException`

- Operation: It returns the name specified at the time of when a savepoint object is created.
- Exception: If the savepoint created with an automatic id value, it throws `SQLException`.

## SQLData

The class is not implemented.

### getSQLTypeName

| String getSQLTypeName() throws SQLException

### readSQL

| void readSQL(SQLInput stream, String typeName) throws SQLException

### writeSQL

| void writeSQL(SQLOutput stream) throws SQLException

# SQLXML

The class is not implemented.

## free

`void free() throws SQLException`

## getBinaryStream

`InputStream getBinaryStream() throws SQLException`

## getCharacterStream

`Reader getCharacterStream() throws SQLException`

## getSource

`<T extends Source> T getSource(Class<T> sourceClass) throws SQLException`

## getString

`String getString() throws SQLException`

## setBinaryStream

`OutputStream setBinaryStream() throws SQLException`

## setCharacterStream

`Writer setCharacterStream() throws SQLException`

## setResult

| `<T extends Result> T setResult(Class<T> resultClass) throws SQLException`

## setString

| `void setString(String value) throws SQLException`

# Statement

## addBatch

`void addBatch(String sql) throws SQLException`

- Operation: The SQL statement is added to the batch job.
- Exception: It does not occur.

## cancel

`void cancel() throws SQLException`

- Operation: It is not supported.
- Exception: It always throws `SQLFeatureNotSupportedException`.

## clearBatch

`void clearBatch() throws SQLException`

- Operation: It clears all registered batch jobs. If registered batch job does not exist, any operation is not performed.
- Exception: It does not occur.

## clearWarnings

`void clearWarnings() throws SQLException`

- Operation: It clears all `SQLWarning` objects which is owned by the statement object.
- Exception: It does not occur.

## close

`void close() throws SQLException`

- Operation: The current statement object is closed, and it is released if the statement related information assigned to the server exists. If the `ResultSet` created by the object exists, it is closed. The object is removed from the connection object which created the statement object.
- Exception: If an error occurs when statement information is released from the server, it throws an exc

ption.

## execute

`boolean execute(String sql) throws SQLException`

- Operation: It executes the SQL statement. If the executed SQL statement has the `ResultSet`, it returns `true`. Otherwise, it returns `false`.
- Exception: If the statement is already closed or the batch job is registered or an error occurs when executing from the server, it throws an exception.

`boolean execute(String sql, int autoGeneratedKeys) throws SQLException`

- Operation: It executes the SQL statement. If the executed SQL statement has the `ResultSet`, it returns `true`. Otherwise, it returns `false`. Auto key generation is not supported.
- Exception: If the statement is already closed or the batch job is registered or an error occurs when executing from the server, it throws an exception. If `autoGeneratedKeys` is not `Statement.NO_GENERATED_KEYS`, it throws `SQLFeatureNotSupportedException`.

`boolean execute(String sql, int[] columnIndexes) throws SQLException`

- Operation: It executes the SQL statement. If the executed SQL statement has the `ResultSet`, it returns `true`. Otherwise, it returns `false`. Auto key generation is not supported.
- Exception: If the statement is already closed or the batch job is registered or an error occurs when executing from the server, it throws an exception. If the `columnIndexes` are not null, it throws `SQLFeatureNotSupportedException`.

`boolean execute(String sql, String[] columnNames) throws SQLException`

- Operation: It executes the SQL statement. If the executed SQL statement has the `ResultSet`, it returns `true`. Otherwise, it returns `false`. Auto key generation is not supported.
- Exception: If the statement is already closed or the batch job is registered or an error occurs when executing from the server, it throws an exception. If the `columnNames` are not null, it throws `SQLFeatureNotSupportedException`.

## executeBatch

`int[] executeBatch() throws SQLException`

- Operation: It executes the registered batch job in turn. The communication with the server occurs per each batch job. It returns the array of the number of rows in which the update reflected after executing each batch job.
- Exception: If the statement is already closed or any batch job is not registered or an error occurs when



n executing from the server, it throws an exception.



It does not have definite advantage over the normal `execute()` because the batch jobs are not transmitted and executed at once. Use a batch execution of the `PreparedStatement` for fast processing.

## executeQuery

`ResultSet executeQuery(String sql)` throws `SQLException`

- Operation: It executes the given SQL statement and gets part of results and creates the `ResultSet`.
- Exception: If the statement is already closed or the batch job is registered or an error occurs when executing on the server or the SQL statement is not the select statement, it throws an exception.



Its operation is a bit different from `execute()`. The communicate with the server occurs twice if `getResultSet()` is performed for the same SQL statement after performing `execute()`. The execution command is performed when performing `execute()`, and the fetch related command is performed when performing `getResultSet()`. On the other hand, `executeQuery()` assumes that the SQL statement is the select statement, and it executes all with a single communication until fetch.

## executeUpdate

`int executeUpdate(String sql)` throws `SQLException`

- Operation: It executes the SQL statement. It returns the number of rows updated by the execution.
- Exception: If the statement is already closed or the batch job is registered or an error occurs when executing on the server or the SQL statement is the select statement, it throws an exception.

`int executeUpdate(String sql, int autoGeneratedKeys)` throws `SQLException`

- Operation: It executes the SQL statement. It returns the number of rows updated by the execution. The auto key generation feature is not supported.
- Exception: If the statement is already closed or the batch job is registered or an error occurs when executing on the server or the SQL statement is the select statement, it throws an exception. If `autoGeneratedKeys` is not `Statement.NO_GENERATED_KEYS`, it throws `SQLFeatureNotSupportedException`

`int executeUpdate(String sql, int[] columnIndexes)` throws `SQLException`

- Operation: It executes the SQL statement. It returns the number of rows updated by the execution. T

he auto key generation feature is not supported.

- Exception: If the statement is already closed or the batch job is registered or an error occurs when executing on the server or the SQL statement is the select statement, it throws an exception. If the columnIndexes are not null, it throws `SQLFeatureNotSupportedException`.

`int executeUpdate(String sql, String[] columnNames)` throws `SQLException`

- Operation: It executes the SQL statement. It returns the number of rows updated by the execution. The auto key generation feature is not supported.
- Exception: If the statement is already closed or the batch job is registered or an error occurs when executing from the server or the SQL statement is the select statement, it throws an exception. If the columnNames are not null, it throws `SQLFeatureNotSupportedException`.

## getConnection

`Connection getConnection()` throws `SQLException`

- Operation: It returns the connection object which created the object. If statement object is created with logical connection via the `PooledConnection`, the user gets the logical connection, not the physical connection via the method.
- Exception: If the statement is already closed, it throws an exception.

## getExplainPlan

`String getExplainPlan()` throws `SQLException`

- Operation: It is non-standard method, and it is the unique method of `GoldilocksStatement`. It gets the generated plan text. It should set for generating the plan text via `setExplainPlanOption` to use the method. For more information about the detailed usage, refer to **Viewing Plan Text**.
- Exception: If the statement is already closed or an error occurs on the server, it throws an exception.

## getExplainPlanOption

`int getExplainPlanOption()` throws `SQLException`

- Operation: It is non-standard method, and it is the unique method of `GoldilocksStatement`. It gets the option for the generating the plan text which is currently set. The return value is one of the following and the default value is `GoldilocksStatement.EXPLAIN_PLAN_OPTION_OFF`.
  - `GoldilocksStatement.EXPLAIN_PLAN_OPTION_OFF`
  - `GoldilocksStatement.EXPLAIN_PLAN_OPTION_ON`
  - `GoldilocksStatement.EXPLAIN_PLAN_OPTION_ON_VERBOSE`

- `GoldilocksStatement.EXPLAIN_PLAN_OPTION_ONLY`
- Exception: It does not occur.

## getFetchDirection

`int getFetchDirection()` throws `SQLException`

- Operation: It always returns `ResultSet.FETCH_FORWARD`.
- Exception: If the statement is already closed, it throws an exception.

## getFetchSize

`int getFetchSize()` throws `SQLException`

- Operation: It returns the default fetch size of `ResultSet` which is got from the statement object. The default value is 0, and 0 refers that the server determines the number of fetched rows. For more information, refer to `getFetchSize` of `ResultSet`.
- Exception: If the statement is already closed, it throws an exception.

## getGeneratedKeys

`ResultSet getGeneratedKeys()` throws `SQLException`

- Operation: It is not supported.
- Exception: It always throws `SQLFeatureNotSupportedException`.

## getMaxFieldSize

`int getMaxFieldSize()` throws `SQLException`

- Operation: It returns the max field size. The value limits the maximum length of the column. If the column value is bigger than this length when fetching, the rest of the data is truncated. The default value is 0, and 0 refers that the maximum length is infinite.
- Exception: If the statement is already closed, it throws an exception.

## getMaxRows

`int getMaxRows()` throws `SQLException`

- Operation: It returns the max rows. The max rows refer to the maximum number of rows of `ResultSet`

t which is got from the statement. The rows more than the maximum number of rows are ignored. The default value is 0, and 0 means infinity.

- Exception: If the statement is already closed, it throws an exception.

## getMoreResults

`boolean getMoreResults()` throws `SQLException`

- Operation: It always returns false because a user can only have a single `ResultSet` per one execution, currently. The current `ResultSet` is closed.
- Exception: If the statement is already closed, it throws an exception.

`boolean getMoreResults(int current)` throws `SQLException`

## getQueryTimeout

`int getQueryTimeout()` throws `SQLException`

- Operation: It gets the value of the query timeout. The value is the timeout value which the server applies at execution. The execution is canceled and the user gets the error related to timeout if the execution time exceeds the time. The unit is seconds and it applies the default value of the session if the user does not specifically set it. The default value of the session is 0 if it is not set with the property, and it refers to the infinite wait.
- Exception: If the statement is already closed, it throws an exception.

## getResultSet

`ResultSet getResultSet()` throws `SQLException`

- Operation: It performs the fetch for the currently execution, and it gets part of fetched results, and creates and returns the `ResultSet`. JDBC specification defines to call this method once per the execution, but it is implemented to return the same object for several calls of the method.
- Exception: If the statement is already closed, it throws an exception. If an error occurs on the server when fetching, it throws an exception.

## getResultSetConcurrency

`int getResultSetConcurrency()` throws `SQLException`

- Operation: It returns the `ResultSet` concurrency. The value determines the concurrency of `ResultSet` generated from the object. The default value is `ResultSet.CONCUR_READ_ONLY`. The updatable cursor

r is not yet supported.

- Exception: If the statement is already closed, it throws an exception.

## getResultSetHoldability

`int getResultSetHoldability()` throws `SQLException`

- Operation: It returns the `ResultSet` holdability. The value determines the holdability of `ResultSet` generated from the object. The default value is `ResultSet.HOLD_CURSORS_OVER_COMMIT`.
- Exception: If the statement is already closed, it throws an exception.

## getResultSetType

`int getResultSetType()` throws `SQLException`

- Operation: It returns the `ResultSet` type. The value determines the type of `ResultSet` generated from the object. The default value is `ResultSet.TYPE_FORWARD_ONLY`.
- Exception: If the statement is already closed, it throws an exception.

## getUpdateCount

`int getUpdateCount()` throws `SQLException`

- Operation: It returns the number of rows in which the update for the last execution is reflected. If the last executed SQL statement is not `UPDATE` statement nor is `INSERT` statement, it returns -1.
- Exception: It does not occur.

## getUpdateRowCount

`long getUpdateRowCount()` throws `SQLException`

- Operation: It is as same as `getUpdateCount`, but the returned type is `long`. It is non-standard method, and the type casting to `GoldilocksStatement` should be performed to use it.
- Exception: It does not occur.

## getWarnings

`SQLWarning getWarnings()` throws `SQLException`

- Operation: It returns `SQLWarning` accumulated on the object. If it does not exist, it returns `null`.

- Exception: It does not occur.

## isClosed

`boolean isClosed()` throws `SQLException`

- Operation: It returns whether the statement is closed. If it is closed, it returns true. Otherwise, it returns false. It can be closed not only by the explicit call of `close()` but also by the server or the connection object.
- Exception: It does not occur.

## isPoolable

`boolean isPoolable()` throws `SQLException`

- Operation: It returns whether the statement pooling is allowed for this object.
- Exception: It does not occur.

## setCursorName

`void setCursorName(String name)` throws `SQLException`

- Operation: It sets a name for the cursor created by the currently executed statement.
- Exception: If an error occurs on the server when setting the cursor name, it throws an exception.

## setEscapeProcessing

`void setEscapeProcessing(boolean enable)` throws `SQLException`

- Operation: JDBC can not ban the feature because the escape processing of the SQL statement is performed in the server parser. Any operation is not performed.
- Exception: If the statement is already closed, it throws an exception.

## setExplainPlanOption

`void setExplainPlanOption(int option)` throws `SQLException`

- Operation: It is non standard method, but it is the `GoldilocksStatement` unique method. It specifies the plan text generation options. The option should be set to one of the followings, and each meaning is as follows.

- `GoldilocksStatement.EXPLAIN_PLAN_OPTION_OFF`: The plan text is not generated.
- `GoldilocksStatement.EXPLAIN_PLAN_OPTION_ON`: The plan text is generated when executing.
- `GoldilocksStatement.EXPLAIN_PLAN_OPTION_ON_VERBOSE`: Detailed plan text is generated when executing.
- `GoldilocksStatement.EXPLAIN_PLAN_OPTION_ONLY`: The plan text is generated when executing, but the actual execution is not performed.
- Exception: When setting a value other than four values above, it throws an exception.

## setFetchDirection

`void setFetchDirection(int direction) throws SQLException`

- Operation: It sets the fetch direction. If the direction is not `ResultSet.FETCH_FORWARD`, it throws an exception because `GOLDILOCKS` supports only the forward fetch.
- Exception: If the statement is already closed or the direction is not `FETCH_FORWARD`, it throws an exception.

## setFetchSize

`void setFetchSize(int rows) throws SQLException`

- Operation: It sets the default fetch size of `ResultSet` which is got from the statement object. The default value is 0, and 0 refers that the server determines the number of fetched rows. For more information, refer to **setFetchSize** of `ResultSet`.
- Exception: If the statement is already closed, it throws an exception.

## setMaxFieldSize

`void setMaxFieldSize(int max) throws SQLException`

- Operation: It sets the max field size. The value limits the maximum length of the column. If the column value is bigger than this length when fetching, the rest of the data is truncated. The default value is 0, 0 refers that the maximum length is infinity. It is valid for `CHAR`, `VARCHAR`, `LONG VARCHAR`, `BINARY`, `VARBINARY`, `LONG VARBINARY` types.
- Exception: If the statement is already closed, it throws an exception.

## setMaxRows

`void setMaxRows(int max) throws SQLException`

- Operation: It sets the max rows. The max rows refers to the maximum number of rows of `ResultSet`

which is got from the statement. The rows more than the maximum number of rows are ignored. The default is 0, and 0 means infinity.

- Exception: If the statement is already closed, it throws an exception.

## setPoolable

`void setPoolable(boolean poolable) throws SQLException`

- Operation: It sets whether to pool the statement.
- Exception: It does not occur.

## setQueryTimeout

`void setQueryTimeout(int seconds) throws SQLException`

- Operation: It sets the value of query timeout. The value is the timeout value which the server applies at the execution, and the execution is canceled and the user gets the error related to timeout if the execution time exceeds the time. The unit is seconds and it applies the default value of the session if the user does not specifically set it. The default value of the session is 0 if it is not set with the property, and 0 refers to the infinite wait.
- Exception: If the statement is already closed, it throws an exception.

## isWrapperFor

`boolean isWrapperFor(Class<?> iface) throws SQLException`

- Operation: It queries whether the object is a class which implements the iface interface. If so, it returns true. Otherwise, it returns false. It does not determine the presence of the wrapper but it only queries only whether the given argument class type is implemented because GOLDILOCKS statement object is not the wrapper of any other class.
- Exception: It does not occur.

## unwrap

`<T> T unwrap(Class<T> iface) throws SQLException`

- Operation: It eventually returns itself, even when it is unwrapped because GOLDILOCKS statement is not the wrapper of any other class. It returns after casting to that type. If iface is an argument of isWrapperFor() method and false is returned, the method throws an exception.
- Exception: If iface is not the type of the object (when this object returns the unimplemented type), it throws SQLException.



## Struct

The class is not implemented.

### getAttributes

`Object[] getAttributes()` throws `SQLException`

### getAttributes

`Object[] getAttributes(Map<String,Class<?>> map)` throws `SQLException`

### getSQLTypeName

`String getSQLTypeName()` throws `SQLException`

## XAConnection

### getXAResource

**XAResource** `getXAResource()` throws `SQLException`

- **Operation:** It returns XAResource object which can perform XA command. When the method is called for several times, the same result is continuously returned.
- **Exception:** It does not occur.

# XADataSource

## getXAConnection

`XAConnection getXAConnection()` throws `SQLException`

- Operation: It creates `XAConnection` object and returns it. The information required for the connection should be set as the separate non-standard methods in advance.
- Exception: When connection to the server is failed, it throws `SQLException`.

`XAConnection getXAConnection(String user, String password)` throws `SQLException`

- Operation: It opens and returns a new `XAConnection` object with the username and password. Other information required for the connection should be set as the separate non-standard methods in advance.
- Exception: When connection to the server is failed, it throws `SQLException`.

## XAResource

### commit

`void commit(Xid xid, boolean onePhase) throws XAException`

- Operation: It performs the XA commit command for the global transaction xid. If onePhase is set to true, one phase commit is performed.
- Exception: If the execution result error occurs, it throws XAException.

### end

`void end(Xid xid, int flags) throws XAException`

- Operation: It performs the XA end command for the global transaction xid. The flags may be one of TMSUCCESS, TMFAIL, or TMSUSPEND.
- Exception: If the execution result error occurs, it throws XAException.

### forget

`void forget(Xid xid) throws XAException`

- Operation: It performs the XA forget command for the global transaction xid.
- Exception: If the execution result error occurs, it throws XAException.

### getTransactionTimeout

`int getTransactionTimeout() throws XAException`

- Operation: GOLDILOCKS does not support the transaction timeout. It always return 0.
- Exception: It does not occur.

### isSameRM

`boolean isSameRM(XAResource xares) throws XAException`

- Operation: It has the unique rmid when XAResource object is created. Whether it is the same XAResource object is determined with this rmid.
- Exception: It does not occur.

## prepare

`int prepare(Xid xid) throws XAException`

- Operation: It performs the XA prepare command for the global transaction xid.
- Exception: If the execution result error occurs, it throws XAException.

## recover

`Xid[] recover(int flag) throws XAException`

- Operation: It performs XA recover command with the given flag, and the array of the prepared transaction branches is returned. The flag may be one of TMSTARTRSCAN, TMENDRSCAN, TMNOFLAGS.
- Exception: If the execution result error occurs, it throws XAException.

## rollback

`void rollback(Xid xid) throws XAException`

- Operation: It performs the XA rollback command for the global transaction xid.
- Exception: If the execution result error occurs, it throws XAException.

## setTransactionTimeout

`boolean setTransactionTimeout(int seconds) throws XAException`

- Operation: GOLDDILOCKS does not support the transaction timeout. Any operation is not performed.
- Exception: It does not occur.

## start

`void start(Xid xid, int flags) throws XAException`

- Operation: It starts the global transaction with the given flag. The flag may be one of TMNOFLAGS, TMJOIN, TMRESUME.
- Exception: If the execution result error occurs, it throws XAException.

## GoldilocksInterval

To give value to a column of GOLDILOCKS by using a GoldilocksInterval object, refer to **Using Other Data Types**.

### createIntervalYear

```
public static GoldilocksInterval createIntervalYear(int yearPrecision, boolean sign, int year) throws SQLException
```

- Operation: It creates GoldilocksInterval object with the given year value. The yearPrecision refers to the number of digits which the year can have. The value of year should be equal to or bigger than 0. If the time is a positive number, sign is true. If it is a negative number, sign is false.
- Exception: If the given year value exceeds yearPrecision, an error occurs.

```
public static GoldilocksInterval createIntervalYear(int yearPrecision, String year) throws SQLException
```

- Operation: It creates GoldilocksInterval object with the given year value. The yearPrecision refers to the number of digits which the year can have. The value of year should be an integer equal to or bigger than 0.
- Exception: If the given year value exceeds yearPrecision, an error occurs.

### createIntervalMonth

```
public static GoldilocksInterval createIntervalMonth(int monthPrecision, boolean sign, int month) throws SQLException
```

- Operation: It creates GoldilocksInterval object with the given month value. The monthPrecision refers to the number of digits which the month can have. The value of month should be an integer equal to or bigger than 0. If the time is a positive number, sign is true. If it is a negative number, sign is false.
- Exception: If the given month value exceeds monthPrecision, an error occurs.

```
public static GoldilocksInterval createIntervalMonth(int monthPrecision, String month) throws SQLException
```

- Operation: It creates GoldilocksInterval object with the given month value. The monthPrecision refers to the number of digits which the month can have. The value of month should be an integer equal to or bigger than 0.
- Exception: If the given month value exceeds monthPrecision, an error occurs.

## createIntervalYearToMonth

```
public static GoldilocksInterval createIntervalYearToMonth(int yearPrecision, boolean sign,
int year, int month) throws SQLException
```

- Operation: It creates GoldilocksInterval object with the given year, month value. The yearPrecision refers to the number of digits which the year can have. The value of year, month should be equal to or bigger than 0. If the time is a positive number, sign is true. If it is a negative number, sign is false.
- Exception: If the given year value exceeds yearPrecision, an error occurs.

```
public static GoldilocksInterval createIntervalYearToMonth(int yearPrecision, String
yearToMonth) throws SQLException
```

- Operation: It creates GoldilocksInterval object with the given yearToMonth value. The yearPrecision refers to the number of digits which the year can have. yearToMonth should satisfy "yy-mm" pattern.
- Exception: If the given year value exceeds yearPrecision, an error occurs.

## createIntervalDay

```
public static GoldilocksInterval createIntervalDay(int dayPrecision, boolean sign, int day)
throws SQLException
```

- Operation: It creates GoldilocksInterval object with the given day value. The dayPrecision refers to the number of digits which the day can have. The value of day should be equal to or bigger than 0. If the time is a positive number, sign is true. If it is a negative number, sign is false.
- Exception: If the given day value exceeds dayPrecision, an error occurs.

```
public static GoldilocksInterval createIntervalDay(int dayPrecision, String day) throws
SQLException
```

- Operation: It creates GoldilocksInterval object with the given day value. The dayPrecision refers to the number of digits which the day can have. The value of day should be an integer equal to or bigger than 0.
- Exception: If the given day value exceeds dayPrecision, an error occurs.

## createIntervalHour

```
public static GoldilocksInterval createIntervalHour(int hourPrecision, boolean sign, int hour)
throws SQLException
```

- Operation: It creates GoldilocksInterval object with the given hour value. The hourPrecision refers to the number of digits which the hour can have. The value of hour should be equal to or bigger than 0.

If the time is a positive number, sign is true. If it is a negative number, sign is false.

- Exception: If the given hour value exceeds hourPrecision, an error occurs.

```
public static GoldilocksInterval createIntervalHour(int hourPrecision, String hour) throws
SQLException
```

- Operation: It creates GoldilocksInterval object with the given hour value. The hourPrecision refers to the number of digits which the hour can have. The value of hour should be an integer equal to or bigger than 0.
- Exception: If the given hour value exceeds hourPrecision, an error occurs.

## createIntervalMinute

```
public static GoldilocksInterval createIntervalMinute(int minutePrecision, boolean sign, int
minute) throws SQLException
```

- Operation: It creates GoldilocksInterval object with the given minute value. The minutePrecision refers to the number of digits which the minute can have. The value of minute should be equal to or bigger than 0. If the time is a positive number, sign is true. If it is a negative number, sign is false.
- Exception: If the given minute value exceeds minutePrecision, an error occurs.

```
public static GoldilocksInterval createIntervalMinute(int minutePrecision, String minute)
throws SQLException
```

- Operation: It creates GoldilocksInterval object with the given minute value. The minutePrecision refers to the number of digits which the minute can have. The value of minute should be an integer equal to or bigger than 0.
- Exception: If the given minute value exceeds minutePrecision, an error occurs.

## createIntervalSecond

```
public static GoldilocksInterval createIntervalSecond(int secondPrecision, int
fractionalPrecision, boolean sign, int second, int microsecond) throws SQLException
```

- Operation: It creates GoldilocksInterval object with the given second value. The secondPrecision refers to the number of digits of second, and the fractionalPrecision refers to the number of digits of microsecond. The value of second and microsecond should be equal to or bigger than 0. If the time is a positive number, sign is true. If it is a negative number, sign is false.
- Exception: If the given second value exceeds secondPrecision or the given microSecond value exceeds fractionalPrecision, an error occurs.



```
public static GoldilocksInterval createIntervalSecond(int secondPrecision, int
fractionalPrecision, boolean sign, int day, int hour, int minute, int second, int microsecond)
throws SQLException
```

- Operation: It creates GoldilocksInterval object with the given day, hour, minute, second, microsecond value. The secondPrecision refers to the number of digits of second when day, hour, minute, second is converted to second. The fractionalPrecision refers to the number of digits of microsecond. The value of day, hour, minute, second, microsecond should be equal to or bigger than 0. If the time is a positive number, sign is true. If it is a negative number, sign is false.
- Exception: If the converted second value exceeds the secondPrecision or the microSecond value exceeds the fractionalPrecision, an error occurs.

```
public static GoldilocksInterval createIntervalSecond(int secondPrecision, int
fractionalPrecision, String second) throws SQLException
```

- Operation: It creates GoldilocksInterval object with the given second string. The secondPrecision refers to the number of digits of second. The fractionalPrecision refers to the number of digits of microsecond. The second string should be one of "dd hh:mm:ss.ffffff" or "dd hh:mm:ss", "dd hh:mm", "dd hh", "hh:mm", "ss.ffffff", "ss" patterns.
- Exception: If the converted second value exceeds the secondPrecision or the microSecond value exceeds the fractionalPrecision, an error occurs. If the string does not conform to the prescribed format, an error occurs.

## createIntervalDayToHour

```
public static GoldilocksInterval createIntervalDayToHour(int dayPrecision, boolean sign, int
day, int hour) throws SQLException
```

- Operation: It creates GoldilocksInterval object with the given day, hour value. The dayPrecision refers to the number of digits of day. The value of day, hour should be equal to or bigger than 0. If the time is a positive number, sign is true. If it is a negative number, sign is false.
- Exception: If the day value exceeds dayPrecision, an error occurs.

```
public static GoldilocksInterval createIntervalDayToHour(int dayPrecision, String dayToHour)
throws SQLException
```

- Operation: It creates GoldilocksInterval object with the given dayToHour string. The dayPrecision refers to the number of digits of day. dayToHour should satisfy "dd hh" format. Or, if its format is "dd hh:mm:ss", all should be 0 except for dd, hh.
- Exception: If the day value exceeds dayPrecision or the given string does not satisfy the format, an error occurs.

## createIntervalDayToMinute

```
public static GoldilocksInterval createIntervalDayToMinute(int dayPrecision, boolean sign, int day, int hour, int minute) throws SQLException
```

- Operation: It creates GoldilocksInterval object with the given day, hour, minute value. The dayPrecision refers to the number of digits of day. The value of day, hour, minute should be equal to or bigger than 0. If the time is a positive number, sign is true. If it is a negative number, sign is false.
- Exception: If the day value exceeds dayPrecision, an error occurs.

```
public static GoldilocksInterval createIntervalDayToMinute(int dayPrecision, String dayToMinute) throws SQLException
```

- Operation: It creates GoldilocksInterval object with the given dayToMinute string. The dayPrecision refers to the number of digits of day. dayToMinute should satisfy "dd hh:mm" format. Or, if its format is "dd hh:mm:ss", all should be 0 except for dd, hh, mm.
- Exception: If the day value exceeds dayPrecision or the given string does not satisfy the format, an error occurs.

## createIntervalDayToSecond

```
public static GoldilocksInterval createIntervalDayToSecond(int dayPrecision, int fractionalPrecision, boolean sign, int day, int hour, int minute, int second, int microsecond) throws SQLException
```

- Operation: It creates GoldilocksInterval object with the given day, hour, minute, second, microsecond value. The dayPrecision refers to the number of digits of day. The fractionalPrecision refers to the number of digits of microsecond. The value of day, hour, minute, second, microsecond should be equal to or bigger than 0. If the time is a positive number, sign is true. If it is a negative number, sign is false.
- Exception: If the day value exceeds dayPrecision or the microsecond value exceeds the fractionalPrecision, an error occurs.

```
public static GoldilocksInterval createIntervalDayToSecond(int dayPrecision, String dayToSecond) throws SQLException
```

- Operation: It creates GoldilocksInterval object with the given dayToSecond string. The dayPrecision refers to the number of digits of day. The fractionalPrecision refers to the number of digits of microsecond. dayToSecond should satisfy one of "dd hh:mm:ss.ffffff", "dd hh:mm:ss", "hh:mm:ss", "hh:mm" formats.
- Exception: If the day value or the converted day value exceeds dayPrecision or the microsecond value exceeds the fractionalPrecision or the given string does not satisfy the format, an error occurs.

## createIntervalHourToMinute

```
public static GoldilocksInterval createIntervalHourToMinute(int hourPrecision, boolean sign,
int hour, int minute) throws SQLException
```

- Operation: It creates GoldilocksInterval object with the given hour, minute value. The hourPrecision refers to the number of digits of hour. The value of hour, minute should be equal to or bigger than 0. If the time is a positive number, sign is true. If it is a negative number, sign is false.
- Exception: If the hour value exceeds hourPrecision, an error occurs.

```
public static GoldilocksInterval createIntervalHourToMinute(int hourPrecision, boolean sign,
int day, int hour, int minute) throws SQLException
```

- Operation: It creates GoldilocksInterval object with the given day, hour, minute value. The hourPrecision refers to the number of digits of hour. The value of day, hour, minute should be equal to or bigger than 0. If the time is a positive number, sign is true. If it is a negative number, sign is false.
- Exception: If the hour value or the converted hour value exceeds hourPrecision, an error occurs.

```
public static GoldilocksInterval createIntervalHourToMinute(int hourPrecision, String
hourToMinute) throws SQLException
```

- Operation: It creates GoldilocksInterval object with the given hourToMinute string. The hourPrecision refers to the number of digits of hour. hourToMinute must satisfy "hh:mm" format. The value of ss or fffffff should be 0 for other formats.
- Exception: If the hour value or the converted hour value exceeds hourPrecision, an error occurs. If the given string does not satisfy the format, an error occurs.

## createIntervalHourToSecond

```
public static GoldilocksInterval createIntervalHourToSecond(int hourPrecision, int
fractionalPrecision, boolean sign, int hour, int minute, int second, int microsecond) throws
SQLException
```

- Operation: It creates GoldilocksInterval object with the given hour, minute, second, microsecond value. The hourPrecision refers to the number of digits of hour. The fractionalPrecision refers to the number of digits of microsecond. The value of hour, minute, second, microsecond should be equal to or bigger than 0. If the time is a positive number, sign is true. If it is a negative number, sign is false.
- Exception: If the hour value exceeds hourPrecision or the microsecond value exceeds the fractionalPrecision, an error occurs.

```
public static GoldilocksInterval createIntervalHourToSecond(int hourPrecision, int
fractionalPrecision, boolean sign, int day, int hour, int minute, int second, int microsecond)
throws SQLException
```

- Operation: It creates GoldilocksInterval object with the given day, hour, minute, second, microsecond value. The hourPrecision refers to the number of digits of hour. The fractionalPrecision refers to the number of digits of microsecond. The value of day, hour, minute, second, microsecond should be equal to or bigger than 0. If the time is a positive number, sign is true. If it is a negative number, sign is false.
- Exception: If the hour value or the converted hour value exceeds hourPrecision or the microsecond value exceeds the fractionalPrecision, an error occurs.

```
public static GoldilocksInterval createIntervalHourToSecond(int hourPrecision, int fractionalPrecision, String hourToSecond) throws SQLException
```

- Operation: It creates GoldilocksInterval object with the given hourToSecond string. The hourPrecision refers to the number of digits of hour. The fractionalPrecision refers to the number of digits of microsecond. hourToSecond should satisfy "hh:mm:ss.ffffff", "hh:mm:ss", or "hh:mm" format. If dd is included, the value of converted hour should not exceed hourPrecision.
- Exception: If the hour value or the converted hour value exceeds hourPrecision or the microsecond value exceeds the fractionalPrecision, or the given string does not satisfy the format, an error occurs.

## createIntervalMinuteToSecond

```
public static GoldilocksInterval createIntervalMinuteToSecond(int minutePrecision, int fractionalPrecision, boolean sign, int minute, int second, int microsecond) throws SQLException
```

- Operation: It creates GoldilocksInterval object with the given minute, second, microsecond value. The minutePrecision refers to the number of digits of minute. The fractionalPrecision refers to the number of digits of microsecond. The value of minute, second, microsecond should be equal to or bigger than 0. If the time is a positive number, sign is true. If it is a negative number, sign is false.
- Exception: If the minute value exceeds the minutePrecision or the microsecond value exceeds the fractionalPrecision, an error occurs.

```
public static GoldilocksInterval createIntervalMinuteToSecond(int minutePrecision, int fractionalPrecision, boolean sign, int day, int hour, int minute, int second, int microsecond) throws SQLException
```

- Operation: It creates GoldilocksInterval object with the given day, hour, minute, second, microsecond value. The minutePrecision refers to the number of digits of minute. The fractionalPrecision refers to the number of digits of microsecond. The value of day, hour, minute, second, microsecond should be equal to or bigger than 0. If the time is a positive number, sign is true. If it is a negative number, sign is false.
- Exception: If the minute value or the converted minute value exceeds minutePrecision or the microsecond value exceeds the fractionalPrecision, an error occurs.

```
public static GoldilocksInterval createIntervalMinuteToSecond(int minutePrecision, int fractionalPrecision, String minuteToSecond) throws SQLException
```

- Operation: It creates GoldilocksInterval object with the given minuteToSecond string. The minutePrecision refers to the number of digits of minute. The fractionalPrecision refers to the number of digits of microsecond. minuteToSecond should satisfy "mm:ss.ffffff" or "mm:ss" format. If dd or hh is included, the value of the converted minute should not exceed minutePrecision.
- Exception: If the minute value or the converted minute value exceeds the minutePrecision or the microsecond value exceeds the fractionalPrecision or the given string does not satisfy the format, an error occurs.

## getSign

```
public int getSign()
```

- Operation: If the time is a positive number, 1 is returned. If the time is a negative number, -1 is returned.
- Exception: It does not occur.

## getYear

```
public int getYear()
```

- Operation: It returns the year value. Whether the interval object is a negative number is not returned through getYear().
- Exception: It does not occur.

## getMonth

```
public int getMonth()
```

- Operation: It returns the month value. Whether the interval object is a negative number is not returned through getMonth().
- Exception: It does not occur.

## getAccumulatedMonth

```
public int getAccumulatedMonth()
```

- Operation: It converts the value of year and month to the value of month, and returns the result.

- Exception: It does not occur.

## getDay

```
public int getDay()
```

- Operation: It returns the day value. Whether the interval object is a negative number is not returned through `getDay()`.
- Exception: It does not occur.

## getHour

```
public int getHour()
```

- Operation: It returns the hour value. Whether the interval object is a negative number is not returned through `getHour()`.
- Exception: It does not occur.

## getAccumulatedHour

```
public int getAccumulatedHour()
```

- Operation: It converts the value of day and hour to the value of hour, and returns the result.
- Exception: It does not occur.

## getMinute

```
public int getMinute()
```

- Operation: It returns the minute value. Whether the interval object is a negative number is not returned through `getMinute()`.
- Exception: It does not occur.

## getAccumulatedMinute

```
public int getAccumulatedMinute()
```

- Operation: It converts the value of day, hour and minute to the value of minute, and returns the result.
- Exception: It does not occur.

## getSecond

```
public int getSecond()
```

- Operation: It returns the second value. Whether the interval object is a negative number is not returned through `getSecond()`.
- Exception: It does not occur.

## getAccumulatedSecond

```
public int getAccumulatedSecond()
```

- Operation: It converts the value of day, hour, minute and second to the value of second, and returns the result.
- Exception: It does not occur.

## getMicroSecond

```
public int getMicroSecond()
```

- Operation: It returns the microsecond value. Whether the interval object is a negative number is not returned through `getMicroSecond()`.
- Exception: It does not occur.

## getAccumulatedMicroSecond

```
public long getAccumulatedMicroSecond()
```

- Operation: It converts the value of day, hour, minute, second and microsecond to the value of microsecond, and returns the result.
- Exception: It does not occur.

## getTypeName

```
public String getTypeName()
```

- Operation: The type name is returned.
- Exception: It does not occur.

## getSqlType

```
public int getSqlType()
```

- Operation: The type of this object is returned as the type constant defined in `GoldilocksTypes`.
- Exception: It does not occur.

## toString

```
public String toString()
```

- Operation: The interval value which is indicated by this object is returned as a string value.
- Exception: It does not occur.



# GOLDILOCKS Type

## Constant Definition

```
public static final int INTERVAL_YEAR;
public static final int INTERVAL_MONTH;
public static final int INTERVAL_DAY;
public static final int INTERVAL_HOUR;
public static final int INTERVAL_MINUTE;
public static final int INTERVAL_SECOND;
public static final int INTERVAL_YEAR_TO_MONTH;
public static final int INTERVAL_DAY_TO_HOUR;
public static final int INTERVAL_DAY_TO_MINUTE;
public static final int INTERVAL_DAY_TO_SECOND;
public static final int INTERVAL_HOUR_TO_MINUTE;
public static final int INTERVAL_HOUR_TO_SECOND;
public static final int INTERVAL_MINUTE_TO_SECOND;
public static final int TIME_WITH_TIME_ZONE;
public static final int TIMESTAMP_WITH_TIME_ZONE;
```

These constants are used as like the constants of `java.sql.Types`. In other words, they are used when specifying the types in `setObject` of `PreparedStatement` or the types in `getObject` of `ResultSet`. These types are separately provided by `GoldilocksTypes` because they are not defined in the JDBC standard.

## Type Conversion

The following tables describe how to convert types.

**Table 32-3** SQL types → GOLDILOCKS types

SQL type	GOLDILOCKS type
<code>Types.BIGINT</code>	<code>NATIVE_BIGINT</code>
<code>Types.BINARY</code>	<code>BINARY(2000)</code>
<code>Types.BIT</code>	<code>BOOLEAN</code>
<code>Types.BOOLEAN</code>	<code>BOOLEAN</code>
<code>Types.BLOB</code>	<code>LONG VARBINARY</code>
<code>Types.CHAR</code>	<code>CHAR(2000)</code>
<code>Types.CLOB</code>	<code>LONG VARCHAR</code>
<code>Types.DATE</code>	<code>DATE</code>

SQL type	GOLDILOCKS type
Types.DECIMAL	DECIMAL
Types.DOUBLE	NATIVE_DOUBLE
Types.FLOAT	FLOAT
Types.NUMERIC	NUMBER
Types.INTEGER	NATIVE_INTEGER
Types.LONGVARBINARY	LONG VARBINARY
Types.LONGVARCHAR	LONG VARCHAR
Types.REAL	NATIVE_REAL
Types.ROWID	ROWID
Types.SMALLINT	NATIVE_SMALLINT
Types.TIME	TIME
Types.TIMESTAMP	TIMESTAMP
Types.VARBINARY	VARBINARY(4000)
Types.VARCHAR	VARCHAR(4000)
GoldilocksTypes.INTERVAL_YEAR	INTERVAL YEAR
GoldilocksTypes.INTERVAL_MONTH	INTERVAL MONTH
GoldilocksTypes.INTERVAL_YEAR_TO_MONTH	INTERVAL YEAR TO MONTH
GoldilocksTypes.INTERVAL_DAY	INTERVAL DAY
GoldilocksTypes.INTERVAL_HOUR	INTERVAL HOUR
GoldilocksTypes.INTERVAL_MINUTE	INTERVAL MINUTE
GoldilocksTypes.INTERVAL_SECOND	INTERVAL SECOND
GoldilocksTypes.INTERVAL_DAY_TO_HOUR	INTERVAL DAY TO HOUR
GoldilocksTypes.INTERVAL_DAY_TO_MINUTE	INTERVAL DAY TO MINUTE
GoldilocksTypes.INTERVAL_DAY_TO_SECOND	INTERVAL DAY TO SECOND
GoldilocksTypes.INTERVAL_HOUR_TO_MINUTE	INTERVAL HOUR TO MINUTE
GoldilocksTypes.INTERVAL_HOUR_TO_SECOND	INTERVAL HOUR TO SECOND
GoldilocksTypes.INTERVAL_MINUTE_TO_SECOND	INTERVAL MINUTE TO SECOND
Types.OTHER	N/A
Types.ARRAY	N/A
Types.DATALINK	N/A
Types.DISTINCT	N/A
Types.NCHAR	N/A
Types.NCLOB	N/A
Types.NVARCHAR	N/A
Types.JAVA_OBJECT	N/A
Types.REF	N/A
Types.SQLXML	N/A
Types.STRUCT	N/A

**Table 32-4** Whether supporting getter method for GOLDILOCKS type - 1

	NATIVE_SMALLINT	NATIVE_INTEGER	NATIVE_BIGINT	NATIVE_REAL	NATIVE_DOUBLE
getByte	O	O	O	O	O
getShort	O	O	O	O	O
getInt	O	O	O	O	O
getLong	O	O	O	O	O
getFloat	O	O	O	O	O
getDouble	O	O	O	O	O
getBigDecimal	O	O	O	O	O
getBoolean	Available only for 0,1	Available only for 0,1	Available only for 0,1	Available only for 0,1	Available only for 0,1
getString	O	O	O	O	O
getBytes	raw data	raw data	raw data	raw data	raw data
getDate	X	X	X	X	X
getTime	X	X	X	X	X
getTimestamp	X	X	X	X	X
getAsciiStream	raw data	raw data	raw data	raw data	raw data
getBinaryStream	raw data	raw data	raw data	raw data	raw data
getCharacterStream	X	X	X	X	X
getClob	O	O	O	O	O
getBlob	raw data	raw data	raw data	raw data	raw data
getArray	X	X	X	X	X
getRef	X	X	X	X	X
getURL	X	X	X	X	X
getObject	Short	Integer	Long	Float	Double
getRowId	X	X	X	X	X

**Table 32-5** Whether supporting getter method for GOLDILOCKS Type - 2

	BOOLEAN	FLOAT/ NUMBER	CHAR/ VARCHAR/ LONG VARCHAR	BINARY/ VARBINARY/ LONG VARBINARY	ROWID
getByte	0 or 1	O	Available only for numeric	X	X
getShort	0 or 1	O	Available only for numeric	X	X
getInt	0 or 1	O	Available only for numeric	X	X
getLong	0 or 1	O	Available only for numeric	X	X

	BOOLEAN	FLOAT/ NUMBER	CHAR/ VARCHAR/ LONG VARCHAR	BINARY/ VARBINARY/LON G VARBINARY	ROWID
getFloat	0 or 1	O	Available only for numeric	X	X
getDouble	0 or 1	O	Available only for numeric	X	X
getBigDecimal	0 or 1	O	Available only for numeric	X	X
getBoolean	O	Available only for 0,1	Available only for "t", "f", "true", "false", "y", "n", "yes", "no", "on", "off", "1", "0" (case-insensitive)	X	X
getString	"TRUE" or "FALSE"	O	O	O	O
getBytes	raw data	raw data	raw data	O	raw data
getDate	X	X	Available only for date format	X	X
getTime	X	X	Available only for time format	X	X
getTimestamp	X	X	Available only for timestamp format	X	X
getAsciiStream	raw data	raw data	raw data	O	raw data
getBinaryStream	raw data	raw data	raw data	O	raw data
getCharacterStream	X	X	O	X	X
getClob	"TRUE" or "FALSE"	O	O	O	O
getBlob	raw data	raw data	raw data	raw data	raw data
getArray	X	X	X	X	X
getRef	X	X	X	X	X
getURL	X	X	X	X	X
getObject	Boolean	BigDecimal	String	byte[]	RowId
getRowId	X	X	X	X	O

**Table 32-6** Whether supporting getter method for GOLDILOCKS Type - 3

	DATE	TIME/ TIME WITH TIME ZONE	TIMESTAMP/ TIMESTAMP WITH TIME ZONE	INTERVAL
--	------	------------------------------	--	----------

	DATE	TIME/ TIME WITH TIME ZONE	TIMESTAMP/ TIMESTAMP WITH TIME ZONE	INTERVAL
getByte	X	X	X	Available only for a single item type
getShort	X	X	X	Available only for a single item type
getInt	X	X	X	Available only for a single item type
getLong	X	X	X	Available only for a single item type
getFloat	X	X	X	Available only for a single item type
getDouble	X	X	X	Available only for a single item type
getBigDecimal	X	X	X	Available only for a single item type
getBoolean	X	X	X	X
getString	O	O	O	O
getBytes	raw data	raw data	raw data	raw data
getDate	O	O	O	X
getTime	O	O	O	X
getTimestamp	O	O	O	X
getAsciiStream	raw data	raw data	raw data	raw data
getBinaryStream	raw data	raw data	raw data	raw data
getCharacterStream	X	X	X	X
getClob	O	O	O	O
getBlob	raw data	raw data	raw data	raw data
getArray	X	X	X	X
getRef	X	X	X	X
getURL	X	X	X	X
getObject	Date	Time	Timestamp	GoldilocksInterval
getRowId	X	X	X	X



**33.**

---

## **Embedded SQL**

## 33.1 Precompiler

### Overview

GOLDILOCKS precompiler is a programming development tool which enables a user to use embedded SQL in the high-level programming language. Currently, GOLDILOCKS supports the precompiler only for the language such as C/ C++, and it is called as gpec.

### Developing Embedded SQL Applications

As described in Figure 1 **Developing the embedded SQL applications**, the user creates a C source program including embedded SQL, and converts it via gpec precompiler. Then, the pure C code is created of which the embedded SQL on the source code is converted to the contents calling the library of GOLDILOCKS. This C code uses C compiler of the system to perform compile as object code and link it with libgoldilocksesql.a which is an embedded SQL library provided by GOLDILOCKS, then completes the final application.

Figure 1 Developing the embedded SQL applications

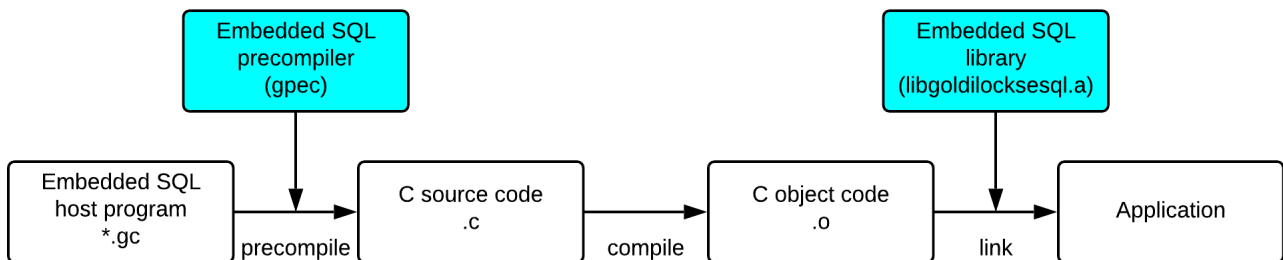

### Configuring Embedded SQL Application Development Tool

Embedded SQL application of GOLDILOCKS consists of the following elements.

Directory or File	Description
\bin\gpec	GOLDILOCKS precompiler embedded SQL for C
\include\goldilocksesql.h	It is an embedded SQL library header file. Precompiler automatically inserts it, so the user does not have to do any extra work.
\include\sqlca.h	It is the SQLCA data structure related header file.
\lib\libgoldilocksesql.a, \lib\libgoldilocksesqls.so	It is the embedded SQL run-time library.
\lib\libgoldilocks.a, \lib\libgoldilockss.so	It is the GOLDILOCKS DA/ CS mixed mode library.
\lib\libgoldilocks.a, \lib\libgoldilocksas.so	It is the GOLDILOCKS DA mode library.



Directory or File	Description
\lib\libgoldilocksc.a, \lib\libgoldilockscs.so	It is the GOLDILOCKS CS mode library.
\sample\EmbeddedSQL	It is a sample program.

## Building Application

This chapter describes the process to build an embedded SQL source program of GOLDILOCKS and make the application.

## Precompile

### Description

The user precompiles the C/ C++ source code which was written by using embedded SQL, and generates the pure C/ C++ source code. The core of this process is converting the user-created embedded SQL to the library call provided by GOLDILOCKS, and the C/ C++ source code is not modified except for embedded SQL.

### Usage

The name of GOLDILOCKS precompiler is `gpec`, and it is located in `$GOLDILOCKS_HOME/bin/`. `gpec` is used as follows.

```
$ gpec [OPTION]... <input file>
```

<input file> is input to `gpec`, and `gpec` generates the C/ C++ source code after precompile process. The extension of <input file> is `*.gc`, and it can be omitted. If <input file> does not have `*.gc` extension, the file name with the extension should be required.

For more information about options given to `gpec`, refer to **Precompiler Options**.

### Example

```
$ gpec sample1

FileName: sample1
Pre-compile sample1.gc -> sample1.c
```

## Compile

C/ C++ source code is generated after precompile process. The source code generates the object code by using the C/ C++ compiler provided in the platform. For more information about this process refer to the C/ C++ compiler manual which is provided by the user platform.

## Link

The application is generated by linking the object codes generated through the process above, and GOLD ILOCKS supports libgoldilocksesql.a for an embedded SQL. The library includes the GOLDILOCKS APIs which is converted from the embedded SQL by the precompiler, so it is prerequisite when making the embedded SQL application.

Additionally, the required library varies upon the various operation modes of GOLDILOCKS, and the required library is selected and linked according to the operation mode of the current application as follows.

Operation mode	Static library	Shared object
DA dedicated	libgoldilocks.a	libgoldilocksas.so
CS dedicated	libgoldilocksc.a	libgoldilockscs.so
DA/ CS mixed	libgoldilocks.a	libgoldilockss.so

Other link processes are as same as the process of generating the common C/ C++ application so refer to the linker manual provided by the user platform.

## Example

*make* is used a lot to easily perform the precompile, compile, link process above. The following is an example of Makefile to create the sample program. Refer to the following example to make the Makefile which is suitable for the user environment.

```
CC = gcc
CFLAGS = -g -Wall

INC = -I$(GOLDILOCKS_HOME)/include
LFLAGS = -L$(GOLDILOCKS_HOME)/lib

LIB = -lgoldilocksesql -lpthread -lm -lrt
ifeq ($(CSMODE), 1)
    LIB += -lgoldilocksc
else
    ifeq ($(MIXMODE), 1)
```

```

        LIB += -lgoldilocks
    else
        LIB += -lgoldilocksa
    endif
endif

GPEC = gpec
GPECFLAGS =
#GPECFLAGS = --unsafe-null --no-prompt
BINS = overview sample1 sample2 sample3 sample4 sample5 dyn1 dyn2 number date_time thread1
fetch_struct_array

ifneq ($(MAKECMDGOALS), clean)
ifneq ($(MAKECMDGOALS), all)
TARGET = $(MAKECMDGOALS)
OBJECT = $(TARGET).o
C_SRC = $(TARGET).c
endif
endif

```

- Implicit rules

```

.SUFFIXES: .gc .c .o
.gc.c:
    $(GPEC) $(GPECFLAGS) $^          ❶ Precompile
.c.o:
    $(CC) $(CFLAGS) -c $(INC) $^     ❷ Compile

```

- Build rules

```

NoTarget :
    @echo "Syntax : make {all | sample_name | clean}"
    @echo "sample_name is one of '$(BINS)'"

all :
    for target in $(BINS); do \
        $(MAKE) $$target; \
    done

$(OBJECT) : $(C_SRC)
$(TARGET) : $(OBJECT)
    $(CC) -o $@ $^ $(LFLAGS) $(LIB)  ❸ Link

```

```
clean :
    rm -rf $(BINS) *.o *.c *~ core
```

## Sample

GOLDILOCKS provides a simple embedded SQL sample code to help to create an embedded SQL application. The sample code is in \$GOLDILOCKS\_HOME/sample/EmbeddedSQL directory, and sample.sql which is in the same directory should be executed first to execute the samples.

```
$ cd $GOLDILOCKS/sample/EmbeddedSQL
$ gsql test test -i sample.sql
$ make
Syntax : make {all | sample_name | clean}
sample_name is one of 'overview sample1 sample2 sample3 sample4 sample5 dyn1 dyn2 number
date_time thread1 fetch_struct_array'
```

If *make all* is executed, all samples are built. Execute *make <sample\_name>* to build a particular sample alone. For <Sample\_name>, refer to the message above. If sample2 is built and executed, and the result is as follows.

```
$ make sample2
gpec sample2.gc
FileName: sample2.gc
Pre-compile sample2.gc -> sample2.c
gcc -g -Wall -c -I/home/mycomman/work/product/Gliese/home/include sample2.c
gcc -o sample2 sample2.o -L/home/mycomman/work/product/Gliese/home/lib -lgoldilocksesql
-lpthread -lm -lrt -lgoldilocksa
$ ./sample2
Connect goldilocks ...
```

EMPNO	ENAME	JOB	SALARY
2854	Park	RND	800
2098	Kim	SALESMAN	1600
2175	Choi	SALESMAN	1250
2306	Lee	SUPPORT	2975
2122	Lyu	SALESMAN	1250
2999	Ohn	SUPPORT	2850
2012	Cheon	SUPPORT	2450
2168	Sohn	RND	3000
2836	Seo	CEO	5000

```

2022          Song  SALESMAN  1500
2232          Jeong      RND    1100
2676          Kang      RND     950
2714          Cho       RND   3000
2441          Yoon      RND   1300
=====
Record Count = 14
=====
SUCCESS
#####

```

## Precompiler Options

This chapter describes the options of gpec.

### --no-prompt, -n

#### Description

It does not output the version information.

#### Example

```

$ gpec --no-prompt sample2
FileName: sample2
Pre-compile sample2.gc -> sample2.c
$

```

### --version, -v

#### Description

It outputs only the version information, then exits.

#### Example

```

$ gpec --version
$

```

## --help, -h

### Description

It outputs the help message. It performs the same operation even when an option or <input file> does not exist in gpec.

### Example

```
$ gpec --help
gpec is the GOLDILOCKS embedded SQL precompiler for C programs.

Usage:
  gpec [OPTION]... <input file>

Options:
  --no-prompt      No Print version information
  --version        Print version information and exit
  --help           Print help message
  --output         Describe output filename
  --unsafe-null    Allow a NULL fetch without indicator variable
  --include-path   Describe header file path
  --no-lineinfo    Exclude line information
  --char_map       Mapping of character arrays ( CHARZ | STRING )
  --cumulative     SQLERRD[2] records cumulative sum of rows processed for FETCH CURSOR.
  --autocommit     Set autocommit TRUE to all connection.

$
```

## --output, -o

### Description

It specifies the name of precompile result file. If this option is not given, the file name as same as <input file> is created with the extension of .c.

### Example

- When an output is not used.

```
$ gpec sample2.gc
FileName: sample2.gc
Pre-compile sample2.gc -> sample2.c
```

```
$ ls
sample2.c  sample2.gc
```

- When an output is used.

```
$ gpec --output outfile.cpp sample2.gc
FileName: sample2.gc
Pre-compile sample2.gc -> outfile.cpp
$ ls
outfile.cpp  sample2.gc
```

## --unsafe-null

### Description

Even if it does not use the host indicator variable, It succeeds when NULL fetch occurs. It means that the operation is successful, but it does not mean that the NULL value can be fetched.

### Example

```
$ gpec --unsafe-null sample2
FileName: sample2
Option : --unsafe-null
Pre-compile sample2.gc -> sample2.c
$
```

## --include-path, -I

### Description

It describes the path of the header file to refer when performing the precompile. Other header files are found by using EXEC SQL INCLUDE statement when performing the precompile. First, it searches in the directory where the current file is located. If it can not find any file, then it searches in the directories where the option is described in turn.

### Example

The following is an example of when the header file is in include directory.

- When an error occurs.

```

$ gpec sample.gc
FileName: sample.gc
Pre-compile sample.gc -> sample.c
ERR-42000(41000): syntax error
Error at line 12, in file sample.gc
ERR-42000(41004): "decl.h": file not exist
ERR-42000(41000): syntax error
rsEmpRecord gRecord[] = {
^
Error at line 15, in file sample.gc

```

- When -I option is used.

```

$ gpec -Iinclude sample.gc
FileName: sample.gc
Pre-compile sample.gc -> sample.c
$

```

## --no-lineinfo

### Description

When gc file is converted to c file by default, GPEC adds #line information to enable debugging with gc file. However, if this option is used, It does not add the line information through #line preprocessor when creating c file.

### Example

```

$ gpec --no-lineinfo sample2
FileName: sample2
Pre-compile sample2.gc -> sample2.c
$

```

## --char\_map, -c

### Description

It sets to which type the char type data declared in a DECLARE SECTION is mapped. The default value is 'STRING', and it is null-terminated data type. 'CHARZ' is space padded and null-terminated data type.



## Example

```
$ gpec --char_map=STRING overview
FileName: overview
Pre-compile overview.gc -> overview.c
$ gpec --char_map=CHARZ overview
FileName: overview
Pre-compile overview.gc -> overview.c
```

## --define, -D

### Description

It is a define name used in gpec and it is set to 1.

### Example

```
$ gpec --define=AAA preprocess
FileName: preprocess
Pre-compile preprocess.gc -> preprocess.c
$ gpec -D BBB preprocess
FileName: preprocess
Pre-compile preprocess.gc -> preprocess.c
ERR-42000(41028): 'BBB' macro is already defined at line 45, in file preprocess.gc
```

## --cumulative

### Description

It processes sqlerrd[2] in FETCH CURSOR statement as the accumulated total.

### Example

```
$ gpec --cumulative sample.gc
FileName: sample Option : --cumulative
Pre-compile sample.gc -> sample.c
$
```

## --autocommit

### Description

It sets *auto commit* of all connections to TRUE.

### Example

```
$ gpec --autocommit sample.gc  
FileName: sample Option : --autocommit  
Pre-compile sample.gc -> sample.c  
$
```

## 33.2 Embedded SQL

### Preprocessing

#### Overview

It performs the preprocessing before precompiling in gpec.

gpec supports the preprocess statements such as `#if`, `#ifdef`, `#if defined`, `#ifndef`, `#else`, `#elif`, `#endif`, `#define`, `#undef`.

It can use a predefine by using a `--define` option of gpec. It is defined as 1 when it is predefined with a `gpec` option.

e.g. `gpec --define=_DEV_ Test.gc` is as same as `#define _DEV_ (1)` in `Test.gc` file.

#### Applicable Range

The host variable of SQL precompiler feature for gpec is applied only within a declare section and the feature is used in the EXEC SQL statement. (The host variable outside of the declare section can not be used in the host EXEC SQL statement.)

gpec preprocessor are applied all over the source.

Only the header file declared with EXEC SQL INCLUDE is applied to an include file.

```
#define _DEV1_
EXEC SQL BEGIN DECLARE SECTION;
#define _DEV2_
char username[10];
char password[10];
#ifdef _DEV1_
VARCHAR conn_str[20]; ①
#elif defined _DEV2_
VARCHAR conn_str[30]; ②
#endif
EXEC SQL END DECLARE SECTION;
```



- ① `_DEV1_` is defined irrespective of the position of DECLARE SECTION, so it is processed as a host variable in gpec.
- ② `_DEV1_` is defined, so its location becomes false, so is processed as a white space in gpec.

When creating c file from the file above using gpec, conn\_str[20] is converted and #ifdef, #elif, #endif preprocessor statements and conn\_str[30] are converted into white spaces as follows.

```

/* EXEC SQL BEGIN DECLARE SECTION; */
#define _DEV2_
char username[10];
char password[10];
/* VARCHAR conn_str[20]; */
struct { int len; char arr[20]; } conn_str; ❶

                                     ❷

/* EXEC SQL END DECLARE SECTION; */

```



❶ \_DEV1\_ is defined irrespective of the position of DECLARE SECTION, so it is processed as a host variable in gpec.

❷ \_DEV1\_ is defined, so its location becomes false, so is processed as a white space in gpec.

## Types

### #if

- Syntax

```
#if constant
```

or

```
#if defined identifier
```

or

```
#if !defined identifier
```

- Example

```

#if 0
int sVar1;
#endif
#if 3-2 ❶ An operation is available.
int sVar2;

```

```
#endif
#if defined _DEV_
int sVar3;
#endif
#if !defined (_DEV_)
int sVar4;
#endif
```

## #ifdef, #ifndef

- Syntax

```
#ifdef identifier
```

or

```
#ifndef identifier
```

- Example

```
#ifdef _DEV_
int sVar1;
#endif
#ifndef _DEV_
int sVar2;
#else
int sVar3;
#endif
```

## #else, #elif, #endif

- Syntax

```
#else
```

or

```
#endif
```

or

`#elif constant`

or

`#elif defined identifier`

- Example

```
#if 1
int sVar1;
#else
int sVar2;
#endif
#if 0
int sVar3;
#elif 1
int sVar4;
#else
int sVar5;
#endif
#ifdef _DEV1_
int sVar6;
#elif defined _DEV2_
int sVar7;
#elif !defined _DEV3_
int sVar8;
#endif
```

## **#define, #undef**

- Syntax

`#define identifier`

or

`#define identifier constant`

or

`#undef identifier`

- Example

```
#define _DEV1_
EXEC SQL BEGIN DECLARE SECTION;
#define _DEV2_
char username[10];
char password[10];
#ifdef _DEV1_
VARCHAR conn_str[20]; ❶
#elif defined _DEV2_
VARCHAR conn_str[30]; ❷
#endif
#undef _DEV2_
#ifdef _DEV2_
VARCHAR sDept[10]; ❸
#endif
EXEC SQL END DECLARE SECTION;
```



- ❶ `_DEV1_` is defined, so it is processed as a host variable in gpec.
- ❷ `#ifdef _DEV1_` is true, so `_DEV2_` is processed as a white space in gpec.
- ❸ `_DEV2_` is undefined, so it is processed as a white space in gpec.



An annotation can be used in `#define`. However, if `#define` are written along multiple lines, the `n` the annotation can not be correctly processed.

```
#define _DEF1_ 1 \ ❶
+ 1
#define _DEF2_ 1 \ /* this ❷
is comment */ + 1
#define _DEF3_ 1 /* this is comment */ + 1 ❸
```



- ❶ `_DEF1_` is processed as `1 + 1`.
- ❷ `_DEF2_` is processed as `1`.
- ❸ `_DEF3_` is processed as `1 + 1`.

## Constraints

Even though it is defined within a declare section, it is not extended to an EXEC SQL statement.

```
EXEC SQL BEGIN DECLARE SECTION;
#define C_EMP_NO 14
char username[10];
EXEC SQL END DECLARE SECTION;
EXEC SQL
    SELECT USERNAME INTO :username
    FROM EMP
    WHERE EMPNO = C_EMP_NO; ❶ A wrong MACRO is used.
```

## Expansion

MACRO can be used in the middle of c statement or in the middle of EXEC SQL statement.

```
#define _DEV_
EXEC SQL BEGIN DECLARE SECTION;
char
#ifdef _DEV_
sTrue[10];
#else
sFalse[10];
#endif
EXEC SQL END DECLARE SECTION;
EXEC SQL SELECT
#ifdef _DEV_
    "true" INTO :sTrue
#else
    "false" INTO :sFalse
#endif
FROM DUAL;
```

gpec can execute the preprocessor to create the following c code. The following is an example in which the converting from SQL statement to c code is omitted.

```
#define _DEV_
EXEC SQL BEGIN DECLARE SECTION;
char
sTrue[10];
```



```
EXEC SQL END DECLARE SECTION;
EXEC SQL SELECT

        "true" INTO :sTrue

FROM DUAL;
```

## Connection

### Connecting to Database

A process of connecting to the database server is required to perform the operation by connecting to the database in the embedded SQL program.

The syntax for connecting to the database is expressed in GOLDILOCKS as follows.

```
EXEC SQL [ AT <db_name> ] CONNECT <user_name> IDENTIFIED BY <password> [ AT <db_name> ] [
USING <conn_string> ]
<db_name> := dbname | :hostvar
<user_name> := username | :hostvar
<password> := password | :hostvar
<conn_string> := connection_string | :hostvar
```

An example of the most basic way to connect to database is as follows.

```
EXEC SQL BEGIN DECLARE SECTION;
char username[10];
char password[10];
EXEC SQL END DECLARE SECTION;
strcpy( username, "test" );
strcpy( password, "test" );
...
EXEC SQL CONNECT :username IDENTIFIED BY :password;
```

GOLDILOCKS supports both D/A mode and C/S mode. The D/A mode is operated by attaching directly to the shared memory, and C/S mode is operated by connecting to the database by using TCP communicati

on. When operated in D/A mode, it is not necessary to include a separate server information as described above because the direct access from the same host of the database is performed. When operated in C/S mode, Data Source Name (DSN) should be specified to access. For more information about DSN, refer to **Data Source Configuration**.

connection\_string information should be given to use DSN. USING clause is used to use connection\_string information. An example of the connection statement whose DSN is "GOLDILOCKS", and using USING clause is as follows.

```
EXEC SQL BEGIN DECLARE SECTION;
char username[10];
char password[10];
char conn_str[20];
EXEC SQL END DECLARE SECTION;
strcpy( username, "test" );
strcpy( password, "test" );
strcpy( conn_str, "DSN=GOLDILOCKS" );
...
EXEC SQL CONNECT :username IDENTIFIED BY :password USING :conn_str;
```

When developing an application, sometimes it is required to uniquely identify the respective connection. It is the case of which each connection is performed in the multi-thread program in D/A mode. Or it is the case of which several connections are performed in C/S mode. The name is given to each connection by using AT clause.

AT clause may be positioned in front of CONNECT statement or USING clause. The example of AT clause in CONNECT statement is as follows.

```
EXEC SQL BEGIN DECLARE SECTION;
char username[10];
char password[10];
char conn_str[20];
char conn_name[10];
EXEC SQL END DECLARE SECTION;
strcpy( username, "test" );
strcpy( password, "test" );
strcpy( conn_str, "DSN=GOLDILOCKS" );
strcpy( conn_name, "DBCONN1" );
...
EXEC SQL CONNECT :username IDENTIFIED BY :password AT :conn_name USING :conn_str;
```

## Disconnecting Database

It disconnects the connection to the database in the application. Like as the CONNECT statement, the disconnect is performed for the default connection or it is performed by giving a connection name. The syntax for disconnecting all connections performed in the application is also provided.

### Single Disconnection

There are two ways of disconnecting a single connection, which are explicit and implicit method. The explicit method uses DISCONNECT statement as follows.

```
EXEC SQL [ AT <db_name> ] DISCONNECT;
```

The transaction is terminated via commit or rollback. The implicit disconnection is performed by adding RELEASE option after the transaction termination statement.

```
EXEC SQL [ AT <db_name> ] { COMMIT/ROLLBACK } [ WORK ] RELEASE;
```

### All Disconnection

All connections of the current application are disconnected all together as follows.

```
EXEC SQL DISCONNECT ALL;
```

## Transaction

Database application consists of transaction units. Therefore, an embedded SQL program should be able to manipulate the transaction. This chapter describes how to manipulate the transaction.

### Start and End of Transaction

A transaction starts in the SQL which is performed first after it is connected. The transaction is maintained until the end command explicitly occurs. There are two end commands, which are COMMIT and ROLLBACK.

#### COMMIT

The transaction commit command causes the following actions.

- All data changes after the current transaction started are permanently reflected in the database.
- The reflected changes are visibly applied to all transactions which started after the changes or to the sensitive cursor.

- All savepoints which are created in the current transaction are deleted.
- All locks which are obtained in the current transaction are released.
- All cursors which are opened in the current transaction are closed. (The holdable cursor is excluded.)
- The transaction is terminated.

The commit command is used as follows.

```
EXEC SQL COMMIT [ WORK ];
```

## ROLLBACK

The rollback command types are as follows.

- Transaction full rollback
- Transaction partial rollback
- Statement-level rollback

The transaction rollback command causes the following actions.

- All data changes after the current transaction started are undone and it returns to the state of before the transaction starts.
- All savepoints which are created in the current transaction are deleted.
- All locks which are obtained in the current transaction are released.
- All cursors which are opened in the current transaction are closed. (The holdable cursor is excluded.)
- The transaction is terminated.

The rollback command is used as follows.

```
EXEC SQL ROLLBACK [ WORK ];
```

Transaction partial rollback uses the savepoint. The application developer explicitly specifies the savepoint, and the transaction partial rollback is implemented by undoing all operations up to the savepoint. The transaction partial rollback command causes the following actions.

- All changes after the rollback savepoint are undone.
- All savepoints created after the rollback savepoint are deleted.
- All locks obtained after the rollback savepoint are released.

Transaction partial rollback command is used as follows.

```
EXEC SQL ROLLBACK TO SAVEPOINT <savepoint_name>;
```

Statement-level rollback undoes only the statement which is currently executed. For example, as if rows are inserted to a table and the unique violation occurs so the current statement can not be performed, the

n only the currently executed statement should be undone so that the next operation may continue.

In this case, there is not a command to be explicitly specified by the user because GOLDILOCKS internally undoes the statement.

## Auto Commit

If the embedded SQL of GOLDILOCKS generally performs the connection, transaction is operated in non auto-commit mode.

However, it may be required to adjust the auto-commit mode for the convenience of application development or for the logical environment of the application. The embedded SQL precompiler of GOLDILOCKS may turn on or off the auto-commit mode with the following syntax.

```
EXEC SQL [ AT <db_name> ] ATUTOCOMMIT { ON | OFF };
```

## RELEASE Option

The currently used connection may be turned off by using the RELEASE option when ending the transaction (commit/ rollback).

The option is allowed to be applied only for the transaction full commit rollback. It can not be used for the transaction partially rollback (ROLLBACK TO SAVEPOINT).

## Host Variables and Datatypes

The embedded SQL application aims at manipulating the data and querying to obtain the desired results by interworking with the database server.

A method for the application data to be transferred to the database server, or vice versa, is required for this operation. The method to perform this role is defined as a host variable.

The application can use the host variables in the same way as C variables because the host variable is declared as a variable of C language. A host variable is treated as a part of the SQL statement and is responsible for the input/output of value between the database server and applications.

## Declaring Host Variable

Host variable should be declared in the embedded SQL directive as follows.

```
EXEC SQL BEGIN DECLARE SECTION;
```

- Declaring a host variable

```
EXEC SQL END DECLARE SECTION;
```

The section above is called as a declare section, and host variables can be declared within the declare section in the same way as C variables. The following is an example of declaring a part of host variables.

```
EXEC SQL BEGIN DECLARE SECTION;
    int    empno;
    char   ename[20];
    double salary;
EXEC SQL END DECLARE SECTION;
```

## Declaring Function Argument

When using the function argument as a host variable, it is required to provide the information about the function argument. This information should be declared within the next embedded SQL directive.

```
EXEC SQL BEGIN ARGUMENT SECTION;
```

- Declaring a host variable

```
EXEC SQL END ARGUMENT SECTION;
```

The section above is called as an argument section, and the host variable should be declared as same as the function argument's name and its type within the argument section.

```
void func( int empno, char ename[20], double salary )
{
EXEC SQL BEGIN ARGUMENT SECTION;
    int    empno;
    char   ename[20];
    double salary;
EXEC SQL END ARGUMENT SECTION;
    ...
}
```

A pseudo type can not be used literally as a function argument, but it can be used by using the declare section and typedef keyword.

```
EXEC SQL BEGIN DECLARE SECTION;
typedef VARCHAR domainName[20];
EXEC SQL END DECLARE SECTION;
```

```

void func( int * no, domainName * name )
{
    EXEC SQL BEGIN ARGUMENT SECTION;
    int      no[20];
    domainName name[20];
    EXEC SQL END ARGUMENT SECTION;
    EXEC SQL INSERT INTO EMP VALUES ( :no, :name );
}

```



If the host variable is declared as a pointer type, then the array length is unknown. Even when the function argument is a pointer type, then the array length of the host variable should be specified in the argument section.

## C Data Type for Host Variable

There are two types of C data used as the host variables, and which are a native type provided by the C language and a data type additionally provided by GOLDILOCKS. The following table describes the data types provided by the embedded SQL of GOLDILOCKS.

### C Native Datatype

C native datatype is the default data type provided by the C language, and its range and size are entirely dependent on the application development platform.

**Table 33-1** C native datatype

C datatype	Description
char	It is a single character.
char[n]	It is a string with maximum length n.
short	It is a small integer (2 bytes).
int	It is an integer (4 bytes).
long	It is a large integer (4/8 bytes).
long long	It is a very large integer (8 bytes).
float	It is a single precision floating-point number.
double	It is a double precision floating-point number.

- char

char type represents a single character.

- char[n]

char[n] represents a string with maximum length n.

The following is an example.

```
EXEC SQL BEGIN DECLARE SECTION;
char strName[20];
EXEC SQL BEGIN DECLARE SECTION;
```

If it is declared as above, strName represents to the string data with the maximum length 20.

If strName is used as an output of ESQL, then it is space padded.



The maximum length of a char[] can not exceed 2001.

- short

It represents 2 bytes integer datatype.

- int

It represents 4 bytes integer datatype.

- long

Long type means a large integer, but the range of the actual value is determined in accordance with the platform. Long is 8 bytes integer in 64 bits Unix/Linux platform, but it is 4 bytes integer in 32 bits Unix/Linux platform.

- long long

It means very large integer, and it represents the 8 bytes integer.

- float

It is the float type of C language, and it represents the 4 bytes single-precision floating-point number.

- double

It is the double type of C language, and it represents the double-precision floating-point number.

## Pseudo Datatype

Pseudo type supports the various forms of GOLDILOCKS type, and it is the type provided by GOLDILOCKS embedded SQL precompiler for the convenience of development. Most of its contents are implemented by using the structure of C.



**Table 33-2** GOLDILOCKS embedded SQL pseudo type

Pseudo type	Description
VARCHAR[n]	It is a variable-length string with the maximum length n.
LONG VARCHAR	It is a variable-length string with the maximum length 100M (104857600).
BINARY[n]	It is a binary data with the maximum length n.
VARBINARY[n]	It is a variable-length binary data with the maximum length n.
LONG VARBINARY	It is a variable-length binary data with the maximum length 100M (104857600).
NUMBER	It is an integer whose number of significant digits is 38.
NUMBER(p)	It is an integer whose number of significant digits is p.
NUMBER(p, s)	It is a real number whose number of significant digits is p and whose scale is s.
BOOLEAN	It is a boolean type.
DATE	It is a date type data.
TIME	It is a time type data.
TIME WITH TIMEZONE	It is a time type data with timezone.
TIMESTAMP	It is a datetime type data.
TIMESTAMP WITH TIMEZONE	It is a time type data with timezone.
INTERVAL YEAR	It is an interval data type.
INTERVAL MONTH	
INTERVAL DAY	
INTERVAL HOUR	
INTERVAL MINUTE	
INTERVAL SECOND	
INTERVAL YEAR TO MONTH	
INTERVAL DAY TO HOUR	
INTERVAL DAY TO MINUTE	
INTERVAL DAY TO SECOND	
INTERVAL HOUR TO MINUTE	
INTERVAL HOUR TO SECOND	
INTERVAL MINUTE TO SECOND	

## VARCHAR

VARCHAR type is the datatype in which the variable length string can be stored, and it consists of the following structure.

```
struct {
    int len;
    char arr[n];
}
```

n refers to the maximum length of VARCHAR type.

```
EXEC SQL BEGIN DECLARE SECTION;
    VARCHAR varstr[100];
EXEC SQL END DECLARE SECTION;
```

For example, if it is declared as above, it is converted via precompile process as follows.

```
struct VARCHAR_varstr {
    int len;
    char arr[100];
} varstr;
```

The application can use VARCHAR type as follows.

```
strcpy( varstr.arr, "abcde" );
varstr.len = strlen( varstr.arr );

EXEC SQL INSERT INTO TEST_T1 VALUES ( :varstr );
```



The length of VARCHAR can not exceed 4000.

## LONG VARCHAR

LONG VARCHAR type is the datatype in which a long variable-length strings can be stored, and it consists of the following structure.

```
typedef struct SQL_LONG_VARIABLE_LENGTH_STRUCT
{
    SQLBIGINT len;
    SQLCHAR * arr;
} SQL_LONG_VARIABLE_LENGTH_STRUCT;
```

LONG VARCHAR type can be declared as follows.

```
EXEC SQL BEGIN DECLARE SECTION;
    LONGVARCHAR long_text[1048576];
EXEC SQL END DECLARE SECTION;
```

LONG VARCHAR is different from VARCHAR. LONG VARCHAR can have the length up to 100M (104857600), so it does not pre-allocate the space for the string when declaring. After declaring LONG VARCHAR, the memory space should be allocated in long\_text.arr before actual use, and the application should release the allocated memory space. An example of using LONG VARCHAR is as follows.

```

long_text.arr = malloc( 1048576 );

gets( long_text.arr );
long_text.len = strlen( long_text.arr );

EXEC SQL INSERT INTO TEST_T1 VALUES ( :long_text );
...
free( long_text.arr );

```



LONG VARCHAR type can be declared by specifying the current length up to 100M (10485760).

## BINARY

BINARY type is the datatype to literally handle the non-formal raw data, and it consists of the following structure. The example of declaring BINARY type is as follows.

```

EXEC SQL BEGIN DECLARE SECTION;
    VARCHAR binary[100];
EXEC SQL END DECLARE SECTION;

```

If it is declared as above, it is converted via precompile process as follows.

```
char binary[100];
```

Its form is as same as the character string storage form. char[n] is defined to store the string of database, but BINARY type is for storing the binary data. Therefore, the applications can use BINARY type in the same way as dealing with the character string data.



The maximum length of BINARY can not exceed 2000.

## VARBINARY

VARBINARY type is the datatype in which the variable length binary data can be stored, and it consists of the following structure.

```

struct {
    int len;
    char arr[n];
}

```

n refers to the maximum length of VARCHAR type.

```
EXEC SQL BEGIN DECLARE SECTION;
    VARCHAR varbin[100];
EXEC SQL END DECLARE SECTION;
```

For example, if it is declared as above, it is converted via precompile process as follows.

```
struct VARBINARY_varbin {
    int len;
    char arr[100];
} varbin;
```

The forms of VARBINARY type and VARCHAR type are same. VARCHAR is for storing the string data, but VARBINARY is for storing the binary data. VARCHAR and VARBINARY are same in all other aspects except for the aspect above. Therefore, the application can use both VARCHAR and VARBINARY types as follows.

```
memcpy( varbin.arr, binary_data, 50 );
varbin.len = 50;

EXEC SQL INSERT INTO TEST_T1 VALUES ( :varbin );
```



The length of VARBINARY can not exceed 4000.

## LONG VARBINARY

LONG VARBINARY type is the datatype in which the long variable length binary data can be stored, and it consists of the following structure.

```
typedef struct SQL_LONG_VARIABLE_LENGTH_STRUCT
{
    SQLBIGINT len;
    SQLCHAR * arr;
} SQL_LONG_VARIABLE_LENGTH_STRUCT;
```

LONG VARBINARY type can be declared as follows.

```
EXEC SQL BEGIN DECLARE SECTION;
    LONGVARBINARY long_bin[1048576];
EXEC SQL END DECLARE SECTION;
```

The difference between LONG VARBINARY and VARBINARY is that the space is not pre-allocated to store binary data when declaring LONG VARBINARY type. (It is as same as the difference between LONG VARCHAR and VARCHAR). After declaring LONG VARBINARY, the memory space should be allocated in long\_bin.arr before actual use, and the application should release the allocated memory space after use. An example of using LONG VARBINARY is as follows.

```
long_bin.arr = malloc( 1048576 );

memcpy( long_bin.arr, long_binary_data, 1048576);
long_bin.len = 1048576;

EXEC SQL INSERT INTO TEST_T1 VALUES ( :long_bin );
...
free( long_bin.arr );
```



LONG VARBINARY type can be declared by specifying the current length up to 100M(104857600).

## NUMBER

NUMBER type is the datatype which provides an SQL\_NUMERIC\_STRUCT defined in ODBC to make it to be used in the application.

```
#define SQL_MAX_NUMERIC_LEN 16
typedef struct tagSQL_NUMERIC_STRUCT
{
    SQLCHAR precision;
    SQLSCHAR scale;
    SQLCHAR sign; /* 1=pos 0=neg */
    SQLCHAR val[SQL_MAX_NUMERIC_LEN];
} SQL_NUMERIC_STRUCT;
```

NUMBER type is configured to express the real number type data with precision and scale. When declaring NUMBER type, precision and scale can also be declared. Scale and precision can be omitted as follows in some cases.

**Table 33-3** Scale and precision of number types

Declaring NUMBER type	Description
NUMBER	It is as same as NUMBER(38, 0).
NUMBER(p)	It is as same as NUMBER(p, 0)
NUMBER(p, s)	It is a real number type data with precision p, scale s.

```
EXEC SQL BEGIN DECLARE SECTION;
    NUMBER          number_default;
    NUMBER(20)      number_20;
    NUMBER(30,10)   number_30_10;
EXEC SQL END DECLARE SECTION;
```

For example, if the variable is declared as above, number\_default variable is as same as the declaration of NUMBER(38, 0), and number\_20 variable is as same as the declaration of NUMBER(20, 0). NUMBER type uses SQL\_NUMERIC\_STRUCT which is a ODBC type. The following is a sample of using NUMBER type.

```
/*
 * number.gc
 */
#include <stdio.h>
#include <stdlib.h>
#include <string.h>
EXEC SQL INCLUDE SQLCA;
#define SUCCESS 0
#define FAILURE -1
#define PRINT_SQL_ERROR(aMsg) \
    { \
        printf("\n"); \
        printf(aMsg); \
        printf("\nSQLCODE : %d\nSQLSTATE : %s\nERROR MSG : %s\n", \
            sqlca.sqlcode, \
            SQLSTATE, \
            sqlca.sqlerrm.sqlerrmc ); \
    }

int Connect(char *aHostInfo, char *aUserID, char *sPassword);
int CreateTable();
int DropTable();

unsigned long long ConvertMantisaToDecimal(SQLCHAR *aNumStrValue)
{
    unsigned long long sResult = 0;
    unsigned long long sLast=1;
    unsigned int sCurrent;
    unsigned int sLSD = 0;
    unsigned int sMSD = 0;
```

```

int      i      = 1;
for(i = 0; i < SQL_MAX_NUMERIC_LEN; i ++)
{
    sCurrent = (unsigned char) aNumStrValue[i];
    sLSD = sCurrent % 16; //Obtain LSD
    sMSD = sCurrent / 16; //Obtain MSD
    sResult += sLast * sLSD;
    sLast = sLast * 16;
    sResult += sLast * sMSD;
    sLast = sLast * 16;
}
return sResult;
}

void PrintNumber(SQL_NUMERIC_STRUCT *aNumber)
{
    unsigned long long  sDigit;
    unsigned long long  sFraction;
    unsigned long long  sMantisa;
    unsigned long long  sFactor;
    int      i;
    sMantisa = ConvertMantisaToDecimal( aNumber->val );
    sFactor = 1;
    for( i = 0; i < aNumber->scale; i ++ )
    {
        sFactor *= 10;
    }
    sDigit = sMantisa / sFactor;
    sFraction = sMantisa % sFactor;
    if( sFraction != 0 )
    {
        printf("%llu.%-3llu", sDigit, sFraction);
    }
    else
    {
        printf("%llu", sDigit);
    }
}

int main(int      argc,
          char    **argv)

```

```

{
EXEC SQL BEGIN DECLARE SECTION;
NUMBER          sNumber;
NUMBER(10,5)    sResultNumber1;
NUMBER(10,5)    sResultNumber2;
char            sCharNumber[20];
int             sNo;
int             sResultNo;
EXEC SQL END DECLARE SECTION;

int i;
int sState = 0;
printf("#### Number Datatype Test ####\n");
printf("Connect GOLDILOCKS ...\n");
if(Connect("DSN=GOLDILOCKS", "test", "test") != SUCCESS)
{
    goto fail_exit;
}
printf("Create table ...\n");
if(CreateTable() != SUCCESS)
{
    goto fail_exit;
}
sState = 1;
printf("Insert record ...\n");
for(i = 0; i < 20; i ++)
{
    sNo = i + 1;
    memset( &sNumber, 0x00, sizeof(SQL_NUMERIC_STRUCT) );
    sNumber.precision = 38;
    sNumber.scale = 3;
    sNumber.sign = 1;
    /*
    * 0x627d = 25213
    */
    sNumber.val[0] = 0x7d + i;
    sNumber.val[1] = 0x62;
    snprintf( sCharNumber, 20, "25.2%02d", 13 + i );
EXEC SQL
    INSERT INTO TEST_T1(C1, C2, C3)
    VALUES(:sNo, :sNumber, :sCharNumber);
    if(sqlca.sqlcode != 0)

```



```

        {
            goto fail_exit;
        }
    }
EXEC SQL COMMIT WORK;
if(sqlca.sqlcode != 0)
{
    goto fail_exit;
}
printf("Retrive record\n");
EXEC SQL
    DECLARE CUR1 CURSOR FOR
    SELECT C1, C2, C3
    FROM TEST_T1;
EXEC SQL OPEN CUR1;
if(sqlca.sqlcode != 0)
{
    goto fail_exit;
}
printf(" NO   Number1  Number2\n");
printf("==== =====\n");
memset( &sResultNumber1, 0x00, sizeof(SQL_NUMERIC_STRUCT) );
memset( &sResultNumber2, 0x00, sizeof(SQL_NUMERIC_STRUCT) );
while( 1 )
{
    EXEC SQL
        FETCH FROM CUR1
        INTO :sResultNo, :sResultNumber1, :sResultNumber2;
    if(sqlca.sqlcode == SQL_NO_DATA)
    {
        /*
         * No more data
         */
        break;
    }
    if(sqlca.sqlcode != 0)
    {
        goto fail_exit;
    }
    printf("%3d  ", sResultNo);
    PrintNumber( &sResultNumber1 );
}

```

```

        printf(" ");
        PrintNumber( &sResultNumber2 );
        printf("\n");
    }
    printf("==== ===== \n");
    EXEC SQL CLOSE CUR1;
    if(sqlca.sqlcode != 0)
    {
        goto fail_exit;
    }
    EXEC SQL COMMIT WORK;
    if(sqlca.sqlcode != 0)
    {
        goto fail_exit;
    }
    sState = 0;
    printf("Drop table ...\n");
    if(DropTable() != SUCCESS)
    {
        goto fail_exit;
    }
    printf("Disconnect GOLDILOCKS ...\n");
    EXEC SQL COMMIT WORK RELEASE;
    printf("SUCCESS\n");
    printf("#####\n");
    return 0;
fail_exit:
    PRINT_SQL_ERROR("[ERROR] SQL ERROR -");
    printf("FAILURE\n");
    printf("#####\n\n");
    switch(sState)
    {
        case 1:
            printf("Drop table ...\n");
            (void)DropTable();
        default:
            break;
    }
    EXEC SQL ROLLBACK WORK RELEASE;
    return 0;
}

```

```

int CreateTable()
{
    EXEC SQL DROP TABLE IF EXISTS TEST_T1;
    if(sqlca.sqlcode != 0)
    {
        goto fail_exit;
    }
}

```

- Create table

```

EXEC SQL CREATE TABLE TEST_T1 ( C1 INTEGER,
                                C2 NUMERIC(38,4),
                                C3 VARCHAR(20) );

    if(sqlca.sqlcode != 0)
    {
        goto fail_exit;
    }
EXEC SQL COMMIT WORK;
if(sqlca.sqlcode != 0)
{
    goto fail_exit;
}
return SUCCESS;
fail_exit:
    PRINT_SQL_ERROR("[ERROR] SQL ERROR -");
EXEC SQL ROLLBACK WORK;
return FAILURE;
}

```

- Drop table

```

int DropTable()
{
    EXEC SQL DROP TABLE TEST_T1;
    if(sqlca.sqlcode != 0)
    {
        goto fail_exit;
    }
EXEC SQL COMMIT WORK;
if(sqlca.sqlcode != 0)
{

```

```

        goto fail_exit;
    }
    return SUCCESS;
fail_exit:
    PRINT_SQL_ERROR("[ERROR] SQL ERROR -");
    EXEC SQL ROLLBACK WORK;
    return FAILURE;
}

int Connect(char *aHostInfo, char *aUserID, char *sPassword)
{
    EXEC SQL BEGIN DECLARE SECTION;
    VARCHAR sUid[80];
    VARCHAR sPwd[20];
    VARCHAR sConnStr[1024];
    EXEC SQL END DECLARE SECTION;

```

- Log on GOLDILOCKS

```

strcpy((char *)sUid.arr, aUserID);
sUid.len = (short)strlen((char *)sUid.arr);
strcpy((char *)sPwd.arr, sPassword);
sPwd.len = (short)strlen((char *)sPwd.arr);
strcpy((char *)sConnStr.arr, aHostInfo);
sConnStr.len = (short)strlen((char *)sConnStr.arr);

```

- DB connection

```

EXEC SQL CONNECT :sUid IDENTIFIED BY :sPwd USING :sConnStr;
    if(sqlca.sqlcode != 0)
    {
        goto fail_exit;
    }
    return SUCCESS;
fail_exit:
    PRINT_SQL_ERROR("[ERROR] Connection Failure!");
    return FAILURE;
}

```

## BOOLEAN

BOOLEAN type has the value of TRUE or FALSE. Actually, the variable is used as the variable of C language, so if the variable is 1, it refers to TRUE. If the variable is 0, it refers to FALSE.

The following is an example of using a simple BOOLEAN type variable.

```
EXEC SQL BEGIN DECLARE SECTION;
    BOOLEAN boolean;
EXEC SQL END DECLARE SECTION;

EXEC SQL SELECT IsEnable INTO :boolean FROM STATUS WHERE ID = 100;

if( boolean != 0 )
{
    print( "Enable Status : TRUE\n" );
}
else
{
    print( "Enable Status : FALSE\n" );
}
```

## DATE

Date type can deal with dates and times. Date type has SQL\_TIMESTAMP\_STRUCT structure of ODBC.

```
typedef struct tagTIMESTAMP_STRUCT
{
    SQLSMALLINT    year;
    SQLUSMALLINT   month;
    SQLUSMALLINT   day;
    SQLUSMALLINT   hour;
    SQLUSMALLINT   minute;
    SQLUSMALLINT   second;
    SQLINTEGER     fraction;
} TIMESTAMP_STRUCT;

typedef TIMESTAMP_STRUCT SQL_TIMESTAMP_STRUCT;
```

If the variable of DATE type is declared, the precompiler converts it to the structure above, and the meaning of each field as same as SQL\_TIMESTAMP\_STRUCT of ODBC.

## TIME

TIME type is the datatype which deals with time, and it has SQL\_TIME\_STRUCT structure of ODBC.

```
typedef struct tagTIME_STRUCT
{
    SQLUSMALLINT    hour;
    SQLUSMALLINT    minute;
    SQLUSMALLINT    second;
} TIME_STRUCT;
typedef TIME_STRUCT SQL_TIME_STRUCT;
```

If the variable of TIME type is declared, the precompiler converts it to the structure above, and the meaning of each field is as same as SQL\_TIME\_STRUCT of ODBC.

## TIME WITH TIMEZONE

TIME WITH TIMEZONE type is the datatype which deals with the time with timezone, and it has the structure as follows.

```
typedef struct tagTIME_WITH_TIMEZONE_STRUCT
{
    SQLUSMALLINT    hour;
    SQLUSMALLINT    minute;
    SQLUSMALLINT    second;
    SQLINTEGER      fraction;
    SQLSMALLINT     timezone_hour;
    SQLSMALLINT     timezone_minute;
} TIME_WITH_TIMEZONE_STRUCT;
typedef TIME_WITH_TIMEZONE_STRUCT SQL_TIME_WITH_TIMEZONE_STRUCT;
```

If the variable of TIME WITH TIMEZONE type is declared, precompiler converts it to the structure above, and the meaning of each field is as follows.

**Table 33-4** Fields of TIME WITH TIMEZONE

Field name	Description
hour	hour
minute	minute
second	second
fraction	the seconds below the decimal point
timezone_hour	hour of timezone
timezone_minute	minute of timezone

## TIMESTAMP

TIMESTAMP type is the datatype which deals with date ~ time, and it has SQL\_TIMESTAMP\_STRUCT structure of ODBC.

```
typedef struct tagTIMESTAMP_STRUCT
{
    SQLSMALLINT    year;
    SQLUSMALLINT   month;
    SQLUSMALLINT   day;
    SQLUSMALLINT   hour;
    SQLUSMALLINT   minute;
    SQLUSMALLINT   second;
    SQLINTEGER      fraction;
} TIMESTAMP_STRUCT;
typedef TIMESTAMP_STRUCT SQL_TIMESTAMP_STRUCT;
```

If the variable of TIMESTAMP type is declared, precompiler converts it to the structure above, and the meaning of each field is same as SQL\_TIMESTAMP\_STRUCT structure of ODBC.

## TIMESTAMP WITH TIMEZONE

TIMESTAMP WITH TIMEZONE type is the datatype which deals with timestamp with timezone, and it has the following structure.

```
typedef struct tagTIMESTAMP_WITH_TIMEZONE_STRUCT
{
    SQLSMALLINT    year;
    SQLUSMALLINT   month;
    SQLUSMALLINT   day;
    SQLUSMALLINT   hour;
    SQLUSMALLINT   minute;
    SQLUSMALLINT   second;
    SQLINTEGER      fraction;
    SQLSMALLINT    timezone_hour;
    SQLSMALLINT    timezone_minute;
} TIMESTAMP_WITH_TIMEZONE_STRUCT;
typedef TIMESTAMP_WITH_TIMEZONE_STRUCT SQL_TIMESTAMP_WITH_TIMEZONE_STRUCT;
```

If the variable of TIMESTAMP WITH TIMEZONE type is declared, precompiler converts it to the structure above, and the meaning of each field is as follows.

**Table 33-5** Fields of TIMESTAMP WITH TIMEZONE

Field name	Description
year	year
month	month
day	day
hour	hour
minute	minute
second	second
fraction	the seconds below the decimal point
timezone_hour	hour of timezone
timezone_minute	minute of timezone

The following is an example of dealing with DATE, TIME, TIMESTAMP, TIME WITH TIMEZONE, TIMESTAMP WITH TIMEZONE types.

```

/*
 * date_time.gc
 *
 */
#include <stdio.h>
#include <stdlib.h>
#include <string.h>

EXEC SQL INCLUDE SQLCA;

#define SUCCESS 0
#define FAILURE -1

#define PRINT_SQL_ERROR(aMsg) \
{ \
    printf("\n"); \
    printf(aMsg); \
    printf("\nSQLCODE : %d\nSQLSTATE : %s\nERROR MSG : %s\n", \
        sqlca.sqlcode, \
        SQLSTATE, \
        sqlca.sqlerrm.sqlerrmc ); \
}

int Connect(char *aHostInfo, char *aUserID, char *sPassword);
int CreateTable();
int DropTable();

```



```

int main(int    argc,
         char  **argv)
{
    EXEC SQL BEGIN DECLARE SECTION;
    int          sNo;
    int          sResultNo;
    DATE        sDate, sResultDate;
    TIME        sTime, sResultTime;
    TIME WITH TIMEZONE    sTimeTz, sResultTimeTz;
    TIMESTAMP   sTimestamp, sResultTimestamp;
    TIMESTAMP WITH TIMEZONE    sTimestampTz, sResultTimestampTz;
    EXEC SQL END DECLARE SECTION;
    int  sState = 0;

    printf("#### Datatype Insert Test ####\n");
    printf("Connect GOLDILOCKS ...\n");
    if(Connect("DSN=GOLDILOCKS", "test", "test") != SUCCESS)
    {
        goto fail_exit;
    }
    sState = 1;
    printf("Create table ...\n");
    if(CreateTable() != SUCCESS)
    {
        goto fail_exit;
    }
    sState = 2;
    printf("Insert record ...\n");

    sNo = 1;
    /**
     * Date : 2014-7-14 21:29:30
     */
    sDate.year   = 2014;
    sDate.month  = 7;
    sDate.day    = 14;
    sDate.hour   = 21;
    sDate.minute = 29;
    sDate.second = 30;
    sDate.fraction = 0;

```

```
/**
 * Time : 17:46:35
 */
sTime.hour   = 17;
sTime.minute = 46;
sTime.second = 35;

/**
 * Time With Timezone : 17:46:35.6789(+9:00)
 */
sTimeTz.hour           = 17;
sTimeTz.minute         = 46;
sTimeTz.second         = 35;
sTimeTz.fraction       = 678900000;
sTimeTz.timezone_hour  = 9;
sTimeTz.timezone_minute = 0;

/**
 * Timestamp : 2014-02-13 17:46:28.123
 */
sTimestamp.year      = 2014;
sTimestamp.month     = 2;
sTimestamp.day       = 13;
sTimestamp.hour      = 17;
sTimestamp.minute    = 46;
sTimestamp.second    = 28;
sTimestamp.fraction  = 123000000;

/**
 * Time With Timezone : 2014-05-18 17:46:35.001(+9:00)
 */
sTimestampTz.year    = 2014;
sTimestampTz.month   = 5;
sTimestampTz.day     = 18;
sTimestampTz.hour    = 17;
sTimestampTz.minute  = 46;
sTimestampTz.second  = 35;
sTimestampTz.fraction = 1000000;
sTimestampTz.timezone_hour = 9;
sTimestampTz.timezone_minute = 0;
```

```

/**
 * Insert record
 */
EXEC SQL
    INSERT INTO TEST_T1(C1, C2, C3, C4, C5, C6)
    VALUES(:sNo, :sDate, :sTime, :sTimeTz, :sTimestamp, :sTimestampTz);
if(sqlca.sqlcode != 0)
{
    goto fail_exit;
}

EXEC SQL COMMIT WORK;
if(sqlca.sqlcode != 0)
{
    goto fail_exit;
}

printf("Retrive record\n");
EXEC SQL
    SELECT C1, C2, C3, C4, C5, C6
    INTO   :sResultNo, :sResultDate, :sResultTime, :sResultTimeTz, :sResultTimestamp,
:sResultTimestampTz
    FROM   TEST_T1
    WHERE  C1 = 1;
if(sqlca.sqlcode != 0)
{
    goto fail_exit;
}

printf("=====\n");
printf( "DATE                : %04d-%02d-%02d %02d:%02d:%02d\n",
        sResultDate.year,
        sResultDate.month,
        sResultDate.day,
        sResultDate.hour,
        sResultDate.minute,
        sResultDate.second );

printf( "TIME                : %02d:%02d:%02d\n",
        sResultTime.hour,

```

```
        sResultTime.minute,
        sResultTime.second );

printf( "TIME WITH TIMEZONE      : %02d:%02d:%02d.%09u(GMT %+02d:%02d)\n",
        sResultTimeTz.hour,
        sResultTimeTz.minute,
        sResultTimeTz.second,
        sResultTimeTz.fraction,
        sResultTimeTz.timezone_hour,
        sResultTimeTz.timezone_minute );

printf( "TIMESTAMP                : %04d-%02d-%02d %02d:%02d:%02d.%09u\n",
        sResultTimestamp.year,
        sResultTimestamp.month,
        sResultTimestamp.day,
        sResultTimestamp.hour,
        sResultTimestamp.minute,
        sResultTimestamp.second,
        sResultTimestamp.fraction );

printf( "TIMESTAMP WITH TIMEZONE: %04d-%02d-%02d %02d:%02d:%02d.%09u(GMT %+02d:%02d)\n",
        sResultTimestampTz.year,
        sResultTimestampTz.month,
        sResultTimestampTz.day,
        sResultTimestampTz.hour,
        sResultTimestampTz.minute,
        sResultTimestampTz.second,
        sResultTimestampTz.fraction,
        sResultTimestampTz.timezone_hour,
        sResultTimestampTz.timezone_minute );

printf("=====\n");

sState = 0;
printf("Drop table ...\n");
if(DropTable() != SUCCESS)
{
    goto fail_exit;
}

sState = 0;
```

```

printf("Disconnect GOLDILOCKS ...\\n");
EXEC SQL COMMIT WORK RELEASE;

printf("SUCCESS\\n");
printf("#####\\n");

return 0;

fail_exit:
printf("\\n");
PRINT_SQL_ERROR("[ERROR] SQL ERROR -");

printf("FAILURE\\n");
printf("#####\\n\\n");

switch(sState)
{
    case 1:
        printf("Drop table ...\\n");
        (void)DropTable();
    default:
        break;
}

EXEC SQL ROLLBACK WORK RELEASE;

return 0;
}

int CreateTable()
{
    EXEC SQL DROP TABLE IF EXISTS TEST_T1;
    if(sqlca.sqlcode != 0)
    {
        goto fail_exit;
    }
}

```

- Create table

```

EXEC SQL CREATE TABLE TEST_T1 ( C1 INTEGER,
                                C2 DATE,

```

```

C3 TIME,
C4 TIME WITH TIME ZONE,
C5 TIMESTAMP,
C6 TIMESTAMP WITH TIME ZONE );

if(sqlca.sqlcode != 0)
{
    goto fail_exit;
}

EXEC SQL COMMIT WORK;
if(sqlca.sqlcode != 0)
{
    goto fail_exit;
}

return SUCCESS;

fail_exit:
PRINT_SQL_ERROR("[ERROR] SQL ERROR -");

EXEC SQL ROLLBACK WORK;

return FAILURE;
}

```

- Drop table

```

int DropTable()
{
    EXEC SQL DROP TABLE TEST_T1;
    if(sqlca.sqlcode != 0)
    {
        goto fail_exit;
    }

    EXEC SQL COMMIT WORK;
    if(sqlca.sqlcode != 0)
    {
        goto fail_exit;
    }
}

```

```

    return SUCCESS;

fail_exit:
    PRINT_SQL_ERROR("[ERROR] SQL ERROR -");

    EXEC SQL ROLLBACK WORK;

    return FAILURE;
}

int Connect(char *aHostInfo, char *aUserID, char *sPassword)
{
    EXEC SQL BEGIN DECLARE SECTION;
    VARCHAR sUid[80];
    VARCHAR sPwd[20];
    VARCHAR sConnStr[1024];
    EXEC SQL END DECLARE SECTION;

```

- Log on GOLDILOCKS

```

strcpy((char *)sUid.arr, aUserID);
sUid.len = (short)strlen((char *)sUid.arr);
strcpy((char *)sPwd.arr, sPassword);
sPwd.len = (short)strlen((char *)sPwd.arr);
strcpy((char *)sConnStr.arr, aHostInfo);
sConnStr.len = (short)strlen((char *)sConnStr.arr);

```

- DB connection

```

EXEC SQL CONNECT :sUid IDENTIFIED BY :sPwd USING :sConnStr;
    if(sqlca.sqlcode != 0)
    {
        goto fail_exit;
    }

    return SUCCESS;

fail_exit:
    PRINT_SQL_ERROR("[ERROR] Connection Failure!");

    return FAILURE;
}

```

## INTERVAL Types

INTERVAL types are the datatypes which represent the time interval between two times. They are divided into year ~ month family type and day ~ second family type. They are subdivided by specific types of each family.

The following table describes the detailed classification of INTERVAL type.

**Table 33-6** Classification of INTERVAL type

Family	Detailed type	Description
YEAR TO MONTH	INTERVAL YEAR	It is an interval in terms of years.
	INTERVAL MONTH	It is an interval in terms of months.
	INTERVAL YEAR TO MONTH	It is an interval in terms of years to months.
DAY TO SECOND	INTERVAL DAY	It is an interval in terms of days.
	INTERVAL HOUR	It is an interval in terms of hours.
	INTERVAL MINUTE	It is an interval in terms of minutes.
	INTERVAL SECOND	It is an interval in terms of seconds.
	INTERVAL DAY TO HOUR	It is an interval in terms of days to hours.
	INTERVAL DAY TO MINUTE	It is an interval in terms of days to minutes.
	INTERVAL DAY TO SECOND	It is an interval in terms of days to seconds.
	INTERVAL HOUR TO MINUTE	It is an interval in terms of hours to minutes.
	INTERVAL HOUR TO SECOND	It is an interval in terms of hours to seconds.
INTERVAL MINUTE TO SECOND	It is an interval in terms of minutes to seconds.	

INTERVAL type has the structure of SQL\_INTERVAL\_STRUCT of ODBC as follows.

```
typedef enum
{
    SQL_IS_YEAR          = 1,
    SQL_IS_MONTH         = 2,
    SQL_IS_DAY           = 3,
    SQL_IS_HOUR          = 4,
    SQL_IS_MINUTE        = 5,
    SQL_IS_SECOND        = 6,
    SQL_IS_YEAR_TO_MONTH = 7,
    SQL_IS_DAY_TO_HOUR   = 8,
    SQL_IS_DAY_TO_MINUTE = 9,
    SQL_IS_DAY_TO_SECOND = 10,
    SQL_IS_HOUR_TO_MINUTE = 11,
    SQL_IS_HOUR_TO_SECOND = 12,
    SQL_IS_MINUTE_TO_SECOND = 13
} SQLINTERVAL;
```



```

typedef struct tagSQL_YEAR_MONTH
{
    SQLINTEGER    year;
    SQLINTEGER    month;
} SQL_YEAR_MONTH_STRUCT;
typedef struct tagSQL_DAY_SECOND
{
    SQLINTEGER    day;
    SQLINTEGER    hour;
    SQLINTEGER    minute;
    SQLINTEGER    second;
    SQLINTEGER    fraction;
} SQL_DAY_SECOND_STRUCT;
typedef struct tagSQL_INTERVAL_STRUCT
{
    SQLINTERVAL   interval_type;
    SQLSMALLINT   interval_sign;
    union {
        SQL_YEAR_MONTH_STRUCT   year_month;
        SQL_DAY_SECOND_STRUCT   day_second;
    } intval;
} SQL_INTERVAL_STRUCT;

```

All INTERVAL types listed above have the same structure. For each INTERVAL type, a valid field is separately distinguished within the structure. INTERVAL type is distinguished by interval\_type field within the structure, and a real INTERVAL value is represented to intval union in the structure. The field which is used in intval union is different by each type, and the following table describes the valid field depending on the type.

**Table 33-7** The valid field depending on INTERVAL type

Type	?.interval_type	?.intval valid field
INTERVAL YEAR	SQL_IS_YEAR	*.year_month.year
INTERVAL MONTH	SQL_IS_MONTH	*.year_month.month
INTERVAL YEAR TO MONTH	SQL_IS_YEAR_TO_MONTH	*.year_month.year *.year_month.month
INTERVAL DAY	SQL_IS_DAY	*.day_second.day
INTERVAL HOUR	SQL_IS_HOUR	*.day_second.hour
INTERVAL MINUTE	SQL_IS_MINUTE	*.day_second.minute
INTERVAL SECOND	SQL_IS_SECOND	*.day_second.second *.day_second.fraction
INTERVAL DAY TO HOUR	SQL_IS_DAY_TO_HOUR	*.day_second.day

Type	?interval_type	?intval valid field
		*.day_second.hour
INTERVAL DAY TO MINUTE	SQL_IS_DAY_TO_MINUTE	*.day_second.day *.day_second.hour *.day_second.minute
INTERVAL DAY TO SECOND	SQL_IS_DAY_TO_SECOND	*.day_second.day *.day_second.hour *.day_second.minute *.day_second.second *.day_second.fraction
INTERVAL HOUR TO MINUTE	SQL_IS_HOUR_TO_MINUTE	*.day_second.hour *.day_second.minute
INTERVAL HOUR TO SECOND	SQL_IS_HOUR_TO_SECOND	*.day_second.hour *.day_second.minute *.day_second.second *.day_second.fraction
INTERVAL MINUTE TO SECOND	SQL_IS_MINUTE_TO_SECOND	*.day_second.minute *.day_second.second *.day_second.fraction

Fraction refers to the seconds below the decimal point. (The fraction field is valid only for INTERVAL type which includes SECOND.)

## Special Type

The special data type provides the additional functionality and convenience for development of application rather than handling the data on its own. The following table describes the special types.

**Table 33-8** Special types

Type	Description
SQL_CONTEXT	It manages run-time context within the multi-connection structure.
Struct	It constitutes a set of column as a structure, and it is used when dealing with row.
Typedef	The previously defined type is redefined as another name.

### SQL\_CONTEXT

SQL\_CONTEXT is a special data type for managing the run-time context. Run-time context is used for the purpose of managing the connection and the individual data related to the connection on the run-time while the application is running.

SQL\_CONTEXT variable is declared as follows.

```
EXEC SQL BEGIN DECLARE SECTION;
SQL_CONTEXT my_context;
EXEC SQL BEGIN DECLARE SECTION;
```

ALLOCATE clause is used after declaring SQL\_CONTEXT variable as follows.

```
EXEC SQL CONTEXT ALLOCATE :my_context;
```

USE clause is used for SQL\_CONTEXT variable.

```
EXEC SQL CONTEXT USE :my_context;
```

USE clause specifies the context to be used, and the following describes how to go back to the default context not the context declared by the application.

```
EXEC SQL CONTEXT USE DEFAULT;
```

The disused SQL\_CONTEXT variable is released as follows.

```
EXEC SQL CONTEXT FREE :my_context;
```

The following is an example of using SQL\_CONTEXT.

```
/*
 * thread1.gc
 *
 */
#include <stdio.h>
#include <stdlib.h>
#include <string.h>
#include <pthread.h>

EXEC SQL INCLUDE SQLCA;

#define SUCCESS 0
#define FAILURE -1

#define PRINT_SQL_ERROR(aMsg) \
    { \
        printf("\n"); \
        printf(aMsg); \
        printf("\nSQLCODE : %d\nSQLSTATE : %s\nERROR MSG : %s\n", \
```

```

        sqlca.sqlcode,          \
        SQLSTATE,              \
        sqlca.sqlerrm.sqlerrmc ); \
    }

int Connect(sql_context aCtx, char *aHostInfo, char *aUserID, char *sPassword);
int CreateEmpTempTable();
int DropEmpTempTable();
void *clientThread(void *args);

typedef struct thread_param
{
    int    mNo;
    char  *mJobName;
} thread_param;

#define  THREAD_COUNT  2
char  gJobName[THREAD_COUNT][20]= {
    "RND",
    "SUPPORT"
};

int main(int argc, char **argv)
{
    EXEC SQL BEGIN DECLARE SECTION;
    int          sEmpNo;
    varchar      sEName[20 + 1];
    char         sJob[20];
    long         sSalary;
    EXEC SQL END DECLARE SECTION;
    int          sRecordCount = 0;
    pthread_t    thread_id[THREAD_COUNT];
    thread_param param[THREAD_COUNT];
    int          i;

    printf("Connect GOLDILOCKS ...\n");
    if(Connect(NULL, "DSN=GOLDILOCKS", "test", "test") != SUCCESS)
    {
        goto fail_exit;
    }
}

```

```

if(CreateEmpTempTable() != SUCCESS)
{
    goto fail_exit;
}

```

- Create client thread

```

for( i = 0; i < THREAD_COUNT; i ++ )
{
    param[i].mNo = i;
    param[i].mJobName = gJobName[i];
    if( pthread_create(&thread_id[i],
                      NULL,
                      clientThread,
                      &param[i]) != 0 )
    {
        printf( "Can't create thread %d!\n", i );
    }
    else
    {
        printf( "Create thread %d!\n", i );
    }
}

for( i = 0; i < THREAD_COUNT; i ++ )
{
    if( pthread_join(thread_id[i],
                    NULL) != 0 )
    {
        printf( "Error when waiting for thread %d to terminate!\n", i );
    }
    else
    {
        printf( "Stopped thread %d!\n", i );
    }
}

```

- Retrieve employee

EXEC SQL

```

DECLARE EMP_CUR CURSOR FOR
SELECT empno, ename, job, sal

```

```

        FROM EMP_TEMP
        ORDER BY empno;

EXEC SQL OPEN EMP_CUR;
if(sqlca.sqlcode != 0)
{
    PRINT_SQL_ERROR("[ERROR] SQL ERROR -");
    goto fail_exit;
}

printf(" EMPNO      ENAME                      JOB      SALARY\n");
printf("===== \n");
while( 1 )
{
    EXEC SQL
        FETCH EMP_CUR
        INTO :sEmpNo, :sENAME, :sJob, :sSalary;
    if(sqlca.sqlcode == SQL_NO_DATA)
    {
        break;
    }
    else if(sqlca.sqlcode != 0)
    {
        PRINT_SQL_ERROR("[ERROR] SQL ERROR -");
        goto fail_exit;
    }

    sRecordCount ++;

    printf("%6d %20s %10s %8ld\n",
           sEmpNo, sENAME.arr, sJob, sSalary);
}

printf("===== \n");
printf("Record Count = %d\n", sRecordCount);
printf("===== \n");

EXEC SQL CLOSE EMP_CUR;
if(sqlca.sqlcode != 0)
{
    PRINT_SQL_ERROR("[ERROR] SQL ERROR -");
}

```

```

        goto fail_exit;
    }

    if(DropEmpTempTable() != SUCCESS)
    {
        goto fail_exit;
    }

    EXEC SQL COMMIT WORK RELEASE;
    if(sqlca.sqlcode != 0)
    {
        PRINT_SQL_ERROR("[ERROR] SQL ERROR -");
        goto fail_exit;
    }

    printf("SUCCESS\n");
    printf("#####\n");

    return 0;

fail_exit:

    printf("FAILURE\n");
    printf("#####\n\n");
    EXEC SQL ROLLBACK WORK RELEASE;

    return 0;
}

int Connect(sql_context aCtx, char *aHostInfo, char *aUserID, char *sPassword)
{
    EXEC SQL BEGIN DECLARE SECTION;
    VARCHAR  sUid[80];
    VARCHAR  sPwd[20];
    VARCHAR  sConnStr[1024];
    EXEC SQL END DECLARE SECTION;
    struct sqlca sqlca;

```

- Log on GOLDILOCKS

```
strcpy((char *)sUid.arr, aUserID);
    sUid.len = (short)strlen((char *)sUid.arr);
    strcpy((char *)sPwd.arr, sPassword);
    sPwd.len = (short)strlen((char *)sPwd.arr);
    strcpy((char *)sConnStr.arr, aHostInfo);
    sConnStr.len = (short)strlen((char *)sConnStr.arr);
```

- DB connection

```
if( aCtx != NULL )
    {
        EXEC SQL CONTEXT USE :aCtx;
        EXEC SQL CONNECT :sUid IDENTIFIED BY :sPwd USING :sConnStr;
    }
else
    {
        EXEC SQL CONTEXT USE DEFAULT;
        EXEC SQL CONNECT :sUid IDENTIFIED BY :sPwd USING :sConnStr;
    }
if(sqlca.sqlcode != 0)
    {
        goto fail_exit;
    }

return SUCCESS;

fail_exit:

    PRINT_SQL_ERROR("[ERROR] Connection Failure!");

return FAILURE;
}

int Disconnect(sql_context aCtx)
{
    struct sqlca sqlca;
```

- DB disconnection

```
if( aCtx != NULL )
    {
```



```

        EXEC SQL CONTEXT USE :aCtx;
        EXEC SQL DISCONNECT;
    }
else
{
    EXEC SQL CONTEXT USE DEFAULT;
    EXEC SQL DISCONNECT;
}
if(sqlca.sqlcode != 0)
{
    goto fail_exit;
}

return SUCCESS;

fail_exit:

    PRINT_SQL_ERROR("[ERROR] Connection Failure!");

return FAILURE;
}

```

- Create table

```

int CreateEmpTempTable()
{
    EXEC SQL DROP TABLE IF EXISTS EMP_TEMP;
    if(sqlca.sqlcode != 0)
    {
        goto fail_exit;
    }

    EXEC SQL
        CREATE TABLE EMP_TEMP (
            EMPNO NUMBER(4) CONSTRAINT PK_EMP_TEMP PRIMARY KEY,
            ENAME VARCHAR2(10),
            JOB VARCHAR2(9),
            SAL NUMBER(7,2),
            DEPTNO NUMBER(2) );
    if(sqlca.sqlcode != 0)
    {

```

```
        goto fail_exit;
    }

    EXEC SQL COMMIT WORK;
    if(sqlca.sqlcode != 0)
    {
        goto fail_exit;
    }
    return SUCCESS;

fail_exit:

    PRINT_SQL_ERROR("[ERROR] SQL ERROR -");
    EXEC SQL ROLLBACK WORK;

    return FAILURE;
}
```

- Drop table

```
int DropEmpTempTable()
{
    EXEC SQL DROP TABLE EMP_TEMP;
    if(sqlca.sqlcode != 0)
    {
        goto fail_exit;
    }

    EXEC SQL COMMIT WORK;
    if(sqlca.sqlcode != 0)
    {
        goto fail_exit;
    }

    return SUCCESS;

fail_exit:

    PRINT_SQL_ERROR("[ERROR] SQL ERROR -");
    EXEC SQL ROLLBACK WORK;
```

```
    return FAILURE;
}

void *clientThread(void *args)
{
    EXEC SQL BEGIN DECLARE SECTION;
    SQL_CONTEXT    my_context;
    char           job_name[20 + 1];
    EXEC SQL END DECLARE SECTION;
    int            state = 0;
    thread_param *param = (thread_param *)args;

    EXEC SQL CONTEXT ALLOCATE :my_context;
    state = 1;

    EXEC SQL CONTEXT USE :my_context;
    if(Connect(my_context, "DSN=GOLDILOCKS", "test", "test") != SUCCESS)
    {
        goto fail_exit;
    }
    state = 2;

    strcpy( job_name, param->mJobName );

    EXEC SQL
        INSERT INTO EMP_TEMP
        SELECT *
        FROM    EMP
        WHERE   JOB = :job_name;
    if(sqlca.sqlcode != 0)
    {
        goto fail_exit;
    }

    EXEC SQL COMMIT WORK;
    if(sqlca.sqlcode != 0)
    {
        goto fail_exit;
    }
    state = 1;
    if(Disconnect(my_context) != SUCCESS)
```

```

    {
        goto fail_exit;
    }
    state = 0;
    EXEC SQL CONTEXT FREE :my_context;
    pthread_exit(0);
    return NULL;

fail_exit:

    PRINT_SQL_ERROR("[ERROR] SQL ERROR -");
    switch(state)
    {
        case 2:
            (void)Disconnect(my_context);
        case 1:
            EXEC SQL CONTEXT FREE :my_context;
            break;
        default:
            break;
    }

    pthread_exit(0);
    return NULL;
}

```

### Host Structure

The C structure can be used as a host variable in an embedded SQL of GOLDILOCKS. A typical scalar variable represents a single column, but using the structure enables to simply express multiple column sets.

Host structure can only be used only in INTO clause of SELECT INTO or FETCH INTO statement and in VALUES clause of INSERT statement, but it can not be used in WHERE clause or UPDATE SET clause, because it has the same effect as when listing its member variables in sequence.

The structure is defined in the declare section to use the host structure, and it can be used as a host variable after declaring the structure variable. The structure is defined in the same way as defining the C struct, and it can also be used after defining the type via typedef.

The following is an example of using the host structure.

```

/*
 * sample4.gc

```

```

*
*/
#include <stdio.h>
#include <stdlib.h>
#include <string.h>

EXEC SQL INCLUDE SQLCA;

#define SUCCESS 0
#define FAILURE -1
#define PRINT_SQL_ERROR(aMsg) \
    { \
        printf("\n"); \
        printf(aMsg); \
        printf("\nSQLCODE : %d\nSQLSTATE : %s\nERROR MSG : %s\n", \
            sqlca.sqlcode, \
            SQLSTATE, \
            sqlca.sqlerrm.sqlerrmc ); \
    }

EXEC SQL BEGIN DECLARE SECTION;
typedef struct rsRecord
{
    int          mEmpNo;
    varchar      mENAME[20 + 1];
    char         mJob[20 + 1];
    long         mSalary;
} rsRecord;
EXEC SQL END DECLARE SECTION;

int Connect(char *aHostInfo, char *aUserID, char *sPassword);

int main(int argc, char **argv)
{
    EXEC SQL BEGIN DECLARE SECTION;
    rsRecord    sRecord;
    EXEC SQL END DECLARE SECTION;
    int sRecordCount = 0;

    printf("Connect GOLDILOCKS ...\n");
    if(Connect("DSN=GOLDILOCKS", "test", "test") != SUCCESS)
    {

```

```

        goto fail_exit;
    }

```

- Retrieve employee

EXEC SQL

```

    DECLARE EMP_CUR CURSOR FOR
    SELECT empno, ename, job, sal
    FROM EMP
    ORDER BY EMPNO;

EXEC SQL OPEN EMP_CUR;
if(sqlca.sqlcode != 0)
{
    PRINT_SQL_ERROR("[ERROR] SQL ERROR -");
    goto fail_exit;
}

printf(" EMPNO      ENAME                      JOB      SALARY\n");
printf("===== \n");
while( 1 )
{
    EXEC SQL
        FETCH EMP_CUR
        INTO :sRecord;
    if(sqlca.sqlcode == SQL_NO_DATA)
    {
        break;
    }
    else if(sqlca.sqlcode != 0)
    {
        PRINT_SQL_ERROR("[ERROR] SQL ERROR -");
        goto fail_exit;
    }

    sRecordCount ++;

    printf("%6d %20s %10s %8ld\n",
        sRecord.mEmpNo, sRecord.mENAME.arr, sRecord.mJob, sRecord.mSalary);
}

```

```

printf("=====  

printf("Record Count = %d\n", sRecordCount);  

printf("=====  

EXEC SQL CLOSE EMP_CUR;  

if(sqlca.sqlcode != 0)  

{  

    PRINT_SQL_ERROR("[ERROR] SQL ERROR -");  

    goto fail_exit;  

}  

EXEC SQL COMMIT WORK RELEASE;  

if(sqlca.sqlcode != 0)  

{  

    PRINT_SQL_ERROR("[ERROR] SQL ERROR -");  

    goto fail_exit;  

}  

printf("\n\nSUCCESS\n");  

printf("#####\n");  

return 0;  

fail_exit:  

printf("\n\nFAILURE\n");  

printf("#####\n\n");  

EXEC SQL ROLLBACK WORK RELEASE;  

return 0;  

}  

int Connect(char *aHostInfo, char *aUserID, char *sPassword)  

{  

    EXEC SQL BEGIN DECLARE SECTION;  

    VARCHAR sUid[80];  

    VARCHAR sPwd[20];  

    VARCHAR sConnStr[1024];  

    EXEC SQL END DECLARE SECTION;

```

- Log on GOLDILOCKS

```
strcpy((char *)sUId.arr, aUserID);
    sUId.len = (short)strlen((char *)sUId.arr);
    strcpy((char *)sPwD.arr, sPassword);
    sPwD.len = (short)strlen((char *)sPwD.arr);
    strcpy((char *)sConnStr.arr, aHostInfo);
    sConnStr.len = (short)strlen((char *)sConnStr.arr);
```

- DB connection

```
EXEC SQL CONNECT :sUId IDENTIFIED BY :sPwD USING :sConnStr;
    if(sqlca.sqlcode != 0)
    {
        goto fail_exit;
    }

    return SUCCESS;

fail_exit:
    PRINT_SQL_ERROR("[ERROR] Connection Failure!");

    return FAILURE;
}
```

When a user declares a structure for using the host variable, the restriction is as follows. The nested structure is not allowed. If another structure exists within the structure declaration as shown below, it can not be used as the host variable.

```
EXEC SQL BEGIN DECLARE SECTION;
typedef struct rsRecord
{
    struct person {
        int          mEmpNo;
        varchar      mENAME[20 + 1];
    } person;
    char            mJob[20 + 1];
    long            mSalary;
} rsRecord;
EXEC SQL END DECLARE SECTION;
```



## Indicator Variable

### Scalar Indicator

Host variables can be used together with the indicator variables combined with it. An indicator variable determines whether the current value of the host variable is NULL. The indicator variable is declared in the same way as the host variable, and it is declared only as an integer type of C (short, int, long, long long). Indicator is used as follows.

```
:hostvar INDICATOR :hostind
:hostvar :hostind (INDICATOR keyword can be omitted.)
```

The value of indicator variable means the followings.

**Table 33-9** Value of input indicator

Value	Meaning
-1	NULL
>= 0	It inputs a host variable value.

**Table 33-10** Value of output indicator

Value	Meaning
-1	NULL
0	All values are stored in a host variable.
> 0	It is the length of DB data when all values are not stored in a host variable due to an insufficient buffer size of host variable.

The following is an example of using the indicator.

```
/*
 * sample5.gc
 *
 */
#include <stdio.h>
#include <stdlib.h>
#include <string.h>

EXEC SQL INCLUDE SQLCA;

#define SUCCESS 0
#define FAILURE -1
#define PRINT_SQL_ERROR(aMsg) \
{ \
```

```

        printf("\n");
        printf(aMsg);
        printf("\nSQLCODE : %d\nSQLSTATE : %s\nERROR MSG : %s\n",
                sqlca.sqlcode,
                SQLSTATE,
                sqlca.sqlerrm.sqlerrmc );
    }

int Connect(char *aHostInfo, char *aUserID, char *sPassword);
int CreateEmpTempTable();
int DropEmpTempTable();

int main(int argc, char **argv)
{
    EXEC SQL BEGIN DECLARE SECTION;
    int          sEmpNo;
    varchar      sENAME[20 + 1];
    char         sJob[20];
    long         sSalary;
    int          sDeptNo;
    int          sDeptNoInd;
    EXEC SQL END DECLARE SECTION;
    int          sRecordCount = 0;
    int          state = 0;

    printf("Connect GOLDILOCKS ...\n");
    if(Connect("DSN=GOLDILOCKS", "test", "test") != SUCCESS)
    {
        goto fail_exit;
    }

    if(CreateEmpTempTable() != SUCCESS)
    {
        goto fail_exit;
    }
    state = 1;

```

- Update Dept NULL where deptno = 10

```

EXEC SQL
    UPDATE EMP_TEMP

```

```

        SET     DEPTNO = NULL
        WHERE  DEPTNO = 10;
if(sqlca.sqlcode != 0)
{
    PRINT_SQL_ERROR("[ERROR] SQL ERROR -");
    goto fail_exit;
}

```

- Retrieve employee

EXEC SQL

```

        DECLARE EMP_CUR CURSOR FOR
        SELECT empno, ename, job, sal, deptno
        FROM   EMP_TEMP
        ORDER BY empno;

EXEC SQL OPEN EMP_CUR;
if(sqlca.sqlcode != 0)
{
    PRINT_SQL_ERROR("[ERROR] SQL ERROR -");
    goto fail_exit;
}

printf(" EMPNO          ENAME          JOB          SALARY  DEPTNO\n");
printf("===== \n");
while( 1 )
{
    EXEC SQL
        FETCH EMP_CUR
        INTO  :sEmpNo, :sENAME, :sJob, :sSalary, :sDeptNo :sDeptNoInd;
    if(sqlca.sqlcode == SQL_NO_DATA)
    {
        break;
    }
    else if(sqlca.sqlcode != 0)
    {
        PRINT_SQL_ERROR("[ERROR] SQL ERROR -");
        goto fail_exit;
    }

    sRecordCount ++;
}

```

```
    if(sDeptNoInd == -1)
    {
        printf("%6d %20s %10s %8ld (null)\n",
            sEmpNo, sENAME.arr, sJob, sSalary);
    }
    else
    {
        printf("%6d %20s %10s %8ld %4d\n",
            sEmpNo, sENAME.arr, sJob, sSalary, sDeptNo);
    }
}

printf("=====  
printf("Record Count = %d\n", sRecordCount);  
printf("=====  
EXEC SQL CLOSE EMP_CUR;  
if(sqlca.sqlcode != 0)  
{  
    PRINT_SQL_ERROR("[ERROR] SQL ERROR -");  
    goto fail_exit;  
}  
  
state = 0;  
if(DropEmpTempTable() != SUCCESS)  
{  
    goto fail_exit;  
}  
  
EXEC SQL COMMIT WORK RELEASE;  
if(sqlca.sqlcode != 0)  
{  
    PRINT_SQL_ERROR("[ERROR] SQL ERROR -");  
    goto fail_exit;  
}  
  
printf("\n\nSUCCESS\n");  
printf("#####\n");  
  
return 0;
```

```

fail_exit:

    printf("\n\nFAILURE\n");
    printf("#####\n\n");

    switch( state )
    {
        case 1:
            (void)DropEmpTempTable();
            break;
        default:
            break;
    }

    EXEC SQL ROLLBACK WORK RELEASE;

    return 0;
}

int Connect(char *aHostInfo, char *aUserID, char *sPassword)
{
    EXEC SQL BEGIN DECLARE SECTION;
    VARCHAR   sUid[80];
    VARCHAR   sPwd[20];
    VARCHAR   sConnStr[1024];
    EXEC SQL END DECLARE SECTION;

```

- Log on GOLDILOCKS

```

strcpy((char *)sUid.arr, aUserID);
    sUid.len = (short)strlen((char *)sUid.arr);
    strcpy((char *)sPwd.arr, sPassword);
    sPwd.len = (short)strlen((char *)sPwd.arr);
    strcpy((char *)sConnStr.arr, aHostInfo);
    sConnStr.len = (short)strlen((char *)sConnStr.arr);

```

- DB connection

```

EXEC SQL CONNECT :sUid IDENTIFIED BY :sPwd USING :sConnStr;
    if(sqlca.sqlcode != 0)
    {
        goto fail_exit;
    }

```

```
    }  
  
    return SUCCESS;  
  
fail_exit:  
  
    PRINT_SQL_ERROR("[ERROR] Connection Failure!");  
  
    return FAILURE;  
}
```

- Create table

```
int CreateEmpTempTable()  
{  
    EXEC SQL DROP TABLE IF EXISTS EMP_TEMP;  
    if(sqlca.sqlcode != 0)  
    {  
        goto fail_exit;  
    }  
  
    EXEC SQL  
        CREATE TABLE EMP_TEMP (  
            EMPNO NUMBER(4) CONSTRAINT PK_EMP_TEMP PRIMARY KEY,  
            ENAME VARCHAR2(10),  
            JOB VARCHAR2(9),  
            SAL NUMBER(7,2),  
            DEPTNO NUMBER(2) );  
    if(sqlca.sqlcode != 0)  
    {  
        goto fail_exit;  
    }  
  
    EXEC SQL  
        INSERT INTO EMP_TEMP  
        SELECT * FROM EMP;  
    if(sqlca.sqlcode != 0)  
    {  
        goto fail_exit;  
    }  
}
```

```
EXEC SQL COMMIT WORK;
if(sqlca.sqlcode != 0)
{
    goto fail_exit;
}

return SUCCESS;

fail_exit:

PRINT_SQL_ERROR("[ERROR] SQL ERROR -");

EXEC SQL ROLLBACK WORK;

return FAILURE;
}
```

- Drop table

```
int DropEmpTempTable()
{
    EXEC SQL DROP TABLE EMP_TEMP;
    if(sqlca.sqlcode != 0)
    {
        goto fail_exit;
    }

    EXEC SQL COMMIT WORK;
    if(sqlca.sqlcode != 0)
    {
        goto fail_exit;
    }

    return SUCCESS;

fail_exit:

PRINT_SQL_ERROR("[ERROR] SQL ERROR -");
EXEC SQL ROLLBACK WORK;

return FAILURE;
}
```

```
}

```

## Structure Indicator

If a host variable is a scalar variable, an Indicator variable is declared and combined with the host variable, then it is used. If the host variable is the structure, each variable configuring the structure can not be used with an indicator variable. In this case, the indicator should also be the structure.

When declaring an indicator structure, it should comply with the followings.

- The number of indicator members should be as same as the number of host variable structure members to be combined.
- All members of the indicator structure should have the integer data type.

For example, if the following structure is declared, the member of indicator structure should be four because the number of the variables of the structure is four.

```
EXEC SQL BEGIN DECLARE SECTION;
typedef struct rsRecord
{
    int          mEmpNo;
    varchar      mENAME[20 + 1];
    char         mJob[20 + 1];
    long         mSalary;
} rsRecord;
EXEC SQL END DECLARE SECTION;
```

Therefore, it should be declared as follows.

```
EXEC SQL BEGIN DECLARE SECTION;
typedef struct rsRecordInd
{
    int          mEmpNoInd;
    int          mENAMEInd;
    int          mJobInd;
    int          mSalaryInd;
} rsRecordInd;
EXEC SQL END DECLARE SECTION;
```

Each indicator structure member sequentially corresponds one-to-one to the host variable structure member which is combined to the indicator structure. When declaring as above, the combination relationship is as follows.



:rsRecordVar INDICATOR :rsRecordIndVar

Host variable	Indicator to be combined
rsRecordVar.mEmpNo	rsRecordIndVar.mEmpNoInd
rsRecordVar.mENAME	rsRecordIndVar.mENAMEInd
rsRecordVar.mJob	rsRecordIndVar.mJobInd
rsRecordVar.mSalary	rsRecordIndVar.mSalaryInd

## Embedded SQL

### Host Variable

The host variable is used as the data input/output medium between the application and GOLDILOCKS. The input host variable transfers the data from the application to GOLDILOCKS, and the output host variable transfers the data from GOLDILOCKS to the application. The declarations of two variables are same and their roles are determined in the SQL statement in use.

The host variable which is located in INTO clause of SELECT or FETCH statement is the output host variable received the data from GOLDILOCKS. Other than that is the input host variable. The input host variable should be set before executing the SQL statement.

### Host Indicator

The host variable literally uses the variable of C language, so a particular way to display NULL does not exist. The indicator variable can be used for that, and a single indicator is combined with a single host variable.

An indicator variable means the followings.

**Table 33-11** Value of input indicator

Value	Meaning
-1	NULL
>= 0	It inputs a host variable value.

**Table 33-12** Value of output indicator

Value	Meaning
-1	NULL
0	All values are stored in a host variable.
> 0	It is the length of DB data when all values are not stored in a host variable due to an insufficient buffer size of host variable.

## Insert NULL

NULL is inserted in a column as follows.

```
EXEC SQL INSERT INTO EMP ( EMPNO, DEPTNO ) VALUES ( :empno, NULL );
```

However, if hard coding above is used to create the application, the flexibility becomes very poor. The following is an example of using the indicator variable.

```
deptno_ind = -1;
EXEC SQL INSERT INTO EMP ( EMPNO, DEPTNO ) VALUES ( :empno, :deptno :deptno_ind );
```

If the value of deptno\_ind which is the indicator variable is -1, it is recognized as NULL regardless of the value of deptno which is the host variable.

## Fetch NULL

When GOLDILOCKS receives the data, the indicator variable can be used to determine whether to be NULL. The following is an example.

```
EXEC SQL DECLARE CUR_1 CURSOR FOR
    SELECT  EMPNO, DEPTNO
    FROM    EMP
    WHERE   EMPNO = :emp_number;
EXEC SQL OPEN CUR_1;

while( 1 )
{
    EXEC SQL FETCH CUR_1 INTO :empno, :deptno :deptno_ind;
    if( sqlca.sqlcode == SQL_NO_DATA )
    {
        break;
    }

    if( deptno_ind == -1 )
    {
        printf( "empno : %d, deptno : (null)\n", empno );
    }
    else
    {
        printf( "empno : %d, deptno : %d\n", empno, deptno );
    }
}
```

```
EXEC SQL CLOSE CUR_1;
```

If deptno\_ind is -1 after performing FETCH, it determines that deptno is NULL.

## Basic SQL Statement

All SQL statements provided in GOLDILOCKS is available in an embedded SQL. For more information about SQL statements, refer to **Part III. SQL Manual**. When using an SQL statement in an embedded SQL, the SQL statement is specified after EXEC SQL keyword. This chapter describes Data Definition Language (DDL) or Data Manipulation Language (DML), and the next chapter describes the statements repeatedly retrieving data as like a query.

SQLCA is checked to determine whether the SQL statement is successfully executed. For more information, refer to **Handling Run-time Errors**.

## DDL Statement

DDL statement is an SQL statement which creates, drops or alters GOLDILOCKS objects such as table, view, index. When executing a DDL statement in an embedded SQL application, the SQL statement is specified after EXEC SQL keyword.

```
EXEC SQL DROP TABLE IF EXISTS EMP;
EXEC SQL
    CREATE TABLE EMP (
        EMPNO NUMBER(4) CONSTRAINT PK_EMP PRIMARY KEY,
        ENAME VARCHAR2(10),
        JOB VARCHAR2(9),
        SAL NUMBER(7,2),
        DEPTNO NUMBER(2) );
```

The host variable can not be used in DDL statement. Therefore, the following usage is wrong.

```
strcpy( table_name, "T1" );
EXEC SQL CREATE TABLE :table_name ( C1 INTEGER );
```

If DDL statement is to be used variably as above because the DDL statement is not defined while creating the application, the dynamic SQL statement can be used as follows.

```
strcpy( table_name, "T1" );
sprintf( sql_stmt, "CREATE TABLE %s ( C1 INTEGER )", table_name );
EXEC SQL EXECUTE IMMEDIATE :sql_stmt;
```

For more information, refer to **Embedded Dynamic SQL**.

## Select Into Statement

The query is used to retrieve the data from GOLDILOCKS. Generally, the number of retrieved rows are not known, so the cursor object is declared and the process of open, fetch, close may be performed to use the query statement. For more information, refer to **Cursor**.

However, the number of retrieved rows are known in a special case. For example, when the primary key is known and the record with the same primary key is retrieved, then it can be predicted that the result either does not exist or has up to one record. The select into statement is used when the number of the result records is less than one as follows.

```
EXEC SQL
  SELECT ename, job, sal
  INTO :emp_name, :job_title, :salary
  FROM emp
  WHERE empno = :emp_number;
```



Several records can be retrieved by using select into statement when using host array. For more information about host array, refer to **Host Array**.

## Insert Statement

The insert statement is used to insert rows into a table. The column value can be determined by using the host variable, and NULL can be inserted by using an indicator.

The following is an example of the insert statement.

```
EXEC SQL
  INSERT INTO EMP ( empno, ename, job, sal )
  VALUES ( :emp_number, :emp_name, :job_name :job_ind, :saraly );
EXEC SQL
  INSERT INTO DEPT ( deptno, dname, loc )
  VALUES ( 1, :dept_name, NULL );
```



When using host structure, data can be inserted in structure units instead of individually using host variable.

```
EXEC SQL BEGIN DECLARE SECTION;
typedef struct rsRecord
```

```

{
    int          mEmpNo;
    varchar      mENAME[20 + 1];
    char         mJob[20 + 1];
    long         mSalary;
} rsRecord;

rsRecord sInsertRec;
EXEC SQL END DECLARE SECTION;

sInsertRec.mEmpNo = 3000;
strcpy( sInsertRec.mENAME.arr, "John" );
sInsertRec.mENAME.len = strlen( sInsertRec.mENAME.arr );
strcpy( sInsertRec.mJob , "RND" );
sInsertRec.mSalary = 3500;

EXEC SQL INSERT INTO EMP ( empno, ename, job, sal ) VALUES ( :sInsertRec );

```



Multiple rows can be inserted by using host array at once. For more information, refer to **Host Array**.

## Update Statement

The update statement is used to update the column values of the specific rows in a table. The column value can be determined by using the host variable, and NULL can be inserted by using an indicator. The following is an example of the update statement.

```

EXEC SQL
    UPDATE emp
    SET sal = :salary, deptno = :dept_number :deptno_ind
    WHERE empno = :emp_number;

```



Multiple rows can be updated by using host array at once. For more information, refer to **Host Array**.

## Delete Statement

The delete statement removes the specific rows from a table. The following is an example of the delete statement.

```
EXEC SQL
```

```
DELETE FROM emp
WHERE empno = :emp_number;
```



Multiple rows can be deleted by using host array at once. For more information, refer to **Host Array**.

## PSM Statement

PSM statement creates a procedure or a function within a server and uses it. For more information about PSM, refer to **PSM manual**.

Generally, it starts with EXEC SQL EXECUTE and ends with END-EXEC;. However, when creating a procedure or a function, EXEC SQL is used instead of EXEC SQL EXECUTE.

The following is an example of a statement creating and calling a procedure.

```
EXEC SQL
```

```
CREATE OR REPLACE PROCEDURE PROC1( A1 INTEGER, A2 INTEGER )
IS
  V1 INTEGER;
BEGIN
  SELECT COUNT(*)
  INTO V1
  FROM T1
  WHERE T1.I1 >= A1 AND T1.I1 <= A2;
  DBMS_OUTPUT.PUT_LINE( 'V1 = ' || V1 );
END;
END-EXEC;
EXEC SQL CALL PROC1( 2, 4 );
```

The following is an example of a statement creating and calling a function.

```
EXEC SQL BEGIN DECLARE SECTION;
```

```
  int          sV1 = 0;
```

```
EXEC SQL END DECLARE SECTION;
```

```
EXEC SQL
```

```
CREATE OR REPLACE FUNCTION FUNC1( A1 INTEGER, A2 INTEGER )
RETURN INTEGER
IS
  V1 INTEGER;
```

```

BEGIN
  SELECT COUNT(*)
    INTO V1
    FROM T1
    WHERE T1.I1 >= A1 AND T1.I1 <= A2;
  RETURN V1;
END;
END-EXEC;
EXEC SQL CALL FUNC1( 2, 4 ) INTO :sV1;

```

The following is an example of an anonymous block statement.

```

EXEC SQL EXECUTE
  DECLARE
    V1 INTEGER := 0;
    FUNCTION FUNC1( A1 INTEGER )
      RETURN INTEGER
    IS
      BEGIN
        RETURN A1 * 10;
      END;
  BEGIN
    V1 := FUNC1( 10 );
    DBMS_OUTPUT.PUT_LINE( 'V1 = ' || V1 );
  END;
END-EXEC;

```

```

EXEC SQL EXECUTE
  DECLARE
    PROCEDURE PROC1( A1 INTEGER )
    IS
      BEGIN
        DBMS_OUTPUT.PUT_LINE( 'A1 = ' || A1 );
      END;
  BEGIN
    PROC1( 100 );
  END;
END-EXEC;

```

## Cursor

The application executes the query to retrieve data from GOLDILOCKS. Generally, the cursor is used because the number of rows retrieved are not known when executing the query. The cursor is an identifier which specifies the position of the current row in the query result set. The cursor can be manipulated via the following operations.

### Declare Cursor

It declares a cursor. The cursor name and its query should be specified. The declared cursor name is used for different cursor manipulation commands later.

The following is an example of the cursor declaration.

```
EXEC SQL
    DECLARE RECORD_CUR1 CURSOR FOR
    SELECT empno, ename, dept
    FROM SEMP
    ORDER BY empno;
```

The cursor name is an identifier recognized and used by the precompiler, and it has nothing to do with the variable of C program. The scope of the cursor is a file. Therefore, even when the cursor with the same name is defined in another file, it is considered as a separate cursor. In other words, all statements which perform the operations such as declare/ open/ fetch/ close of the cursor should exist on a single source file.

### Open Cursor

It opens a cursor.

```
EXEC SQL OPEN <cursor_name>;
Example)
EXEC SQL OPEN EMP_CURSOR;
```

If the cursor is opened, it is prepared to fetch the result set which the query of the declared cursor is executed. However, it does not actually fetch the result. **Fetch Cursor** should be performed to actually fetch the data.

The host variable which is used when executing the query does not affect the result set until the current cursor is closed.

```
EXEC SQL DECLARE EMP_CURSOR CURSOR FOR
    SELECT empno, ename, dept
    FROM EMP
    WHERE empno < :sNo
```



```

        ORDER BY empno;

sNo = 100;
EXEC SQL OPEN EMP_CURSOR;
if(sqlca.sqlcode != 0)
{
    goto fail_exit;
}

while( 1 )
{
    sNo = 10;
    EXEC SQL FETCH EMP_CURSOR INTO :emp_number, :emp_name, :dept_name;
    if(sqlca.sqlcode == SQL_NO_DATA)
    {
        break;
    }
    else if(sqlca.sqlcode != 0)
    {
        goto fail_exit;
    }
    ...
}

```

In the example above, even if the cursor is opened with `sNo = 100` and `sNo` is changed during the processing, it does not affect the result set until the cursor is closed.

## Fetch Cursor

It fetches the row at the cursor position.

```
EXEC SQL FETCH <cursor_name> INTO <host_variable_list>;
```

Example)

```
EXEC SQL FETCH EMP_CURSOR INTO :emp_number, :emp_name, :dept_name;
```

The cursor should be declared first for FETCH operation, and it should be open. If FETCH is performed for the first time, the cursor moves to the first row of the result set and specifies it as a current row. Then, it fetches the current row into the host variable of INTO clause and returns. After then, if FETCH is repeatedly performed, the cursor updates the current row to the next row, and then it repeatedly fetches the current row into the host variable of INTO clause and returns. If the result does not exist even after performing FETCH, `SQL_NO_DATA` code is returned in `sqlca.sqlcode`, and the application checks this code to determine whether this operation is terminated.

## Close Cursor

It closes a cursor.

```
EXEC SQL CLOSE <cursor_name>;
```

Example)

```
EXEC SQL CLOSE EMP_CURSOR;
```

The cursor should already be open to close it. The FETCH can not be performed in this cursor after closing the cursor. If the cursor is opened to use it again after it is close, then it becomes a new cursor. Therefore, the result set of the new cursor may be different from the result set of the previously closed cursor.

## Reusing Cursor

The cursor name which was already declared is repeatedly reusable. This paragraph describes the sequence to reuse the same cursor name.

## Sequence of Cursor Statement

- DECLARE CURSOR  
It can be performed after performing cursor CLOSE, COMMIT and ROLLBACK statements.
- OPEN  
It can be performed when the cursor is completely fetched or after performing CLOSE statement.
- FETCH  
It can be performed after performing cursor OPEN statement.
- CLOSE  
It can be performed after performing cursor OPEN statement or FETCH statement.

## Cursor Statement and Host Variable

Cursor statement can be located in any place within a file. However, the usage of the cursor statement varies depending on whether the input host variable used in DECLARE statement is a global variable or a local variable.

- If the input host variable used in DECLARE statement is a local variable, then OPEN statement should be located in the function where DECLARE statement is located.
- If the input host variable used in DECLARE statement is a global variable, then OPEN statement can be located in the function which is different from where DECLARE statement is located.
- If the input host variable does not exist in DECLARE statement, then OPEN statement can be located in the function which is different from where DECLARE statement is located.

The reason is that the pointer of the host variable used in cursor declare statement is implicitly stored, and the pointer is used in cursor open statement, so if two statements are located in different functions and

used host variables are local variables, then open statement refers to the invalid pointer. Therefore, it is recommended to locate both declare statement and open statement within the same function.

## Example of Using Cursor

The following is an example of using DDL, DML and cursor.

```

/*
 * overview.gc
 *
 * Connect / Disconnect
 * DDL(Create/Drop table)
 * Basic DML(Insert, Delete, Update)
 * Standing Cursor
 */
EXEC SQL INCLUDE SQLCA;

#include <stdio.h>
#include <stdlib.h>
#include <string.h>

#define SUCCESS 0
#define FAILURE -1
#define PRINT_SQL_ERROR(aMsg) \
    { \
        printf("\n"); \
        printf(aMsg); \
        printf("\nSQLCODE : %d\nSQLSTATE : %s\nERROR MSG : %s\n", \
            sqlca.sqlcode, \
            SQLSTATE, \
            sqlca.sqlerrm.sqlerrmc ); \
    }

EXEC SQL BEGIN DECLARE SECTION;
typedef struct rsEmpRecord
{
    int      mEmpNo;
    char     mENAME[20];
    char     mDept[10];
} rsEmpRecord;

```

```
rsEmpRecord gRecord[10] = {
    { 1, "Park", "RND" },
    { 2, "Kim", "CEO" },
    { 3, "Choi", "SALES" },
    { 4, "Lee", "CTO" },
    { 5, "Lyu", "RND" },
    { 6, "Ohn", "SUPPORT" },
    { 7, "Cheon", "RND" },
    { 8, "Sohn", "SALES" },
    { 9, "Smith", "WAIT" },
    { 10, "mycomman", "WAIT" }
};
EXEC SQL END DECLARE SECTION;

int CreateEmpTable();
int DropEmpTable();
int Connect(char *aHostInfo, char *aUserID, char *sPassword);
int Disconnect();
int PrintRecord();

int main(int argc, char **argv)
{
    EXEC SQL BEGIN DECLARE SECTION;
    int      sEmpNo;
    char     sDept[10 + 1];
    EXEC SQL END DECLARE SECTION;
    int  sState = 0;

    printf("Connect GOLDILOCKS ...\n");
    if(Connect("DSN=GOLDILOCKS", "test", "test") != SUCCESS)
    {
        goto fail_exit;
    }
    sState = 1;

    printf("Create SEMP table ...\n");
    if(CreateEmpTable() != SUCCESS)
    {
        goto fail_exit;
    }
    sState = 2;
```

```
printf("Insert record ...\n");
EXEC SQL
    INSERT INTO SEMP(empno, ename, dept)
    VALUES(:gRecord);
if(sqlca.sqlcode != 0)
{
    PRINT_SQL_ERROR("[ERROR] SQL ERROR -");
    goto fail_exit;
}
printf("=====\n");
printf("%d Record Inserted\n", sqlca.sqlerrd[2]);
printf("=====\n");

EXEC SQL COMMIT WORK;
if(sqlca.sqlcode != 0)
{
    PRINT_SQL_ERROR("[ERROR] SQL ERROR -");
    goto fail_exit;
}

printf("Current record\n");
PrintRecord();

sEmpNo = 9;
printf("Delete record WHERE empno == %d\n", sEmpNo);
EXEC SQL
    DELETE FROM SEMP
    WHERE empno = :sEmpNo;
if(sqlca.sqlcode != 0)
{
    PRINT_SQL_ERROR("[ERROR] SQL ERROR -");
    goto fail_exit;
}

printf("After Delete record\n");
PrintRecord();

EXEC SQL COMMIT WORK;
if(sqlca.sqlcode != 0)
{
```

```
        PRINT_SQL_ERROR("[ERROR] SQL ERROR -");
        goto fail_exit;
    }

strcpy( sDept, "RND" );
printf("Update record WHERE dept == 'WAIT'\n");
EXEC SQL
    UPDATE SEMP
    SET    dept = :sDept
    WHERE dept = 'WAIT';
if(sqlca.sqlcode != 0)
{
    PRINT_SQL_ERROR("[ERROR] SQL ERROR -");
    goto fail_exit;
}

printf("After Update record\n");
PrintRecord();

EXEC SQL COMMIT WORK;
if(sqlca.sqlcode != 0)
{
    PRINT_SQL_ERROR("[ERROR] SQL ERROR -");
    goto fail_exit;
}

sState = 1;
printf("Drop SEMP table ...\n");
if(DropEmpTable() != SUCCESS)
{
    goto fail_exit;
}

sState = 0;
printf("Disconnect GOLDILOCKS ...\n");
if(Disconnect() != SUCCESS)
{
    goto fail_exit;
}

printf("SUCCESS\n");
```

```

printf("#####\n");

return 0;

fail_exit:

printf("FAILURE\n");
printf("#####\n\n");

EXEC SQL ROLLBACK WORK;
switch(sState)
{
    case 2:
        printf("Drop SEMP table ...\n");
        (void)DropEmpTable();
    case 1:
        printf("Disconnect GOLDILOCKS ...\n");
        (void)Disconnect();
        break;
    default:
        break;
}

return 0;
}

```

- Create table

```

int CreateEmpTable()
{
    EXEC SQL DROP TABLE IF EXISTS SEMP;
    if(sqlca.sqlcode != 0)
    {
        goto fail_exit;
    }

    EXEC SQL CREATE TABLE SEMP ( empno          INTEGER,
                                ename          VARCHAR(20),
                                dept          VARCHAR(10),
                                PRIMARY KEY (empno) );

    if(sqlca.sqlcode != 0)

```

```
{
    goto fail_exit;
}

EXEC SQL COMMIT WORK;
if(sqlca.sqlcode != 0)
{
    goto fail_exit;
}

return SUCCESS;

fail_exit:

PRINT_SQL_ERROR("[ERROR] SQL ERROR -");

EXEC SQL ROLLBACK WORK;

return FAILURE;
}
```

- Drop table

```
int DropEmpTable()
{
    EXEC SQL DROP TABLE SEMP;
    if(sqlca.sqlcode != 0)
    {
        goto fail_exit;
    }

    EXEC SQL COMMIT WORK;
    if(sqlca.sqlcode != 0)
    {
        goto fail_exit;
    }

    return SUCCESS;

fail_exit:
```



```

    PRINT_SQL_ERROR("[ERROR] SQL ERROR -");

    EXEC SQL ROLLBACK WORK;

    return FAILURE;
}

int Connect(char *aHostInfo, char *aUserID, char *sPassword)
{
    EXEC SQL BEGIN DECLARE SECTION;
    VARCHAR sUId[80];
    VARCHAR sPwD[20];
    VARCHAR sConnStr[1024];
    EXEC SQL END DECLARE SECTION;

```

- Log on GOLDILOCKS

```

strcpy((char *)sUId.arr, aUserID);
    sUId.len = (short)strlen((char *)sUId.arr);
    strcpy((char *)sPwD.arr, sPassword);
    sPwD.len = (short)strlen((char *)sPwD.arr);
    strcpy((char *)sConnStr.arr, aHostInfo);
    sConnStr.len = (short)strlen((char *)sConnStr.arr);

```

- DB connection

```

EXEC SQL CONNECT :sUId IDENTIFIED BY :sPwD USING :sConnStr;
    if(sqlca.sqlcode != 0)
    {
        goto fail_exit;
    }

    return SUCCESS;

fail_exit:

    PRINT_SQL_ERROR("[ERROR] Connection Failure!");

    return FAILURE;
}

int Disconnect()

```

```
{
    EXEC SQL DISCONNECT;
    if(sqlca.sqlcode != 0)
    {
        goto fail_exit;
    }

    return SUCCESS;

fail_exit:

    PRINT_SQL_ERROR("[ERROR] [ERROR] Disconnect Failure!");

    return FAILURE;
}

int PrintRecord()
{
    EXEC SQL BEGIN DECLARE SECTION;
    rsEmpRecord sResultRecord;
    EXEC SQL END DECLARE SECTION;
    int sRecordCount = 0;

    EXEC SQL
        DECLARE RECORD_CUR1 CURSOR FOR
        SELECT empno, ename, dept
        FROM SEMP
        ORDER BY empno;

    EXEC SQL OPEN RECORD_CUR1;
    if(sqlca.sqlcode != 0)
    {
        goto fail_exit;
    }

    printf(" EMPNO      ENAME                DEPT\n");
    printf("===== \n");
    while( 1 )
    {
        EXEC SQL FETCH RECORD_CUR1 INTO :sResultRecord;
        if(sqlca.sqlcode == SQL_NO_DATA)
```

```

    {
        break;
    }
    else if(sqlca.sqlcode != 0)
    {
        goto fail_exit;
    }

    sRecordCount ++;

    printf("%6d %20s %10s\n",
           sResultRecord.mEmpNo,
           sResultRecord.mEName,
           sResultRecord.mDept);
}

printf("=====\n");
printf("Record Count = %d\n", sRecordCount);
printf("=====\n");

EXEC SQL CLOSE RECORD_CUR1;
if(sqlca.sqlcode != 0)
{
    goto fail_exit;
}

return SUCCESS;

fail_exit:

    PRINT_SQL_ERROR("[ERROR] SQL ERROR -");

return FAILURE;
}

```

## Cursor Property

The previous chapter described only the most basic cursor. However, the cursor may have various properties, and it can perform various functions depending on the properties. An embedded SQL of GOLDILOCKS provides the cursor properties provided in ISO/IEC-9075-2 SQL Foundation and ODBC.

For more information about the cursor definition syntax and the property, refer to **DECLARE cursor\_name**.

## Scrollable Cursor

SCROLL is the cursor property of ISO type, and it determines whether the cursor is scrollable. The scrollable cursor can receive the position option in the FETCH statement, and the row at the position according to this option is fetched. If scrolling is impossible, it can FETCH only the row in the result set sequentially.

When declaring the scroll cursor, SCROLL option is used. The following is an example of the declaration.

```
EXEC SQL DECLARE cur_scro11 SCROLL CURSOR FOR SELECT c1, c2 FROM t1;
```

With NO SCROLL option, the cursor which is unable to scroll is declared. When the scroll option is not given, the default value is NO SCROLL.

For the scrollable cursor, it is possible to specify the position information when fetching. This position information is called as fetch orientation, and it is as follows.

**Table 33-13** Fetch orientation

Fetch orientation	Description
NEXT	It fetches the next row of the current position.
PRIOR	It fetches the previous row of the current position.
FIRST	It fetches the first row in the result set.
LAST	It fetches the last row in the result set.
CURRENT	It fetches the row of the current position.
ABSOLUTE <position>	<ul style="list-style-type: none"> <li>It fetches the row corresponding to <i>position</i> in the result set.</li> <li>If the position value is a negative number, it fetches the row of the previous position from AFTER THE LAST ROW.</li> </ul>
RELATIVE <position>	It fetches the row which is away as much as <i>position</i> from the current position.

If fetch orientation is ABSOLUTE or RELATIVE, the value of <position> is additionally required. The value of <position> may be an integer literal or the host variable of the integer type. The following is an example of fetch orientation.

```
EXEC SQL FETCH NEXT;
EXEC SQL FETCH PRIOR;
EXEC SQL FETCH FIRST;
EXEC SQL FETCH LAST;
EXEC SQL FETCH CURRENT;
EXEC SQL FETCH ABSOLUTE 100;
EXEC SQL FETCH RELATIVE :position;
```

## Sensitive Cursor

Sensitivity is the cursor property of ISO type, and it determines whether the changes can be displayed if the result set is changed during the cursor operation. Sensitivity has the following three options.

**Table 33-14** Sensitivity

Option	Description
SENSITIVE	The information which is deleted or updated in another transaction can be viewed.
INSENSITIVE	The information which is deleted or updated after the cursor is opened can not be viewed.
ASENSITIVE	SENSITIVE/ INSENSITIVE is selected according to information of query.

If sensitive option is not specified, the default value is INSENSITIVE, and the cursor with the sensitive option is declared as follows.

```
EXEC SQL DECLARE <cur_name> SENSITIVE CURSOR FOR SELECT c1, c2 FROM t1;
EXEC SQL DECLARE <cur_name> INSENSITIVE CURSOR FOR SELECT c1, c2 FROM t1;
EXEC SQL DECLARE <cur_name> ASENSITIVE CURSOR FOR SELECT c1, c2 FROM t1;
```

## Holdable Cursor

Holdability is the cursor property of ISO type, and it determines whether the cursor is still held even after the transaction which opened the current cursor is committed. Holdability has the following two options.

**Table 33-15** Holdability

Option	Description
WITH HOLD	<ul style="list-style-type: none"> <li>The cursor is held even after the end of the transaction.</li> <li>It can not be used with FOR UPDATE clause.</li> <li>It can not be used with INSERT INTO ... RETURNING statement.</li> <li>It can not be used with UPDATE ... RETURNING statement.</li> <li>It can not be used with DELETE FROM ... RETURNING statement.</li> <li>It can not be used in the query including the global temporary table whose table commit action is ON COMMIT DELETE ROWS.</li> </ul>
WITHOUT HOLD	The cursor is closed when COMMIT/ ROLLBACK the transaction.
Rollback and cursor	<ul style="list-style-type: none"> <li>It closes a cursor which is included in a transaction when rolling back the transaction.</li> <li>It closes a cursor which is created after the savepoint when rolling back the transaction to the savepoint.</li> </ul>

If holdable option is not specified, the default value is determined according to <cursor updatability>.

- If FOR READ ONLY or <cursor updatability> is not specified, it is WITH HOLD.
- If it is used with FOR UPDATE statement, it is WITHOUT HOLD.

The cursor using holdable option is declared as follows.

```
EXEC SQL DECLARE <cur_name> CURSOR WITH HOLD FOR SELECT c1, c2 FROM t1;
EXEC SQL DECLARE <cur_name> CURSOR WITHOUT HOLD FOR SELECT c1, c2 FROM t1 FOR UPDATE;
```

## Static Cursor

Static cursor is the cursor property of ODBC type, and it is as same as INSENSITIVE SCROLL cursor of ISO type.

```
EXEC SQL DECLARE cur_static STATIC CURSOR FOR SELECT c1, c2 FROM t1;
```

For more information about how to fetch the static cursor, refer to **Scrollable Cursor**.

## Keyset Driven Cursor

Keyset driven cursor is the cursor property of ODBC type, it is as same as SENSITIVE SCROLL cursor of ISO type.

```
EXEC SQL DECLARE cur_static KEYSET CURSOR FOR SELECT c1, c2 FROM t1;
```

Keyset driven cursor also has the scroll feature, so for more information about how to fetch, refer to **Scrollable Cursor**.

## Positioned DML

Positioned DML refers that delete or update statement can be executed for the finally fetched row using CURRENT OF <cursor\_name> clause. The cursor should be open and point to the row by performing the Fetch at least once to execute the positioned DML.

The following is an example of executing the positioned DML.

```
EXEC SQL DECLARE emp_cursor CURSOR FOR
    SELECT ename, sal FROM emp WHERE job = 'SALES'
    FOR UPDATE;
...
EXEC SQL OPEN emp_cursor;
EXEC SQL WHENEVER NOT FOUND GOTO ...
while( 1 )
{
    EXEC SQL FETCH emp_cursor INTO :emp_name, :salary;
    ...
    EXEC SQL UPDATE emp SET sal = :new_salary
        WHERE CURRENT OF emp_cursor;
```

```
}
```

## Options

This chapter describes the applicable options when an embedded SQL source code is precompiled.

### Precompiled Header File

When developing the embedded SQL program, it is efficient that the information referenced in common by multiple source codes is stored in the separated header file and the header file is included in the source code. C language supports this feature by using `#include` statement. However, when the header file is included by using `#include` of C language the target file is not precompiled but it is interpreted by the compiler of C language, so the declare section within the file is not converted by the precompiler.

EXEC SQL INCLUDE statement is used to convert and insert this header file into the source code by the precompiler when creating the header file. The syntax is as follows.

```
EXEC SQL INCLUDE <filename>;
```

The statement above precompiles the given file and inserts it into the source code.

### Specifying Header File Path

Generally, it preferentially searches for the directory in which the current source code is stored when searching for the header file. However, header files are often separately stored in many cases or they exist in other paths for many reasons.

In this case, the directory searching for the header file is given separately as an option, and the syntax is as follows.

```
EXEC SQL OPTION( INCLUDE = <directory path> );
```

Several options can be listed and the directories are searched in the order given by the options when searching for the header file via EXEC SQL INCLUDE.



This option can be given via command-line option of precompiler. For more information, refer to `--include-path, -I` of **Precompiler Options**.

## Host Array

So far, only the scalar variables having only a single value as the host variable were described. This chapter describes how to use the array with the host variable.

When using the host array, the program source code becomes simple, and the performance is improved, but it should be used carefully because there are restrictions.

### Declaring Host Array

Declaration of the host array is as same as the declaration of the scalar variable. A variable is required only to be declared as an array itself. The following is an example of declaring the host array with its size 10.

```
EXEC SQL BEGIN DECLARE SECTION;
    int    empno[10];
    char   ename[10][20];
    double salary[10];
EXEC SQL END DECLARE SECTION;
```

The host array declaration has the following limitations.

- More than two-dimensional array is not allowed.
- Exceptionally, the string family (char, varchar) and binary family (binary, varbinary) can be used as the two-dimensional array because their array consists of an array subscript representing the array size and data size.
- An array of pointer is not allowed.

### Using Host Array

#### Accessing Host Array

How to use the host array in the SQL statement is as same as to use the scalar host variable.

The following is a simple example of the host array.

```
EXEC SQL BEGIN DECLARE SECTION;
int    emp_number[20];
char   emp_name[20][10];
int    dept_number[20];
EXEC SQL END DECLARE SECTION;
```

- Setting the values of emp\_number, emp\_name, dept\_number



...

- Inserting the values of emp\_number, emp\_name, dept\_number

```
EXEC SQL INSERT INTO emp (empno, ename, deptno)
VALUES (:emp_number, :emp_name, :dept_number);
```

The example above has the same feature as the following code.

```
EXEC SQL BEGIN DECLARE SECTION;
int    emp_number[20];
char   emp_name[20][10];
int    dept_number[20];
EXEC SQL END DECLARE SECTION;
```

- Setting the values of emp\_number, emp\_name, dept\_number

...

- Inserting the values of emp\_number, emp\_name, dept\_number

```
for( i = 0; i < 20; i ++ )
{
    EXEC SQL INSERT INTO emp (empno, ename, deptno)
        VALUES (:emp_number[i], :emp_name[i], :dept_number[i]);
}
```

When using several host variable arrays, the operation is performed for the array with the smallest array size among the host arrays. In the example above, 20 rows are inserted because the size of every host variable is 20. However, 10 rows are inserted as a result in the example below, if the array size of dept\_number is specified as 10.

```
EXEC SQL BEGIN DECLARE SECTION;
int    emp_number[20];
char   emp_name[20][10];
int    dept_number[10];
EXEC SQL END DECLARE SECTION;
```

- Setting the values of emp\_number, emp\_name, dept\_number

...

- Inserting the values of emp\_number, emp\_name, dept\_number

```
EXEC SQL INSERT INTO emp (empno, ename, deptno)
VALUES (:emp_number, :emp_name, :dept_number);
```

## Using Host Indicator Array

If the host variable is an array, the indicator variable to be combined to it should also be an array. Also, the indicator variable and the host variable should have the same array size. The following is an example of adding the indicator variable to the example above.

```
EXEC SQL BEGIN DECLARE SECTION;
int    emp_number[20];
int    emp_number_ind[20];
char   emp_name[20][10];
int    emp_name_ind[20];
int    dept_number[20];
int    dept_number_ind[20];
EXEC SQL END DECLARE SECTION;
```

- Setting the values of emp\_number, emp\_name, dept\_number
- Setting each indicator value of emp\_number\_ind, emp\_name\_ind, dept\_number\_ind

...

- Inserting the values of emp\_number, emp\_name, dept\_number

```
EXEC SQL INSERT INTO emp (empno, ename, deptno)
VALUES (:emp_number :emp_number_ind,
        :emp_name :emp_name_ind,
        :dept_number :dept_number_ind);
```

## Restrictions

- When using several host variables, it is not allowed to use a mixture of scalar variables and array variables.
- The host array can not be used in WHERE clause of the select statement.
- The host array can not be used in CURRENT OF clause of the update, delete statements.

## Array in INTO Clause

In GOLDILOCKS, rows are fetched by using SELECT INTO statement or cursor. An embedded SQL uses INTO clause in common for both two methods. Multiple rows are fetched by using the host array in INTO clause.

## Array in SELECT INTO

If the number of rows to be fetched is explicitly known, it is implemented by using the host array in **Select Into Statement**. Only the case of when row does not exist or a single row is fetched is described in **Select Into Statement**. However, multiple rows can be fetched by using the host array in it.

The usage is as same as using scalar variables, but the Select Into statement with the array can be created just by declaring the host variable with the array.

```
EXEC SQL BEGIN DECLARE SECTION;
char   emp_name[50][20];
int    emp_number[50];
float  salary[50];
EXEC SQL END DECLARE SECTION;

EXEC SQL SELECT ENAME, EMPNO, SAL
        INTO :emp_name, :emp_number, :salary
        FROM EMP
        WHERE SAL > 1000;
```

In the example above, SELECT INTO statement is used to fetch 50 rows by declaring the host variable with an array. This statement fetches only the first 50 rows which meet the query criteria because it is an independent execution unit.



Even if more than 50 rows meet the query criteria, it can not fetch the rear rows starting from the 51th row by using the SELECT INTO statement. Cursor should be used when continuously fetching rows.

## Array When Using Cursor

If the number of rows in the result set is unknown for the current query, the cursor should be used. For more information about how to use the cursor, refer to **Cursor**. After declaring the cursor, multiple rows can be fetched at once by using the host variable of INTO clause as an array in FETCH statement.

```
EXEC SQL BEGIN DECLARE SECTION;
int    emp_number[50];
char   emp_name[50][20];
char   dept_name[50][20];
EXEC SQL END DECLARE SECTION;

EXEC SQL DECLARE EMP_CURSOR CURSOR FOR
        SELECT empno, ename, dept
```

```

        FROM      EMP
        WHERE     empno < :sNo
        ORDER BY empno;

sNo = 100;
EXEC SQL OPEN EMP_CURSOR;
if(sqlca.sqlcode != 0)
{
    goto fail_exit;
}

while( 1 )
{
    EXEC SQL FETCH EMP_CURSOR INTO :emp_number, :emp_name, :dept_name;
    if(sqlca.sqlcode == SQL_NO_DATA)
    {
        break;
    }
    else if(sqlca.sqlcode != 0)
    {
        goto fail_exit;
    }
    ...
}

```

50 rows can be fetched at once by using the host array in FETCH statement.

## sqlca.sqlerrd[2]

The rows are fetched as many as the declared array size when using an array, but sometimes it can not fetch as many as the declared array size because there is not a row any more. For example, if the array size is declared as 50 and the number of rows in the result set are 30, then only 30 rows can be fetched. To solve this problem, an embedded SQL of GOLDILOCKS provides information about the number of rows processed by the current statement in sqlca.sqlerrd[2].

The number of rows processed in INSERT, UPDATE, DELETE, SELECT INTO, FETCH statements are returned in sqlca.sqlerrd[2].

```

EXEC SQL BEGIN DECLARE SECTION;
    int   emp_number[50];
    char  emp_name[50][20];
    char  dept_name[50][20];
EXEC SQL END DECLARE SECTION;

```

```

EXEC SQL DECLARE EMP_CURSOR CURSOR FOR
    SELECT empno, ename, dept
    FROM EMP
    WHERE empno < :sNo
    ORDER BY empno;

sNo = 100;
EXEC SQL OPEN EMP_CURSOR;
if(sqlca.sqlcode != 0)
{
    goto fail_exit;
}

while( 1 )
{
    EXEC SQL FETCH EMP_CURSOR INTO :emp_number, :emp_name, :dept_name;
    if(sqlca.sqlcode == SQL_NO_DATA)
    {
        break;
    }
    else if(sqlca.sqlcode != 0)
    {
        goto fail_exit;
    }

    for( i = 0; i < sqlca.sqlerrd[2]; i ++ )
    {
        printf( "%d %s %s\n", emp_number[i], emp_name[i], dept_name[i] );
    }
    ...
}

```

For more information about sqlca, refer to [Handling Run-time Errors](#).

## Array in Insert Statement

If the host variable is declared as an array in INSERT statement, the array insert is implemented.

```

EXEC SQL BEGIN DECLARE SECTION;
int emp_number[20];

```

```
char emp_name[20][10];
int dept_number[20];
EXEC SQL END DECLARE SECTION;
```

- Setting the values of emp\_number, emp\_name, dept\_number

...

- Inserting the values of emp\_number, emp\_name, dept\_number

```
EXEC SQL INSERT INTO emp (empno, ename, deptno)
VALUES (:emp_number, :emp_name, :dept_number);
```

The example above has the same feature as the following code.

```
EXEC SQL BEGIN DECLARE SECTION;
int emp_number[20];
char emp_name[20][10];
int dept_number[20];
EXEC SQL END DECLARE SECTION;
```

- Setting the values of emp\_number, emp\_name, dept\_number

...

- Inserting the values of emp\_number, emp\_name, dept\_number

```
for( i = 0; i < 20; i ++ )
{
    EXEC SQL INSERT INTO emp (empno, ename, deptno)
    VALUES (:emp_number[i], :emp_name[i], :dept_number[i]);
}
```



- When using the array insert, all host variables should be array variables or all of them should be scalar variables.
- The number of inserted rows can be checked by using sqlca.sqlerrd[2].

## Atomic Insert

Atomic insert is a special form of the array insert, and it has the following two characteristics.

- If any of the rows to be inserted is failed, the entire insert operation fails.
- The performance is outstanding because the command is transferred only once from the application to GOLDILOCKS.

ATOMIC keyword is used for the atomic insert as follows.

```
EXEC SQL BEGIN DECLARE SECTION;
int    emp_number[20];
char   emp_name[20][10];
int    dept_number[20];
EXEC SQL END DECLARE SECTION;
```

- Setting the values of emp\_number, emp\_name, dept\_number

...

- Inserting the values of emp\_number, emp\_name, dept\_number

```
EXEC SQL ATOMIC INSERT INTO emp (empno, ename, deptno)
VALUES (:emp_number, :emp_name, :dept_number);
```

## Array in Update Statement

The following is an example of using the array in update statement.

```
EXEC SQL BEGIN DECLARE SECTION;
char   job_title [10][20];
float  commission[10];
EXEC SQL END DECLARE SECTION;

...

EXEC SQL UPDATE emp SET comm = :commission
WHERE job = :job_title;
```

The example above has the same feature as the following code.

```
EXEC SQL BEGIN DECLARE SECTION;
char   job_title [10][20];
float  commission[10];
EXEC SQL END DECLARE SECTION;
```

```

...
for( i = 0; i < 10; i ++ )
{
    EXEC SQL UPDATE emp SET comm = :commission[i]
        WHERE job = :job_title[i];
}

```



- When using the array update, all host variables should be array variables or all of them should be scalar variables.
- The number of updated rows can be checked by using `sqlca.sqlerrd[2]`.
- Array can not be used in CURRENT OF clause of UPDATE statement.

## Array in Delete Statement

Array can be used in DELETE statement as follows.

```

EXEC SQL BEGIN DECLARE SECTION;
char job_title[10][20];
EXEC SQL BEGIN DECLARE SECTION;
...
EXEC SQL DELETE FROM emp
    WHERE job = :job_title;

```

The example above has the same feature as the following code.

```

EXEC SQL BEGIN DECLARE SECTION;
char job_title[10][20];
EXEC SQL BEGIN DECLARE SECTION;
...
for( i = 0; i < 10; i ++ )
{
    EXEC SQL DELETE FROM emp
        WHERE job = :job_title[i];
}

```



- When using the array delete, all host variables should be array variables or all of them should be scalar variables.
- The number of deleted rows can be checked by using `sqlca.sqlerrd[2]`.
- Array can not be used in CURRENT OF clause of DELETE statement.



## Using FOR Clause

FOR clause is used to specify the array size when executing the SQL statement. FOR clause can be used in the following statements.

- SELECT INTO
- FETCH
- INSERT
- UPDATE
- DELETE

For clause can be used as follows.

```
EXEC SQL FOR :host_variable <sql_stmt>
EXEC SQL FOR <integer_constant> <sql_stmt>
```

The following is an example of using the for clause.

```
EXEC SQL BEGIN DECLARE SECTION;
int    emp_number[20];
char   emp_name[20][10];
int    dept_number[20];
int    record_cnt;
EXEC SQL END DECLARE SECTION;
```

- Setting the values of emp\_number, emp\_name, dept\_number

...

- Inserting the values of emp\_number, emp\_name, dept\_number

```
record_cnt = 10;
EXEC SQL FOR :record_cnt INSERT INTO emp (empno, ename, deptno)
VALUES (:emp_number, :emp_name, :dept_number);
```

In the example above, the actual number of inserted rows are 10 because the size of the host array is given as 20 but it is specified to perform as much as record\_cnt by using the FOR clause.



FOR clause can not be used with CURRENT OF clause in UPDATE/ DELETE statements.

## Structure Array

Using the general scalar variables as an array has the advantage of processing multiple rows at once, but it has a limit that a variable can represent only a single column.

For more information about how to process multiple columns with a single host variable, refer to **Host Structure**. Multiple rows with multiple columns can be processed at once by declaring a host variable as a structure and using the structure as the array.

A structure array can be used in the following cases.

- Output host variable array: SELECT INTO, FETCH INTO statements
- Input host variable array: VALUES item of INSERT statement

## Restrictions

A structure array can not be used in the following cases.

- It can not be used in WHERE clause or FROM clause.
- It can not be used in SET clause of UPDATE statement.

## Declaring Structure Array

A structure is declared in an way of a common C language structure declaration. A structural variable can be directly declared, or it can be declared as a host variable after declaring type via typedef.

```
EXEC SQL BEGIN DECLARE SECTION;
typedef struct rsRecord
{
    int          mEmpNo;
    varchar      mENAME[20 + 1];
    char         mJob[20 + 1];
    long         mSalary;
} rsRecord;
rsRecord      sRecord[10];

struct {
    int          mEmpNo;
    varchar      mENAME[20 + 1];
    char         mJob[20 + 1];
    long         mSalary;
} sResultRecord[10];
EXEC SQL END DECLARE SECTION;
```

When declaring the structure for using the host variable, the nested structure can not be used. If another structure is inside the structure declaration as follows, it can not be used as a host variable.

```
EXEC SQL BEGIN DECLARE SECTION;
typedef struct rsRecord
{
    struct person {
        int          mEmpNo;
        varchar      mENAME[20 + 1];
    } person;
    char            mJob[20 + 1];
    long           mSalary;
} rsRecord;
EXEC SQL END DECLARE SECTION;
```

## Indicators of Structure Array

As described in **Structure Indicator**, if a host variable is the structure, the Indicator variable should also be the structure. For the same reason, if the host variable is the structure array, the indicator variable should also be the corresponding structure array.

The declaration of the Indicator structure array should comply with the followings.

- It should have the number of members as many as the host variable structure to be combined by the indicator.
- All members of the Indicator structure should have a integer data type.
- The size of the indicator structure array should be as same as that of the host variable structure array. If size of the Indicator structure array is smaller, the number of array executions should be limited by using FOR clause when executing SQL statement.

## Mixed Use of Structure and Scalar Variable

When the host structure is transferred to GOLDILOCKS, its structure members are sequentially listed. The following is an example of mixed use of the host structure and the scalar variable.

```
EXEC SQL BEGIN DECLARE SECTION;
typedef struct rsEmp
{
    int          mEmpNo;
    varchar      mENAME[20 + 1];
} rsEmp;
rsEmp          sEmp[5];
char           sJob[5][20 + 1];
long           sSalary[5];
```

```

EXEC SQL END DECLARE SECTION;

EXEC SQL
    DECLARE EMP_CUR CURSOR FOR
    SELECT empno, ename, job, sal
    FROM EMP
    ORDER BY EMPNO;
EXEC SQL OPEN EMP_CUR;

EXEC SQL
    FETCH EMP_CUR
    INTO :sEmp, :sJob, :sSalary;

```

The structure `rsEmp` and the scalar variables `sJob`, `sSalary` are used together in `FETCH` statement. This statement is internally interpreted as four variables `sEmp.mEmpNo`, `sEmp.mENAME`, `sJob` and `sSalary`. The host structure and the host scalar variable can be used together in this way.

The following is an example of mixed use of the host structure array, structure array indicator, structure array and scalar variable.

```

/*
 * fetch_struct_array.gc
 * : structure array fetch
 * : structure indicators
 * : mix structure, scalar variable
 * : sqlca.sqlerrd[2]
 *
 */
#include <stdio.h>
#include <stdlib.h>
#include <string.h>

EXEC SQL INCLUDE SQLCA;

#define SUCCESS 0
#define FAILURE -1

#define PRINT_SQL_ERROR(aMsg) \
    { \
        printf("\n"); \
        printf(aMsg); \
        printf("\nSQLCODE : %d\nSQLSTATE : %s\nERROR MSG : %s\n", \

```

```

        sqlca.sqlcode,          \
        SQLSTATE,              \
        sqlca.sqlerrm.sqlerrmc ); \
    }
EXEC SQL BEGIN DECLARE SECTION;
typedef struct rsEmp
{
    int          mEmpNo;
    varchar      mENAME[20 + 1];
} rsEmp;
EXEC SQL END DECLARE SECTION;

int Connect(char *aHostInfo, char *aUserID, char *sPassword);

int main(int argc, char **argv)
{
    EXEC SQL BEGIN DECLARE SECTION;
    rsEmp      sEmp[5];
    char        sJob[5][20 + 1];
    long        sSalary[5];
    EXEC SQL END DECLARE SECTION;
    int sRecordCount = 0;
    int i;

    printf("Connect GOLDILOCKS ...\n");
    if(Connect("DSN=GOLDILOCKS", "test", "test") != SUCCESS)
    {
        goto fail_exit;
    }
}

```

- Retrieve employee

```

EXEC SQL
    DECLARE EMP_CUR CURSOR FOR
    SELECT empno, ename, job, sal
    FROM EMP
    ORDER BY EMPNO;

EXEC SQL OPEN EMP_CUR;
if(sqlca.sqlcode != 0)
{

```

```

    PRINT_SQL_ERROR("[ERROR] SQL ERROR -");
    goto fail_exit;
}

printf(" EMPNO      ENAME                JOB      SALARY\n");
printf("===== \n");

while( 1 )
{
    EXEC SQL
        FETCH EMP_CUR
        INTO :sEmp, :sJob, :sSalary;
    if(sqlca.sqlcode == SQL_NO_DATA)
    {
        break;
    }
    else if(sqlca.sqlcode != 0)
    {
        PRINT_SQL_ERROR("[ERROR] SQL ERROR -");
        goto fail_exit;
    }

    sRecordCount += sqlca.sqlerrd[2];

    for( i = 0; i < sqlca.sqlerrd[2]; i ++ )
    {
        printf("%6d %20s %10s %8ld\n",
            sEmp[i].mEmpNo, sEmp[i].mENAME.arr, sJob[i], sSalary[i]);
    }
}

printf("===== \n");
printf("Record Count = %d\n", sRecordCount);
printf("===== \n");

EXEC SQL CLOSE EMP_CUR;
if(sqlca.sqlcode != 0)
{
    PRINT_SQL_ERROR("[ERROR] SQL ERROR -");
    goto fail_exit;
}

```

```

EXEC SQL COMMIT WORK RELEASE;
if(sqlca.sqlcode != 0)
{
    PRINT_SQL_ERROR("[ERROR] SQL ERROR -");
    goto fail_exit;
}

printf("\n\nSUCCESS\n");
printf("#####\n");

return 0;

fail_exit:

printf("\n\nFAILURE\n");
printf("#####\n\n");

EXEC SQL ROLLBACK WORK RELEASE;

return 0;
}

int Connect(char *aHostInfo, char *aUserID, char *sPassword)
{
    EXEC SQL BEGIN DECLARE SECTION;
    VARCHAR sUid[80];
    VARCHAR sPwd[20];
    VARCHAR sConnStr[1024];
    EXEC SQL END DECLARE SECTION;

```

- Log on GOLDILOCKS

```

strcpy((char *)sUid.arr, aUserID);
sUid.len = (short)strlen((char *)sUid.arr);
strcpy((char *)sPwd.arr, sPassword);
sPwd.len = (short)strlen((char *)sPwd.arr);
strcpy((char *)sConnStr.arr, aHostInfo);
sConnStr.len = (short)strlen((char *)sConnStr.arr);

```

- DB connection

```
EXEC SQL CONNECT :sUId IDENTIFIED BY :sPwd USING :sConnStr;
    if(sqlca.sqlcode != 0)
    {
        goto fail_exit;
    }

    return SUCCESS;

fail_exit:

    PRINT_SQL_ERROR("[ERROR] Connection Failure!");

    return FAILURE;
}
```

## Handling Run-time Errors

### Overview

In case when the application can not get the expected result during execution, a preparation is required for this case when developing an embedded SQL application. This chapter explains how to detect the results returned after the SQL execution.

### Detecting Run-time Error

#### SQLCA

All types of errors which occur in an embedded SQL are reported in the area called as SQL Communication Area (SQLCA). Therefore, the application can identify the success of the current operation and the error type by checking the information of SQLCA.

SQLCA is a data structure which stores errors, warnings, SQL statement execution states. SQLCA will only have the results of the last SQL execution which the data structure is combined, but it does not have information about the history of executed SQL statement. If an embedded SQL statement is executed, the existing contents of SQLCA disappears. Therefore, it is necessary to immediately check SQLCA and to perform the exception handling after executing the SQL statement.

#### Using SQLCA

The following syntax is used to use SQLCA.



```
EXEC SQL INCLUDE SQLCA;
```

The syntax above is replaced with the following statement in the precompile process.

```
#include "sqlca.h"
```

This statement should be used before using the first embedded SQL statement, and it is typically recommended to be positioned at the top of the source code.

The embedded SQL application of GOLDLOCKS generally has a global sqlca. In a single thread program, sqlca can be used without any declaration. However, in multi thread program, sqlca is required to be declared separately because the simultaneous accesses to sqlca cause the concurrency problems. For more information, refer to **Multithread Application**.

## SQLCA Structure

The following describes the structure of sqlca.

```
struct sqlca
{
    char    sqlcaid[8];    ❶ It is initialized to the string SQLCA.
    int     sqlabc;       ❷ It is the size of sqlca structure.

    /*
     * ❸ It is the error code which occurred in the most recent statement execution.
     * ❹ If it is 0, it is successful. If it is a positive number, it is a warning. If it is
a negative number, it is an error.
     */
    int     sqlcode;

    /*
     * ❺ It stores the error message for sqlcode
     * ❻ .sqlerrml is the length of sqlerrmc.
     * ❼ .sqlerrmc stores the error message in a string form.
     */
    struct
    {
        unsigned short sqlerrml;
        char            sqlerrmc[SQLERRMC_LEN];
    } sqlerrm;

    char    sqlerrp[8];    /* unused */
    int     sqlerrd[6];
```

```

/* 0: empty */
/* 1: empty */
/* 2: 8 It is the number of rows processed after INSERT, UPDATE, DELETE. */
/* 3: empty */
/* 4: empty */
/* 5: empty */
char sqlwarn[8];
/* 0: 9 If any warning occurs, it is 'W'.
 * 1: 10 If the result string is truncated in SELECT, FETCH, it is 'W'.
 * 2: unused
 * 3: unused
 * 4: unused
 * 5: unused
 * 6: unused
 * 7: unused
 */
char sqlcxt[8]; /* unused */
char sqlstate[8]; /* SQLSTATE */
unsigned short *rowstatus; /* fetched row status array*/
};

```

The next chapter describes the content of each component.

## SQLCODE

SQLCODE is defined as follows.

```
#define SQLCODE (sqlca.sqlcode)
```

SQLCODE executes an embedded SQL statement and then returns the result code. SQLCODE was proposed early in ISO/IEC-9075, but it is deprecated in SQL-92. However, it is provided for the backward compatibility because it is being used in many applications. The result code is as follows.

**Table 33-16** Execution result of SQLCODE

SQLCODE	Result
0	Success
> 0	Warning
SQL_NO_DATA	No result
< 0	Error

sqlcode is checked as follows. sqlca.sqlcode or SQLCODE can be used.

```

EXEC SQL
    DECLARE EMP_CUR CURSOR FOR
    SELECT empno, ename, job, sal
    FROM   EMP;

EXEC SQL OPEN EMP_CUR;
if(SQLCODE != 0)
{
    goto fail_exit;
}
while( 1 )
{
    EXEC SQL
        FETCH EMP_CUR
        INTO  :sEmpNo, :sENAME, :sJob, :sSalary;
    if(sqlca.sqlcode == SQL_NO_DATA)
    {
        break;
    }
    else if(sqlca.sqlcode != 0)
    {
        goto fail_exit;
    }
    ...
}

```

## SQLSTATE

SQLSTATE is defined as follows.

```
#define SQLSTATE      (sqlca.sqlstate)
```

SQLCODE was deprecated in ISO/IEC-9075, and SQLSTATE is proposed instead. SQLSTATE consists of five characters(number, English uppercase alphabet), and the first two digits are called as class, and the rear 3 digits are called as subclass. The result of SQLSTATE are as follows.

**Table 33-17** Execution result of SQLSTATE

SQLSTATE	Result
00000	Success
01xxx	Warning
02000	No result

SQLSTATE	Result
All other states	Error

The code is modified by checking SQLSTATE instead of SQLCODE in the example above as follows. `sqlca.sqlstate` or `SQLSTATE` can be used.

```
EXEC SQL
    DECLARE EMP_CUR CURSOR FOR
    SELECT empno, ename, job, sal
    FROM EMP;

EXEC SQL OPEN EMP_CUR;
if(strcmp(SQLSTATE, "00000") != 0)
{
    goto fail_exit;
}
while( 1 )
{
    EXEC SQL
        FETCH EMP_CUR
        INTO :sEmpNo, :sENAME, :sJob, :sSalary;
    if(strcmp(sqlca.sqlstate, "02000") == 0)
    {
        break;
    }
    else if(strcmp(sqlca.sqlstate, "00000") != 0)
    {
        goto fail_exit;
    }

    ...
}
```

### Number of Processed Rows

When executing update, delete statements or insert, select info, fetch statement using array, it informs a user the number of the processed rows. The information is stored in `sqlca.sqlerrd[2]`. The application refers to the field value and finds out the number of the processed rows. The following is an example of using `sqlca.sqlerrd[2]`.

```

EXEC SQL BEGIN DECLARE SECTION;
    typedef struct rsEmp
    {
        int          mEmpNo;
        varchar      mENAME[20 + 1];
    } rsEmp;
rsEmp    sEmp[5];
char     sJob[5][20 + 1];
long     sSalary[5];
EXEC SQL END DECLARE SECTION;
EXEC SQL
    DECLARE EMP_CUR CURSOR FOR
    SELECT empno, ename, job, sal
    FROM   EMP;

EXEC SQL OPEN EMP_CUR;
if(SQLCODE != 0)
{
    goto fail_exit;
}
while( 1 )
{
    EXEC SQL
        FETCH EMP_CUR
        INTO  :sEmpNo, :sENAME, :sJob, :sSalary;
    if(sqlca.sqlcode == SQL_NO_DATA)
    {
        break;
    }
    else if(sqlca.sqlcode != 0)
    {
        goto fail_exit;
    }

    sRecordCount += sqlca.sqlerrd[2];
    ...
}

```

sqlca.sqlerrd[2] value in fetch statement can be processed as the accumulated number of rows. For more information, refer to **--cumulative** of gpec(Precompiler) option.

### Status of Processed Rows

sqlca.row status indicates the row status which is currently processed. When the row is updated or deleted by using the scroll sensitive cursor or Where CURRENT OF, then the row status can be updated. When using SQL statement with array, It has row status as many as the array size.

**Table 33-18** Referring to the row status

Number of rows	Row status
1	*sqlca.rowstatus
Array size n	sqlca.rowstats[0] sqlca.rowstats[1] sqlca.rowstats[2] ... sqlca.rowstats[n-1]

**Table 33-19** Value of row status

Row status	Description
SQL_ROW_SUCCESS	The row status is normal.
SQL_ROW_DELETED	The row is deleted.
SQL_ROW_UPDATED	The row is updated.
SQL_ROW_NOROW	The row does not exist.
SQL_ROW_ADDED	The row is added.
SQL_ROW_ERROR	The row status is not normal.

The following is an example of referring to the row status.

```
EXEC SQL BEGIN DECLARE SECTION;
    typedef struct rsEmp
    {
        int          mEmpNo;
        varchar      mName[20 + 1];
    } rsEmp;
    rsEmp    sEmp[5];
    char     sJob[5][20 + 1];
    long     sSalary[5];
EXEC SQL END DECLARE SECTION;
EXEC SQL
    DECLARE EMP_CUR CURSOR FOR
    SELECT empno, ename, job, sal
    FROM EMP;

EXEC SQL OPEN EMP_CUR;
```

```

if(SQLCODE != 0)
{
    goto fail_exit;
}
while( 1 )
{
    EXEC SQL
        FETCH EMP_CUR
        INTO :sEmpNo, :sENAME, :sJob, :sSalary;
    if(sqlca.sqlcode == SQL_NO_DATA)
    {
        break;
    }
    else if(sqlca.sqlcode != 0)
    {
        goto fail_exit;
    }

    sRecordCount += sqlca.sqlerrd[2];

    for( i = 0; i < sqlca.sqlerrd[2]; i ++ )
    {
        if( sqlca.rowstatus[i] == SQL_ROW_SUCCESS )
        {
            printf("%6d %20s %10s %8ld\n",
                sEmp[i].mEmpNo, sEmp[i].mENAME.arr, sJob[i], sSalary[i]);
        }
    }

    ...
}

```

### Error Message Text

When an error or warning occurs as a result of the embedded SQL statement, the message can be transferred in a text form. The error message is stored in `sqlca.sqlerrm`, and `sqlca.sqlerrm.sqlerrml` is the length of the text. The actual message is stored in `sqlca.sqlerrm.sqlerrmc`. The error message text is useful to output information to a user when anomalies occur in the application. The following is an example of using an error message text.

```
EXEC SQL INSERT INTO EMP VALUES ( :sEmp );
if( SQLCODE != 0 )
{
    printf("\nSQLCODE : %d\nSQLSTATE : %s\nERROR MSG : %s\n",
        SQLCODE,
        SQLSTATE,
        sqlca.sqlerrm.sqlerrmc );
}
```

## Warning Flags

When a warning occurs after executing the embedded SQL, `sqlca.sqlwarn` is used as the flag which marks the warning. It consists of eight char arrays, and the mark of 'W' is used when the warning occurs.

**Table 33-20** Warning flags

Warning flag	Description
<code>sqlca.sqlwarn[0]</code>	If any warning occurs, it is 'W'.
<code>sqlca.sqlwarn[1]</code>	If the result string is truncated in select into, fetch, then it is 'W'.
<code>sqlca.sqlwarn[2]</code>	reserved
<code>sqlca.sqlwarn[3]</code>	reserved
<code>sqlca.sqlwarn[4]</code>	reserved
<code>sqlca.sqlwarn[5]</code>	reserved
<code>sqlca.sqlwarn[6]</code>	reserved
<code>sqlca.sqlwarn[7]</code>	reserved

## Handling Implicit Error

After executing the embedded SQL statement, a user should check SQLCA and take action into the execution result. However, when treating the same exception occurs after executing the embedded SQL statement, it can be automated by using WHENEVER indicator.

## Using WHENEVER Statement

WHENEVER statement has the following syntax.

```
EXEC SQL WHENEVER conditions actions;
```

## WHENEVER Condition

Conditions of WHENEVER statement are as follows.



```

<conditions> ::=
    SQLERROR
  | SQLWARNING
  | NOT FOUND
  | SQLSTATE <sqlstate class value>[<sqlstate subclass value>]
  ;

<sqlstate_char> ::= [0-9A-Z];
<sqlstate class value> ::= <sqlstate_char><sqlstate_char>;
<sqlstate subclass value> ::= <sqlstate_char><sqlstate_char><sqlstate_char>;

```

**Table 33-21** Conditions of WHENEVER statement

Conditions	Descriptions
SQLERROR	An error occurs while an embedded SQL is executed.
SQLWARNING	A warning occurs while an embedded SQL is executed.
NOT FOUND	A result row does not exist.
SQLSTATE <sqlstate>	SQLSTATE <sqlstate> occurs while an embedded SQL is executed.

## WHENEVER Action

When actions meet the conditions described above, it describes the action actually performed, and its syntax is as follows.

```

<actions> ::=
    CONTINUE
  | GOTO <label>
  | STOP
  | DO <c statements>
  ;

```

**Table 33-22** Actions of WHENEVER statement

Actions	Description
CONTINUE	An action is not performed. It ignores the given conditions.
GOTO <label>	It branches the program flow with <label>.
STOP	It terminates the program execution.
DO <c statements>	It executes <c statements>.

## Scope of WHENEVER Statement

WHENEVER statement describes actions for conditions, and only one action can be described for one condition. When using WHENEVER statement, the same action is used for all embedded SQL statements until

If the definition of another condition comes after the current condition.

Maximum four WHENEVER statements can be applied for a specific point because WHENEVER statements are separately managed by each condition. If a new WHENEVER statement is applied for the same condition, the existing action is canceled and a new action may be applied afterwards. The following is an example.

```
EXEC SQL WHENEVER SQLERROR STOP;
EXEC SQL INSERT INTO emp VALUES ( :emp_number, :emp_name, :salary ); ❶
...
EXEC SQL WHENEVER SQLERROR CONTINUE;
EXEC SQL UPDATE emp SET sal = sal * 1.1 WHERE sal < :sal_bound; ❷
...
EXEC SQL WHENEVER SQLERROR GOTO exit_label;
EXEC SQL WHENEVER NOT FOUND DO break;
EXEC SQL DECLARE EMP_CURSOR FOR
    SELECT empno, ename, sal
    FROM emp;

EXEC SQL OPEN EMP_CURSOR; ❸

EXEC SQL WHENEVER SQLERROR GOTO close_label;
while( 1 )
{
    EXEC SQL FETCH EMP_CURSOR
        INTO :emp_number, :emp_name, :salary; ❹

    printf( "emp number : %d, emp name : %s, salary : %lf\n",
        emp_number, emp_name, salary );
}
close_label:
EXEC SQL WHENEVER SQLERROR DO sql_error();
EXEC SQL CLOSE EMP_CURSOR; ❺
...
exit_label:
...
```

The application is stopped when an error occurs during executing ❶ because the stop operation is specified for SQLERROR in line 1. SQLERROR action is changed to proceed without performing any action because CONTINUE is indicated for SQLERROR in line 4. Therefore, it proceeds to the next even when an error occurs during executing ❷. It branches to exit\_label when an error occurs during executing ❸ because the SQLERROR action is set to branch to exit\_label in line 7. It is specified to perform break for NOT FOUND

in line 8, and SQLERROR action is reassigned as close\_label in line 15. Therefore, two conditions are applied to ④. When an error occurs during FETCH, it branches to close\_label, and if the FETCH result does not exist, then the break statement is executed. sql\_error() function is called when an error occurs during executing ⑤ because SQLERROR action is specified to execute sql\_error() in line 26.

## Notice for WHENEVER statement

WHENEVER statement should be used carefully after understanding the operation principle. The following should be considered when using the WHENEVER statement.

- The position of WHENEVER statement on the source code: WHENEVER statement is an indicator which informs to automatically insert the exception handling code to precompiler, and it is not a logically executable code. WHENEVER should be at the beginning of the embedded SQL statements to be applied on the source code. CONTINUE action should be used to initialize not to affect the following embedded SQL.
- Using the break, continue keywords: If DO break, DO continue are used in an action clause, the loop scope should be checked and used. The following is an example.

```
EXEC SQL WHENEVER SQLERROR GOTO fail_exit;
EXEC SQL WHENEVER NOT FOUND DO break; ①
EXEC SQL DECLARE EMP_CURSOR FOR
        SELECT empno, ename, sal
        FROM emp;

EXEC SQL OPEN EMP_CURSOR;
while( 1 )
{
    EXEC SQL FETCH EMP_CURSOR
        INTO :emp_number, :emp_name, :salary; ②
    printf( "emp number : %d, emp name : %s, salary : %lf\n",
        emp_number, emp_name, salary );
}
EXEC SQL CLOSE EMP_CURSOR;

EXEC SQL
    SELECT MAX(sal)
    INTO :max_salary
    FROM emp; ③
...

```

break; may be performed for NOT FOUND in subsequent SQL statements because the action for NOT FOUND is defined as DO break; in ①. When NOT FOUND occurs in ② during FETCH, break is performed and it exits the while loop. However, break can not be performed when NOT FOUND occurs in ③ because

it is not a loop. In this case, the compile error occurs when building the source program and developing the application

- Avoiding infinite loop

If it is misused when branching to the action, it causes the infinite loop. The following is an example.

```
EXEC SQL WHENEVER SQLERROR GOTO sql_error;
...
EXEC SQL INSERT INTO emp VALUES ( :emp_number, :emp_name, :salary );
...
sql_error:
    EXEC SQL ROLLBACK WORK RELEASE;
```

When an error occurs during executing the SQL statement, it branches to sql\_error label. When an error occurs during executing the embedded SQL statement, it branches to sql\_error. However, when the error repeatedly occurs during executing another embedded SQL statement in an error processing, the application infinitely loops. In this case, the following is recommended to safely initialize the error handling.

```
EXEC SQL WHENEVER SQLERROR GOTO sql_error;
...
EXEC SQL INSERT INTO emp VALUES ( :emp_number, :emp_name, :salary );
...
sql_error:
    EXEC SQL WHENEVER SQLERROR CONTINUE;
    EXEC SQL ROLLBACK WORK RELEASE;
```

- Scope of branch label

If it is branched in an action, its label should be located in an accessible position. The following is an example.

```
func1()
{
    EXEC SQL WHENEVER SQLERROR GOTO labelA;
    EXEC SQL DELETE FROM emp WHERE deptno = :dept_number;
    ...
labelA:
    ...
}
func2()
```

```

{
    EXEC SQL INSERT INTO emp (job) VALUES (:job_title);
    ...
}

```

In `func1()`, the branching the `labelA` is specified for `SQLERROR`. However, the compile error occurs because `labelA` exists in `func1()` but it does not exist in `func2()`. In this case, the same `labelA` should be created in `func2()` or the action should be initialized as follows.

```

func1()
{
    EXEC SQL WHENEVER SQLERROR GOTO labelA;
    EXEC SQL DELETE FROM emp WHERE deptno = :dept_number;
    ...
labelA:
    ...
}
func2()
{
    EXEC SQL WHENEVER SQLERROR CONTINUE;
    EXEC SQL INSERT INTO emp (job) VALUES (:job_title);
    ...
}

```

## 33.3 Advanced Topic

### Embedded Dynamic SQL

#### Overview

Most of the embedded SQL applications perform the specific operations on GOLDILOCKS. They are to insert, update, delete, retrieve rows and they are specified by using the database language called as SQL. When SQL is directly specified on the embedded SQL source code for this purpose, the precompiler interpretes the SQL, and converts it to an API call available to GOLDILOCKS on the state of knowing all the given SQL and input/output host variables.

However, some applications do not know the SQL in advance when developing the applications. For example, if static SQL is used in an application such as GUI tool when the user wants to query by selecting the operation type, the table name, condition, the user should specify all SQL statement of possible combination in advance. However, it is impossible or it is very inefficient even when it is possible. In this case, if the user generates and executes the SQL statement with a user selectable option, it might be very flexible and efficient. The dynamic SQL is the SQL which is not defined on the source code in advance and is changed at run-time. GOLDILOCKS supports the embedded dynamic SQL feature.

The advantage of embedded dynamic SQL application provides more flexible usage compared to the static SQL, but the disadvantage is that the development of the source code is difficult and it has poor performance compared to the static SQL when performing the same query.

It is recommended to compare the static SQL and the dynamic SQL, then select one of them considering these features carefully when developing applications.

This chapter describes how to develop the embedded dynamic SQL program.

#### Dynamic SQL Types

The dynamic SQLs are classified according the usage as follows.

**Table 33-23** Dynamic SQL type

Method	Description	Support
Method 1	It is a non-query and a host variable does not exist.	O
Method 2	It is a non-query and a host variable may know the number and type.	O
Method 3	It is a query and a host variable may know the number and type.	O
Method 4	It is a query, and the existence of host variable, the number and type are unknown.	X

Currently, GOLDILOCKS supports until the method 3.

## Method 1

It is the simplest form of the dynamic SQL, and it is a non-query and can be used when a host variable does not exist. Typically, it is used for the DDL or for the DML in which the host variable does not exist.

- EXECUTE IMMEDIATE

The SQL statement can be immediately executed because the method1 is a non-query and it does not have the host variable at the same time. The syntax of the immediate execution of SQL is as follows.

```
EXEC SQL EXECUTE IMMEDIATE { :host_variable | <string_literal> };
<string_literal> ::=
    ' <sql_statement> '
  | " <sql_statement> "
  | <sql_statement>
  ;
```

The method 1 is used as follows.

```
sprintf(sSqlStmt, "CREATE TABLE EMP_RND (\n"
        "EMPNO NUMBER(4) CONSTRAINT PK_EMP_RND PRIMARY KEY,\n"
        "ENAME VARCHAR2(10),\n"
        "JOB VARCHAR2(9),\n"
        "SAL NUMBER(7,2),\n"
        "DEPTNO NUMBER(2) )\n" );
EXEC SQL EXECUTE IMMEDIATE :sSqlStmt;
if(sqlca.sqlcode != 0)
{
    goto fail_exit;
}
sprintf(sSqlStmt, "INSERT INTO EMP_RND\n"
        "SELECT *\n"
        "FROM EMP\n"
        "WHERE JOB = 'RND'\n" );
EXEC SQL EXECUTE IMMEDIATE :sSqlStmt;
if(sqlca.sqlcode != 0)
{
    goto fail_exit;
}
```

## Method 2

The method 2 is used for the non-query with an existence of input host variable. The number of input host variables and the data type should be known, and it is performed through preparation step and the execution step.

- Prepare

In the prepare step, the SQL statement is analyzed, and the name is given to this statement. The syntax of prepare is as follows.

```
EXEC SQL PREPARE <statement_name> FROM { :host_variable | <string_literal> };
<string_literal> ::=
    ' <sql_statement> '
  | " <sql_statement> "
  | <sql_statement>
  ;
```

<statement\_name> is an identifier notifying to the precompiler. It does not require a separate type or any declaration of a variable because it is not the host variable.

- Execute

The analyzed statement is executed in the execute step. The syntax of execute statement is as follows.

```
EXEC SQL EXECUTE <statement_name> [ USING <host_variable_list> ];
<host_variable_list> ::= <host_variable_entry> [ , <host_variable_list> ];
<host_variable_entry> ::= :host_variable [ [ INDICATOR ] :host_indicator ] ;
```

If an input host variable exist, USING clause is used. If the host variable does not exist, USING clause is omitted. It is bound to the host variable of the prepared SQL statement according to the sequence of host variables in USING clause.

When the same SQL statements are repeatedly executed in method 2, execute may be repeatedly performed after performing prepare only once. The prepared statement is valid in the current source code until another SQL statement is prepared with the same statement name or it is disconnected.

## Method 3

The method 3 is an extended form of the method 2 to support the query. The statements of declare, open, fetch, close are added for the cursor because generally a statement is analyzed in the query prepare process and the cursor should be handled for the query.

- Prepare



The prepare step analyzes the SQL statement as like the method 2, and gives the name to the statement. The syntax of prepare is as follows.

```
EXEC SQL PREPARE <statement_name> FROM { :host_variable | <string_literal> };
<string_literal> ::=
    ' <sql_statement> '
  | " <sql_statement> "
  | <sql_statement>
  ;
```

<statement\_name> is an identifier notifying to the precompiler. It does not require a separate type or any declaration of a variable because it is not the host variable.

- Declare cursor

Declare statement declares the cursor for the prepared statement. When declaring the cursor, the cursor property which is as same as the standing cursor can be used. The syntax is as follows.

```
EXEC SQL <dynamic declare cursor>;

<dynamic declare cursor> ::=
    DECLARE <cursor_name> <cursor properties> { FOR | IS } <statement_name>
    ;

<cursor properties> ::=
    [ <cursor sensitivity> ] [ <cursor scrollability> ] CURSOR [ <cursor holdability> ]
  | [ <odbc cursor type> ] CURSOR [ <cursor holdability> ]
  ;

<cursor sensitivity> ::=
    INSENSITIVE
  | SENSITIVE
  | ASENSITIVE
  ;

<cursor scrollability> ::=
    NO SCROLL
  | SCROLL
  ;

<cursor holdability> ::=
    WITH HOLD
  | WITHOUT HOLD
  ;

<odbc cursor type> ::=
    STATIC
```

```
| KEYSET
;
```

The meaning and used name of <cursor properties> is as same as the standing cursor.

<statement\_name> is the name specified in PREPARE statement. <cursor name> and <statement name> are the identifiers notifying to the precompiler. It does not require a separate type or any declaration of a variable because it is not the host variable.

Only one cursor can be declared per one statement. If another cursor is declared when there is a cursor already declared in the statement, then the existing cursor is closed.

- Open cursor

It opens the cursor. It is generally same with the **Open Cursor** of the standing cursor, but there is a significant and typical difference in opening the dynamic cursor. The host variable is determined depending on the declared SQL statement because the dynamic cursor updates and uses the SQL statement freely at the run-time. Therefore, when opening the dynamic cursor, it transfers the host variable by using the USING clause at the time of opening. The cursor should be closed at the time of opening the standing cursor, but the dynamic cursor is opened after closing the cursor.

Open syntax of dynamic cursor is as follows.

```
EXEC SQL <dynamic cursor open>;

<dynamic cursor open> ::=
    OPEN <cursor_name> [ USING <host_variable_list> ]
    ;

<host_variable_list> ::= <host_variable_entry> [ , <host_variable_list> ];
<host_variable_entry> ::= :host_variable [ [ INDICATOR ] :host_indicator ];
```

- Fetch cursor

It fetches from the cursor. Fetching dynamic cursor is as same as **fetching standing cursor**.

- Close cursor

It closes the cursor. Closing dynamic cursor is as same as **closing standing cursor**.

## Example Program

The following is a sample program of using the dynamic method 1, 2, 3.

```

/*
 * dyn2.gc
 * : dynamic method 1
 * : dynamic method 2
 * : dynamic method 3
 *
 */
#include <stdio.h>
#include <stdlib.h>
#include <string.h>
EXEC SQL INCLUDE SQLCA;

#define SUCCESS 0
#define FAILURE -1
#define PRINT_SQL_ERROR(aMsg) \
    { \
        printf("\n"); \
        printf(aMsg); \
        printf("\nSQLCODE : %d\nSQLSTATE : %s\nERROR MSG : %s\n", \
            sqlca.sqlcode, \
            SQLSTATE, \
            sqlca.sqlerrm.sqlerrmc ); \
    }

EXEC SQL BEGIN DECLARE SECTION;
typedef struct Record
{
    int          mEmpNo;
    varchar      mENAME[20 + 1];
    char         mJob[20];
    char         mSalary[10];
} Record;
EXEC SQL END DECLARE SECTION;

int Connect(char *aHostInfo, char *aUserID, char *sPassword);
int CreateEmpTempTable();
int DropEmpTempTable();
int UpdateSalary(char *aJob, int aBound, double aRatio);

int main(int argc, char **argv)
{

```

```

EXEC SQL BEGIN DECLARE SECTION;
EXEC SQL END DECLARE SECTION;
printf("Connect GOLDILOCKS ...\n");
if(Connect("DSN=GOLDILOCKS", "test", "test") != SUCCESS)
{
    goto fail_exit;
}

if(CreateEmpTempTable() != SUCCESS)
{
    goto fail_exit;
}

```

- Print RND employee increase 20% salary where salary < 2000

```

printf("print RND employee increase 20%% salary where salary < 2000\n");
UpdateSalary( "RND", 2000, 1.2 );
printf("\n\n");

```

- Print SUPPORT employee increase 10% salary where salary < 3000

```

printf("print SUPPORT employee increase 10%% salary where salary < 3000\n");
UpdateSalary( "SUPPORT", 3000, 1.1 );
printf("\n\n");

if(DropEmpTempTable() != SUCCESS)
{
    goto fail_exit;
}

printf("Disconnect GOLDILOCKS ...\n");
EXEC SQL COMMIT WORK RELEASE;
if(sqlca.sqlcode != 0)
{
    PRINT_SQL_ERROR("[ERROR] SQL ERROR -");
    goto fail_exit;
}

printf("SUCCESS\n");
printf("#####\n");

return 0;

```

```
fail_exit:
```

```
    printf("\n\nFAILURE\n");
    printf("#####\n\n");
    EXEC SQL ROLLBACK WORK RELEASE;
```

```
    return 0;
```

```
}
```

```
int Connect(char *aHostInfo, char *aUserID, char *sPassword)
```

```
{
```

```
    EXEC SQL BEGIN DECLARE SECTION;
    VARCHAR sUid[80];
    VARCHAR sPwd[20];
    VARCHAR sConnStr[1024];
    EXEC SQL END DECLARE SECTION;
```

- Log on GOLDILOCKS

```
strcpy((char *)sUid.arr, aUserID);
```

```
    sUid.len = (short)strlen((char *)sUid.arr);
```

```
    strcpy((char *)sPwd.arr, sPassword);
```

```
    sPwd.len = (short)strlen((char *)sPwd.arr);
```

```
    strcpy((char *)sConnStr.arr, aHostInfo);
```

```
    sConnStr.len = (short)strlen((char *)sConnStr.arr);
```

- DB connection

```
EXEC SQL CONNECT :sUid IDENTIFIED BY :sPwd USING :sConnStr;
```

```
    if(sqlca.sqlcode != 0)
```

```
    {
```

```
        goto fail_exit;
```

```
    }
```

```
    return SUCCESS;
```

```
fail_exit:
```

```
    PRINT_SQL_ERROR("[ERROR] Connection Failure!");
```

```
    return FAILURE;
```

```
}

```

- Create table

```
int CreateEmpTempTable()
{
    EXEC SQL BEGIN DECLARE SECTION;
    char   sSqlStmt[8192];
    EXEC SQL END DECLARE SECTION;
    sprintf(sSqlStmt, "DROP TABLE IF EXISTS EMP_RND" );
    EXEC SQL EXECUTE IMMEDIATE :sSqlStmt;
    if(sqlca.sqlcode != 0)
    {
        goto fail_exit;
    }

    sprintf(sSqlStmt, "CREATE TABLE EMP_RND (\n"
        "EMPNO NUMBER(4) CONSTRAINT PK_EMP_RND PRIMARY KEY,\n"
        "ENAME VARCHAR2(10),\n"
        "JOB VARCHAR2(9),\n"
        "SAL NUMBER(7,2),\n"
        "DEPTNO NUMBER(2) )\n" );
    EXEC SQL EXECUTE IMMEDIATE :sSqlStmt;
    if(sqlca.sqlcode != 0)
    {
        goto fail_exit;
    }

    sprintf(sSqlStmt, "INSERT INTO EMP_RND\n"
        "SELECT *\n"
        "FROM   EMP\n"
        "WHERE  JOB = 'RND'\n" );
    EXEC SQL EXECUTE IMMEDIATE :sSqlStmt;
    if(sqlca.sqlcode != 0)
    {
        goto fail_exit;
    }

    sprintf(sSqlStmt, "DROP TABLE IF EXISTS EMP_SUPPORT" );
    EXEC SQL EXECUTE IMMEDIATE :sSqlStmt;
    if(sqlca.sqlcode != 0)

```

```

{
    goto fail_exit;
}

sprintf(sSqlStmt, "CREATE TABLE EMP_SUPPORT (\n"
        "EMPNO NUMBER(4) CONSTRAINT PK_EMP_SUPPORT PRIMARY KEY,\n"
        "ENAME VARCHAR2(10),\n"
        "JOB VARCHAR2(9),\n"
        "SAL NUMBER(7,2),\n"
        "DEPTNO NUMBER(2) )\n" );
EXEC SQL EXECUTE IMMEDIATE :sSqlStmt;
if(sqlca.sqlcode != 0)
{
    goto fail_exit;
}

sprintf(sSqlStmt, "INSERT INTO EMP_SUPPORT\n"
        "SELECT *\n"
        "FROM EMP\n"
        "WHERE JOB = 'SUPPORT'\n" );
EXEC SQL EXECUTE IMMEDIATE :sSqlStmt;
if(sqlca.sqlcode != 0)
{
    goto fail_exit;
}

EXEC SQL COMMIT WORK;
if(sqlca.sqlcode != 0)
{
    goto fail_exit;
}

return SUCCESS;

fail_exit:

PRINT_SQL_ERROR("[ERROR] SQL ERROR -");
EXEC SQL ROLLBACK WORK;

return FAILURE;
}

```

- Drop table

```
int DropEmpTempTable()
{
    EXEC SQL DROP TABLE EMP_RND;
    if(sqlca.sqlcode != 0)
    {
        goto fail_exit;
    }

    EXEC SQL DROP TABLE EMP_SUPPORT;
    if(sqlca.sqlcode != 0)
    {
        goto fail_exit;
    }

    EXEC SQL COMMIT WORK;
    if(sqlca.sqlcode != 0)
    {
        goto fail_exit;
    }

    return SUCCESS;

fail_exit:

    PRINT_SQL_ERROR("[ERROR] SQL ERROR -");
    EXEC SQL ROLLBACK WORK;

    return FAILURE;
}

int UpdateSalary(char *aJob, int aBound, double aRatio)
{
    EXEC SQL BEGIN DECLARE SECTION;
    Record      sRecord;
    char        sSelectSql[128];
    char        sUpdateSql[128];
    int         sBound = aBound;
    double      sRatio = aRatio;
    EXEC SQL END DECLARE SECTION;
```



```
int sRecordCount = 0;
int i;
int sIsOpenCur = 0;

sprintf( sSelectSql, "SELECT EMPNO, ENAME, JOB, SAL FROM EMP_%s WHERE sal < :v1 FOR
UPDATE", aJob );
sprintf( sUpdateSql, "UPDATE EMP_%s SET sal = sal * :v1 WHERE CURRENT OF DYN_CUR", aJob);

EXEC SQL PREPARE SELECT_STMT FROM :sSelectSql;
if(sqlca.sqlcode != 0)
{
    goto fail_exit;
}

EXEC SQL DECLARE DYN_CUR KEYSET CURSOR FOR SELECT_STMT;
EXEC SQL OPEN DYN_CUR USING :sBound;
if(sqlca.sqlcode != 0)
{
    goto fail_exit;
}
sIsOpenCur = 1;

EXEC SQL PREPARE UPDATE_STMT FROM :sUpdateSql;
if(sqlca.sqlcode != 0)
{
    goto fail_exit;
}

while( 1 )
{
    EXEC SQL
        FETCH NEXT DYN_CUR
        INTO :sRecord;
    if(sqlca.sqlcode == SQL_NO_DATA)
    {
        break;
    }
    else if(sqlca.sqlcode != 0)
    {
        goto fail_exit;
    }
}
```

```

    }

    EXEC SQL EXECUTE UPDATE_STMT USING :sRatio;
    if(sqlca.sqlcode != 0)
    {
        goto fail_exit;
    }
}

sIsOpenCur = 0;
EXEC SQL CLOSE DYN_CUR;
if(sqlca.sqlcode != 0)
{
    goto fail_exit;
}

sprintf( sSelectSql, "SELECT EMPNO, ENAME, JOB, SAL FROM EMP_%s ORDER BY SAL DESC", aJob
);
EXEC SQL PREPARE SELECT_STMT FROM :sSelectSql;
if(sqlca.sqlcode != 0)
{
    goto fail_exit;
}

EXEC SQL OPEN DYN_CUR;
if(sqlca.sqlcode != 0)
{
    goto fail_exit;
}
sIsOpenCur = 1;

printf("%s salary list\n", aJob);
sRecordCount = 0;
printf(" EMPNO      ENAME                JOB          SALARY\n");
printf("===== \n");
while( 1 )
{
    EXEC SQL
        FETCH DYN_CUR
        INTO :sRecord;
    if(sqlca.sqlcode == SQL_NO_DATA)

```

```

    {
        break;
    }
    else if(sqlca.sqlcode != 0)
    {
        PRINT_SQL_ERROR("[ERROR] SQL ERROR -");
        goto fail_exit;
    }

    for(i = 0; i < sqlca.sqlerrd[2]; i ++)
    {
        sRecordCount ++;
        printf("%6d %20s %10s %10s\n",
            sRecord.mEmpNo,
            sRecord.mENAME.arr,
            sRecord.mJob,
            sRecord.mSalary);
    }
}

printf("=====  

printf("Record Count = %d\n", sRecordCount);
printf("=====  

sIsOpenCur = 0;
EXEC SQL CLOSE DYN_CUR;
if(sqlca.sqlcode != 0)
{
    goto fail_exit;
}

return SUCCESS;

fail_exit:

PRINT_SQL_ERROR("[ERROR] SQL ERROR -");
if(sIsOpenCur == 1)
{
    EXEC SQL CLOSE DYN_CUR;
}
return FAILURE;

```

| }

## Multithread Application

The multithreaded application is an application including multiple execution units in a single process. The multithreaded application can process multiple tasks such as running multiple applications at the same time in parallel, and it has the advantage of being able to share the same address scope because it is a single process.

Sharing the same address scope means sharing the global variables and static variables. When accessing these variables, the concurrency control for each thread should be considered. Therefore, the application should be developed very carefully.

GOLDILOCKS supports the run-time context. The run-time context has a slight difference between Direct Attach (D/A) mode and Client/Server (C/S) mode. The next chapter describes the run-time context and the guideline for developing the multithreaded application.

## Run-time Context

The run-time context in an embedded SQL of GOLDILOCKS is used for the purpose of managing the connection from the application to GOLDILOCKS. The relationship between the run-time context and connection is 1:1, and the run-time context is regarded as the connection itself.

GOLDILOCKS structurally allows only a single connection in a thread in D/A mode. The multithreaded application is required for multiple connections. However, it is the connection with the server via network in C/S mode, so a single thread may have multiple connections.

## Direct Attach (D/A) Mode

A single thread has only a single connection in D/A mode. Therefore, n threads are required when developing an application with n connections.

**Figure 2** In case when each thread has its own connection in D/A mode

Embeddded SQL main application

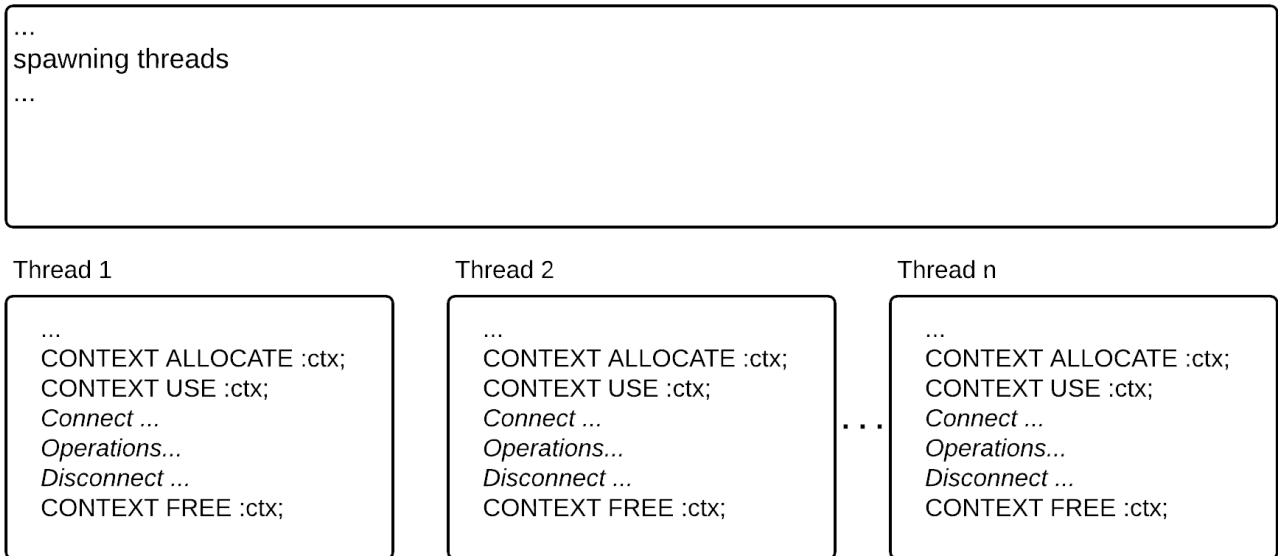

### Client/Server (C/S) Mode

An extra restriction for the connection does not exist when operating in C/S mode. A single thread may have multiple connections or multiple threads may share a single connection. N threads can share m connections.

**Figure 3** In case when multiple threads share a single connection

Embeddded SQL main application

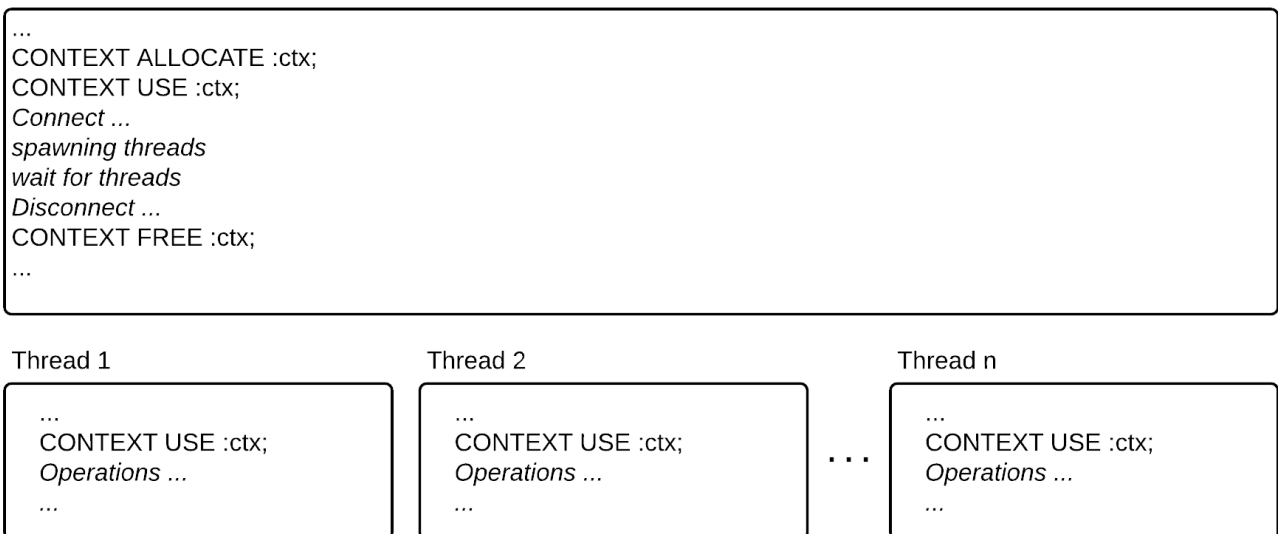

**Figure 4** In case when a single thread has multiple connections**Embedded SQL main application**

```

...
CONTEXT ALLOCATE :ctx1;
CONTEXT ALLOCATE :ctx2;
CONTEXT ALLOCATE :ctx3;

CONTEXT USE :ctx1;
Connect ...
CONTEXT USE :ctx2;
Connect ...
CONTEXT USE :ctx3;
Connect ...

CONTEXT USE :ctx1;
SQL operations ...
CONTEXT USE :ctx2;
SQL operations ...
CONTEXT USE :ctx3;
SQL operations ...

CONTEXT USE :ctx1;
Disconnect ...
CONTEXT USE :ctx2;
Disconnect ...
CONTEXT USE :ctx3;
Disconnect ...

CONTEXT FREE :ctx1;
CONTEXT FREE :ctx2;
CONTEXT FREE :ctx3;
...

```

## Guidelines

The followings should be considered to develop the multithreaded application.

- The SQLCA variable should be declared thread-safely. It is recommended to declare as a stack variable in each thread, and to refer to the example program of the next chapter.
- The static variables or the global variables are shared because the multithread has the same address space in a single process. The concurrency control should be considered when using these variables.
- A single run-time context should not be allowed to be used at the same time in multiple threads. The concurrency control of run-time context should also be considered.

## Example Program

The following is a sample program of a multithreaded application.

```

/*
 * thread1.gc
 *
 */
#include <stdio.h>
#include <stdlib.h>
#include <string.h>
#include <pthread.h>

EXEC SQL INCLUDE SQLCA;

#define SUCCESS 0
#define FAILURE -1

#define PRINT_SQL_ERROR(aMsg) \
{ \
    printf("\n"); \
    printf(aMsg); \
    printf("\nSQLCODE : %d\nSQLSTATE : %s\nERROR MSG : %s\n", \
        sqlca.sqlcode, \
        SQLSTATE, \
        sqlca.sqlerrm.sqlerrmc ); \
}

int Connect(sql_context aCtx, char *aHostInfo, char *aUserID, char *sPassword);
int CreateEmpTempTable();
int DropEmpTempTable();
void *clientThread(void *args);

typedef struct thread_param
{
    int    mNo;
    char  *mJobName;
} thread_param;

#define THREAD_COUNT 2
char gJobName[THREAD_COUNT][20]= {

```

```

    "RND",
    "SUPPORT"
};

int main(int argc, char **argv)
{
    EXEC SQL BEGIN DECLARE SECTION;
    int          sEmpNo;
    varchar      sENAME[20 + 1];
    char         sJob[20];
    long         sSalary;
    EXEC SQL END DECLARE SECTION;
    int          sRecordCount = 0;
    pthread_t    thread_id[THREAD_COUNT];
    thread_param param[THREAD_COUNT];
    int          i;

    printf("Connect GOLDBLOCKS ...\n");
    if(Connect(NULL, "DSN=GOLDBLOCKS", "test", "test") != SUCCESS)
    {
        goto fail_exit;
    }

    if(CreateEmpTempTable() != SUCCESS)
    {
        goto fail_exit;
    }
}

```

- Create client thread

```

for( i = 0; i < THREAD_COUNT; i ++ )
{
    param[i].mNo = i;
    param[i].mJobName = gJobName[i];
    if( pthread_create(&thread_id[i],
                      NULL,
                      clientThread,
                      &param[i]) != 0 )
    {
        printf( "Can't create thread %d!\n", i );
    }
}

```



```

    else
    {
        printf( "Create thread %d!\n", i );
    }
}

for( i = 0; i < THREAD_COUNT; i ++ )
{
    if( pthread_join(thread_id[i],
                    NULL) != 0 )
    {
        printf( "Error when waiting for thread %d to terminate!\n", i );
    }
    else
    {
        printf( "Stopped thread %d!\n", i );
    }
}

```

- Retrieve employee

#### EXEC SQL

```

    DECLARE EMP_CUR CURSOR FOR
    SELECT empno, ename, job, sal
    FROM   EMP_TEMP
    ORDER BY empno;

EXEC SQL OPEN EMP_CUR;
if(sqlca.sqlcode != 0)
{
    PRINT_SQL_ERROR("[ERROR] SQL ERROR -");
    goto fail_exit;
}

printf(" EMPNO      ENAME                JOB      SALARY\n");
printf("===== \n");
while( 1 )
{
    EXEC SQL
        FETCH EMP_CUR
        INTO  :sEmpNo, :sENAME, :sJob, :sSalary;

```

```
    if(sqlca.sqlcode == SQL_NO_DATA)
    {
        break;
    }
    else if(sqlca.sqlcode != 0)
    {
        PRINT_SQL_ERROR("[ERROR] SQL ERROR -");
        goto fail_exit;
    }

    sRecordCount ++;

    printf("%6d %20s %10s %8ld\n",
           sEmpNo, sENAME.arr, sJob, sSalary);
}

printf("=====\n");
printf("Record Count = %d\n", sRecordCount);
printf("=====\n");

EXEC SQL CLOSE EMP_CUR;
if(sqlca.sqlcode != 0)
{
    PRINT_SQL_ERROR("[ERROR] SQL ERROR -");
    goto fail_exit;
}

if(DropEmpTempTable() != SUCCESS)
{
    goto fail_exit;
}

EXEC SQL COMMIT WORK RELEASE;
if(sqlca.sqlcode != 0)
{
    PRINT_SQL_ERROR("[ERROR] SQL ERROR -");
    goto fail_exit;
}

printf("SUCCESS\n");
printf("#####\n");
```

```

    return 0;

fail_exit:

    printf("FAILURE\n");
    printf("#####\n\n");
    EXEC SQL ROLLBACK WORK RELEASE;

    return 0;
}

int Connect(sql_context aCtx, char *aHostInfo, char *aUserID, char *sPassword)
{
    EXEC SQL BEGIN DECLARE SECTION;
    VARCHAR sUid[80];
    VARCHAR sPwd[20];
    VARCHAR sConnStr[1024];
    EXEC SQL END DECLARE SECTION;
    struct sqlca sqlca;

```

- Log on GOLDILOCKS

```

strcpy((char *)sUid.arr, aUserID);
sUid.len = (short)strlen((char *)sUid.arr);
strcpy((char *)sPwd.arr, sPassword);
sPwd.len = (short)strlen((char *)sPwd.arr);
strcpy((char *)sConnStr.arr, aHostInfo);
sConnStr.len = (short)strlen((char *)sConnStr.arr);

```

- DB connection

```

if( aCtx != NULL )
{
    EXEC SQL CONTEXT USE :aCtx;
    EXEC SQL CONNECT :sUid IDENTIFIED BY :sPwd USING :sConnStr;
}
else
{
    EXEC SQL CONTEXT USE DEFAULT;
    EXEC SQL CONNECT :sUid IDENTIFIED BY :sPwd USING :sConnStr;
}

```

```
    if(sqlca.sqlcode != 0)
    {
        goto fail_exit;
    }

    return SUCCESS;

fail_exit:

    PRINT_SQL_ERROR("[ERROR] Connection Failure!");

    return FAILURE;
}
```

- DB disconnection

```
int Disconnect(sql_context aCtx)
{
    struct sqlca sqlca;
    if( aCtx != NULL )
    {
        EXEC SQL CONTEXT USE :aCtx;
        EXEC SQL DISCONNECT;
    }
    else
    {
        EXEC SQL CONTEXT USE DEFAULT;
        EXEC SQL DISCONNECT;
    }
    if(sqlca.sqlcode != 0)
    {
        goto fail_exit;
    }

    return SUCCESS;

fail_exit:

    PRINT_SQL_ERROR("[ERROR] Connection Failure!");

    return FAILURE;
}
```

```
}

```

- Create table

```
int CreateEmpTempTable()
{
    EXEC SQL DROP TABLE IF EXISTS EMP_TEMP;
    if(sqlca.sqlcode != 0)
    {
        goto fail_exit;
    }

    EXEC SQL
        CREATE TABLE EMP_TEMP (
            EMPNO NUMBER(4) CONSTRAINT PK_EMP_TEMP PRIMARY KEY,
            ENAME VARCHAR2(10),
            JOB VARCHAR2(9),
            SAL NUMBER(7,2),
            DEPTNO NUMBER(2) );
    if(sqlca.sqlcode != 0)
    {
        goto fail_exit;
    }

    EXEC SQL COMMIT WORK;
    if(sqlca.sqlcode != 0)
    {
        goto fail_exit;
    }
    return SUCCESS;

fail_exit:

    PRINT_SQL_ERROR("[ERROR] SQL ERROR -");
    EXEC SQL ROLLBACK WORK;

    return FAILURE;
}

```

- Drop table

```
int DropEmpTempTable()
{
    EXEC SQL DROP TABLE EMP_TEMP;
    if(sqlca.sqlcode != 0)
    {
        goto fail_exit;
    }

    EXEC SQL COMMIT WORK;
    if(sqlca.sqlcode != 0)
    {
        goto fail_exit;
    }

    return SUCCESS;

fail_exit:

    PRINT_SQL_ERROR("[ERROR] SQL ERROR -");
    EXEC SQL ROLLBACK WORK;

    return FAILURE;
}

void *clientThread(void *args)
{
    EXEC SQL BEGIN DECLARE SECTION;
    SQL_CONTEXT    my_context;
    char          job_name[20 + 1];
    EXEC SQL END DECLARE SECTION;
    int           state = 0;
    thread_param *param = (thread_param *)args;

    EXEC SQL CONTEXT ALLOCATE :my_context;
    state = 1;

    EXEC SQL CONTEXT USE :my_context;
    if(Connect(my_context, "DSN=GOLDILOCKS", "test", "test") != SUCCESS)
    {
        goto fail_exit;
    }
}
```

```
state = 2;

strcpy( job_name, param->mJobName );

EXEC SQL
    INSERT INTO EMP_TEMP
    SELECT *
    FROM   EMP
    WHERE  JOB = :job_name;
if(sqlca.sqlcode != 0)
{
    goto fail_exit;
}

EXEC SQL COMMIT WORK;
if(sqlca.sqlcode != 0)
{
    goto fail_exit;
}
state = 1;
if(Disconnect(my_context) != SUCCESS)
{
    goto fail_exit;
}
state = 0;
EXEC SQL CONTEXT FREE :my_context;
pthread_exit(0);
return NULL;

fail_exit:

PRINT_SQL_ERROR("[ERROR] SQL ERROR -");
switch(state)
{
    case 2:
        (void)Disconnect(my_context);
    case 1:
        EXEC SQL CONTEXT FREE :my_context;
        break;
    default:
        break;
}
```

```

    }

    pthread_exit(0);
    return NULL;
}

```

## Multi-process Application

A multi-process application is an application program which creates and executes multiple processes by using a single process.

GOLDILOCKS embedded SQL does not support a multi-process application. Use a fork function to write a multi-process application. If the application does not execute a new program but continues to executing the existing program after calling the fork function, then be aware of the followings.

- It is difficult to predict which error would occur because the context connected from the parent process is copied to the child process after forking.
- Each OS has a different semaphore management policy. Some OS does not allow both the parent process and child process clear the semaphore created from the parent process.

If writing a multi-process application, then execute forking without any connection. Also, it is required to check the semaphore management policy of the corresponding OS.

## C++ Application

### Extension of Output Filename

Precompiler (gpec) of GOLDILOCKS generates C code by precompiling the embedded SQL source code. The extension of the output file is .c by default. The general C++ source code has various file extensions depending on the compiler types.

-o option which is the output file specification option of gpec is used to specify the file extension. For example, testfile.gc is converted to testfile.cpp as follows.

```
gpec $(GPEC_OPT) testfile.gc -o testfile.cpp
```

### SQLCA\_STORAGE\_CLASS

When the same symbol is declared as a global variable, the conflict on the symbol is occurred in C++ application. The embedded SQL of GOLDILOCKS has the sqlca variable by default, and the conflict of these va



riables causes a problem when linking multiple C++ files.

SQLCA\_STORAGE\_CLASS macro should be defined for all other files except for one file to avoid this problem. For example, if a single application is generated by linking 3 files, SQLCA\_STORAGE\_CLASS macro is defined for two of three files as follows.

```
#define SQLCA_STORAGE_CLASS extern
EXEC SQL INCLUDE SQLCA;
```

SQLCA\_STORAGE\_CLASS macro definition should be positioned ahead of the following statement.

```
EXEC SQL INCLUDE SQLCA;
```

## XA

### Definition of xa\_open string

xa\_open string includes information for connecting to Resource Manager (RM). For more information, refer to **SQLDriverConnect attributes**.

The following is an example of xa\_open string.

```
DSN=GOLDILOCKS;UID=test;PWD=test;CONN_NAME=XA_CONN
```

### Using XA in Precompiler

A user can choose one of the followings when using XA in the precompiler.

- Using the default connection
- Using the named connection

#### Using Default Connection

It uses the connection connected only with the access information in xa\_open string.

The following is an example of xa\_open string for the default connection.

```
DSN=GOLDILOCKS;UID=test;PWD=test
```

It is described as follows when using the embedded SQL with the default connection.

**EXEC SQL**

```

UPDATE Deposit
Set InterestRates = :value :value_ind
WHERE AccountNumber = :account_number;

```



Any connection should not exist in the default context before executing xa open to use XA with the default context.

Do not create multiple XA connections with xa\_open string which does not have CONN\_NAME. When creating multiple connections without CONN\_NAME, then the first created connection is matched with the default context.

## Using Named Connection

It uses the connection name together with the connection information in xa\_open string.

The following is an example of xa\_open string for the named connection.

```
DSN=GOLDILOCKS;UID=test;PWD=test;CONN_NAME=XA_CONN
```

The connection name should be specified as follows in an embedded SQL which uses the named connection.

```

EXEC SQL AT XA_CONN
UPDATE Deposit
Set InterestRates = :value :value_ind
WHERE AccountNumber = :account_number;

```

## Example Program

- GOLDILOCKS Sample - XA

```

#include <stdio.h>
#include <string.h>
#include <stdlib.h>

```

- Include GOLDILOCKS ODBC header

```

#include <goldilocks.h>
EXEC SQL INCLUDE SQLCA;
#define SUCCESS 0
#define FAILURE -1

```

```

#define PRINT_SQL_ERROR(aMsg) \
{ \
    printf("\n"); \
    printf(aMsg); \
    printf("\nSQLCODE : %d\nSQLSTATE : %s\nERROR MSG : %s\n", \
        sqlca.sqlcode, \
        SQLSTATE, \
        sqlca.sqlerrm.sqlerrmc ); \
}

```

- User-specific definitions

```

#define BUF_LEN 101
#define GOLDILOCKS_SQL_THROW( aLabel ) \
    goto aLabel;
#define GOLDILOCKS_SQL_TRY( aExpression ) \
do \
{ \
    if( !(SQL_SUCCEEDED( aExpression ) ) ) \
    { \
        goto GOLDILOCKS_FINISH_LABEL; \
    } \
} while( 0 )
#define GOLDILOCKS_FINISH \
goto GOLDILOCKS_FINISH_LABEL; \
GOLDILOCKS_FINISH_LABEL:

```

- Print diagnostic record to console

```

void PrintDiagnosticRecord( SQLSMALLINT aHandleType, SQLHANDLE aHandle )
{
    SQLCHAR        sSQLState[6];
    SQLINTEGER     sNaiveError;
    SQLSMALLINT    sTextLength;
    SQLCHAR        sMessageText[SQL_MAX_MESSAGE_LENGTH];
    SQLSMALLINT    sRecNumber = 1;
    SQLRETURN      sReturn;
}

```

- SQLGetDiagRec returns the current values which includes an error, warning.

```

while( 1 )
{
    sReturn = SQLGetDiagRec( aHandleType,
                            aHandle,
                            sRecNumber,
                            sSQLState,
                            &sNaiveError,
                            sMessageText,
                            100,
                            &sTextLength );

    if( sReturn == SQL_NO_DATA )
    {
        break;
    }
    GOLDILOCKS_SQL_TRY( sReturn );
    printf("\n=====\\n" );
    printf("SQL_DIAG_SQLSTATE      : %s\\n", sSQLState );
    printf("SQL_DIAG_NATIVE          : %d\\n", sNaiveError );
    printf("SQL_DIAG_MESSAGE_TEXT : %s\\n", sMessageText );
    printf("=====\\n" );
    sRecNumber++;
}
return;
GOLDILOCKS_FINISH;
printf("SQLGetDiagRec failure.\\n" );
return;
}

```

- Create table

```

int testCreateTable()
{
    EXEC SQL AT XA_CONN
        DROP TABLE IF EXISTS DEPOSIT;
    if(sqlca.sqlcode != 0)
    {
        goto fail_exit;
    }
    EXEC SQL AT XA_CONN
        CREATE TABLE DEPOSIT (
            NAME          VARCHAR(30),

```

```

        BALANCE      INTEGER,
        ACCOUNTNUMBER VARCHAR(100),
        ACCOUNTDAY   DATE,
        INTERESTRATES NUMBER(10, 5),
        PHONENUMBER  VARCHAR(30) );
if(sqlca.sqlcode != 0)
{
    goto fail_exit;
}
EXEC SQL AT XA_CONN COMMIT;
if(sqlca.sqlcode != 0)
{
    goto fail_exit;
}
return SUCCESS;
fail_exit:
PRINT_SQL_ERROR("[ERROR] SQL ERROR -");
EXEC SQL AT XA_CONN ROLLBACK;
return FAILURE;
}

```

- Drop table

```

int testDropTable()
{
    EXEC SQL AT XA_CONN
        DROP TABLE DEPOSIT;
    if(sqlca.sqlcode != 0)
    {
        goto fail_exit;
    }
    EXEC SQL AT XA_CONN COMMIT;
    if(sqlca.sqlcode != 0)
    {
        goto fail_exit;
    }
    return SUCCESS;
fail_exit:
PRINT_SQL_ERROR("[ERROR] SQL ERROR -");
EXEC SQL AT XA_CONN ROLLBACK;
return FAILURE;
}

```

```
}

```

- Insert function

```
int testInsert( )
{
    EXEC SQL BEGIN DECLARE SECTION;
    char          sName[BUF_LEN];
    int           sNameInd          = 0;
    int           sBalance          = 0;
    int           sBalanceInd       = 0;
    char          sAccountNumber[BUF_LEN];
    int           sAccountNumberInd = 0;
    DATE          sAccountDay;
    int           sAccountDayInd    = 0;
    double        sInterestRates   = 0;
    int           sInterestRatesInd = 0;
    char          sPhoneNumber[BUF_LEN];
    int           sPhoneNumberInd   = 0;
    EXEC SQL END DECLARE SECTION;

    sNameInd      = sprintf( (char*)sName, BUF_LEN, "sunje" );
    sBalance      = 30000000;
    sAccountNumberInd = sprintf( (char*)sAccountNumber, BUF_LEN, "9999-99-9999" );
    sAccountDay.year      = 2009;
    sAccountDay.month     = 1;
    sAccountDay.day       = 1;
    sAccountDay.hour      = 0;
    sAccountDay.minute    = 0;
    sAccountDay.second    = 0;
    sAccountDay.fraction  = 0;
    sInterestRates       = (double)5.0;
    sPhoneNumberInd      = sprintf( (char*)sPhoneNumber, BUF_LEN, "010-9999-9999" );
    EXEC SQL AT XA_CONN
        INSERT INTO DEPOSIT
        VALUES ( :sName :sNameInd,
                :sBalance :sBalanceInd,
                :sAccountNumber :sAccountNumberInd,
                :sAccountDay :sAccountDayInd,
                :sInterestRates :sInterestRatesInd,
                :sPhoneNumber :sPhoneNumberInd );
    if(sqlca.sqlcode != 0)

```

```

{
    goto fail_exit;
}

```

- The number of rows affected by INSERT statement

```

printf("\n%d row created.\n\n", sqlca.sqlerrd[2] );
    return SUCCESS;
fail_exit:
    PRINT_SQL_ERROR("[ERROR] SQL ERROR -");
    return FAILURE;
}

```

- Update function

```

int testUpdate( )
{
    EXEC SQL BEGIN DECLARE SECTION;
    char    sCondition[BUF_LEN];
    int     sConditionInd    = 0;
    double  sValue          = 0;
    int     sValueInd       = 0;
    EXEC SQL END DECLARE SECTION;
    sValue    = (SQLREAL)6.0;
    sConditionInd = sprintf( (char*)sCondition,
                            BUF_LEN,
                            "9999-99-9999" );

    EXEC SQL AT XA_CONN
        UPDATE Deposit
        Set InterestRates = :sValue :sValueInd
        WHERE AccountNumber = :sCondition :sConditionInd;
    if(sqlca.sqlcode != 0)
    {
        goto fail_exit;
    }
}

```

- The number of rows affected by UPDATE statement

```

printf("\n%d row updated.\n\n", sqlca.sqlerrd[2] );
    return SUCCESS;
fail_exit:
    PRINT_SQL_ERROR("[ERROR] SQL ERROR -");

```

```

    return FAILURE;
}

```

- Select function

```

int testSelect( )
{
    EXEC SQL BEGIN DECLARE SECTION;
    char          sName[BUF_LEN];
    int           sNameInd          = 0;
    int           sBalance          = 0;
    int           sBalanceInd       = 0;
    char          sAccountNumber[BUF_LEN];
    int           sAccountNumberInd = 0;
    DATE          sAccountDay;
    int           sAccountDayInd    = 0;
    double        sInterestRates    = 0;
    int           sInterestRatesInd = 0;
    char          sPhoneNumber[BUF_LEN];
    int           sPhoneNumberInd   = 0;
    EXEC SQL END DECLARE SECTION;
    int           sCount            = 0;
    int           sIsOpen           = 0;
    EXEC SQL DECLARE CUR1 CURSOR FOR
        SELECT NAME, BALANCE, ACCOUNTNUMBER, ACCOUNTDAY, INTERESTRATES, PHONENUMBER
        FROM DEPOSIT;
    EXEC SQL AT XA_CONN
        OPEN CUR1;
    if( sqlca.sqlcode != 0 )
    {
        goto fail_exit;
    }
    sIsOpen = 1;
    printf( "=====\n" );
    while( 1 )
    {
        EXEC SQL AT XA_CONN
            FETCH CUR1 INTO
                :sName :sNameInd,
                :sBalance :sBalanceInd,
                :sAccountNumber :sAccountNumberInd,

```



```
        :sAccountDay :sAccountDayInd,  
        :sInterestRates :sInterestRatesInd,  
        :sPhoneNumber :sPhoneNumberInd;  
if( sqlca.sqlcode == SQL_NO_DATA )  
{  
    break;  
}  
else if( sqlca.sqlcode != 0 )  
{  
    goto fail_exit;  
}  
printf( "NAME          : " );  
if( sNameInd == -1 )  
{  
    printf( "(null)" );  
}  
else  
{  
    printf( "%s", sName );  
}  
printf( "\n" );  
printf( "BALANCE        : " );  
if( sBalanceInd == -1 )  
{  
    printf( "(null)" );  
}  
else  
{  
    printf( "%d", sBalance );  
}  
printf( "\n" );  
printf( "ACCOUNTNUMBER : " );  
if( sAccountNumberInd == -1 )  
{  
    printf( "(null)" );  
}  
else  
{  
    printf( "%s", sAccountNumber );  
}  
printf( "\n" );
```

```

printf( "ACCOUNTDAY   : " );
if( sAccountDayInd == -1 )
{
    printf( "(null)" );
}
else
{
    printf( "%4d-%02d-%02d", sAccountDay.year, sAccountDay.month, sAccountDay.day);
}
printf( "\n" );
printf( "INTERESTRATES : " );
if( sInterestRatesInd == -1 )
{
    printf( "(null)" );
}
else
{
    printf( "%lf", sInterestRates );
}
printf( "\n" );
printf( "PHONENUMBER   : " );
if( sPhoneNumberInd == -1 )
{
    printf( "(null)" );
}
else
{
    printf( "%s", sPhoneNumber );
}
printf( "\n" );
printf( "-----\n" );
sCount ++;
}
printf( "=====\n" );
printf( "\n%d rows selected.\n\n", sCount );
sIsOpen = 0;
EXEC SQL AT XA_CONN
    CLOSE CUR1;
if( sqlca.sqlcode != 0 )
{
    goto fail_exit;
}

```

```

    }
    return SUCCESS;
fail_exit:
    PRINT_SQL_ERROR("[ERROR] SQL ERROR -");
    if( sIsOpen == 1 )
    {
        EXEC SQL AT XA_CONN
            CLOSE CUR1;
    }
    return FAILURE;
}

```

- Delete function

```

int testDelete( )
{
    EXEC SQL BEGIN DECLARE SECTION;
    char    sCondition[BUF_LEN];
    int     sConditionInd      = 0;
    EXEC SQL END DECLARE SECTION;
    sConditionInd = snprintf( (char*)sCondition,
                             BUF_LEN,
                             "9999-99-9999" );

    EXEC SQL AT XA_CONN
        DELETE FROM DEPOSIT WHERE AccountNumber = :sCondition :sConditionInd;
    if( sqlca.sqlcode != 0 )
    {
        goto fail_exit;
    }
}

```

- The number of rows affected by DELETE statement

```

printf("\n%d row deleted.\n\n", sqlca.sqlerrd[2] );
    return SUCCESS;
fail_exit:
    PRINT_SQL_ERROR("[ERROR] SQL ERROR -");
    return FAILURE;
}

```

- Start function

```
int main( int aArgc, char** aArgv )
{
    SQLHENV      sEnv    = NULL;
    SQLINTEGER   sState  = 0;
    xa_switch_t * sXaSwitch;
    XID          sXid;
    sXaSwitch = SQLGetXaSwitch();
```

- If a user calls SQLAllocEnv() which is included in GOLDILOCKS ODBC

```
GOLDILOCKS_SQL_TRY( SQLAllocHandle( SQL_HANDLE_ENV,
                                     NULL,
                                     &sEnv ) );

sState = 1;
```

- SQLSetEnvAttr sets attributes which controls aspects of environments.

```
GOLDILOCKS_SQL_TRY( SQLSetEnvAttr( sEnv,
                                   SQL_ATTR_ODBC_VERSION,
                                   (SQLPOINTER)SQL_OV_ODBC3,
                                   0 ) );

if( (sXaSwitch->xa_open_entry)( "DSN=GOLDILOCKS;UID=test;PWD=test;CONN_NAME=XA_CONN", 0,
TMNOFLAGS ) != XA_OK )
{
    GOLDILOCKS_SQL_THROW( GOLDILOCKS_FINISH_LABEL );
}
sState = 2;
sXid.formatID = 0;
sXid.gtrid_length = 2;
sXid.bqual_length = 1;
memcpy( sXid.data, "100", sXid.gtrid_length + sXid.bqual_length );
```

- Create table

```
if( testCreateTable() != SUCCESS )
{
    GOLDILOCKS_SQL_THROW( GOLDILOCKS_FINISH_LABEL );
}
sState = 3;
if( (sXaSwitch->xa_start_entry)( &sXid, 0, TMNOFLAGS ) != XA_OK )
{
    GOLDILOCKS_SQL_THROW( GOLDILOCKS_FINISH_LABEL );
}
```

```

    }
    sState = 4;

```

- Insert row

```

if( testInsert() != SUCCESS )
{
    GOLDDILOCKS_SQL_THROW( GOLDDILOCKS_FINISH_LABEL );
}

```

- Update row

```

if( testUpdate() != SUCCESS )
{
    GOLDDILOCKS_SQL_THROW( GOLDDILOCKS_FINISH_LABEL );
}

```

- Select row

```

if( testSelect() != SUCCESS )
{
    GOLDDILOCKS_SQL_THROW( GOLDDILOCKS_FINISH_LABEL );
}

```

- Delete row

```

if( testDelete() != SUCCESS )
{
    GOLDDILOCKS_SQL_THROW( GOLDDILOCKS_FINISH_LABEL );
}
sState = 3;
if( (sXaSwitch->xa_end_entry)( &sXid, 0, TMSUCCESS ) != XA_OK )
{
    GOLDDILOCKS_SQL_THROW( GOLDDILOCKS_FINISH_LABEL );
}
if( (sXaSwitch->xa_prepare_entry)( &sXid, 0, TMNOFLAGS ) != XA_OK )
{
    GOLDDILOCKS_SQL_THROW( GOLDDILOCKS_FINISH_LABEL );
}
if( (sXaSwitch->xa_commit_entry)( &sXid, 0, TMNOFLAGS ) != XA_OK )
{
    GOLDDILOCKS_SQL_THROW( GOLDDILOCKS_FINISH_LABEL );
}

```

```

    }
    sState = 2;

```

- Drop table

```

if( testDropTable() != SUCCESS )
{
    GOLDDILOCKS_SQL_THROW( GOLDDILOCKS_FINISH_LABEL );
}
sState = 1;
if( (sXaSwitch->xa_close_entry)( "", 0, TMNOFLAGS ) != XA_OK )
{
    GOLDDILOCKS_SQL_THROW( GOLDDILOCKS_FINISH_LABEL );
}

```

- SQLFreeHandleEnv releases resources related to the environment.

```

sState = 0;
GOLDDILOCKS_SQL_TRY( SQLFreeHandle( SQL_HANDLE_ENV,
                                     sEnv ) );

sEnv = NULL;
return EXIT_SUCCESS;
GOLDDILOCKS_FINISH;
if( sEnv != NULL )
{
    PrintDiagnosticRecord( SQL_HANDLE_ENV, sEnv );
}
switch( sState )
{
    case 4:
        (void)(sXaSwitch->xa_end_entry)( &sXid, 0, TMSUCCESS );
        (void)(sXaSwitch->xa_prepare_entry)( &sXid, 0, TMNOFLAGS );
        (void)(sXaSwitch->xa_commit_entry)( &sXid, 0, TMNOFLAGS );
    case 3:
        (void)testDropTable();
    case 2:
        (void)(sXaSwitch->xa_close_entry)( "", 0, TMNOFLAGS );
    case 1:
        (void)SQLFreeHandle( SQL_HANDLE_ENV, sEnv );
        sEnv = NULL;
    default:
        break;
}

```

```
}  
return EXIT_FAILURE;  
}
```

## 33.4 Embedded SQL Reference

This chapter describes the SQL statements which are available only in the embedded SQL applications of GOLDILOCKS. The embedded SQL statements on the source code should have the following syntax.

```

<statement> ::= EXEC SQL <exec sql statement>;
<exec sql statement> ::=
    <embedded SQL statement>
  | <embedded get group_id statement>
  | <embedded specific statement>
  ;

<embedded SQL statement> ::=
    [ AT <db_name> ] [ ATOMIC ] [ FOR <iteration_count> ] <sql statement>
  ;

<embedded get group_id statement> ::=
    [ AT <db_name> ] <get group_id statement> <sql statement>
<embedded specific statement> ::=
    <autocommit statement>
  | <declare section statement>
  | <include statement>
  | <exception statement>
  | <context statement>
  | <option statement>
  ;

<autocommit statement> ::= [ AT <db_name> ] AUTOCOMMIT { ON | OFF };
<declare section statement> ::= { BEGIN | END } DECLARE SECTION;
<include statement> ::= INCLUDE { SQLCA | <identifier> };
<exception statement> ::= WHENEVER <exception_condition> <exception_action>;
<context statement> ::= CONTEXT <context action>;
<context action> ::=
    ALLOCATE :context_name
  | FREE :context_name
  | USE :context_name
  | USE DEFAULT
  ;

<option statement> ::= OPTION ( <option> );
<get group_id statement> ::= GET GROUPID INTO :group_id;

```



# EXEC SQL AT

## Feature

It specifies the connection name applied to the embedded SQL statement.

## Syntax

```
EXEC SQL [ AT <db_name> ] ...
<db_name> ::=
    <identifier>
  | :hostvar
  ;
```

## Description

The connection name can be specified when connected in the embedded SQL application. The name is used when the embedded SQL statement is performed by using the certain connection.

## Example

```
{
  ...
  EXEC SQL AT :conn_name CONNECT :uid IDENTIFIED BY :pwd USING :conn_str;

  EXEC SQL AT :conn_name
    UPDATE EMP
    SET    sal = sal * 1.1
    WHERE JOB = 'SALES';
  ...
}
```

## For More Information

Refer to [Connection](#).

# EXEC SQL ATOMIC INSERT

## Feature

It performs the atomic array insert.

## Syntax

```
EXEC SQL ATOMIC <insert_statement>;
```

## Description

Atomic array insert is performed in an embedded SQL application. Atomic array insert is for inserting multiple rows at once. It succeeds only when the entire row is inserted. If any row fails to be inserted, the insertion of the entire row is failed.

It has a better performance than the individual insertion because the insertion is performed with a single command.

## Example

```
{  
    EXEC SQL BEGIN DECLARE SECTION;  
    int    emp_number[20];  
    char   emp_name[20][10];  
    int    dept_number[20];  
    EXEC SQL END DECLARE SECTION;
```

- Setting the values of emp\_number, emp\_name, dept\_number

```
...
```

- Inserting the values of emp\_number, emp\_name, dept\_number

```
EXEC SQL ATOMIC INSERT INTO emp (empno, ename, deptno)  
                                VALUES (:emp_number, :emp_name, :dept_number);  
}
```

## For More Information

Refer to **Atomic Insert**.

# EXEC SQL AUTOCOMMIT

## Feature

It changes the autocommit setting.

## Syntax

```
EXEC SQL AUTOCOMMIT { ON | OFF };
```

## Description

It sets the autocommit as follows.

**Table 33-24** Setting the autocommit

Flag	Description
ON	Statement is executed and then autocommit is performed.
OFF	Commit is not performed until the explicit commit statement comes.

## Example

```
{  
  ...  
  EXEC SQL AT :conn_name CONNECT :uid IDENTIFIED BY :pwd USING :conn_str;  
  
  EXEC SQL AUTOCOMMIT ON;  
  EXEC SQL AT :conn_name  
    UPDATE EMP  
    SET    sal = sal * 1.1  
    WHERE JOB = 'SALES';  
  
  ...  
}
```

## For More Information

Refer to [Auto Commit](#).

# EXEC SQL BEGIN DECLARE SECTION

## Feature

It is a precompiler indicator, and it specifies the host variable declaration area.

## Syntax

```
EXEC SQL BEGIN DECLARE SECTION;
```

## Description

It is a precompiler indicator which specifies the host variable declaration section, and it is always used together with EXEC SQL END DECLARE SECTION. When precompiler encounters this statement, it is regarded as the start of declare section, and the variable thereafter is processed as the host variable.

## Example

```
{  
    EXEC SQL BEGIN DECLARE SECTION;  
    int    emp_number[20];  
    char   emp_name[20][10];  
    int    dept_number[20];  
    EXEC SQL END DECLARE SECTION;  
  
    ...  
}
```

## For More Information

Refer to the followings.

- [Declaring Host Variable](#)
- [EXEC SQL END DECLARE SECTION](#)

# EXEC SQL COMMIT RELEASE

## Feature

It commits the transaction and terminates the current connection.

## Syntax

```
EXEC SQL [ AT <db_name> ] COMMIT [ WORK ] RELEASE;
```

## Description

It commits the transaction and terminates the current connection.

```
EXEC SQL AT :conn_name COMMIT RELEASE;
```

The statement above is as same as the following.

```
EXEC SQL AT :conn_name COMMIT;  
EXEC SQL AT :conn_name DISCONNECT;
```

## Example

```
{  
  ...  
  EXEC SQL AT :conn_name CONNECT :uid IDENTIFIED BY :pwd USING :conn_str;  
  
  EXEC SQL AT :conn_name  
    UPDATE EMP  
    SET    sal = sal * 1.1  
    WHERE JOB = 'SALES';  
  EXEC SQL AT :conn_name COMMIT RELEASE;  
  ...  
}
```

## For More Information

Refer to **RELEASE** Option.

# EXEC SQL CONNECT

## Feature

It connects to GOLDILOCKS.

## Syntax

```
EXEC SQL [ AT <db_name> ] CONNECT <user_name> IDENTIFIED BY <password> [ AT <db_name> ] [
USING <conn_string> ]
<db_name> ::=
    <identifier>
    | :hostvar
    ;
<user_name> ::=
    <identifier>
    | :hostvar
    ;
<password> ::=
    <identifier>
    | :hostvar
    ;
<conn_string> ::= :hostvar;
```

## Description

It sets the connection to GOLDILOCKS.

## Example

```
{
    ...
    EXEC SQL CONNECT :uid IDENTIFIED BY :pwd USING :conn_str;
    ...
}
```



## For More Information

Refer to [Connecting to Database](#).

# EXEC SQL CONTEXT ALLOCATE

## Feature

It allocates the run-time context memory.

## Syntax

```
EXEC SQL CONTEXT ALLOCATE :context;
```

## Description

It allocates run-time context memory. It should be allocated for variable of SQL\_CONTEXT type after the variable of SQL\_CONTEXT type is declared in declare section to allocate the run-time context. This statement allocates the memory only, so to use it, USE should be specified and perform the connect.

## Example

```
{
    ...
    EXEC SQL BEGIN DECLARE SECTION;
    SQL_CONTEXT ctxt;
    EXEC SQL END DECLARE SECTION;
    EXEC SQL CONTEXT ALLOCATE :ctxt;

    EXEC SQL CONTEXT USE :ctxt;
    EXEC SQL CONNECT :uid IDENTIFIED BY :pwd USING :conn_str;

    EXEC SQL
        UPDATE EMP
        SET     sal = sal * 1.1
        WHERE  JOB = 'SALES';
    EXEC SQL DISCONNECT;
    EXEC SQL CONTEXT FREE :ctxt;

    ...
}
```

## For More Information

Refer to `SQL_CONTEXT`.

# EXEC SQL CONTEXT FREE

## Feature

It frees the run-time context memory.

## Syntax

```
EXEC SQL CONTEXT FREE :context;
```

## Description

It frees run-time context memory. Disconnect should be performed before freeing the run-time context so that the connection will not be used any more. Otherwise, an unexpected error may occur.

## Example

```
{  
    ...  
    EXEC SQL BEGIN DECLARE SECTION;  
    SQL_CONTEXT ctxt;  
    EXEC SQL END DECLARE SECTION;  
    EXEC SQL CONTEXT ALLOCATE :ctxt;  
  
    EXEC SQL CONTEXT USE :ctxt;  
    EXEC SQL CONNECT :uid IDENTIFIED BY :pwd USING :conn_str;  
  
    EXEC SQL  
        UPDATE EMP  
        SET    sal = sal * 1.1  
        WHERE JOB = 'SALES';  
    EXEC SQL DISCONNECT;  
    EXEC SQL CONTEXT FREE :ctxt;  
  
    ...  
}
```

## For More Information

Refer to `SQL_CONTEXT`.

# EXEC SQL CONTEXT USE

## Feature

It informs the use of run-time context.

## Syntax

```
EXEC SQL CONTEXT USE { :context | DEFAULT };
```

## Description

It is an indicator which informs the precompiler of the use of run-time context, and it specifies the run-time context to be used. The run-time context which is declared and allocated by a user can be used by using SQL\_CONTEXT variable in USE statement, and the default context in the application is used when performing the USE DEFAULT statement.

## Example

```
{  
  ...  
  EXEC SQL BEGIN DECLARE SECTION;  
  SQL_CONTEXT ctxt;  
  double      max_sal;  
  EXEC SQL END DECLARE SECTION;  
  EXEC SQL CONTEXT ALLOCATE :ctxt;  
  
  EXEC SQL CONTEXT USE :ctxt;  
  EXEC SQL CONNECT :uid IDENTIFIED BY :pwd USING :conn_str;  
  
  EXEC SQL  
    UPDATE EMP  
    SET   sal = sal * 1.1  
    WHERE JOB = 'SALES';  
  EXEC SQL COMMIT RELEASE;  
  EXEC SQL CONTEXT FREE :ctxt;  
  
  EXEC SQL CONTEXT USE DEFAULT;  
  EXEC SQL CONNECT :uid IDENTIFIED BY :pwd USING :conn_str;
```

```
EXEC SQL
  SELECT MAX(sal)
  INTO   max_sal
  FROM   EMP
  WHERE  JOB = 'SALES';
EXEC SQL DISCONNECT;
...
}
```

## For More Information

Refer to `SQL_CONTEXT`.

# EXEC SQL DISCONNECT

## Feature

It disconnects from GOLDILOCKS.

## Syntax

```
EXEC SQL [ AT <db_name> ] DISCONNECT [ ALL ]
```

## Description

It disconnects from GOLDILOCKS. A specific connection can be freed with AT clause, and the current connection is freed if AT clause is not used. All connections which are used in the current application are freed by using DISCONNECT ALL.

## Example

```
{  
  ...  
  EXEC SQL AT :conn_name DISCONNECT;  
  ...  
}
```

## For More Information

Refer to [Disconnecting Database](#).



# EXEC SQL END DECLARE SECTION

## Feature

It is a precompiler indicator, and it specifies the the host variable declaration section.

## Syntax

```
EXEC SQL END DECLARE SECTION;
```

## Description

It is a precompiler indicator which specifies the host variable declaration section, and it is always used together with EXEC SQL BEGIN DECLARE SECTION. When precompiler encounters this statement during analyzing the declare section, it is regarded as the end of the declare section.

## Example

```
{  
    EXEC SQL BEGIN DECLARE SECTION;  
    int    emp_number[20];  
    char   emp_name[20][10];  
    int    dept_number[20];  
    EXEC SQL END DECLARE SECTION;  
  
    ...  
}
```

## For More Information

Refer to the followings.

- [Declaring Host Variable](#)
- [EXEC SQL BEGIN DECLARE SECTION](#)

# EXEC SQL FOR

## Feature

It specifies the number of arrays in array operation.

## Syntax

```
EXEC SQL FOR { :array_count | integer_constant } <sql statement>;
```

## Description

If the host variable of the SQL statement is an array, it is a precompiler indicator which specifies the array count. When FOR clause is given, the array count of the host array is ignored and the arrays as many as the number specified in FOR clause are performed.

The constant or variable which refers to array count should be an integer.

## Example

```
EXEC SQL BEGIN DECLARE SECTION;  
int    emp_number[20];  
char   emp_name[20][10];  
int    dept_number[20];  
int    record_cnt;  
EXEC SQL END DECLARE SECTION;
```

- Setting the values of emp\_number, emp\_name, dept\_number

...

- Inserting emp\_number, emp\_name, dept\_number

```
record_cnt = 10;  
EXEC SQL FOR :record_cnt INSERT INTO emp (empno, ename, deptno)  
VALUES (:emp_number, :emp_name, :dept_number);
```

## For More Information

Refer to [Using FOR Clause](#).

# EXEC SQL GET GROUPID INTO

## Feature

It obtains the group ID of the SQL statement.

## Syntax

```
EXEC SQL [ AT <db_name> ] GET GROUPID INTO :group_id { delete_stmt | insert_stmt | select_stmt  
| update_stmt };
```

## Description

It obtains the the group ID of the SQL statement in the cluster environment which uses the global connection. Only the signed numeric type is allowed for the host variable :group\_id. The group ID can be obtained only for the delete, insert, select, update SQL statement, and the shard key should be set in the table in advance.

The SQL statement which obtained the group ID is internally cached in SQLPrepare status without executing SQLExecute.



-1 which is an invalid group ID value can be returned.

## Example

```
{  
EXEC SQL BEGIN DECLARE SECTION;  
int group_id[10];  
int emp_no[10];  
char emp_name[10][20];  
int dept_no[10];  
EXEC SQL END DECLARE SECTION;
```

- Set emp\_no, emp\_name, dept\_no values

...

- Obtain the group id.

```
EXEC SQL GET GROUPID INTO :group_id
        INSERT INTO emp (empno, ename, deptno) VALUES (:emp_no, :emp_name, :dept_no);
```

- INSERT emp\_no, emp\_name, dept\_no.

```
EXEC SQL INSERT INTO emp (empno, ename, deptno) VALUES (:emp_no, :emp_name, :dept_no);
}
```

# EXEC SQL INCLUDE

## Feature

It includes the embedded SQL header file.

## Syntax

```
EXEC SQL INCLUDE <Header file name>;
```

## Description

It includes the embedded SQL header file. If the header file is included with #include of C language, the precompiler does not interpret it, so the precompiler can not recognize it even when the information which the precompiler should recognize such as declare section in the header file is included in it. Therefore, the EXEC SQL INCLUDE statement should be used when the embedded SQL statement which the precompiler should recognize is used.

## Example

```
EXEC SQL INCLUDE decl.h;
```

## For More Information

Refer to [Precompiled Header File](#).

# EXEC SQL INCLUDE SQLCA

## Feature

It includes sqlca.h header file.

## Syntax

```
EXEC SQL INCLUDE SQLCA;
```

## Description

It is a special type of EXEC SQL INCLUDE statement, and it includes sqlca.h header file supported by GOL DILLOCKS. This header file is required for run-time exception handling in the embedded SQL application.

## Example

```
EXEC SQL INCLUDE SQLCA;
```

## For More Information

Refer to [Detecting Run-time Error](#).

# EXEC SQL OPTION

## Feature

It applies the option to the process of precompiling the embedded SQL source code.

## Syntax

```
EXEC SQL OPTION ( <option_desc> );  
<option_desc> ::=  
    INCLUDE = <directory path>  
    ;
```

## Description

It describes the option which is applied to the process of precompiling the embedded SQL source code. It supports only specifying INCLUDE path in the current version, and the option specifies the directory of the header file to be precompiled in EXEC SQL INCLUDE.

## Example

```
EXEC SQL OPTION ( INCLUDE = include );
```

## For More Information

Refer to [Specifying Header File Path](#).



# EXEC SQL ROLLBACK RELEASE

## Feature

It rolls back the transaction, then releases the connection.

## Syntax

```
EXEC SQL [ AT <db_name> ] ROLLBACK [ WORK ] RELEASE;
```

## Description

It rolls back the transaction, then releases the current connection.

```
EXEC SQL AT :conn_name ROLLBACK RELEASE;
```

The statement above is as same as the following.

```
EXEC SQL AT :conn_name ROLLBACK;  
EXEC SQL AT :conn_name DISCONNECT;
```

## Example

```
{  
  ...  
  EXEC SQL AT :conn_name CONNECT :uid IDENTIFIED BY :pwd USING :conn_str;  
  
  EXEC SQL AT :conn_name  
    UPDATE EMP  
    SET    sal = sal * 1.1  
    WHERE JOB = 'SALES';  
  EXEC SQL AT :conn_name ROLLBACK RELEASE;  
  ...  
}
```

## For More Information

3,838 | Embedded SQL

Refer to **RELEASE** Option.

# EXEC SQL WHENEVER

## Feature

It executes run-time exception handling in the embedded SQL application.

## Syntax

```
EXEC SQL WHENEVER <conditions> <actions>;
<conditions> ::=
    SQLERROR
  | SQLWARNING
  | NOT FOUND
  | SQLSTATE <sqlstate class value>[<sqlstate subclass value>]
  ;
<sqlstate_char> ::= [0-9A-Z];
<sqlstate class value> ::= <sqlstate_char> <sqlstate_char>;
<sqlstate subclass value> ::= <sqlstate_char> <sqlstate_char> <sqlstate_char>;
<actions> ::=
    CONTINUE
  | GOTO <label>
  | STOP
  | DO <c statements>
  ;
```

## Description

It automates and processes the run-time exception handling in an embedded SQL application. There are four conditions, a single action can be specified per each condition. The action can be reassigned as needed. For more information, refer to **Handling Implicit Error**.

## Example

```
EXEC SQL WHENEVER SQLERROR STOP;
EXEC SQL WHENEVER SQLERROR CONTINUE;
EXEC SQL WHENEVER SQLERROR GOTO exit_label;
EXEC SQL WHENEVER NOT FOUND DO break;
EXEC SQL WHENEVER SQLERROR GOTO close_label;
EXEC SQL WHENEVER SQLERROR DO sql_error();
```

```
EXEC SQL WHENEVER SQLWARNING CONTINUE;  
EXEC SQL WHENEVER SQLSTATE HY000 DO sql_error();
```

## For More Information

Refer to [Handling Implicit Error](#).

**34.**

---

**PDO**

## 34.1 Overview of PDO

GOLDILOCKS PDO (PDO\_GOLDILOCKS) driver provides PDO interface to access GOLDILOCKS database in PDO, and it is provides in a package.

PDO\_GOLDILOCKS is built based on GOLDILOCKS CLI driver.

## 34.2 Installation /Configuration

### Requirement

The client package of GOLDILOCKS should be installed in the system which is as same as that of PHP, and environment variables of \$GOLDILOCKS\_HOME should be set.

### Installation

#### Installation by Using PECL

Create the package file if PDO\_GOLDILOCKS package file does not exist.

```
% pecl pickle
Attempting to process the second package file
Package PDO_GOLDILOCKS-3.2.0.tgz done
```

Install the package by using PECL if PDO\_GOLDILOCKS package file exists.

```
% sudo -E pecl install PDO_GOLDILOCKS-3.2.0.tgz
```

#### Installation by Building the Source

1. Decompress PDO\_GOLDILOCKS.

```
% tar xvzf PDO_GOLDILOCKS-3.2.0.tgz
% cd PDO_GOLDILOCKS-3.2.0
```

## 2. Create the environment for the build.

Create the build environment for PDO\_GOLDILOCKS expanded module by using `phpize` command.

If `phpize` command can not be found, PHP devel package in an appropriate version should be installed.

```
% whereis phpize
phpize: /usr/bin/phpize /usr/share/man/man1/phpize.1.gz
```

```
% /usr/bin/phpize
Configuring for:
PHP Api Version:      20121113
Zend Module Api No:   20121212
Zend Extension Api No: 220121212
```

## 3. Build it.

Execute `configure` by adding the path of `$GOLDILOCKS_HOME` to `--with-pdo-goldilocks` option and adding the path of `php-config` to `--with-php-config` option, then build it.

```
% whereis php-config
php-config: /usr/bin/php-config /usr/share/man/man1/php-config.1.gz
```

```
% ./configure --with-php-config=/usr/bin/php-config
--with-pdo-goldilocks=/home/goldilocks/goldilocks_home/
```

```
% make
```

## 4. Install it.

```
% sudo -E make install
```

## Altering PHP Configuration File

When using CentOS 6.0 or higher or Fedora 15 or higher, the `pdo_goldilocks.ini` file should be created in `/etc/php.d` directory and extension property should be added as follows.

```
extension=pdo_goldilocks.so
```

When using other OS `extension_dir` should be appropriately set in `php.ini` file and add extension property should be added as follows.

```
extension=pdo_goldilocks.so
```

## Restarting Web Server

Restart the web server.

## Checking Installation of PDO\_GOLDILOCKS

Check whether PDO\_GOLDILOCKS is activated by using `phpinfo()`.

```
% php -i | grep PDO
PDO
PDO support => enabled
PDO drivers => goldilocks, sqlite
PDO Driver for GOLDILOCKS => enabled
PDO Driver for SQLite 3.x => enabled
```

## 34.3 Usage

### Data Source Name (DSN)

Data Source Name (DSN) of PDO\_GOLDILOCKS is configured as follows.

Property	Description
DSN prefix	goldilocks
DSN	ODBC Data Source Name (DSN)
HOST	IP address of a server
PORT	PORT number of server
UID	User ID
PWD	User password



## 34.4 Examples

- Connecting to GOLDILOCKS

```
print "\n[Connecting to GOLDILOCKS]\n";
$db = new PDO('goldilocks:HOST=192.168.0.16;PORT=22581', 'test', 'test');
//$db = new PDO('goldilocks:DSN=GOLDILOCKS;UID=test;PWD=test');
$db->setAttribute(PDO::ATTR_ERRMODE, PDO::ERRMODE_EXCEPTION);
```

- Set test data

```
$result = $db->exec('DROP TABLE IF EXISTS t1');
$result = $db->exec('CREATE TABLE t1 ( id INTEGER GENERATED BY DEFAULT AS IDENTITY, name
VARCHAR(32) )');
$result = $db->exec("INSERT INTO t1(name) VALUES ('Carol')");
$result = $db->exec("INSERT INTO t1(name) VALUES ('Ted')");
$result = $db->exec("INSERT INTO t1(name) VALUES (null)");
$result = $db->exec("INSERT INTO t1(name) VALUES ('William')");
$result = $db->exec("INSERT INTO t1(name) VALUES ('Chelsea')");
$result = $db->exec("INSERT INTO t1(name) VALUES ('Colin')");
$result = $db->exec('DROP TABLE IF EXISTS t2');
$result = $db->exec('CREATE TABLE t2 ( id INTEGER, name VARCHAR(32) )');
$result = $db->exec("INSERT INTO t2 VALUES (1, 'John')");
$result = $db->exec("INSERT INTO t2 VALUES (1, 'John')");
$result = $db->exec("INSERT INTO t2 VALUES (1, 'John')");
$result = $db->exec("INSERT INTO t2 VALUES (2, 'Smith')");
$result = $db->exec("INSERT INTO t2 VALUES (2, 'Smith')");
$result = $db->exec('DROP TABLE IF EXISTS images');
$result = $db->exec('CREATE TABLE images ( id INTEGER, contenttype VARCHAR(256), imagedata
LONG VARBINARY )');
$result = $db->exec('DROP PROCEDURE IF EXISTS sp_out_string');
$result = $db->exec("CREATE OR REPLACE PROCEDURE sp_out_string( v1 OUT VARCHAR(32) ) ".
    "IS ".
    "BEGIN ".
    "  v1 := 'WORLD'; ".
    "END; ");
$result = $db->exec('DROP PROCEDURE IF EXISTS sp_inout_string');
$result = $db->exec("CREATE OR REPLACE PROCEDURE sp_inout_string( v1 INOUT VARCHAR(32) ) ".
    "IS ".
    "BEGIN ";
```

```

        " v1 := V1 || ' WORLD'; ".
        "END; ");

```

- Quoting a normal string

```

print "\n[Quoting a normal string]\n";
$string = 'Nice';
print "Unquoted string: $string\n";
print "Quoted string : " . $db->quote($string) . "\n";

```

- Quoting a dangerous string

```

print "\n[Quoting a dangerous string]\n";
$string = 'Naughty \' string';
print "Unquoted string: $string\n";
print "Quoted string : " . $db->quote($string) . "\n";

```

- Quoting a complex string

```

print "\n[Quoting a complex string]\n";
$string = "Co'mpl' 'ex \'st\'"ring";
print "Unquoted string: $string\n";
print "Quoted string : " . $db->quote($string) . "\n";

```

- Handling an error

```

print "\n[Error Handling]\n";
try
{
    //connect as appropriate as above
    $db->query('invalid query'); //invalid query!
}
catch(PDOException $ex)
{
    print "ERROR:". $ex->getMessage(). "\n";
}

```

- Retrieving column metadata

```

print "\n[Retrieving column metadata]\n";
$stmt = $db->query('SELECT * FROM t1');
foreach(range(0, $stmt->columnCount() - 1) as $column_index)

```

```
{
    $meta = $stmt->getColumnMeta($column_index);
    var_dump($meta);
}
```

- Running simple select statements

```
print "\n[Running Simple Select Statements]\n";
print "\n#1\n";
foreach($db->query('SELECT * FROM t1') as $row)
{
    print $row['ID'].' '.$row['NAME']."\n";
}
print "\n#2\n";
$stmt = $db->query('SELECT * FROM t1');

while($row = $stmt->fetch(PDO::FETCH_ASSOC))
{
    print $row['ID'].' '.$row['NAME']."\n";
}
```

- Fetching rows using different fetch styles

```
print "\n[Fetching rows using different fetch styles]\n";
$stmt = $db->prepare("SELECT id, name FROM t1");
$stmt->execute();
print("PDO::FETCH_ASSOC: ");
print("Return next row as an array indexed by column name\n");
$result = $stmt->fetch(PDO::FETCH_ASSOC);
print_r($result);
print("\n");
print("PDO::FETCH_BOTH: ");
print("Return next row as an array indexed by both column name and number\n");
$result = $stmt->fetch(PDO::FETCH_BOTH);
print_r($result);
print("\n");
print("PDO::FETCH_LAZY: ");
print("Return next row as an anonymous object with column names as properties\n");
$result = $stmt->fetch(PDO::FETCH_LAZY);
print_r($result);
print("\n");
print("PDO::FETCH_OBJ: ");
```

```
print("Return next row as an anonymous object with column names as properties\n");
$result = $stmt->fetch(PDO::FETCH_OBJ);
print $result->NAME;
print("\n");
```

- Fetching rows with a scrollable cursor

```
print "\n[Fetching rows using different fetch styles]\n";
print "\n[Fetching rows with a scrollable cursor]\n";
$sql = 'SELECT id, name FROM t1 ORDER BY id';
print "Reading forwards:\n";
try
{
    $stmt = $db->prepare($sql, array(PDO::ATTR_CURSOR => PDO::CURSOR_SCROLL));
    $stmt->execute();
    while( $row = $stmt->fetch(PDO::FETCH_NUM, PDO::FETCH_ORI_NEXT) )
    {
        $data = $row[0] . "\t" . $row[1] . "\n";
        print $data;
    }
    $stmt = null;
}
catch (PDOException $e)
{
    print $e->getMessage();
}
print "Reading backwards:\n";
try
{
    $stmt = $db->prepare($sql, array(PDO::ATTR_CURSOR => PDO::CURSOR_SCROLL));
    $stmt->execute();
    $row = $stmt->fetch(PDO::FETCH_NUM, PDO::FETCH_ORI_LAST);
    do
    {
        $data = $row[0] . "\t" . $row[1] . "\n";
        print $data;
    } while( $row = $stmt->fetch(PDO::FETCH_NUM, PDO::FETCH_ORI_PRIOR) );
    $stmt = null;
}
catch (PDOException $e)
{
```

```

    print $e->getMessage();
}

```

- Constructing an order

```

print "\n[Construction order]\n";
class Person
{
    private $NAME;
    public function __construct()
    {
        $this->tell();
    }
    public function tell()
    {
        if (isset($this->NAME))
        {
            print "I am {$this->NAME}.\n";
        }
        else
        {
            print "I don't have a name yet.\n";
        }
    }
}

$stmt = $db->query("SELECT name FROM t1");
$stmt->setFetchMode(PDO::FETCH_CLASS, 'Person');
$person = $stmt->fetch();
$person->tell();
$stmt->setFetchMode(PDO::FETCH_CLASS|PDO::FETCH_PROPS_LATE, 'Person');
$person = $stmt->fetch();
$person->tell();

```

- Running simple INSERT, UPDATE, or DELETE statements

```

print "\n[Running Simple INSERT, UPDATE, or DELETE statements]\n";
$affected_rows = $db->exec("INSERT INTO t1(name) VALUES ('John'), ('Marry')");
print $affected_rows." were affected\n";

```

- Getting the last insert id

```
print "\n[Getting the Last Insert Id]\n";
$affected_rows = $db->exec("INSERT INTO t1(name) VALUES ('Smith')");
$insertId = $db->lastInsertId();
print "last insert id : ".$insertId."\n";
```

- Running statements with parameters

```
print "\n[Running Statements With Parameters]\n";
print "\n#1 array\n";
$id = 1;
$name = 'John';
$stmt = $db->prepare("SELECT * FROM t2 WHERE id=? AND name=?");
$stmt->execute(array($id, $name));
$rows = $stmt->fetchAll(PDO::FETCH_ASSOC);
var_dump($rows);
print "\n#2 bindValue\n";
$id = 2;
$name = 'Smith';
$stmt = $db->prepare("SELECT * FROM t2 WHERE id=? AND name=?");
$stmt->bindValue(1, $id, PDO::PARAM_INT);
$stmt->bindValue(2, $name, PDO::PARAM_STR);
$stmt->execute();
$rows = $stmt->fetchAll(PDO::FETCH_ASSOC);
var_dump($rows);
```

- Named placeholders

```
print "\n[Named Placeholders]\n";
print "\n#1 array\n";
$id = 1;
$name = 'John';
$stmt = $db->prepare("SELECT * FROM t2 WHERE id=:id AND name=:name");
$stmt->execute(array(':name' => $name, ':id' => $id));
$rows = $stmt->fetchAll(PDO::FETCH_ASSOC);
var_dump($rows);
print "\n#2 bindValue\n";
$id = 2;
$name = 'Smith';
$stmt = $db->prepare("SELECT * FROM t2 WHERE id=:id AND name=:name");
$stmt->bindValue(':id', $id, PDO::PARAM_INT);
$stmt->bindValue(':name', $name, PDO::PARAM_STR);
```

```
$stmt->execute();
$rows = $stmt->fetchAll(PDO::FETCH_ASSOC);
var_dump($rows);
```

- Executing prepared statements in a loop

```
print "\n[Executing prepared statements in a loop]\n";
$values = array('bob', 'alice', 'lisa', 'john');
$name = '';
$stmt = $db->prepare("INSERT INTO t1(name) VALUES(:name)");
$stmt->bindParam(':name', $name, PDO::PARAM_STR);
foreach($values as $name)
{
    $stmt->execute();
}
foreach($db->query('SELECT * FROM t1') as $row)
{
    print $row[0].' '.$row[1]."\n";
}
```

- Calling a stored procedure with an output parameter

```
print "\n[Calling a stored procedure with an output parameter]\n";
$stmt = $db->prepare("CALL sp_out_string(?)");
$stmt->bindParam(1, $value, PDO::PARAM_STR, 32);
$stmt->execute();
print "procedure returned $value\n";
```

- Calling a stored procedure with an input/output parameter

```
print "\n[Calling a stored procedure with an input/output parameter]\n";
$stmt = $db->prepare("CALL sp_inout_string(?)");
$value = 'HELLO';
$stmt->bindParam(1, $value, PDO::PARAM_STR|PDO::PARAM_INPUT_OUTPUT, 32);
$stmt->execute();
print "procedure returned $value\n";
```

- Transactions

```
print "\n[Transactions]\n";
print "\n#1 commit\n";
try
```

```
{
    $db->beginTransaction();

    $db->exec("INSERT INTO t1(name) VALUES('kim')");
    $name = 'lee';
    $stmt = $db->prepare("INSERT INTO t1(name) VALUES(?)");
    $stmt->execute(array($name));

    $id = 3;
    $name = 'park';
    $stmt = $db->prepare("INSERT INTO t2 VALUES(?, ?)");
    $stmt->execute(array($id, $name));

    $db->commit();
}
catch(PDOException $ex)
{
    //Something went wrong rollback!
    $db->rollBack();
    print $ex->getMessage()."\n";
}
print "\nT1\n";
foreach($db->query('SELECT * FROM t1') as $row)
{
    print $row[0].' '.$row[1]."\n";
}
print "\nT2\n";
foreach($db->query('SELECT * FROM t2') as $row)
{
    print $row[0].' '.$row[1]."\n";
}
print "\n#2 rollback\n";
try
{
    $db->beginTransaction();

    $db->exec("INSERT INTO t1(name) VALUES('KIM')");
    $name = 'LEE';
    $stmt = $db->prepare("INSERT INTO t1(name) VALUES(?)");
    $stmt->execute(array($name));
```



```

$id = 3;
$name = 'PARK';
$stmt = $db->prepare("INSERT INTO invalid VALUES(?, ?)");
$stmt->execute(array($id, $name));

$db->commit();
}
catch(PDOException $ex)
{
    //Something went wrong rollback!
    $db->rollBack();
    print $ex->getMessage()."\n";
}
print "\nT1\n";
foreach($db->query('SELECT * FROM t1') as $row)
{
    print $row[0].' '.$row[1]."\n";
}
print "\nT2\n";
foreach($db->query('SELECT * FROM t2') as $row)
{
    print $row[0].' '.$row[1]."\n";
}

```

- Inserting an image into a database

```

print "\n[Inserting an image into a database]\n";
try
{
    $stmt = $db->prepare("INSERT INTO images (id, contenttype, imagedata) VALUES (?, ?, ?)");
    $id = 1;
    $type = "image/png";
    $fp = fopen("logo.png", "rb");
    $stmt->bindParam(1, $id, PDO::PARAM_INT);
    $stmt->bindParam(2, $type, PDO::PARAM_STR, 256);
    $stmt->bindParam(3, $fp, PDO::PARAM_LOB);
    $db->beginTransaction();
    $stmt->execute();
    $db->commit();
}
catch(PDOException $ex)

```

```

{
    $db->rollBack();
    print $ex->getMessage()."\n";
}
foreach($db->query('SELECT id, contenttype, lengthb(imagedata) FROM images') as $row)
{
    print $row[0].' '.$row[1].' '.$row[2]."\n";
}

```

- Displaying an image from a database

```

print "\n[Displaying an image from a database]\n";
try
{
    $stmt = $db->prepare("SELECT contenttype, imagedata FROM images WHERE id = ?");
    $id = 1;
    $stmt->execute(array($id));
    $stmt->bindColumn(1, $type, PDO::PARAM_STR, 256);
    $stmt->bindColumn(2, $lob, PDO::PARAM_LOB);
    $stmt->fetch(PDO::FETCH_BOUND);
    print 'Content-Type: '.$type."\n";
    print 'size: '.file_put_contents($id.".png", $lob)."\n";
}
catch(PDOException $ex)
{
    print $ex->getMessage()."\n";
}

```

**35.**

---

**PyDBC**

## 35.1 GOLDDILOCKS PyDBC

### Overview

PyDBC programs Python accessing GOLDDILOCKS database by using API which complies with **Python Database API Specification v2.0(PEP 249)**.

PyDBC requires the Python standard library, and the internal operation which connects to and operate GOLDDILOCKS database requires ODBC library because it calls ODBC API. PyDBC uses `gdlds` in ODBC library `$GOLDDILOCKS_HOME/lib` by default, and the user can modify it by updating `setup.py`.

The internal operation of PyDBC uses ODBC driver, so it is as same as **Overview of ODBC Components**. There are an architecture of which an application links to the driver manager, and an architecture of which an application links to GOLDDILOCKS ODBC driver library.

### Version

The information of GOLDDILOCKS PyDBC version can be viewed by executing `pygoldilocks.so` file as follows.

```
shell>python
>>> import pygoldilocks
>>> print pygoldilocks.version
3.2.0
```

The current version of GOLDDILOCKS PyDBC driver is 3.2.0 according to GOLDDILOCKS version, and this driver complies with the standard Python database API 2.0. PyDBC driver supports Python 2.7, 3.4, 3.5, 3.6 versions, and PyDBC driver library should be installed according to each Python version.

### Installation

The source should be built to install PyDBC. PyDBC links `gdlds` library in `GOLDDILOCKS_HOME/lib` and it includes `goldilocks.h` header file in `GOLDDILOCKS_HOME/include`, so the environment variable `GOLDDILOCKS_HOME` should be set in an appropriate position.

When installing PyDBC, the bit of Python should be as same as that of GOLDDILOCKS library. Therefore, if GOLDDILOCKS is built in 32 bit, then PyDBC should be installed by using Python 32 bit.

## Installation on Linux

Linux requires the gcc compiler, and it is built as follows.

```
shell> sudo python setup.py install
```



It does not support HP-UX nor AIX platform.

## Installation on Windows

It is built on Windows as follows.

```
shell> python setup.py install
```

An appropriate Microsoft Visual C++ compiler according to python version is required to compile PyDBC. For more information, refer to <https://wiki.python.org/moin/WindowsCompilers>.

- Visual Studio 2003.NET compiler is required to build Python version 2.4 or 2.5, and there is not a free ware for this version.
- Visual C++ 2008 compiler is required to build Python version 2.6, 2.7, 3.0, 3.2, and the freeware for this version is Visual C++ 2008 Express.
- Visual C++ 2010 compiler is required to build Python version 3.3, 3.4, and the freeware for this version is Visual C++ 2010 Express.
- Visual C++ 2014 or VC 2017 compiler is required to build Python version 3.5, 3.6.
- Visual C++ 2017 compiler is required to build Python version 3.7.

## Examples

### Obtaining Connection Class

PyDBC implicitly calls ODBC library. Therefore, **the data source** should be configured to obtain the connection.

- Obtain the connection as follows.

```
import pygoldilocks
cnxn = pygoldilocks.connect( 'DSN=GOLDDILOCKS;UID=test;PWD=test' )
```

Call connect which is an internal function of pygoldilocks, a module of PyDBC, to obtain the connection.



**Data Source** should be configured in advance to use DSN.

If CHARSET is not set in DSN, then ODBC library sets it to Console Character Set. PyDBC implicitly performs the basic encoding for the character set used by ODBC. If the character set used in GOLDILOCKS server is different from that in ODBC library, then the data conversion occurs and it degrades the performance. For example, CP949 is used as a basic character set in Windows. If nothing is set, PyDBC implicitly uses CP949(UHC) when encoding, and ODBC library also uses UHC when processing the character set.

The followings are how to alter the character set of the client.

- Alter CHARSET property in **Data Source Configuration**.
- Add CHARSET property to the connection string.
- Use `attrs_before` keyword in connect method of `pygoldilocks` module.

All of the three methods above alter the connection property of ODBC, `SQL_ATTR_CHARACTER_SET`, and set the encoding of PyDBC library as well.

## Using Cursor and Row Class

A cursor and a row class can be used as follows.

```
cursor = cnxn.cursor()
cursor.execute( "SELECT NAME, ADDRESS FROM EMP" )
rows = cursor.fetchall()
for row in rows:
    print row.A, row.B
cursor.close()
cnxn.close()
```

## 35.2 API Reference

### pygoldilocks Module

pygoldilocks object complies with **Python Database API Specification v2.0**.

For more information, refer to **Python DB API module**.

### Properties

- version
  - The version of pygoldilocks module follows that of GOLDDLOCKS database. The version is a string in a form of major.minor.patch.
- apilevel
  - It indicates DB API level 2.0, and the value is "2.0" character string constant.
- lowercase
  - It controls whether to convert the column name from the row object of the result value to lowercase. The default value is false. It is useful when the case of database column does not conform.
- threadsafety
  - It is constant 1, and it does not share the connection even when threads share the module.
- paramstyle
  - It indicates a parameter and the value is the character string constant "qmark" which means a question mark.

### connect

It newly connects to the database.

```
connect( *connectionstring, **kwargs )
```

It inputs the ODBC connect string and keywords. The keywords are as follows.

Keyword	Description	Default value
attrs_before	It sets properties which should be set before the connection. It receives the value in dictionary type.	-
autocommit	It sets whether to auto commit. If it is false, connection.commit should be called to reflect it in the database.	False

Keyword	Description	Default value
readonly	If it is true, the connection is set to readonly.	False
timeout	It sets the timeout for the connection. <code>SQL_ATTR_LOGIN_TIMEOUT</code> is set.	-

- `attrs_before`
  - It sets options which is to be set before the connection. These options are set by using `SQLSetConnectAttr`. It receives the properties and values in dictionary type. For more information about configuration, refer to **ODBC attributes**.

```
cnxn = pygoldilocks.connect( "DSN=GOLDILOCKS", attr_before={ pygoldilocks.SQL_ATTR_MAX_ROWS :
1000 })
```

## Date

```
>>> print pygoldilocks.Date(1984,11,23), type(pygoldilocks.Date(1984,11,23))
1984-11-23 <type 'datetime.date'>
```

It creates a date object corresponding to the given value.

## Time

```
>>> print pygoldilocks.Time(11,23,23), type(pygoldilocks.Time(11,23,23))
11:23:23 <type 'datetime.time'>
```

It creates a time object corresponding to the given value.

## Timestamp

```
>>> print pygoldilocks.Timestamp(1984,11,23,11,23,23),
type(pygoldilocks.Timestamp(1984,11,23,11,23,23))
1984-11-23 11:23:23 <type 'datetime.datetime'>
```

It creates a datetime object corresponding to the given value.

## DATETIME

```
>>> print pygoldilocks.DATETIME(1984,11,23,11,23,23),
type(pygoldilocks.DATETIME(1984,11,23,11,23,23))
1984-11-23 11:23:23 <type 'datetime.datetime'>
```



It creates a datetime object corresponding to the given value. It is as same as **Timestamp**.

## Binary

```
>>> print pygoldilocks.Binary('binary'), type(pygoldilocks.Binary('binary'))  
binary <type 'bytearray'>
```

It creates a bytearray object corresponding to the given value. It is as same as **BINARY**.

## BINARY

```
>>> print pygoldilocks.BINARY('binary'), type(pygoldilocks.BINARY('binary'))  
binary <type 'bytearray'>
```

It creates a bytearray object corresponding to the given value.

## STRING

```
>>> print pygoldilocks.STRING('str'), type(pygoldilocks.STRING('str'))  
str <type 'str'>
```

It creates an str object corresponding to the given value.

## NUMBER

```
>>> print pygoldilocks.NUMBER(100.001), type(pygoldilocks.NUMBER(100.001))  
100.001 <type 'float'>
```

It creates a float object corresponding to the given value.

## ROWID

```
>>> print pygoldilocks.ROWID('AA'), type(pygoldilocks.ROWID('AA'))  
AA <type 'str'>
```

It is used to describe the row ID column of the database, and returns an str object.

## TimeFromTicks

```
>>> print pygoldilocks.TimeFromTicks( 10 )  
09:00:10
```

It returns a `datetime.time` object which is set as an argument value.

## DateFromTicks

```
>>> print pygoldilocks.DateFromTicks( 360000 )  
1970-01-05
```

It returns a `datetime.date` object which is set as an argument value.

## TimestampFromTicks

```
>>> print pygoldilocks.DateFromTicks( 360000 )  
1970-01-05
```

It returns a `datetime.timestamp` object which is set as an argument value.

## setDecimalSeparator

It sets the decimal point delimiter in NUMERIC type obtained from the database. The default value uses a period (.).

## getDecimalSeparator

It obtains the set decimal point delimiter in NUMERIC type.

## Connection

It is an object managing the connection with the database, and it is created with `connect()` function of `pygoldilocks` module.

## Properties

- `autocommit`
  - It can set the autocommit mode of the connection.
- `searchescape`
  - It obtains an escape character of ODBC. `pygoldilocks` uses `'/'`.
- `timeout`
  - It sets `SQL_ATTR_QUERY_TIMEOUT` by using `SQLSetConnectAttr` function.

## 함수

- `cursor()`
  - It returns a new cursor object.
- `commit()`
  - It commits the executed SQL statement.
- `rollback()`
  - It rolls back the executed SQL statement.
- `close()`
  - It closes the connection. If the autocommit is false, then the SQL statement which was not committed is rolled back.
- `getinfo( info )`
  - It can obtain the connection properties by using `SQLGetInfo` function of ODBC. For more information, refer to **SQLGetInfo**.

```
dns_name = cnxn.getinfo( pygoldilocks.SQL_DATA_SOURCE_NAME )
```

- `execute( sql, [*params] )`
  - It creates a new cursor object, and executes `execute` function of this object, then returns a cursor object.

```
cursor = cnxn.execute( "SELECT COUNT(*) FROM EMP" )
```

For more information, refer to `Cursor.execute()` function. This function does not exist in Python API, but it is provided for the convenience. Whenever this function is called, a cursor object is allocated, so it is not recommended to use it when it is required to execute one or more SQL statements.

- `set_attr( attr_id, value )`

- The connection properties can be set by executing `SQLSetConnectAttr` function.
- The following is an example of controlling the transaction isolation level of the database by using `set_attr` function.

```
connection.set_attr( pygoidilocks.SQL_ATTR_TXN_ISOLATION, pygoidilocks.SQL_TXN_SERIALIZABLE )
```

## Cursor

Generally, a cursor object means the database cursor which is used to manage the fetch operation. The database cursor is mapped to ODBC statement handle (HSTMT). The cursor objects which is created by the same connection are not separated. In other words, all updates executed by a cursor to the database are also applied to other cursors.



Cursor does not manage the database transaction, but the connection commits or rolls back the transaction.

## Properties

### Description

It is the read-only property, and it includes the contents for each column which was returned by `SELECT` statement executed last with tuple type. Each tuple includes the followings.

1. Column name (or alias)
2. Type code
3. Display size
4. Internal size
5. Precision
6. Scale
7. Nullable

When `SELECT` statement is not called, then the description is none.

### rowcount

It is the number of rows which were updated by SQL statement which was executed last.

## arraysize

It is the number of rows which can be fetched per one time by using `fetchmany( [size = cursor.arraysize] )` function. The default value 1.

## connection

It is the read-only property, and it indicates the connection object which created the corresponding cursor object.

## fast\_executemany

If it is set to true, then makes the parameters in array and executes them at once when executing `execute many( sql, [*params] )` function. If it is set to false, it separately executes each parameter.

## Function

### execute( sql, [\*params] )

It executes SQL statement through `SQLPrepare` and `SQLExecute` functions, then returns a cursor which called this function.

The parameter option can be used as follows.

```
cursor.execute( "SELECT A FROM TEST WHERE B=? AND C=?", x, y )
```

```
cursor.execute( "SELECT A FROM TEST WHERE B=? AND C=?", (x, y) )
```

### executemany( sql, [\*params] )

It executes SQL statement for each parameter and returns *none*. Parameter *params* should be a sequence type of a sequence or a sequence generator.

```
params = [ ( 1, 'A' ), ( 2, 'B' ) ]
cursor.executemany("INSERT INTO TEST( C1, C2 ) VALUES ( ?, ? )", params)
```

SQL statement is executed twice in the example above. In other words, it is separately executed for ( 1, 'A' ) and ( 2, 'B' ) each. The operation of `executemany` depends on whether `fast_executemany` of a cursor object is set to true or false.

The example above is as same as follows.

```
params = [ ( 1, 'A' ), ( 2, 'B' ) ]
for p in params:
    cursor.execute( "INSERT INTO TEST( C1, C2 ) VALUES ( ?, ? )", p )
```

If `fast_executemany` is set to `true`, `executemany` processes the operation with only a single `execute`. For that, data in the same index location in items of parameter `params` should be the same data type.

```
params = [ ( 1, 'A' ), ( '2', 'B' ) ]
cursor.executemany("INSERT INTO TEST( C1, C2 ) VALUES ( ?, ? )", params)
```

In the example above, the data type of the first item among two items of parameter `params` is different. Likewise, the data type on the same index location between items are different, then `executemany` does not process SQL statement at once, but separately processes it.

If the `autocommit` of a connection object is `true`, then SQL statement is processed being split and each SQL statement is separately committed. If an error occurs while sequentially processing records, then only some records are committed to the database and the operation is completed leaving some records are not committed. Therefore, it is recommended to set `autocommit` to `false` to check if all records are committed to the database when using `executemany()`.

## fetchone()

It returns the next row of the query. If the next data does not exist, it is `none`.

## fetchall()

It returns all rows left in the query. Be cautious when using it because it reads all rows to the memory.

## fetchmany( [size = cursor.arraysize] )

It returns rows which were left as many as `size` or `cursor.arraysize`. The next data returns an empty sequence data. The default value of `cursor.arraysize` is 1.

## commit()

It commits SQL statement. It is a function executed by a connection object which created a cursor object, and it is applied to all cursor which were created in the same connection object. It is as same as `commit` of the connection object.

## rollback()

It rolls back SQL statement. It is a function executed by a connection object which created a cursor object, and it is applied to all cursor which were created in the same connection object. It is as same as `rollback` of the connection object.

## skip( count )

It passes through the record through `SQLFetchScroll` and `SQL_FETCH_NEXT` as many times as it is set in `count`.

## nextset()

It returns false because GOLDILOCKS ODBC does not support SQLMoreResults.

## close()

It closes a cursor object.

## setinputsizes( size\_list )

It is an optional function, and receives sequence type as a parameter. It sets INPUT parameter size of SQL BindParameter.

## setoutputsize( size )

It is an optional function, and is used for a purpose which is different from that of DB API, and it allocates the buffer size of OUTPUT parameter.

## callproc( procname [, params] )

It calls the storage procedure corresponding to procname. The parameter should be a sequence type, and it includes the output parameter. However, data located in the output parameter when inputting is meaningless. callproc function updates data corresponding to INOUT, OUT of the input parameter data, and returns it in sequence type.

```

create_proc = """CREATE OR REPLACE PROCEDURE PROC1( A1 INTEGER, A2 OUT CHAR(10) )
IS
  V1 CHAR(10);
BEGIN
  SELECT T1.I1
  INTO V1
  FROM T1
  WHERE T1.I1 >= A1 AND T1.I1 <= A1;
  A2 := V1;
END;\
"""

cursor.execute( create_proc )
result = cursor.callproc( 'PROC1', ( 1, 0 ) )

```

## callfunc( funcname [, params] )

It calls a function corresponding to funcname. callfunc() returns the function data.

```

create_func = """
CREATE OR REPLACE FUNCTION FUNC1( A1 INTEGER, A2 INTEGER )
RETURN INTEGER
IS
  V1 INTEGER;
BEGIN
  SELECT COUNT(*)
  INTO V1
  FROM T1
  WHERE T1.I1 >= A1 AND T1.I1 <= A2;
RETURN V1;
END;\
"""
cursor.execute( create_func )
cursor.commit()
result = cursr.callfunc( 'FUNC1', ( 1, 4) )

```

### tables( table=None, catalog=None, schema=None, tableType=None )

It returns the table information of the database which satisfies the given condition. The character '\_' and '%' are translated as a wild card. Each row has the following column information. For more information, refer to [SQLTables](#).

1. table\_cat: It is the name of the catalog.
2. table\_schem: It is the name of the schema.
3. table\_name: It is the name of the table.
4. table\_type: 'TABLE', 'VIEW', 'SYSTEM TABLE', 'GLOBAL TEMPORARY', 'LOCAL TEMPORARY', 'IMMUTABLE TABLE', 'ALIAS', 'SYNONYM' or a specific type name can be a table type.
5. remarks: It is a description of a table.

```

print cursor.tables( table= 'TEST' ).fetchone()
#print table name
for row in cursor.tables():
  print row.table_name

```



If a parameter is empty, information of all table of which a user has a privilege is returned.

### columns( table=None, catalog=None, schema=None, tableType=None )

It obtains the column information of the specified table through [SQLColumns](#) function. Each row includes the following column information.



1. table\_cat
2. table\_schem
3. table\_name
4. column\_name
5. data\_type
6. type\_name
7. column\_size
8. buffer\_length
9. decimal\_digits
10. num\_prec\_radix
11. nullable
12. remarks
13. column\_def
14. sql\_data\_type
15. sql\_datetime\_sub
16. char\_octet\_length
17. ordinal\_position
18. is\_nullable: SQL\_NULLABLE, SQL\_NO\_NULLS or SQL\_NULLS\_UNKNOWN.

```
#print column name of table TEST
for r in cursor.columns( table = 'TEST' ):
    print r.column_name
```

### **statistics( table, catalog=None, schema=None, unique=False, quick=True )**

It obtains the information about the specified table through `SQLStatistics` function.

If `unique` is true, it returns an unique index, and if it is false, it returns all indexes.

If `quick` is true, `CARDINALITY` and `PAGES` are returned only when it is instantly available, otherwise, `NULL` is returned to the corresponding column.

1. table\_cat
2. table\_schem
3. table\_name
4. non\_unique
5. index\_qualifier
6. index\_name
7. type
8. ordinal\_position
9. column\_name
10. asc\_or\_desc
11. cardinality
12. pages

## 13. filter\_condition



A wildcard character is not allowed.

### **rowIdColumns( table, catalog=None, schema=None, nullable=True )**

It returns the result set of columns which uniquely identifies a row by executing **SQLSpecialColumns** with **SQL\_BEST\_ROWID**. Each row includes the following column information.

1. scope: **SQL\_SCOPE\_CURROW**, **SQL\_SCOPE\_TRANSACTION**, or **SQL\_SCOPE\_SESSION**
2. column\_name
3. data\_type: SQL type constant of ODBC
4. type\_name
5. column\_size
6. buffer\_length
7. decimal\_digits
8. pseudo\_column: **SQL\_PC\_UNKNOWN**, **SQL\_PC\_NOT\_PSEUDO** or **SQL\_PC\_PSEUDO**

### **rowVerColumns( table, catalog=None, schema=None, nullable=True )**

It returns the result set of columns which are automatically updated when a row is updated by executing **SQLSpecialColumns** with **SQL\_ROWVER**. Each row includes the following column information.

1. scope: **SQL\_SCOPE\_CURROW**, **SQL\_SCOPE\_TRANSACTION**, or **SQL\_SCOPE\_SESSION**
2. column\_name
3. data\_type: SQL type constant of ODBC
4. type\_name
5. column\_size
6. buffer\_length
7. decimal\_digits
8. pseudo\_column: **SQL\_PC\_UNKNOWN**, **SQL\_PC\_NOT\_PSEUDO**, or **SQL\_PC\_PSEUDO**

### **primaryKeys( table, catalog=None, schema=None )**

It returns the result set of columns which configures major keys of a table by executing **SQLPrimaryKeys** function. Each row includes the following column information.

1. table\_cat
2. table\_schem
3. table\_name
4. column\_name
5. key\_seq
6. pk\_name

## **foreignKeys( table=None, catalog=None, schema=None, foreignTable=None, foreignCatalog=None, foreignSchema=None )**

It creates the result set of column names of a specified table, or the result set of column names which are foreign keys of another table referring to the basic key of the specified table, by executing **SQLForeignKey** function. Each row includes the following column information.

1. pktable\_cat
2. pktable\_schem
3. pktable\_name
4. pkcolumn\_name
5. fktable\_cat
6. fktable\_schem
7. fktable\_name
8. fkcolumn\_name
9. key\_seq
10. update\_rule
11. delete\_rule
12. fk\_name
13. pk\_name
14. deferrability

## **procedures( procedure=None, catalog=None, schema=None )**

It creates the result set of the information about the procedure by executing **SQLProcedures**. Each row includes the following column information.

1. procedure\_cat
2. procedure\_schem
3. procedure\_name
4. num\_input\_params
5. num\_output\_params
6. num\_result\_sets
7. remarks
8. procedure\_type

## **getTypeInfo( sqlType=None )**

It creates the result set of the information about the specified data type or about all data types which are supported by GOLDILOCKS ODBC, by executing **SQLGetTypeInfo** function. Each row includes the following column information.

1. type\_name

2. data\_type
3. column\_size
4. literal\_prefix
5. literal\_suffix
6. create\_params
7. nullable
8. case\_sensitive
9. searchable
10. unsigned\_attribute
11. fixed\_prec\_scale
12. auto\_unique\_value
13. local\_type\_name
14. minimum\_scale
15. maximum\_scale
16. sql\_data\_type
17. sql\_datetime\_sub
18. num\_prec\_radix
19. interval\_precision

## Row

A row object is returned with fetch function of a cursor object. It is processed as a tuple type as described in DB API.

```
row = cursor.fetchone()
for column in row:
    print column
```

The following features are added to pygoldilocks.

- It can access the data by using a column name.
- It can access the value of cursor.description through a row even after a cursor object is closed.
- It can update the value of a row.

Accessing to a row by using a column name is not only convenient but it also improves the readability. However, if a column name includes Python reserved name or a whitespace, then it be accessed only through row.\_\_getattr\_\_().

```
cursor.execute( "select c1 from test")
print cursor.description
```

```
row = cursor.fetchone()
print row.C1
```

```
(('C1', <type 'str'>, 10, 10, 10, 0, True),)
test
```



Basically, the identifier of GOLDILOCKS database is uppercase. However, sometimes it is required to be specified in lowercase, so be cautious of using uppercase or lowercase when accessing to a row by using a column name.

## Properties

- `cursor_description`

It is the copy of property description of a cursor object which created the corresponding row. For more information, refer to **Cursor.description**.

## 35.3 Exception

Python exceptions occur by pygoldilocks when GOLDILOCKS ODBC detects an error. The exception classes are as follows, which are the same as **Python DB API**.

- Error
  - DatabaseError
    - DataError
    - OperationalError
    - IntegrityError
    - InternalError
    - ProgrammingError
    - NotSupportedError

If an error occurs, generally, the exception is processed based on SQLSTATE value provided by the database.

SQLSTATE	Exception
0A000	NotSupportedError
01002	OperationalError
08001	OperationalError
08003	OperationalError
08004	OperationalError
08007	OperationalError
08S01	OperationalError
28000	InterfaceError
40002	IntegrityError
22***	DataError
23***	IntegrityError
24***	ProgrammingError
25***	ProgrammingError
42***	ProgrammingError

## 35.4 Data Type

### Transferring Python Parameter to GOLDILOCKS

The data is converted as follows when transferring Python parameter to GOLDILOCKS ODBC.

**Table 35-1** Python 3

Python datatype	Description	ODBC datatype
None	-	SQL_VARCHAR
str	UTF-8	SQL_VARCHAR or SQL_LONGVARCHAR
bytes, bytearray	binary	SQL_VARBINARY or SQL_LONGVARBINARY
bool	bit	SQL_BIT
datetime.date	date	SQL_TYPE_DATE
datetime.time	time	SQL_TYPE_TIME
datetime.datetime	timestamp	SQL_TYPE_TIMESTAMP
int	integer	SQL_BIGINT
float	floating point	SQL_DOUBLE
decimal	numeric	SQL_NUMERIC

**Table 35-2** Python 2

Python datatype	Description	ODBC datatype
None		SQL_VARCHAR
str	UTF-8	SQL_VARCHAR or SQL_LONGVARCHAR
bytearray	binary	SQL_VARBINARY or SQL_LONGVARBINARY
buffer	binary	SQL_VARBINARY or SQL_LONGVARBINARY
bool	bit	SQL_BIT
datetime.date	date	SQL_TYPE_DATE
datetime.time	time	SQL_TYPE_TIME
datetime.datetime	timestamp	SQL_TYPE_TIMESTAMP
int	integer	32 bit: SQL_INTEGER, 64 bit: SQL_BIGINT
long	bigint	SQL_BIGINT
float	floating point	SQL_DOUBLE
decimal	numeric	SQL_NUMERIC

## SQL Value Received from GOLDILOCKS

The data is converted as follows when transferring the data of GOLDILOCKS database to Python.

**Table 35-3** Python 3

ODBC datatype	Description	Python datatype
any	NULL	None
SQL_CHAR, SQL_VARCHAR, SQL_LONGVARCHAR	text	text
SQL_BINARY, SQL_VARBINARY, SQL_LONGVARBINARY	binary	bytes
SQL_NUMERIC	decimal, numeric	decimal.Decimal
SQL_BOOLEAN	bit, bool	bool
SQL_SMALLINT, SQL_INTEGER	integers	int
SQL_BIGINT	long	long
SQL_REAL, SQL_FLOAT, SQL_DOUBLE	floating point	float
SQL_TYPE_TIME	time	datetime.time
SQL_TYPE_DATE	date	datetime.date
SQL_TYPE_TIMESTAMP	timestamp	datetime.timestamp
SQL_TYPE_TIME_WITH_TIMEZONE	time with timezone	text
SQL_TYPE_TIMESTAMP_WITH_TIMEZONE	timestamp with timezone	text
SQL_C_INTERVAL_***	interval	text

**Table 35-4** Python 2

ODBC datatype	Description	Python datatype
any	NULL	None
SQL_CHAR, SQL_VARCHAR, SQL_LONGVARCHAR	text	text
SQL_BINARY, SQL_VARBINARY, SQL_LONGVARBINARY	binary	bytes
SQL_NUMERIC	decimal, numeric	decimal.Decimal
SQL_BOOLEAN	bit, bool	bool
SQL_SMALLINT, SQL_INTEGER	integers	int
SQL_BIGINT	long	long
SQL_REAL, SQL_FLOAT, SQL_DOUBLE	floating point	float
SQL_TYPE_TIME	time	datetime.time
SQL_TYPE_DATE	date	datetime.date
SQL_TYPE_TIMESTAMP	timestamp	datetime.timestamp
SQL_TYPE_TIME_WITH_TIMEZONE	time with timezone	text
SQL_TYPE_TIMESTAMP_WITH_TIMEZONE	timestamp with timezone	text
SQL_C_INTERVAL_***	interval	text

The text of Python data type is converted to unicode in Python 3. It is converted to the unicode or a string according to the character set of the database in Python 2.



**Table 35-5** Python 2 text

DB character set	Python type
UTF-8	str
SQL_ASCII	str
UHC	unicode
GB18030	unicode



**36.**

---

## **Hibernate**

## 36.1 Overview

Hibernate is a Object-Relational Mapping (ORM) framework of which Java Persistent API (JPA) model is applied to the database. It maps the relationship between DB table and Java object so that it helps the persistent logic processing. In other words, when using hibernate, it is easy to access and control DB without using SQL.

## 36.2 Interworking with Hibernate

### Downloading Hibernate

Hibernate can be downloaded at <https://sourceforge.net/projects/hibernate/>. When the downloaded file is decompressed, many jar files are found in lib directory. These files are used to interwork with hibernate.



Hibernate of GOLDBLOCKS is created based on Hibernate version 5.2.

### Interworking with GoldilocksDialect Class

GOLDBLOCKS provides GoldilocksDialect.java file which is appropriate to Hibernate ORM version. When using Goldilocks.java 5 version file in Hibernate ORM 4 version, then a compile error occurs. Therefore, use GoldilocksDialect.java file which is appropriate for Hibernate version.

Especially, Hibernate ORM 4 version provides each different api according to the patch version, so GOLDBLOCKS provides GoldilocksDialect.java according to it. For example, Goldilocks.java 4.0.0 version is used in Hibernate ORM 4.1.4 version, and GoldilocksDialect.java 4.1.5 version is used in Hibernate ORM 4.1.9 version.

GOLDBLOCKS provides GoldilocksDialect.java in the directory under \$GOLDBLOCKS\_HOME/app\_dev/Hibernate/.

## Porting to Hibernate jar File

It should be ported to the downloaded Hibernate jar file to interwork with Hibernate. `GoldilocksDialect.class` file and `GoldilocksDialect$1.class` file can be included in Hibernate jar file as follows.

1. Create a class file by compiling `GoldilocksDialect.java` file using `javac`. (The class file is differently created per each version.)
2. Decompress Hibernate jar file.
3. Move `GoldilocksDialect.class` file and `GoldilocksDialect$1.class` file to the decompressed `org/hibernate/dialect` directory.
4. Compress it again with Hibernate jar file.
5. Add the newly created jar file to classpath.

```
$ javac -cp hibernate-core-5.2.11.Final.jar GoldilocksDialect.java
$ jar -xvf hibernate-core-5.2.11.Final.jar
$ pwd
hibernate-release-5.2.11.Final/lib/required/
$ mv GoldilocksDialect*.class org/hibernate/dialect/
$ jar -cvf hibernate.5.2.11.jar META-INF/MANIFEST.MF .
```

## Porting to Program Source

Interworking is available by directly using the source file without porting the class file to jar file. Create `org.hibernate.dialect` package in the user project, then insert `GoldilocksDialect.java` file into this package.

## 36.3 Examples

### Configuration

hibernate-configuration XML file and hibernate-mapping XML file are required to interwork Hibernate and DB.

### Hibernate Configuration File

Configuration XML file sets the connect information to access the dialect class and DB, and sets Hibernate-mapping files.

For more information, refer to **Configuration**.

The following is an example of hibernate.conf.xml file.

```
<?xml version="1.0" encoding="utf-8"?>
<!DOCTYPE hibernate-configuration PUBLIC
"-//Hibernate/Hibernate Configuration DTD 3.0//EN"
"http://www.hibernate.org/dtd/hibernate-configuration-3.0.dtd">

<hibernate-configuration>
  <session-factory>
    <property
name="hibernate.connection.driver_class">sunje.goldilocks.jdbc.GoldilocksDriver</property>
    <property
name="hibernate.connection.url">jdbc:goldilocks://192.168.0.21:22581/test</property>
    <property name="hibernate.connection.username">test</property>
    <property name="hibernate.connection.password">test</property>
    <property name="hibernate.dialect">org.hibernate.dialect.GoldilocksDialect</property>
    <property name="show_sql">>true</property>
    <property name="format_sql">>true</property>
    <property name="hbm2ddl.auto"> create </property>
    <mapping resource="SampleTable.mapping.xml" />
  </session-factory>
</hibernate-configuration>
```

Set the DB connecting information on <session-factory> tag, and specifies the dialect class name of DB to connect to hibernate.dialect property. Also, specify hibernate-mapping files by using <mapping-resource> tag.

## Hibernate Mapping File

Mapping XML is a configuration file including mapping information about DB table and Java object. For more information, refer to **Mapping**.

The following is an example of SampleTable.mapping.xml file which was used in the example above.

```
<?xml version="1.0" encoding="UTF-8"?>
<!DOCTYPE hibernate-mapping PUBLIC
"-//Hibernate/Hibernate Mapping DTD 3.0//EN"
"http://hibernate.sourceforge.net/hibernate-mapping-3.0.dtd">
<hibernate-mapping>
  <class name="SampleTable" table="SAMPLETABLE">
    <id column="ID" name="id" type="long">
      <generator class="increment" />
    </id>
    <property column="STUDENT_NAME" name="name" type="string" />
    <property column="BIGINT_VALUE" name="bigintValue" type="long" />
    <property column="INT_VALUE" name="intValue" type="int" />
    <property column="SMALL_VALUE" name="smallValue" type="short" />
    <property column="FLOAT_VALUE" name="floatValue" type="float" />
    <property column="DOUBLE_VALUE" name="doubleValue" type="double" />
    <property column="NUMERIC_VALUE" name="numericValue" type="big_integer" precision="10"
scale="5" />
    <property column="DATE_VALUE" name="dateValue" type="date" />
    <property column="TIME_VALUE" name="timeValue" type="time" />
    <property column="TIMESTAMP_VALUE" name="timestampValue" type="timestamp" />
    <property column="VARBINARY_VALUE" name="binaryValue" type="byte[]" />
  </class>
</hibernate-mapping>
```

The mapping information about Java class and DB table are described on <class> tag. Data type used in a table column and Java are specified on <property> tag.

## Examples of Application

Java class to be mapped to DB table should be described. The following is an example of SampleTable.jav a which is described above.

```
import java.math.BigInteger;
import java.sql.Date;
import java.sql.Time;
import java.sql.Timestamp;
public class SampleTable {
    private long id;
    private String name;
    private long bigintValue;
    private int intValue;
    private short smallValue;
    private float floatValue;
    private double doubleValue;
    private BigInteger numericValue;
    private Date dateValue;
    private Time timeValue;
    private Timestamp timestampValue;
    private byte[] binaryValue;
    private String longvarcharValue;
    private byte[] longvarbinaryValue;

    public SampleTable() {
        this.name = null;
    }

    public SampleTable( String name ) {
        this.name = name;
    }

    public long getId() {
        return id;
    }

    public void setId( long id ) {
        this.id = id;
    }

    public String getName() {
        return name;
    }

    public void setName( String name ) {
        this.name = name;
    }
}
```



```

    }
    ....

```

get/ set function of a variable corresponding to a column of SampleTable table should be described.

The data is processed in SamleTable table as follows.

1. It obtains org.hibernate.SessionFactory object through a configuraion file.
2. It obtains org.hibernate.Session object through SessionFactory object.
3. It processes the desired operation by calling a method of a session object.

The following is an example of inserting, updating, retrieving, deleting data in SampleTable table of DB. It obtains SessionFactory object through org.hibernate.Configuration class.

```

public class HibernateSample
{
    private static SessionFactory mFactory;
    public static void main( String[] args ) {
        try {
            mFactory = new Configuration().configure( "hibernate.conf.xml"
).buildSessionFactory();
        } catch( Throwable ex ) {
            System.err.println( "Failed to create sessionFactory object." + ex);
            throw new ExceptionInInitializerError(ex);
        }
        HibernateSample sHibernateSample = new HibernateSample();

```

- Insert 3 records

```

Long sRecord1 = sHibernateSample.addSample( "RECORD_1" );
Long sRecord2 = sHibernateSample.addSample( "RECORD_2" );
Long sRecord3 = sHibernateSample.addSample( "RECORD_3" );

```

- Update record 1

```

sHibernateSample.updateSample( sRecord1, ....

```

- Fetch table

```

sHibernateSample.fetchSample( 0, 3 );

```

- Delete record 2

```
sHibernateSample.deleteSample( sRecord2 );
sHibernateSample.closeFactory();
    }
public void closeFactory() {
    mFactory.close();
}
....
```

The following is an example of a method inserting a record to HibernateSample class. First, it obtains a session object through SessionFactory class, then obtains org.hibernate.Transaction object. It can be committed or rolled back after starting a transaction by using a transaction class and inserting a record.

```
public Long addSample( String name ) {
    Session session = mFactory.openSession();
    Transaction tx = null;
    Long id = null;

    try{
```

- Begin transaction

```
tx = (Transaction) session.beginTransaction();
SampleTable sample = new SampleTable( name );
```

- Insert

```
id = (Long) session.save(sample);
```

- Commit transaction

```
tx.commit();

        System.out.println("add success");
    } catch( HibernateException e) {
        if( tx != null ) {
            tx.rollback();
        }
        System.out.println("add fail");
        e.printStackTrace();
    } finally {
        session.close();
    }
```

```

    return id;
}

```

The following is an example of a method retrieving SampleTable table. It obtains org.hibernate.Query object through a session class. fetchSample method retrieves SampleTable from offset to count.

```

public void fetchSample( int offset, int count ) {
    Session session = mFactory.openSession();
    Query query = null;

    try{
        query = session.createQuery( "FROM SampleTable" );
        query.setFirstResult( offset );
        query.setMaxResults( count );
        query.setFetchSize( 20 );

        @SuppressWarnings( "unchecked" )
        List<SampleTable> samples = (List<SampleTable>) query.list();
        for( Iterator<SampleTable> iter = samples.iterator(); iter.hasNext(); ) {
            SampleTable sample = (SampleTable) iter.next();
            System.out.print( "id: " + sample.getId() );
            ... Ellipsis ...
        }
    } catch ( HibernateException e ) {
        e.printStackTrace();
    } finally {
        session.close();
    }
}

```

The following is an example of a method updating SampleTable table. After altering to a set method described in SampleTable class, then it is updated by calling an update method of a session class.

```

public void updateSample( long id, ... ) {
    Session session = mFactory.openSession();
    Transaction tx = null;
    try {
        tx = session.beginTransaction();
        SampleTable sample = (SampleTable)session.get(SampleTable.class, id);
        sample.setName( name );
        ...
        session.update( sample );
    }
}

```

```
        tx.commit();
        System.out.println( "update success" );
    } catch ( HibernateException e ) {
        if( tx != null ){
            tx.rollback();
        }
        System.out.println("update fail");
        e.printStackTrace();
    } finally {
        session.close();
    }
}
```

The following is an example of deleting a record. It can be deleted by using a delete method of a session class.

```
public void deleteSample( long id ) {
    Session session = mFactory.openSession();
    Transaction tx = null;

    try {
        tx = session.beginTransaction();
        SampleTable sample = (SampleTable) session.get( SampleTable.class, id );
        session.delete( sample );
        tx.commit();

        System.out.println( "delete success" );
    } catch ( HibernateException e ) {
        if( tx != null ) {
            tx.rollback();
        }
        System.out.println("delete fail");
        e.printStackTrace();
    } finally {
        session.close();
    }
}
```

## **Part VI.**

---

# **Utility Manual**

<b>37. gcreatedb</b>	<b>3,897</b>
37.1 Overview of gcreatedb	3,898
Definition	3,898
Feature	3,898
Usage	3,898
Option	3,898
Example	3,899
37.2 Command Option	3,900
--cluster	3,900
--db_name	3,900
--db_comment	3,900
--timezone	3,900
--character_set	3,900
--char_length_units	3,901
--home	3,901
--member	3,901
--host	3,902
--port	3,902
--silent	3,902
--help	3,902
<b>38. glsnr</b>	<b>3,905</b>
38.1 Overview of glsnr	3,906
38.2 Command Options	3,907
--silent	3,907
--start	3,907
--stop	3,907
--status	3,908
--home	3,908
--help	3,909
38.3 Listener Configuration	3,910
Configuration File and Environment Variables	3,910
LISTEN_PORT	3,910
TCP_HOST	3,911
BACKLOG	3,911
DEFAULT_CS_MODE	3,911
TCP_VALIDNODE_CHECKING	3,912
TCP_INVITED_FILE	3,912
TCP_EXCLUDED_FILE	3,913
TIMEOUT	3,913

LISTENER_LOG_DIR .....	3,914
UDS_DIR .....	3,914
<b>39. gsql/gsqlnet (Interactive SQL Tool) .....</b>	<b>3,915</b>
39.1 Overview of gsql .....	3,916
Definition .....	3,916
Examples .....	3,916
39.2 Executing gsql .....	3,920
Information of gsql .....	3,920
Server Connection .....	3,921
Controlling Interactive Mode .....	3,922
Storing gsql configuration .....	3,923
39.3 Using Interactive Command .....	3,926
gsql Interactive Mode Command .....	3,926
Startup and Shutdown Server .....	3,928
Executing SQL Statements .....	3,932
Controlling Output Result .....	3,942
Logging Output Result .....	3,948
Querying SQL Object Information .....	3,949
Output DDL Statement of SQL Object .....	3,950
Controlling History .....	3,953
Editing SQL .....	3,954
Controlling Connection .....	3,955
Using Host Variable .....	3,956
Controlling Method of Treating SQL Statement .....	3,957
Information of SQL Execution Plan .....	3,962
39.4 Command Option Reference .....	3,964
Username Password .....	3,964
--as {SYSDBA ADMIN} .....	3,964
--conn-string .....	3,965
--dsn .....	3,965
--enable-color .....	3,966
--help .....	3,967
--import .....	3,968
--no-prompt .....	3,969
--prompt .....	3,969
--silent .....	3,970
--version .....	3,971
39.5 Interactive Command References .....	3,972
\\ .....	3,972

<code>\connect</code>	3,973
<code>\cstartup</code>	3,974
<code>\cshutdown</code>	3,975
<code>\ddl_cluster</code>	3,976
<code>\ddl_db</code>	3,977
<code>\ddl_tablespace</code>	3,981
<code>\ddl_profile</code>	3,982
<code>\ddl_audit_policy</code>	3,983
<code>\ddl_auth</code>	3,985
<code>\ddl_schema</code>	3,987
<code>\ddl_public_synonym</code>	3,991
<code>\ddl_table</code>	3,991
<code>\ddl_constraint</code>	3,993
<code>\ddl_index</code>	3,995
<code>\ddl_view</code>	3,996
<code>\ddl_sequence</code>	3,997
<code>\ddl_synonym</code>	3,998
<code>\ddl_procedure</code>	3,999
<code>\ddl_package</code>	4,000
<code>\desc</code>	4,001
<code>\dynamic sql :var</code>	4,003
<code>\edit</code>	4,005
<code>\exec</code>	4,008
<code>\exec :var := value</code>	4,010
<code>\exec sql</code>	4,014
<code>\explain plan</code>	4,015
<code>\help</code>	4,016
<code>\host</code>	4,018
<code>\history</code>	4,018
<code>\import</code>	4,019
<code>\idesc</code>	4,021
<code>\{n}</code>	4,022
<code>\prepare sql</code>	4,023
<code>\print</code>	4,024
<code>\quit</code>	4,026
<code>\set autocommit</code>	4,026
<code>\set autotrace</code>	4,028
<code>\set color</code>	4,029
<code>\set colsize</code>	4,030



\set ddlsize .....	4,032
\set error .....	4,033
\set heading .....	4,034
\set history .....	4,035
\set linesize .....	4,037
\set numsize .....	4,038
\set pagesize .....	4,039
\set serveroutput .....	4,040
\set time .....	4,042
\set timing .....	4,042
\set vertical .....	4,043
\shutdown .....	4,045
\spool .....	4,046
\startup .....	4,048
\var .....	4,049
<b>40. gloder/gloadernet(Upload/download Tool) .....</b>	<b>4,053</b>
40.1 Overview of gloder and gloadernet .....	4,054
Environment .....	4,054
Example .....	4,056
40.2 Using gloder .....	4,058
Datafile Type .....	4,058
Downloading Data .....	4,058
Uploading Data .....	4,066
Troubleshooting for Uploading .....	4,075
40.3 Control File Syntax .....	4,081
CHARACTERSET .....	4,081
TABLE .....	4,082
FIELDS TERMINATED BY .....	4,083
OPTIONALLY ENCLOSED BY .....	4,083
LINES TERMINATED BY .....	4,084
LTRIM .....	4,085
RTRIM .....	4,086
WHERE .....	4,087
40.4 gloder Argument References .....	4,088
Usage .....	4,088
Mandatory Argument .....	4,089
Optional Argument .....	4,090
<b>41. gdump .....</b>	<b>4,103</b>
41.1 Overview of gdump .....	4,104

Definition	4,104
Argument	4,104
41.2 Examples of Using gdump	4,107
Control File	4,107
Datafile	4,109
Log File	4,111
Incremental Backup File	4,113
Property File	4,116
Commit Log	4,117
Log Buffer File	4,118
Pending Log Buffer File	4,118
<b>42. tablediff</b>	<b>4,121</b>
42.1 Overview of tablediff	4,122
Background	4,122
Features	4,122
Characteristics	4,123
File Configuration	4,123
42.2 Usage	4,124
Command Usage	4,124
Property Option	4,125
<b>43. gsyncher</b>	<b>4,131</b>
43.1 Overview of gsyncher	4,132
Definition	4,132
Features	4,132
Usage	4,132
Options	4,132
43.2 Examples	4,133
<b>44. gmon</b>	<b>4,137</b>
44.1 Overview of gmon	4,138
Definition	4,138
Features	4,138
Usage	4,138
Options	4,138
44.2 Examples	4,140
<b>45. gtrclogger</b>	<b>4,141</b>
45.1 Overview of gtrclogger	4,142
Definition	4,142
Features	4,142

Usage .....	4,142
Options .....	4,143
45.2 Examples .....	4,144
<b>46. glocator .....</b>	<b>4,145</b>
46.1 Overview of glocator .....	4,146
Definition .....	4,146
Usage .....	4,146
Options .....	4,146
46.2 Using glocator .....	4,150
Data File .....	4,150
CSTARTUP and CSHUTDOWN .....	4,150
Replication .....	4,151
46.3 Features of glocator .....	4,153
Connection Service .....	4,153
Cluster Failover .....	4,154
46.4 glocator Configuration .....	4,155
Configuration File and Environment Variable .....	4,155
Configuration Properties .....	4,155
<b>47. gagent .....</b>	<b>4,163</b>
47.1 Overview of gagent .....	4,164
Definition .....	4,164
Usage .....	4,164
Options .....	4,164
47.2 gagent Configuration .....	4,168
Configuration File and Environment Variable .....	4,168
Configuration Properties .....	4,168
<b>48. gloctl .....</b>	<b>4,173</b>
48.1 Overview of gloctl .....	4,174
Definition .....	4,174
Usage .....	4,174
Options .....	4,174
48.2 Interactive Command References .....	4,178
ADD MEMBER .....	4,178
ADD SERVICE .....	4,179
DROP MEMBER .....	4,180
DROP SERVICE .....	4,180
EXPORT .....	4,181
HELP .....	4,181

IMPORT .....	4,182
QUIT .....	4,183
SET TIMEOUT .....	4,183
48.3 Location File .....	4,184
Description .....	4,184
48.4 Configuration .....	4,186
PORT .....	4,186
LOCATOR_HOST .....	4,186
LOCATOR_PORT .....	4,186
MESSAGE_TIMEOUT .....	4,187

**37.**

---

**gcreatedb**

## 37.1 Overview of gcreatedb

### Definition

gcreatedb is a database creation utility provided by GOLDDILOCKS.

### Feature

A new database is created by using DB\_Name, comment, time zone, character set specified by a user.

### Usage

```
gcreatedb [options]
```

### Option

```
--cluster          cluster system (if not specified, stand-alone system)
--db_name          database name
--db_comment       database comment
--timezone         timezone ( {+/-}{TZH:TZM} )
--character_set    character set
                   SQL_ASCII
                   UTF8
                   UHC
                   GB18030
--char_length_units char length units
                   OCTETS
                   CHARACTERS
--home             home directory
--member          local member name
--host            host address
--port           host port
--silent         suppresses the display of the result message
```

`--help` print help message

## Example

```
$ gcreatedb --db_name="goldilocks" --db-comment="goldilocks database" --timezone="+09:00"  
--character_set="UTF8" --silent
```

## 37.2 Command Option

### --cluster

It creates the database of a cluster environment.

If this option is not used, then it creates the database of a stand alone environment.

### --db\_name

It specifies the database name which a user wants to create.

The default value is "goldilocks".

The maximum length of database name is 128.

### --db\_comment

It specifies the database comment which a user wants to create.

The default value is "goldilocks database".

The maximum length of database comment is 1024.

### --timezone

It is the time zone value of database.

The default value is the **TIMEZONE** value of the property.

The property is applied when database is created and it has a value in range of '-14:00' ~ '+14:00'.

### --character\_set

It is the database character set.

The default value is the **CHARACTER\_SET** value of the property.

The property is applied when database is created, and its value is set to one of the followings.

- GB18030



- SQL\_ASCII
- UHC
- UTF8

## --char\_length\_units

It is the char length unit value which is used when defining the string column type such as CHAR, VARCHAR and omitting its char length unit as follows.

```
CREATE TABLE t1
(
  id CHAR( 10 OCTETS ),           ❶ It refers to 10 bytes.
  name VARCHAR( 128 CHARACTERS ), ❷ It refers to 128 characters.
  addr VARCHAR( 1024 )           ❸ char length unit is omitted.
```

The default value is the **CHAR\_LENGTH\_UNITS** value of the property.

The property is applied when database is created, and its value is set to one of the followings.

- OCTETS: It is the number of bytes.
- CHARACTERS: It is the number of characters.

The default value of char length unit is defined as CHARACTERS in the SQL standard and it is defined as follows in other DBMS.



- OCTETS is used in Oracle, DB2.
- CHARACTERS is used in MS-SQL, MySQL, PostgreSQL.

## --home

It sets the home directory of the database.

The default value uses \$GOLDILOCKS\_HOME environment variable.

## --member

It sets the name of a local database in a cluster environment.

## --host

It sets the host address of a local database in a cluster environment.

## --port

It sets the port number of a local database in a cluster environment.

## --silent

Result messages are not displayed.

## --help

Help messages are displayed.

```
$ gcreatedb --help
Usage
  gcreatedb [options]
Options:
  --db_name           database name
  --db_comment        database comment
  --timezone          timezone ( {+/-}{TZH:TZM} )
  --character_set     character set
                     SQL_ASCII
                     UTF8
                     UHC
                     GB18030
  --char_length_units char length units
                     OCTETS
                     CHARACTERS
  --silent            suppresses the display of the result message
  --help              print help message
examples:
  gcreatedb --db_name="goldilocks" --db_comment="goldilocks database" --timezone="+09:00"
```

```
| --character_set="UTF8" --char_length_units="OCTETS" --silent
```



**38.**

---

**glsnr**

## 38.1 Overview of glsnr

glsnr is a listener which GOLDILOCKS enables remote access through the network in the client/ server environment. glsnr should be run on the server for the network access to GOLDILOCKS.

glsnr is used as follows.

```
| $ glsnr [options]
```

## 38.2 Command Options

The followings are cell prompt options for using glsnr.

### **--silent**

#### **Description**

It does not display the message for execution.

#### **Example**

```
$ glsnr --start --silent
```

### **--start**

#### **Description**

It starts running glsnr. If glsnr is already running, an error occurs.

#### **Example**

```
$ glsnr --start  
Listener is started successfully.
```

### **--stop**

#### **Description**

It stops the currently running glsnr.

## Example

```
$ glsnr --stop  
Listener is stopped.
```

## --status

## Description

It displays the message about glsnr status.

## Example

```
$ glsnr --status  
Listener is not running.  
$ glsnr --start  
Listener is started successfully.  
$ glsnr --status  
Listener process ID : 27880  
Listener configuration file : /home/goldilocks/goldilocks_home/conf/goldilocks.listener.conf  
Unix Domain Path : /tmp/unix-glsnr.22581  
TCP Listen Host : 0.0.0.0, Port : 22581  
default C/S mode : Dedicated  
Connection Timeout(second) : 100  
Listener is running.
```

## --home

## Description

It sets db home.

## Example

```
$ glsnr --start --home Gliese/home/g1n1_home  
Listener is started successfully.  
$ glsnr --status
```



```
Listener process ID : 20777
Listener configuration file :
/home/goldilocks/Gliese/home/g1n1_home/conf/goldilocks.listener.conf
Unix Domain Path : /tmp/unix-glsnr.22581
TCP Listen Host : 0.0.0.0, Port : 22581
default C/S mode : Dedicated
Connection Timeout(second) : 100
Listener is running.
```

## --help

### Description

It displays the help message.

### Example

```
$ glsnr --help

Usage:
  glsnr [options]

Options:

  --silent      don't print message
  --start       start listener
  --stop        stop listener
  --status      show listener status
  --help        show listner help messages
```

## 38.3 Listener Configuration

### Configuration File and Environment Variables

glsnr uses the configuration file or environment variables for setting the configuration.

The environment variable is specified by using the name which 'GOLDILOCKS\_' is added to the property name of the configuration as a prefix. For example, setting the LISTEN\_PORT in configuration file is as same as specifying \$GOLDILOCKS\_LISTEN\_PORT.

The contents of configuration file precedes the environment variable settings. (In other words, environment variables are applied only if the configuration file is not set.)

The environment file of glsnr is \$GOLDILOCKS\_DATA/conf/goldilocks.listener.conf. If the corresponding file is changed or the environment variables are set and glsnr is started to run, then the glsnr driving environment is modified.

If a user want to modify and apply the glsnr environment during running glsnr, a user should stop glsnr and change the content of configuration file or set the environment variable and then restart glsnr.

If a user stops the glsnr, a problem does not occur for the client which is already connected, but the problem occurs when being connected from a new client.

### LISTEN\_PORT

It is the port on which the glsnr waits for the connection.

Item	Description
Name	LISTEN_PORT
Description	It is the port on which the glsnr waits for a connection.
Data type	INT
Default value/ range	22581 / 1024 ~ 49151

### Description

The client who wants a TCP connection should try to connect to the specified port.

The port is available from 1024 to 49151.

## TCP\_HOST

It is an IP address of NIC of which glsnr waits for the connection.

Item	Description
Name	TCP_HOST
Description	It is the IP address which the glsnr binds.
Data type	ip address
Default value	0.0.0.0

### Description

The client who wants a TCP connection should access the IP address specified above. The IP address is used in IPv4 or IPv6 format.

## BACKLOG

It is the number of clients which the glsnr can handle when multiple clients simultaneously access.

Item	Description
Name	BACKLOG
Description	It is the number of client of which glsnr waits for the connection.
Data type	INT
Default value/ range	1024 / 1 ~ 32768

### Description

This setting value does not guarantee the number of concurrent connector of the client.

## DEFAULT\_CS\_MODE

It sets the access mode when the access mode is not designated as dedicated or shared on the client.

Item	Description
Name	DEFAULT_CS_MODE
Description	It sets the default access mode.

Item	Description
Data type	String ( dedicated   shared )
Default value	dedicated

## Description

- The client/ server mode connected via glsnr supports two modes, which are dedicated and shared.
- Generally, the access mode is set as dedicated or shared on the client (It is .odbcini for ODBC), then it accesses. However, if it is not set on the client, the access mode is determined by setting DEFAULT\_CS\_MODE.

## TCP\_VALIDNODE\_CHECKING

It sets whether to check the validity of the client attempting to access.

Item	Description
Name	TCP_VALIDNODE_CHECKING
Description	It sets whether to check the client validity.
Data type	String ( NO   INVITED   EXCLUDED )
Default value	NO

## Description

- If the value is set to *NO*, the client validity is not checked.
- If the value is set to *INVITED* and the file set in TCP\_INVITED\_FILE exists, then only the client having the IP address of the file set in TCP\_INVITED\_FILE is set to be valid.
- If the value is set to *EXCLUDED* and the file set in TCP\_EXCLUDED\_FILE exists, then only the client excluding the client who has IP address of the file set in TCP\_EXCLUDED\_FILE is set to be valid.

## TCP\_INVITED\_FILE

It is used only when the value of TCP\_VALIDNODE\_CHECKING is *INVITED*.

Item	Description
Name	TCP_INVITED_FILE
Description	It is the file with the valid user (IP address) list.
Data type	String

Item	Description
Default value	'goldilocks.invited.conf'

## Description

If the set file exists, only the user (IP address) within the file is allowed to access.

## TCP\_EXCLUDED\_FILE

It is used only when the value of TCP\_VALIDNODE\_CHECKING is *EXCLUDED*.

Item	Description
Name	TCP_EXCLUDED_FILE
Description	It is the file with the invalid user (IP address) list.
Data type	String
Default value	'goldilocks.excluded.conf'

## Description

If the set file exists, anyone except for the user (IP address) within the file is allowed to access.

## TIMEOUT

It is the glsnr timeout value and its unit is second.

Item	Description
Name	TIMEOUT
Description	glsnr timeout
Data type	INT
Default value/ range	100 / ( 0 ~ 2147483647 )

## Description

If the response is too slow or there is not a response from the client when glsnr communicates with the client, the connection is released by the specified timeout.

## LISTENER\_LOG\_DIR

It sets the directory which stores the log to be display from the glsnr.

Item	Description
Name	LISTENER_LOG_DIR
Description	It sets the directory which stores the log of the glsnr.
Data type	String
Default value	'<GOLDILOCKS_DATA>/trc'

### Description

<GOLDILOCKS\_DATA> of the setting value is replaced with the value of the environment variable \$GOLDILOCKS\_DATA.

## UDS\_DIR

It sets the directory in which the Unix Domain Socket file used in glsnr is stored.

Item	Description
Name	UDS_DIR
Description	It sets the directory in which the Unix Domain Socket file used in glsnr is stored.
Data type	String
Default value/ range	'/tmp' / Maximum 60 byte

### Description

The maximum length of the directory should be set within 60 bytes. The absolute path of the Unix Domain Socket file (directory name + file name) depends on OS, but usually it is around 100 bytes.

**39.**

---

**gsq/gsqlnet (Interactive SQL Tool)**

## 39.1 Overview of gsql

The followings are execution files.

**Table 39-1** Execution files

Execution file name	Description
gsql	It is used in Direct Attach (D/A) environment.
gsqlnet	It is used in Client/ Server (C/S) environment.



All commands supported by gsql are equally supported by gsqlnet.

### Definition

gsql is an interactive utility for processing SQL statements provided by GOLDILOCKS.

Using gsql, a user can query the results of the SELECT statement as well as execute SQL statements without any application.

gsql program executes the SQL statement, and queries a brief information of the objects such as tables and indexes through the gsql specific commands beginning with \, and it provides various features such as startup or shutdown of the server, controlling the output, and querying the execution plan of SQL statement.

### Examples

This chapter describes the method of creating/dropping the table, manipulating data, performing a query by using gsql.

gsql is operated in an interactive mode as follows. When connecting normally, it waits for entering the SQL statement or gsql command with *gSQL>* prompt.

```
% gsql test test
Connected to GOLDILOCKS Database.
gSQL>
```

Create a table by executing **CREATE TABLE** statement and commit the transaction as follows.



```
gSQL> CREATE TABLE t1 ( id INTEGER, name VARCHAR(128) );
Table created.
gSQL> COMMIT;
Commit complete.
```

Insert the data into the created table by executing **INSERT INTO** statement, then commit the transaction as follows. The second INSERT statement is an example of inserting two rows.

```
gSQL> INSERT INTO t1 VALUES ( 1, 'leekmo' );
1 row created.
```

- Two rows are inserted.

```
gSQL> INSERT INTO t1 VALUES ( 2, 'mkkim' ), ( 3, 'xcom73' );
2 rows created.
gSQL> COMMIT;
Commit complete.
```

The column `addr` is added to the table and data is updated by executing **UPDATE** statement as follows.

```
gSQL> ALTER TABLE t1 ADD COLUMN ( addr VARCHAR(1024) );
Table altered.
gSQL> UPDATE t1 SET addr = 'Seoul, Korea' WHERE id = 1;
1 row updated.
gSQL> UPDATE t1 SET addr = 'Inchon, Korea' WHERE id = 3;
1 row updated.
gSQL> COMMIT;
Commit complete.
```

The inserted data is queried by using **SELECT** query as follows. The query result consists of the header representing column names and the information of each row in a single line. NULL is expressed in lowercase null.

```
gSQL> SELECT * FROM t1 ORDER BY 1;
ID NAME      ADDR
-----
1 leekmo Seoul, Korea
2 mkkim null
3 xcom73 Inchon, Korea
3 rows selected.
```

A host variable is declared, and the value is put in the host variable then a query using the host variable is

performed as follows.

```
gSQL> \var v_id INTEGER
gSQL> \exec :v_id := 1
gSQL> SELECT * FROM t1 WHERE id = :v_id;
ID NAME  ADDR
-- -----
1 leekmo Seoul, Korea
1 row selected.
```

The SQL statement is prepared by using `\prepare sql` and the SELECT statement above is repeatedly performed by using `\exec`, changing the value of host variable. ODBC and JDBC simulate prepare/ execute operation in gsql interactive mode as follows.

```
gSQL> \var v_id INTEGER
gSQL> \prepare sql SELECT * FROM t1 WHERE id = :v_id;
SQL prepared.
gSQL> \exec :v_id := 2
gSQL> \exec
ID NAME  ADDR
-- -----
2 mkkim null
1 row selected.
gSQL> \exec :v_id := 3
gSQL> \exec
ID NAME  ADDR
-- -----
3 xcom73 Incheon, Korea
1 row selected.
```

A scrollable cursor is declared in an embedded SQL, ODBC, JDBC, and the data retrieval using the cursor is simulated via gsql as follows. The cursor `cur1` declared by using `DECLARE cursor_name` is the scrollable KEYSET cursor and various fetch orientations may be used by using `FETCH cursor_name`.

```
gSQL> \var v_id INTEGER
gSQL> \var v_name VARCHAR(128)
gSQL> DECLARE cur1 KEYSET CURSOR FOR SELECT id, name FROM t1 ORDER BY id;
Cursor declared.
gSQL> OPEN cur1;
Cursor is open.
gSQL> FETCH cur1 INTO :v_id, :v_name;
V_ID V_NAME
```

```

-----
      1 leekmo
1 row fetched.
gSQL> FETCH cur1 INTO :v_id, :v_name;
V_ID V_NAME
-----
      2 mkkim
1 row fetched.
gSQL> FETCH cur1 INTO :v_id, :v_name;
V_ID V_NAME
-----
      3 xcom73
1 row fetched.
gSQL> FETCH cur1 INTO :v_id, :v_name;
no rows fetched.
gSQL> FETCH ABSOLUTE 2 cur1 INTO :v_id, :v_name;
V_ID V_NAME
-----
      2 mkkim
1 row fetched.
gSQL> FETCH PRIOR cur1 INTO :v_id, :v_name;
V_ID V_NAME
-----
      1 leekmo
1 row fetched.
gSQL> CLOSE cur1;
Cursor closed.

```

The created table t1 is dropped and the gsql interactive mode is terminated as follows.

```

gSQL> DROP TABLE t1;
Table dropped.
gSQL> COMMIT;
Commit complete.
gSQL> \q
%
```

## 39.2 Executing gsql

### Information of gsql

Refer to the following options.

**Table 39-2** Options

Option	Description
<code>--help</code>	Option list
<code>--version</code>	gsql version information

A user can view the gsql command options which are executable at the shell prompt via `--help` option as follows.

```
% gsql --help
Usage
  gsql [user_name [password]] [options]
Arguments:
  user_name      user name
  password       password
Options:
  --version                print version information and exit
  --import FILE           import sql FILE
... Ellipsis ...
%
```

gsql program has a version separate from GOLDILOCKS server version, and the version is viewed by using `--version` option as follows. It is recommended to use the gsql program in the same version as the GOLDILOCKS server.

```
% gsql --version
%
```

The version of GOLDILOCKS server can be view via **VERSION** function as follows.

```
gSQL> SELECT version() FROM dual;
VERSION()
-----
1 row selected.
```

## Server Connection

Refer to the following options.

**Table 39-3** Options

Option	Description
Username Password	It is the user and password of connection.
--as {SYSDBA ADMIN}	It specifies the connection role.
--conn-string	It specifies the connection string.
--dsn	It specifies Data Source Name (DSN).

## User Connection

Using gsql program, it can be connected to GOLDILOCKS server in various ways.

The simplest way to connect is using a username and password as follows. The following is an example that the test user connects to it by using the test password. When successfully connected, it operates in an interactive mode and the *gSQL>* prompt waits for the user command.

```
% gsql test test
Connected to GOLDILOCKS Database.
gSQL>
```

The following is an example that an error occurs when using an invalid username or password. When the login is failed, an error message is displayed and then the gsql program is terminated.

```
% gsql test invalid_password
ERR-28000(16004): invalid username/password; logon denied
%
```

The following is an example that an error occurs when the GOLDILOCKS server does not run. The gsql program is terminated with the error message as follows.

```
% gsql test test
ERR-HY000(11031): Unable to attach the shared memory segment
%
```

In addition, it can be connected via the following options. For more details, refer to the respective link.

- **--conn-string**
- **--dsn**

## SYSDBA Connection

The `--as {SYSDBA|ADMIN}` option is used to drive the server or to connect to SYSDBA role which has full access privilege on the database.

The following is an example of connecting with `--as sysdba` in the state of when the GOLDILOCKS server is not driven. `gSQL>` prompt is waiting in the state which is ready to drive GOLDILOCKS with the message *Connected to an idle instance.*

```
% gsql sys gliese --as sysdba
Connected to an idle instance.
gSQL>
```

The following is an example of connecting with `--as sysdba` when the GOLDILOCKS server is already driven.

```
% gsql sys gliese --as sysdba
Connected to GOLDILOCKS Database.
gSQL>
```

For more information, refer to [Startup and Shutdown Server](#).

## Quit gsql

gsql is quit by using `\quit` or `\q` command as follows.

For more information, refer to [\quit](#).

```
gSQL> \quit
%
```

## Controlling Interactive Mode

Refer to the following options.

**Table 39-4** Options

Option	Description
<code>--prompt</code>	It specifies the prompt.
<code>--no-prompt</code>	It removes the prompt.
<code>--import</code>	It executes the SQL file with input.
<code>--silent</code>	When executing the SQL file, the command and the result are not displayed.

Option	Description
<code>--enable-color</code>	The query result is displayed by grouping per row.

## Controlling Prompt

When starting an interactive mode, the prompt may be changed by using `--prompt` option as follows. The following is an example that the prompt is changed to `GOLDILOCKS>` prompt, not to `gSQL>` prompt.

```
% gsql test test --prompt GOLDILOCKS
Connected to GOLDILOCKS Database.
GOLDILOCKS>
```

For more information about controlling the prompt, refer to the following options.

- `--prompt`
- `--no-prompt`

## Executing from File

When processing batch operation by using `gsql` program, the SQL statement included in the file may be executed by using `--import` option. The following is an example of executing `PerformanceViewSchema.sql` file in the `$GOLDILOCKS_HOME/admin` directory. The example uses `--silent` option not to output the execution results.

```
% cd $GOLDILOCKS_HOME/admin
% gsql --as SYSDBA --import 'PerformanceViewSchema.sql' --silent
%
```

For more information about executing `gsql` from the file, refer to the following options.

- `--import`
- `--silent`
- `--enable-color`

## Storing gsql configuration

### gsql Configuration File (gsql.ini)

The `gsql` configuration file (`.gsql.ini`) consists of options which is automatically applied when `gsql` starts up, and it should be in the directory `$HOME`.

A user can set multiple dsn in the configuration file, and can specify different options for each dsn. If a user does not enter dsn when gsql starts up, the options in GOLDILOCKS are applied.

## Example

```
[GOLDILOCKS]
AUTOCOMMIT = OFF
AUTOTRACE = OFF
LINESIZE = 80
PAGESIZE = 20
VERTICAL = OFF
TIME = OFF
TIMING = OFF
ERROR = ON
COLSIZE = 8192
NUMSIZE = 20
DDLsize = 10000
HISTORY = 128
```

**Table 39-5** Options

Option	Minimum value	Maximum value	Default value
AUTOCOMMIT	OFF	ON	OFF
AUTOTRACE	OFF	ON/TRACEONLY	OFF
LINESIZE	1	10000	80
PAGESIZE	1	10000	20
VERTICAL	OFF	ON	OFF
TIME	OFF	ON	OFF
TIMING	OFF	ON	OFF
ERROR	ON	OFF	ON
COLSIZE	1	10485760	8192
NUMSIZE	1	50	20
DDLsize	1	10485760	10000
HISTORY	0	100000	128



If `.gsql.ini` does not exist or the option value is invalid, it is ignored.



## **glogin.sql**

glogin.sql is a global configuration file and it is positioned in `$GOLDILOCKS_DATA/conf/glogin.sql`. If glogin.sql file exists when driving gsql, then it reads the file and executed the statement included in the file. In this way, all gsql sessions are set (e.g.line size).

## **login.sql**

login.sql is a user configuration file. If login.sql file exists in the current directory when driving gsql, then it reads the file and executed the statement included in the file.

The login.sql configuration takes precedence over the glogin.sql configuration.

## 39.3 Using Interactive Command

### gsql Interactive Mode Command

Refer to the following commands.

**Table 39-6** Commands

gsql command	Description
<code>\help</code>	gsql command list

gsql program operates in an interactive mode through **Server Connection** as follows.

```
% gsql test test
Connected to GOLDILOCKS Database.
gSQL>
```

A user may enter the SQL statement on the prompt line then execute it or enter the unique command which is executable in an gsql interactive mode then execute it. The gsql command begins with back-slash (\) to distinguish it from the SQL statement. The gsql command which begins with back-slash (\) can not be used in the application, while SQL statement can be directly used in the application.

 The gsql interactive mode command begins with \.

The following is an example of executing SQL statement in an interactive mode.

```
gSQL> SELECT * FROM dual;
DUMMY
-----
X
1 row selected.
```

The following is an example of executing the same SELECT statement by using `\exec sql`, gsql command. `\exec sql` command is a unique gsql command although the syntax of `\exec sql` is as same as the syntax of EXEC SQL referring to the beginning of SQL statement in an **Embedded SQL**.

```
gSQL> \exec sql SELECT * FROM dual;
DUMMY
-----
```

```
X
1 row selected.
```

The current time can be output on the prompt by setting via `\set time`.

```
gSQL> \set time on
12:45:34 gSQL> SELECT * FROM dual;
DUMMY
-----
X
1 row selected.
12:45:37 gSQL>
```

The unique commands of gsql interactive mode can be queried with the command `\help` as follows.

```
gSQL> \help
\help
\q[uit]
\i[mport] {'FILE'}          Import SQL
\ed[it] [{'FILE'}|[HISTORY] num}] Edit SQL statement
\\                          Executes the most recent history entry
\{n}                        Executes n'th history entry
\hi[story]                  Show history entries
\desc  {[schema.]table_name} Show table description
\idesc  {[schema.]index_name} Show index description
\spo[ol] ['filename' | OFF] Stores query results in a file
\ho[st] [command]          Executes an operating system command
\set vertical  {ON|OFF}
\set time     {ON|OFF}
\set timing   {ON|OFF}
\set color    {ON|OFF}
\set error    {ON|OFF}
\set autocommit {ON|OFF}
\set autotrace {ON|TRACEONLY|OFF}
\set serveroutput {ON|OFF}
\set heading  {ON|OFF}
\set linesize {n}        0 < n <= 100000
\set pagesize {n}        0 < n <= 100000
\set colsize  {n}        0 < n <= 104857600
\set numsize  {n}        0 < n <= 50
\set ddlsize  {n}        0 < n <= 100000
\set history  {n}        n <= 100000 ( if n < 0, clear history buffer )
```

```

\var          {host_var_name} {INTEGER|BIGINT|VARCHAR(n)}
\exec        [[:host_var_name] := {constant}]
\exec sql    {sql string}
\prepare sql  {sql string}
\dynamic sql  {host_var_name}
\explain plan [{ON|ONLY}] {sql string}
\print       [{host_var_name}]
\ddl_cluster
\ddl_db
\ddl_tablespace {name}
\ddl_profile    {name}
\ddl_auth       {name}
\ddl_schema     {name}
\ddl_table      {[schema.]name}
\ddl_constraint {[schema.]name}
\ddl_index      {[schema.]name}
\ddl_view       {[schema.]name}
\ddl_sequence   {[schema.]name}
\ddl_synonym     {[schema.]name}
\ddl_public_synonym {name}
\ddl_procedure  {[schema.]name}
\ddl_package    {[schema.]name}
\startup        {[nomount|mount|open]}
\shutdown       {[abort|immediate|transactional|normal]}
\cstartup       {[nomount|mount|open]}
\cshutdown      {[abort|normal]}
\connect        userid password [as {sysdba|admin}]

```

## Startup and Shutdown Server

Refer to the following commands.

**Table 39-7** Commands

gsql Command	Description
<b>\startup</b>	It starts up the server.
<b>\shutdown</b>	It shuts down the server.
<b>\cstartup</b>	It starts up the server for the cluster environment.
<b>\cshutdown</b>	It shuts down the server for the cluster environment.

## Standalone

It should be connected by using SYSDBA role or ADMIN role as follows to startup or shutdown the server.

- SYSDBA role
  - It has all privileges related to DBA such as the server startup or shutdown.
- ADMIN role
  - It has the same privileges as SYSDBA but it is allowed to connect only one session.
  - It is the role for when a valid session does not exist or for emergency connection under abnormal circumstances.

The following is an example of connecting by using SYSDBA role when the GOLDILOCKS server is not driven.

```
% gsql sys gliese --as sysdba
Connected to an idle instance.
gSQL>
```

gsql is connected to an idle instance in the state of when GOLDILOCKS server does not exist. gsql drives the GOLDILOCKS server on the specific step through **\startup** and connects to the server. The following is an example of driving the GOLDILOCKS server on NOMOUNT phase.

```
gSQL> \startup NOMOUNT
Startup success
gSQL>
```

**\startup** command is used only when initially driving GOLDILOCKS. Each step of the GOLDILOCKS server is switched by using **ALTER SYSTEM {MOUNT | OPEN} DATABASE** after driving the GOLDILOCKS server and connecting to the server.

```
gSQL> ALTER SYSTEM MOUNT DATABASE;
System altered.
gSQL> ALTER SYSTEM OPEN DATABASE;
System altered.
gSQL>
```

**\startup** command is executed without any extra option as follows when GOLDILOCKS server is driven on OPEN phase whose service is available without switching the step.

```
% gsql sys gliese --as sysdba
Connected to an idle instance.
gSQL> \startup
Startup success
```

```
gSQL>
```

If the server is already driven on a certain step, `\startup` command outputs an error message as follows. Unless the server is driven up to OPEN phase, it may be driven on OPEN phase by using ALTER SYSTEM as follows.

```
% gsql sys gliese--as sysdba
Connected to GOLDILOCKS Database.
gSQL> \startup
ERR-HY000(11029): shared memory segment exists
gSQL> ALTER SYSTEM MOUNT DATABASE;
System altered.
gSQL> ALTER SYSTEM OPEN DATABASE;
System altered.
gSQL>
```

For more information about the server startup, refer to the followings.

- Step of the server startup: **Multi-level Startup**
- Command for the initial server startup: **\startup**
- Altering the server step: **ALTER SYSTEM {MOUNT | OPEN} DATABASE**

`\shutdown` command is used as follows to shutdown the server. For more information about the server shutdown, refer to **\shutdown**.

```
gSQL> \shutdown
Shutdown success
gSQL>
```

## Cluster

LOCATOR\_DSN property should be defined in `odbc.ini` file to startup or shutdown the server by using `\cstartup` command and `\cshutdown` command, and it should be connected with SYSDBA role or ADMIN role by using `gsqlnet`.

The following is an example of connecting with SYSDBA role by using `gsqlnet` when GOLDILOCKS server is not driven.

```
% gsqlnet sys gliese --as sysdba
Connected to an idle instance.
gSQL>
```

The following is an example of driving GOLDILOCKS server on LOCAL OPEN phase by using `\cstartup` co

mmmand. Then it switches the server to OPEN phase.

```
gSQL> \cstartup LOCAL OPEN
Startup success
gSQL> ALTER SYSTEM OPEN GLOBAL DATABASE;
System altered.
gSQL>
```

\cstartup command and \cshutdown command are used in C/S environment, so glsnr should be on service on all servers to startup or shutdown the server.

The following is an example of trying to drive GOLDILOCKS server when glsnr is not on service.

```
gSQL> \cstartup
ERR-HY000(58000): MEMBER(G1N1): the sender failed to connect to the member(1)
ERR-HY000(11067): MEMBER(G1N1): fail to connect to an host with a socket : connect() :
stnConnect() returned errno(111)
gSQL>
```

The following is an example of defining LOCATOR\_DSN property and LOCATOR DSN property in **odbc.ini** file.

```
% cat .odbc.ini
# Edit the SYSTEM or USER DSN ini file (/etc/odbc.ini or ~/.odbc.ini) and add a data source
using the syntax:
[GOLDILOCKS]
HOST=127.0.0.1
PORT=20101
UID=test
PWD=test
LOCATOR_DSN=LOCATOR
[LOCATOR]
FILE=/home/test/.locator.ini
```

The following is an example of trying to drive the server when LOCATOR\_DSN property is not defined in odbc.ini file.

```
gSQL> \cstartup
ERR-HY000(40057): not specified valid location information
gSQL>
```

Commands excluding \CSTARTUP {LOCAL | GLOBAL} OPEN are applied only to the corresponding GOLDILOCKS server. Therefore, other servers should be started up to LOCAL OPEN phase for multi-level startup

by using **ALTER SYSTEM {MOUNT | OPEN} DATABASE** after `\CSTARTUP NOMOUNT`, `MOUN` commands.

The following is an example of trying multi-level startup after `\CSTARTUP MOUNT`. The corresponding server is started on MOUNT phase, but the other server is not started up to LOCAL OPEN phase, so an error occurs.

```
gSQL> \CSTARTUP MOUNT
Startup success
gSQL> ALTER SYSTEM OPEN LOCAL DATABASE;
System altered.
gSQL> ALTER SYSTEM OPEN GLOBAL DATABASE;
ERR-HY000(58000): MEMBER(G1N1): the sender failed to connect to the member(1)
ERR-HY000(11067): MEMBER(G1N1): fail to connect to an host with a socket : connect() :
stnConnect() returned errno(111)
gSQL>
```

For more information about the server startup, refer to the followings.

- Step of the server startup: **Multi-level Startup**
- Command for the initial server startup: `\cstartup`
- Altering the server step: **ALTER SYSTEM {MOUNT | OPEN} DATABASE**

`\cshutdown` command is used as follows to shutdown the entire server. For more information about the entire server shutdown, refer to `\cshutdown`.

```
gSQL> \cshutdown
Shutdown success
gSQL>
```

## Executing SQL Statements

Refer to the following commands.

**Table 39-8** Commands

gsql command	Description
<code>\import</code>	It executes SQL file.
<code>\set autocommit</code>	It automatically COMMITs whenever executing the SQL statement.
SQL References	It is a type of SQL statement.



## Entering SQL Statement

In an interactive mode, gsql outputs the interactive mode prompt gSQL> and waits for a user input. After entering the SQL statement, gsql performs the SQL statement by transferring it to the server. In an interactive mode, the SQL statement is completed by entering semi-colon (;), then entering **enter**. After executing the SQL statement, gsql outputs the result and the prompt gSQL>, and then waits for user input.

The following is an example of entering the SQL statement on a single line and executing it.

```
gSQL> SELECT * FROM dual;
DUMMY
-----
X
1 row selected.
gSQL>
```

The following is an example of entering SQL statement across multiple lines and executing it. If **enter** is used in the state of which the SQL statement is not completed, gsql outputs the line number, moves to the next line and waits for user input.

```
gSQL> SELECT id, name
2
```

When a user continuously completes entering all SQL statements, then enters semicolon (;) and **enter** as follows, the SQL statement is executed and gSQL> prompt waits for the next command.

```
gSQL> SELECT id, name
2 FROM t1
3 WHERE id > 0;
ID NAME
-- -----
1 leekmo
2 mkkim
3 xcom73
3 rows selected.
gSQL>
```

The SQL statement is not recognized to be completed of input because the semi-colon (;) within the single quote (') is recognized as a string.

```
gSQL> SELECT id, ';'
2 FROM t1
3 WHERE id = 1;
```

```
ID ';'
-- ---
 1 ;
1 row selected.
gSQL>
```

## Entering SQL Statement from File

In an interactive mode, `\import` is used to execute the SQL statement from the file, not to execute it by directly entering the SQL statement. The following is an example of executing multiple SQL statements by reading the file `sample.sql`. For more information, refer to `\import`.

```
gSQL> \import 'sample.sql'
```

- Drop table

```
DROP TABLE IF EXISTS t1;
Table dropped.
```

- Create table

```
CREATE TABLE t1
(
  id   INTEGER PRIMARY KEY,
  name VARCHAR(128),
  addr VARCHAR(128)
);
Table created.
```

- Create index

```
CREATE INDEX t1_idx_name ON t1(name);
Index created.
```

- Insert three rows

```
INSERT INTO t1
VALUES ( 1, 'leekmo', 'Seoul, Korea' ),
       ( 2, 'mkkim' , 'Seoul, Korea' ),
       ( 3, 'xcom73', 'Inchon, Korea' );
3 rows created.
```

- Commit transaction

```
COMMIT;
Commit complete.
gSQL>
```

## gsql Comment

The comments in an interactive mode are as same as those in the SQL statement. The comments input from the file via the `--import` option is also as same as those in the SQL statement. For more information about comments on SQL statement, refer to **Comments**.

The following is an example of using the line comment in an interactive mode.

```
gSQL> -- outside line-comment
gSQL> SELECT id, name
2 FROM t1 -- inside line-comment
3 WHERE id = 1;
ID NAME
-- -----
1 leekmo
1 row selected.
gSQL>
```

The following is an example of executing the file content with the `\import` command. It is treated in the same way as the comment in an interactive mode. And `gSQL>` prompt waits for the next SQL statement after all contents of the file are executed.

```
gSQL> \import 'sample.sql'
```

- Drop table

```
DROP TABLE IF EXISTS t1;
Table dropped.
```

- Create table

```
CREATE TABLE t1
(
  id    INTEGER PRIMARY KEY,
  name  VARCHAR(128),
  addr  VARCHAR(128)
```

```
);
```

Table created.

- Create index

```
CREATE INDEX t1_idx_name ON t1(name);
```

Index created.

- Insert three rows

```
INSERT INTO t1
VALUES ( 1, 'leekmo', 'Seoul, Korea' ),
       ( 2, 'mkkim' , 'Seoul, Korea' ),
       ( 3, 'xcom73', 'Inchon, Korea' );
```

3 rows created.

- Commit transaction

```
COMMIT;
```

Commit complete.

```
gSQL>
```

The following is an example of using the multi-line comment in an interactive mode.

```
gSQL> SELECT id, name
```

```
2      /*
```

```
3      multi-line
```

```
4      comment
```

```
5      */
```

```
6      FROM t1
```

```
7      WHERE id = 1;
```

```
ID NAME
```

```
-- -----
```

```
1 leekmo
```

1 row selected.

```
gSQL>
```

The comments which is available in gsql interactive mode are as same as those in the SQL statement. For more information about the comments, refer to **Comments** of SQL statement.

## SQL Execution Result

When a user performs a query such as SELECT statement in an interactive mode, gsql outputs the query results. The query result consists of the header with the column names, the data of the query result, and summary the query results at the end.

The following is an example of executing the SELECT statement.

```
gSQL> SELECT * FROM t1;
ID NAME  ADDR
-- -----
 1 leekmo Seoul, Korea
 2 mkkim Seoul, Korea
 3 xcom73 Incheon, Korea
3 rows selected.
gSQL>
```

In the example above, the header of output results consists of the column name and the hyphen (-) which distinguishes it from data. The query result is displayed in the middle of the output result, each row of query result is displayed on a single line, and each column value is separated with the space. The summary of the query result is displayed at the end. In this case, it refers that three rows are retrieved.

**Data Definition Language, Data Manipulation Language, Control Language** statements (except for SQL query) displays the summarized information of the execution result corresponding to the SQL statements characteristics.

The followings are the examples of respectively executing the DDL, DML, Control Language, displaying the results.

- DDL statement

```
gSQL> CREATE TABLE t1 ( id INTEGER, name VARCHAR(128) );
Table created.
```

- DML statement

```
gSQL> INSERT INTO t1 VALUES ( 1, 'leekmo' );
1 row created.
```

- Transaction control statement

```
gSQL> COMMIT;
Commit complete.
gSQL>
```

## SQL Execution Error

The error which occurs during executing the SQL statement consists of the following information when it.

- SQLSTATE information: SQLSTATE value of SQL standard
- Error code: Unique error code value of GOLDILOCKS
- Error message: An error message describing the cause of error

The following is an example of an error when executing the SELECT statement. The error message consists of that value of ERR-42000 corresponds to SQLSTATE and the unique error code of GOLDILOCKS is the value of (16040) and a table or view corresponding to invalid\_table does not exist at line 2.

```
gSQL> SELECT id, name
2     FROM invalid_table
3     WHERE id > 0;
ERR-42000(16040): table or view does not exist :
        FROM invalid_table
            *
ERROR at line 2:
gSQL>
```

## Interactive Command Execution Result

The interactive commands used together with SQL statements displays the same results and errors as those executing SQL statements.

The following is an example of preparing the SQL statement by using `\prepare sql` and executing it by using `\exec`.

```
gSQL> \prepare sql SELECT * FROM t1;
SQL prepared.
gSQL> \exec
ID NAME  ADDR
-- -----
1 leekmo Seoul, Korea
2 mkkim  Seoul, Korea
3 xcom73 Incheon, Korea
3 rows selected.
gSQL>
```

The following is an example of an error occurred in the SQL statement when using `\prepare sql`. It displays an error which is as same as that occurs when executing the SQL statement.

- An error of \prepare sql command

```
gSQL> \prepare sql SELECT * FROM invalid_table;
ERR-42000(16040): table or view does not exist :
SELECT * FROM invalid_table
          *
ERROR at line 1:
```

- An error of the same SQL statement

```
gSQL> SELECT * FROM invalid_table;
ERR-42000(16040): table or view does not exist :
SELECT * FROM invalid_table
          *
ERROR at line 1:
gSQL>
```

If the gsql commands in an interactive mode do not include the SQL statement or when the command does not have any result to display, only *gSQL>* prompt is displayed without any extra message when the command is successfully performed.

The following is an example of successfully performing the interactive command without a message. The error message is displayed when an error occurs.

- When the interactive gsql command is normally performed

```
gSQL> \var v1 INTEGER
gSQL> \exec :v1 := 1
```

- When the interactive gsql command causes an error

```
gSQL> \var v2 INVALID TYPE
ERR-42000(40000): syntax error
\var v2 INVALID TYPE
.....^      ^
Error at line 1
gSQL>
```

For more information about the performance result of the interactive command, refer to the description and example of the interactive command in **Interactive Command References**.

## Autocommitting SQL statement

The SQL statements in the gsql interactive mode may commit or roll back the transaction by using the **COMMIT** or **ROLLBACK** statement.

The following is an example of performing COMMIT or ROLLBACK after performing multiple INSERT statements. Whereas the first INSERT statement is successfully committed by COMMIT, the second and third INSERT statements are rolled back by ROLLBACK in the following example.

```
gSQL> INSERT INTO t1 VALUES ( 1, 'leekmo' );
1 row created.
gSQL> COMMIT;
Commit complete.
gSQL> INSERT INTO t1 VALUES ( 2, 'mkkim' );
1 row created.
gSQL> INSERT INTO t1 VALUES ( 3, 'xcom73' );
1 row created.
gSQL> ROLLBACK;
Rollback complete.
gSQL> SELECT * FROM t1;
ID NAME
-- -----
1 leekmo
1 row selected.
gSQL>
```

If a user wants to automatically COMMIT every transaction whenever performing the SQL statements, it can be controlled by using the **\set autocommit** as follows. When performing the same SQL statement as the example above, each SQL statement is automatically committed, so the transaction of the second and the third INSERT statements are completed regardless of ROLLBACK.

```
gSQL> \set autocommit on
gSQL> INSERT INTO t1 VALUES ( 1, 'leekmo' );
1 row created.
gSQL> COMMIT;
Commit complete.
gSQL> INSERT INTO t1 VALUES ( 2, 'mkkim' );
1 row created.
gSQL> INSERT INTO t1 VALUES ( 3, 'xcom73' );
1 row created.
gSQL> ROLLBACK;
Rollback complete.
```



```

gSQL> SELECT * FROM t1;
ID NAME
-- -----
 1 leekmo
 2 mkkim
 3 xcom73
3 rows selected.
gSQL>

```

For more information about controlling automatic COMMIT, refer to `\set autocommit`.

## Forced Termination of SQL Statement Being Executed

SQL statements being executed in an interactive mode is forcibly terminated by entering `Ctrl+C`.

The following is an example of which the SELECT statement being executed for a long time is forcibly terminated. If `Ctrl+C` is entered by using a keyboard during performing the SQL statement, the error message, operation canceled, is displayed and the SQL statement is forcibly terminated.

```

gSQL> SELECT COUNT(*)
FROM
  t1 AS v01,
  t1 AS v02,
  t1 AS v03,
  t1 AS v04,
  t1 AS v05,
  t1 AS v06,
  t1 AS v07,
  t1 AS v08,
  t1 AS v09,
  t1 AS v10,
  t1 AS v11,
  t1 AS v12,
  t1 AS v13,
  t1 AS v14,
  t1 AS v15,
  t1 AS v16,
  t1 AS v17,
  t1 AS v18,
  t1 AS v19,
  t1 AS v20;
2 3 4 5 6 7 8 9 10 11 12 13 14 15 16 17 18 19 20 21 22

```

^C

ERR-HY008(13043): operation canceled

gSQL&gt;

## Controlling Output Result

Refer to the following commands.

Table 39-9 Commands

gsql command	Description
<code>\set color</code>	It identifies each row with different color.
<code>\set colsize</code>	It controls the maximum size of the column results.
<code>\set error</code>	It controls whether an error message is displayed.
<code>\set linesize</code>	It controls the maximum output length of the row.
<code>\set numsize</code>	It controls the maximum number of digit of the numeric value.
<code>\set pagesize</code>	It controls the number of row to be included in a page.
<code>\set timing</code>	It outputs the execution time of the SQL statement.
<code>\set vertical</code>	It displays each column in a single line.

## Controlling Page Configuration

As described in **SQL Execution Result**, the query results display the column names in the header, displays the data, then the summary information at the end.

If there are many query results, they are divided into the unit of `pagesize` (default value is 20), and each page outputs the column names and data set. When the output of all pages is completed, the summary information is displayed at the end.

The following is an example of the output of query results by changing the `pagesize` to 5. For more information about controlling the `pagesize`, refer to `\set pagesize`.

```
gSQL> \set pagesize 5
```

```
gSQL> SELECT table_schema, table_name FROM dictionary WHERE table_name like 'ALL_%' FETCH 20;
```

```
TABLE_SCHEMA      TABLE_NAME
-----
DICTIONARY_SCHEMA ALL_ALL_TABLES
DICTIONARY_SCHEMA ALL_COL_COMMENTS
DICTIONARY_SCHEMA ALL_COL_PRIVS
DICTIONARY_SCHEMA ALL_COL_PRIVS_MADE
DICTIONARY_SCHEMA ALL_COL_PRIVS_REC'D
```

```

TABLE_SCHEMA      TABLE_NAME
-----
DICTIONARY_SCHEMA ALL_CONSTRAINTS
DICTIONARY_SCHEMA ALL_CONS_COLUMNS
DICTIONARY_SCHEMA ALL_DB_PRIVS
DICTIONARY_SCHEMA ALL_DB_PRIVS_MADE
DICTIONARY_SCHEMA ALL_DB_PRIVS_RECD
TABLE_SCHEMA      TABLE_NAME
-----
DICTIONARY_SCHEMA ALL_INDEXES
DICTIONARY_SCHEMA ALL_IND_COLUMNS
DICTIONARY_SCHEMA ALL_SCHEMAS
DICTIONARY_SCHEMA ALL_SCHEMA_PATH
DICTIONARY_SCHEMA ALL_SCHEMA_PRIVS
TABLE_SCHEMA      TABLE_NAME
-----
DICTIONARY_SCHEMA ALL_SCHEMA_PRIVS_MADE
DICTIONARY_SCHEMA ALL_SCHEMA_PRIVS_RECD
DICTIONARY_SCHEMA ALL_SEQUENCES
DICTIONARY_SCHEMA ALL_SEQ_PRIVS
DICTIONARY_SCHEMA ALL_SEQ_PRIVS_MADE
20 rows selected.
gSQL>

```

Each row of the query result is output in linesize unit (default value is 80). If the row length of the result is bigger than linesize, it is output on the next line.

The following is an example of the query result before and after the linesize is adjusted to 200. For more information about controlling linesize, refer to `\set linesize`.

```

gSQL> SELECT * FROM dict_columns WHERE table_name = 'USER_TABLES' FETCH 3;
TABLE_SCHEMA      TABLE_NAME      COLUMN_NAME
-----
COMMENTS
-----
DICTIONARY_SCHEMA USER_TABLES      TABLE_SCHEMA
Schema of the table
DICTIONARY_SCHEMA USER_TABLES      TABLE_NAME
Name of the table
DICTIONARY_SCHEMA USER_TABLES      TABLESPACE_NAME
Name of the tablespace containing the table
3 rows selected.

```

- Set the linesize to 200.

```
gSQL> \set linesize 200
gSQL> SELECT * FROM dict_columns WHERE table_name = 'USER_TABLES' FETCH 3;
TABLE_SCHEMA      TABLE_NAME  COLUMN_NAME    COMMENTS
-----
DICTIONARY_SCHEMA USER_TABLES  TABLE_SCHEMA  Schema of the table
DICTIONARY_SCHEMA USER_TABLES  TABLE_NAME    Name of the table
DICTIONARY_SCHEMA USER_TABLES  TABLESPACE_NAME Name of the tablespace containing the table
3 rows selected.
gSQL>
```

To increase the readability of each row on the terminal by differentiating rows, each row can be output by varying the color through `\set color` as described below. For more information, refer to `\set color`.

```
gSQL> \set color on
gSQL> SELECT table_schema, table_name FROM dictionary WHERE table_name like 'ALL_%' FETCH 10;
TABLE_SCHEMA      TABLE_NAME
-----
DICTIONARY_SCHEMA ALL_ALL_TABLES
DICTIONARY_SCHEMA ALL_COL_COMMENTS
DICTIONARY_SCHEMA ALL_COL_PRIVS
DICTIONARY_SCHEMA ALL_COL_PRIVS_MADE
DICTIONARY_SCHEMA ALL_COL_PRIVS_REC'D
DICTIONARY_SCHEMA ALL_CONSTRAINTS
DICTIONARY_SCHEMA ALL_CONS_COLUMNS
DICTIONARY_SCHEMA ALL_DB_PRIVS
DICTIONARY_SCHEMA ALL_DB_PRIVS_MADE
DICTIONARY_SCHEMA ALL_DB_PRIVS_REC'D
10 rows selected.
gSQL>
```

To output the query result rows in the column unit on a single line, not in the line unit, `\set vertical on` is used. The following is an example of displaying the query results in a column unit. For more information, refer to `\set vertical`.

```
gSQL> SELECT * FROM v$system_stat FETCH 5;
STAT_NAME          STAT_VALUE  COMMENTS
-----
SYSTEM_SAR          3 system available resource( 0:none, 1:session 2:database )
MAX_ENVIRONMENT_COUNT 128 maximum environment count
FREE_ENVIRONMENT_ID  3 available environment identifier
```

```

MAX_SESSION_COUNT          128 maximum session count
FREE_SESSION_ID            4 available session identifier
5 rows selected.
gSQL> \set vertical on
gSQL> SELECT * FROM v$system_stat FETCH 5;
      STAT_NAME # SYSTEM_SAR
      STAT_VALUE # 3
      COMMENTS # system available resource( 0:none, 1:session 2:database )
      STAT_NAME # MAX_ENVIRONMENT_COUNT
      STAT_VALUE # 128
      COMMENTS # maximum environment count
      STAT_NAME # FREE_ENVIRONMENT_ID
      STAT_VALUE # 3
      COMMENTS # available environment identifier
      STAT_NAME # MAX_SESSION_COUNT
      STAT_VALUE # 128
      COMMENTS # maximum session count
      STAT_NAME # FREE_SESSION_ID
      STAT_VALUE # 4
      COMMENTS # available session identifier
5 rows selected.
gSQL>

```

## Controlling Data Output

gsq converts all data included in the query result to a string, then outputs it.

For a numeric data type, numsize (default value is 20) is output in the digit unit, and a numeric value bigger than numsize is output in an exponent form. The following is an example of controlling the output by using the numsize. For more information, refer to `\set numsize`.

```

gSQL> SELECT num, ( num * num ) AS result FROM t1;
      NUM          RESULT
-----
1234567890123 1.52415787532276E+24
1 row selected.
gSQL> \set numsize 50
gSQL> SELECT num, ( num * num ) AS result FROM t1;
      NUM          RESULT
-----
1234567890123 1524157875322755800955129
1 row selected.

```

```
gSQL>
```

The output of the numeric value may be controlled in various ways by using the `TO_CHAR( number )` function as the following example.

```
gSQL> SELECT num, TO_CHAR( num * num, '$999,999,999,999,999,999,999,999,999' ) AS result FROM
t1;

          NUM RESULT
-----
1234567890123    $1,524,157,875,322,755,800,955,129
1 row selected.
gSQL>
```

For the date/ time data types such as DATE/ TIME/ TIMESTAMP, gsql determines the output type by using the property information as follows.

- `NLS_DATE_FORMAT`
- `NLS_TIMESTAMP_FORMAT`
- `NLS_TIMESTAMP_WITH_TIME_ZONE_FORMAT`
- `NLS_TIME_FORMAT`
- `NLS_TIME_WITH_TIME_ZONE_FORMAT`

The property is used when the format information is not entered in the functions such as `TO_CHAR()`, `TO_DATE()`. When connected for the first time, gsql acquires the property information and uses it to output the date/ time data value, whereas the property above is used only when the application using ODBC or JDBC uses the functions such as `TO_CHAR()`, `TO_DATE()` in SQL statement. When the property is changed to the following SQL statement in an interactive mode, gsql uses the updated property information.

- `ALTER SESSION SET property_name`
- `ALTER SYSTEM SET property_name`

The following is an example of controlling the output for the DATE column.

```
gSQL> SELECT enter_date FROM t1;
ENTER_DATE
-----
2014-08-26
1 row selected.
gSQL> ALTER SESSION SET NLS_DATE_FORMAT = 'DD-MON-YYYY';
Session altered.
gSQL> SELECT enter_date FROM t1;
ENTER_DATE
-----
```

```
26-AUG-2014
1 row selected.
gSQL>
```

The output of the date/ time value can be controlled by using `TO_CHAR( datetime )` function without altering property as follows.

```
gSQL> SELECT TO_CHAR( enter_date, 'DD-MON-YYYY' ) as result FROM t1;
RESULT
-----
26-AUG-2016
1 row selected.
gSQL>
```

A binary string such as `BINARY` or `VARBINARY` is output as hex values as follows.

```
gSQL> select * from t1;
BINARY_VALUE
-----
A010002F370000000000
1 row selected.
gSQL>
```

The data of the `LONG VARCHAR`, `LONG VARBINARY` type may include a very long string, so it outputs the data as much as `colsize` (default value is 8192). The following is an example of outputting the part of the `TEXT` column data of `LONG VARCHAR` data type by reducing the `colsize`. The whole data may be output by increasing the `colsize`. For more information, refer to `\set colsize`.

```
gSQL> \set colsize 100
gSQL> SELECT view_name, text FROM all_views WHERE view_name = 'ALL_ALL_TABLES';
VIEW_NAME      TEXT
-----
ALL_ALL_TABLES SELECT
                auth.AUTHORIZATION_NAME          1 OWNER
                , sch.SCHEMA_NAME
```

1 row selected.

```
gSQL>
```

## Execution Time of SQL Statement

The execution time of the SQL statement is output by using `\set timing` on as follows. For more information, refer to `\set timing`.

```
gSQL> \set timing on
gSQL> SELECT * FROM dual;
DUMMY
-----
X
1 row selected.
Elapsed time: 0.08500 ms
```

## Logging Output Result

All results performed in gsql are simultaneously logged to the file when they are output on the terminal.

**Table 39-10** Commands

gsql command	Description
<code>\spool</code>	It logs the output result to a file.

For more information about the features related to logging output results, refer to the commands of `\spool`.

The output result is logged as the following example.

- Start to log the execution result on result.txt

```
gSQL> \SP00L 'result.txt'
```

- Check the spool status

```
gSQL> \SP00L
currently spooling to result.txt
gSQL> SELECT * FROM T1 WHERE C1 < 10;
```

- Stop the spool feature

```
gSQL> \SP00L OFF
```



## Querying SQL Object Information

The information about SQL objects may be queried with the views of **DICTIONARY\_SCHEMA**, **INFORMATION\_SCHEMA**.

**Table 39-11** Commands

gsql command	Description
<code>\desc</code>	It queries the table information.
<code>\idesc</code>	It queries the index information.

For example, there are the table and index created as follows.

```
CREATE TABLE t1
(
  id   INTEGER PRIMARY KEY,
  name VARCHAR(128),
  addr VARCHAR(128)
);
CREATE INDEX t1_idx_name ON t1(name);
```

A user may query the information related to the table by performing a series of SQL statements as follows.

```
gsQL> SELECT table_schema, table_name FROM user_tables WHERE table_name = 'T1';
TABLE_SCHEMA TABLE_NAME
-----
PUBLIC      T1
1 row selected.
gsQL> SELECT column_name, data_type, nullable FROM user_tab_columns WHERE table_schema =
'PUBLIC' AND table_name = 'T1';
COLUMN_NAME DATA_TYPE      NULLABLE
-----
ID           NUMBER          N
NAME        CHARACTER VARYING Y
ADDR        CHARACTER VARYING Y
3 rows selected.
gsQL> SELECT index_name FROM user_indexes WHERE table_schema = 'PUBLIC' AND table_name = 'T1';
INDEX_NAME
-----
T1_PRIMARY_KEY_INDEX
T1_IDX_NAME
```

2 rows selected.

gSQL>

gsql may easily query the information related to the table by using `\desc` as follows. For more information about the output, refer to `\desc`.

```
gSQL> \desc t1
COLUMN_NAME TYPE IS_NULLABLE
-----
ID NUMBER(10,0) FALSE
NAME VARCHAR(128) TRUE
ADDR VARCHAR(128) TRUE
INDEX_NAME TABLESPACE_NAME INDEX_TYPE IS_UNIQUE COLUMNS
-----
T1_PRIMARY_KEY_INDEX MEM_TEMP_TBS BTREE TRUE ID
T1_IDX_NAME MEM_TEMP_TBS BTREE FALSE NAME
CONSTRAINT_NAME CONSTRAINT_TYPE ASSOCIATED_INDEX COLUMNS
-----
T1_PRIMARY_KEY PRIMARY KEY T1_PRIMARY_KEY_INDEX ID
gSQL>
```

`\idesc` describes the information related to the index as the following example. For more information, refer to `\idesc`.

```
gSQL> \idesc t1_idx_name
COLUMN_NAME ORDINAL_POSITION IS_ASCENDING_ORDER IS_NULLS_FIRST
-----
NAME 1 TRUE FALSE
gSQL>
```

## Output DDL Statement of SQL Object

The following gsql commands output the DDL statement corresponding to the current state of the SQL object. As well as the CREATE statement which creates the SQL object, DDL statement of the related object may be output through the various options.



The objects stored in the recycle bin are not output.

Table 39-12 Commands

gsq command	Description
<code>\ddl_cluster</code>	It outputs the cluster-related DDL.
<code>\ddl_db</code>	It outputs the database-related DDL.
<code>\ddl_tablespace</code>	It outputs the tablespace-related DDL.
<code>\ddl_profile</code>	It outputs the profile-related DDL.
<code>\ddl_audit_policy</code>	It outputs the audit policy-related DDL.
<code>\ddl_auth</code>	It outputs the account-related DDL.
<code>\ddl_schema</code>	It outputs the schema-related DDL.
<code>\ddl_public_synonym</code>	It outputs the public synonym-related DDL.
<code>\ddl_table</code>	It outputs the table-related DDL.
<code>\ddl_constraint</code>	It outputs the constraint-related DDL.
<code>\ddl_index</code>	It outputs the index-related DDL.
<code>\ddl_view</code>	It outputs the view-related DDL.
<code>\ddl_sequence</code>	It outputs the sequence-related DDL.
<code>\ddl_synonym</code>	It outputs the synonym-related DDL.
<code>\ddl_procedure</code>	It outputs the procedure-related DDL.
<code>\ddl_package</code>	It outputs the package-related DDL.
<code>\set ddlsize</code>	It controls the size of the DDL output buffer.

For example, the orders table is created as follows.

```
gSQL>
CREATE TABLE ORDERS
(
  O_ID          INTEGER,
  O_D_ID       INTEGER,
  O_W_ID       INTEGER,
  O_C_ID       INTEGER,
  O_ENTRY_D    TIMESTAMP,
  O_CARRIER_ID INTEGER,
  O_OL_CNT     NUMERIC(8),
  O_ALL_LOCAL  NUMERIC(1),
  PRIMARY KEY(O_W_ID, O_D_ID, O_ID) INDEX ORDERS_PK_IDX
);
```

Table created.

The CREATE TABLE statement which created the orders table in the example above is output by using `\ddl_table` as follows.

```

gSQL> \ddl_table orders CREATE
SET SESSION AUTHORIZATION "TEST";
CREATE TABLE "PUBLIC"."ORDERS"
(
    "O_ID" NUMBER( 10, 0 )
    , "O_D_ID" NUMBER( 10, 0 )
    , "O_W_ID" NUMBER( 10, 0 )
    , "O_C_ID" NUMBER( 10, 0 )
    , "O_ENTRY_D" TIMESTAMP( 6 ) WITHOUT TIME ZONE
    , "O_CARRIER_ID" NUMBER( 10, 0 )
    , "O_OL_CNT" NUMBER( 8, 0 )
    , "O_ALL_LOCAL" NUMBER( 1, 0 )
)
PCTFREE 10
PCTUSED 60
INITRANS 4
MAXTRANS 8
STORAGE
(
    INITIAL 524288
    NEXT 262144
    MINSIZE 524288
    MAXSIZE 562949953159168
)
TABLESPACE "MEM_DATA_TBS"
;

```

From the example above, SET AUTHORIZATION statement refers to the owner who performed CREATE TABLE statement. The CREATE TABLE statement is output together with the information that the user does not input such as the schema name to which the table belongs, the tablespace name in which the table is stored and the physical information of the table.

DDL corresponding to the constraints generated in the table is output by using the CONSTRAINT option of \ddl\_table as follows.

```

gSQL> \ddl_table orders CONSTRAINT
SET SESSION AUTHORIZATION "TEST";
ALTER TABLE "PUBLIC"."ORDERS"
ADD CONSTRAINT "PUBLIC"."ORDERS_PRIMARY_KEY"
PRIMARY KEY
(
    "O_W_ID" ASC NULLS LAST

```

```

, "O_D_ID" ASC NULLS LAST
, "O_ID" ASC NULLS LAST
)
INDEX "ORDERS_PK_IDX"
PCTFREE 10
INITRANS 4
MAXTRANS 8
STORAGE
(
  INITIAL 524288
  NEXT 262144
  MINSIZE 524288
  MAXSIZE 562949953159168
)
TABLESPACE "MEM_TEMP_TBS"
NOT DEFERRABLE
INITIALLY IMMEDIATE
;

```

For more information, refer to the `gsq` command corresponding to the SQL object.



If a user uses the command such as `\ddl_table` and simultaneously performs DDL on the relevant SQL object, it may output different results, so DDL should not be simultaneously performed.

## Controlling History

`gsq` controls the history of executed SQL statements in an interactive mode.

**Table 39-13** Commands

gsq command	Description
<code>\</code>	It executes the previous SQL.
<code>\{n}</code>	It executes the SQL statement corresponding to the history number.
<code>\history</code>	It queries the SQL execution history.
<code>\set history</code>	It controls the number of history buffer.

The following is an example of executing SQL statement which has already been performed may be performed again.

- The most recent successfully executed SQL statement is executed again.

```

gSQL> \\  

DUMMY  

-----  

X  

1 row selected.  

gSQL> \history  

ID SQL  

-----  

1 DROP TABLE IF EXISTS t1  

2 CREATE TABLE t1  

  (  

    id  INTEGER PRIMARY KEY,  

    name VARCHAR(128),  

    addr VARCHAR(128)  

  )  

3 CREATE INDEX t1_idx_name ON t1(name)  

4 INSERT INTO t1  

    VALUES ( 1, 'leekmo', 'Seoul, Korea' ),  

           ( 2, 'mkkim' , 'Seoul, Korea' ),  

           ( 3, 'xcom73', 'Inchon, Korea' )  

5 COMMIT  

6 select * from t1

```

- The first SQL in the history is executed.

```

gSQL> \1  

Table dropped.

```

For more information about the history related features of gsql, refer to **Commands** .

## Editing SQL

It edits the SQL statement by using the text editor. The text editor to be used may be specified in the environment variable EDITOR. If the environment variable EDITOR does not exist, vi is used by default.

**Table 39-14** Command

gsql command	Description
\edit	It edits the SQL statement by using the text editor.

When using the editing features, gsql runs the editor and hands over control to it. The user can freely edit

the SQL statements with the editor. When the editor ends, the control is handed over to gsql, and its content will be added as the last history.

The SQL statement edited by the editor may be executed through the last history execution command `\\`.



Only a single SQL statement can be edited with the SQL editor. An error occurs when executing multiple SQL statements.

The followings may be edited by using `\edit`.

- The most recently performed SQL statement
- The SQL statement stored in a file
- The SQL statement stored in the gsql history

For more information about the edit-related features in gsql, refer to `\edit`.

The SQL statement may be edited as the following example.

- The most recently performed SQL statement is edited.

```
gSQL> SELECT * FROM T1;
C1
--
 1
11
2 rows selected.
gSQL> \EDIT
SELECT * FROM T1 WHERE C1 < 10;
```

- The edited SQL statement is executed.

```
gSQL> \\
C1
--
 1
1 row selected.
```

## Controlling Connection

Refer to the following commands.

Table 39-15 Commands

gsql command	Description
<code>\connect</code>	It connects with a new user.
<code>\quit</code>	It quits the connection.

It is connected with a new user by using `\connect` in an interactive mode as follows. The existing session is terminated and a new session is created by using `\connect`. For more information, refer to `\connect`.

```
gSQL> \connect test test
gSQL>
```

The user may be changed by using the `SET SESSION AUTHORIZATION user_identifier` statement as follows. `\connect` commits all transactions being executed and creates a new session whereas the `SET SESSION AUTHORIZATION` statement changes the user while keeping intact the existing sessions.

```
gSQL> SET SESSION AUTHORIZATION test;
Session set.
gSQL>
```

Interactive mode is terminated by using `\quit` as follows. For more information, refer to `\quit`.

```
gSQL> \quit
%
```

## Using Host Variable

`gsql` declares a host variable in an interactive mode, and assigns a value to the host variable, then uses the host variable together with the SQL statement.

Table 39-16 Commands

gsql command	Description
<code>\var</code>	It declares the host variable.
<code>\exec :var := value</code>	It assigns the value to the host variable.
<code>\print</code>	It outputs the value of the host variable.
<code>\dynamic sql :var</code>	It executes SQL statements stored in the host variable.

The following is an example of declaring the host variable by using `\var`, and assigning the value to the host variable by using `\exec :var := value`, and querying the value of the host variable by using `\print`. For more information, refer to each command.



```

gSQL> \var v_id INTEGER
gSQL> \exec :v_id := 1
gSQL> \print v_id
V_ID
----
   1
gSQL>

```

The variable declared in an interactive mode may be used as the input parameter in the SQL statement as follows.

```

gSQL> SELECT * FROM t1 WHERE id = :v_id;
ID NAME   ADDR
-- -----
  1 leekmo Seoul, Korea
1 row selected.
gSQL>

```

The variable declared in an interactive mode may be used as the output parameter in the SQL statement as follows.

```

gSQL> SELECT id INTO :v_id FROM t1 WHERE name = 'mkkim';
V_ID
----
   2
1 row selected.
gSQL>

```

## Controlling Method of Treating SQL Statement

The SQL process methods which are frequently used when processing the SQL such as the execution of prepare/ execute statement or the retrieval by using the cursor may be simulated by using the gsql interactive mode command before developing the application.

**Table 39-17** Commands

gsql command	Description
<code>\exec sql</code>	It directly executes the SQL statement.
<code>\prepare sql</code>	It prepares the SQL statement.
<code>\exec</code>	It executes the prepared SQL statement.
<code>\dynamic sql :var</code>	It executes the SQL statement stored in the host variable.

The following Java application is a part of code in \$GOLDILOCKS\_HOME/sample/JDBC/JdbcSample.java.

```
public static void main(String[] args) throws SQLException
{
    Connection con = createConnectionByDriverManager("TEST", "test");
    Statement stmt = con.createStatement();
    stmt.execute("CREATE TABLE SAMPLE_TABLE ( ID INTEGER, NAME CHAR(20) )");
    PreparedStatement pstmt = con.prepareStatement("INSERT INTO SAMPLE_TABLE VALUES (?,
?)" );
    pstmt.setInt(1, 100);
    pstmt.setString(2, "Tom");
    pstmt.executeUpdate();
    pstmt.setInt(1, 200);
    pstmt.setString(2, "Jerry");
    pstmt.executeUpdate();
    ResultSet rs = stmt.executeQuery("SELECT * FROM SAMPLE_TABLE");
    while (rs.next())
    {
        System.out.println("ID = " + rs.getInt(1) + ": " + rs.getString(2));
    }
    rs.close();
    stmt.close();
    pstmt.close();
    con.close();
    Connection con2 = createConnectionByDataSource("TEST", "test");
    Statement stmt2 = con2.createStatement();
    stmt2.execute("DROP TABLE SAMPLE_TABLE");
    stmt2.close();
    con2.close();
}
```

The implementation above which used the PreparedStatement class of Java code may be simulated by using `\prepare sql` and `\exec` as follows.

```
gSQL> \connect test test
gSQL> \var v_int INTEGER
gSQL> \var v_string VARCHAR(128)
gSQL> CREATE TABLE SAMPLE_TABLE ( ID INTEGER, NAME CHAR(20) );
Table created.
gSQL> \prepare sql INSERT INTO SAMPLE_TABLE VALUES (:v_int, :v_string);
SQL prepared.
```

```

gSQL> \exec :v_int := 100
gSQL> \exec :v_string := 'Tom'
gSQL> \exec
1 row created.
gSQL> \exec :v_int := 200
gSQL> \exec :v_string := 'Jerry'
gSQL> \exec
1 row created.
gSQL> SELECT * FROM SAMPLE_TABLE;
  ID NAME
-----
 100 Tom
 200 Jerry
2 rows selected.
gSQL> \connect test test
gSQL> DROP TABLE SAMPLE_TABLE;
Table dropped.
gSQL> \quit
%
```

The following embedded SQL program is a part of code in `$GOLDILOCKS_HOME/sample/EmbeddedSQL/sample2.gc`.

```

int main(int argc, char **argv)
{
    EXEC SQL BEGIN DECLARE SECTION;
    int          sEmpNo;
    varchar      sENAME[20 + 1];
    char         sJob[20];
    long         sSalary;
    EXEC SQL END DECLARE SECTION;
    ... Ellipsis ...
}
```

- Retrieve employee

```

EXEC SQL
    DECLARE EMP_CUR CURSOR FOR
    SELECT empno, ename, job, sal
    FROM   EMP;
EXEC SQL OPEN EMP_CUR;
if(sqlca.sqlcode != 0)
{
```

```

        PRINT_SQL_ERROR("[ERROR] SQL ERROR -");
        goto fail_exit;
    }
    printf(" EMPNO      ENAME                      JOB      SALARY\n");
    printf("===== \n");
    while( 1 )
    {
        EXEC SQL
            FETCH EMP_CUR
            INTO :sEmpNo, :sENAME, :sJob, :sSalary;
        if(sqlca.sqlcode == SQL_NO_DATA)
        {
            break;
        }
        else if(sqlca.sqlcode != 0)
        {
            PRINT_SQL_ERROR("[ERROR] SQL ERROR -");
            goto fail_exit;
        }
        sRecordCount ++;
        printf("%6d %20s %10s %8ld\n",
            sEmpNo, sENAME.arr, sJob, sSalary);
    }
    printf("===== \n");
    printf("Record Count = %d\n", sRecordCount);
    printf("===== \n");
    EXEC SQL CLOSE EMP_CUR;
    if(sqlca.sqlcode != 0)
    {
        PRINT_SQL_ERROR("[ERROR] SQL ERROR -");
        goto fail_exit;
    }

    ... Ellipsis ...
}

```

The query processing which uses the cursor in an embedded SQL program above may be simulated in gsql interactive mode as follows.

```

gSQL> \var sEmpNo INTEGER
gSQL> \var sENAME VARCHAR(20)

```

```

gSQL> \var sJob CHAR(20)
gSQL> \var sSalary BIGINT
gSQL> DECLARE EMP_CUR CURSOR FOR
        SELECT empno, ename, job, sal
        FROM EMP;
Cursor declared.
gSQL> OPEN EMP_CUR;
Cursor is open.
gSQL> FETCH EMP_CUR
        INTO :sEmpNo, :sENAME, :sJob, :sSalary;
SEMPNO SENAME SJOB          SSALARY
-----
2854 Park  RND              800
1 row fetched.
gSQL> FETCH EMP_CUR
        INTO :sEmpNo, :sENAME, :sJob, :sSalary;
SEMPNO SENAME SJOB          SSALARY
-----
2098 Kim   SALESMAN          1600
1 row fetched.
gSQL> FETCH EMP_CUR
        INTO :sEmpNo, :sENAME, :sJob, :sSalary;
SEMPNO SENAME SJOB          SSALARY
-----
2175 Choi  SALESMAN          1250
1 row fetched.
gSQL> CLOSE EMP_CUR;
Cursor closed.
gSQL>

```



The following statements are limitedly used in an embedded SQL in other DBMS. On the other hand, in GOLDILOCKS, the followings are used not only in an embedded SQL but also can be used as an argument of SQL processing functions when developing the application of ODBC or JDBC.

- **SELECT .. INTO**
- **DECLARE cursor\_name**
- **OPEN cursor\_name**
- **FETCH cursor\_name**
- **CLOSE cursor\_name**

## Information of SQL Execution Plan

Refer to the following commands.

**Table 39-18** Command

gsql Command	Description
<code>\explain plan</code>	It outputs the execution plan for the SQL statement.
<code>\set autotrace</code>	It sets whether to output the execution plan.

The execution plan of the SQL statement is viewed in an interactive mode by using `\explain plan` or `\set autotrace` as follows. For more information about the command, refer to `\explain plan` or `\set autotrace`, and for more information about the analysis of execution plan, refer to [SQL Execution Plan](#).

The following is an example of executing the query No.4 of TPC-H benchmark by using the `\explain plan`.

```

\explain plan
select
  o_orderpriority,
  count(*) as order_count
from
  orders
where
  o_orderdate >= date '1993-07-01'
  and o_orderdate < date '1993-07-01' + interval '3' month
  and exists (
    select
      *
    from
      lineitem
    where
      l_orderkey = o_orderkey
      and l_commitdate < l_receiptdate
  )
group by
  o_orderpriority
order by
  o_orderpriority;
O_ORDERPRIORITY ORDER_COUNT
-----
1-URGENT          10594
2-HIGH            10476

```

```

3-MEDIUM          10410
4-NOT SPECIFIED   10556
5-LOW             10487

```

```
5 rows selected.
```

```
>>> start print plan
```

```
< Execution Plan >
```

```

=====
|  IDX  |  NODE DESCRIPTION                                |      ROWS  |
-----|-----|-----|
|   0   |  SELECT STATEMENT                                |            |
|   1   |    SORT INSTANT ACCESS                          |           5 |
|   2   |      GROUP HASH INSTANT ACCESS                  |           5 |
|   3   |        NESTED LOOP JOIN (LEFT SEMI)            |        52523 |
|   4   |          TABLE ACCESS ("ORDERS")               |        57218 |
|   5   |            INDEX ACCESS ("LINEITEM, LINEITEM_PK_INDEX") |        52523 |
=====

```

```

1 - SORT KEY : "ORDERS.O_ORDERPRIORITY ASC NULLS LAST"
   RECORD COLUMNS : COUNT(*)
   READ COLUMNS : O_ORDERPRIORITY, COUNT(*)
2 - AGGREGATIONS : COUNT(*)
   GROUPING COLUMNS : O_ORDERPRIORITY
   RECORD COLUMNS : COUNT(*)
   READ COLUMNS : O_ORDERPRIORITY, COUNT(*)
3 - JOINED COLUMNS : ORDERS.O_ORDERPRIORITY
4 - READ COLUMNS : O_ORDERKEY, O_ORDERDATE, O_ORDERPRIORITY
   PHYSICAL FILTER : O_ORDERDATE >= CAST( '1993-07-01' AS DATE ) AND O_ORDERDATE < (
CAST( '1993-07-01' AS DATE ) + CAST( '3' AS INTERVAL(MONTH) ) )
5 - READ INDEX COLUMNS : L_ORDERKEY
   READ TABLE COLUMNS : L_COMMITDATE, L_RECEIPTDATE
   MIN RANGE : L_ORDERKEY = {O_ORDERKEY}
   MAX RANGE : L_ORDERKEY = {O_ORDERKEY}
   PHYSICAL TABLE FILTER : L_COMMITDATE < L_RECEIPTDATE

```

```
<<< end print plan
```

## 39.4 Command Option Reference

This chapter describes the options for performing gsql command at the shell prompt.

### Username Password

#### Description

It connects to GOLDILOCKS by using the username and password.

#### Examples

The following is an example of connecting to GOLDILOCKS with the test user.

```
% gsql test test
Connected to GOLDILOCKS Database.
gSQL>
```

The following is an example of failing to connect to GOLDILOCKS with the invalid username or password.

```
% gsql invalid_user invalid_password
ERR-28000(16004): invalid username/password; logon denied
%
```

### --as {SYSDBA|ADMIN}

#### Description

It connects to GOLDILOCKS with SYSDBA role or ADMIN role.

For more information about the description of the role, refer to **Startup and Shutdown Server**.

```
% gsql sys gliese --as sysdba
```



## Example

The following is an example of connecting to GOLDILOCKS with SYSDBA role.

```
% gsql sys gliese --as sysdba
Connected to GOLDILOCKS Database.
gSQL>
```

## --conn-string

### Description

It connects to GOLDILOCKS by using the connection string.

The details of the connection string to be described should used in a form as same as the input string of the ODBC function, **SQLDriverConnect**. For more information about the connection string, refer to **SQLDriverConnect** function.

## Example

The following is an example of connecting to GOLDILOCKS with --conn-string.

```
% gsql --conn-string 'DSN=GOLDILOCKS;UID=test;PWD=test'
Connected to GOLDILOCKS Database.
gSQL>
```

## --dsn

### Description

It connects to GOLDILOCKS by using Data Source Name (DSN) defined in the file odbc.ini.

DSN should be defined in the odbc.ini file. For more information about the odbc.ini file, refer to **DSN Configuration on UNIX**.

If DSN is omitted, the default value is GOLDILOCKS.

## Examples

The following is an example of connecting to GOLDILOCKS with DSN.

```
% gsql test test --dsn GOLDILOCKS
Connected to GOLDILOCKS Database.
gSQL>
```

The content of odbc.ini file used in the example above is as follows.

```
[GOLDILOCKS]
DATE_FORMAT = YYYY-MM-DD
TIME_FORMAT = HH24:MI:SS.FF6
```



gsql does not recognize HOST, PORT of odbc.ini file property.

## --enable-color

### Description

It outputs each row of query results in a different color on the terminal to easily distinguish them. Each row of the query results is output with a different color in an interactive mode, and it is also applied to the results of the SELECT statement included in the file by using the **--import** option.

### Examples

The following is an example of performing gsql by using the --enable-color option, then outputting the query results in an interactive mode.

```
% gsql test test --enable-color
Connected to GOLDILOCKS Database.
gSQL> SELECT id, addr FROM t1;
ID ADDR
-- -----
 1 Seoul, Korea
 2 Seoul, Korea
 3 Incheon, Korea
3 rows selected.
gSQL>
```

The following is an example of executing a SELECT query included in the file by using the --import option.

```
% gsql test test --import 'sample_select.sql' --enable-color
SELECT id, addr FROM t1;
ID ADDR
-- -----
 1 Seoul, Korea
 2 Seoul, Korea
 3 Incheon, Korea
3 rows selected.
%
```

## --help

### Description

It briefly displays the option list of gsql program.

### Example

The following is an example of using the --help option.

```
% gsql --help
Usage
  gsql [user_name [password]] [options]
Arguments:
  user_name      user name
  password       password
Options:
  --version                print version information and exit
  --import FILE            import sql FILE
  --no-prompt              suppresses the display of the banner and prompts
  --dsn DSN                dsn string (default is GOLDILOCKS)
  --conn-string 'CONN-STRING' connection string
  --prompt STRING          change prompt string
  --enable-color           enable colored text
  --as {SYSDBA|ADMIN}     privilege
  --silent                 suppresses the display of the result message and echoing of
Commands
  --help                   print help message
%
```

## --import

### Description

It performs the SQL statement which is not an interactive mode in the file in batch. The file name is enclosed in a single quote ('), and it can use an absolute or relative path.

### Examples

The following is an example of executing the SQL statement by using the absolute path of the file.

```
% gsql test test --import '/home/goldilocks/sample.sql'  
DROP TABLE IF EXISTS t1;  
Table dropped.  
CREATE TABLE t1  
(  
    id    INTEGER PRIMARY KEY,  
    name  VARCHAR(128),  
    addr  VARCHAR(128)  
);  
Table created.  
CREATE INDEX t1_idx_name ON t1(name);  
Index created.  
INSERT INTO t1  
    VALUES ( 1, 'leekmo', 'Seoul, Korea' ),  
           ( 2, 'mkkim' , 'Seoul, Korea' ),  
           ( 3, 'xcom73', 'Inchon, Korea' );  
3 rows created.  
COMMIT;  
Commit complete.  
%
```

The following is an example of executing the SQL statement by using the relative path of the file.

```
% gsql test test --import 'sample.sql'  
DROP TABLE IF EXISTS t1;  
Table dropped.  
CREATE TABLE t1  
(  
    id    INTEGER PRIMARY KEY,
```

```
name VARCHAR(128),
addr VARCHAR(128)
);
Table created.
CREATE INDEX t1_idx_name ON t1(name);
Index created.
INSERT INTO t1
VALUES ( 1, 'leekmo', 'Seoul, Korea' ),
       ( 2, 'mkkim' , 'Seoul, Korea' ),
       ( 3, 'xcom73', 'Inchon, Korea' );
3 rows created.
COMMIT;
Commit complete.
%
```

## --no-prompt

### Description

It does not output the prompt when performing an interactive mode.

### Example

The following is an example of using --no-prompt.

```
% gsql test test --no-prompt
SELECT * FROM dual;
DUMMY
-----
X
1 row selected.
```

## --prompt

### Description

It sets the gsql prompt when performing an interactive mode.

The default value is gSQL.

The special characters or spaces are enclosed in double quotes (") as follows.

```
% gsql test test --prompt "GOLDILOCKS Venus.3.2"
```

## Example

The following is an example of which the prompt is changed to GOLDILOCKS in an interactive mode by using the --prompt option.

```
% gsql test test --prompt GOLDILOCKS
Connected to GOLDILOCKS Database.
GOLDILOCKS> SELECT * FROM dual;
DUMMY
-----
X
1 row selected.
GOLDILOCKS>
```

## --silent

### Description

It does not output the results of SQL statement.

It is useful when executing large amounts of SQL statements by reading the file with --import command.

The --silent option is also applied when operating in an interactive mode.

### Example

The following is an example of executing the DictionarySchema.sql file in the \$GOLDILOCKS\_HOME/adm in directory by using the --silent option.

```
% gsql sys gliese --as sysdba --import 'DictionarySchema.sql' --silent
%
```

## --version

### Description

It outputs the version information of the gsql program.

It is recommended to use the gsql program with the version as same as the version of GOLDILOCKS. The GOLDILOCKS version can be viewed via the SQL function **VERSION** as follows.

```
gSQL> SELECT version() FROM dual;
VERSION()
-----
Release Name.X.X.X revision(XXXXX)
1 row selected.
```

### Example

The following is an example of using the --version option.

```
% gsql --version
%
```

## 39.5 Interactive Command References

All gsql-specific commands start with backslash (\) in an interactive mode.

# \\

### Syntax

| \\

### Description

It executes the most recent successfully executed SQL statement.

### Examples

```
gSQL> SELECT * FROM dual;
DUMMY
-----
X
1 row selected.
```

- It executes the most recent successfully executed SQL statement.

```
gSQL> \\
DUMMY
-----
X
1 row selected.
gSQL> SELECT * FROM invalid_table;
ERR-42000(16040): table or view does not exist :
SELECT * FROM invalid_table
          *
ERROR at line 1:
```

- It executes the most recent successfully executed SQL statement rather than executing the failed SQL statement.



```
gSQL> \\  
DUMMY  
-----  
X  
1 row selected.
```

## \connect

### Syntax

```
\connect username password [as sysdba]
```

### Description

It is newly connected with the entered username and password.  
If any uncommitted transaction exists, it performs COMMIT.

### Examples

The following is an example of connecting with the test account.

```
gSQL> \connect test test  
gSQL>
```

An error occurs if the password is invalid as follows.

```
gSQL> \connect test invalid_password  
ERR-28000(16004): invalid username/password; logon denied  
gSQL> SELECT * FROM dual;  
ERR-08003(40044): connection does not exist
```

The following is an example of connecting with the SYSDBA role.

```
gSQL> \connect sys gliese as sysdba  
gSQL>
```

# \cstartup

## Syntax

```
\cstartup  
\cstartup nomount  
\cstartup mount  
\cstartup open  
\cstartup local open  
\cstartup global open
```

## Description

It starts up GOLDILOCKS server in a cluster environment.

To execute \cstartup command, it should connect with SYSDBA role or ADMIN role. For more information about how to connect with SYSDBA role, refer to **startup and shutdown server**.

- \cstartup nomount
  - It starts up the corresponding server on NOMOUNT phase.
- \cstartup mount
  - It starts up the corresponding server on MOUNT phase.
- \cstartup local open
  - It starts up the corresponding server and other servers on LOCAL OPEN phase.
- \cstartup global open
  - It startup all servers on GLOBAL OPEN phase.
- \cstartup open
  - It is as same as \cstartup global open.
- \cstartup
  - It is as same as \cstartup global open.

\cstartup local open command and \cstartup global open command startup the corresponding server and other servers to the corresponding phase. Other commands are applied only to the corresponding server, so the server should be started up to LOCAL OPEN phase for the multi-level startup using **ALTER SYSTEM {MOUNT | OPEN} DATABASE**.

The server startup phases are classified as NOMOUNT, MOUNT, LOCAL OPEN, GLOBAL OPEN. For more information, refer to **multi-level startup**.

**ALTER SYSTEM {MOUNT | OPEN} DATABASE** should be performed to move on to the next phase after executing \cstartup command.

\cstartup using glocator can be viewed via **CSTARTUP** and **CSHUTDOWN**.



- It is command used only in a C/S environment. It can be used only in gsqlnet.
- Commands other than \cstartup nomount/ mount affects on the corresponding server and other servers. Therefore, if LOCATOR\_DSN is not specified in **odbc.ini file**, then an error occurs.

## Example

The following is an example of starting up GOLDILOCKS.

```
% gsqlnet sys gliese --as sysdba
Connected to an idle instance.
gSQL> \cstartup
Startup success
```

## \cshutdown

### Syntax

```
\cshutdown
\cshutdown abort
\cshutdown normal
```

### Description

It shuts down GOLDILOCKS server in a cluster environment.

To execute \cshutdown command, it should connect with SYSDBA role or ADMIN role. For more information about how to connect with SYSDBA role, refer to **startup and shutdown server**.

- \cshutdown normal
  - It blocks an access of a new session, waits for all connected sessions to be terminated, executes a checkpoint, then terminates the server.
- \cshutdown abort
  - It forcibly and immediately terminates the server regardless of the status of connected sessions.
- \cshutdown
  - It is as same as \cshutdown normal.

\cshutdown using glocator can be viewed via **CSTARTUP** and **CSHUTDOWN**.



- It is command used only in a C/S environment. It can be used only in gsqlnet.
- Commands other than \cshutdown affects on the corresponding server and other servers. The refore, if LOCATOR\_DSN is not specified in **odbc.ini file**, then an error occurs.

## Example

The following is an example of shutting down GOLDILOCKS.

```
% gsqlnet sys gliese --as sysdba
Connected to GOLDILOCKS Database.
gSQL> \cshutdown
Shutdown success
gSQL>
```

## \ddl\_cluster

### Syntax

```
\ddl_cluster
```

### Description

It outputs a cluster DDL corresponding to the current status of a cluster system. This statement is valid in a cluster system.

### Example

The following is an example of executing \ddl\_cluster command for a cluster system consisting as 3 x 2.

```
gSQL> \ddl_cluster
SET SESSION AUTHORIZATION "SYS";
CREATE CLUSTER GROUP "G1"
    CLUSTER MEMBER "G1N1" HOST '127.0.0.1' PORT '10110'
;
COMMIT;
SET SESSION AUTHORIZATION "SYS";
```

```
ALTER CLUSTER GROUP "G1" ADD
    CLUSTER MEMBER "G1N2" HOST '127.0.0.1' PORT '10120'
;
COMMIT;
SET SESSION AUTHORIZATION "SYS";
CREATE CLUSTER GROUP "G2"
    CLUSTER MEMBER "G2N1" HOST '127.0.0.1' PORT '10210'
;
COMMIT;
SET SESSION AUTHORIZATION "SYS";
ALTER CLUSTER GROUP "G2" ADD
    CLUSTER MEMBER "G2N2" HOST '127.0.0.1' PORT '10220'
;
COMMIT;
SET SESSION AUTHORIZATION "SYS";
CREATE CLUSTER GROUP "G3"
    CLUSTER MEMBER "G3N1" HOST '127.0.0.1' PORT '10310'
;
COMMIT;
SET SESSION AUTHORIZATION "SYS";
ALTER CLUSTER GROUP "G3" ADD
    CLUSTER MEMBER "G3N2" HOST '127.0.0.1' PORT '10320'
;
```

## \ddl\_db

### Syntax

```
\ddl_db
\ddl_db GRANT
\ddl_db COMMENT
```

### Description

It outputs the DDL statements corresponding to the current state of the database object.



The objects stored in the recycle bin are not output.

**Table 39-19** \ddl\_db commands

Command	Description
\ddl_db	It outputs the DDL statements of all objects created in the database.
\ddl_db GRANT	It outputs the GRANT .. ON DATABASE statement corresponding to the privilege information on the database object.
\ddl_db COMMENT	It outputs the COMMENT ON DATABASE statement corresponding to the comment information on the database object.

The result of \ddl\_db command without any option outputs the DDL statements in the following order.

- Database DDL
- Tablespace DDL
- Profile DDL
- Authorization DDL
- Schema DDL
- Authorization schema path DDL
- Database privilege DDL
- Tablespace privilege DDL
- Schema privilege DDL
- Public synonym DDL
- Table DDL
- Table privilege DDL
- Table option DDL
- Constraint DDL
- Index DDL
- View DDL
- View privilege DDL
- Sequence DDL
- Sequence privilege DDL
- Synonym DDL
- Stored procedure/ function DDL
- Package DDL
- Audit policy DDL

However, the information related to the following schemas which include the dictionary information are not output.

- DICTIONARY\_SCHEMA
- INFORMATION\_SCHEMA
- PERFORMANCE\_VIEW\_SCHEMA
- DEFINITION\_SCHEMA
- FIXED\_TABLE\_SCHEMA

The DDL statement for the schema above which includes the dictionary information can be output by using `\ddl_schema`.

## Examples

The following is an example of executing `\ddl_db`.

```
gSQL> \ddl_db
```

- Database DDL

```
SET SESSION AUTHORIZATION "SYS";  
COMMENT  
  ON DATABASE  
  IS 'goldilocks database'  
;
```

- Tablespace DDL

```
SET SESSION AUTHORIZATION "SYS";  
CREATE MEMORY DATA TABLESPACE "TEST_TBS"  
  DATAFILE '/home/GOLDILOCKS/workspace/product/Gliese/home/db/test1.dbf'  
  SIZE 10477568 REUSE  
  ONLINE  
  LOGGING  
  EXTSIZE 262144  
;  
SET SESSION AUTHORIZATION "SYS";  
ALTER TABLESPACE "TEST_TBS"  
  ADD DATAFILE '/home/GOLDILOCKS/workspace/product/Gliese/home/db/test2.dbf'  
  SIZE 10477568 REUSE  
;  
SET SESSION AUTHORIZATION "SYS";  
ALTER TABLESPACE "TEST_TBS"  
  ADD DATAFILE '/home/GOLDILOCKS/workspace/product/Gliese/home/db/test3.dbf'  
  SIZE 10477568 REUSE  
;  
SET SESSION AUTHORIZATION "SYS";  
COMMENT  
  ON TABLESPACE "TEST_TBS"  
  IS 'comment tablespace TPC data'  
;
```

```

SET SESSION AUTHORIZATION "SYS";
CREATE MEMORY TEMPORARY TABLESPACE "TEMP_TBS"
    MEMORY 'test_mem'
        SIZE 10477568
        EXTSIZE 262144
;
... Ellipsis ...

```

- Sequence privilege DDL

```

SET SESSION AUTHORIZATION "H_USER";
GRANT
    USAGE ON SEQUENCE "H_USER"."H_SEQ"
    TO "PUBLIC"
;
SET SESSION AUTHORIZATION "H_USER";
GRANT
    USAGE ON SEQUENCE "H_USER"."H_SEQ"
    TO "TEST"
    WITH GRANT OPTION
;
SET SESSION AUTHORIZATION "H_USER";
GRANT
    USAGE ON SEQUENCE "H_USER"."H_SEQ"
    TO "C_USER"
;
SET SESSION AUTHORIZATION "C_USER";
GRANT
    USAGE ON SEQUENCE "C_USER"."C_SEQ"
    TO "TEST"
;
SET SESSION AUTHORIZATION "C_USER";
GRANT
    USAGE ON SEQUENCE "C_USER"."C_SEQ"
    TO "H_USER"
;

```

The following is an example of executing `\ddl_db GRANT`.

```

gSQL> \ddl_db GRANT
SET SESSION AUTHORIZATION "SYS";
GRANT

```



```

ALTER DATABASE ON DATABASE
TO "TEST"
WITH GRANT OPTION
;
SET SESSION AUTHORIZATION "SYS";
GRANT
    ALTER SYSTEM ON DATABASE
    TO "TEST"
    WITH GRANT OPTION
;
... Ellipsis ...

```

## \ddl\_tablespace

### Syntax

```

\ddl_tablespace name
\ddl_tablespace name CREATE
\ddl_tablespace name ALTER
\ddl_tablespace name TABLE
\ddl_tablespace name CONSTRAINT
\ddl_tablespace name INDEX
\ddl_tablespace name GRANT
\ddl_tablespace name COMMENT

```

### Description

It outputs the DDL statements for the current state of the tablespace object.



The objects stored in the recycle bin are not output.

**Table 39-20** \ddl\_tablespace commands

Command	Description
\ddl_tablespace name	It performs all options below.
\ddl_tablespace name CREATE	It outputs the CREATE TABLESPACE statement of the tablespace object.
\ddl_tablespace name ALTER	It outputs the ALTER TABLESPACE statements for the datafile or memory added to the tablespace.
\ddl_tablespace name TABLE	It outputs the CREATE TABLE statements of the tables stored in the tablespace.

Command	Description
<code>\ddl_tablespace name CONSTRAINT</code>	It outputs the ALTER TABLE statements of the constraints stored in the tablespace.
<code>\ddl_tablespace name INDEX</code>	It outputs the CREATE INDEX statements of the indexes stored in the tablespace.
<code>\ddl_tablespace name GRANT</code>	It outputs the GRANT .. ON TABLESPACE statement for the privilege information on the tablespace.
<code>\ddl_tablespace name COMMENT</code>	It outputs the COMMENT ON TABLESPACE statement corresponding to the comment on the tablespace.

## Examples

The following is an example of executing `\ddl_tablespace CREATE`.

```
gSQL> \ddl_tablespace test_tbs CREATE
SET SESSION AUTHORIZATION "SYS";
CREATE MEMORY DATA TABLESPACE "TEST_TBS"
  DATAFILE '/home/GOLDILOCKS/workspace/product/Gliese/home/db/test1.dbf'
  SIZE 10477568 REUSE
  ONLINE
  EXTSIZE 262144
;
```

The following is an example of executing `\ddl_tablespace ALTER`.

```
gSQL> \ddl_tablespace test_tbs ALTER
SET SESSION AUTHORIZATION "SYS";
ALTER TABLESPACE "TEST_TBS"
  ADD DATAFILE
    '/home/GOLDILOCKS/workspace/product/Gliese/home/db/test2.dbf'
  SIZE 10477568 REUSE
  ,
  '/home/GOLDILOCKS/workspace/product/Gliese/home/db/test3.dbf'
  SIZE 10477568 REUSE
;
```

## `\ddl_profile`

## Syntax

```
\ddl_profile name
\ddl_profile name CREATE
\ddl_profile name COMMENT
```

## Description

It outputs the DDL statement for the current state of the profile object.

**Table 39-21** \ddl\_profile commands

Command	Description
\ddl_profile name	It performs all options below.
\ddl_profile name CREATE	It outputs the CREATE PROFILE statement of the profile object.
\ddl_profile name COMMENT	It outputs the COMMENT ON PROFILE statement corresponding to the comment on the profile.

## Example

The following is an example of executing \ddl\_profile CREATE.

```
gSQL> \ddl_profile prof1 CREATE
SET SESSION AUTHORIZATION "SYS";
CREATE PROFILE "PROF1" LIMIT
    FAILED_LOGIN_ATTEMPTS  DEFAULT
    PASSWORD_LOCK_TIME     1/86400
    PASSWORD_LIFE_TIME      UNLIMITED
    PASSWORD_GRACE_TIME     100
    PASSWORD_REUSE_MAX      DEFAULT
    PASSWORD_REUSE_TIME     DEFAULT
    PASSWORD_VERIFY_FUNCTION KISA_VERIFY_FUNCTION
;
COMMIT;
```

## \ddl\_audit\_policy

## Syntax

```
\ddl_audit_policy name
\ddl_audit_policy name CREATE
\ddl_audit_policy name AUDIT
\ddl_audit_policy name COMMENT
```

## Description

It outputs the DDL statement for the current state of the audit policy object.



The objects stored in the recycle bin are not output.

**Table 39-22** \ddl\_audit\_policy commands

Command	Description
\ddl_audit_policy name	It perform all options below.
\ddl_audit_policy name CREATE	It outputs CREATE AUDIT POLICY statement of the audit policy object.
\ddl_audit_policy name AUDIT	It outputs AUDIT POLICY statement of the audit policy object.
\ddl_audit_policy name COMMENT	It outputs the COMMENT ON AUDIT POLICY statement corresponding to the comment on the audit policy.

## Examples

The following is an example of executing \ddl\_audit\_policy CREATE.

```
gSQL> \ddl_audit_policy p1 CREATE
SET SESSION AUTHORIZATION "SYS";
CREATE AUDIT POLICY "P1"
    ACTIONS SELECT ON "PUBLIC"."T1"
        , INSERT ON "PUBLIC"."T1"
        , UPDATE ON "PUBLIC"."T2"
        , ALL ON "PUBLIC"."SEQ1"
        , SELECT ON "PUBLIC"."SEQ2"
        , EXECUTE ON "PUBLIC"."FUNC2"
;
COMMIT;
```

# \ddl\_auth

## Syntax

```

\ddl_auth name
\ddl_auth name CREATE
\ddl_auth name SCHEMA PATH
\ddl_auth name SCHEMA
\ddl_auth name TABLE
\ddl_auth name CONSTRAINT
\ddl_auth name INDEX
\ddl_auth name VIEW
\ddl_auth name SEQUENCE
\ddl_auth name SYNONYM
\ddl_auth name PROCEDURE
\ddl_auth name PACKAGE
\ddl_auth name COMMENT

```

## Description

It outputs the DDL statements for the current state of the account object.



The objects stored in the recycle bin are not output.

**Table 39-23** \ddl\_auth commands

Command	Description
\ddl_auth name	It performs all options below.
\ddl_auth name CREATE	It outputs the CREATE USER statement of the user object.
\ddl_auth name SCHEMA	It outputs the CREATE SCHEMA statement of schemas owned by a user.
\ddl_auth name SCHEMA PATH	It outputs the ALTER USER statement corresponding to the schema path of the account.
\ddl_auth name TABLE	It outputs the CREATE TABLE statements of tables owned by a user.
\ddl_auth name CONSTRAINT	It outputs the ALTER TABLE statements of constraints owned by a user.
\ddl_auth name INDEX	It outputs the CREATE INDEX statements of indexes owned by a user.
\ddl_auth name VIEW	It outputs the CREATE VIEW statements of views owned by a user.
\ddl_auth name SEQUENCE	It outputs the CREATE SEQUENCE statements of sequences owned by a user.
\ddl_auth name SYNONYM	It outputs the CREATE SYNONYM statements of synonyms owned by a user.
\ddl_auth name PROCEDURE	It outputs the CREATE PROCEDURE/ FUNCTION statements of procedures and functions owned by a user.

Command	Description
<code>\ddl_auth name PACKAGE</code>	It outputs the CREATE PACKAGE/PACKAGE BODY statements of packages owned by a user.
<code>\ddl_auth name COMMENT</code>	It outputs the COMMENT ON AUTHORIZATION statement corresponding to comments on the account.

## Examples

The following is an example of executing `\ddl_auth CREATE`.

```
gSQL> \ddl_auth h_user CREATE
SET SESSION AUTHORIZATION "SYS";
CREATE USER "H_USER"
  IDENTIFIED BY H_USER
  DEFAULT TABLESPACE "TEST_TBS"
  TEMPORARY TABLESPACE "TEMP_TBS"
  WITHOUT SCHEMA
;
```

The following is an example of executing `\ddl_auth SCHEMA`.

```
gSQL> \ddl_auth h_user SCHEMA
SET SESSION AUTHORIZATION "SYS";
CREATE SCHEMA "H_USER"
  AUTHORIZATION "H_USER"
;
```

The following is an example of executing `\ddl_auth TABLE`.

```
gSQL> \ddl_auth h_user TABLE
SET SESSION AUTHORIZATION "H_USER";
CREATE TABLE "H_USER"."REGION"
  (
    "R_REGIONKEY" NUMBER( 10, 0 )
  , "R_NAME" CHARACTER( 25 OCTETS )
  , "R_COMMENT" CHARACTER VARYING( 152 OCTETS )
  )
PCTFREE 10
PCTUSED 60
INITRANS 4
MAXTRANS 8
```

```

STORAGE
(
    INITIAL 524288
    NEXT    262144
    MINSIZE 524288
    MAXSIZE 562949953159168
)
TABLESPACE "TEST_TBS"
;
SET SESSION AUTHORIZATION "H_USER";
CREATE TABLE "H_USER"."NATION"
(
    "N_NATIONKEY" NUMBER( 10, 0 )
    , "N_NAME" CHARACTER( 25 OCTETS )
    , "N_REGIONKEY" NUMBER( 10, 0 )
    , "N_COMMENT" CHARACTER VARYING( 152 OCTETS )
)
PCTFREE 10
PCTUSED 60
INITTRANS 4
MAXTRANS 8
STORAGE
(
    INITIAL 524288
    NEXT    262144
    MINSIZE 524288
    MAXSIZE 562949953159168
)
TABLESPACE "TEST_TBS"
;

```

## \ddl\_schema

### Syntax

```

\ddl_schema name
\ddl_schema name CREATE
\ddl_schema name TABLE
\ddl_schema name CONSTRAINT

```

```

\ddl_schema name INDEX
\ddl_schema name VIEW
\ddl_schema name SEQUENCE
\ddl_schema name SYNONYM
\ddl_schema name PROCEDURE
\ddl_schema name PACKAGE
\ddl_schema name GRANT
\ddl_schema name COMMENT

```

## Description

It outputs the DDL statements for the current state of the schema object.



The objects stored in the recycle bin are not output.

**Table 39-24** \ddl\_schema commands

Command	Description
\ddl_schema name	It performs all options below.
\ddl_schema name CREATE	It outputs the CREATE SCHEMA statement of the schema object.
\ddl_schema name TABLE	It outputs the CREATE TABLE statements of the tables which belong to the schema.
\ddl_schema name CONSTRAINT	It outputs the ALTER TABLE statements of the constraints which belong to the schema.
\ddl_schema name INDEX	It outputs the CREATE INDEX statements of the indexes which belong to the schema.
\ddl_schema name VIEW	It outputs the CREATE VIEW statements of the views which belong to the schema.
\ddl_schema name SEQUENCE	It outputs the CREATE SEQUENCE statements of the sequences which belong to the schema.
\ddl_schema name SYNONYM	It outputs the CREATE SYNONYM statements of the synonyms which belong to the schema.
\ddl_schema name PROCEDURE	It outputs the CREATE PROCEDURE/ FUNCTION statements of the procedures and functions which belong to the schema.
\ddl_schema name PACKAGE	It outputs the CREATE PACKAGE/PACKAGE BODY statements of the package which belong to the schema.
\ddl_schema name GRANT	It outputs the GRANT .. ON SCHEMA statement for the privilege information on the schema.
\ddl_schema name COMMENT	It outputs the COMMENT ON SCHEMA statement corresponding to the comment on the schema.



## Examples

The following is an example of executing `\ddl_schema CREATE`.

```
gSQL> \ddl_schema h_user CREATE
SET SESSION AUTHORIZATION "SYS";
CREATE SCHEMA "H_USER"
    AUTHORIZATION "H_USER"
;
```

The following is an example of executing `\ddl_schema CONSTRAINT`.

```
gSQL> \ddl_schema h_user CONSTRAINT
SET SESSION AUTHORIZATION "H_USER";
ALTER TABLE "H_USER"."REGION"
    ADD CONSTRAINT "H_USER"."REGION_PK"
    PRIMARY KEY
    (
        "R_REGIONKEY" ASC NULLS LAST
    )
    INDEX "REGION_PK_INDEX"
    PCTFREE 10
    INITRANS 4
    MAXTRANS 8
    STORAGE
    (
        INITIAL 524288
        NEXT 262144
        MINSIZE 524288
        MAXSIZE 562949953159168
    )
    TABLESPACE "TEMP_TBS"
    NOT DEFERRABLE
    INITIALLY IMMEDIATE
;
SET SESSION AUTHORIZATION "H_USER";
ALTER TABLE "H_USER"."NATION"
    ADD CONSTRAINT "H_USER"."NATION_PK"
    PRIMARY KEY
    (
        "N_NATIONKEY" ASC NULLS LAST
    )
```

```
INDEX "NATION_PK_INDEX"
PCTFREE 10
INITRANS 4
MAXTRANS 8
STORAGE
(
  INITIAL 524288
  NEXT 262144
  MINSIZE 524288
  MAXSIZE 562949953159168
)
TABLESPACE "TEMP_TBS"
NOT DEFERRABLE
INITIALLY IMMEDIATE
;
SET SESSION AUTHORIZATION "H_USER";
ALTER TABLE "H_USER"."SUPPLIER"
  ADD CONSTRAINT "H_USER"."SUPPLIER_PK"
  PRIMARY KEY
  (
    "S_SUPPKEY" ASC NULLS LAST
  )
INDEX "SUPPLIER_PK_INDEX"
PCTFREE 10
INITRANS 4
MAXTRANS 8
STORAGE
(
  INITIAL 524288
  NEXT 262144
  MINSIZE 524288
  MAXSIZE 562949953159168
)
TABLESPACE "TEMP_TBS"
NOT DEFERRABLE
INITIALLY IMMEDIATE
;
```

## \ddl\_public\_synonym

### Syntax

```
\ddl_public_synonym name
\ddl_public_synonym name CREATE
```

### Description

It outputs the DDL statements for the current state of the public synonym object.

**Table 39-25** \ddl\_public\_synonym commands

Command	Description
\ddl_public_synonym	It performs all options below.
\ddl_public_synonym name CREATE	It outputs the CREATE PUBLIC SYNONYM statement of the public synonym object.

### Example

The following is an example of executing \ddl\_public\_synonym CREATE.

```
gSQL> \ddl_public_synonym pubsyn CREATE
SET SESSION AUTHORIZATION "SYS";
CREATE PUBLIC SYNONYM "PUBSYN" FOR "PUBLIC"."T1"
;
COMMIT;
```

## \ddl\_table

### Syntax

```
\ddl_table name
\ddl_table name CREATE
\ddl_table name CONSTRAINT
\ddl_table name INDEX
\ddl_table name IDENTITY
\ddl_table name SUPPLEMENTAL
\ddl_table name GRANT
```

`\ddl_table name COMMENT`

## Description

It outputs the DDL statements for the current state of the table object.



The objects stored in the recycle bin are not output.

**Table 39-26** \ddl\_table commands

Command	Description
<code>\ddl_table name</code>	It performs all options below.
<code>\ddl_table name CREATE</code>	It outputs the CREATE TABLE statement of the table object.
<code>\ddl_table name CONSTRAINT</code>	It outputs the ALTER TABLE statements of the constraints created in the table.
<code>\ddl_table name INDEX</code>	It outputs the CREATE INDEX statements of the indexes created in the table.
<code>\ddl_table name IDENTITY</code>	It outputs the ALTER TABLE statement for the restart value if the table has an identity column.
<code>\ddl_table name SUPPLEMENTAL</code>	It outputs the ALTER TABLE statement if the supplemental log option is set on the table.
<code>\ddl_table name GRANT</code>	It outputs the GRANT .. ON TABLE statement for the privilege information on the table.
<code>\ddl_table name COMMENT</code>	It outputs the COMMENT ON TABLE statement corresponding to the comment on the table.

## Examples

The following is an example of executing `\ddl_table CREATE`.

```
gSQL> \ddl_table h_user.orders CREATE
SET SESSION AUTHORIZATION "H_USER";
CREATE TABLE "H_USER"."ORDERS"
(
    "O_ORDERKEY" NUMBER( 10, 0 )
    , "O_CUSTKEY" NUMBER( 10, 0 )
    , "O_ORDERSTATUS" CHARACTER( 1 OCTETS )
    , "O_TOTALPRICE" NUMBER( 12, 2 )
    , "O_ORDERDATE" DATE
    , "O_ORDERPRIORITY" CHARACTER( 15 OCTETS )
    , "O_CLERK" CHARACTER( 15 OCTETS )
    , "O_SHIPPRIORITY" NUMBER( 10, 0 )
    , "O_COMMENT" CHARACTER VARYING( 79 OCTETS )
```

```

)
PCTFREE 10
PCTUSED 60
INITTRANS 4
MAXTRANS 8
STORAGE
(
    INITIAL 524288
    NEXT 262144
    MINSIZE 524288
    MAXSIZE 562949953159168
)
TABLESPACE "TEST_TBS"
;

```

The following is an example of executing `\ddl_table GRANT`.

```

gSQL> \ddl_table h_user.nation GRANT
SET SESSION AUTHORIZATION "H_USER";
GRANT
    DELETE ON TABLE "H_USER"."NATION"
    TO "TEST"
;
SET SESSION AUTHORIZATION "H_USER";
GRANT
    SELECT ( "N_NATIONKEY" ) ON TABLE "H_USER"."NATION"
    TO "C_USER"
;
SET SESSION AUTHORIZATION "H_USER";
GRANT
    SELECT ( "N_NAME" ) ON TABLE "H_USER"."NATION"
    TO "C_USER"
;

```

## `\ddl_constraint`

## Syntax

```
\ddl_constraint name
\ddl_constraint name ALTER
\ddl_constraint name COMMENT
```

## Description

It outputs the DDL statements for the current state of the constraint object.



The objects stored in the recycle bin are not output.

**Table 39-27** \ddl\_constraint commands

Command	Description
\ddl_constraint name	It performs all options below.
\ddl_constraint name ALTER	It outputs the ALTER TABLE statement of the constraint object.
\ddl_constraint name COMMENT	It outputs the COMMENT ON CONSTRAINT statement corresponding to the comment on the constraint.

## Example

The following is an example of executing \ddl\_constraint ALTER.

```
gSQL> \ddl_constraint h_user.lineitem_pk ALTER
SET SESSION AUTHORIZATION "H_USER";
ALTER TABLE "H_USER"."LINEITEM"
  ADD CONSTRAINT "H_USER"."LINEITEM_PK"
  PRIMARY KEY
  (
    "L_ORDERKEY" ASC NULLS LAST
  , "L_LINENUMBER" ASC NULLS LAST
  )
  INDEX "LINEITEM_PK_INDEX"
  PCTFREE 10
  INITRANS 4
  MAXTRANS 8
  STORAGE
  (
    INITIAL 524288
```

```

        NEXT 262144
        MINSIZE 524288
        MAXSIZE 562949953159168
    )
    TABLESPACE "TEMP_TBS"
    NOT DEFERRABLE
    INITIALLY IMMEDIATE
;

```

## \ddl\_index

### Syntax

```

\ddl_index name
\ddl_index name CREATE
\ddl_index name COMMENT

```

### Description

It outputs the DDL statements for the current state of the index object.



The objects stored in the recycle bin are not output.

**Table 39-28** \ddl\_index commands

Command	Description
\ddl_index name	It performs all options below.
\ddl_index name CREATE	It outputs the CREATE INDEX statement of the index object.
\ddl_index name COMMENT	It outputs the COMMENT ON INDEX statement corresponding to the comment on the index.

### Example

The following is an example of executing \ddl\_index CREATE.

```

gSQL> \ddl_index public.idx2 CREATE
SET SESSION AUTHORIZATION "TEST";
CREATE INDEX "PUBLIC"."IDX2"
ON "PUBLIC"."T1"

```

```

(
    "C3" ASC NULLS LAST
    , "C1" DESC NULLS FIRST
)
PCTFREE 10
INITRANS 4
MAXTRANS 8
STORAGE
(
    INITIAL 524288
    NEXT 262144
    MINSIZE 524288
    MAXSIZE 562949953159168
)
TABLESPACE "MEM_TEMP_TBS"
;

```

## \ddl\_view

### Syntax

```

\ddl_view name
\ddl_view name CREATE
\ddl_view name GRANT
\ddl_view name COMMENT

```

### Description

It outputs the DDL statements for the current state of the view object.

**Table 39-29** \ddl\_view commands

Command	Description
\ddl_view name	It performs all options below.
\ddl_view name CREATE	It outputs the CREATE VIEW statement of the view object.
\ddl_view name GRANT	It outputs the GRANT .. ON TABLE statement for the privilege information on the view.
\ddl_view name COMMENT	It outputs the COMMENT ON TABLE corresponding to the comment on the view.



## Example

The following is an example of executing `\ddl_view CREATE`.

```
gSQL> \ddl_view h_user.revenue CREATE
SET SESSION AUTHORIZATION "H_USER";
CREATE OR REPLACE FORCE VIEW "H_USER"."REVENUE"
  (supplier_no, total_revenue)
AS SELECT
  l_suppkey,
  ROUND( sum(l_extendedprice * (1 - l_discount)), 2)
FROM
  lineitem
WHERE
  l_shipdate >= date '1996-01-01'
  AND l_shipdate < date '1996-01-01' + interval '3' month
GROUP BY
  l_suppkey
;
```

## \ddl\_sequence

### Syntax

```
\ddl_sequence name
\ddl_sequence name CREATE
\ddl_sequence name RESTART
\ddl_sequence name GRANT
\ddl_sequence name COMMENT
```

### Description

It outputs the DDL statements for the current state of the sequence object.

**Table 39-30** \ddl\_sequence commands

Command	Description
\ddl_sequence name	It performs all options below.
\ddl_sequence name CREATE	It outputs the CREATE SEQUENCE statement of the sequence object.
\ddl_sequence name RESTART	It outputs the ALTER SEQUENCE statement corresponding to the restart value of the

Command	Description
	sequence object.
<code>\ddl_sequence name GRANT</code>	It outputs the GRANT .. ON SEQUENCE statement for the privilege information on the sequence.
<code>\ddl_sequence name COMMENT</code>	It outputs the COMMENT ON SEQUENCE statement corresponding to the comment on the sequence.

## Examples

The following is an example of executing `\ddl_sequence CREATE`.

```
gSQL> \ddl_sequence h_user.h_seq CREATE
SET SESSION AUTHORIZATION "H_USER";
CREATE SEQUENCE "H_USER"."H_SEQ"
    START WITH 1
    INCREMENT BY 1
    MAXVALUE 9223372036854775807
    MINVALUE 1
    NO CYCLE
    CACHE 20
;
```

The following is an example of executing `\ddl_sequence RESTART`.

```
gSQL> \ddl_sequence h_user.h_seq RESTART
SET SESSION AUTHORIZATION "H_USER";
ALTER SEQUENCE "H_USER"."H_SEQ"
    RESTART WITH 21
;
```

## `\ddl_synonym`

### Syntax

```
\ddl_synonym name
\ddl_synonym name CREATE
```

## Description

It outputs the DDL statements for the current state of the synonym object.

**Table 39-31** \ddl\_synonym commands

Command	Description
\ddl_synonym	It performs all options below.
\ddl_synonym name CREATE	It outputs the CREATE SYNONYM statement of the synonym object.

## Example

The following is an example of executing \ddl\_synonym CREATE.

```
gSQL> \ddl_synonym syn CREATE
SET SESSION AUTHORIZATION "TEST";
CREATE SYNONYM "PUBLIC"."SYN" FOR "PUBLIC"."T1"
;
COMMIT;
```

## \ddl\_procedure

### Syntax

```
\ddl_procedure name
\ddl_procedure name CREATE
```

## Description

It outputs the DDL statements for the current state of the stored procedure or the function object.

**Table 39-32** \ddl\_procedure commands

Command	Description
\ddl_procedure	It performs all options below.
\ddl_procedure name CREATE	It outputs CREATE PROCEDURE/ FUNCTION statement of the stored procedure/ function object.

## Example

The following is an example of executing `\ddl_procedure CREATE`.

```
gSQL> \ddl_procedure proc1 CREATE
SET SESSION AUTHORIZATION "TEST";
CREATE OR REPLACE PROCEDURE "PUBLIC"."PROC1"
is
begin
  null;
end;
/
COMMIT;
```

## \ddl\_package

### Syntax

```
\ddl_package name
\dddl_package name CREATE
```

### Description

It outputs the DDL statements for the current state of the package spec or the package body object.

**Table 39-33** \ddl\_package commands

Command	Description
<code>\ddl_package</code>	It performs all options below.
<code>\ddl_package name CREATE</code>	It outputs CREATE PACKAGE/PACKAGE BODY statement of the package spec and the package body object.

### Examples

The following is an example of executing `\ddl_package CREATE`.

```
gSQL> \ddl_package pkg1 CREATE
SET SESSION AUTHORIZATION "TEST";
CREATE OR REPLACE PACKAGE "PUBLIC"."PKG1"
is
```

```

    v1 integer;
    procedure proc1( a1 integer );
end;
/
CREATE OR REPLACE PACKAGE BODY "PUBLIC"."PKG1"
is
    procedure proc1( a1 integer )
    is
    begin
        null;
    end;
end;
/
COMMIT;

```

## \desc

### Syntax

```

\desc table_name
\desc schema_name.table_name

```

### Description

It queries the structure information of the table.

A table may be described only with the table name as follows or described together with the schema name. If the schema name is not specified, the schema name of the table is determined by the **Schema Path** of the user.

- \desc t1
- \desc public.t1

If a table name is created by using **Identifiers** when creating a table as follows, the double quotes (") is used to describe it.

- Creating a table
  - CREATE TABLE "TaBle#@^\*" ( id INTEGER );
- \desc "TaBle#@^"
- \desc "PUBLIC"."TaBle#@^"

The execution result includes the following information of the table.

- Column information
  - Column name
  - Data type
  - Whether NULL is allowed
- Index information
  - Index name
  - Storage space for index
  - Index type
  - Whether UNIQUE is allowed
  - Key column name
- Constraint information
  - Constraint name
  - Constraint type
  - The related index
  - Constraint column

## Examples

The following is an example of querying the information of the t1 table.

```
gSQL> \desc t1
COLUMN_NAME TYPE                IS_NULLABLE
-----
ID          NUMBER(10,0)                FALSE
NAME       CHARACTER VARYING(128)     TRUE
ADDR       CHARACTER VARYING(1024)   TRUE
INDEX_NAME TABLESPACE_NAME INDEX_TYPE IS_UNIQUE COLUMNS
-----
T1_PRIMARY_KEY_INDEX MEM_TEMP_TBS BTREE TRUE ID
T1_IDX_NAME MEM_TEMP_TBS BTREE FALSE NAME
CONSTRAINT_NAME CONSTRAINT_TYPE ASSOCIATED_INDEX COLUMNS
-----
T1_PRIMARY_KEY PRIMARY KEY T1_PRIMARY_KEY_INDEX ID
```

The following is an example of querying the information of the t1 table by describing together with the schema name public.

```
gSQL> \desc public.t1
COLUMN_NAME TYPE                IS_NULLABLE
-----
```

```

ID          NUMBER(10,0)          FALSE
NAME        CHARACTER VARYING(128) TRUE
ADDR        CHARACTER VARYING(1024) TRUE
INDEX_NAME  TABLESPACE_NAME INDEX_TYPE IS_UNIQUE COLUMNS
-----
T1_PRIMARY_KEY_INDEX MEM_TEMP_TBS BTREE TRUE ID
T1_IDX_NAME MEM_TEMP_TBS BTREE FALSE NAME
CONSTRAINT_NAME CONSTRAINT_TYPE ASSOCIATED_INDEX COLUMNS
-----
T1_PRIMARY_KEY PRIMARY KEY T1_PRIMARY_KEY_INDEX ID

```

The following is an example of querying the information of the table created by using the delimited identifier.

```

gSQL> CREATE TABLE "Table#@^*" ( id INTEGER );
Table created.
gSQL> \desc "Table#@^*"
COLUMN_NAME TYPE          IS_NULLABLE
-----
ID          NUMBER(10,0) TRUE

```

If the delimited identifier is not used as follows, then an error occurs.

```

gSQL> \desc Table#@^*
ERR-42000(40000): syntax error
\desc Table#@^*
..... ^ ^
Error at line 1

```

## `\dynamic sql :var`

### Syntax

```
\dynamic sql :var
```

### Description

It executes the SQL statement stored in the host variable var.

It is similar in concept to **Embedded Dynamic SQL** which executes SQL statements that are not defined in

an embedded SQL, but It is used when performing SQL statement which is not defined.

It is performed in the following order.

1. Declare a host variable. (Refer to `\var`.)  
`\var var_stmt VARCHAR(1024)`
2. Assign an SQL statement as the value of the host variable. (Refer to `\exec :var := value`.)  
`\exec :var_stmt := 'SELECT # FROM t1'`
3. Execute the dynamic SQL.  
`\dynamic sql :var_stmt`

## Examples

The following is an example of declaring the `var_stmt` host variable and executing the dynamic SQL by assigning an SQL statement.

- Assigning the SELECT statement to the host variable

```
gSQL> \exec :var_stmt := 'SELECT * FROM t1'
```

- Executing the dynamic SQL

```
gSQL> \dynamic sql :var_stmt
ID NAME  ADDR
-- -----
 1 leekmo Seoul, Korea
1 row selected.
```

Two single quote (') are described like as the usage of the `\exec :var := value` command when a string exists in an SQL statement as the INSERT statement below.

- Declaring a host variable

```
gSQL> \var var_stmt VARCHAR(1024)
```

- Assigning the INSERT statement to the host variable

```
gSQL> \exec :var_stmt := 'INSERT INTO t1(id, name, addr) VALUES ( 1, ''leekmo'', ''Seoul, Korea'' )'
```

- Executing the dynamic SQL.



```
gSQL> \dynamic sql :var_stmt  
1 row created.
```

## \edit

### Description

It edits the SQL statement by using the text editor. The used text editor is specified in the EDITOR environment variable, and if the EDITOR environment variable does not exist, vi is used by default.

When using the editing feature, gsql hands over control by executing the editor. The user can freely edit the SQL statements with the editor. When the editor ends, the control is handed over to gsql, and its content will be added as the last history.

The SQL statement edited by the editor may be executed through the last history execution command \.



Only a single SQL statement can be edited with the SQL editor. An error occurs when executing multiple SQL statements.

The followings can be edited by using \edit.

- The most recently performed SQL statement
- the SQL statement stored in a file
- The SQL statement stored in the gsql history

The following chapter describes the usage.

## \edit

### Syntax

```
\edit  
\ed
```

### Description

It edits the most recently executed SQL statement by using the text editor. If any SQL statement has not been executed, the text editor is run without any content.

## Example

The following is an example of editing the most recently executed SQL statement.

- Editing the most recently executed SQL statement

```
gSQL> SELECT * FROM T1;
C1
--
 1
11
2 rows selected.
gSQL> \EDIT
SELECT * FROM T1 WHERE C1 < 10;
```

- Executing the edited SQL statement

```
gSQL> \\
C1
--
 1
1 row selected.
```

## `\edit 'file_name'`

### Syntax

```
\edit 'file_name'
\ed  'file_name'
```

### Description

It edits the given file\_name by using the text editor.

The file\_name is enclosed with the single quote (').

file\_name can use either an absolute path or a relative path as follows. When file\_name uses a relative path, it searches for the file\_name based on the path of gsql execution.

- Using the absolute path

```
gSQL> \edit '/home/goldilocks/sample.sql'
```

- Using the relative path

```
gSQL> \edit 'sample.sql'
```

## Example

The following is an example of editing the SQL statement stored in the file.

- Editing the most recently executed SQL statement

```
gSQL> SELECT * FROM T1;
C1
--
 1
11
2 rows selected.
gSQL> \EDIT 'sample.sql'
SELECT * FROM T1 WHERE C1 < 10;
```

- Executing the edited SQL statement

```
gSQL> \\  
C1  
--  
 1  
1 row selected.
```

## \edit [history] {n}

### Syntax

```
\edit [history] {n}  
\ed [history] {n}
```

### Description

It edits the SQL statement corresponding to the number from the SQL execution history which can be queried by using **\history**.

The value of number should be the ID value which is the result of executing **\history**.

### Example

The following is an example of editing the SQL statement stored in the gsql history.

```

gSQL> SELECT * FROM T1;
C1
--
 1
11
2 rows selected.
gSQL> \history
ID SQL
-- -----
 1 SELECT * FROM T1

```

- Editing the SQL statement whose ID value is 1 from the stored history

```

gSQL> \edit 1
SELECT * FROM T1 WHERE C1 < 5;

```

- Executing the edited SQL statement

```

gSQL> \
C1
--
 1
1 row selected.

```

## \exec

### Syntax

```
\exec
```

### Description

It executes the SQL statement which is prepared by `\prepare sql`.

\exec operates similarly to the `SQLExecute` function of ODBC and `PreparedStatement::execute` function of JDBC.

The prepared SQL statements can be repeatedly executed by using \exec.

## Examples

The following is an example of preparing an INSERT statement and repeatedly executing it.

- Preparing the INSERT statement

```
gSQL> \prepare sql INSERT INTO t1(id, addr) VALUES ( seq.NEXTVAL, 'N/A' );
SQL prepared.
```

- Executing the prepared statement

```
gSQL> \exec
1 row created.
```

- Executing the prepared statement

```
gSQL> \exec
1 row created.
```

- The results of querying the table are as follows.

```
gSQL> SELECT * FROM t1;
ID ADDR
-- ----
 1 N/A
 2 N/A
2 rows selected.
```

The following is an example of preparing the SELECT statement with the host variable and repeatedly executing it by changing the host variable value.

- Declaring the host variable

```
gSQL> \var v_id INTEGER
```

- Preparing the SELECT statement which used the host variable

```
gSQL> \prepare sql SELECT * FROM t1 WHERE ID = :v_id;
SQL prepared.
```

- Assigning the value 1 to the host variable

```
gSQL> \exec :v_id := 1
```

- Executing the prepared SELECT statement

```
gSQL> \exec
ID ADDR
-- ----
 1 N/A
1 row selected.
```

- Assigning the value 2 to the host variable

```
gSQL> \exec :v_id := 2
```

- Executing the prepared SELECT statement

```
gSQL> \exec
ID ADDR
-- ----
 2 N/A
1 row selected.
```

## **\exec :var := value**

### **Syntax**

```
\exec :variable := <value expression>
```

### **Description**

It assigns the value to the host variable.

This command assigns a value to the host variable in the same way as executing **SELECT .. INTO** as follows.

```
gSQL> \exec :v_value := 1234
gSQL> SELECT 1234 INTO :v_value FROM DUAL;
```

The host variable must have been declared with **\var**.

The host variable must be used together with colon (:), and the assignment operator (:=) is not allowed t

o omit (:). Simple values or operators may appear in <value expression> entered to the host variable. For more information, refer to **Expressions**.

The value assigned to the host variable should be compatible with the data type of the host variable. For more information, refer to **Type Conversion**.

The value assigned to the host variable may be queried by using **\print**.

```
\exec :v_value := 1234
\print v_value
```

The string should be enclosed in the single quote (') as follows when inserting the string into the host variable.

- Simple string
  - Value: abcd
  - \exec :v\_value := 'abcd'
- The string which includes the single quote
  - Value: Tom's House
  - The single quote within the string is represented with the two single quotes (') as follows.
  - \exec :v\_value := 'Tom''s House'
- The SQL statement including the single quote
  - Value: INSERT INTO t1 VALUES (1, 'Tom''s House' )
  - The single quote within the string is represented with the two single quotes (') as follows.
  - \exec :v\_value := 'INSERT INTO t1 VALUES (1, ''Tom''s House'' )'

## Examples

The following is an example of assigning the various types of string to the host variable.

- Declaring the host variable

```
gSQL> \var v_value VARCHAR(1024)
```

- Assigning the simple string

```
gSQL> \exec :v_value := 'abcd'
gSQL> \print v_value
V_VALUE
-----
abcd
```

- Assigning the string including the single quote (')

```
gSQL> \exec :v_value := 'Tom''s House'
gSQL> \print v_value
V_VALUE
-----
Tom's House
```

- Assigning the SQL statement including the single quote (')

```
gSQL> \exec :v_value := 'INSERT INTO t1 VALUES ( 1, ''Tom''s House'' )'
gSQL> \print v_value
V_VALUE
-----
INSERT INTO t1 VALUES ( 1, 'Tom's House' )
```

The following is an example of using the operation result when assigning the value to the host variable.

- Declaring the host variable

```
gSQL> \var v1 INTEGER
gSQL> \var v2 INTEGER
```

- Assigning the value to v1

```
gSQL> \exec :v1 := 100
```

- Assigning the result of operation with v1 to v2

```
gSQL> \exec :v2 := :v1 + 1000
```

- Querying the value of host variables v1 and v2

```
gSQL> \print v1
V1
---
100
gSQL> \print v2
V2
----
1100
```

The following is an example of assigning the value to the host variable and using the host variable in the SELECT statement.



- Declaring the host variable

```
gSQL> \var v_id INTEGER
```

- Assigning the value to the host variable

```
gSQL> \exec :v_id := 1
```

- Executing the SELECT statement by using the host variable

```
gSQL> SELECT * FROM t1 WHERE id = :v_id;
ID ADDR
-- ----
 1 N/A
1 row selected.
```

The following is an example of obtaining the value to the host variable via **SELECT .. INTO**.

- Declaring the host variable

```
gSQL> \var v_id INTEGER
```

- A value is not specified.

```
gSQL> \print v_id
V_ID
----
null
```

- Assigning the value to v\_id by executing the SELECT INTO statement

```
gSQL> SELECT MAX(id) INTO :v_id FROM t1;
V_ID
----
  2
1 row selected.
```

- Checking the host variable value

```
gSQL> \print v_id
V_ID
----
  2
```

## \exec sql

### Syntax

```
\exec sql <sql_statement>
```

### Description

It executes the SQL statement described in <sql\_statement>.

It operates as same as the execution of the SQL statement at the prompt as follows.

```
gSQL> SELECT * FROM dual;
DUMMY
-----
X
1 row selected.
gSQL> \exec sql SELECT * FROM dual;
DUMMY
-----
X
1 row selected.
```

The SQL statement is executed with the PREPARE/EXECUTE method using `\prepare sql` and `\exec`. On the other hand, `\exec sql` executes the SQL statement with the DIRECT EXECUTE method corresponding to `SQLExecDirect` function of ODBC and to `Statement::execute` function of JDBC.

### Example

The following is an example of executing the SELECT statement.

```
gSQL> \exec sql SELECT * FROM dual;
DUMMY
-----
X
1 row selected.
```

# \explain plan

## Syntax

```
\explain plan <sql_statement>
\explain plan on <sql_statement>
\explain plan only <sql_statement>
```

## Description

It outputs the execution plan of the SELECT statement described in <sql\_statement>.

- \explain plan on
  - It executes the SQL statement and outputs the execution plan along with the query results.
- \explain plan only
  - It does not execute the SQL statement and outputs the execution plan without the query results.
- \explain plan
  - If on or only is not specified, the default value is on.

For more information about the execution plan, refer to [SQL Execution Plan](#).

## Examples

If it is used together with ON as follows, it executes the SQL statement and outputs the execution plan with the query results.

```
gSQL> \explain plan on SELECT * FROM t1 WHERE id = 1;
ID NAME  ADDR
-- -----
 1 leekmo Seoul, Korea
1 row selected.
>>> start print plan
< Execution Plan >
=====
|  IDX  |  NODE DESCRIPTION          |  ROWS  |
-----|-----|-----|
|   0   |  SELECT STATEMENT          |         |
|   1   |  TABLE ACCESS ("T1")      |         1 |
=====
1 - READ COLUMNS : ID, NAME, ADDR
```

```

                PHYSICAL FILTER : ID = 1
<<< end print plan

```

If it is used together with ONLY as follows, it does not execute the SQL statement and outputs the execution plan without the query results.

```

gSQL> \explain plan only SELECT * FROM t1 WHERE id = 1;
>>> start print plan
< Execution Plan >
=====
|  IDX  |  NODE DESCRIPTION          |  ROWS  |
-----|-----|-----|
|   0   |  SELECT STATEMENT          |         |
|   1   |  TABLE ACCESS ("T1")      |        0 |
=====
      1 - READ COLUMNS : ID, NAME, ADDR
          PHYSICAL FILTER : ID = 1
<<< end print plan

```

## \help

### Syntax

```
\help
```

### Description

It briefly displays the list of commands which begin with (\) in gsql interactive mode.

### Examples

The following is an example of using \help.

```

gSQL> \help
\help
\q[uit]
\i[mport] {'FILE'}          Import SQL
\ed[it] [{'FILE'}[HISTORY] num]} Edit SQL statement
\\                          Executes the most recent history entry

```

```

\{n}                               Executes n'th history entry
\hi[story]                          Show history entries
\desc    {[schema.]table_name}     Show table description
\idesc   {[schema.]index_name}     Show index description
\spo[ol] ['filename' | OFF]        Stores query results in a file
\ho[st]  [command]                 Executes an operating system command
\set vertical    {ON|OFF}
\set time        {ON|OFF}
\set timing      {ON|OFF}
\set color       {ON|OFF}
\set error       {ON|OFF}
\set autocommit  {ON|OFF}
\set autotrace   {ON|TRACEONLY|OFF}
\set serveroutput {ON|OFF}
\set heading     {ON|OFF}
\set linesize   {n}      0 < n <= 100000
\set pagesize    {n}      0 < n <= 100000
\set colsize     {n}      0 < n <= 104857600
\set numsize     {n}      0 < n <= 50
\set ddlsize     {n}      0 < n <= 100000
\set history     {n}      n <= 100000 ( if n < 0, clear history buffer )
\var            {host_var_name} {INTEGER|BIGINT|VARCHAR(n)}
\exec           [[:host_var_name] := {constant}]
\exec sql      {sql string}
\prepare sql    {sql string}
\dynamic sql    {host_var_name}
\explain plan   [{ON|ONLY}] {sql string}
\print         [{host_var_name}]
\ddl_db
\ddl_tablespace {name}
\ddl_auth       {name}
\ddl_schema     {name}
\ddl_table      {[schema.]name}
\ddl_constraint {[schema.]name}
\ddl_index      {[schema.]name}
\ddl_view       {[schema.]name}
\ddl_sequence   {[schema.]name}
\ddl_synonym     {[schema.]name}
\ddl_public_synonym {name}
\startup        {[nomount|mount|open]}
\shutdown       {[abort|immediate|transactional|normal]}

```

```
\cstartup      {[nomount|mount|open]}
\cshutdown     {[abort|normal]}
\connect       [userid password] [as {sysdba|admin}]
```

## \host

### Syntax

```
\host [command]
\ho [command]
```

### Description

It executes the command of the operational system without terminating gsql program.

If HOST is input without command, then the prompt of the operational system is displayed and it is able to continuously input the command of the operational system.

Instead of HOST, "\$" is input in Windows, and "!" is input in UNIX.

### Example

The following is an example of executing ls \*.sql statement which is a command of UNIX operational system.

```
gSQL> \host ls *.sql
DictionarySchema.sql  InformationSchema.sql  PerformanceViewSchema.sql
```

## \history

### Syntax

```
\history
\hi
```

## Description

It displays the list of the SQL statements executed after executing gsql program.

It manages only the successfully executed SQL statements and it does not include the failed SQL statements nor the interactive command which begins with gsql(\).

The previously executed SQL statements can be executed again referring to the list through \ or \{n}.

The number of manageable SQL statements is controlled by using `\set history`.

## Example

The following is an example of querying the SQL statement execution history and executing the SQL statement of number 8 again.

```
gSQL> \history
ID SQL
-----
1 drop table t1
2 create table t1 ( id integer, name varchar(128), addr varchar(1024) )
3 create index t1_idx on t1(id)
4 insert into t1 values ( 1, 'leekmo', 'Seoul, Korea' )
5 insert into t1 values ( 2, 'mkkim', 'Seoul, Korea' )
6 insert into t1 values ( 3, 'xcom73', 'Inchon, Korea' )
7 commit
8 select * from dual
gSQL> \8
DUMMY
-----
X
1 row selected.
```

## \import

### Syntax

```
\import 'file_name'
\i 'file_name'
```

## Description

It imports the SQL statement included in file\_name.

The file\_name is enclosed with the single quote (').

file\_name can use either an absolute path or a relative path as follows. When file\_name uses a relative path, it searches for the file\_name based on the path of gsql execution.

- Using the absolute path

```
gSQL> \import '/home/GOLDILOCKS/sample.sql'
```

- Using the relative path

```
gSQL> \import 'sample.sql'
```

## Examples

The following is an example of importing the SQL statement from the file by using the absolute path.

```
gSQL> \import '/home/GOLDILOCKS/sample.sql'
DROP TABLE IF EXISTS t1;
Table dropped.
CREATE TABLE t1
(
  id  INTEGER,
  name VARCHAR(128),
  addr VARCHAR(128)
);
Table created.
INSERT INTO t1
  VALUES ( 1, 'leekmo', 'Seoul, Korea' ),
         ( 2, 'mkkim' , 'Seoul, Korea' ),
         ( 3, 'xcom73', 'Inchon, Korea' );
3 rows created.
COMMIT;
Commit complete.
```

The following is an example of importing the SQL statement from the file by using the relative path.

```
gSQL> \import 'sample.sql'
DROP TABLE IF EXISTS t1;
Table dropped.
```



```
CREATE TABLE t1
(
  id    INTEGER,
  name  VARCHAR(128),
  addr  VARCHAR(128)
);
Table created.
INSERT INTO t1
VALUES ( 1, 'leekmo', 'Seoul, Korea' ),
       ( 2, 'mkkim' , 'Seoul, Korea' ),
       ( 3, 'xcom73', 'Inchon, Korea' );
3 rows created.
COMMIT;
Commit complete.
```

## \idesc

### Syntax

```
\idesc index_name
\idesc schema_name.index_name
```

### Description

It queries the structure information of the index.

An index can be described alone as follows or it can be described together with the schema name. If the schema name is not specified, the schema name of the index is determined by the user's **Schema Path**.

- \idesc t1\_idx\_name
- \idesc public.t1\_idx\_name

The execution result includes the following key column information of the index.

- Key column name
- Key column location
- Key column sort order (ascending/ descending)
- NULL position of the key column(FIRST/ LAST)

## Example

The following is an example of querying the information of the index t1\_idx\_name.

```
gSQL> \idesc t1_idx_name
COLUMN_NAME  ORDINAL_POSITION  IS_ASCENDING_ORDER  IS_NULLS_FIRST
-----
NAME                1  TRUE                FALSE
```

`\{n}`

## Syntax

```
\number
```

## Description

It executes the SQL statement corresponding to the number from the SQL execution history which can be queried by using `\history`.

The value of number should be the ID value which is the result of executing `\history`.

## Examples

The following is an example of executing SQL statement which used `\history`, then executing the DROP TABLE statement whose ID value is 1.

```
gSQL> \history
ID SQL
-----
1 DROP TABLE IF EXISTS t1
2 CREATE TABLE t1
  (
    id  INTEGER PRIMARY KEY,
    name VARCHAR(128),
    addr VARCHAR(128)
  )
3 CREATE INDEX t1_idx_name ON t1(name)
4 INSERT INTO t1
  VALUES ( 1, 'leekmo', 'Seoul, Korea' ),
```

```

        ( 2, 'mkkim' , 'Seoul, Korea' ),
        ( 3, 'xcom73', 'Inchon, Korea' )
5 COMMIT
6 select * from t1
gSQL> \1
Table dropped.

```

## \prepare sql

### Syntax

```
\prepare sql <sql_statement>
```

### Description

It prepares the SQL statement described in <sql\_statement>. The prepared SQL statement can be executed repeatedly with **\exec**.

**\prepare sql** operates similarly to the **SQLPrepare** functions of ODBC and **Connection::prepareStatement** function of JDBC.

### Example

The following is an example of preparing the SELECT statement and repeatedly executing it.

- Preparing the SELECT statement

```

gSQL> \prepare sql SELECT * FROM t1 WHERE id > 2;
SQL prepared.

```

- Executing the prepared SQL statement

```

gSQL> \exec
ID NAME  ADDR
-----
3 xcom73 Inchon, Korea
1 row selected.
gSQL> INSERT INTO t1 VALUES ( 4, 'GOLDILOCKS', 'Better Place' );
1 row created.

```

- Executing the prepared SQL statement again

```
gSQL> \exec
ID NAME      ADDR
-----
3 xcom73 Inchon, Korea
4 goldilocks Better Place
2 rows selected.
```

## \print

### Syntax

```
\print
\print variable
```

### Description

It queries the value of host variable declared with **\var** as follows. If the value of host variable is not set, it is NULL.

```
gSQL> \var v1 INTEGER
gSQL> \print v1
  V1
----
null
```

If the name of host variable is not specified as follows, it queries all declared host variables. VAR\_ELAPSED\_TIME\_\_ is a built-in host variable which manages the execution time of SQL statement as follows.

```
gSQL> \print
NAME                VALUE
-----
VAR_ELAPSED_TIME__ null
V1                   21
V2                   10
```

## Example

The following is an example of declaring the host variable, assigning the value to the host variable then querying it.

- Declaring the host variable

```
gSQL> \var v1 INTEGER
gSQL> \var v2 INTEGER
gSQL> \var v3 INTEGER
```

- Querying all host variables

```
gSQL> \print
NAME                VALUE
-----
VAR_ELAPSED_TIME__ null
V1                   null
V2                   null
V3                   null
```

- Assigning the value to the host variable

```
gSQL> \exec :v1 := 10
gSQL> \exec :v2 := 20
gSQL> \exec :v3 := :v1 + :v2
```

- Querying the host variable v3

```
gSQL> \print v3
V3
--
30
```

- Querying all host variables

```
gSQL> \print
NAME                VALUE
-----
VAR_ELAPSED_TIME__ null
V1                   10
V2                   20
V3                   30
```

## `\quit`

### Syntax

```
\quit  
\q
```

### Description

It quits gsql.

When quitting gsql, all uncommitted transactions are committed.

### Example

```
gSQL> \quit  
%
```

## `\set autocommit`

### Syntax

```
\set autocommit on  
\set autocommit off
```

### Description

It sets whether to automatically commit after executing the SQL statement.

- `\set autocommit on`
  - It automatically commits after executing the SQL statement.
- `\set autocommit off`
  - It does not automatically commit after executing the SQL statement.
- The default value of autocommit is OFF.

## Examples

The following is a usage example when setting the AUTOCOMMIT value to ON.

- Setting the autocommit to on

```
gSQL> \set autocommit on
```

- The INSERT statement is automatically committed.

```
gSQL> INSERT INTO t1 ( id, name, addr ) VALUES ( 1, 'leekmo', 'Seoul, Korea' );
1 row created.
```

- It is not affected by rollback.

```
gSQL> ROLLBACK;
Rollback complete.
gSQL> SELECT * FROM t1;
ID NAME  ADDR
-- -----
 1 leekmo Seoul, Korea
1 row selected.
```

The following is a usage example when setting the AUTOCOMMIT value to OFF.

- Setting the autocommit to off

```
gSQL> \set autocommit off
```

- The transaction is not committed after executing the INSERT statement.

```
gSQL> INSERT INTO t1 ( id, name, addr ) VALUES ( 1, 'leekmo', 'Seoul, Korea' );
1 row created.
```

- The transaction is rolled back.

```
gSQL> ROLLBACK;
Rollback complete.
```

- The INSERT statement is rolled back without any result.

```
gSQL> SELECT * FROM t1;
no rows selected.
```

## \set autotrace

### Syntax

```
\set autotrace on
\set autotrace traceonly
\set autotrace off
```

### Description

It sets whether to output the execution plan.

- \set autotrace on
  - It executes SQL statement, and outputs the execution plan together with the query result.
- \set autotrace traceonly
  - It does not execute SQL statement, and outputs the execution plan without the query result.
- \set autotrace off
  - It does not output the execution plan.
  - The default value is off.

For more information, refer to [SQL execution plan](#).

### Example

When using ON as follows, it executes SQL statement and outputs the execution plan together with the query result.

```
gSQL> \set autotrace on
gSQL> SELECT * FROM t1 WHERE id = 1;
ID NAME  ADDR
-----
1 leekmo Seoul, Korea
1 row selected.
>>> start print plan
< Execution Plan >
=====
|  IDX  |  NODE DESCRIPTION          |  ROWS  |
-----|-----|-----|
|    0  |  SELECT STATEMENT          |         |
|    1  |  TABLE ACCESS ("T1")     |        1 |
```



```
=====
1 - READ COLUMNS : ID, NAME, ADDR
    PHYSICAL FILTER : ID = 1
<<< end print plan
```

When using TRACEONLY as follows, it does not execute SQL statement, and outputs the execution plan without the query result.

```
gSQL> \set autotrace traceonly
gSQL> SELECT * FROM t1 WHERE id = 1;
>>> start print plan
< Execution Plan >
=====
|  IDX  |  NODE DESCRIPTION          |  ROWS  |
-----|-----|-----|
|   0   |  SELECT STATEMENT          |         |
|   1   |  TABLE ACCESS ("T1")     |        0 |
=====

1 - READ COLUMNS : ID, NAME, ADDR
    PHYSICAL FILTER : ID = 1
<<< end print plan
```

## \set color

### Syntax

```
\set color on
\set color off
```

### Description

It sets whether to output each row of the query results in a different color on the terminal to distinguish them.

- \set color on
  - Each row is output in a different color.
- \set color off
  - Each row is output in the same color.
- The default value is OFF.

If the length of each row is too long so that it overflows the terminal window, then the row is output over multiple lines. In this case, each row is hard to be distinguished, so it reduces the readability. It is used to distinguish between the rows and increase the readability on the terminal.

## Example

The following is an example of setting the color to ON.

```
gSQL> \set color on
gSQL> SELECT id, addr FROM t1;
ID ADDR
-- -----
1 Seoul, Korea
2 Seoul, Korea
3 Incheon, Korea
3 rows selected.
```

## \set colsize

### Syntax

```
\set colsize number
```

### Description

It sets the maximum length of the data when outputting LONG VARCHAR, LONG VARBINARY data.

- The colsize value is a positive integer between 1 and 104,857,600.(100M, the maximum length of LONG VARCHAR)
- The default value of colsize is 8,192.

The string length of the LONG VARCHAR column is too long, so the readability of the query execution is low as follows. In this case, the readability of LONG VARCHAR column can be increased by reducing the colsize, or it may be output as long as the desired length by enlarging the colsize.

```
gSQL> SELECT view_name, text FROM all_views WHERE view_name LIKE 'ALL_%' FETCH 3;
VIEW_NAME
-----
TEXT
-----
```

```

ALL_ALL_TABLES
SELECT
    auth.AUTHORIZATION_NAME          ❶ OWNER
    , sch.SCHEMA_NAME                ❷ TABLE_SCHEMA
    ... Ellipsis ...
    WHERE
    , pvcol.GRANTEE_ID
    , pvcol.PRIVILEGE_TYPE_ID

3 rows selected.

```

## Example

The following is an example of increasing the readability of the LONG VARCHAR column by reducing the colsize.

```

gSQL> \set colsize 200
gSQL> SELECT view_name, text FROM all_views WHERE view_name LIKE 'ALL_%' FETCH 3;
VIEW_NAME      TEXT
-----
ALL_ALL_TABLES  SELECT
                auth.AUTHORIZATION_NAME          ❶ OWNER
                , sch.SCHEMA_NAME                ❷ TABLE_SCHEMA
                , tab.TABLE_NAME                 ❸ TABLE_NAME
                , spc.TAB
ALL_COL_COMMENTS SELECT
                auth.AUTHORIZATION_NAME
                , sch.SCHEMA_NAME
                , tab.TABLE_NAME
                , col.COLUMN_NAME
                , col.COMMENTS
                FROM
                DICTIONARY_SCHEMA.WHOLE_COLUMNS AS col
                , DICTIONARY_S
ALL_COL_PRIVS   SELECT
                grantor.AUTHORIZATION_NAME
                , grantee.AUTHORIZATION_NAME
                , owner.AUTHORIZATION_NAME
                , sch.SCHEMA_NAME
                , tab.TABLE_NAME

```

```
, col.COLUMN_NAME
, pvcol.PRIVILEGE_TY
```

3 rows selected.

## \set ddlsize

### Syntax

```
\set ddlsize number
```

### Description

It sets the buffer size to output the statement when outputting the DDL statements by using the following commands.

- \ddl\_db
  - \ddl\_tablespace
  - \ddl\_auth
  - \ddl\_schema
  - \ddl\_table
  - \ddl\_constraint
  - \ddl\_index
  - \ddl\_view
  - \ddl\_sequence
  - \ddl\_synonym
  - \ddl\_public\_synonym
  - \ddl\_procedure
  - \ddl\_package
- The value of ddlsize is a positive integer between 1 and 1,0485,760 (10M).
  - The default value of ddlsize is 10,000.

If an error occurs due to the lack of buffer space as follows, DDL statement may be output by increasing the value of ddlsize.

```
gSQL> \set ddlsize 1000
gSQL> \ddl_view dictionary_schema.all_tables
ERR-HY000(40052): not enough DDLSIZE.
use command: \set ddlsize {n}
gSQL> \set ddlsize 100000
```

```
gSQL> \ddl_view dictionary_schema.all_tables
SET SESSION AUTHORIZATION "SYS";
CREATE OR REPLACE FORCE VIEW "DICTIONARY_SCHEMA"."ALL_TABLES"
... Ellipsis ...
```

## Example

The following is an example of changing the ddlsize.

```
gSQL> \set ddlsize 100000
gSQL>
```

## \set error

### Syntax

```
\set error on
\set error off
```

### Description

It sets whether to output the error message.

- \set error on
  - It outputs the error message.
- \set error off
  - It does not output the error message.
- The default value of error is ON.

If an error occurs during executing the SQL statement, gsql outputs the following information.

- SQLSTATE: SQL standard state code
- Error code: GOLDILOCKS error code
- Error message

The following example describes that the error of the SQL statement occurs, the SQLSTATE value in ERR-42000(16040) is 42000, and the error code is 16040 within ().

```
gSQL> SELECT * FROM invalid_table;
ERR-42000(16040): table or view does not exist :
SELECT * FROM invalid_table
          *
ERROR at line 1:
```

## Example

The following is an example of disabling the error message.

- Disabling the error message

```
gSQL> \set error off
```

- Outputting only the value of SQLSTATE and the error code

```
gSQL> SELECT * FROM invalid_table;
ERR-42000(16040)
```

## \set heading

### Syntax

```
\set heading {ON|OFF}
```

### Description

It sets whether to output the header in the query result.

### Example

- Set not to output the header message.

```
gSQL> \set heading off
```

- The following is an example of a query result in which the header message is not output.

```
gSQL> select * from dual;
X
```

1 row selected.

## \set history

### Syntax

```
\set history number
```

### Description

It sets the number of SQL statements to manage the history information.

- The history value is a positive integer between 1 and 100,000.
- If the history value is set to a negative value, all SQL history are removed.
- The default value of history is 128.

If the history value is reduced, the old SQL statement is removed.

The history information is used when executing the previously executed SQL statement again through `\` and `{n}`.

### Example

The following is an example of setting the number of history to 100.

```
gSQL> \set history 100
gSQL>
```

The following is an example of setting the number of history to smaller than the number of stored SQL statements.

- Five SQL statements are stored.

```
gSQL> \history
ID SQL
-----
1 DROP TABLE IF EXISTS t1
2 CREATE TABLE t1
  (
    id INTEGER PRIMARY KEY,
    name VARCHAR(128),
```

```

        addr VARCHAR(128)
    )
3 CREATE INDEX t1_idx_name ON t1(name)
4 INSERT INTO t1
    VALUES ( 1, 'leekmo', 'Seoul, Korea' ),
           ( 2, 'mkkim' , 'Seoul, Korea' ),
           ( 3, 'xcom73', 'Inchon, Korea' )
5 COMMIT

```

- The history value is reduced to 3.

```
gSQL> \set history 3
```

- Three SQL statements are stored.

```

gSQL> \history
ID SQL
-----
3 CREATE INDEX t1_idx_name ON t1(name)
4 INSERT INTO t1
    VALUES ( 1, 'leekmo', 'Seoul, Korea' ),
           ( 2, 'mkkim' , 'Seoul, Korea' ),
           ( 3, 'xcom73', 'Inchon, Korea' )
5 COMMIT

```

The following is an example of removing all SQL statements stored in the history.

```

gSQL> \history
ID SQL
-----
1 SELECT * FROM dual
2 SELECT * FROM user_tables

```

- All SQL history are removed by using a negative value.

```

gSQL> \set history -1
gSQL> \history
gSQL>

```



# \set linesize

## Syntax

```
\set linesize number
```

## Description

It sets the maximum size of a single line when outputting the query result.

- The value of linesize is a positive integer between 1 and 10,000.
- The default value of linesize is 80.

Each row of the query result is output on a single line basis. If there are many columns in a row or the row length is bigger than linesize, a row is output to the multiple lines so the readability is decreased.

```
gSQL> SELECT * FROM dict_columns WHERE table_name = 'USER_TABLES' FETCH 3;
TABLE_SCHEMA      TABLE_NAME  COLUMN_NAME
-----
COMMENTS
-----
DICTIONARY_SCHEMA USER_TABLES TABLE_SCHEMA
Schema of the table
DICTIONARY_SCHEMA USER_TABLES TABLE_NAME
Name of the table
DICTIONARY_SCHEMA USER_TABLES TABLESPACE_NAME
Name of the tablespace containing the table
3 rows selected.
```

In this case, a row may be controlled to be output in a single line by changing the linesize value.

## Example

The following is an example of increasing the readability by setting the linesize larger.

```
gSQL> \set linesize 400
gSQL> SELECT * FROM dict_columns WHERE table_name = 'USER_TABLES' FETCH 3;
TABLE_SCHEMA      TABLE_NAME  COLUMN_NAME      COMMENTS
-----
DICTIONARY_SCHEMA USER_TABLES TABLE_SCHEMA    Schema of the table
```

```

DICTIONARY_SCHEMA USER_TABLES TABLE_NAME      Name of the table
DICTIONARY_SCHEMA USER_TABLES TABLESPACE_NAME Name of the tablespace containing the table
3 rows selected.

```

## \set numsize

### Syntax

```
\set numsize number
```

### Description

It sets the maximum number of digit for the output of a numeric value.

- The numsize value is a positive integer between 1 and 50.
- The default value of numsize is 20.

If the number of digit of a numeric value exceeds the numsize range as follows, it is output in an exponential form.

```

gSQL> SELECT num, ( num * num ) AS result FROM t1;
          NUM              RESULT
-----
1234567890123 1.52415787532276E+24
1 row selected.

```

By changing the value of numsize, these numeric value is output in a numeric form, not in an exponential form.

### Example

The following is an example of outputting all digits of the numeric value by setting the numsize larger.

```

gSQL> \set numsize 50
gSQL> SELECT num, ( num * num ) AS result FROM t1;
          NUM              RESULT
-----
1234567890123 1524157875322755800955129
1 row selected.

```

# \set pagesize

## Syntax

```
\set pagesize number
```

## Description

It sets the number of the rows which is to be consisted in a single page.

- The value of pagesize is a positive integer between 1 and 10,000.
- The default value of pagesize is 20.

It is set when there are many rows of the query results or when a page should consist of a certain number of row.

## Example

The following is an example of consisting a page in 10 rows unit.

```
gSQL> \set linesize 120
gSQL> \set pagesize 10
gSQL> SELECT column_name, comments FROM dict_columns WHERE table_name = 'SEQUENCES';
COLUMN_NAME      COMMENTS
-----
OWNER_ID          authorization identifier who owns the table of the sequence generator
SCHEMA_ID         schema identifier of the sequence generator
SEQUENCE_ID       sequence generator identifier
SEQUENCE_TABLE_ID table id of sequence for naming resolution
TABLESPACE_ID     tablespace identifier of the sequence generator
PHYSICAL_ID       physical identifier of the sequence generator
SEQUENCE_NAME     sequence generator name
DTD_IDENTIFIER    unsupported feature
START_VALUE       the start value of the sequence generator
MINIMUM_VALUE     the minimum value of the sequence generator
COLUMN_NAME      COMMENTS
-----
MAXIMUM_VALUE     the maximum value of the sequence generator
INCREMENT         the increment of the sequence generator
CYCLE_OPTION      The values of CYCLE_OPTION have the following meanings:
```

- TRUE : The cycle option of the sequence generator is CYCLE.
- FALSE : The cycle option of the sequence generator is NO CYCLE.

```

CACHE_SIZE          number of sequence numbers to cache
CREATED_TIME        created time of the sequence generator
MODIFIED_TIME       last modified time of the sequence generator
COMMENTS            comments of the sequence generator
SEQUENCE_CATALOG    catalog name of the sequence
SEQUENCE_OWNER      owner name of the sequence
SEQUENCE_SCHEMA     schema name of the sequence
COLUMN_NAME         COMMENTS
-----
SEQUENCE_NAME       sequence name
DATA_TYPE           the standard name of the data type
NUMERIC_PRECISION   the numeric precision of the numerical data type
NUMERIC_PRECISION_RADIX the radix ( 2 or 10 ) of the precision of the numerical data type
NUMERIC_SCALE       the numeric scale of the exact numerical data type
START_VALUE         the start value of the sequence generator
MINIMUM_VALUE       the minimum value of the sequence generator
MAXIMUM_VALUE       the maximum value of the sequence generator
INCREMENT           the increment of the sequence generator
CYCLE_OPTION        cycle option
COLUMN_NAME         COMMENTS
-----
CACHE_SIZE          number of sequence numbers to cache
DECLARED_DATA_TYPE  the data type name that a user declared
DECLARED_NUMERIC_PRECISION the precision value that a user declared
DECLARED_NUMERIC_SCALE the scale value that a user declared
CREATED_TIME        created time of the sequence generator
MODIFIED_TIME       last modified time of the sequence generator
COMMENTS            comments of the sequence generator
37 rows selected.

```

## \set serveroutput

### Syntax

```

\set serveroutput on
\set serveroutput off

```

## Description

It controls automatic output feature for the message writeten by functions of which DBMS\_OUTPUT pack age provides in gsql or gsqlnet

- \set serveroutput on
  - It automatically outputs messages accumulated in the server by DBMS\_OUTPUT.PUT\_LINE after e xecuting SQL.
- \set serveroutput off
  - It does not use DBMS\_OUTPUT package.
- The default value of serveroutput is OFF.

Basically, the maximum size of accumulated in the server is 20000 bytes.

## Example

The following is an example of outputting the messages accumulated in a user defined function which w as used in SQL statement.

```
gSQL> create or replace function my_msg( msg varchar(100) )
return integer
is
begin
  dbms_output.put_line( 'my message is : ' || msg );
  return length( msg );
end;
/
2 3 4 5 6 7 8
Function created.
gSQL> commit;
Commit complete.
gSQL> \set serveroutput on
gSQL> select my_msg( 'Hello World!' ) from dual;
MY_MSG( 'Hello World!' )
-----
                               12
my message is : Hello World!
1 row selected.
```

## `\set time`

### Syntax

```
\set time on  
\set time off
```

### Description

It sets whether to output the current time.

- `\set time on`
  - It outputs the current time.
- `\set time off`
  - It does not output the current time.
- The default value of time is OFF.

### Example

The following is an example of outputting the current time.

```
gSQL> \set time on  
12:45:34 gSQL> SELECT * FROM dual;  
DUMMY  
-----  
X  
1 row selected.  
Elapsed time: 0.07600 ms
```

## `\set timing`

### Syntax

```
\set timing on  
\set timing off
```

## Description

It sets whether to output the execution time of SQL statement.

- `\set timing on`
  - The execution time is output.
- `\set timing off`
  - The execution time is not output.
- The default value of timing is OFF.

The unit of execution time is ms (millisecond).

## Example

The following is an example of outputting the execution time of SQL statement.

```
gSQL> \set timing on
gSQL> SELECT * FROM dual;
DUMMY
-----
X
1 row selected.
Elapsed time: 0.07600 ms
```

## `\set vertical`

### Syntax

```
\set vertical on
\set vertical off
```

## Description

It sets whether to output the value of column in line unit.

- `\set vertical on`
  - A column is output in a line unit.
- `\set vertical off`
  - A row is output in a line unit.
- The default value of vertical is OFF.

If each row has an individual information, the readability can be increased by outputting the query result in a column unit.

If `\set vertical on` is set, then each row is separated by a blank line, and one line represents a single value, then it is consisted in the following form.

```
column name # data value
```

## Example

The following is an example of outputting a query result in a column unit.

```
gSQL> \set vertical on
gSQL> SELECT * FROM v$system_stat FETCH 10;
      STAT_NAME # SYSTEM_SAR
      STAT_VALUE # 3
      COMMENTS # system available resource( 0:none, 1:session 2:database )
      STAT_NAME # MAX_ENVIRONMENT_COUNT
      STAT_VALUE # 128
      COMMENTS # maximum environment count
      STAT_NAME # FREE_ENVIRONMENT_ID
      STAT_VALUE # 81
      COMMENTS # available environment identifier
      STAT_NAME # MAX_SESSION_COUNT
      STAT_VALUE # 128
      COMMENTS # maximum session count
      STAT_NAME # FREE_SESSION_ID
      STAT_VALUE # 82
      COMMENTS # available session identifier
      STAT_NAME # MAX_PROCESS_COUNT
      STAT_VALUE # 128
      COMMENTS # maximum process count
      STAT_NAME # FREE_PROCESS_ID
      STAT_VALUE # 1
      COMMENTS # available process identifier
      STAT_NAME # CACHE_ALIGNED_SIZE
      STAT_VALUE # 64
      COMMENTS # cache aligned size
      STAT_NAME # CPU_COUNT
      STAT_VALUE # 8
      COMMENTS # count of CPUs
      STAT_NAME # SYSTEM_TIME
```



```
STAT_VALUE # 1408676900172925
```

```
COMMENTS # system time
```

```
10 rows selected.
```

## \shutdown

### Syntax

```
\shutdown
```

```
\shutdown abort
```

```
\shutdown immediate
```

```
\shutdown transactional
```

```
\shutdown normal
```

### Description

It shuts down the GOLDILOCKS server.

It should be connected as SYSDBA or ADMIN role to perform \shutdown. For more information about connecting as SYSDBA, refer to **Startup and Shutdown Server**.

- \shutdown normal
  - It blocks the connection from the new session and waits for all currently connected sessions to be terminated, then performs the checkpoint and shuts down the server.
- \shutdown transactional
  - It blocks the start of a new transaction and waits for all currently running transactions to be terminated, then performs the checkpoint and shuts down the server.
- \shutdown immediate
  - It blocks the execution of a new unit operation(ex FETCH or EXECUTE, etc.), waits for all currently running unit operations to be terminated, then rolls back all transactions and performs the checkpoint and shuts down the server.
- \shutdown abort
  - The server is forcibly shut down immediately regardless of the status of the currently connected session.
- \shutdown
  - It is as same as \shutdown normal.

## Example

The following is an example of shutting down GOLDILOCKS.

```
% gsql --as sysdba
Connected to GOLDILOCKS Database.
gSQL> \shutdown
Shutdown success
gSQL>
```

## \spool

### Description

It sets all results output by using gsql to be stored in the terminal and file.

### \spool 'filename'

#### Syntax

```
\spool 'filename' [CREATE | REPLACE | APPEND]
\spo  'filename' [CREATE | REPLACE | APPEND]
```

### Description

It starts the spool function. All output results performed by gsql are stored in the given filename since executing this statement.

The following options describe how to open the file.

- CREATE: It creates the file. If a file already exists, an error occurs.
- REPLACE: It removes the contents of an existing file, and newly starts storing. If a file does not exist, it performs as same as CREATE.
- APPEND: It continues to store the contents from the end of an existing file. If a file does not exist, it performs as same as CREATE.

If these options are not given, it is operated in REPLACE mode by default.



When starting a new spool during spooling, the existing spool stops and a new spool starts.

## Example

The following is an example of starting spooling.

- Creating the result.txt file and storing the gsql execution result

```
gSQL> \SPPOOL 'result.txt' CREATE
gSQL> SELECT * FROM T1 WHERE C1 < 10;
gSQL> \SPPOOL OFF
```

- Continuing to store the result at the end of the existing result.txt file

```
gSQL> \SPPOOL 'result.txt' APPEND
gSQL> SELECT * FROM T1 WHERE C1 >= 10;
gSQL> \SPPOOL OFF
```

- Removing the contents of the existing result.txt file and storing a new result

```
gSQL> \SPPOOL 'result.txt' REPLACE
gSQL> SELECT * FROM T1;
gSQL> \SPPOOL OFF
```

## \spool OFF

### Syntax

```
\spool OFF
\spo  OFF
```

### Description

It ends the current spool. If the spool is not in use, it does not perform any transaction.

### Example

The following is an example of starting the spool then ending it.

```
gSQL> \SPPOOL 'result.txt'
gSQL> SELECT * FROM T1;
```

- Ending spooling

```
gSQL> \SP00L OFF
```

## \spool

### Syntax

```
\spool  
\spo
```

### Description

It represents the current spool state. If the spool is in use, it informs which file is spooling. Otherwise, it informs that the spool is not in use.

### Example

The following is an example of editing the SQL statement stored in the gsql history.

```
gSQL> \SP00L 'a.txt'
```

- It informs that it is spooling in a.txt.

```
gSQL> \SP00L
```

```
currently spooling to a.txt
```

```
gSQL> \SP00L OFF
```

- It informs that it is not spooling.

```
gSQL> \SP00L
```

```
not spooling currently
```

## \startup

### Syntax

```
\startup  
\startup nomount
```

```
\startup mount
```

```
\startup open
```

## Description

It starts up the GOLDILOCKS server.

It should be connected as SYSDBA or ADMIN role to perform \startup.

For more information about connecting as SYSDBA, refer to **Startup and Shutdown Server**.

- \startup nomount
  - It starts up the server on the NOMOUNT phase.
- \startup mount
  - It starts up the server on the MOUNT phase.
- \startup open
  - It starts up the server on the OPEN phase.
- \startup
  - It is as same as \startup open.

The server start up is divided into NOMOUNT, MOUNT, OPEN phase. For more information, refer to **Multi-level Startup**.

Execute **ALTER SYSTEM {MOUNT | OPEN} DATABASE** statement to move on to the next phase after executing \startup.

## Example

The following is an example of starting up GOLDILOCKS.

```
% gsql --as SYSDBA
Connected to an idle instance.
gSQL> \startup
Startup success
```

## \var

## Syntax

```
\var variable_name data_type
```

## Description

It declares the host variable.

When declaring the host variable which is as same as `variable_name`, the existing host variable is removed and a new one is declared. The maximum length of `variable_name` is 128 bytes.

The `data_type` of host variable is as same as the data type of GOLDILOCKS.

For more information, refer to **Data Type**.

The host variable assigns the value by using `\exec :var := value`, and its value is queried by using `\print`.

```
gSQL> \var v1 INTEGER
gSQL> \exec :v1 := 1
gSQL> \print v1
V1
--
1
```

The host variable can be used as an input or output parameter in the SQL statement. When the host variable is used in the SQL statement or `\exec :var := value`, a colon (:) sign should be put in front of the host variable to indicate that it is a host variable.

## Example

The following is an example of declaring the host variable and using it as an input argument of the SQL statement.

```
gSQL> \var v1 INTEGER
gSQL> \exec :v1 := 1
gSQL> SELECT * FROM t1 WHERE id = :v1;
ID NAME    ADDR
--
1 leekmo Seoul, Korea
1 row selected.
```

The following is an example of using the host variable as an output argument of the SQL statement.

```
gSQL> \var v_name VARCHAR(128)
gSQL> SELECT name INTO :v_name FROM t1 WHERE id = 1;
V_NAME
-----
leekmo
1 row selected.
```

The following is an example of declaring the host variable and using it as the input and output arguments of the SQL statement.

In the following **UPDATE name RETURNING .. INTO** statement, the host variable of SET clause and WHERE clause, `:v_id`, is used as an input argument and `:v_id` of INTO clause is used as an output argument.

```
gSQL> \var v_name VARCHAR(128)
gSQL> \var v_id INTEGER
gSQL> \exec :v_id := 1
gSQL> UPDATE t1 SET id = 100 + :v_id WHERE id = :v_id RETURNING id INTO :v_id;
V_ID
----
 101
1 row updated.
gSQL> \print v_id
V_ID
----
 101
```





**40.**

---

**gloader/gloadernet(Upload/download Tool)**

## 40.1 Overview of gloder and gloadernet

gloder is a utility which downloads or uploads data of GOLDILOCKS in table unit.

**Table 40-1** Execution files

Name	Description
gloder	It is used in Direct Attach (D/A) environment.
gloadernet	It is used in Client/ Server (C/S) environment.

### Environment

gloder should be connected to the database and it requires attention to all required files while using gloder.

**Figure 1** gloder environment

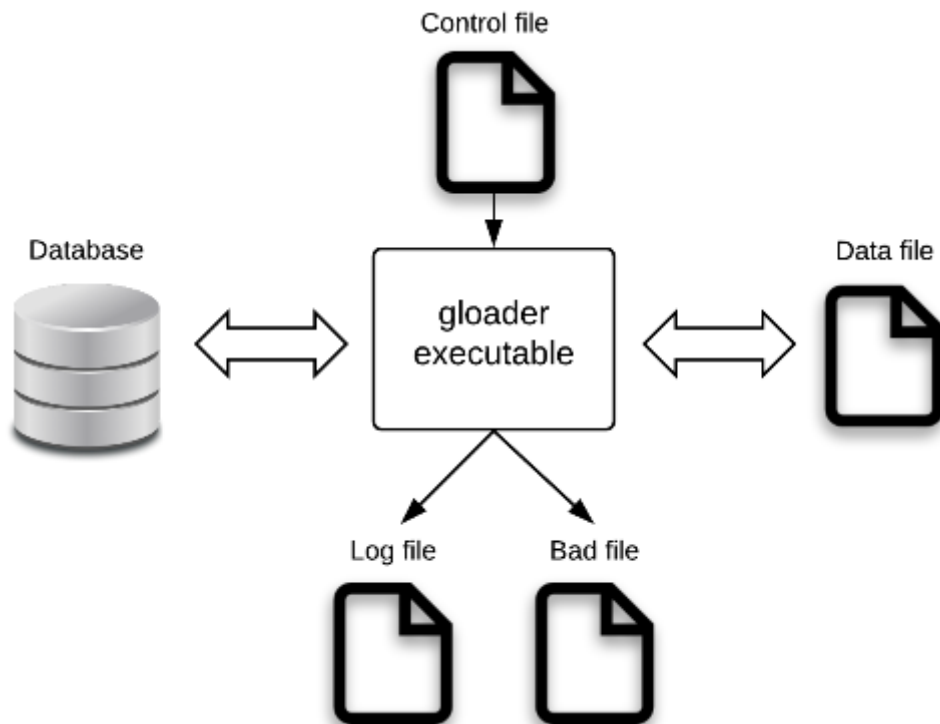

The control file and datafile are required to upload the data, then the log file is generated as a result. The control file is required to download the data, then the datafile, log file, and bad file are generated as the results.

## Control File

The control file is a file for operating gloder and it includes the following information. (Refer to **Control File Syntax**.)

- Table name
- Schema name
- The delimiter between columns in a row
- The qualifier notifying the start and end of the data
- The delimiter between rows
- Character set
- Whether to trim the whitespace character
- Where clause

## DataFile

The datafile should be prepared when gloder uploads the data, and it is created when gloder downloads the data.

The datafile supports text format and binary format.

- The datafile in text format has an advantage of which the file contents can be checked and directly updated.
- The datafile in binary format can be performed faster comparing to the datafile in text format.



gloder uses direct I/O for the data file by default. gloder arbitrarily adjusts the file size if the file size is not an array appropriate for direct I/O when uploading the data file by using direct I/O.

## Log File

Log file is a file which stores the following errors and results which occur while operating gloder.

- The row number and cause of the error
- The operating results of gloder

## Bad File

Bad file is a file which stores the rows in which an error occurred while gloder uploads the data. The delimiter between columns and rows, and the qualifier which are used to store the bad file should be user-defined.

## Example

The following is an example of downloading and uploading data by using gloder.

A table is created by using the SQL statement as follows.

```
$ cat test.sql
CREATE TABLE TEST
(
TEST_NAME VARCHAR(60),
TEST_NUM INTEGER,
TEST_TIME TIMESTAMP(0) WITH TIME ZONE
);
INSERT INTO TEST VALUES
( 'NAME', 1, '1999-01-08 04:05:06.789 -8:00' );
INSERT INTO TEST VALUES
( 'NAME', 2, '1999-01-08 04:05:06.789 -8:00' );
INSERT INTO TEST VALUES
( 'NAME', 3, '1999-01-08 04:05:06.789 -8:00' );
COMMIT;
```

The control file is used as follows.

```
$ cat testctl
TABLE TEST
FIELDS TERMINATED BY ','
OPTIONALLY ENCLOSED BY '"'
LINES TERMINATED BY '\n'
```

- Export: It downloads the data.

```
$ gloder test test --export --control testctl --data test.dat --no-prompt
COMPLETED IN EXPORTING TABLE: PUBLIC.TEST, 3 RECORDS
$ cat test.dat
"NAME","1","1999-01-08 04:05:07. -08:00"
"NAME","2","1999-01-08 04:05:07. -08:00"
"NAME","3","1999-01-08 04:05:07. -08:00"
$ cat test.log
cat test.log
COMPLETED IN EXPORTING TABLE: PUBLIC.TEST, 3 RECORDS [ Start Time: 2010-1-1 01:01:01 End Time:
2010-1-1 01:01:01 Taken Time: 56496 micro-sec ]
```

- Import: It uploads the data.

```

$ cat import.dat
"NAME","1","1999-01-08 04:05:07. -08:00"
"NAME","2","1999-01-08 04:05:07. -08:00"
"NAME","3","1999-01-08 04:05:07. -08:00"
"FAIL","FAIL","FAIL"
$ gloder test test --import --control test.ctl --data import.dat --no-prompt
COMPLETED IN IMPORTING TABLE: PUBLIC.TEST, TOTAL 4 RECORDS, SUCCEEDED 3 RECORDS
$ gsql test test
gSQL> select * from test;
TEST_NAME TEST_NUM TEST_TIME
-----
NAME          1 1999-01-08 04:05:07.000000 -08:00
NAME          2 1999-01-08 04:05:07.000000 -08:00
NAME          3 1999-01-08 04:05:07.000000 -08:00
NAME          1 1999-01-08 04:05:07.000000 -08:00
NAME          2 1999-01-08 04:05:07.000000 -08:00
NAME          3 1999-01-08 04:05:07.000000 -08:00
6 rows selected.
$ cat import.log
Err Rec(4) Col(2): 22018(12006): data value is not a numeric literal
COMPLETED IN IMPORTING TABLE: PUBLIC.TEST, TOTAL 4 RECORDS, SUCCEEDED 3 RECORDS [ Start Time:
2010-1-1 01:01:01 End Time: 2010-1-1 01:01:01 Taken Time: 56496 micro-sec ]
$ cat import.bad
"FAIL","FAIL","FAIL"

```

## 40.2 Using gloder

### Datafile Type

#### Text Datafile

It is represented with a string which can be checked and edited by the user. A user can directly create, edit the file, or can download the data from the existing tables in the database. A user also can use the data in a text format downloaded from another DBMS products.

The description for the representation of the text type datafile is recorded in the control file.

#### Binary Datafile

The file consists of binary data. A user can not directly create or edit the binary datafile. The file is generated when downloading the data from the existing tables in the database.

The binary type file is uploaded faster than the text type because the data is written to the file appropriate to the data structure type defined in GOLDILOCKS.



When GOLDILOCKS databases' versions are different one another, then it is not recommended to upload/ download by using a binary datafile. Also, it may be required to change a column size when uploading/ downloading data between databases whose string sets are different.

### Downloading Data

#### Downloading in Text File

##### Simple Download

The following is the structure and data of the table to be downloaded.

```
$ cat test.sql
CREATE TABLE TEST ( I1 INTEGER PRIMARY KEY, I2 VARCHAR(10), I3 VARBINARY(10) );
INSERT INTO TEST VALUES( 1, 'LKH', X'10' );
INSERT INTO TEST VALUES( 2, 'KMM', X'A0' );
INSERT INTO TEST VALUES( 3, 'ksj', X'CD' );
COMMIT;
```

```
$ gsql test test
gSQL> SELECT * FROM TEST;
I1 I2 I3
-- --- --
 1 LKH 10
 2 KMM A0
 3 ksj CD
3 rows selected.
```

The following is the contents of the control file which is created to download the table data.

```
$ cat test.ctl
TABLE PUBLIC.test
FIELDS TERMINATED BY ','
```

The data in the table T1 is downloaded through gloder as follows.

```
$ gloder test test --export --control test.ctl --data test.dat
COMPLETED IN EXPORTING TABLE: PUBLIC.test, 3 RECORDS
```

The data in the table TEST is downloaded to the datafile as follows.

```
$ ls
test.ctl test.dat test.log
$ cat test.dat
1,LKH,10
2,KMM,A0
3,ksj,CD
```

## Whitespace Character

The following is the structure and data of the table to be downloaded.

```
$ cat test.sql
CREATE TABLE TEST ( I1 INTEGER PRIMARY KEY, I2 VARCHAR(10), I3 VARBINARY(10) );
INSERT INTO TEST VALUES( 1, ' L K H ', X'10' );
INSERT INTO TEST VALUES( 2, 'KIM
MM', X'A0' );
INSERT INTO TEST VALUES( 3, ' KIM S
J ', X'CD' );
COMMIT;
$ gsql test test
```

```
gSQL> SELECT * FROM TEST;
I1 I2      I3
-- ----- --
 1  L K H  10
 2 KIM     A0
   MM
 3  KIM S  CD
   J
3 rows selected.
```

- The control file without using OPTIONALLY ENCLOSED BY statement
  - The following is the contents of the control file which is created to download the table data.

```
$ cat test.ctl
TABLE PUBLIC.test
FIELDS TERMINATED BY ','
LINES TERMINATED BY '\n'
```

- The data in the table TEST is downloaded to the datafile as follows.

```
$ ls
test.ctl test.dat test.log
$ cat test.dat
1, L K H ,10
2,KIM
MM,A0
3, KIM S
J ,CD
```



The control file should be used with the OPTIONALLY ENCLOSED BY statement for the data including the white space to maintain the downloaded data and the uploaded data as same.

- The control file using OPTIONALLY ENCLOSED BY statement
  - The following is the contents of the control file which is created to download the table data.

```
$ cat test.ctl
TABLE PUBLIC.test
FIELDS TERMINATED BY ','
OPTIONALLY ENCLOSED BY ''''
```



```
LINES TERMINATED BY '\n'
```

- The data in the table TEST is downloaded to the datafile as follows.

```
$ ls
test.ctl test.dat test.log
$ cat test.dat
"1"," L K H ","10"
"2","KIM
MM","A0"
"3"," KIM S
J ","CD"
```

## Time Related Data Type

DATE, TIME, TIME WITH TIME ZONE, TIMESTAMP, TIMESTAMP WITH TIME ZONE are output in the property default format when downloaded.

The following is each data type of DATE, TIME WITH TIME ZONE, TIMESTAMP WITH TIME ZONE.

```
$ gsql test test
gSQL> SELECT PROPERTY_VALUE, INIT_VALUE FROM V$PROPERTY WHERE PROPERTY_NAME LIKE
'NLS_DATE_FORMAT';
PROPERTY_VALUE                INIT_VALUE
-----
YYYY-MM-DD                    YYYY-MM-DD
1 row selected.
gSQL> SELECT PROPERTY_VALUE, INIT_VALUE FROM V$PROPERTY WHERE PROPERTY_NAME LIKE
'NLS_TIME_WITH_TIME_ZONE_FORMAT';
PROPERTY_VALUE                INIT_VALUE
-----
HH24:MI:SS.FF6 TZH:TZM        HH24:MI:SS.FF6 TZH:TZM
1 row selected.
gSQL> SELECT PROPERTY_VALUE, INIT_VALUE FROM V$PROPERTY WHERE PROPERTY_NAME LIKE
'NLS_TIMESTAMP_WITH_TIME_ZONE_FORMAT';
PROPERTY_VALUE                INIT_VALUE
-----
YYYY-MM-DD HH24:MI:SS.FF6 TZH:TZM YYYY-MM-DD HH24:MI:SS.FF6 TZH:TZM
1 row selected.
```

The following is the structure and data of the table to be downloaded.

```

$ cat test.sql
CREATE TABLE TEST ( I1 INTEGER, I2 DATE, I3 TIME WITH TIME ZONE, I4 TIMESTAMP WITH TIME ZONE
);
INSERT INTO TEST VALUES ( 1, '1999-12-31', '01:01:01', '1999-12-31 01:01:01.789 -8:00' );
INSERT INTO TEST VALUES ( 2, '2000-01-01', '23:12:12', '2000-01-01 23:12:06.0 +8:00' );
INSERT INTO TEST VALUES ( 3, '2000-12-31', '23:12:12', '2000-12-31 23:12:12.0 -8:00' );
COMMIT;
$ gsql test test
gSQL> SELECT * FROM T1;
I1 I2          I3                      I4
-----
 1 1999-12-31 01:01:01.000000 +09:00 1999-12-31 01:01:01.789000 -08:00
 2 2000-01-01 23:12:12.000000 +09:00 2000-01-01 23:12:06.000000 +08:00
 3 2000-12-31 23:12:12.000000 +09:00 2000-12-31 23:12:12.000000 -08:00
3 rows selected.

```

The following is the contents of the control file which is created to download the table data.

```

$ cat test.ctl
TABLE PUBLIC.test
FIELDS TERMINATED BY ','
OPTIONALLY ENCLOSED BY '"'
LINES TERMINATED BY '\n'

```

The data in the table TEST is downloaded to the datafile as follows.

```

$ gloder test test -e -c test.ctl -d test.dat
COMPLETED IN EXPORTING TABLE: PUBLIC.TEST, 3 RECORDS
$ ls
test.ctl test.dat test.log
$ cat test.dat
"1","1999-12-31 00:00:00","01:01:01.000000 +09:00","1999-12-31 01:01:01.789000 -08:00"
"2","2000-01-01 00:00:00","23:12:12.000000 +09:00","2000-01-01 23:12:06.000000 +08:00"
"3","2000-12-31 00:00:00","23:12:12.000000 +09:00","2000-12-31 23:12:12.000000 -08:00"

```

## Downloading in Binary File

### Simple Download

The following is the structure and data of the table to be downloaded.

```

$ cat test.sql
CREATE TABLE TEST ( I1 INTEGER PRIMARY KEY, I2 VARCHAR(10), I3 VARBINARY(10) );
INSERT INTO TEST VALUES( 1, 'LKH', X'10' );
INSERT INTO TEST VALUES( 2, 'KMM', X'A0' );
INSERT INTO TEST VALUES( 3, 'ksj', X'CD' );
COMMIT;
$ gsql test test
gSQL> SELECT * FROM TEST;
I1 I2 I3
-- --- --
 1 LKH 10
 2 KMM A0
 3 ksj CD
3 rows selected.

```

The following is the contents of the control file which is created to download the table data.

```

$ cat test.ctl
TABLE PUBLIC.test
FIELDS TERMINATED BY ','

```

The data in the table TEST is downloaded through gloder as follows.

```

$ gloder test test --export --control test.ctl --data test.dat --format binary
COMPLETED IN EXPORTING TABLE: PUBLIC.test, 3 RECORDS

```

The following file is generated after executing gloder.

```

$ ls
test.ctl test.dat test.log

```



A user can not directly check or edit the binary file.

## Complex Download

The following is the structure and data of the table to be downloaded.

```

$ gsql test test
gSQL>\desc TEST
COLUMN_NAME TYPE IS_NULLABLE
-----

```

```

I1          NUMBER(10,0)          TRUE
I2          DATE                  TRUE
I3          TIME(6) WITH TIME ZONE TRUE
I4          TIMESTAMP(6) WITH TIME TRUE
gSQL> SELECT COUNT(*) FROM TEST;
COUNT(*)
-----
1572864
1 row selected.

```

The following is the contents of the control file which is created to download the table data.

```

$ cat test.ctl
TABLE PUBLIC.test
FIELDS TERMINATED BY ','

```

- Downloading in a single file
  - The data in the table TEST is downloaded through gloder as follows.

```

$ gloder test test --export --control test.ctl --data test.dat --format binary
loaded 1000 records into PUBLIC.TEST
loaded 2000 records into PUBLIC.TEST
... Ellipsis ...
loaded 1571000 records into PUBLIC.TEST
loaded 1572000 records into PUBLIC.TEST
COMPLETED IN EXPORTING TABLE: PUBLIC.TEST, TOTAL 1572864 RECORDS

```

- The following file is generated after executing gloder.

```

$ ll test.*
-rw-r--r-- 1 test test      71 2014-08-28 12:13 t1.ctl
-rw-r--r-- 1 test test 59930624 2014-08-28 12:49 t1.dat
-rw-r--r-- 1 test test    159 2014-08-28 12:49 t1.log

```

- Downloading in multiple files
  - The data in the table TEST is downloaded through gloder as follows.

```

$ gloder test test --export --control test.ctl --data test.dat --format binary --filesize
31461376
loaded 1000 records into PUBLIC.TEST
loaded 2000 records into PUBLIC.TEST

```

```
... Ellipsis ...
```

```
loaded 1571000 records into PUBLIC.TEST
```

```
loaded 1572000 records into PUBLIC.TEST
```

```
COMPLETED IN EXPORTING TABLE: PUBLIC.TEST, TOTAL 1572864 RECORDS
```

- The following file is generated after executing glloader.

```
$ ll test.*
```

```
-rw-r--r-- 1 test test      71 2014-08-28 12:13 test.ct1
```

```
-rw-r--r-- 1 test test 31461376 2014-08-28 13:02 test.dat
```

```
-rw-r--r-- 1 test test 28474880 2014-08-28 13:02 test.dat.001
```

```
-rw-r--r-- 1 test test     159 2014-08-28 12:49 test.log
```

## Uploading Data

### Uploading Text File

#### Simple Upload

The following is the table to be uploaded.

```
gSQL> \DESC TEST
COLUMN_NAME TYPE IS_NULLABLE
-----
I1 NUMBER(10,0) TRUE
I2 DATE TRUE
I3 TIME(6) WITH TIME ZONE TRUE
I4 TIMESTAMP(6) WITH TIME ZONE TRUE
gSQL> SELECT * FROM TEST;
no rows selected.
```

The following is the datafile to be uploaded.

```
$ cat test.dat
1,1999-12-31 00:00:00,01:01:01.000000 +09:00,1999-12-31 01:01:01.789000 -08:00
2,2000-01-01 00:00:00,23:12:12.000000 +09:00,2000-01-01 23:12:06.000000 +08:00
3,2000-12-31 00:00:00,23:12:12.000000 +09:00,2000-12-31 23:12:12.000000 -08:00
```

The datafile is uploaded with gloder and the result is output as follows.

```
$ gloder test test --import --control test.ctl --data test.dat
COMPLETED IN IMPORTING TABLE: PUBLIC.TEST, TOTAL 3 RECORDS, SUCCEEDED 3 RECORDS
$ gsql test test
gSQL> select * from test;
I1 I2 I3 I4
-----
1 1999-12-31 01:01:01.000000 +09:00 1999-12-31 01:01:01.789000 -08:00
2 2000-01-01 23:12:12.000000 +09:00 2000-01-01 23:12:06.000000 +08:00
3 2000-12-31 23:12:12.000000 +09:00 2000-12-31 23:12:12.000000 -08:00
3 rows selected.
```

## Whitespace Character

The following is the table to be uploaded.

```
gSQL> \DESC TEST
COLUMN_NAME TYPE IS_NULLABLE
-----
I1 NUMBER(10,0) TRUE
I2 CHARACTER VARYING(10) TRUE
I3 BINARY VARYING(10) TRUE
gSQL> SELECT * FROM TEST;
no rows selected.
```

- The datafile downloaded without using OPTIONALLY ENCLOSED BY statement in the control file
  - The datafile is downloaded without using OPTIONALLY ENCLOSED BY statement in the control file as follows. (Refer to **Downloading in Text File.**)

```
$ cat test.dat
1, L K H ,10
2,KIM
MM,A0
3, KIM S
J ,CD
```

- The datafile is uploaded with gloder and the result is output as follows. Even though New Line ('\n') exists in the data of the second and third records, but a qualifier notifying the start and end of the column data is not set, so it is recognized as a row identifier.

```
$ gloder test test --import --control test.ctl --data test.dat
COMPLETED IN IMPORTING TABLE: PUBLIC.TEST, TOTAL 5 RECORDS, SUCCEEDED 3 RECORDS
$ gsql test test
gSQL> select * from test;
I1 I2 I3
-- ----
1 L K H 10
2 KIM null
3 KIM S null
3 rows selected.
```

- The datafile downloaded using OPTIONALLY ENCLOSED BY statement in the control file
  - The datafile is downloaded by using the OPTIONALLY ENCLOSED BY statement of the control file

as follows. (Refer to **Downloading in Text File**.) Differently from the result above, New Line ('\n') is treated as a part of data in the result below.

```
$ cat test.dat
"1"," L K H ","10"
"2","KIM
MM","A0"
"3"," KIM S
J ","CD"
```

- The datafile is uploaded with gloder and the result is output as follows.

```
$ gloder test test --import --control test.ctl --data test.dat
COMPLETED IN IMPORTING TABLE: PUBLIC.TEST, TOTAL 5 RECORDS, SUCCEEDED 3 RECORDS
$ gsql test test
gSQL> select * from test;
I1 I2      I3
-- ----- --
 1  L K H  10
 2  KIM    A0
   MM
 3  KIM S  CD
   J
3 rows selected.
```

## Uploading Binary File

### Simple Upload

The following is the structure of the table to be uploaded.

```
gSQL> \DESC TEST
COLUMN_NAME TYPE                IS_NULLABLE
-----
I1          NUMBER(10,0)                TRUE
I2          CHARACTER VARYING(10)      TRUE
I3          BINARY VARYING(10)        TRUE
gSQL> SELECT * FROM TEST;
no rows selected.
```

The following is the content of the control file written to download the table data.



```
$ cat test.ctl
TABLE PUBLIC.test
FIELDS TERMINATED BY ','
```

The following is a file to be uploaded with glloader. *test.dat* was already downloaded when **Downloading in Binary File**.

```
$ ls
test.dat
```

The datafile is uploaded to the table TEST and the result is output as follows.

```
$ glloader test test --import --control test.ctl --data test.dat --format binary
COMPLETED IN IMPORTING TABLE: PUBLIC.TEST, TOTAL 3 RECORDS, SUCCEEDED 3 RECORDS
$ gsql test test
gSQL> SELECT * FROM TEST;
I1 I2 I3
-- --- --
 1 LKH 10
 2 KMM A0
 3 ksj CD
3 rows selected.
```

## Complex Upload

The following is the structure of the table to be uploaded.

```
gSQL> \DESC TEST
COLUMN_NAME TYPE IS_NULLABLE
-----
I1 NUMBER(10,0) TRUE
I2 CHARACTER VARYING(10) TRUE
I3 BINARY VARYING(10) TRUE
gSQL> SELECT * FROM TEST;
no rows selected.
```

The following is the datafile to be uploaded.

```
$ ll test.*
-rw-r--r-- 1 test test 71 2014-08-28 12:13 test.ctl
-rw-r--r-- 1 test test 31461376 2014-08-28 13:02 test.dat
-rw-r--r-- 1 test test 28474880 2014-08-28 13:02 test.dat.001
```

```
-rw-r--r-- 1 test test      159 2014-08-28 12:49 test.log
```

When uploading multiple downloaded files with `--filesize`, gloder should be separately performed for each datafile.

```
$ gloder test test --import --control test.ctl --data test.dat --format binary
COMPLETED IN IMPORTING TABLE: PUBLIC.TEST, TOTAL 860728 RECORDS, SUCCEEDED 2285000 RECORDS,
ERRORED 0 RECORDS
$ gloder test test --import --control test.ctl --data test.dat.001 --format binary
COMPLETED IN IMPORTING TABLE: PUBLIC.TEST, TOTAL 860728 RECORDS, SUCCEEDED 860728 RECORDS,
ERRORED 0 RECORDS
```

The upload result is as follows.

```
gSQL> select count(*) from test;
COUNT(*)
-----
3145728
1 row selected.
```

## Controlling Upload Unit

The data can be uploaded faster by using the options which is related to performance. For more information, refer to `--array`, `--commit`, `--atomic`.

The following is the datafile with approximately 380,000 records.

```
$ ll test.dat
-rw-r--r-- 1 test test 75092480 2014-08-28 15:59 test.dat
```

The following is the control file which is used for uploading.

```
$ cat test.ctl
TABLE PUBLIC.test
FIELDS TERMINATED BY ','
OPTIONALLY ENCLOSED BY ''
LINES TERMINATED BY '\n'
```

## Array Binding and Commit Cycle

The following gloder command uploads records to be bound in 5,000 unit and uploads records to be committed in 20,000 unit.

```
$ gloder test test --import --control test.ctl --data test.dat --array 5000 --commit 20000
loaded 5000 records into PUBLIC.TEST
loaded 10000 records into PUBLIC.TEST
loaded 15000 records into PUBLIC.TEST
... Ellipsis ...
loaded 3810000 records into PUBLIC.TEST
loaded 3815000 records into PUBLIC.TEST
loaded 3818244 records into PUBLIC.TEST
COMPLETED IN IMPORTING TABLE: PUBLIC.TEST, TOTAL 3818243 RECORDS, SUCCEEDED 3818243 RECORDS
```

The following is the result of executing gloder.

```
gSQL> SELECT I1, I2, I3 FROM TEST FETCH 3;
I1 I2 I3
-- -----
1 L K H 10
2 KIM A0
3 KIM S CD
3 rows selected.
gSQL> SELECT COUNT(*) FROM TEST;
COUNT(*)
-----
3818246
1 row selected.
```

## Array Binding and Atomic Option

The following gloder commands uploads records to be bound in 5000 unit with atomic INSERT, and 1,000 records are failed.

```
$ gloder test test --import --control test.ctl --data test.dat --array 5000 --atomic
loaded 5000 records into PUBLIC.TEST
loaded 10000 records into PUBLIC.TEST
loaded 15000 records into PUBLIC.TEST
... Ellipsis ...
loaded 38175000 records into PUBLIC.TEST
COMPLETED IN IMPORTING TABLE: PUBLIC.TEST, TOTAL 3818243 RECORDS, SUCCEEDED 3817243 RECORDS
```

The following is the result of executing gloder.

```
gSQL> SELECT I1, I2, I3 FROM TEST FETCH 3;
I1 I2 I3
```

```

-----
1 L K H 10
2 KIM A0
3 KIM S CD
3 rows selected.
gSQL> SELECT COUNT(*) FROM TEST;
COUNT(*)
-----
3817243
1 row selected.

```

The following is the result for the cause of the upload failure and they are recorded in the log file. The upload is failed because the non-numeric data is stored in the first column of the first record.

```

$ cat test.log
Err Rec(1) Col(1): 22018(12006): data value is not a numeric literal
Err Rec(1) Col(-1): HY000(19041): Failed to atomic execution
Err Rec(1001) Col(1): 22018(12006): data value is not a numeric literal
Err Rec(1001) Col(-1): HY000(19041): Failed to atomic execution
COMPLETED IN IMPORTING TABLE: PUBLIC.TEST, TOTAL 3818243 RECORDS, SUCCEEDED 3817243 RECORDS [
Start Time: 2014-8-28 16:46:42 End Time: 2014-8-28 16:46:52 Taken Time: 10084582 micro-sec ]

```

The following is the result of the records which failed to upload and they are recorded in the bad file. 1000 records were stored because it is uploaded in 500 array units.

```

"s1", " L K H ", "10"
"2", "KIM", "A0"
"3", " KIM S J ", "CD"
... Ellipsis ...

```



Array, commit options do not affect the execution result, but success or failure of INSERT in the atomic operation is treated in an array unit, so if a record is failed to upload, all records in a unit to which the records belong are treated as INSERT failure.

The cause of the first failed records of the array is recorded in the log file and the causes for failed record later is not recorded.

## Parallel Upload

gloder improves the performance of GOLDLOCKS by dividing the operation into parts and uploading them in thread unit. (Refer to **--parallel**.)

The following is the datafile with approximately 380,000 records.

```
$ ll test.dat
-rw-r--r-- 1 test test 75092480 2014-08-28 15:59 test.dat
```

The following is the control file which is used for uploading.

```
$ cat test.ctl
TABLE PUBLIC.test
FIELDS TERMINATED BY ','
OPTIONALLY ENCLOSED BY ''
LINES TERMINATED BY '\n'
```

The following gloder commands uploads records which is bound to a thread performing four uploads. It is uploaded in 5000 unit with INSERT, and 100 records are failed.

```
$ gloder test test --import --control test.ctl --data test.dat --array 5000 --parallel 4
loaded 5000 records into PUBLIC.TEST
loaded 10000 records into PUBLIC.TEST
loaded 15000 records into PUBLIC.TEST
... Ellipsis ...
loaded 3810000 records into PUBLIC.TEST
loaded 3815000 records into PUBLIC.TEST
COMPLETED IN IMPORTING TABLE: PUBLIC.TEST, TOTAL 3818243 RECORDS, SUCCEEDED 3818143 RECORDS
```

The following is the result of executing gloder.

```
gSQL> SELECT I1, I2, I3 FROM TEST FETCH 3;
I1 I2 I3
-- ----- --
1 L K H 10
2 KIM A0
3 KIM S CD
3 rows selected.
gSQL> SELECT COUNT(*) FROM TEST;
COUNT(*)
-----
3818143
1 row selected.
```

The cause of failure during the upload is recorded in the log file as follows.

```
$ cat test.log
Err Rec(1) Col(1): 22018(12006): data value is not a numeric literal
Err Rec(3) Col(1): 22018(12006): data value is not a numeric literal
Err Rec(5) Col(1): 22018(12006): data value is not a numeric literal
... Ellipsis ...
Err Rec(1001) Col(1): 22018(12006): data value is not a numeric literal
... Ellipsis ...
COMPLETED IN IMPORTING TABLE: PUBLIC.TEST, TOTAL 3818243 RECORDS, SUCCEEDED 3818143 RECORDS [
Start Time: 2014-8-28 16:46:42 End Time: 2014-8-28 16:46:52 Taken Time: 10084582 micro-sec ]
```

The following is a result of failed records recorded on the bad file during the upload. 100 records are stored.

```
"s1", " L K H ", "10"
"s2", "KIM", "A0"
"s3", " KIM S J ", "CD"
... Ellipsis ...
```



When uploading the data with multiple threads, the records in which errors occur after INSERT are stored in the log file and bad file. In this case, the order of records may not be as same as the order in the data files.

## Troubleshooting for Uploading

The record upload failure may occur by various causes. The failed record is stored in the bad file, and the information about the cause of failure is stored in the log file.

### Failure due to Redundant Constraint

**The redundant data is already in the constrained table to be uploaded. (primary key or unique index)**

The following is the structure of the table to be uploaded.

```
gSQL>\desc T1
COLUMN_NAME TYPE IS_NULLABLE
-----
I1 NUMBER(10,0) TRUE
I2 CHARACTER VARYING(10) TRUE
I3 BINARY VARYING(10) TRUE
gSQL> SELECT * FROM T1;
I1 I2 I3
-- -- --
1 LKH 10
2 KMM A0
3 ksj CD
3 rows selected.
```

The following is the datafile to be uploaded.

```
$ cat t1.dat
"1","LKH"
"4","SOS"
"5","OKO"
```

The followings are the upload result by using gloder, and the created log file and bad file. The upload is failed because the record violated a primary key constraint.

```
$ gloder test test -i -c t1.ct1 -d t1.dat
COMPLETED IN IMPORTING TABLE: PUBLIC.T1, TOTAL 3 RECORDS, SUCCEEDED 2 RECORDS
$
$ cat t1.log
```

```

Err Rec(1) Col(-1): 40002(16057): unique constraint (PUBLIC.T1_PRIMARY_KEY) violated
COMPLETED IN IMPORTING TABLE: PUBLIC.T1, TOTAL 3 RECORDS, SUCCEEDED 2 RECORDS [ Start Time:
2014-8-26 16:19:51 End Time: 2014-8-26 16:19:51 Taken Time: 15455 micro-sec ]
$
$ cat t1.bad
"1","LKH"

```

## Failure due to Date/time Format

The format can be set for the data type such as DATE, TIME, TIME WITH TIME ZONE, TIMESTAMP, TIMESTAMP WITH TIME ZONE, and it may cause the failure of upload using gloder.

The following is the table to be uploaded.

```

gSQL> \DESC T1
COLUMN_NAME TYPE IS_NULLABLE
-----
I1 NUMBER(10,0) TRUE
I2 TIMESTAMP(6) WITH TIME ZONE TRUE
gSQL> SELECT * FROM T1;
no rows selected.

```

The format of the TIMESTAMP WITH TIME ZONE on the server is as follows.

```

gSQL> SELECT PROPERTY_VALUE, INIT_VALUE FROM V$PROPERTY WHERE PROPERTY_NAME LIKE
'NLS_TIMESTAMP_WITH_TIME_ZONE_FORMAT';
PROPERTY_VALUE          INIT_VALUE
-----
YYYY-MM-DD HH24:MI:SS.FF6 TZH:TZM YYYY-MM-DD HH24:MI:SS.FF6 TZH:TZM

```

The following is the datafile to be uploaded.

```

$ cat t1.dat
"4","20000108 00:00:00"
"5","20000108 04:05:06"
"6","20000108 04:05:06"

```

The following is the result of executing upload by using gloder.

```

$ gloder test test -i -c t1ctl -d t1.dat

COMPLETED IN IMPORTING TABLE: PUBLIC.T1, TOTAL 3 RECORDS, SUCCEEDED 0 RECORDS

```



The cause and records of upload failure are stored in the log file and the bad file as follows.

```
$ cat t1.log
Err Rec(1) Col(2): HY000(12136): literal does not match format string
Err Rec(2) Col(2): HY000(12136): literal does not match format string
Err Rec(3) Col(2): HY000(12136): literal does not match format string
COMPLETED IN IMPORTING TABLE: PUBLIC.T1, TOTAL 3 RECORDS, SUCCEEDED 0 RECORDS [ Start Time:
2014-8-27 13:56:29 End Time: 2014-8-27 13:56:29 Taken Time: 20670 micro-sec ]
$ cat t1.bad
"4","20000108 00:00:00"
"5","20000108 04:05:06"
"6","20000108 04:05:06"
```

## Troubleshooting

The problem occurs when the data type format of the datafile and that of the data used on the server are different. The data type format of the datafile should be set to solve the problem. In this case, `.odbc.ini` is used.

The data type format is set in `.odbc.ini` file as follows.

```
$ cat .odbc.ini
[GOLDILOCKS]
HOST = 127.0.0.1
PORT = 21123
DATE_FORMAT = YYYYMMDD
TIME_FORMAT = HH24MISS
TIME_WITH_TIME_ZONE_FORMAT = HH24MISS TZHTZM
TIMESTAMP_FORMAT = YYYYMMDD HHMISS
TIMESTAMP_WITH_TIME_ZONE_FORMAT = YYYYMMDD HH:MI:SS
```

The following is the result of setting `.odbc.ini` and performing gloder again.

```
$ gloder test test -i -c t1ctl -d t1.dat
COMPLETED IN IMPORTING TABLE: PUBLIC.T1, TOTAL 3 RECORDS, SUCCEEDED 3 RECORDS
```



- The data type format set in `.odbc.ini` is applied to the entire column, and it can not be separately set.
- If the data type format is set in `.odbc.ini`, it is also applied when downloading to gloder.

## Failure Due to Lack of Capacity

gloder is performed and failed as follows.

```
$ gloder test test -i -c t1.ct1 -d t2.dat
loaded 4000 records into PUBLIC.T1
COMPLETED IN IMPORTING TABLE: PUBLIC.T1, TOTAL 4200 RECORDS, SUCCEEDED 0 RECORDS
```

It is failed due to lack of the space for datafile in the tablespace.

```
$ cat t1.log
Err Rec(1) Col(-1): HY000(14015): there is no extendible datafile in tablespace 'MEM_DATA_TBS'
Err Rec(2) Col(-1): HY000(14015): there is no extendible datafile in tablespace 'MEM_DATA_TBS'
... Ellipsis ...
COMPLETED IN IMPORTING TABLE: PUBLIC.T1, TOTAL 4200 RECORDS, SUCCEEDED 0 RECORDS [ Start Time:
2014-8-27 15:7:28 End Time: 2014-8-27 15:7:29 Taken Time: 317885 micro-sec ]
```

## Troubleshooting

The datafile of a tablespace should be extended or added to solve the problem.

For more information, refer to **ALTER TABLESPACE**.

## Datafile Analysis Failure

The field terminator, the qualifier, and the line terminator described in the control file may be different in the text datafile because of misuse.

The following is the structure of the table object to be uploaded.

```
gSQL>\desc T1
COLUMN_NAME TYPE IS_NULLABLE
-----
I1 NUMBER(10,0) TRUE
I2 CHARACTER VARYING(10) TRUE
I3 BINARY VARYING(10) TRUE
```

The following is the control file to be uploaded.

```
$ cat t1.ct1
TABLE T1
FIELDS TERMINATED BY ','
OPTIONALLY ENCLOSED BY ''
LINES TERMINATED BY '\n'
```

The following is the datafile to be uploaded.

```
$ cat t1.dat
'1',"LKH","aa"
"2","SOS","aa"
"5","OKO","00"
```

The following is the result of executing upload by using gloder.

```
$ gloder test test --import --control t1.ct1 --data t1.dat
COMPLETED IN IMPORTING TABLE: PUBLIC.T1, TOTAL 3 RECORDS, SUCCEEDED 1 RECORDS
```

The cause and records of upload failure are as follows.

```
$ cat t1.log
Err Rec(1) Col(1): 22018(12006): data value is not a numeric literal
COMPLETED IN IMPORTING TABLE: PUBLIC.TEST, TOTAL 3 RECORDS, SUCCEEDED 1 RECORDS [ Start Time:
2014-8-28 18:6:13 End Time: 2014-8-28 18:6:13 Taken Time: 18679 micro-sec ]
$
$ cat t1.bad
"2","SOS","aa"
'1',"LKH","aa"
```

## Troubleshooting

The records fail to analyze the data due to qualifier or delimiter which are used improperly. Therefore, to solve this problem, the field terminator, the qualifier and the delimiter in the control file and the datafile should be checked, then the datafile should be edited based on the records of the bad file.



The records which are failed to parse in the data analysis process are stored in the bad file, not in the log file.

## Uploading to Another Database Whose Character Set Is Different

Adjusting the column size may be required when downloading/ uploading data in binary type between databases whose character sets are different one another.

The following is the structure of the table object to be uploaded.

```
gSQL>\desc T1
COLUMN_NAME TYPE IS_NULLABLE
-----
```

```
I1          NUMBER(10,0)          TRUE
I2          CHARACTER VARYING(36) TRUE
```

The following is the table data, and it is a VARCHAR type, its size is 36 and is completely filled.

```
SELECT * FROM T1;
I1    I2
-----
1 일이삼사오육칠팔구십일이삼사오육칠팔
```

The following error occurs when downloading data above from UHC database then uploading to UTF8 database which has the same schema.

```
$ gloder test test -i -f binary -T T1 -d t1.dup
ERR-HY000(42023): byte length of data greater than column length.
ERROR: FAILED TO IMPORT TABLE PUBLIC.T1
```

## Troubleshooting

The data upload succeeds when adjusting the length of column I2 as follows.

Declare I2 as VARCHAR(18 CHAR), or declare I2 as VARCHAR(54) size.

```
gSQL>\desc T1
COLUMN_NAME TYPE                                IS_NULLABLE
-----
I1          NUMBER(10,0)          TRUE
I2          CHARACTER VARYING(18 CHAR) TRUE
```

```
gSQL>\desc T1
COLUMN_NAME TYPE                                IS_NULLABLE
-----
I1          NUMBER(10,0)          TRUE
I2          CHARACTER VARYING(54) TRUE
```

## 40.3 Control File Syntax

```
TABLE [schema_name.]table_name[domain_name.]
FIELDS TERMINATED BY 'Field Terminator'
[OPTIONALLY ENCLOSED BY 'Open Qualifier' [AND 'Close Qualifier']]
[LINES TERMINATED BY 'Line Terminator']
[Character set character set_name]
[RTRIM [ON|OFF]]
[LTRIM [ON|OFF]]
[WHERE="conditional statement"]
```



A control file describes only one table. Therefore, each item above should be described in the control file only once, and if it is described redundantly, then the control parsing error occurs.

## CHARACTERSET

### Syntax

```
CHARACTERSET character set_name
```

### Description

It refers to the character set of the datafile to be downloaded or uploaded.

If the character set is not specified, the UTF8 which is the default character set of CHARACTER\_SET in GO LDILOCKS property is used.

### Example

The following is an example of which the character set of the datafile to be uploaded or downloaded is the ASCII code.

```
% cat sample.ctl
CHARACTERSET ASCII
```

# TABLE

## Syntax

```
TABLE table_name
TABLE schema_name.table_name
TABLE table_name@domain_name
TABLE schema_name.table_name@domain_name
```

## Description

It specifies the name of table to which upload or download the data, or specifies the schema name to which the table belongs, or the domain name.

The domain name can be used only for data download, and it downloads only the data of the corresponding member.

The string or double-quoted (") string is used in the table name.

If the table name is given as the command row argument in gloder as well, then the value of the command row argument takes precedence over the value in the control file.

## Examples

The following is an example of specifying only the table name.

```
% cat sample.ctl
TABLE lineitem
```

The following is an example of specifying the schema PUBLIC and the table name. It has the same meaning as the example above.

```
% cat sample.ctl
TABLE PUBLIC.lineitem
```

The following is an example of specifying the schema PUBLIC and the table name of G1N1 member. It has the same meaning as the example above.

```
% cat sample.ctl
TABLE PUBLIC.lineitem@G1N1
```

The following is an example of specifying the table name created by the delimited identifier.

```
gSQL> CREATE TABLE "Tab*&^" ( id INTEGER );
```

```
% cat sample.ctl  
TABLE "Tab*&^"
```

## FIELDS TERMINATED BY

### Syntax

```
FIELDS TERMINATED BY 'Field Terminator'
```

### Description

The field terminator is used as a delimiter between columns in the record data of the data file. Setting the field terminator in the control file can not be omitted.

The field terminator can be set with one or more strings, and should not be redundant with a qualifier or line terminator, and it should not use the subset string.

There is not any constraint for the string to be set as a field terminator. However, \ or % should be added to in front of each n, t, r when setting NEW LINE or TAB, CARRIAGE RETURN character.

If the field terminator is given as the command row argument in gloder as well, then the value of the command row argument takes precedence over the value in the control file.

### Example

The following is an example of setting the field terminator as COMMA and NEW LINE.

```
% cat sample.ctl  
FIELDS TERMINATED BY ',\n'
```

```
% cat sample.ctl  
FIELDS TERMINATED BY ',%n'
```

## OPTIONALLY ENCLOSED BY

## Syntax

OPTIONALLY ENCLOSED BY 'Open Qualifier' [AND 'Close Qualifier']

## Description

Qualifier is used as a delimiter to represent the start and end of the column.

Qualifier is a single character, and the first qualifier is a open qualifier, the last qualifier is a close qualifier. The same characters can be used to set an open qualifier and a close qualifier, or the different characters can be used to represent the start and end of the column.

Characters set as a qualifier can not be used in a field terminator nor in a line terminator.

If a close qualifier literally belongs to a column data, two close qualifiers are used to represent a single valid data.

If an open qualifier is set omitting a close qualifier, then characters as same as those in an open qualifier is set in a close qualifier.

If OPTIONALLY ENCLOSED BY statement does not exist, the column data is distinguished by the field terminator.

If the qualifier is given as the command row argument in gloder as well, then the value of the command row argument takes precedence over the value in the control file.



If OPTIONALLY ENCLOSED BY statement does not exist, the results of the uploading and downloading data may be different. (Refer to **Troubleshooting Uploading.**)

## Example

The following is an example of using double quotes (") and a single quote (') as a open qualifier and a close qualifier each.

```
% cat samplectl
OPTIONALLY ENCLOSED BY ''' AND '''
```

## LINES TERMINATED BY

## Syntax



## LINES TERMINATED BY 'Line Terminator'

The line terminator is used as a delimiter between records in the data file.

The line terminator can be set with one or more strings, and should not be redundant with a qualifier or a field terminator, and it should not use the subset string.

When omitting the line terminator setting, then NEW LINE ('\n' or '%n') is used by default.

If the line terminator is given as the command row argument in gloder as well, then the value of the command row argument takes precedence over the value in the control file.

## Description



- Differently from Unix, CARRIAGE RETURN and NEW LINE are written together instead of a single NEW LINE in the data file exported from Windows OS. When importing data by using this data file, LINES TERMINATED BY in the control file should be explicitly set like as '\r\n' so that the data is normally imported.
- It is recommended to set a field terminator and a line terminator with a different string each. The more mutual string including the first character exist the poorer the import performance due to the internal comparing. In other words, when a field terminator and a line terminator are set with different strings each, then the shorter the string the better the performance.

## Example

The following is an example of using '^^\t\r\n' as a line terminator

```
% cat sample.ctl
LINES TERMINATED BY '^^\t\r\n'
```

## LTRIM

## Syntax

```
LTRIM ON|OFF
```

## Description

It determines a left trim.

The default value is OFF, and when it is set to OFF, then the left WHITESPACE is considered data.

When it is set to ON, then the left WHITESPACE is ignored.



OPTIONALLY ENCLOSED BY is applied only when the syntax does not exist.

If OPTIONALLY ENCLOSED BY is used and the column is enclosed with delimiters in the data file, then RTRIM and LTRIM is OFF.

## Example

The following is an example of setting LTRIM to ON.

```
% cat sample.txt  
LTRIM ON
```

## RTRIM

### Syntax

```
RTRIM ON|OFF
```

## Description

It determines a right trim.

The default value is OFF, and when it is set to OFF, then the right WHITESPACE is considered data.

When it is set to ON, then the right WHITESPACE is ignored.



OPTIONALLY ENCLOSED BY is applied only when the syntax does not exist.

If OPTIONALLY ENCLOSED BY is used and the column is enclosed with delimiters in the data file, then RTRIM and LTRIM is OFF.

## Example

The following is an example of setting RTRIM to ON.

```
% cat sample.ctl  
RTRIM ON
```

## WHERE

### Syntax

```
WHERE="conditional_statement"
```

### Description

It uses a conditional clause when downloading data.

## Example

The following is an example of using WHERE.

```
% cat sample.ctl  
WHERE="I2 > 3"
```

## 40.4 gloder Argument References

### Usage

```
$ gloder --help
Usage
    gloder user password mode data [control] [format] [options]
    user          user name
    password      password
mode: gloder's mode.
    --export      export data
    --import      import data
data:
    --data        data file
options:
    --control     control file
    --format      file format(text|binary, Default text)
    --log         log file
    --bad         bad file
    --dsn         dsn string
    --array       number of rows in bind array(Default 1000)
    --filesize    max file size
    --commit      number of commit unit(Default 5000)
    --comment     commenting on commit
    --atomic      use atomic function
    --parallel    use parallel in import
    --propagation enabling or disabling a redo log propagation(ON|OFF)
    --errors      number of error count to allow(Default 100)
    --AsTIMESTAMP bind DATE as TIMESTAMP
    --buffered    buffered disk io(Default direct io)
    --tablename  [schema_name.]table_name[@domain_name]
    --fieldterm   field terminator
    --lineterm    line terminator
    --qualifier   qualifier(column data encloser)
    --where       export only rows selected by given WHERE condition
    --group-id    importing distributed data by group id using global connections in a
clustered environment
    --directio-size direct io size(Default 512)
```

<code>--no-copyright</code>	suppresses the display of the banner
<code>--silent</code>	suppresses the display of the result message
<code>--help</code>	print help message

## Mandatory Argument

The arguments are entered in an order of username and password to connect to the database. gloader operation mode, control file, datafile are entered as arguments.

Argument	Description
user_name	It is the user name. The maximum length of user name is 128.
password	It is password. The maximum length of password is 128.

### --export

#### Description

It specifies for gloader to download the data in the database.

#### Example

```
$ gloader test test --export -c sample.ctl -d sample.dat
```

### --import

#### Description

It specifies for gloader to upload the data in the database.

#### Example

```
$ gloader test test --import -c sample.ctl -d sample.dat
```

### --control

#### Description

It specifies the control file path.

If `--tablename` is given as an argument, the control file can be omitted. The table name is mandatory to e

execute gloder, so the table name should be given via a control file or an argument. If the table name is not given as an argument, TABLE item should be set via a control file.

When a control file is omitted, a field terminator, a qualifier, a line terminator can be given as an argument. If these delimiters are not given as an argument, then delimiters in CSV form is used by default.

## Example

The following is an example of using a control file whose name is sample.ctl.

```
$ gloder test test -i --control sample.ctl -d sample.dat
```

## --data

### Description

It specifies the data file path to download or upload.

### Example

The following is an example of uploading a control file whose name is sample.ctl.

```
$ gloder test test -i -c sample.ctl --data sample.dat
```

## Optional Argument

## --tablename

### Description

It specifies the table name in [Schemaname.]Tablename[@domain\_name] form.

The table name should be given via setting TABLE of an argument or a control file. In other words, if a control file is omitted, the table name argument is mandatory.

If a tablename argument is given when TABLE item of a control file is set, then argument value takes precedence over the value in the control file.

### Example

The following is an example of uploading data in CSV form by giving a tablename argument because the control file argument is omitted

```
$ gloader test test -i --tablename PUBLIC.T1 --data sample.dat
```

The following is an argument of omitting a tablename argument because TABLE item is omitted in the control file.

```
$ cat sample.ctl | grep TABLE
TABLE T1
$ gloader test test -i -c sample.ctl --data sample.dat
```

## --format

### Description

It specifies the datafile format.

The datafile format may be text or binary, and the default value is text when the format is not set.

### Example

The following is an example of downloading the data to sample.dat in binary form.

```
$ gloader test test --export --control sample.ctl --data sample.dat --format binary
```

The followings are sample.dat and sample.log which are created after executing gloader as above.

```
$ ls
sample.ctl sample.dat sample.log
```

## --log

### Description

It specifies the logfile path.

gloader records the error and results occurred during the execution.

If the file name is not specified, the name is created as same as the datafile by changing its extension to log.

### Example

The following is an example of when the name of the log file is specified by using --log option.

```
$ gloder test test --export --control sample.ct1 --data sample.dat --log SAMPLE.log
```

The followings are sample.dat, SAMPLE.log which are created after executing gloder as above.

```
$ ls  
sample.ct1 sample.dat SAMPLE.log
```

The following is an example of when the name of the log file is not specified by using --log option.

```
$ gloder test test --export --control sample.ct1 --data sample.dat
```

The followings are sample.dat, sample.log which are created after executing gloder as above.

```
$ ls  
sample.ct1 sample.dat sample.log
```

## --bad

### Description

It specifies the bad file path.

It is valid only when gloder performs the import operation. Rows which can not be uploaded due to an error are stored in the bad file.

If the file name is not specified, the name is created as same as the datafile by changing its extension to bad.

### Example

The following is an example of when the name of the bad file is specified by using --bad option.

```
$ gloder test test --import --control sample.ct1 --data sample.dat --bad SAMPLE.bad
```

The followings are sample.dat, sample.log, SAMPLE.bad which are created after executing gloder as above.

```
$ ls  
SAMPLE.bad sample.ct1 sample.dat sample.log
```

The following is an example of when the name of the bad file is not specified by using --bad option.

```
$ gloder test test --export --control sample.ct1 --data sample.dat
```

The followings are sample.dat, sample.log, sample.bad which are created after executing gloder as above.



e.

```
$ ls
sample.bad sample.ctl sample.dat sample.log
```

## --dsn

### Description

It is the dsn string. The maximum length is 128.

It is used to specify the format of the time-related data type represented in the data file to be downloaded or uploaded.

It is used to specify the server when using gloadernet in the Client/ Server (C/S) environment.

For more information, refer to **odbc.ini File**.

### Example

The following is an example of .odbc.ini described to use --dsn option.

```
$ cat .odbc.ini
[GOLDILOCKS]
HOST = 127.0.0.1
PORT = 21123
DATE_FORMAT = YYYYMMDD
TIME_FORMAT = HH24MISS
TIME_WITH_TIME_ZONE_FORMAT = HH24MISS TZHTZM
TIMESTAMP_FORMAT = YYYYMMDD HHMISS
TIMESTAMP_WITH_TIME_ZONE_FORMAT = YYYYMMDD HH:MI:SS
```

The following is an example of uploading the data to the goldilocks server by using --dsn option.

```
$ gloadernet test test --dsn goldilocks --import --control sample.ctl --data sample.dat
```

The following is an example of defining the format of time-related data type of the data file by using --dsn option, and then downloading data.

```
$ gloader test test --dsn goldilocks --export --control sample.ctl --data sample.dat
```

For more information, refer to **Failure due to date/time format**.

## --array

### Description

It specifies the number of rows to be bound when importing the data.

The amount of memory is required in proportion to the number of array. If not specified, 1,000 rows are used.

The option is applied only when uploading the data.

### Example

The following is an example of uploading the data file in 2,000 records unit.

```
$ gloder test test --import --control sample.ctl --data sample.dat --array 2000
```

## --filesize

### Description

The maximum size of the file can be set when gloder downloads the data. If the amount of data exceeds the maximum size, the file is generated by adding the permutation number to the file extension.

If not specified, the maximum file size is unlimited, and the minimum is 31,461,376 (30 Mbytes).

The option is valid only for the binary type data file.

### Example

The following is an example of executing the commands, then the file size exceeds the specified maximum, so new files are generated as results.

```
$ gloder test test --export --control sample.ctl --data sample.dat --filesize 31461376
```

```
$ls -al
-rw-r--r-- 1 test test 31461376 sample.dat
-rw-r--r-- 1 test test 31461376 sample.dat.001
-rw-r--r-- 1 test test 6715392 sample.dat.002
```

## --commit

### Description

While gloader uploads the data, the transaction is in the no commit state. The commit cycle may be set by using `--commit` option.

If not set, the default value is 5,000 (rows).

## Example

The following is an example of using `--commit` option.

```
$ gloader test test --import --control sample.ctl --data sample.dat --commit 10000
```

## --comment

### Description

When gloader commits the transaction, it specifies the comment on the transaction.

### Example

The following is an example of using `--comment` option.

```
$ gloader test test --import --control sample.ctl --data sample.dat --comment import_sample
```

## --atomic

### Description

It is the option for performing array INSERT, and it is useful when uploading the data.

The performance is faster than the existing array insert, because atomic array INSERT processes the insert statements as many as the size of array in a single transaction.

### Example

The following is an example of using `--atomic` option.

```
$ gloader test test --import --control sample.ctl --data sample.dat --array 1000 --atomic
```

## --parallel

### Description

It specifies the number of threads for parallel processing.

It is useful only when gloader uploads the data, and the performance gets faster when the number of thr

eads is increased by adjusting `--parallel` option.

The performance gets faster by increasing the number of threads, but it is recommended to set the number of threads according to the operational environment.

The default value is 1, and the maximum value is 32.

## Example

The following is an example of using eight threads when uploading data. Ten threads are operated together including threads analyzing the data files and read only threads, besides the eight uploading threads.

```
$ gloder test test --import --control sample.ctl --data sample.dat --parallel 8
```

## --propagation

### Description

It determines whether to propagate the upload transaction log to another replicated server. It can be set to ON or OFF.

### Example

The following is an example of which the upload transaction log is not propagated to another replicated server.

```
$ gloder test test --import --control sample.ctl --data sample.dat --propagation off
```

## --errors

### Description

It sets the number of errors permitted when gloder uploads the data.

If not set, 100 (rows) are used. If it is set to 0, the `--errors` option is ignored.

If it is smaller than the size of `--array` option, the number of permitted error is the number of array.

### Example

The following is an example of using `--errors` option.

```
$ gloder test test --import --control sample.ctl --data sample.dat --errors 10000
```

## --AsTIMESTAMP

### Description

It sets the DATE type data stored in TIMESTAMP format to be operated in TIMESTAMP format for backward compatibility.

TIMESTAMP\_FORMAT is also applied to the DATE type data when using the --AsTIMESTAMP option.

### Example

The following is an example of using --AsTIMESTAMP option.

```
$ gloader test test --import --control sample.ctl --data sample.dat --AsTIMESTAMP
```

## --buffered

### Description

Only the datafile uses the buffered IO instead of the direct IO.

The log file and bad file use the buffered IO.

### Example

The following is an example of using --buffered option.

```
$ gloader test test --import --control sample.ctl --data sample.dat --buffered
```

## --fieldterm

### Description

It provides a field terminator.

If it is set in a control file as well, then the fieldterm argument value is preferentially used.

% is added in front of n, r, t each for NEW LINE, CARRIAGE RETURN, TAB.

Characters which is used as a shell meta character such as ', ", \, & is not recommended to use.

### Example

The following is an example of using --fieldterm option.

```
$ gloader test test --i -c sample.ctl -d sample.dat --fieldterm "..."  
$ gloader test test --i -c sample.ctl -d sample.dat --fieldterm ...
```

```
$ gloder test test --i -c sample.ctl -d sample.dat --fieldterm ',,,'
```

## --lineterm

### Description

It provides a line terminator.

If it is set in a control file as well, then the lineterm argument value is preferentially used.

The detailed usage is as same as that of the fieldterm argument.

### Example

The following is an example of using --lineterm option.

```
$ gloder test test --i -T PUBLIC.test -d sample.dat --lineterm ",,, "  
$ gloder test test --i -T PUBLIC.test -d sample.dat --lineterm ,,,  
$ gloder test test --i -T PUBLIC.test -d sample.dat --lineterm ',,,'
```

## --qualifier

### Description

It provides a qualifier which is to be added to the start and the end of the column data. Only a single character can be set as a qualifier.

If it is set in a control file as well, then the qualifier argument value is preferentially used.

The detailed usage is as same as that of the fieldterm argument.

### Example

The following is an example of using --qualifier option.

```
$ gloder test test --i -T PUBLIC.test -d sample.dat --qualifier "|"  
$ gloder test test --i -T PUBLIC.test -d sample.dat --qualifier ''
```

## --where

### Description

It downloads the data by setting a conditional clause for export operation.

If the where clause is also set in a control file, then the where argument value is preferentially used.

## Example

The following is an example of using `--where` option.

```
$ gloader test test --i -T PUBLIC.test -d sample.dat --where "I2 > 4"
```

## --group-id

### Description

It directly uploads the data to the corresponding group after sorting the data by group when uploading the data in the sharded table in the cluster environment.

If this option is used when uploading the data to the non-sharded table, the option is not valid.

This option is operated only in C/S environment, so it is valid only in gloadernet and it can be used only when uploading text files.

`--group-id` option uses **GLOBAL CONNECTION** of ODBC, so properties related to the **Data Source Configuration** should be set.

### Example

The following is odbc.ini configuration file to use the global connection.

```
$cat .odbc.ini
[GOLDILOCKS]
HOST=127.0.0.1
PORT = 22581
LOCALITY_AWARE_TRANSACTION=1
LOCATOR_DSN = LOCATOR
[LOCATOR]
LOCATOR_FILE=.locator.ini
```

The following is an example of using `--group-id` option in gloadernet.

```
$ gloadernet test test --i -T PUBLIC.test -d sample.dat --group-id
COMPLETED IN IMPORTING TABLE: PUBLIC.TEST, TOTAL 20 RECORDS, SUCCEEDED 20 RECORDS
```

The following is an example of an error which occurred due to using `--group-id` option in gloader.

```
$ gloader test test --i -T PUBLIC.test -d sample.dat --group-id
ERR-HY010(19009): Function sequence error : The function should be called only when the
SQL_ATTR_LOCALITY_AWARE_TRANSACTION connection attribute is set.
```

## **--directio-size**

### **Description**

gloder uses direct IO by default. The default value of direct IO is 512, but this size can be modified by using *--directio-size*. The value for the size should be the value of 2 powers of 512.

### **Example**

The following is an example of modifying the direct IO size in gloder.

```
$ gloder test test --i -T PUBLIC.test -d sample.dat --directio-size 1024
```

## **--no-copyright**

### **Description**

It does not output the copyright and version.

### **Example**

The following is the result of executing gloder with *--no-copyright* option.

```
$ gloder test test --import --control sample.ctl --data sample.dat --no-copyright  
COMPLETED IN EXPORTING TABLE: PUBLIC.t1, 3 RECORDS  
$
```

## **--silent**

### **Description**

It does not output the results of executing gloder.

### **Example**

The following is the result of executing gloder with *--silent* option.

```
$ gloder test test --import --control sample.ctl --data sample.dat --silent  
$
```



## --help

### Description

It displays the help messages.

For more information, refer to **Usage**.



**41.**

---

**gdump**

## 41.1 Overview of gdump

### Definition

gdump is a utility provided by GOLDILOCKS, and it dumps the following binary files managed by the data base in text form.

- Control file
- Datafile
- Log file
- Incremental backup file
- Property file
- Commit log file
- Log buffer file
- Pending log buffer file

### Argument

gdump usage is divided into the mandatory argument and the optional argument, and the optional arguments are used differently according to the file types to be dumped.

```
gdump file_type file_name [options]
```

### Mandatory Argument

The mandatory argument is used in an order of the file type and and the file path.

```
file_type: CONTROL | LOG | DATA | PROPERTY | BACKUP | COMMIT_LOG | LOG_BUFFER | PEND_BUFFER  
file_name: file name to dump
```

### file\_type Argument

- CONTROL: It is a control file. It is located in  $\langle \text{GOLDILOCKS\_DATA} \rangle / wal$ , and its file extension is *.ctl*.
- Log: It is a log file(Online/Archived redo log file). It is located in  $\langle \text{GOLDILOCKS\_DATA} \rangle / wal$  or in  $\langle \text{GOLDILOCKS\_DATA} \rangle / archive\_log$ , and its file extension is *.log*.
- DATA: It is a datafile. It is located in  $\langle \text{GOLDILOCKS\_DATA} \rangle / db$ , and its file extension is *.dbf*.
- PROPERTY: It is a binary property file. It is located in  $\langle \text{GOLDILOCKS\_DATA} \rangle / conf$ , and the default file name is *goldilocks.properties.binary*.

- **BACKUP:** It is an incremental backup file. It is located in `<GOLDILOCKS_DATA>/backup`, and its file extension is `.inc`.
- **COMMIT\_LOG:** It is a `commit.log` file located in `<GOLDILOCKS_DATA>/wal`.
- **LOG\_BUFFER:** It is a file of which a log buffer located in the memory is stored. The log buffer is stored in a file by executing `gsyncher`.
- **PEND\_BUFFER:** It is a file of which a pending log buffer located in the memory is stored. The pending log buffer is stored in a file by executing `gsyncher`.



An attempt to the dump of broken control file fails.

## Optional Argument

```

-S --silent                                silent
file_type = CONTROL
  -s, --section sys | log | db | backup | all  dump controlfile section(default all)
file_type = DATA
  -h, --header                                dump datafile header
  -n, --number INTEGER ( >= 0 )              (log or page) sequence number
  -f, --fetch INTEGER ( >= 1 )              dump as much as count
file_type = LOG
  -h, --header                                dump datafile header
  -n, --number INTEGER ( >= 0 )              (log or page) sequence number
  -o, --offset INTEGER                       offset of lsn(usable if set lsn)
  -f, --fetch INTEGER ( >= 1 )              dump as much as count
  -a, --all
file_type = BACKUP
  -b, --body header | all                    dump incremental body(default all)
  -t, --tbs                                  dump specific tablespace body(usage if set body)
  -n, --number INTEGER ( >= 0 )              (log or page) sequence number
  -f, --fetch INTEGER ( >= 1 )              dump as much as count

```

## Description

Name	Available file type	Description
<code>--silent</code>	All	It does not output copyright, version, the execution time.
<code>--section</code>	Control file	It refers to the section of control file to be dumped. <ul style="list-style-type: none"> <li>• <code>sys</code>: System section</li> <li>• <code>log</code>: Log section</li> <li>• <code>db</code>: Database section</li> </ul>

Name	Available file type	Description
		<ul style="list-style-type: none"> <li>• backup: Incremental backup section</li> <li>• all: All sections (The default value)</li> </ul>
--header	Datafile	It dumps only the header of the datafile. If not set, it does not display the header.
	Log file	It dumps only the header of the log file.
--number	Datafile	It is a page number to be dumped. (The default value is 0.)
	Log file	It is a log number to be dumped. (The default value is 0, and it dumps the log bigger than the specified number.)
	Incremental backup file	It is a page number to be dumped. (The default value is 0, and it dumps the page bigger than the specified number.)
--fetch	Datafile	It is a number of pages to be dumped. (The default value is 1.)
	Log file	It is a number of logs to be dumped. (The default value is the whole logs.)
	Incremental backup file	It is a number of pages to be dumped. (The default value is the whole pages.)
--offset	Log file	It is valid only when --number option argument is set, and it refers to the position apart as far as offset from the value set in number. (The default value is 0.)
--body	Incremental backup file	It displays the header of page (header) or the header and page (all). If not set, it does not display anything. (The default value is none).
--tbs	Incremental backup file	It is valid only when --body option is set. It specifies the certain tablespace number in the incremental backup file. If not set, it refers to all tablespace.
--all	Log file	It dumps all including invalid logs.



An option is not used when dumping the property file.

## 41.2 Examples of Using gdump

### Control File

- Dumping system section

```
$ gdump control control_0.ctl --section sys --silent
[SYSTEM SECTION]
```

```
-----
SERVER STATE           : SERVICE
DATA STORE MODE       : TDS
LAST CHECKPOINT LSN   : 136976
INCREMENTAL BACKUP CHUNK COUNT : 1
INCREMENTAL BACKUP SECTION OFFSET : 512
LOG SECTION OFFSET    : 8704
DB SECTION OFFSET     : 13312
```

- Dumping log section

```
$ gdump control control_0.ctl --section log --silent
[LOG SECTION]
```

```
-----
DATABASE CREATION TIME : 2014-08-25 18:37:11.299610
[CHECKPOINT]
LID           : 0,54834,13
LSN           : 136976
RECOVERY LSN  : 136976
ARCHIVELOG MODE : ARCHIVELOG
LAST INACTIVATED LOGFILE SEQUENCE : -1
[LOG STREAM]
STATE        : ACTIVE
GROUP COUNT  : 4
BLOCK SIZE   : 512
FILE SEQUENCE : 0
[LOG GROUP #0]
STATE        : CURRENT
SIZE         : 104857600
MEMBER COUNT : 1
FILE SEQUENCE : 0
```

```
PREV LAST LSN : -1
MEMBER #0      : "/home/lkh/work/product/Gliese/home/wal/redo_0_0.log"
```

- Dumping database section

```
$ gdump control control_0.ctl --section db --silent
[DB SECTION]
-----
[DATABASE]
TRANSACTION_TABLE_SIZE : 1024
UNDO_RELATION_COUNT    : 128
TABLESPACE COUNT       : 4
NEW TABLESPACE ID     : 4
[TABLESPACE #0]
NAME                    : DICTIONARY_TBS
ATTRIBUTES              : MEMORY | PERSISTENT | DICT
STATE                   : CREATED
LOGGING STATE           : LOGGING
ONLINE STATE            : ONLINE
EXTENT_SIZE             : 8
RELATION_ID             : 0
[DATAFILE #0]
SIZE                   : 134209536
STATE                  : CREATED
NAME                   : "/home/lkh/work/product/Gliese/home/db/system_dict.dbf"
```

- Dumping incremental backup section

```
$ gdump control control_0.ctl --section backup --silent
[INCREMENTAL BACKUP SECTION]
-----
[ BACKUP #0 ]
FILE PATH : /home/lkh/work/product/Gliese/home/backup/databaseD20140825T183902L0S0.inc
BACKUP LSN : 136976
BACKUP LEVEL : 0
BACKUP OBJECT : database
[ BACKUP #1 ]
FILE PATH : /home/lkh/work/product/Gliese/home/backup/controlD20140825T183904L0S0.inc
BACKUP LSN : 136976
BACKUP LEVEL : 0
BACKUP OBJECT : control
```



## Datafile

- Dumping the first page of datafile *system\_dict.dbf*

```
$ gdump data system_dict.dbf --silent
TABLESPACE ID : 0
DATAFILE ID : 0
PAGE SEQUENCE ID : 0
-----
[PHYSICAL HEADER] TYPE(EXT_BLOCK_MAP), FREENESS(FREE), LSN(107938),
TIMESTAMP(1408959438472006), PARENT RID(0,-1,0), SEGMENT ID(0), MAX VIEW SCN(0), AGABLE
SCN(0), SELF ID(0,0)
-----
0000    0200000004000000 A2A5010000000000 4643D5EE70010500 0000FFFF00000000
0020    0000000000000000 0000000000000000 0000000000000000 0300000000000000
0040    0000000000000000 0000000000000000 0000000000000000 0200000001000000
0060    0200000001000000 03200000001000000 0000000000000000 0000000000000000
0080    0000000000000000 0000000000000000 0000000000000000 0000000000000000
00A0    0000000000000000 0000000000000000 0000000000000000 0000000000000000
00C0    0000000000000000 0000000000000000 0000000000000000 0000000000000000
....
```

- Dumping three pages from the 100th page of datafile *system\_dict.dbf*

```
$ gdump data system_dict.dbf --number 100 --fetch 3 --silent
TABLESPACE ID : 0
DATAFILE ID : 0
PAGE SEQUENCE ID : 100
-----
[PHYSICAL HEADER] TYPE(BITMAP_HEADER), FREENESS(INSERTABLE), LSN(348),
TIMESTAMP(1408959438472006), PARENT RID(0,57,4), SEGMENT ID(4294967296), MAX VIEW SCN(0),
AGABLE SCN(0), SELF ID(0,1
00)
-----
0000    0400000003000000 5C01000000000000 4643D5EE70010500 0000390004000000
0020    0000000001000000 0000000000000000 0000000000000000 80C0317800000000
0040    0000000000000000 0000000000000000 0000000064000000 0100000001000002
0060    FFFFFFFFFFFFFFFF 0100000000000000 0000000000000000 0000000000000000
0080    0000000000000000 0200000001000000 7303000072030000 6E00010000000000
00A0    3700000000000000 0000000000000000 0000000000000000 0000000000000000
```

```
00C0 0000000000000000 0000000000000000 0000000000000000 0000000000000000
....
1FC0 0000000000000000 0000000000000000 0000000000000000 0000000000000000
1FE0 0000000000000000 0000000000000000 0000000000000000 5C01000000000000
TABLESPACE ID : 0
DATAFILE ID : 0
PAGE SEQUENCE ID : 101
```

-----  
[PHYSICAL HEADER] TYPE(BITMAP\_HEADER), FREENESS(INSERTABLE), LSN(353),  
TIMESTAMP(1408959438472006), PARENT RID(0,58,4), SEGMENT ID(4294967296), MAX VIEW SCN(0),  
AGABLE SCN(0), SELF ID(0,1  
01)

```
0000 0400000003000000 6101000000000000 4643D5EE70010500 00003A0004000000
0020 0000000001000000 0000000000000000 0000000000000000 00BF317800000000
0040 0000000000000000 0000000000000000 0000000065000000 0100000001000002
0060 FFFFFFFFFFFFFFFF 0100000000000000 0000000000000000 0000000000000000
0080 0000000000000000 0200000001000000 8303000082030000 7000010000000000
00A0 3800000000000000 0000000000000000 0000000000000000 0000000000000000
00C0 0000000000000000 0000000000000000 0000000000000000 0000000000000000
....
1FC0 0000000000000000 0000000000000000 0000000000000000 0000000000000000
1FE0 0000000000000000 0000000000000000 0000000000000000 6101000000000000
TABLESPACE ID : 0
DATAFILE ID : 0
PAGE SEQUENCE ID : 102
```

-----  
[PHYSICAL HEADER] TYPE(BITMAP\_HEADER), FREENESS(INSERTABLE), LSN(358),  
TIMESTAMP(1408959438472006), PARENT RID(0,59,4), SEGMENT ID(4294967296), MAX VIEW SCN(0),  
AGABLE SCN(0), SELF ID(0,1  
02)

```
0000 0400000003000000 6601000000000000 4643D5EE70010500 00003B0004000000
0020 0000000001000000 0000000000000000 0000000000000000 C0BD317800000000
0040 0000000000000000 0000000000000000 0000000066000000 0100000001000002
0060 FFFFFFFFFFFFFFFF 0100000000000000 0000000000000000 0000000000000000
0080 0000000000000000 0200000001000000 9303000092030000 7200010000000000
00A0 3900000000000000 0000000000000000 0000000000000000 0000000000000000
00C0 0000000000000000 0000000000000000 0000000000000000 0000000000000000
....
```

- Dumping the header of datafile *system\_dict.dbf*

```
$ gdump data system_dict.dbf --header --silent
FILE                : system_dict.dbf
Tablespace Physical Id : 0
Datafile Id         : 0
Last Checkpoint Lsn  : 136976
Creation TIME       : 2014-08-25 18:37:18.472006
```

## Log File

- It dumps all of online redo log file *redo\_0\_0.log*.

```
$ gdump log redo_0_0.log --silent
```

```
=====
[LOG FILE HEADER]
-----
LOG_GROUP_ID       : 0
BLOCK_SIZE         : 512
FILE_SIZE          : 104857600
FILE_SEQUENCE      : 0
PREV_LAST_LSN     : -1
CREATION TIME      : 2014-08-25 18:37:13.315283
=====
[LOG #0] : BLOCK(0), LSN(0), SIZE(1132), PIECE_COUNT(1), TRANS_ID(FFFFFFFFFFFF0001),
RID(0,-1,0)
[PIECE #0] : TYPE(MEMORY_FILE_CREATE), SIZE(1116), CLASS(DATAFILE), REDO_TYPE(CONTROL_FILE),
PROPAGATE_LOG(YES), RID(0,0,0)
  FFFFFFFF2F686F6D 652F6C6B682F776F 726B2F70726F6475 63742F476C696573    .../home/ellkh/work/produ ct/Glies
  652F686F6D652F64 622F73797374656D 5F646963742E6462 6600000000000000    e/home/db/system
  _dict.db f.....
  0000000000000000 0000000000000000 0000000000000000 0000000000000000    .....
  .....
[LOG #1] : BLOCK(3), LSN(1), SIZE(232), PIECE_COUNT(1), TRANS_ID(FFFFFFFFFFFF0001), RID(0,0,0)
[PIECE #0] : TYPE(MEMORY_TBS_CREATE), SIZE(216), CLASS(DATAFILE), REDO_TYPE(CONTROL_FILE),
PROPAGATE_LOG(YES), RID(0,0,0)
... Ellipsis ...
```

- It dumps three logs from a log which is away as far as five offsets from log sequence number 100 in r



```

000000000000000000 000000000000000000 000000000000000000 000000000000000000 .....
.....
000000000000000000 000000000000000000 01000000B2000000 .....
.....

```

## Incremental Backup File

- It dumps incremental backup information.
  - Only header and tail of file in *databaseD20140825T183902L0S0.inc* are dumped as follows.

```

$ gdump backup databaseD20140825T183902L0S0.inc --silent
INCREMENTAL FILE HEADER
-----
OBJECT TYPE(DATABASE), TBS COUNT(3), BODY SIZE(62742528)
LSN: PREV(0), MAX (136976), CHKPT(136976)
CHKPT LID: File Seq No(0), Block Info1(877344), Block Info2(13)
-----
INCREMENTAL FILE TAIL
-----
TABLESPACE ID(000), BACKUP PAGE COUNT(05372), TABLESPACE OFFSET(8192)
TABLESPACE ID(001), BACKUP PAGE COUNT(02090), TABLESPACE OFFSET(44015616)
TABLESPACE ID(002), BACKUP PAGE COUNT(00197), TABLESPACE OFFSET(61136896)

```

- It dumps header and body of page for the entire page of incremental backup.
  - The entire page of all tablespaces in *databaseD20140825T183902L0S0.inc* is dumped as follows.

```

$ gdump backup databaseD20140724T123414L0S0.inc --body all
INCREMENTAL FILE HEADER
-----
OBJECT TYPE(DATABASE), TBS COUNT(3), BODY SIZE(62742528)
LSN: PREV(0), MAX (136976), CHKPT(136976)
CHKPT LID: File Seq No(0), Block Info1(877344), Block Info2(13)
-----
INCREMENTAL FILE TAIL
-----
TABLESPACE ID(000), BACKUP PAGE COUNT(05372), TABLESPACE OFFSET(8192)
TABLESPACE ID(001), BACKUP PAGE COUNT(02090), TABLESPACE OFFSET(44015616)
TABLESPACE ID(002), BACKUP PAGE COUNT(00197), TABLESPACE OFFSET(61136896)
TABLESPACE ID : 0
DATAFILE ID : 0

```

PAGE SEQUENCE ID : 0

-----  
 [PHYSICAL HEADER] TYPE(EXT\_BLOCK\_MAP), FREENESS(FREE), LSN(107938),  
 TIMESTAMP(1408959438472006), PARENT RID(0,-1,0), SEGMENT ID(0), MAX VIEW SCN(0), AGABLE  
 SCN(0), SELF ID(0,0)

-----  
 0000 0200000004000000 A2A5010000000000 4643D5EE70010500 0000FFFF00000000  
 0020 0000000000000000 0000000000000000 0000000000000000 0000000000000000  
 0040 0000000000000000 0000000000000000 0000000000000000 0200000001000000  
 0060 0200000001000000 0320000001000000 0000000000000000 0000000000000000  
 0080 0000000000000000 0000000000000000 0000000000000000 0000000000000000

... Ellipsis ...

TABLESPACE ID : 0

DATAFILE ID : 0

PAGE SEQUENCE ID : 1

-----  
 [PHYSICAL HEADER] TYPE(BITMAP\_HEADER), FREENESS(FREE), LSN(100016),  
 TIMESTAMP(1408959438472006), PARENT RID(0,-1,0), SEGMENT ID(4294967296), MAX VIEW SCN(0),  
 AGABLE SCN(0), SELF ID(0,1)

-----  
 0000 0400000004000000 B086010000000000 4643D5EE70010500 0000FFFF00000000  
 0020 0000000001000000 0000000000000000 0000000000000000 802A327800000000  
 0040

... Ellipsis ...

TABLESPACE ID : 2

DATAFILE ID : 0

PAGE SEQUENCE ID : 24580

-----  
 [PHYSICAL HEADER] TYPE(EXT\_MAP), FREENESS(FREE), LSN(24), TIMESTAMP(1408959441642963),  
 PARENT RID(0,-1,0), SEGMENT ID(0), MAX VIEW SCN(0), AGABLE SCN(0), SELF ID(2,24580)

-----  
 0000 0300000004000000 1800000000000000 D3A505EF70010500 0000FFFF00000000  
 0020 0000000000000000 0000000000000000 0000000000000000 0000000000000000  
 0040 0000000000000000 0000000000000000 0200000004600000 1E001E0000001E00

... Ellipsis ...

- It dumps header and body of page whose page number is bigger than the specified number in incremental backup.
  - The pages whose page number is bigger than 1,000 of all tablespaces in *databaseD20140825T183902L050.inc* are dumped as follows.

```
$ gdump backup databaseD20140724T123414L0S0.inc --number 10000 --body all
```

```
INCREMENTAL FILE HEADER
```

```
-----
OBJECT TYPE(DATABASE), TBS COUNT(3), BODY SIZE(62742528)
LSN: PREV(0), MAX (136976), CHKPT(136976)
CHKPT LID: File Seq No(0), Block Info1(877344), Block Info2(13)
-----
```

```
INCREMENTAL FILE TAIL
```

```
-----
TABLESPACE ID(000), BACKUP PAGE COUNT(05372), TABLESPACE OFFSET(8192)
TABLESPACE ID(001), BACKUP PAGE COUNT(02090), TABLESPACE OFFSET(44015616)
TABLESPACE ID(002), BACKUP PAGE COUNT(00197), TABLESPACE OFFSET(61136896)
TABLESPACE ID : 2
DATAFILE ID : 0
PAGE SEQUENCE ID : 16387
-----
```

```
[PHYSICAL HEADER] TYPE(EXT_MAP), FREENESS(FREE), LSN(22), TIMESTAMP(1408959441642963),
PARENT RID(0,-1,0), SEGMENT ID(0), MAX VIEW SCN(0), AGABLE SCN(0), SELF ID(2,16387)
```

```
-----
0000 0300000004000000 1600000000000000 D3A505EF70010500 0000FFFF00000000
0020 0000000000000000 0000000000000000 0000000000000000 0000000000000000
0040 0000000000000000 0000000000000000 0200000003400000 0001000100000001
0060 0000000000000000 0000000000000000 0000000000000000 0000000000000000
0080 0000000000000000 0000000000000000 0000000000000000 0000000000000000
```

```
... Ellipsis ...
```

```
TABLESPACE ID : 2
DATAFILE ID : 0
PAGE SEQUENCE ID : 24580
-----
```

```
[PHYSICAL HEADER] TYPE(EXT_MAP), FREENESS(FREE), LSN(24), TIMESTAMP(1408959441642963),
PARENT RID(0,-1,0), SEGMENT ID(0), MAX VIEW SCN(0), AGABLE SCN(0), SELF ID(2,24580)
```

```
-----
0000 0300000004000000 1800000000000000 D3A505EF70010500 0000FFFF00000000
0020 0000000000000000 0000000000000000 0000000000000000 0000000000000000
0040 0000000000000000 0000000000000000 0200000004600000 1E001E0000001E00
0060 0000000000000000 0000000000000000 0000000000000000 0000000000000000
0080 0000000000000000 0000000000000000 0000000000000000 0000000000000000
```

```
... The rest is omitted ...
```

- It dumps header and body of page for the specified number of the specified tablespace in incremental backup.

- The page of number 1,000 in the tablespace of number 0 in *database D20140825T183902L0S0.inc* is dumped as follows.

```
gdump backup databaseD20140825T183902L0S0.inc --tbs 0 --number 1000 --body all --fetch 1
--silent | more
```

```
INCREMENTAL FILE HEADER
```

```
-----
OBJECT TYPE(DATABASE), TBS COUNT(3), BODY SIZE(62742528)
LSN: PREV(0), MAX (136976), CHKPT(136976)
CHKPT LID: File Seq No(0), Block Info1(877344), Block Info2(13)
-----
```

```
INCREMENTAL FILE TAIL
```

```
-----
TABLESPACE ID(000), BACKUP PAGE COUNT(05372), TABLESPACE OFFSET(8192)
TABLESPACE ID(001), BACKUP PAGE COUNT(02090), TABLESPACE OFFSET(44015616)
TABLESPACE ID(002), BACKUP PAGE COUNT(00197), TABLESPACE OFFSET(61136896)
TABLESPACE ID : 0
DATAFILE ID : 0
PAGE SEQUENCE ID : 1000
-----
```

```
[PHYSICAL HEADER] TYPE(UNFORMAT), FREENESS(FREE), LSN(6307), TIMESTAMP(1408959438472006),
PARENT RID(0,-1,0), SEGMENT ID(0), MAX VIEW SCN(0), AGABLE SCN(0), SELF ID(0,1000)
-----
```

```
0000  0100000004000000 A318000000000000 4643D5EE70010500 0000FFFF00000000
0020  0000000000000000 0000000000000000 0000000000000000 0000000000000000
0040  0000000000000000 0000000000000000 00000000E8030000 0000000000000000
0060  0000000000000000 0000000000000000 0000000000000000 0000000000000000
```

... The rest is omitted ...

## Property File

- PAGE\_CHECKSUM\_TYPE which is the one of the property is set by using gsql as follows.

```
gSQL> ALTER SYSTEM SET PAGE_CHECKSUM_TYPE = 1 SCOPE = BOTH;
System altered.
```

- The binary property file of GOLDILOCKS is dumped as follows.



```
$ gdump property goldilocks.properties.binary
```

```
=====
FILE: goldilocks.properties.binary
```

```
TYPE: PROPERTY-BINARY
```

```
TIME: 2014-08-29 12:45:13.853448
```

```
=====
PAGE_CHECKSUM_TYPE = 1
```

```
=====
TIME: 2014-08-29 12:45:13.853627
=====
```

## Commit Log

The commit log file is dumped as follows.

```
$ gdump commit_log commit.log
```

```
=====
FILE: commit.log
```

```
TYPE: COMMIT LOG FILE
```

```
TIME: 2017-03-23 11:47:42.555368
```

```
=====
[COMMIT LOG FILE HEADER]
```

```
-----
FILE_SEQUENCE   : 0
```

```
FILE_SIZE       : 104857600
```

```
MAX_BLOCK_COUNT : 204800
```

```
SIGNATURE       : 5DAABFECBDCD11E68785A3701A679D47
```

```
=====
[BLOCK(0), LOG_COUNT(1)]
```

```
TRANS_ID(1.0.59899956), COMMIT_SCN(16603.645.17371), INDOUBT_BEHAVIOR(FORGET),
```

```
SYNC_GLOBAL_TABLE_SCN(TRUE), PREV_LOG_FILE_SEQ(-1), PREV_LOG_BLOCK_SEQ(-1),
```

```
PREV_LOG_SLOT_SEQ(-1)
```

## Log Buffer File

The log buffer file created after executing gsyncher is dumped as follows.  
For more information, refer to **gsyncher**.

```
$ gdump log_buffer logbuffer.log
=====
FILE: logbuffer.log
TYPE: LOG BUFFER FILE
TIME: 2017-03-23 11:10:12.787400
=====
[LOG BUFFER FILE HEADER]
-----
REAR_FILE_BLOCK_SEQ_NO   : 203410
FRONT_FILE_BLOCK_SEQ_NO  : 203410
REAR_SBSN                 : 797213
REAR_LSN                  : 375933
REAR_LID                  : (3, 3254496, 161)
FRONT_SBSN                : 797212
FRONT_LSN                 : 375933
FILE_SEQ_NO               : 3
BUFFER_SIZE               : 10485760
BUFFER_BLOCK_COUNT       : 20480
BLOCK_OFFSET              : 13
GROUP_COMMIT_LSN         : 336688
LOG_SWITCHING_SBSN       : -1
=====
```

## Pending Log Buffer File

The pending log buffer file created after executing gsyncher is dumped as follows.  
For more information, refer to **gsyncher**.

```
$ gdump pend_buffer pendbuffer.log
=====
FILE: pendbuffer.log
TYPE: PEND BUFFER FILE
TIME: 2017-03-23 11:10:29.603646
```

```
=====
[PEND LOG BUFFER FILE HEADER]
```

```
PEND_LOG_BUFFER COUNT : 4
```

```
-----
PEND_LOG_BUFFER NO. : 0
```

```
PEND_BUFFER_SIZE : 1048576
```

```
BUFFER_BLOCK_COUNT : 16384
```

```
FRONT_PBSN : 102
```

```
REAR_PBSN : 102
```

```
FRONT_LSN : -1
```

```
REAR_LSN : 327055
```

```
-----
PEND_LOG_BUFFER NO. : 1
```

```
PEND_BUFFER_SIZE : 1048576
```

```
BUFFER_BLOCK_COUNT : 16384
```

```
FRONT_PBSN : 0
```

```
REAR_PBSN : 0
```

```
FRONT_LSN : -1
```

```
REAR_LSN : -1
```

```
-----
PEND_LOG_BUFFER NO. : 2
```

```
PEND_BUFFER_SIZE : 1048576
```

```
BUFFER_BLOCK_COUNT : 16384
```

```
FRONT_PBSN : 0
```

```
REAR_PBSN : 0
```

```
FRONT_LSN : -1
```

```
REAR_LSN : -1
```

```
-----
PEND_LOG_BUFFER NO. : 3
```

```
PEND_BUFFER_SIZE : 1048576
```

```
BUFFER_BLOCK_COUNT : 16384
```

```
FRONT_PBSN : 0
```

```
REAR_PBSN : 0
```

```
FRONT_LSN : -1
```

```
REAR_LSN : -1
```

```
=====
```



**42.**

---

**tablediff**

## 42.1 Overview of tablediff

### Background

The GOLDILOCKS system operator should prepare for the unexpected failure of GOLDILOCKS synchronization of two tables using the tools such as cyclone or LogMirror. An unexpected failure of synchronization refers that a particular row exists only in one table or the column values of rows to be synchronized are different from each other. Cyclone and LogMirror do not notify a user whether synchronization is failed. It is required to verify the synchronization of the table and to perform synchronization, if necessary, at non-operation time.

### Features

tablediff is a tool comparing two tables of GOLDILOCKS which was synchronized by using CDC in a row unit. It reports when a particular row exists only in a table or values are different each other, then performs synchronization. The configuration file for controlling various operations is input, and the log files to report the unsynchronized rows and the synchronization results are output.

The constraints are that the schemas of two tables should be same and each of them should have the primary key. It is not recommended to perform the tool for table of the currently executing transaction because the table can be updated in real time. However, it does not matter for the currently executing queryin g (SELECT statement). This tool is available only for the GOLDILOCKS tables.

This tool has two executing commands, which are TableDiff and TableSync.

### TableDiff

```
java sunje.goldilocks.tool.diff.TableDiff [configure file]
```

TableDiff program verifies whether two tables are unsynchronized, and it may output the information(binary file) to perform synchronization for unsynchronized rows immediately or at a later time according to a n option. The immediate synchronization can be operated for multiple threads.

### TableSync

```
java sunje.goldilocks.tool.diff.TableSync [configure file]
```

Tablesync program performs synchronization by using the sync information which was previously left by TableDiff. (Row comparison is not performed.) A simultaneous execution can be performed by driving multi threads.



Unsynchronized rows of two tables to which the configure file is not applied are stored in a bin file left by TableDiff. TableSync uses this bin file to forcibly synchronize two tables.

## Characteristics

This tool is a java application and it is provided in a jar file form, so Java(1.6) is required to execute the tool. Also, goldilocks6.jar is required because GOLDDILOCKS JDBC driver is used. It can be remotely performed because it is connected to GOLDDILOCKS by using TCP/ IP, and it is performed at much faster rate than using JDBC, ODBC with the proprietary protocol.

The row comparison and synchronization can be simultaneously performed with multi threads. For multithreading of the row comparison, equal dividing of the range of the key in the table should be manually performed. When the user splits the key range into ten ranges (The user can specify it in the configuration file), then ten threads compare the tables. On the other hand, the synchronization operation is performed by threads of as many as it is specified.

## File Configuration

tablediff program consists of a single file called as `$(GOLDDILOCKS_HOME)/bin/tablediff.jar`. `$(GOLDDILOCKS_HOME)/lib/goldilocks6.jar` file is also required for execution. Also, the configuration file is required as an input argument, and refer to the sample file, `$(GOLDDILOCKS_HOME)/conf/tablediff.conf`.

## 42.2 Usage

### Command Usage

Java (JRE 1.6 or JDK1.6) is required because tablediff is a java program. For this, tablediff.jar and goldilocks6.jar files should be included in CLASSPATH, or they should be specified with -classpath option of java. tablediff is executed as follows.

```
export
CLASSPATH=$CLASSPATH:$GOLDILOCKS_HOME/bin/tablediff.jar:$GOLDILOCKS_HOME/lib/goldilocks6.jar
java sunje.goldilocks.tool.diff.TableDiff [configure file]
```

Or

```
java -classpath $GOLDILOCKS_HOME/bin/tablediff.jar:$GOLDILOCKS_HOME/lib/goldilocks6.jar
sunje.goldilocks.tool.diff.TableDiff [configure file]
```

The result of executing TableDiff for the simple sample table is as follows.

```
gSQL> create table tab1 ( c1 integer primary key, c2 char(10) );
gSQL> create table tab2 ( c1 integer primary key, c2 char(10) );
gSQL> insert into tab1 values ( 1, 'HELLO');
gSQL> insert into tab2 values ( 1, 'HELLO');
gSQL> insert into tab1 values ( 2, 'WORLD');
gSQL> insert into tab2 values ( 2, 'world');
gSQL> insert into tab1 values ( 3, 'good');
gSQL> insert into tab2 values ( 4, 'good');
gSQL> commit;
shell> java sunje.goldilocks.tool.diff.TableDiff tablediff.conf
Total 4 rows processed
  > row diff          : 1, update target(success/failure): 1/0
  > key diff source only: 1, insert into target(success/failure): 1/0
  > key diff target only: 1, delete from target(success/failure): 1/0
TableDiff completed
elapsed time = 0.229 sec
```

- The contents of tablediff.conf



```
SOURCE_URL      = jdbc:goldilocks://127.0.0.1:22581/test
SOURCE_USER     = TEST
SOURCE_PASSWORD = test
SOURCE_SCHEMA   = PUBLIC
SOURCE_TABLE    = TAB1
TARGET_URL      = jdbc:goldilocks://127.0.0.1:22581/test
TARGET_USER     = TEST
TARGET_PASSWORD = test
TARGET_SCHEMA   = PUBLIC
TARGET_TABLE    = TAB2
OPERATION       = SYNC
TARGET_INSERT   = ON
TARGET_UPDATE   = ON
TARGET_DELETE   = ON
SOURCE_INSERT   = OFF
```

## Property Option

This chapter describes the available property options in the configuration file of tablediff.

### Property Options for SOURCE, TARGET Tables

These property options should necessarily be specified and they define the source and target tables. The source and target refer to table to be compared each.

- SOURCE\_URL: It is JDBC connection URL of GOLDDILOCKS in which the source table exists.
- SOURCE\_USER: It is the user account of GOLDDILOCKS in which the source table exists.
- SOURCE\_PASSWORD: It is the password of GOLDDILOCKS in which the source table exists.
- SOURCE\_SCHEMA: It is the schema of source table.
- SOURCE\_TABLE: It is the name of source table.
- TARGET\_URL: It is JDBC connection URL of GOLDDILOCKS in which the target table exists.
- TARGET\_USER: It is the user account of GOLDDILOCKS in which the target table exists.
- TARGET\_PASSWORD: It is the password of GOLDDILOCKS in which the target table exists.
- TARGET\_SCHEMA: It is the schema of target table.
- TARGET\_TABLE: It is the name of target table.

The following is an example.

```
SOURCE_URL      = jdbc:goldilocks://192.168.0.100:22581/test
SOURCE_USER     = TEST
SOURCE_PASSWORD = test
SOURCE_SCHEMA   = PUBLIC
SOURCE_TABLE    = T1
TARGET_URL      = jdbc:goldilocks://192.168.0.101:22581/test
TARGET_USER     = TEST
TARGET_PASSWORD = test
TARGET_SCHEMA   = PUBLIC
TARGET_TABLE    = T2
```

## Operation

It determines the operations of TableDiff. The DIFF property verifies only the synchronization integrity and reports it, but the SYNC property verifies the integrity and simultaneously performs synchronization.

The integrity result file (whose file name is specified as DIFF\_BIN\_FILE property) is generated when operating with DIFF and it is used to execute TableSync.

## Synchronization Policy

Four properties are used for controlling the synchronization policy and all of them have the value of either ON or OFF.

- TARGET\_INSERT: If the key in the source does not exist in the target, it inserts the key into the target.
- TARGET\_UPDATE: If the value of the column which is not a key is different, it updates the target row.
- TARGET\_DELETE: If the key does not exist in the source but exists in the target, it deletes the target row.
- SOURCE\_INSERT: If the key does not exist in the source but exists in the target, it inserts that row into the source.



Both TARGET\_DELETE and SOURCE\_INSERT are not allowed to be ON together.

## EXCLUDED\_COLUMNS

It specifies the columns to be excluded from the comparison. The comma (,) is used as a delimiter and the column name should be specified. The key columns can not be excluded.

## WHERE\_CLAUSE

It sets the conditions for comparing rows in the table. For example, the condition, `WHERE_CLAUSE = SALARY >= 1000000`, refers that the integrity is verified only for the rows having the values of their column salary equal to or bigger than 1,000,000.

## DISPLAY\_ROW\_UNIT

TableDiff program displays the progress status of table comparison, and it outputs to the console the number of rows processed each time whenever it processes a certain number of rows. The property sets the number of rows to be output. the default value is 100,000, and it can be omitted.

## SYNC\_OUT\_FILE

It specifies the name of the file in which the synchronization result is to be recorded. If not specified, the result is recorded in `tablesnc.log`. If multiple synchronized threads exist, a number is added at the end of the file name.

## DIFF\_OUT\_FILE

It specifies the name of the file in which the row mismatch result is to be recorded. If not specified, the result is recorded in `tablesnc.log`. This file is in a text form which is human-readable.

## DIFF\_BIN\_FILE

If the operation property is set to DIFF, TableDiff records the synchronization information in a file with a name specified by this property. This file is used as an input argument by TableSync.

## PROPAGATE\_REDO\_LOG

It determines whether to propagate the row synchronization log to another replicated server. The default value is OFF.

## LOGGING\_ON\_SUCCESS

It sets whether to record logs even when DML (INSERT, UPDATE, DELETE) used for the row synchronization is successful. The default value is OFF. If it is OFF, then the synchronization performance becomes poor. If DML is failed, the logging information is recorded regardless of this property.

## LOGGING\_ON\_DIFF

It sets whether to record logs when the mismatch occurs during comparing the row integrity. The default value is OFF.

## JOB\_QUEUE\_SIZE

The row synchronization is performed by the operating thread. The threads perform the synchronization by getting the operation from the JOB QUEUE one by one. The main thread of TableDiff or TableSync inserts the operation to JOB QUEUE. JOB QUEUE becomes full if the thread slowly performs synchronization. JOB\_QUEUE\_SIZE property sets the size of JOB QUEUE. If this value is big, JOB QUEUE never becomes full but it wastes a lot of memory. The default value is 100, and 100 is big enough to use without filling of the queue.

The property is recommended not to change unless it is needed.

## JOB\_THREAD

It sets the number of threads for synchronization. If not set, the default value is 1. If there are multiple rows to be synchronized, the value should be set considering the number of CPU. The bigger the value, the faster the synchronization is performed.

## JOB\_UNIT\_SIZE

The synchronization is performed in batch as much as the size specified by the property. The default value is 100.

## DISPLAY\_CALL\_STACK

It sets whether to display call stack when an error occurs. The default value is OFF.

## Replication Settings for Table Comparison

The row comparison of TableDiff is performed by a single thread by default. But multiple threads can perform comparisons by specifying the condition clause. The property name is PARTITION\_RANGE[n], and if the range for N properties is set such as the WHERE clause, n threads perform the comparison each.

For example, the following properties are specified for each of 12 threads to perform the comparison when the table includes the monthly data.

```
PARTITION_RANGE1 = MONTH=1
```

```
PARTITION_RANGE2 = MONTH=2
```

```
PARTITION_RANGE3 = MONTH=3  
PARTITION_RANGE4 = MONTH=4  
PARTITION_RANGE5 = MONTH=5  
PARTITION_RANGE6 = MONTH=6  
PARTITION_RANGE7 = MONTH=7  
PARTITION_RANGE8 = MONTH=8  
PARTITION_RANGE9 = MONTH=9  
PARTITION_RANGE10 = MONTH=10  
PARTITION_RANGE11 = MONTH=11  
PARTITION_RANGE12 = MONTH=12
```

All conditions should be disjointed, and the union of all conditions should be as same as the total set. Also, the column used in the condition should be the front part of the primary key. (It means that the specified condition should be able to use the primary index.)

This property is applied only to TableDiff, and TableSync ignores this property.



**43.**

---

**gsyncher**

## 43.1 Overview of gsyncher

### Definition

gsyncher is a utility provided by GOLDILOCKS, and which synchronizes the log of shared memory and the logfile of disk.

When the server is abnormally terminated, gsyncher synchronizes the latest log of shared memory and the logfile, then records it.

### Features

- gsyncher can not be executed during the server operation.
- The STARTUP stage of the server in which gsyncher can be executed is OPEN phase.
- When executing gsyncher, all other applications of the shared memory should be terminated.
- During gsyncher execution, the logfile can be switched and in this case, the controlfile is generated.
- gsyncher backups the controlfile and logfile in which the logs are reflected, in advance.
- gsyncher can be executed after restoring the damaged controlfile.

### Usage

```
gsyncher [options]
```

### Options

-l --log	Log trace msg
-s --silent	Do not print message
-f --home	home directory
-c --copy-right	Do not print copy right
-b --backup-path	Backup directory
-h --help	Print help message



## 43.2 Examples

- Example 1: gsyncher is executed during the server is normally operating.

```
$ gsyncher -l
[SHARED MEM] Attached to shm - Name(_STATIC), Key(21128)
[SHARED MEM] Detached from shm.
ERR-HY000(53002): gmaster is active
```

- Example 2: The server is not on the STARTUP stage on which gsyncher can be executed.

```
$ gsyncher -l
[SHARED MEM] Attached to shm - Name(_STATIC), Key(21128)
[SHARED MEM] Detached from shm.
ERR-HY000(53000): invalid phase(MOUNT): executable phase is OPEN
```

- Example 3: When executing gsyncher, the progress is displayed. The execution result is total buffer (0 ) bytes, and all logs are flushed to the logfile, so there is not a log to be synchronized.

```
$ gsyncher --log
[SHARED MEM] Attached to shm - Name(_STATIC), Key(21128)
[CLEAR PROCESS] Process 'gbalancer' is cleared.
[CLEAR PROCESS] Process 'gdispatcher' is cleared.
[CLEAR PROCESS] Process 'gdispatcher' is cleared.
[CLEAR PROCESS] Process 'gserver' is cleared.
[CLEAR PROCESS] Process 'gserver' is cleared.
[CLEAR PROCESS] Process 'gserver' is cleared.
[CLEAR PROCESS] Process 'gserver' is cleared.
[CLEAR PROCESS] Process 'gserver' is cleared.
[CLEAR PROCESS] Process 'gserver' is cleared.
[CLEAR PROCESS] Process 'gserver' is cleared.
[CLEAR PROCESS] Process 'gserver' is cleared.
[CLEAR PROCESS] Process 'gserver' is cleared.
[CLEAR PROCESS] Process 'gserver' is cleared.
[FLUSH] Log buffer flushed - Log group from id (0) to (0), lsn from (130784) to (130784),
total buffer (0) bytes
[SHARED MEM] Detached from shm.
[FINI] Log sync complete.
```

- gsyncher operations are recorded in logfile by using --log option.

```

$ cat $GOLDILOCKS_DATA/trc/gsyncher.trc
=====
gsyncher start
TIME      : 2015-08-05 16:12:15.776633
=====
[2015-08-05 16:12:15.776763 THREAD(29199,139846497756928)]
[INIT] Log started.
[2015-08-05 16:12:15.777113 THREAD(29199,139846497756928)]
[SHARED MEM] Attached to shm - Name(_STATIC), Key(21128)
[2015-08-05 16:12:15.777208 THREAD(29199,139846497756928)]
[CLEAR PROCESS] Process 'gbalancer' is cleared.
[2015-08-05 16:12:15.777297 THREAD(29199,139846497756928)]
[CLEAR PROCESS] Process 'gdispatcher' is cleared.
[2015-08-05 16:12:15.777358 THREAD(29199,139846497756928)]
[CLEAR PROCESS] Process 'gdispatcher' is cleared.
[2015-08-05 16:12:15.777416 THREAD(29199,139846497756928)]
[CLEAR PROCESS] Process 'gserver' is cleared.
[2015-08-05 16:12:15.777917 THREAD(29199,139846497756928)]
[CLEAR PROCESS] Process 'gserver' is cleared.
[2015-08-05 16:12:15.777993 THREAD(29199,139846497756928)]
[CLEAR PROCESS] Process 'gserver' is cleared.
[2015-08-05 16:12:15.778051 THREAD(29199,139846497756928)]
[CLEAR PROCESS] Process 'gserver' is cleared.
[2015-08-05 16:12:15.778107 THREAD(29199,139846497756928)]
[CLEAR PROCESS] Process 'gserver' is cleared.
[2015-08-05 16:12:15.778577 THREAD(29199,139846497756928)]
[CLEAR PROCESS] Process 'gserver' is cleared.
[2015-08-05 16:12:15.778652 THREAD(29199,139846497756928)]
[CLEAR PROCESS] Process 'gserver' is cleared.
[2015-08-05 16:12:15.778710 THREAD(29199,139846497756928)]
[CLEAR PROCESS] Process 'gserver' is cleared.
[2015-08-05 16:12:15.778766 THREAD(29199,139846497756928)]
[CLEAR PROCESS] Process 'gserver' is cleared.
[2015-08-05 16:12:15.778822 THREAD(29199,139846497756928)]
[CLEAR PROCESS] Process 'gserver' is cleared.
[2015-08-05 16:12:15.818007 THREAD(29199,139846497756928)]
[SHARED MEM] Detached from shm.
[2015-08-05 16:12:15.818100 THREAD(29199,139846497756928)]
[FINI] Log sync complete.

```

- Example 4: The logs from lsn 130786 to lsn 131012 are flushed to the log group 1.



[FLUSH] Log buffer flushed - Log group from id (2) to (3), lsn from (156412) to (178129), total buffer (16644096) bytes

[CONTROLFILE] Saving controlfile caused by logfile switching.

[CONTROLFILE] '/media/solid/ssd\_home/work/product/Gliese/home/wal/control\_0.ctl' control file is saved.

[CONTROLFILE] '/media/solid/ssd\_home/work/product/Gliese/home/wal/control\_1.ctl' control file is saved.

[SHARED MEM] Detached from shm.

[FINI] Log sync complete.

**44.**

---

**gmon**

## 44.1 Overview of gmon

### Definition

gmon is a database (gmaster) process monitoring utility provided by GOLDILOCKS.

### Features

gmon monitors whether database process (gmaster) is operated, and when the process is abnormally terminated, not by user's SHUTDOWN, then it executes **gsyncher** and terminates the process. It intends to reduce the loss of logs by executing gsyncher.

gmon can be set to be automatically operated by setting the server property GMON\_AUTOSTART to 1, or a user can directly executes gmon.



A single gmaster process can monitor only one gmon process.

### Usage

```
gmon [options]
```

### Options

```
-s --start      Start gmon
-t --stop      Stop gmon
-u --status     Get gmon status
-o --home      gmaster home path
-d --uds_dir   unix domain socket directory
-l --silent     Suppress display message
-r --no-copyright Suppress display copy right and version
-h --help      Print help messages
```

## start

It starts gmon.

## stop

It stops gmon.

## status

It checks the status of gmon process.

## home

It is the database home directory. If it is omitted, then it uses the value set in GOLDILOCKS\_DATA environment variable.

## uds\_dir

It sets the directory in which unix domain socket is created. The maximum length of the directory is 50 bytes. The default value is /tmp.

## silent

It does not output the result message.

## no-copyright

It does not output copyright and version.

## help

It outputs the help message.

## 44.2 Examples

- Example 1: Execute gmon by using the default path (\$GOLDILOCKS\_DATA).

```
$ gmon --start  
gmon is started.
```

- Example 2: Execute gmon by specifying home path. When a relative path is used, home path is specified based on \$GOLDILOCKS\_DATA.

```
$ gmon --start --home g1n1_home  
gmon is started.
```

- Example 3: Execute gmon by specifying home path as an absolute path. When an absolute path is used, the specified path is specified as a home path.

```
$ gmon --start --home /g1n1_home  
gmon is started.
```

- Example 4: Check the status of gmon process.

```
$ gmon --status --home /g1n1_home  
gmon is running(19119).
```

- Example 5: Terminate the gmon process.

```
$ gmon --stop --home /g1n1_home  
gmon is stopped.
```



**45.**

---

**gtrclogger**

## 45.1 Overview of gtrclogger

### Definition

gtrclogger is a utility remotely collecting logs of GOLDILOCKS.

GOLDILOCKS basically records events and trace logs which occur in a server, in system.trc file of the specified directory of SYSTEM\_LOGGER\_DIR of property. (The default value is \$GOLDILOCKS\_DATA/trc)

If multiple different instances are being operated, trace logs occur in each server should be separately monitored. For that, gtrclogger makes trace logs of each different GOLDILOCKS instances to be collected in a single spot. gtrclogger receives trace logs of various GOLDILOCKS being operated in a different device with udp, and stores them in a file.

gtrclogger receives trace logs from the remote GOLDILOCKS and records them in a file. For that, the remote GOLDILOCKS should have the following transfer properties.

- TRACE\_LOGGER
- TRACE\_LOGGER\_REMOTE\_HOST
- TRACE\_LOGGER\_REMOTE\_PORT

### Features

- gtrclogger can be operated regardless of server operation.
- Even when it receives trace logs from various servers, it sequentially stores them in a file.
- A trace log is basically stored as \$(GOLDILOCKS\_DATA)/trc/system.rmt.trc.
- If system.rmt.trc is bigger than 10M bytes , it is backedup as system.rmt.trc\_date\_Index.

### Usage

```
| gtrclogger [options]
```

## Options

```
-s --start      start gtrclogger
-q --stop      stop gtrclogger
-p --port      udp port for receive log (1024 ~ 49151): default 21470
-d --dir       write file directory: default $(GOLDILOCKS_DATA)/system.rmt.trc
-h --help      show gtrclogger help messages
```

## 45.2 Examples

- Example 1: Execute gtrclogger by using the default port (21470) and the default directory(\$GOLDILOCKS\_DATA/trc).

```
$ gtrclogger --start  
gtrclogger is started successfully.
```

- Example 2: Receive a trace log with two ports (21471, 21472) and set the directory as \$GOLDILOCKS\_DATA/rmt\_trc, then execute gtrclogger.

```
$ gtrclogger -s -p 21471 -p 21472 -d $GOLDILOCKS_HOME/rmt_trc  
ERR-HY000(11040): No such object  
(/home/lym1/workspace/product/Gliese/home/rmt_trc/system.rmt.trc)  
$ mkdir $GOLDILOCKS_HOME/rmt_trc  
$ gtrclogger -s -p 21471 -p 21472 -d $GOLDILOCKS_HOME/rmt_trc  
gtrclogger is started successfully.
```

- Example 3: Terminate gtrclogger.

```
$ gtrclogger -q  
Stop Done.
```

**46.**

---

**glocator**

## 46.1 Overview of glocator

### Definition

glocator is a utility which provides locations to a client and manages them in GOLDILOCKS cluster system. The location information of cluster member nodes is provided to the glocator program through **gloctl**. glocator communicates with the client and gloctl via UDP, and it communicates with gagent via TCP.



glocator requires the location information such as a listener host, listener port and db home path, and this information is provided to the glocator through gloctl.

### Usage

```
glocator [options]
```

### Options

#### help

#### Description

It outputs a help message.

#### Example

```
$ glocator --help
Usage:
  glocator [options]
Options:
  -c --create      Create glocator environment
  -s --start       Start glocator
  -t --stop        Stop glocator
  -f --conf        Set configure file
  -u --status      Get glocator status
  -l --silent      Suppress display message
```

```
-r --no-copyright Suppress display copy right and version  
-h --help          Print help message
```

## create

### Description

It creates the data file of glocator.

### Example

```
$ glocator --create  
glocator is created.
```



The data file of glocator is created in <GOLDILOCKS\_DATA>/db directory.

```
$ ls  
README glocator.dat system_data.dbf system_dict.dbf system_undo.dbf
```

## start

### Description

It starts glocator. If glocator having the same port already has started, then an error occurs.

### Example

```
$ glocator --start  
glocator is started.
```

## stop

### Description

It stops glocator which is in operation. The same port should be set to stop glocator in operation.

### Example

```
$ glocator --stop  
glocator is stopped.
```

## conf

### Description

It sets the configure file when starting glocator.

### Example

```
$ glocator --start --conf goldilocks.glocator.conf  
glocator is started.
```

## status

### Description

It outputs the status message of glocator which is in operation. The same port should be set to check the status of glocator in operation.

### Example

```
$ glocator --status  
Process ID: 26058  
Configuration file: goldilocks.glocator.conf  
Unix domain path: /tmp/unix-glocator.42581  
Udp listen host: 0.0.0.0, Port: 42581  
glocator is running.
```

## sync

### Description

It synchronizes the data of glocator set in ALTERNATE\_LOCATORS before driving glocator.

There are two methods for the data synchronization, which are SOURCE and BOTH. SOURCE method brings data from ALTERNATE\_LOCATORS, and BOTH method merges two glocators.

### Example

The following is an example of a successful use of the sync option with the SOURCE type.

```
$ glocator --start --sync SOURCE  
glocator is started.
```



The following is an example of failure of a sync option. The ALTERNATE\_LOCATORS property value is not set in the configure file.

```
$ glocator --start --sync SOURCE
ERR-HY000(60016): Need more alternate locator host information.
```

The following is an example of failure of a sync option. glocator set in ALTERNATE\_LOCATORS property does not response.

```
$ glocator --start --sync SOURCE
ERR-HY000(60016): Need more alternate locator host information.
```

The following is an example of a failure when no argument is provided for the sync option.

```
$ glocator --start --sync
ERR-HY000(11000): Invalid argument
```

## silent

### Description

It does not output the message of glocator about the execution.

### Example

```
$ glocator --start --silent
```

## no-copyright

### Description

It does not output the message of glocator's copyright and version about the execution.

### Example

```
$ glocator --start --no-copyright
glocator is started.
```

## 46.2 Using glocator

### Data File

glocator data file should be created before starting glocator.

```
$ glocator --create  
glocator is created.
```

The directory in which glocator data file is stored can be altered by editing configuration `LOCATION_FILE_DIR`. The default value is created in `<GOLDILOCKS_DATA>/db`. The data file can be altered by editing `LOCATION_FILE_NAME`. The default value is `glocator.dat`.

The maximum size and initial size of glocator data file can be altered by editing configuration `LOCATION_FILE_MAX_SIZE` and `LOCATION_FILE_SIZE`.

### CSTARTUP and CSHUTDOWN

glocator can be used to CSTARTUP and CSHUTDOWN the GOLDILOCKS server.

For that, glocator should be in operation, and CSTARTUP or CSHUTDOWN should be executed through `gsqlnet`.

However, `LOCATOR_DSN` and the property should be set in `odbc.ini` of the device which executes `gsqlnet`. For more information, refer to **GOLDILOCKS UNIX ODBC driver libraries**.

The following contents is set in `odbc.ini` to use glocator.

```
[GOLDILOCKS]  
HOST=127.0.0.1  
PORT=20101  
UID=sys  
PWD=gliese  
LOCATOR_DSN=GLOCATOR  
[GLOCATOR]  
HOST=127.0.0.1  
PORT=42581
```



If FILE property exists in DSN [GLOCATOR], then the file specified in FILE property takes precedence instead of using glocator. Therefore, FILE property should be excluded.

glocator should know the location information of member nodes to execute CSTARTUP and CSHUTDOWN.

## Replication

### Overview

glocator replication keeps data consistent, so it enables the stable service through the remote glocator when an error occurs.

### Configuration

Each glocator should set ALTERNATE\_LOCATORS property in a configure file to use the replication feature. Locator\_name should be set in ALTERNATE\_LOCATORS property and the specified Locator\_name should be set in a configure file together with HOST, PORT properties.

The following is how to set ALTERNATE\_LOCATORS property.

```
[LOCATOR]
ALTERNATE_LOCATORS = (locator_name1,locator_name2)
[locator_name1]
HOST= ip_address
PORT = port_num
[locator_name2]
HOST= ip_address
PORT = port_num
```

The following is an example of a configure file which sets ALTERNATE\_LOCATORS property.

```
[LOCATOR]
PORT=42581
SYNC_RESPONSE_TIMEOUT = 2
SYNC_RETRY_COUNT = 2
LOCATION_FILE_NAME='glocator_1.dat'
ALTERNATE_LOCATORS=(LOCATOR_2,LOCATOR_3)
[LOCATOR_2]
```

```
HOST=127.0.0.1
PORT=42582
[LOCATOR_3]
HOST=127.0.0.1
PORT=42583
```



- [LOCATOR] is DSN which is read as default by glocator.
- For more information about glocator-related ODBC and how to set gagent, refer to **odbc.ini File, ALTERNATE\_LOCATORS**.

## Synchronizing Data

The data should be consistent when the replicated glocator is in service. If glocator in operation does not exist, then all glocator can perform the normal start. If glocator in operation exists, an alternate glocator can be started by synchronizing the data using a **sync** option.

**sync** option has BOTH and SOURCE. BOTH merges glocator's own data and alternate glocator's data. SOURCE brings the data from the counterpart glocator. The sync operation of glocator is 1 : 1 correspondence task between a glocator and an alternate glocator. Therefore, if A and B are already being operated, and C is operated after syncing by using BOTH for the replication of three (A, B, C) glocators, then the data of A and B glocators may be different.

glocator in service synchronizes only the updated content. If the data synchronization fails due to the packet loss or other reasons, then the data may be different. In this case, update the data within that glocator by using **gloctl** program, or restart glocator with sync option.

## 46.3 Features of glocator

### Connection Service

It provides a service feature which enables arbitrarily access any node among user-defined nodes even though the location information of a specific node in a cluster environment is unknown.

The service feature is that a user specifies nodes managed by glocator an arbitrary group. This service can be registered by using gloctl program. Service lists managed by glocator can also be viewed by using gloctl program.

An application should be accessed by using ODBC driver, and LOCATOR\_DSN and LOCATOR\_SERVICE property should be specified in `odbc.ini` file.

Figure 1 locator\_service

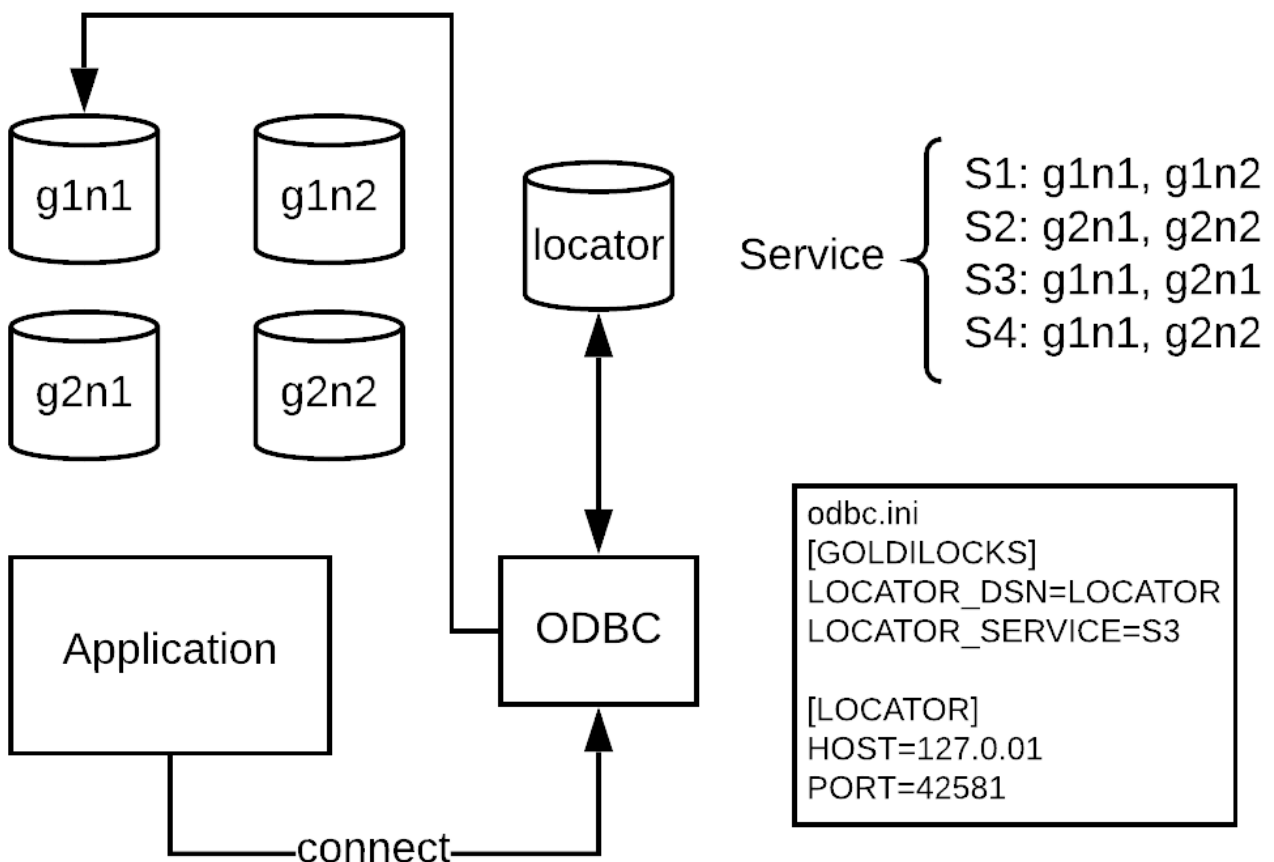

The figure above describes that an application accesses to g1n1 belonging to service s3. The connecting sequence of ODBC driver by using the service is as same as the sequence of node registered in the service. If ODBC driver fails to connect to g1n1 in the example above, it will try to connect to the next node g2n1.



To use the service feature, the valid location information of a node should be input in glocator in advance.

## Cluster Failover

glocator is helpful when a server proceeds the failover.

When the value of server property **CLUSTER\_SPLIT\_BRAIN\_RESOLUTION\_POLICY** is set to 1 or 2, and connection between nodes is disconnected in a cluster environment, a failover occurs, then each node proceeds the cluster failover and queries its viability to glocator through gagent.

The glocator which received a query determines the viability between two nodes which were disconnected, and transfer the result to the gagent which enquired the query.

Nodes received the viability results are terminated or proceeds the failover.



The cluster failover processing time of the server is relevant to various properties. Server property **LOCATOR\_QUERY\_TIMEOUT** sets the time waiting for the response after the server enquires to glocator, and the default value is 3 seconds.

Server property **CLUSTER\_SPLIT\_BRAIN\_RETRY\_COUNT** sets the number of enquiring again when glocator does not respond, and it is relevant to the cluster failover processing time. The default value is 1.

## 46.4 glocator Configuration

### Configuration File and Environment Variable

glocator can use a file or environment variable to set the configuration.

An environment variable can be set by using the name of which 'LOCATOR\_' is added as a prefix to a configuration property name. For example, setting HOST in the configuration file has the same effect as specifying \$LOCATOR\_HOST.

The contents of a configuration file takes precedence over the environment variable setting values.

glocator reads the configuration file by reading DSN as the default value of [LOCATOR].

glocator has \$GOLDILOCKS\_DATA/conf/goldilocks.glocator.conf file as its environment file. To alter the driving environment of glocator, the file contents should be altered, or glocator should start after setting the environment variables.

### Configuration Properties

#### HOST

Item	Description
Name	HOST
Description	It is an IP address of which glocator binds.
Data type	ip address (ip v4)
Default value/ range	0.0.0.0

It is an IP address of which glocator binds for UDP communication.

It uses an IP address in IP v4 form.

#### PORT

Item	Description
Name	PORT
Description	It is a port of which glocator waits for Recv.
Data type	INT
Default value/ range	42581 / 1024~49151

It is a port of which glocator receives a packet through UDP communication.  
The port from 1024 to 49151 can be used.

## WORKER\_COUNT

Item	Description
Name	WORKER_COUNT
Description	It is the number of threads processing a job.
Data type	INT
Default value/ range	1 / 1~8

It is the number of threads processing packets of which glocator received from a client or an internal process.

## MAX\_NODE\_COUNT

Item	Description
Name	MAX_NODE_COUNT
Description	It is the maximum number of connectable gagent.
Data type	INT
Default value/ range	64 / 1~8192

It is the maximum number of connectable gagent.

## MESSAGE\_QUEUE\_SIZE

Item	Description
Name	MESSAGE_QUEUE_SIZE
Description	It is the queue size in which received packets are stored before processing them.
Data type	INT
Default value/ range	33554432 / 10485760~2147483648

It is the size of queue of which glocator stores packets received from a client or or an internal process before processing them.

A packet is stored in a queue as a single item in message unit.



## MESSAGE\_ALLOCATOR\_SIZE

Item	Description
Name	MESSAGE_ALLOCATOR_SIZE
Description	It is the size of an allocator which allocates an item to be stored in a message queue.
Data type	INT
Default value/ range	33554432 / 10485760~2147483648

It is the size of an allocator which is used to allocate an item (message) to be stored in a message queue.

## PACKET\_ALLOCATOR\_SIZE

Item	Description
Name	PACKET_ALLOCATOR_SIZE
Description	It is the size of an allocator which allocates a packet when receiving packets through UDP communication.
Data type	INT
Default value/ range	33554432 / 10485760~2147483648

It is the size of an allocator for a buffer which is allocated for glocator to receive packets.

## SYSTEM\_LOGGER\_DIR

Item	Description
Name	SYSTEM_LOGGER_DIR
Description	It is the directory path of glocator trace log file.
Data type	String
Default value/ range	<GOLDILOCKS_DATA>/trc

It is the directory path in which system trace log file of glocator is stored. <GOLDILOCKS\_DATA> of the default value is replaced with the environment variable value of \$GOLDILOCKS\_DATA.

## SYSTEM\_UDS\_DIR

Item	Description
Name	SYSTEM_UDS_DIR
Description	It is the directory path in which unix domain socket file used in glocator is stored.
Data type	String
Default value/ range	/tmp (Maximum 60 byte)

It sets the directory path in which the unix domain socket file used in glocator is stored. The maximum length of the directory should be set within 60 bytes.

## LOCATION\_FILE\_DIR

Item	Description
Name	LOCATION_FILE_DIR
Description	It is the directory path in which the location file used in glocator is stored.
Data type	String
Default value/ range	<GOLDILOCKS_DATA>/db

It sets the directory path in which the location file used in glocator is stored.

## LOCATION\_FILE\_NAME

Item	Description
Name	LOCATION_FILE_NAME
Description	It is the name of a location file which is used in glocator.
Data type	String
Default value/ range	glocator.dat

It sets the name of a location file which is used in glocator.

The default value is glocator.dat.

## LOCATION\_FILE\_SIZE

Item	Description
Name	LOCATION_FILE_SIZE
Description	It is the initial size of a location file.
Data type	Int
Default value/ range	1048576 / 104576~2147483648

It sets the initial size of a location file used in glocator.

## LOCATION\_FILE\_MAX\_SIZE

Item	Description
Name	LOCATION_FILE_MAX_SIZE
Description	It is the maximum size of a location file.

Item	Description
Data type	Int
Default value/ range	10485760 / 104576~2147483648

It sets the maximum size of a location file used in glocator.

## MESSAGE\_TIMEOUT

Item	Description
Name	MESSAGE_TIMEOUT
Description	It sets the maximum time for glocator to wait to receive packets.
Data type	Int
Default value/ range	100 / 0 ~ 2147483648(단위 Second)

It sets the maximum time (seconds) for glocator to wait to receive packets. Packets exceeds the maximum time without being processed, are dumped.

## ALTERNATE\_LOCATORS

Item	Description
Name	ALTERNATE_LOCATORS
Description	It sets an alternate locator and replication of glocator.
Data type	String
Default value/ range	empty / 0 ~ 1024 bytes

It sets **Replication** of glocator.

## SYNC\_RETRY\_COUNT

Item	Description
Name	SYNC_RETRY_COUNT
Description	It sets the number of retry when glocator fails to synchronize with an alternate locator.
Data type	Int
Default value/ range	1 / 0 ~ 5

It sets the number of redelivery of glocator synchronization.

glocator transfers the altered data to alternate locator when the data is altered, and it transfers the data again when it could not get any response.

## SYNC\_RESPONSE\_TIMEOUT

Item	Description
Name	SYNC_RESPONSE_TIMEOUT
Description	It sets the time waits for the response for the synchronization of glocator.
Data type	Int
Default value/ range	5 / 1 ~ 20

It sets the time waits for the response for the synchronization data transferred from glocator.

## KEEPALIVE\_IDLE\_TIME

Item	Description
Name	KEEPALIVE_IDLE_TIME
Description	tcp keepalive idle time for checking dead client session (sec)
Data type	INT
Default value/ range	1 / 1 ~ 16383

It is the (idle) duration which the TCP packet is not sent nor is received before sending a keep alive packet. In other words, if TCP packet is not exchanged during the time set in KEEPALIVE\_IDLE\_TIME, then it performs the keep alive mechanism to detect the dead connection.

## KEEPALIVE\_COUNT

Item	Description
Name	KEEPALIVE_COUNT
Description	tcp keepalive check count
Data type	INT
Default value/ range	5 / 1 ~ 10

It is the number of performing keep alive mechanism.

## KEEPALIVE\_INTERVAL

Item	Description
Name	KEEPALIVE_INTERVAL
Description	tcp keepalive packet interval (sec)
Data type	INT
Default value/ range	5

It is the time interval to send the keep alive packet.



**47.**

---

**gagent**

## 47.1 Overview of gagent

### Definition

gagent is a utility communicating with **glocator** by being executed with each member node in GOLDILO CKS cluster system.

When **CLUSTER\_SPLIT\_BRAIN\_RESOLUTION\_POLICY** server property value of the node to which gagent belongs is set to 1 or 2, and the connection between nodes is disconnected so the cluster failover is proceeding, then gagent enquires to glocator the validity of the node to which the gagent belongs.

For more information, refer to **Cluster Failover**.

### Usage

```
gagent [options]
```

### Options

#### help

#### Description

It outputs the help message.

#### Example

```
$ gagent --help
Usage:
  gagent [options]
Options:
  -s --start           Start gagent
  -t --stop           Stop gagent
  -u --status         Get gagent status
  -f --conf           Set configure file
  -o --home           gmaster home path
  -l --silent         Suppress display message
```



<code>-r --no-copyright</code>	Suppress display copy right and version
<code>-h --help</code>	Print help message

## start

### Description

It starts gagent. If gagent having the same home directory already has been started, then an error occurs.

### Example

```
$ gagent --start  
gagent is started.
```

## stop

### Description

It stops gagent which is in operation. The same home directory should be set to stop gagent in operation.

### Example

```
$ gagent --stop  
gagent is stopped.
```

## status

### Description

It outputs the status message of gagent which is in operation. The same home directory should be set to check the status of gagent in operation.

### Example

```
$ gagent --status  
gagent(31938) is running.
```

## conf

### Description

It sets the configure file when starting gagent.

### Example

```
$ gagent --start --conf goldilocks.gagent.conf  
gagent is started.
```

## home

### Description

It sets the server home directory of GOLDILOCKS when starting gagent.

When a relative path is used, it searches for the home directory based on <GOLDILOCKS\_DATA>. <GOLDILOCKS\_DATA> is replaced with the environment variable value of \$GOLDILOCKS\_DATA.

### Example

```
$ gagent --start --home g1n1_home --conf goldilocks.gagent.conf  
gagent is started.
```

In the example above, gagent is started by setting <GOLDILOCKS\_DATA>/g1n1\_home to home.

## silent

### Description

It does not output the message of gagent about the execution.

### Example

```
$ gagent --start --silent
```

## no-copyright

## Description

It does not output the message of gagent's copyright and version about the execution.

## Example

```
$ gagent --start --no-copyright  
gagent is started.
```

## 47.2 gagent Configuration

### Configuration File and Environment Variable

gagent can use a file or environment variable to set the configuration.

An environment variable can be set by using the name of which 'AGENT\_' is added as a prefix to a configuration property name. For example, setting HOST in the configuration file has the same effect as specifying \$AGENT\_HOST.

The contents of a configuration file takes precedence over the environment variable setting values.

gagent has \$GOLDILOCKS\_DATA/conf/goldilocks.gagent.conf file as its environment file. To alter the driving environment of gagent, the file contents should be altered, or gagent should start after setting the environment variables.

### Configuration Properties

#### HOST

Item	Description
Name	HOST
Description	It is an IP address of which gagent binds.
Data type	ip address (ip v4)
Default value/ range	0.0.0.0

It is an IP address of which gagent binds for UDP communication.

It uses an IP address in IP v4 form.

#### REQUEST\_PORT

Item	Description
Name	REQUEST_PORT
Description	It is a port which gagent uses for request.
Data type	INT
Default value/ range	43581 / 1024~49151

It is a port of which gagent uses to request to glocator during tcp communication.  
The port from 1024 to 49151 can be used.

## RESPONSE\_PORT

Item	Description
Name	RESPONSE_PORT
Description	It is a port which gagent uses for response.
Data type	INT
Default value/ range	43582 / 1024~49151

It is a port of which gagent uses to receive the response from glocator during tcp communication.  
The port from 1024 to 49151 can be used.

## LOCATOR\_HOST

Item	Description
Name	LOCATOR_HOST
Description	It is an IP address of glocator.
Data type	ip address(ip v4)
Default value/ range	0.0.0.0

It is an IP address of glocator.

## LOCATOR\_PORT

Item	Description
Name	LOCATOR_PORT
Description	It is a port of which glocator waits for Recv.
Data type	INT
Default value/ range	42581 / 1024~49151

It is the port of glocator of when gagent sends packets to glocator.  
The port from 1024 to 49151 can be used.

## SYSTEM\_LOGGER\_DIR

Item	Description
Name	SYSTEM_LOGGER_DIR
Description	It is the directory path of gagent trace log file.
Data type	String
Default value/ range	<GOLDILOCKS_DATA>/trc

It is the directory path in which system trace log file of gagent is stored. <GOLDILOCKS\_DATA> of the default value is replaced with the environment variable value of \$GOLDILOCKS\_DATA.

## SYSTEM\_UDS\_DIR

Item	Description
Name	SYSTEM_UDS_DIR
Description	It is the directory path which stores Unix Domain Socket file of gagent.
Data type	String
Default value/ range	/tmp (Maximum 50 bytes)

It is the directory path which stores Unix Domain Socket file of gagent. The default value is /tmp. The directory length can be set up to 50 bytes.

## ALTERNATE\_LOCATORS

Item	Description
Name	ALTERNATE_LOCATORS
Description	It sets the alternate locators.
Data Type	String
Default value/ range	empty / 0 ~ 1024

If locator set in gagent does not respond, then it proceeds to process the operation by replacing with an alternate locator.

The following is an example of a configure file which used ALTERNATE\_LOCATOR.

```
[AGENT]
PORT=43581
LOCATOR_HOST=127.0.0.1
LOCATOR_PORT=42581
ALTERNATE_LOCATORS=(LOCATOR1,LOCATOR2)
[LOCATOR1]
```

```

HOST=127.0.0.1
PORT=42582
[LOCATOR2]
HOST=127.0.0.1
PORT=42583

```

## KEEPALIVE\_IDLE\_TIME

Item	Description
Name	KEEPALIVE_IDLE_TIME
Description	tcp keepalive idle time for checking dead client session (sec)
Data type	INT
Default value/ range	1 / 1 ~ 16383

It is the (idle) duration which the TCP packet is not sent nor is received before sending a keep alive packet. In other words, if TCP packet is not exchanged during the time set in KEEPALIVE\_IDLE\_TIME, then it performs the keep alive mechanism to detect the dead connection.

## KEEPALIVE\_COUNT

Item	Description
Name	KEEPALIVE_COUNT
Description	tcp keepalive check count
Data type	INT
Default value/ range	5 / 1 ~ 10

It is the number of performing keep alive mechanism.

## KEEPALIVE\_INTERVAL

Item	Description
Name	KEEPALIVE_INTERVAL
Description	tcp keepalive packet interval (sec)
Data type	INT
Default value/ range	5

It is the time interval to send the keep alive packet.





**48.**

---

**gloctl**

## 48.1 Overview of gloctl

### Definition

gloctl is an interactive utility provided by GOLDILOCKS, which provides location to **glocator** and edits it. gloctl communicates with glocator by using User Datagram Protocol (UDP) communication protocol.

### Usage

```
gloctl [options]
```

### Options

#### help

#### Description

It outputs the help message.

#### Example

```
$ gloctl --help
Usage:
  gloctl [options]
Options:
  -c --conf          User configure file
  -i --ip            Locator host ip
  -p --port          Locator port number
  -o --import        Import control FILE
  -l --silent        Suppress the display of result message and echoing commands
  -r --no-copyright Suppress display copy right and version
  -h --help          Print help message
```

## conf

### Description

It sets a **Configuration** file to communicate with glocator.  
If it is not set, \$GOLDILOCKS\_DATA/conf/goldilocks.gloctl.conf is used.

### Example

```
$ gloctl --conf gloctl.conf  
gLoctl>
```

- The contents of gloctl.conf file above is as follows.

```
[GLOCTL]  
# Port number (1024 ~ 49151)  
PORT = 44581  
# Locator address  
LOCATOR_HOST = 127.0.0.1  
# Locator port number (1024 ~ 49151)  
LOCATOR_PORT = 42581  
# Time out to receive message from glocator (second)  
# second ( 0 ~ 2147483647 )  
MESSAGE_TIMEOUT = 10
```

## ip

### Description

It sets IP address of glocator when starting gloctl. IP set value takes precedence when it is used together with DSN.

### Example

```
$ gloctl --ip 127.0.0.1  
gLoctl>
```

The port of glocator in the example above is obtained by using DSN default LOCATOR in odbc.ini.

## port

### Description

It sets the port of glocator when starting gloctl. The port set value takes precedence when it is used together with DSN.

### Example

```
$ gloctl --port 42581
gLoctl>
```

IP of glocator in the example above is obtained by using DSN default LOCATOR in odbc.ini.

## import

### Description

It performs gloctl commands in batch within a file, not an interactive mode.

### Example

```
$ gloctl --import import.txt
HELP
QUIT
IMPORT      {'FILE'}           Upload FILE to locations
EXPORT      {'FILE'}           Download locations to FILE
ADD MEMBER  {DSN}{member_name {'host; port; db_home;'}} Add member location
DROP MEMBER {member_name}     Drop member location
SET TIMEOUT {second}          Set time for session timeout
Add member succeeded.
```

- The contents of import.txt above is as follows.

```
HELP
ADD MEMBER G1N3 'HOST=127.0.0.1;PORT=24581;DB_HOME=g1n3_home;'
```

## silent

## Description

It does not output the message of gloctl about the execution.

## Example

```
$ gloctl --silent --import import.txt
```

## no-copyright

### Description

It does not output the message of gloctl's copyright and version about the execution.

### Example

```
$ gloctl --no-copyright  
gLoctl>
```

## 48.2 Interactive Command References

### ADD MEMBER

#### Syntax

```
ADD MEMBER {DSN | member_name {'host; port; db_home;'}}
```

#### Description

It adds a member to glocator. DSN existing in odbc.ini, a member name, and the required location information should be input.



- The port is that of glsnr.
- ADD MEMBER is used to update the information of an existing member. In this case, if the member is in the process of the failover, then the update fails.

#### Example

ADD MEMBER by using DSN of odbc.ini.

```
gLoctl> ADD MEMBER G1N1
Add member succeeded.
gLoctl>
```

- The contents of odbc.ini is as follows.

```
[G1N1]
HOST=127.0.0.1
PORT=20101
DB_HOME= g1n1_home
LOCATOR_DSN=LOCATOR
```

- Describe the location of a member, and add it.

```
gLoctl> ADD MEMBER G1N2 'HOST=127.0.0.1; PORT=20201; DB_HOME=g1n2_home;'
Add member succeeded.
gLoctl>
```

# ADD SERVICE

## Syntax

```
ADD SERVICE service_name {'member_name; ... '}
```

## Description

It adds a service to glocator. The node belonging to the service should be managed in **glocator**, and it is ignored when the same node does not exist in glocator.

## Example

Add the service *s1* by using ADD SERVICE.

```
gLoc1> ADD SERVICE S1 'G1N1;G1N2;G2N1'  
Add service succeeded.  
gLoc1>
```

- The contents of `odbc.ini` is as follows.

```
[GOLDILOCKS]  
HOST=127.0.0.1  
PORT=22581  
LOCATOR_DSN=LOCATOR  
LOCATOR_SERVICE=S1  
[LOCATOR]  
HOST=127.0.0.1  
PORT=42581
```



When describing glocator properties in **odbcinst.ini file** and using **glocator**, then **gsqlnet** and other applications can access one of a server from the service list.

# DROP MEMBER

## Syntax

```
DROP MEMBER member_name
```

## Description

It drops a member corresponding to member\_name from glocator.



If a member is in the process of the failover, then the member can not be dropped.

## Example

```
gLoctl> DROP MEMBER G1N2  
Drop member succeeded.  
gLoctl>
```

# DROP SERVICE

## Syntax

```
DROP MEMBER service_name
```

## Description

It drops a service corresponding to service\_name from glocator.

## Example

```
gLoctl> DROP SERVICE S1  
Drop service succeeded.  
gLoctl>
```



# EXPORT

## Syntax

```
EXPORT {'FILE'}
```

## Description

It receives the location information from glocator and stores it in a file.

## Example

Download the location information in Location.txt file.

```
gLoct1> EXPORT 'Location.txt'  
Export file succeeded.  
gLoct1>
```

- The contents of Location.txt above is as follows.

```
[G1N1]  
PORT = 20101  
HOST = 127.0.0.1  
DB_HOME = g1n1_home  
[G1N3]  
PORT = 24581  
HOST = 127.0.0.1  
DB_HOME = g1n3_home
```

## HELP

## Syntax

```
HELP
```

## Description

It displays the commands list in an interactive mode of gloctl.

## Example

```
gLoctl> HELP
HELP
QUIT
IMPORT {'FILE'} Upload FILE to locations
EXPORT {'FILE'} Download locations to FILE
ADD MEMBER {DSN|{member_name {'host; port; db_home;'}}} Add member location
DROP MEMBER {member_name} Drop member location
SET TIMEOUT {second} Set time for session timeout
ADD SERVICE {service_name {'member_name; ... '}} Add service
DROP SERVICE {service_name} Drop service
gLoctl>
```

## IMPORT

### Syntax

```
IMPORT {'FILE'}
```

### Description

It transfers the location to glocator by using a file in ini form.

### Example

It transfers the contents in Location.txt to glocator.

```
gLoctl> IMPORT 'Location.txt'
Import file succeeded.
gLoctl>
```

- The contents of Location.txt above is as follows.

```
[G1N1]
PORT = 20101
HOST = 127.0.0.1
DB_HOME = g1n1_home
[G1N3]
PORT = 24581
HOST = 127.0.0.1
DB_HOME = g1n3_home
```

## QUIT

### Description

It quits gloctl.

### Syntax

```
QUIT
```

## SET TIMEOUT

### Description

It sets TIMEOUT of glocator.

### Syntax

```
SET TIMEOUT {second}
```

### Example

```
gLoctl> set timeout 120
Set timeout.
gLoctl>
```

## 48.3 Location File

Location file uploads or downloads the location information of a node from gloctl to glocator.

### Description

Location file format is similar to that of **Data Source Specification** file.

```
[node_name]
HOST = host_address
PORT = port_no
DB_HOME = db_home_path
[SERVICE]
service_name = node_name {, node_name}*
```

Location keywords of Location file are as follows.

**Table 48-1** Location information

Keyword	Description
node_name	It is the name of a node.
HOST	It is the IP address of a node.
PORT	It is the port number of glsnr which was executed in a node.
DB_HOME	It sets the home directory of a node.

[SERVICE] is a fixed keyword which lists the service hints. Service hints which are registered or to be registered in glocator are listed below SERVICE keyword.

HOST and PORT keywords should be input, and an error occurs if they are omitted.

The following is an example of configuring a location file.

```
[G1N1]
HOST = 192.168.0.101
PORT = 20101
DB_HOME = g1n1_home
[G1N2]
HOST = 192.168.0.102
PORT = 20102
DB_HOME = g1n2_home
```

[G2N1]

HOST = 192.168.0.201

PORT = 20201

DB\_HOME = g2n1\_home

[G2N2]

HOST = 192.168.0.202

PORT = 20202

DB\_HOME = g2n2\_home

[SERVICE]

service\_1 = G1N1,G2N1

service\_2 = G1N1,G1N2

## 48.4 Configuration

The environment file of gloctl is `$GOLDILOCKS_DATA/conf/goldilocks.gloctl.conf`. The environment file should be altered or the environment file should be set with `conf` option and restart gloctl, to alter the driving environment for gloctl.

Stop gloctl and alter the driving environment, then restart it to alter the environment of gloctl and to apply it, while gloctl is being executed.

### PORT

Item	Description
Name	PORT
Description	It is a port which is used by gloctl.
Data type	INT
Default value/ range	44581 / 1024 ~ 49151

It sets the port of a socket which is used by gloctl.

### LOCATOR\_HOST

Item	Description
Name	PORT
Description	It is the host address of glocator with which gloctl communicates.
Data type	STRING
Default value/ range	127.0.0.1

It sets the host address of glocator.

### LOCATOR\_PORT

Item	Description
Name	PORT
Description	It is the port of glocator with which gloctl communicates.

Item	Description
Data type	INT
Default value/ range	42581 / 1024 ~ 49151

It sets the port of glocator.

## MESSAGE\_TIMEOUT

Item	Description
Name	MESSAGE_TIMEOUT
Description	It sets the time of which gloctl waits for the response from glocator. (second)
Data type	INT
Default value/ range	10 / 0 ~ 2147483647

It sets the time of which gloctl waits for the response after transferring a packet to glocator.





## **Part VII.**

---

# **Replication**

<b>49. Overview</b>	<b>4,193</b>
49.1 Overview of GOLDILOCKS Replication	4,194
49.2 Characteristics	4,195
CYCLONE	4,195
LOGMIRROR	4,195
CYFILE	4,195
<b>50. CYCLONE</b>	<b>4,197</b>
50.1 CYCLONE	4,198
Overview	4,198
Operational Features	4,198
Operational Restrictions	4,199
DDL Processing during Replication	4,200
Datatype Compatibility When Interworking with Other DBMS	4,201
Others	4,205
50.2 Requirements	4,206
GOLDILOCKS Requirements	4,206
Registering User and Setting Privileges	4,208
50.3 Configuration	4,210
Configuration File	4,210
Configuration Option	4,212
50.4 Operating	4,230
GOLDILOCKS Connection Policy	4,230
Executing Option	4,232
50.5 Operating Examples	4,236
Operating Order	4,236
Original GOLDILOCKS Configuration	4,237
Remote GOLDILOCKS Configuration	4,237
CYCLONE MASTER Configuration	4,237
CYCLONE SLAVE Configuration	4,238
Executing and Operating	4,238
Synchronizing Data	4,239
Initializing Replication Information	4,240
Recovery	4,241
50.6 Operating CYCLONE in Cluster	4,243
Requirements	4,243
Operating	4,243
Executing	4,245
SYNC Method	4,247
Others	4,247

50.7 Monitoring (CYMON)	4,248
Configuration File	4,248
Monitoring Contents	4,248
Executing and Monitoring	4,249
<b>51. LOGMIRROR</b>	<b>4,253</b>
51.1 LOGMIRROR	4,254
Overview	4,254
Operational Features	4,254
Performance Degradation Factors of GOLDILOCKS When Operating LOGMIRROR	4,254
51.2 Requirements	4,256
GOLDILOCKS Requirement	4,256
51.3 Configuration	4,258
Configuration File	4,258
Configuration Options	4,258
51.4 Operating	4,262
Operating LOGMIRROR	4,262
Executing Option	4,263
51.5 Examples of Interworking with CYCLONE	4,264
Operating Order	4,265
<b>52. CYFILE</b>	<b>4,271</b>
52.1 CYFILE	4,272
Overview	4,272
Operational Features	4,272
Operational Restrictions	4,272
Others	4,273
52.2 Requirements	4,274
GOLDILOCKS Requirements	4,274
Registering User and Setting Privileges	4,276
52.3 Configuration	4,277
Configuration File	4,277
Configuration Options	4,278
52.4 Operating	4,287
Executing Option	4,287
52.5 Files	4,290
Data File	4,290
Control File	4,295



**49.**

---

## **Overview**

## 49.1 Overview of GOLDILOCKS Replication

Database replication efficiently and consistently distributes data for data recovery when an error occurs in the original database by using the remote database, so that it enables sustained service. It is also used to build multiple database with same data.

GOLDILOCKS replication supports CYCLONE, which is a tool using Change Data Capture (CDC) method.



### Change Data Capture (CDC)

This method captures and analyzes the redo log generated during the database operation, and performs the replication.

Only the asynchronous mode is supported because CYCLONE is available after the changes of the database are stored in the redo log file.

The interval may occur between the original database and the remote database of the replication because CDC method supports only the asynchronous mode. When the failure of original database or equipment occurs in the state of which the replication to the remote database is not completed, the remote database is in the state of which the interval is not reflected.

LOGMIRROR can be used to complement the data not reflected due to the interval of the asynchronous mode.



LOGMIRROR is a tool which replicates the redo log files. It sends and stores the redo logs generated from the original database to the remote equipment without any loss of data. Therefore, using LOGMIRROR can prevent loss of data.

It provides CYFILE tool storing the transaction data which was processed and committed in the database in Comma-Separated Values (CSV) format file by using CDC method. A user can directly process the data by using the stored file or converts the data according to its purpose.



CYFILE directly captures the redo log file by using CDC method and analyzes the transaction in real time, then stores the contents in CSV format file.

## 49.2 Characteristics

### CYCLONE

The followings are the characteristics of CYCLONE.

- It is a replication tool which uses Change Data Capture (CDC) method.
- It recognizes, analyzes and applies the changes in redo log files of the original database.
- It is operated being divided into master and slave.
- It supports active-active, active-standby.
- Replication is available in table unit.
- Several options can be set to improve the performance.
- It does not affect GOLDILOCKS in case of failure because it is operated as an independent process.
- Adding or changing the H/W is not required for operation.
- It allows various replication topology
- The operation between master and slave in standalone environment supports the relationship of 1 : 1 or N : N.
- The operation between master and slave in cluster environment supports the relationship of N : 1.

### LOGMIRROR

The followings are the characteristics of LOGMIRROR.

- It transfers and stores the redo logs of the original database to the remote machine without any loss.
- It interworks with CYCLONE and replicates without any loss of data.
- Only one LOGMIRROR can be operated in a database.
- It is operated being divided into master and slave.

### CYFILE

The followings are features of CYFILE.

- It uses Change Data Capture (CDC) method.
- It recognizes and analyzes updates in the redo log file of the original database.
- It captures in the unit of table.
- The process is independently operated, so GOLDILOCKS is not affected even when an error occurs.

- It supports standalone environment and cluster environment.



**50.**

---

**CYCLONE**

## 50.1 CYCLONE

CYCLONE is a replication tool which uses the Change Data Capture (CDC) method.

### Overview

Database records the data changes which occur during the operation in the redo log file for the recovery. CDC performs the replication by analyzing the information of the recorded redo log file.

CYCLONE is driven being divided into master and slave. Master recognizes the changes of the redo log file in the original database and analyzes it, then transfers it to the slave. Slave analyzes the received data and performs the replication by using ODBC.

### Operational Features

- It is divided into master and slave and is operated as master/slave in group unit.
- Master and slave of CYCLONE uses TCP/ IP communication.
- It can be executed/ terminated in group unit.
- The replication is executed in table unit, and a group may include one or more tables.
- A single table may be operated being included in several groups.
- The original database should have the redo log files, so DATA\_STORE\_MODE should be operated in TDS.
- The original database should have SUPPLEMENTAL LOGGING.
  - SUPPLEMENTAL LOGGING adds an additional information to the redo log files for the replication of CYCLONE.
- The original database should be operated in ARCHIVE LOG mode.
  - GOLDILOCKS recursively reuses the redo log files. When the redo log files are reused before the replication is completed, the replication becomes aborted and the existing replication from the current point is canceled then restarted. Therefore, the redo log files should be operated in ARCHIVE LOG mode to be archived.
- It does not affect GOLDILOCKS even when it fails to replicate because it is operated as an independent process.

## Operational Restrictions

- The table participated in the replication should have a PRIMARY KEY.
- Only the committed transaction is allowed to be replicated. Therefore, the content is unknown to the slave before committing the transaction.
- The primary key update is not supported.
  - When the primary key is updated, the table is given up and it is not replicated any more.
- The table participated in the replication can not use the column which has Generated Always As Identity property.
- When Data Definition Language (DDL) is performed on the table in which the replication is being operated, it could be given up.
  - For more information, refer to **The occurrence of give up and whether to allow DDL statement according to DDL category** in table1.
  - If it does not comply with the processing procedure of table DDL of CYCLONE, then even the allowable DDL is given up.
  - It does not affect the replication of other tables.
  - It is same in case of the truncated table.
- The given-up table can be reset only when it was given up with --reset TABLE\_NAME
- The columns configuring the table participating in the replication should have the same structure. (data type, order)
- The database performing the replication should have the same character encoding.
- The table stored in the recycle bin is not a replication target.

**Table 50-1** The occurrence of give up and whether to allow DDL statement according to DDL category

DDL category	Occurrence of give up	Whether to allow DDL statement	DDL statement
Table DDL	X	-	CREATE TABLE
	O	X	DROP TABLE
	O	X	TRUNCATE TABLE
	O	X	ALTER TABLE .. RENAME
	X	-	ALTER TABLE .. STORAGE
	X	-	ALTER TABLE .. ADD SUPPLEMENTAL LOG
	O	X	ALTER TABLE .. DROP SUPPLEMENTAL LOG
Column DDL	X	-	ALTER TABLE .. READ { ONLY   WRITE }
	O	O	ALTER TABLE .. ADD COLUMN
	O	X	ALTER TABLE .. SET UNUSED COLUMN
	O	-	ALTER TABLE .. RENAME COLUMN
	X	-	ALTER TABLE .. ALTER COLUMN .. SET DEFAULT
	X	-	ALTER TABLE .. ALTER COLUMN .. DROP DEFAULT
O	X	ALTER TABLE .. ALTER COLUMN .. SET NOT NULL	

DDL category	Occurrence of give up	Whether to allow DDL statement	DDL statement
	O	X	ALTER TABLE .. ALTER COLUMN .. DROP NOT NULL
	O	X	ALTER TABLE .. ALTER COLUMN .. ALTER IDENTITY
	O	X	ALTER TABLE .. ALTER COLUMN .. DROP IDENTITY
	O	O	ALTER TABLE .. ALTER COLUMN .. SET DATATYPE
Constraint DDL	O	X	ALTER TABLE .. ADD CONSTRAINT
	O	X	ALTER TABLE .. DROP CONSTRAINT
	O	X	ALTER TABLE .. ALTER CONSTRAINT
	X	-	ALTER TABLE .. RENAME CONSTRAINT
Index DDL	O	X	CREATE UNIQUE INDEX
	X	-	CREATE INDEX
	O	X	DROP INDEX unique_index
	X	-	DROP INDEX non_unique_index
	X	-	ALTER INDEX .. STORAGE
	X	-	ALTER INDEX .. RENAME
Superordinate object of table	O	X	DROP USER
	O	X	DROP SCHEMA
	O	X	DROP TABLESPACE



The server property **DISABLE\_DDL\_CDC\_GIVEUP** can disable the DDL statement which causes the replication give up to avoid user created errors. Also, the server property **DISABLE\_UPDATE\_PRIMARY\_KEY\_CDC\_GIVEUP** can disable primary key update.

## DDL Processing during Replication

It should comply with the following procedure when the allowable DDL is performed for the table in which the replication is being performed.

1. Terminate all operating CYCLONE in master and slave before executing DDL in master.
  - The process in progress does not need to be terminated.
  - e.g. cyclone --master --stop / cyclone --slave --stop
2. Execute DDL in both master and slave. (It should be the allowable DDL.)
  - For more information, refer to **Table 50-1 The occurrence of give up and whether to allow DDL statement according to DDL category**.
3. Restart CYCLONE of master and slave.
  - cyclone --master --start ... / cyclone --slave --start ...

- It does not require --reset option.
- It performs the recovery from the termination of the first stage and process DDL when restarting. (Refer to trace log)

**Table 50-2** DDL application procedure

Item	MASTER CYCLONE	MASTER DB	SLAVE CYCLONE	SLAVE DB
1	CYCLONE STOP	-	-	-
2	-	-	CYCLONE STOP	-
3	-	Executing DDL	-	-
4	-	-	-	Executing DDL
5	CYCLONE START	-	-	-
6	-	-	CYCLONE START	-



If the table which executed DDL in CYCLONE master is given up after DDL application procedure is normally performed, then the following two should be checked.

1. Check if DDL performed in the master DB and in the slave DB is same, and check if the table structure is same after performing the DDL. (The order of performing DDL does not matter.)
2. Check if the performed DDL is allowable.

If the table is given up due to the reasons above, the given-up table should be replicated again from the current point by using reset in table unit and restarting it. (e.g. cyclone --start --master -reset TABLE\_NAME).

## Datatype Compatibility When Interworking with Other DBMS

- When target database of CYCLONE slave interworks with other DBMS instead of GOLDILOCKS, the column datatype of GOLDILOCKS table, source database, should be compatible with that of other DBMS table so that it can prevent the data loss or an error.
- Currently, it can interwork with Oracle, MySQL and DB2.
- When interworking with other DBMS, then SYNC and allowable DDL features are not available.

### Oracle

**Table 50-3** Datatype compatible with Oracle

GOLDILOCKS	Oracle	Remarks
Boolean	X	The corresponding datatype does not exist.
NATIVE_SMALLINT	NUMBER(5)	-
NATIVE_INTEGER	NUMBER(10)	-
NATIVE_BIGINT	NUMBER(19)	-
NATIVE_REAL	BINARY_FLOAT	-
NATIVE_DOUBLE	BINARY_DOUBLE	-
FLOAT	FLOAT	-
SMALLINT	NUMBER(5,0)	-
INTEGER	NUMBER(10,0)	-
BIGINT	NUMBER(19,0)	-
INT2	NUMBER(5,0)	-
INT4	NUMBER(10,0)	-
INT8	NUMBER(19,0)	-
REAL	FLOAT(24)	-
DOUBLE	FLOAT(53)	-
DOUBLE PRECISION	FLOAT(53)	-
FLOAT4	FLOAT(24)	-
FLOAT8	FLOAT(53)	-
DECIMAL	NUMERIC	-
NUMBER	NUMBER	-
NUMERIC	NUMERIC	-
CHAR	CHAR	-
VARCHAR	VARCHAR, VARCHAR2	-
BINARY	RAW	-
VARBINARY	RAW	-
DATE	DATE	-
TIME	X	The corresponding datatype does not exist.
TIMESTAMP	TIMESTAMP	-
TIMESTAMP WITH TIMEZONE	X	It does not support ODBC driver.
INTERVAL	X	It does not support ODBC driver.
LONG VARCHAR	LONG VARCHAR	-
LONG VARBINARY	LONG RAW	-

- The following four datatypes can not be replicated as described in a table above.
  - BOOLEAN
  - TIME
  - TIMESTAMP WITH TIMEZONE

- INTERVAL

## MySQL

**Table 50-4** Datatype compatible with MySQL

GOLDBLOCKS	MySQL	Remarks
Boolean	BOOL, BOOLEAN	The corresponding type in MySQL is a synonym of TINYINT(1).
NATIVE_SMALLINT	SMALLINT	-
NATIVE_INTEGER	INT	-
NATIVE_BIGINT	BIGINT	-
NATIVE_REAL	FLOAT	-
NATIVE_DOUBLE	DOUBLE	The corresponding type in MySQL is a synonym of DOUBLE PRECISION, and it does not support the unsigned.
FLOAT	X	The precision is supported up to 53 in MySQL, and a data error occurs if the precision is bigger.
SMALLINT	SMALLINT	-
INTEGER	INTEGER	-
BIGINT	BIGINT	-
INT2	SMALLINT	-
INT4	INTEGER	-
INT8	BIGINT	-
REAL	REAL	-
DOUBLE	DOUBLE	-
DOUBLE PRECISION	DOUBLE PRECISION	-
FLOAT4	FLOAT(24)	A data error may occur.
FLOAT8	FLOAT(53)	A data error may occur.
DECIMAL	DECIMAL	-
NUMBER	X	-
NUMERIC	NUMERIC	-
CHAR	TEXT	-
VARCHAR	TEXT	-
BINARY	VARBINARY	-
VARBINARY	VARBINARY	-
DATE	DATETIME	-
TIME	TIME(6)	The data is not lost when fractional seconds precision is set.
TIMESTAMP	DATETIME(6)	The data is not lost when fractional seconds precision is set.

GOLDILOCKS	MySQL	Remarks
TIMESTAMP WITH TIMEZONE	X	It does not support ODBC driver.
INTERVAL	X	It does not support ODBC driver.
LONG VARCHAR	TEXT	-
LONG VARBINARY	BLOB	-

- The following four datatypes can not be replicated as described in a table above.
  - FLOAT
  - NUMBER
  - TIMESTAMP WITH TIMEZONE
  - INTERVAL



When 'lower\_case\_table\_names' is set to '0' in Mysql settings, then it is case sensitive in schema/ table name. Therefore, use a double quotation (") in schema/ table name when specifying the configuration file.

## DB2

**Table 50-5** Datatype compatible with DB2

GOLDILOCKS	DB2	비고
Boolean	X	The corresponding datatype does not exist.
NATIVE_SMALLINT	SMALLINT	-
NATIVE_INTEGER	INT	-
NATIVE_BIGINT	BIGINT	-
NATIVE_REAL	REAL	-
NATIVE_DOUBLE	DOUBLE	-
FLOAT	DOUBLE	-
SMALLINT	DECIMAL(5)	-
INTEGER	DECIMAL(10)	-
BIGINT	DECIMAL(19)	-
INT2	DECIMAL(5)	-
INT4	DECIMAL(10)	-
INT8	DECIMAL(19)	-
REAL	DOUBLE	-
DOUBLE	DOUBLE	-
DOUBLE PRECISION	DOUBLE	-
FLOAT4	DOUBLE	-
FLOAT8	DOUBLE	-



GOLDSLOCKS	DB2	비고
DECIMAL	DECIMAL	The significant digit of DB2 is 31.
NUMBER	DECIMAL	The significant digit of DB2 is 31.
NUMERIC	DECIMAL	The significant digit of DB2 is 31.
CHAR	CHAR	The maximum size of DB2 is 254 bytes.
VARCHAR	VARCHAR	-
BINARY	CHAR(n) FOR BIT DATA	The maximum size of DB2 is 254 bytes.
VARBINARY	VARCHAR(n) FOR BIT DATA	-
DATE	DATE / TIMESTAMP(0)	DATE of DB2 is stored only in YYYY/MM/DD format.
TIME	X	-
TIMESTAMP	TIMESTAMP	-
TIMESTAMP WITH TIMEZONE	X	It does not support ODBC driver.
INTERVAL	X	It does not support ODBC driver.
LONG VARCHAR	CLOB	-
LONG VARBINARY	BLOB	-

## Others

The replication moments are as follows.

- At the first run, the replication starts after master and slave are performed and the initialization is terminated.
- Even if it is restarted after terminated during the replication, the replication is continuously performed from the termination point. (Recovery feature)
- It should be restarted by using --reset option when giving up the existing replication and restarting from the current point.

## 50.2 Requirements

Original GOLDILOCKS: It is required to perform GOLDILOCKS preparations, user registration and privilege setting all.

Remote GOLDILOCKS: It is required to perform user registration and privilege setting only.

### GOLDILOCKS Requirements

The followings should be set in GOLDILOCKS before starting the replication using CYCLONE.

#### SUPPLEMENTAL LOGGING

SUPPLEMENTAL LOGGING stores additional information in the redo log file for the replication of CYCLONE. The database restart is required to change the settings of the database in operation, but the database restart is not required to set SUPPLEMENTAL LOGGING for a particular table.

#### Setting SUPPLEMENTAL LOGGING in Database

- If the GOLDILOCKS property is set as SUPPLEMENTAL LOGGING, SUPPLEMENTAL LOGGING is recorded for every table.
- GOLDILOCKS restart is required.
- The appropriate information is added or updated in the property file.
  - Property file: goldilocks.properties.conf
  - Property setting: SUPPLEMENTAL LOG\_DATA\_PRIMARY\_KEY = YES

#### Setting SUPPLEMENTAL LOGGING in Specific Table Participating in Replication

```
<add table supplemental log statement> ::=
ALTER TABLE table_name
    ADD SUPPLEMENTAL LOG DATA ( PRIMARY KEY ) COLUMNS
;
```

#### ARCHIVE LOG

GOLDILOCKS reuses the redo log files recursively. When GOLDILOCKS reuses the redo log file being processed by CYCLONE, then CYCLONE does not proceed and is terminated. GOLDILOCKS should be operated in ARCHIVE LOG mode to ensure the continuous replication operation.

## Changing Database in Operation to ARCHIVE LOG Mode

- Restart GOLDILOCKS.
- After database is shutdown, connect with sysdba and change it to ARCHIVE LOG mode in MOUNT phase.

```
gSQL> \startup mount
Startup success
gSQL> alter database archivelog;
Database altered.
```

## Setting ARCHIVE LOG Mode When Creating Database

- Update the property file before creating the database.
  - Property file: goldilocks.properties.conf
  - Property setting: ARCHIVELOG\_MODE = 1



The path in which ARCHIVE LOG file is stored can be viewed and updated with 'ARCHIVELOG\_DIR'.

## DATA\_STORE\_MODE

CYCLONE performs the replication by reading the redo log files of GOLDILOCKS. Therefore, GOLDILOCKS should be operated in Transactional Data Store (TDS) mode.

## Changing DATA\_STORE\_MODE

- Restart the database.
- Add or update the corresponding information in the property file.
  - Property file: goldilocks.properties.conf
  - Property setting: DATA\_STORE\_MODE = 2



If the value of DATA\_STORE\_MODE is 1, it indicates Concurrent Data Store (CDS), and if it is 2, it indicates Transactional Data Store (TDS).

## Registering User and Setting Privileges

CYCLONE retrieves and manipulates the required information during the operation. The user operating CYCLONE and the proper privileges for the user are required.

### Creating Database User

A specific user should be added to operate CYCLONE, and the corresponding user should be added for all GOLDILOCKS of which CYCLONE is operated in master, slave mode.

```

<user definition> ::=
    CREATE USER user_identifier IDENTIFIED BY password
    [ DEFAULT TABLESPACE tablespace_name ]
    [ TEMPORARY TABLESPACE tablespace_name ]
    [ INDEX TABLESPACE {tablespace_name|NULL} ]
    [ <schema clause> ]
    ;
<schema clause> ::=
    WITH SCHEMA [schema_name]
    | WITHOUT SCHEMA
  
```

The following is an example of creating the user `cdc_user` with the password `cdc_password`.

```
gSQL> CREATE USER cdc_user IDENTIFIED BY cdc_password;
```

## Database Privileges

### Granting User Access Privilege

The following is an example for granting the access privilege to `cdc_user`. It should be set on all GOLDILOCKS which is operated in both master/ slave mode.

```
gSQL> GRANT CREATE SESSION ON DATABASE TO cdc_user;
```

### Granting Privilege for Altering Table

The following is an example of granting the table updating privilege to `cdc_user`. It is set on GOLDILOCKS which is operated in slave mode.

```
gSQL> GRANT INSERT ANY TABLE, DELETE ANY TABLE, UPDATE ANY TABLE ON  
DATABASE TO cdc_user;
```

## Tablespace Privileges

The privileges on the data tablespace and temporary tablespace should be set. The following is an example of granting the privilege for using the default tablespace to cdc\_user. It is set on GOLDILOCKS which is operated in slave mode.

```
gSQL> GRANT CREATE OBJECT ON TABLESPACE mem_data_tbs TO cdc_user;  
gSQL> GRANT CREATE OBJECT ON TABLESPACE mem_temp_tbs TO cdc_user;
```

## Schema Privileges

The schema privileges for creating and managing meta managed in CYCLONE should be set. The following is an example granting the schema privilege to cdc\_user. It is set on GOLDILOCKS which is operated in slave mode.

```
gSQL> GRANT CREATE TABLE, CREATE INDEX, CREATE SEQUENCE, CREATE VIEW,  
ADD CONSTRAINT ON SCHEMA cdc_user TO cdc_user;
```

## 50.3 Configuration

### Configuration File

When performing CYCLONE, the information and options required for operating are set by using the configuration file.

- When a specific configuration file is not set by using the --conf option, a specific file in the \$GOLDLOCKS\_DATA/conf directory is read. cyclone.master.conf file is read when it is operated in master mode and cyclone.slave.conf file is read when it is operated in slave mode.

**Table 50-6** Configuration file options

Name	Description	Coverage
COMM_CHUNK_COUNT	It sets the size of BUFFER for communication.	Master/ slave
DSN	It sets Data Source Name.	Master/ slave
GROUP_NAME	It sets the group name.	Master/ slave
HOST_IP	It sets the host IP address of which GOLDLOCKS operates.	Master/ slave
HOST_EXTERNAL_IP	It is used when slave GOLDLOCKS IP to which the cyclone master is to be connected is different from HOST_IP. (When master and slave are on wan section.)	Slave
HOST_PORT	It sets the host port of which GOLDLOCKS operates.	Master/ slave
PORT	It sets the port for master/ slave communication.	Master/ slave
USER_ID	It sets the user name.	Master/ slave
USER_PW	It sets the user password.	Master/ slave
USER_ENCRYPT_PW	It sets the encrypted password for DB user.	Master/ slave
CAPTURE_TABLE	It sets the table to be replicated.	Master
LOG_PATH	It is used when interworking with LOGMIRROR and it sets the location of the redo log file.	Master
PROTOCOL	It sets the connection type which is to be connected to GOLDLOCKS. (DA or TCP)	Master/ slave
READ_LOG_BLOCK_COUNT	It sets the amount of data to be read at a time when operating CAPTURE.	Master
TRANS_SORT_AREA_SIZE	It sets the size of the BUFFER to be allocated to CAPTURE.	Master
TRANS_FILE_PATH	It sets the location in which the temporarily generated file is to be stored when operating CAPTURE.	Master
SYNCHER_COUNT	It is applied when using SYNC feature, and it sets the number of SYNCHERs simultaneously performing the data insertion.	Master

Name	Description	Coverage
SYNC_ARRAY_SIZE	It is applied when using SYNC feature, and it sets the array size which insert data at a time.	Master
GIVEUP_INTERVAL	If the replication performance speed is lower than GOLDILOCKS performance, it is set to stop the replication.	Master
APPLIER_COUNT	It sets the number of APPLIER simultaneously performed during the replication.	Slave
APPLY_COMMIT_SIZE	It sets the maximum size for COMMIT during the replication.	Slave
APPLY_TABLE	It sets the table to which the replicated table is to be applied.	Slave
MASTER_IP	It sets the IP address of the equipment of which CYCLONE master is operated.	Slave
PROPAGATE_MODE	It sets whether to propagate the data applied by CYCLONE.	Slave
UPDATE_APPLY_MODE	It distinguishes the operation when updating. (The default value is 0.) <ul style="list-style-type: none"> <li>0: It is updated only when the primary keys are same.</li> <li>1: It is updated only when the primary key and the value before the update are same.</li> <li>2: It is updated only when the primary keys are same. It compares the value before and after the update, then leaves a log if the values are different.</li> </ul>	Slave
TCP_NODELAY	It sets TCP_NODELAY option of a socket. (The default value is 1.) <ul style="list-style-type: none"> <li>0: TCP_NODELAY off</li> <li>1: TCP_NODELAY on</li> </ul>	Master
HEARTBEAT_TIMEOUT	It sets the maximum time (second) maintaining connection if the connection is not smooth due to network disconnection or system error after replication connection.	Master/ slave
SKIP_COMMENT	It enters the text for transaction skip. If the same text is entered as commit comment in master, then it skips that transaction instead of replicating it.	Master
LOG_CAPTURE_INTERVAL_1	It sets the execution cycle of capture. If the value is not changed after executing 10 times with that value, then it is converted to the value of LOG_CAPTURE_INTERVAL_2 and performs capture. (The default value is 0.2 seconds.)	Master
LOG_CAPTURE_INTERVAL_2	It sets the execution cycle of capture. If the value is not changed after executing with the value of LOG_CAPTURE_INTERVAL_1, then it sets the execution cycle of capture. (The default value is 1 second.)	Master
CLUSTER	It specifies the connection information of a master when the master is in cluster environment. A master consists of the following three information. <ul style="list-style-type: none"> <li>ID: It is a delimiter and sets to 1 or more value.</li> <li>MASTER_IP</li> <li>PORT</li> </ul>	Slave
ORACLE_DRIVER	It specifies the file location of the Oracle ODBC driver provided by Oracle.	Slave
MYSQL_DRIVER	It specifies the file location of the MySQL ODBC driver provided by MySQL.	Slave
MYSQL_DATABA		

Name	Description	Coverage
SE	It specifies the database name of MySQL to replicate.	Slave
PACKET_COMPRESSION_MODE	It sets whether to compress the data of communication of master and slave. (1: Enable, 0: Disable, Default: Enable)	Master
DB2_DRIVER	It specifies the file location of DB2 ODBC driver provided by DB2	Slave
DB2_DATABASE	It specifies the DB2 database name to replicate.	Slave

## Configuration Option

### COMM\_CHUNK\_COUNT

- It sets the number of buffers(chunk) used in data communication between master and slave of CYCLONE.
- It allocates the resource with  $16M * N$  (the set value).
- The default value is 32, and the actual size is  $16M * 32 = 512 M$ .
- The minimum value is 10.
- It can be set in master and slave.
  - If too small value is set so the buffer is not enough, the performance becomes poor.
- Settings applied to all groups

```
COMM_CHUNK_COUNT = 10
```

- Settings applied to a specific group

```
GROUP_NAME = testGROUP
{
    COMM_CHUNK_COUNT=20
    ....
    ....
}
```

### DSN

- It sets the data source name which is required when connecting to GOLDILOCKS.
- It can be set in master and slave.
- The default value is GOLDILOCKS.
- Settings applied to all groups



```
DSN=GOLDILOCKS
```

- Settings applied to a specific group

```
GROUP_NAME = testGROUP
{
    DSN=GOLDILOCKS
    ....
    ....
}
```

## GROUP\_NAME

- It is necessary for distinguishing the CYCLONE operation within the equipment and it is a unit of generating the operation process.
- It is the delimiter of when starting or terminating CYCLONE in group unit.
- After it is set, it should not be changed. If changed, it is regarded as a new group.
- It can be set in master and slave.
  - The connection between master and slave is separated not by GROUP\_NAME but by PORT.
  - GROUP\_NAME should be unique in the same equipment.
- The braces { } should be used.

```
GROUP_NAME = testGROUP
{
    ....
    ....
}
```

## HOST\_IP

- It sets the IP address of GOLDILOCKS to be connected by CYCLONE.
- It can be set in master and slave.
  - It is valid only when PROTOCOL is set to TCP.
- Settings applied to all groups

```
HOST_IP = 127.0.0.1
```

- Settings applied to a specific group

```
GROUP_NAME = testGROUP
{
  HOST_IP = 127.0.0.1
  ....
  ....
}
```

## HOST\_EXTERNAL\_IP

- It can be set in slave.
- CYCLONE master access GOLDDILOCKS of the slave's side when it is operated in sync, and it is used if slave GOLDDILOCKS IP to which the cyclone master is to be connected is different from HOST\_IP.
  - It is used when IP on lan and IP on wan is different because master and slave are on wan section.
  - CYCLONE slave transfers this value to CYCLONE master, and it is used in CYCLONE master.
- Settings applied to all groups

```
HOST_EXTERNAL_IP = 192.168.0.120
```

- Settings applied to a specific group

```
GROUP_NAME = testGROUP
{
  HOST_EXTERNAL_IP = 192.168.0.120
  ....
  ....
}
```

## HOST\_PORT

- It sets the port of GOLDDILOCKS to be connected by CYCLONE.
- It should be set together with HOST\_IP.
- It can be set in master and slave.
- Settings applied to all groups

```
HOST_PORT = 22531
```

- Settings applied to a specific group

```
GROUP_NAME = testGROUP
{
  HOST_PORT = 22531
  ....
  ....
}
```

## PORT

- It sets the PORT used in the communication between master and slave.
- The duplicated PORT should not be set between the groups, and the unique value should be used for each GROUP.
- It is mandatory be set and it can be set only within GROUP\_NAME.
- It can be set only within a group.

```
GROUP_NAME = testGROUP
{
  PORT = 21102
  ....
  ....
}
```

## USER\_ID

- It sets the user ID required to access GOLDDLOCKS.
- It can be set in master and slave.
- Settings applied to all groups

```
USER_ID = testID
```

- Settings applied to a specific group

```
GROUP_NAME = testGROUP
{
  USER_ID = testID
  ....
  ....
}
```

## USER\_PW

- It sets the user password required to access GOLDILOCKS.
- It can be set in master and slave.
- Settings applied to all groups

```
USER_PW = testPW
```

- Settings applied to a specific group

```
GROUP_NAME = testGROUP
{
    USER_PW = testPW
    ....
    ....
}
```

## USER\_ENCRYPT\_PW

- It sets the user password which is required for the access to GOLDILOCKS by encrypting.
- It is used instead of USER\_PW.
- Encrypted user password is created by [cyclone --encrypt *user password* --key *the key to be encrypted* ].
- If this value is used, then --key option should be used when executing cyclone. (In this case, the key value as same as that created with --encrypt should be used.
- Settings applied to all groups

```
USER_ENCRYPT_PW = 't33KImiqvhqNyfN+uZmFrw=='
```

- Settings applied to a specific group

```
GROUP_NAME = testGROUP
{
    USER_ENCRYPT_PW = 't33KImiqvhqNyfN+uZmFrw=='
    ....
    ....
}
```

## CAPTURE\_TABLE

- It sets the table to be replicated.
  - It is set in *schema\_name.table\_name* format.
- It can set only in master.
- It can be set only within a group.
- When specifying several tables, the parentheses ( ) should be used.
- The table stored in the recycle bin can not be set to be replicated.

```
GROUP_NAME = testGROUP
{
    CAPTURE_TABLE =
    (
        testSchema1.testTable1,
        testSchema1.testTable2,
        testSchema2.testTable1
    )
}
```

## LOG\_PATH

- It is used when interworking with LOG MIRROR.
- It sets the path of the redo log files stored by LOGMIRROR.
  - The absolute path should be used.
  - The path should be specified by using single quote (').
- Settings applied to all groups

```
LOG_PATH = '/data/wal/'
```

- Settings applied to a specific group

```
GROUP_NAME = testGROUP
{
    LOG_PATH = '/data/wal/'
    ....
    ....
}
```

## PROTOCOL

- It sets the type to connect to GOLDDILOCKS in operation.
  - It can be set to DA or TCP.
  - If PROTOCOL is set to DA, neither HOST\_IP nor is HOST\_PORT used when accessing to GOLDDILOCKS.
    - However, in a slave, HOST\_IP and HOST\_PORT can be used for SYNC even when PROTOCOL is DA.
  - The default value is DA.
- Settings applied to all groups

```
PROTOCOL = DA
```

- Settings applied to a specific group

```
GROUP_NAME = testGROUP
{
    PROTOCOL = DA
    ....
    ....
}
```

## READ\_LOG\_BLOCK\_COUNT

- It sets the number of the log blocks to be read at a time when capturing redo log file.
  - It can be set only in master.
  - The size of a log block is 512 bytes.
  - The default value is 40960, and the actual read size is 20 MBytes.
    - The minimum value is 100.
- Settings applied to all groups

```
READ_LOG_BLOCK_COUNT = 1024
```

- Settings applied to a specific group

```
GROUP_NAME = testGROUP
{
    READ_LOG_BLOCK_COUNT = 1024
    ....
    ....
}
```

## TRANS\_SORT\_AREA\_SIZE

- It sets the memory space required for capturing the redo log files.
- It can be set only in master.
- The unit is MB (megabytes).
- The default value is 500 MB.
  - The minimum value is 10 MB.
- If the value is set too small, the performance becomes poor.
- Settings applied to all groups

```
TRANS_SORT_AREA_SIZE = 300
```

- Settings applied to a specific group

```
GROUP_NAME = testGROUP
{
  TRANS_SORT_AREA_SIZE = 300
  ....
  ....
}
```

## TRANS\_FILE\_PATH

- If a space bigger than TRANS\_SORT\_AREA\_SIZE is required, the temporary file is created. It sets the path in which the temporary file is to be stored.
  - The absolute path should be used.
  - The path should be specified by using single quote (').
- It can be set only in master.
- Settings applied to all groups

```
TRANS_FILE_PATH = '/data/TmpTrans'
```

- Settings applied to a specific group

```
GROUP_NAME = testGROUP
{
  TRANS_FILE_PATH = '/data/TmpTrans'
  ....
  ....
}
```

## SYNCHER\_COUNT

- It is used for synchronization.
  - It sets the number of SYNCHERs participating in synchronization.
  - It is input in the number unit.
- It is set only in master.
- Settings applied to all groups

```
SYNCHER_COUNT = 8
```

- Settings applied to a specific group

```
GROUP_NAME = testGROUP
{
    SYNCHER_COUNT = 8
    ....
    ....
}
```

## SYNC\_ARRAY\_SIZE

- It is used for synchronization.
  - It sets the unit of record to be inserted at a time when performing synchronization.
  - It is input in the number unit.
- It can be set only in master.
- Settings applied to all groups

```
SYNC_ARRAY_SIZE = 1000
```

- Settings applied to a specific group

```
GROUP_NAME = testGROUP
{
    SYNC_ARRAY_SIZE = 1000
    ....
    ....
}
```



## GIVEUP\_INTERVAL

- It gives up the replication and terminates CYCLONE if the INTERVAL between GOLDLOCKS and CYCLONE is bigger than the set value.
  - It is input in the number of REDO LOG BLOCK unit.
- It can be set only in master.
- Settings applied to all groups

```
GIVEUP_INTERVAL = 10000
```

- Settings applied to a specific group

```
GROUP_NAME = testGROUP
{
    GIVEUP_INTERVAL = 10000
    ....
    ....
}
```

## APPLIER\_COUNT

- It sets the number of APPLIER executing replication.
  - It indicates a parallel factor.
- The default value is 6, and 6 sessions are created.
  - The maximum value is not limited, but too high value can cause the contention between APPLIERS.
  - The set value significantly affects on performance.
  - The session is created according to the set value and the replication is simultaneously performed.
- It can be set only in slave.
- Settings applied to all groups

```
APPLIER_COUNT = 16
```

- Settings applied to a specific group

```
GROUP_NAME = testGROUP
{
    APPLIER_COUNT = 16
    ....
    ....
}
```

```
}

```

## APPLY\_COMMIT\_COUNT

- It sets the number of transaction executing COMMIT when the replication is performed.
  - It executes COMMIT after performing the transaction once when replicating transactions committed in the original database to the remote database.
  - The set value indicates the maximum value.
- The set value affects on performance.
- It can be set only in slave.
- Settings applied to all groups

```
APPLY_COMMIT_COUNT = 1000

```

- Settings applied to a specific group

```
GROUP_NAME = testGROUP
{
    APPLY_COMMIT_COUNT = 1000
    ....
    ....
}

```

## APPLY\_TABLE

- It sets the table to which the replicated table is to be applied.
  - It is set in *replicating table name TO table name to which the replicated table is applied* format.
  - The table names are not necessary to be same.
- It can be set only in slave.
- It can be set only within a group.
- The parentheses ( ) should be used when specifying several tables.

```
GROUP_NAME = testGROUP
{
    APPLY_TABLE =
    (
        testSchema1.testTable1 TO testSchema1.testTable1,
        testSchema1.testTable2 TO testSchema2.testTable3,
        testSchema2.testTable3 TO testSchema2.testTable4
    )
}

```

```
}

```

## MASTER\_IP

- It sets the IP address of the device which CYCLONE master operates.
- It can be set only in slave.
- Settings applied to all groups

```
MASTER_IP = 192.168.0.100

```

- Settings applied to a specific group

```
GROUP_NAME = testGROUP
{
    MASTER_IP = 192.168.0.100
    ....
    ....
}

```

## PROPAGATE\_MODE

- If CYCLONE is circularly configured, it sets whether or not another CYCLONE applies the transactions of which a CYCLONE applied.
- It can be set only in slave.
  - The default value is '0' and it does not PROPAGATE.
  - If it is set to 1, it is PROPAGATED. If it is set to 0, it is not PROPAGATED.
- Settings applied to all groups

```
PROPAGATE_MODE = 1

```

- Settings applied to a specific group

```
GROUP_NAME = testGROUP
{
    PROPAGATE_MODE = 1
    ....
    ....
}

```

## UPDATE\_APPLY\_MODE

- It is used for the update operation in slave.
  - 0: If only the primary keys are same, the update operation is performed. (The default value)
  - 1: If the primary key is same with the value of before updating, the update operation is performed.
  - 2: If only the primary keys are same, the update operation is performed. The values before and after updating are compared and if they are different, then it leaves the logs.
- If it is set to 0, the previous value is not checked and the update is performed.
- If it is set to 1 and the previous value is different, the update is failed and leaves the conflict log.
- If it is set to 2 and the previous value is different, the update is succeeded and leaves the conflict log.
- Settings applied to all groups

```
UPDATE_APPLY_MODE = 1
```

- Settings applied to a specific group

```
GROUP_NAME = testGROUP
{
    UPDATE_APPLY_MODE = 1
    ....
    ....
}
```



For a column whose data type is long varchar or long varbinary, then only the lengths are compared for the performance reason.

## TCP\_NODELAY

- It is used only in master.
- It sets TCP\_NODELAY option for the CDC transfer socket. (This option does not affect the sync. It is fixed to TCP\_NODELAY on.)
  - 0: It offs the socket TCP\_NODELAY option.
  - 1: It ons the socket TCP\_NODELAY option. (Default)
- Settings applied to all groups

```
TCP_NODELAY = 1
```

- Settings applied to a specific group

```
GROUP_NAME = testGROUP
{
    TCP_NODELAY = 1
    ....
    ....
}
```

## HEARTBEAT\_TIMEOUT

- It can be set in master and slave.
- It sets the maximum time (second) maintaining connection if the connection is not smooth due to network disconnection or system error after replication connection between master and slave.
- The default value is 30 (seconds).
  - The minimum value is 10 (seconds).
- Settings applied to all groups

```
HEARTBEAT_TIMEOUT = 40
```

- Settings applied to a specific group

```
GROUP_NAME = testGROUP
{
    HEARTBEAT_TIMEOUT = 40
    ....
    ....
}
```

## SKIP\_COMMENT

- It can be set in master.
- It is available when a specific transaction is not replicated.
- If the same value is input as a comment when executing transaction commit after setting the corresponding value, then it skips that transaction instead of replicating it.
- Settings applied to all groups

```
SKIP_COMMENT = 'DO_SKIP'
```

- Settings applied to a specific group

```
GROUP_NAME = testGROUP
{
    SKIP_COMMENT = 'DO_SKIP'
    ....
    ....
}
```

## LOG\_CAPTURE\_INTERVAL\_1

- It can be set in master.
- It sets the execution cycle of capture operated in master. The execution cycle is set in millisecond.
- It is used to quickly detect the changes of the redo log file.
- If the value of redo log file is not changed after executing 10 times with that value, then it is converted to the value of LOG\_CAPTURE\_INTERVAL\_2 and performs capture.
- The default value is 200 (0.2 seconds), and the unit is millisecond.
- Settings applied to all groups

```
LOG_CAPTURE_INTERVAL_1 = 200
```

- Settings applied to a specific group

```
GROUP_NAME = testGROUP
{
    LOG_CAPTURE_INTERVAL_1 = 200
    ....
    ....
}
```

## LOG\_CAPTURE\_INTERVAL\_2

- It can be set in master.
- It sets the execution cycle of capture operated in master. The execution cycle is set in millisecond.
- It is used to quickly detect the changes of the redo log file.
- If the value of redo log file is not changed after executing 10 times with the value of LOG\_CAPTURE\_INTERVAL\_1, then it is converted to the corresponding value and performs capture.
- The default value is 1000(1 second), and the unit is millisecond.
- Settings applied to all groups

```
LOG_CAPTURE_INTERVAL_2 = 1000
```

- Settings applied to a specific group

```
GROUP_NAME = testGROUP
{
    LOG_CAPTURE_INTERVAL_2 = 1000
    ....
    ....
}
```

## CLUSTER

- It can be set in slave.
- It sets the connection information of N masters which is operated in cluster environment. (It consists of ID, MASTER\_IP and PORT information.)
  - ID: It is an identifier of master in slave, and only number can be input. Once the value is set, it should not be altered.
  - MASTER\_IP: It sets IP in which master is being operated.
  - PORT: It sets port in which master is being operated.
- Cluster can be set only within a group.

```
GROUP_NAME = testGROUP
{
    CLUSTER = (ID=1, MASTER_IP=192.0.0.100, PORT=21102),
              (ID=2, MASTER_IP=192.0.0.101, PORT=21103)
    ....
    ....
}
```

## ORACLE\_DRIVER

- It can be set in slave.
- It specifies the location and name of ODBC driver file provided by Oracle.
  - Currently it supports Oracle 11g and 12c.
- It can be set in any group.

```
ORACLE_DRIVER = '/app/oracle/product/11.2.0/db_1/lib/libsqora.so.11.1'
GROUP_NAME = testGROUP
```

```
{  
    ....  
    ....  
}
```

## MYSQL\_DRIVER

- It can be set in slave.
- It specifies the location and name of ODBC driver file provided by MySQL.
- It can be set in any group.

```
MYSQL_DRIVER = '/usr/lib64/libmaodbc.so'  
GROUP_NAME = testGROUP  
{  
    ....  
    ....  
}
```

## MYSQL\_DATABASE

- It can be set in slave.
- It specifies the DATABASE name of MySQL to replicate.
- The DATABASE name of MySQL has the same meaning as the SCHEMA name.
- It can be set in any group.

```
MYSQL_DATABASE = mysql  
GROUP_NAME = testGROUP  
{  
    ....  
    ....  
}
```

## PACKET\_COMPRESSION\_MODE

- It can be set in master.
- It sets whether to compress the data which is transferred from master to slave.
  - 1: Enable (Default)
  - 0: Disable



- It can be set in a specific group.

```
GROUP_NAME = testGROUP
{
    PACKET_COMPRESSION_MODE = 1
    ....
    ....
}
```

## DB2\_DRIVER

- It can be set in slave.
- It specifies the location and name of ODBC driver file provided by DB2.
- It can be set in any group.

```
DB2_DRIVER = '/usr/lib64/libdb2o.so'
GROUP_NAME = testGROUP
{
    ....
    ....
}
```

## DB2\_DATABASE

- It can be set in slave.
- It specifies the DATABASE name of DB2 to replicate.
- It can be set in any group.

```
DB2_DATABASE = db2
GROUP_NAME = testGROUP
{
    ....
    ....
}
```

## 50.4 Operating

CYCLONE can be operated in D/A or C/S environment of GOLDDILOCKS.

CONFIG file or PROTOCOL configuration of ODBC.INI should be used according to the environments as follows. CONFIG configuration takes precedence over ODBC.INI configuration.

**Table 50-7** CONFIG, ODBC.INI

Configuration	Description
PROTOCOL=DA	It is used in D/A environment. (Default)
PROTOCOL=TCP	It is used in C/S environment.

The running contents during the operation can be viewed through trace log.

Item	File
Cyclone master	\$GOLDDILOCKS_DATA/trc/cyclone_master.trc
Cyclone slave	\$GOLDDILOCKS_DATA/trc/cyclone_slave.trc



For more information about error message and its handling method stored in trace log, refer to **Troubleshooting of CYCLONE**.

## GOLDDILOCKS Connection Policy

It is the policy for CYCLONE to connect to GOLDDILOCKS.

There are two ways to connect to GOLDDILOCKS. One is that CYCLONE connects to local GOLDDILOCKS, and the other is that CYCLONE master remotely connects to slave side GOLDDILOCKS on the slave's side when performing SYNC. Both use CYCLONE config value is preferentially used, then use odbc.ini. However, when performing SYNC, PROTOCOL value is ignored and it is set to TCP no matter what.

The config properties relating to GOLDDILOCKS connection are DSN, PROTOCOL, HOST\_IP, HOST\_EXTERNAL\_IP, HOST\_PORT, USER\_ID, USER\_PW.

(USER\_ENCRYPT\_PW is listed as USER\_PW because it replaces USER\_PW.)

## Correct Examples

- It is available just with USER\_ID and USER\_PW because it is connected as D/A.

Item	File
CONFIG	USER_ID=test, USER_PW=test
GOLDILOCKS configuration of odbc.ini	-

- The information should exist either in CONFIG or in odbc.ini. HOST\_IP and HOST\_PORT are ignored because it is operated in D/A.

Item	File
CONFIG	HOST_IP=127.0.0.1, HOST_PORT=22581, USER_ID=test
GOLDILOCKS configuration of odbc.ini	USER_PW=test

- USER\_ID is operated with the test account because it is connected with TCP and CONFIG takes precedence.

Item	File
CONFIG	PROTOCOL=TCP, USER_ID=test, USER_PW=test
GOLDILOCKS configuration of odbc.ini	HOST_IP=127.0.0.1, HOST_PORT=22581, USER_ID=test2, USER_PW=test2

- HOST\_EXTERANL\_IP can not be set in slave even though it is connected as D/A.

Item	File
CONFIG	PROTOCOL=DA, HOST_EXTERNAL_IP=192.168.0.10, USER_ID=test
GOLDILOCKS configuration of odbc.ini	HOST_IP=127.0.0.1, HOST_PORT=22581, USER_PW=test

## Wrong Examples

- It is connected as D/A, but USER\_PW does not exist.

Item	File
CONFIG	HOST_EXTERNAL_IP=192.168.0.10
GOLDILOCKS configuration of odbc.ini	PROTOCOL=DA, USER_ID=test

- It is connected as TCP, but HOST\_IP does not exist.

Item	File
CONFIG	HOST_EXTERNAL_IP=192.168.0.10, USER_ID=test
GOLDILOCKS configuration of odbc.ini	PROTOCOL=TCP, HOST_PORT=22581,USER_PW=test

## Executing Option

CYCLONE should be used with the following options at run-time.

**Table 50-8** Executing options

Option	Description	Remarks
--start   -s	It starts CYCLONE.	It should be used together with --master   --slave.
--stop   -t	It terminates CYCLONE.	It should be used together with --master   --slave.
--master   -m	It is performed in master mode.	It should be used together with --start   --stop.
--slave   -l	It is performed in slave mode.	It should be used together with --start   --stop.
--status   -u	It displays the operating status of CYCLONE.	It should be used together with --master   --slave.
--conf   -c	It sets the path of configuration file which is required when executing CYCLONE.	It is input in --conf CONFIG_FILE format. It should be used together with --start. If it is not explicitly set, master uses \$GOLDILOCKS_DATA/cyclone.master.conf, and slave uses \$GOLDILOCKS_DATA/cyclone.slave.conf.
--silent   -i	It sets not to output messages.	-
--reset   -r	It resets operational information of the replication.	It is input in --reset TABLE_NAME or --reset all format. It should be described within a single quote (') when resetting multiple tables.
--group   -g	It sets a specific group.	It is input in --group GROUP_NAME format.
--help   -h	It outputs the help message.	
--sync   -n	It performs data synchronization.	It should be used together with --master   --slave.
--encrypt   -e	It encrypts the user password with the given key.	-
--key   -k	It sets the encryption key when performing the --encrypt option. If USER_ENCRYPT_PW is used in the config, it sets the decryption key.	-
--info   -o	It displays the status of the table which is currently being replicated.	It should be used together with --master, --group.
--recovery   -v	It is used when passing the replication being performed in a standalone mode of cluster environment to another cluster member.	It is used in --recovery GROUP_NAME form, and GROUP_NAME describes CYCLONE GROUP_NAME of a slave which was previously performed.

Option	Description	Remarks
<code>--stand-alone   -S</code>	It is operated in a standalone mode of cluster environment. (It is operated in a cluster mode in cluster environment.)	It is valid only in master. (It is set in the configuration file in slave.)
<code>--local   -a</code>	It is used when synchronizing the table sharded in cluster environment. It synchronizes only the data in the corresponding cluster group.	It should be used together with <code>--sync</code> .

- It executes all groups in master mode by using the default environment file.

```
prompt> cyclone --master --start
```

- It terminates all groups in master mode.

```
prompt> cyclone --master --stop
```

- It executes all groups in slave mode by using the default environment file.

```
prompt> cyclone --slave --start
```

- It terminates all groups in slave mode.

```
prompt> cyclone --slave --stop
```

- It executes only the TEST\_GROUP group in master mode.

```
prompt> cyclone --master --start --group TEST_GROUP
```

- It terminates only TEST\_GROUP group among the groups operated in master mode.

```
prompt> cyclone --master --stop --group TEST_GROUP
```

- It sets the TEST\_CONFIG file in slave mode and executes it.

```
prompt> cyclone --slave --start --conf TEST_CONFIG
```

- It encrypts GOLDBLOCKS user password.

```
prompt> cyclone --encrypt test --key 1234
Cyclone Encrypted Passwd : 'YFH+bpBNvk='
```

- USER\_ENCRYPT\_PW is set in the config.

```
prompt> cyclone --master --start --key 1234
```

- It deletes the existing replications of master and slave, and newly starts it.

```
prompt> cyclone --master --start --reset all
```

```
prompt> cyclone --slave --start --reset all
```

- It deletes the existing replications of only the tables T1, T2 in master, and starts it newly from the current point.

```
prompt> cyclone --master --start --reset 'T1, T2'
```

```
prompt> cyclone --slave --start
```

- It displays the current replication status per each table on master side.

```
prompt> cyclone --master --info --group GROUP1
```

```
=====
GROUP NAME = GROUP1
=====
SCHEMA NAME      : PUBLIC
TABLE NAME       : T1 (GIVE-UP (DDL-LSN:129541))
PHYSICAL ID     : 5299989643264
=====
SCHEMA NAME      : PUBLIC
TABLE NAME       : T2 (ACTIVE (CAPTURE-START-LSN:128922))
PHYSICAL ID     : 35549444308992
=====
SCHEMA NAME      : PUBLIC
TABLE NAME       : T3 (ACTIVE (CAPTURE-START-LSN:128922))
PHYSICAL ID     : 35558034243584
=====
SCHEMA NAME      : PUBLIC
TABLE NAME       : T4 (ACTIVE (CAPTURE-START-LSN:128922))
PHYSICAL ID     : 35566624178176
=====
TOTAL  COUNT : 4
GIVE-UP COUNT : 1
=====
```



For more information about examples of adding/deleting node or group, refer to **Adding and Deleting Nodes**.

For more information about examples of initializing replication, refer to **Initializing Replication**.

## 50.5 Operating Examples

The structure of operating CYCLONE is as follows.

**Figure 1** The structure of operating CYCLONE

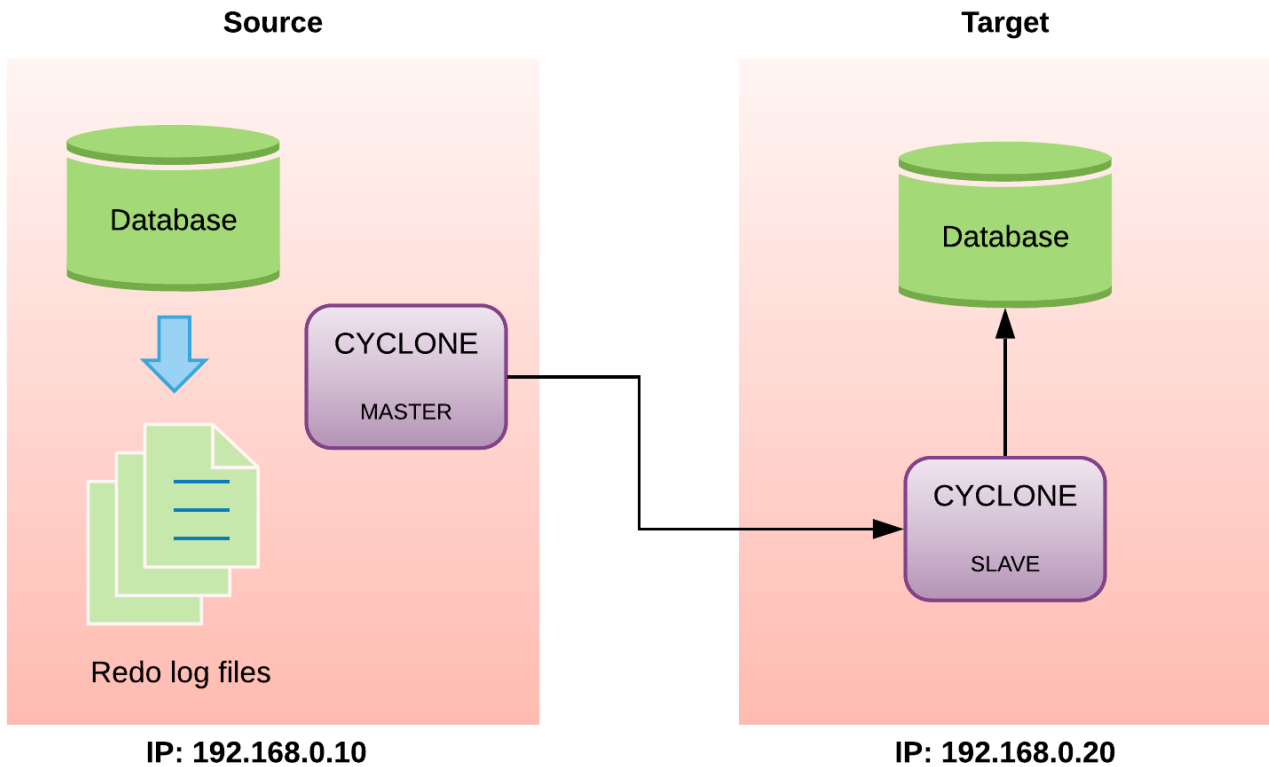

- Device structure
  - The source device which is the original data
    - GOLDDILOCKS IP: 192.168.0.10
    - GOLDDILOCKS port: 22581
    - The table to be replicated: T1, T2
  - The remote target device for replication
    - GOLDDILOCKS IP: 192.168.0.20
    - GOLDDILOCKS port: 22581

### Operating Order

1. Set the original GOLDDILOCKS environment.
2. Set the remote GOLDDILOCKS environment.
3. Set the CYCLONE MASTER environment.
4. Set the CYCLONE SLAVE environment.



5. Execute and operate it.

## Original GOLDILOCKS Configuration

Execute all described **Requirements**.

Create tables T1, T2 for testing.

```
gSQL > CREATE TABLE T1( COL1 INTEGER PRIMARY KEY, COL2 VARCHAR(20) );
gSQL > CREATE TABLE T2( COL1 INTEGER PRIMARY KEY, COL2 VARCHAR(20) );
gSQL > COMMIT;
```

## Remote GOLDILOCKS Configuration

Execute **Registering User and Setting Privileges**.

## CYCLONE MASTER Configuration

- CYCLONE MASTER configuration file
  - Storing path: \$GOLDILOCKS\_DATA/conf/cyclone.master.conf
  - It is the source device.
- It is connected with D/A of the same device, so HOST information does not exist.

```
USER_ID = cdc_user
USER_PW = cdc_password
GROUP_NAME = GROUP1
{
    PORT = 21102
    CAPTURE_TABLE =
    (
        T1,
        T2
    )
}
```

## CYCLONE SLAVE Configuration

- CYCLONE SLAVE configuration file
  - Storing path: \$GOLDILOCKS\_DATA/conf/cyclone.slave.conf
  - It is the target device.
- It is connected with D/A of the same device, but HOST\_IP and HOST\_PORT are used for SYNC.

```
USER_ID = cdc_user
USER_PW = cdc_password
HOST_IP = 192.168.0.20
HOST_PORT = 22581
GROUP_NAME = GROUP1
{
    PORT = 21102
    APPLY_TABLE =
    (
        T1 TO T1,
        T2 TO T2
    )
}
```

## Executing and Operating

- Execute CYCLONE master.
  - It should be executed in the source device.

```
cyclone --master --start --conf $GOLDILOCKS_DATA/conf/cyclone.master.conf
```

- Execute CYCLONE SLAVE.
  - It should be executed in the target device.

```
cyclone --slave --start --conf $GOLDILOCKS_DATA/conf/cyclone.slave.conf
```

## Synchronizing Data

- Synchronizing data
  - It copies all data from the master to the slave, and it performs the replication.
  - It copies the table data in the master to be replicated to the table in the slave when performing data synchronization.
- It should be performed after giving `--sync` option to both master and slave when starting the operation.
  - `--sync all` is used to sync all tables, and `--sync TABLE_NAME` is used to sync a specific table.
    - The table name of master is described in `TABLE_NAME`. (The table name of master should be described in `TABLE_NAME` even when it is operated in slave.)
- `HOST_IP` (or `HOST_EXTERNAL_IP`) and `HOST_PORT` should be set in `CONFIG` or `odbc.ini` of slave though it is D/A.



- If there is data in the slave table participating in the replication, data synchronization may not be properly performed due to duplicated PK. Therefore, the user should manually delete the data from the slave table before data synchronization.
- When data synchronization is performed by using the `--sync` option, the previous information of replication is deleted. In other words, the `--reset` option is internally forced to be set when using the `--sync` option.
- Cyclone which is operated as master directly connects to GOLDILOCKS which is operated as slave and it performs the data synchronization.



If the target DB of the slave is Oracle or MySQL, then SYNC feature is not operable.

- Execute CYCLONE master
  - It should be executed in the source device.

```
cyclone --master --start --conf $GOLDILOCKS_DATA/conf/cyclone.master.conf --sync all
```

- Execute CYCLONE SLAVE
  - It should be executed in the target device.

```
cyclone --slave --start --conf $GOLDILOCKS_DATA/conf/cyclone.slave.conf --sync --all
```

- The following is an example of a sync error.
  - It is recommended to delete the data from tables of slave to prevent an error.
  - Execute MASTER.

```
gSQL> CREATE TABLE T1( COL1 INTEGER PRIMARY KEY, COL2 VARCHAR(20) );
gSQL> INSERT INTO T1 VALUES( 1, 'HELLO' );
```

- Execute SLAVE.

```
gSQL> CREATE TABLE T1( COL1 INTEGER PRIMARY KEY, COL2 VARCHAR(20) );
gSQL> INSERT INTO T1 VALUES( 1, 'BYE' );
```

- Execute MASTER.

```
cyclone --master --start --sync all
```

- Execute SLAVE.

```
cyclone --slave --start --sync all
SLAVE cyclone log
[RECEIVER] start the data synchronization.
[RECEIVER] Error Occurred.
STOP Done.
```

An error occurs and the sync does not operate due to an attempt to using the same value in the primary key.

## Initializing Replication Information

- Initializing replication information
  - It restarts the replication from current point for the entire table or a specific table participating in the replication.
  - It is performed by using the `--reset TABLE_NAME` option or the `--reset ALL` option.
- Differences of between master and slave when performing the `--reset` option
  - Master stores table information and column information participating in the replication as meta. If RESET is performed in master by using the `--Reset ALL` option or the `Reset Table_name` option, it removes the meta in the table and configures meta again by using the information at the current point.
    - The `--reset` option should be performed in master to replicate again the table which is given up during the replication performing DDL.
  - The slave stores the information for recovery when restating the replication. `--reset All` or `--reset TABLE_NAME` should be described when executing slave as same as when executing master.



- Add the `--reset ALL` option to initialize all tables participating in the replication when performing master/ slave.

```
prompt> cyclone --master --start --reset ALL
```

```
prompt> cyclone --slave --start --reset ALL
```

- Add the `--reset TABLE_NAME` option when performing master to initialize the replication in formation of a specific table.

- The table name of when performing slave should be as same as that of when performing master.

```
prompt> cyclone --master --start --reset T1
```

```
prompt> cyclone --slave --start
```

- A single quote (') should be used to initialize two or more tables.

```
prompt> cyclone --master --start --reset 'T1 T2'
```

```
prompt> cyclone --master --start --reset 'T1, T2'
```

## Recovery

- When using recovery,
  - It is used when handing over the replication to another cluster member in the same group and proceeding it, due to an error of master while the replication is being processed by using a standalone option in cluster environment.
  - It is performed with `--recovery GROUP_NAME` in master, and `GROUP_NAME` describes the group name of slave which previously performed the replication.



The process of resetting the replication information

1. Replicate with G1N1 member (standalone) in cluster environment.

```
prompt> cyclone --master --start --reset ALL --group g1n1_master --stand-alone
```

```
prompt> cyclone --slave --start --reset ALL --group g1n1_slave
```

2. Stop operating the existing cyclone to stop the cluster member or to hand over the service.

```
prompt> cyclone --master --stop
```

```
prompt> cyclone --slave --stop
```

3. Service the new replication (G1N2) by using the information of the existing replication. (G1N1)

```
prompt> cyclone --master --start --reset all --group g1n2_master --stand-alone --recovery g1n1_
slave
prompt> cyclone --master --start --reset all --group g1n2_slave
```

## 50.6 Operating CYCLONE in Cluster

### Requirements

- It provides a method to replicate members in the same cluster group in cluster environment.
  - Master and slave are operated in a relationship of 1 : 1 in standalone environment.
  - Master and slave are operated in a relationship of N: 1 in cluster environment.
- Available environment
  - Master should be cluster environment. (It is automatically detected.)
  - Slave can be either standalone or cluster environment.
- The status of master connected to slave is called as a node.



1. Master connecting to a slave should be a member in the same cluster group.
  - If it is a member of another cluster group, it should be operated in another slave.
2. If master is cluster environment, CYCLONE is basically operated in cluster mode, and --stand-alone option should be used to operate CYCLONE in standalone mode.
  - --stand-alone option is used only when performing master.
  - If the cluster information of master is described by adding CLUSTER option to configuration file, then slave is operated in cluster mode.

### Operating

#### Starting and Terminating

- The time of terminating master and slave are different each in standalone environment and in cluster environment.
  - Standalone environment
    - If master is terminated, then slave is automatically terminated.
    - If slave is terminated, master is switched to an idle state but it is not terminated.
  - Cluster environment
    - Even when master is terminated, slave is not terminated. If another master is already connected, then the replication proceeds. If any master is not connected, slave is switched to an idle state.
    - If slave is terminated, all connected masters are automatically terminated.



If master is running in cluster environment, then slave should use CLUSTER\_LIST option. If standalone option is used to run master in cluster environment, then slave should not use CLUSTER\_LIST option.

## Node Type

In cluster environment, CYCLONE classifies master connecting to slave into a trust node and a non-trust node.

**Table 50-9** Node in cluster environment

Node	Description	Replication
Trust node	It is a node all of whose tables participating in replication are online.	O
Non-trust node	It is a node one or more of whose tables participating in replication are offline.	X

## Operation According to Node Status

- Switching from a non-trust node to a trust node
  - It is executed when all tables are switched to online by rebalancing the cluster member while an offline table exists.
  - The node is automatically switched from a non-trust node to a trust node, and participates in replication.
- Switching from a trust node to a non-trust node
  - It is executed when a table being replicated in another cluster member in operation is altered while the cluster member is terminated and is not operated.
  - A non-trust node is automatically altered when a cluster member joins, and it is excluded from replication.



- The replication is maintained when one or more trust nodes exist among masters participating in the replication.
- A trust node is not restricted to a specific node, and any node is allowed regardless of node types.
- If all masters participating in replication becomes non-trust nodes, the replication does not proceed any more, and the replication does not start again even when they become trust nodes.
- At least one or more trust nodes are required to proceed the replication in cluster environment.



# Executing

## Configuration File

The configuration file of master is as same as that of standalone.

The following is an example of configuring G1N1 master environment, and IP of that device is assumed as 192.168.0.10.

- There is nothing to alter for master even in cluster environment.

```
USER_ID = cdc_user
USER_PW = cdc_password
GROUP_NAME = G1N1_Master
{
    PORT = 21011
    CAPTURE_TABLE =
    (
        T1,
        T2
    )
}
```

The following is an example of configuring G1N2 master environment, and IP of that device is assumed as 192.168.0.20.

- There is nothing to alter for master even in cluster environment.

```
USER_ID = cdc_user
USER_PW = cdc_password
GROUP_NAME = G1N2_Master
{
    PORT = 21012
    CAPTURE_TABLE =
    (
        T1,
        T2
    )
}
```

CLUSTER is added to the configuration file of slave to describe the information of master.

- CLUSTER consists of ID, MASTER\_IP, and PORT. (The sequence does not matter.)
  - ID is input in numbers, and it is used as an internal delimiter to distinguish master in slave. Once it is set, it can not be altered. (If it is altered, it is recognized as a different master.)
  - MASTER\_IP is IP in which CYCLONE MASTER is operated in CLUSTER member.
  - PORT is a PORT in which CYCLONE MASTER is operated in CLUSTER member.
- The information of a CLUSTER is described in parentheses, and it is distinguished by a comma (,) between parentheses.

MASTER\_IP, PORT which are the master information of CLUSTER are described in CLUSTER configuration.

```

USER_ID = cdc_user
USER_PW = cdc_password
GROUP_NAME = G1_Slave
{
    CLUSTER = ( ID = 1, MASTER_IP = 192.168.0.10, PORT = 21011 ),
              ( ID = 2, MASTER_IP = 192.168.0.20, PORT = 21012 )
    APPLY_TABLE =
    (
        T1 TO T1,
        T2 TO T2
    )
}

```

## Executing Method

### Executing in Master

- It is executed in G1N1.

```
cyclone --master --start --conf $GOLDILOCKS_DATA/conf/cyclone.master.conf --group G1N1_Master
```

- It is executed in G1N2.

```
cyclone --master --start --conf $GOLDILOCKS_DATA/conf/cyclone.master.conf --group G1N2_Master
```

### Executing in Slave

```
cyclone --slave --start --conf $GOLDILOCKS_DATA/conf/cyclone.slave.conf --group G1_Slave
```

## SYNC Method

### Executing Master

It is executed in G1N1. (It is master of which SYNC is to be executed, and it uses --sync option.)

```
cyclone --master --start --conf $GOLDILOCKS_DATA/conf/cyclone.master.conf --sync all
```

### Executing Slave

```
cyclone --slave --start --conf $GOLDILOCKS_DATA/conf/cyclone.slave.conf --sync all
```



--local option should be used when syncing if a sharded table participates in the replication. It is because the data of a sharded table exists only in each cluster group, and data in other cluster groups are synchronized when executing sync without --local option. However, if all tables participating in the replication in cluster environment are cloned tables, then --local option does not need to be used.

## Others

--reset option can be used as same as it is used in standalone environment.

## 50.7 Monitoring (CYMON)

CYMON (CYclone MONitor) is a tool for monitoring CYCLONE which is a CDC replication tool. It periodically updates the monitoring information of CYCLONE to GOLDDILOCKS operated as master.

**Table 50-10** Execution files

File name	Description
cymon	Monitoring cyclone

### Configuration File

The configuration file of cymon uses the configuration file used when running cyclone as master. If a specific configuration file is not set by using the `--conf` option, the `$GOLDDILOCKS_DATA/conf/cyclone.master.conf` file is read as the default when cyclone is run as master.



CYMON should be run on the device which is as same as the device of which CYCLONE runs as master.

### Monitoring Contents

#### CYMON

CYMON periodically updates the operating information of CYCLONE to the `CYCLONE_MONITOR_INFO` table of GOLDDILOCKS. The monitoring information is as follows.

**Table 50-11** CYCLONE\_MONITOR\_INFO

Column	Description
GROUP_NAME	It is the name of a group in which CYCLONE was executed.
TIME	It is the information of time at which the information was updated. (YYYY-MM-DD HH24:MI:SS)
MASTER_STATE	It is the state of CYCLONE which is operated as MASTER. <ul style="list-style-type: none"> <li>N/A: The state is unknown.</li> <li>READY: It is waiting for connection of SLAVE</li> <li>RUNNING: SLAVE is connected and the replication is running.</li> </ul>
SLAVE_STATE	It is the state of CYCLONE which is operated as SLAVE.

Column	Description
	<ul style="list-style-type: none"> <li>N/A: The state is unknown.</li> <li>RUNNING: The replication is running.</li> </ul>
MASTER_PORT	It is the information of PORT on which CYCLONE operated in MASTER is waiting for slave.
SLAVE_IP	It is an IP address of the device connected with CYCLONE SLAVE.
REDO_LOG_FILESEQ	It is the sequence number of the redo log file of the running GOLDILOCKS.
REDO_LOG_BLOCKSEQ	It is the block sequence number of the redo log file of the running GOLDILOCKS.
CAPTURE_FILESEQ	It is the sequence number of the redo log file being captured by CYCLONE master.
CAPTURE_BLOCKSEQ	It is the block sequence number of the redo log file being captured by CYCLONE master.
APPLY_FILESEQ	It is the sequence number of the redo log file being processed by CYCLONE slave.
APPLY_BLOCKSEQ	It is the block sequence number of the redo log file being processed by CYCLONE slave.
CAPTURE_INTERVAL	It is the number of the remaining redo log blocks to be processed by CYCLONE master. <ul style="list-style-type: none"> <li>1 block = 512 bytes (Redo log block size = 512 bytes)</li> </ul>
CAPTURE_INTERVAL_SIZE	It is the size of the remaining redo log files to be processed by CYCLONE master.
TOTAL_TX_COUNT	It is the number of all transactions captured by CYCLONE master.
CAPTURE_TX_COUNT	It is the number of all transactions in which the replication targets are included among the transactions captured by CYCLONE master.
CAPTURE_COMMIT_LSN	It is the commit log number of the last transaction which was captured in CYCLONE master. It is not updated if there is not a transaction to be captured any more.
APPLY_COMMIT_LSN	It is the commit log number of the transaction being processed in CYCLONE slave. It is not updated if there is not a transaction to be processed any more.



INTERVAL information is the CAPTURE information for analyzing the redo log file of CYCLONE operated as master, and it is not the information reflected by APPLIER in CYCLONE SLAVE.

## Executing and Monitoring

### Executing Option

Table 50-12 Executing option

Option	Description	Remarks
--conf   -c	It sets the configuration file path.	<p>It is input in --conf CONFIG FILE format.</p> <ul style="list-style-type: none"> <li>It should set the file as same as the configuration file used when running CYCLONE as master.</li> </ul>

Option	Description	Remarks
--start   -s	It executes CYMON.	-
--stop   -t	It terminates CYMON.	-
--status   -u	It displays the operating status of CYMON.	-
--cycle   -y	It sets the update cycle of monitoring information.	It is input in --cycle X format. <ul style="list-style-type: none"> <li>It should be entered in seconds.</li> </ul>
--key   -k	It sets the decryption key when USER_ENCRYPT_PW is used in config.	-
--trace   -r	It simultaneously records the monitoring information of capture on the trace log.	The trace log is recorded in \$GOLDLOCKS_DATA/trc/cymon.trc.
--silent   -i	It sets not to output the message.	-
--help   -h	It outputs the help message.	-

## Examples

- Execute CYMON (Update the monitoring information of cyclone\_monitor\_info table.)
  - Executes CYMON to update the monitoring information per second. It continuously updates the information until terminating CYMON.

```
cymon --start --cycle 1
```

- View the monitoring information

```
gSQL> \set vertical on
gSQL> select * from cyclone_monitor_info;
      GROUP_NAME # GROUP1
           TIME # 2015-01-13 17:34:53
  MASTER_STATE # READY
   SLAVE_STATE # N/A
  MASTER_PORT  # 21102
     SLAVE_IP   # null
  REDO_LOG_FILESEQ # 0
  REDO_LOG_BLOCKSEQ # 52392
  CAPTURE_FILESEQ # 0
  CAPTURE_BLOCKSEQ # 0
    APPLY_FILESEQ # 0
    APPLY_BLOCKSEQ # 0
  CAPTURE_INTERVAL # 0
CAPTURE_INTERVAL_SIZE # 0
```

```
CAPTURE_COMMIT_LSN # 0
APPLY_COMMIT_LSN # 0
```

- The information above describes that only CYCLONE MASTER is being operated and SLAVE is waiting.

```
gSQL> \set vertical on
gSQL> select * from cyclone_monitor_info;
      GROUP_NAME # GROUP1
           TIME # 2015-01-13 17:36:17
MASTER_STATE # RUNNING
SLAVE_STATE # RUNNING
MASTER_PORT # 21102
      SLAVE_IP # 127.0.0.1
REDO_LOG_FILESEQ # 0
REDO_LOG_BLOCKSEQ # 52811
CAPTURE_FILESEQ # 0
CAPTURE_BLOCKSEQ # 52811
      APPLY_FILESEQ # 0
      APPLY_BLOCKSEQ # 52811
CAPTURE_INTERVAL # 0
CAPTURE_INTERVAL_SIZE # 0
CAPTURE_COMMIT_LSN # 1023
APPLY_COMMIT_LSN # 1023
```

- The information above describes that CYCLONE MASTER and SLAVE are being operated.
- Execute CYMON (Store the monitoring information in trace log)
  - The monitoring information is stored not only in a monitoring table but also in a trace log since when CYMON is normally executed with master.
  - Generally, it is used when unable to view cyclone\_monitor\_info table due to an error of the master DB. In this case, the information of master DB such as information of REDO\_LOG\_FILESEQ and REDO\_LOG\_BLOCKSEQ are not included.
  - Trace log is in \$GOLDILOCKS\_DATA/trc/cymon.trc.

```
cymon --start --trace
```

- View the monitoring information (When using --trace option)
  - It stores the monitoring information since when the cyclone master is normally executed.

```
GROUP_NAME          TIME                MASTER_STATE SLAVE_STATE  MASTER_PORT  SLAVE_IP
CAPTURE_FILESEQ    CAPTURE_BLOCKSEQ  TOTAL_TX_COUNT CAPTURE_TX_COUNT  CAPTURE_COMMIT_LSN
APPLY_FILESEQ      APPLY_BLOCKSEQ    APPLY_COMMIT_LSN
```

```

-----
-----
-----
GROUP1          2016-11-02 15:43:03 READY      N/A          21102 null
0              0              0              0              0              0
0              0
GROUP2          2016-11-02 15:43:03 READY      N/A          21103 null
0              0              0              0              0              0
0              0

```

- The information above describes that only CYCLONE MASTER is being operated and SLAVE is waiting.

```

GROUP_NAME      TIME                MASTER_STATE SLAVE_STATE  MASTER_PORT  SLAVE_IP
CAPTURE_FILESEQ CAPTURE_BLOCKSEQ TOTAL_TX_COUNT CAPTURE_TX_COUNT  CAPTURE_COMMIT_LSN
APPLY_FILESEQ   APPLY_BLOCKSEQ    APPLY_COMMIT_LSN
-----
-----
-----
GROUP1          2016-11-02 15:43:11 RUNNING     RUNNING     21102 192.168.0.206
7              52779            0              0              15346        7
52779          15346
GROUP2          2016-11-02 15:43:11 READY      N/A          21103 null
0              0              0              0              0              0
0              0

```

- The information above describes that CYCLONE MASTER (group1) and SLAVE are being operated.

- View the operating status of CYMON

```

$ cymon --status
=====
|           CYMON STATUS           |
=====
|   Service is running...         |
-----

```

- Terminate CYMON

```

$ cymon --stop
stop done.

```



**51.**

---

**LOGMIRROR**

## 51.1 LOGMIRROR

LOGMIRROR is a replication tool which copies the redo logs generated by GOLDILOCKS to the remote location for the configuration of the same redo log file.

### Overview

CYCLONE, using the CDC method, analyzes and replicates the redo log file generated during the operation of GOLDILOCKS. Therefore, if the operating server is failed when analysis of the redo log file is not completed, then unanalyzed redo log file is not replicated and the data is lost.

However, if the redo logs are sent to a remote location without data loss and the redo log file is configured by using LOGMIRROR, then this problem of CYCLONE can be solved.

LOGMIRROR is a tool for eliminating the data loss which is caused because CYCLONE uses the ASYNC method, and it should work together with CYCLONE.

### Operational Features

- It is performed being divided into master and slave. Only one LOGMIRROR per GOLDILOCKS is allowed to be operated.
- Master and slave can use the TCP/IP and infiniband communication.
  - Network speed significantly affects the GOLDILOCKS operation speed.
- The replication target is the redo log file of GOLDILOCKS.
- The original database should be operated in Transactional Data Store (TDS) mode.
  - LOGMIRROR has the same operational characteristics of CYCLONE because it should be operated together with CYCLONE.

### Performance Degradation Factors of GOLDILOCKS When Operating LOGMIRROR

LOGMIRROR sends the redo logs generated by GOLDILOCKS to the remote location before storing them in the file, then processes the next after it is normally processed. Therefore, the network speed between the replication devices is an important factor of the performance, and it can cause performance degradation than GOLDILOCKS operated without LOGMIRROR. However, the high speed infiniband is supported t

o minimize the performance degradation.

## 51.2 Requirements

### GOLDILOCKS Requirement

The followings should be set in GOLDILOCKS before performing LOG MIRROR.

#### LOG\_MIRROR\_MODE

The LOG\_MIRROR\_MODE property is set to use LOGMIRROR in GOLDILOCKS. When it is activated, the resources which temporarily store the redo logs generated by GOLDILOCKS before LOGMIRROR sends them to a remote location are allocated.

- If the LOG\_MIRROR\_MODE property is changed, it is applied after restarting GOLDILOCKS.
- The changes are added or reflected in the property file.
  - Property file: goldilocks.properties.conf
  - Property setting: LOG\_MIRROR\_MODE = 1

Or, the following statement is executed in gSQL.

```
gSQL> ALTER SYSTEM SET LOG_MIRROR_MODE=1 SCOPE=FILE;  
System altered.
```

#### LOG\_MIRROR\_SHARED\_MEMORY\_STATIC\_SIZE

LOG\_MIRROR\_SHARED\_MEMORY\_STATIC\_SIZE sets the temporary storage space used by LOGMIRROR.

- It is a temporary storage space used before storing redo log file from redo log buffer.
  - The set value is related to MAXIMUM\_FLUSH\_LOG\_BLOCK\_COUNT used when storing the redo log file.
- The default value is 100 M.
  - The minimum value is 10 M, and the maximum value is 1 G.
  - Too small set value can affect the performance.
- If LOG\_MIRROR\_SHARED\_MEMORY\_STATIC\_SIZE property is changed, then it is applied after the GOLDILOCKS is restarted.
- The changes are added or reflected in the property file.
  - Property file: goldilocks.properties.conf
  - Property setting: LOG\_MIRROR\_SHARED\_MEMORY\_STATIC\_SIZE = the set value

Or, the following statement is executed in gSQL.

```
gSQL> ALTER SYSTEM SET LOG_MIRROR_SHARED_MEMORY_STATIC_SIZE = 200M SCOPE=FILE;  
System altered.
```

## LOG\_MIRROR\_TIMEOUT

When interworking with LOGMIRROR, GOLDILOCKS includes the step of waiting for the response from LOG MIRROR. Too slow response causes the degradation of GOLDILOCKS performance. LOG\_MIRROR\_TIMEOUT sets the response time so when there is not any response after the time is over, LOGMIRROR stops the service, but only the GOLDILOCKS continues the service.

When restarting LOGMIRROR to perform LOGMIRROR again, it is normally operated after the recovery process.

- The default value is '0'.
  - 0 refers to an infinite waiting.
  - It can be set in seconds.
- If LOG\_MIRROR\_TIMEOUT property is changed, it is immediately reflected.
- The changes are added or reflected in the property file.
  - Property file: goldilocks.properties.conf
  - Property setting: LOG\_MIRROR\_TIMEOUT = the set value

Or, the following statement is executed in gSQL.

```
gSQL> ALTER SYSTEM SET LOG_MIRROR_TIMEOUT = 20;  
System altered.
```



The GOLDILOCKS requirements for operating CYCLONE should also be applied.

## 51.3 Configuration

### Configuration File

The information and options required for the operation can be set by using the configuration file when executing LOGMIRROR.

- If a specific configuration file is not set by using the --conf option, a specific file is read at \$ GOLDILOCKS\_DATA / conf directory. The logmirror.master.conf file is read when operating as master and the logmirror.slave.conf file is read when operating as slave.

**Table 51-1** Configuration contents

Name	Description	Coverage
PORT	It sets the port to be used for the communication between master and slave.	Master/ slave
DSN	It sets Data Source Name.	Master
HOST_IP	It sets the host IP address which is operated by GOLDILOCKS.	Master
HOST_PORT	It sets the host port which is operated by GOLDILOCKS.	Master
USER_ID	It sets the user name.	Master
USER_PW	It sets the user password.	Master
USER_ENCRYPT_PW	It sets encrypted user password.	Master/ slave
LOG_PATH	It sets the path in which the replicated redo log file is to be stored.	Slave
MASTER_IP	It sets the IP address of the device which is being operated by the log mirror master.	Slave
HEARTBEAT_TIMEOUT	It sets the maximum time (second) maintaining connection if the connection is not smooth due to network disconnection or system error after replication connection.	Master/ slave
TCP_NODELAY	It sets TCP_NODELAY option of a socket. (The default value is 1.) <ul style="list-style-type: none"> <li>• 0: TCP_NODELAY off</li> <li>• 1: TCP_NODELAY on</li> </ul>	Master

### Configuration Options

#### PORT

- It sets the port used for the communication between master and slave.
- It can be set in master and slave.

PORT=21106

## DSN

- It sets the data source name required for the access to GOLDILOCKS.
- It can be set in master.

DSN = GOLDILOCKS

## HOST\_IP

- It sets the IP address of GOLDILOCKS in which LOGMIRROR is to be operated.
- It should be set together with HOST\_PORT.
- It can be set in master.

HOST\_IP = 127.0.0.1

## HOST\_PORT

- It sets the port of GOLDILOCKS on which LOGMIRROR is to be operated.
- It should be set together with HOST\_IP.
- It can be set in master.

HOST\_PORT = 22531

## USER\_ID

- It sets the user ID required for the access to GOLDILOCKS.
- It can be set in master.

USER\_ID = testID

## USER\_PW

- It sets the user password required for the access to GOLDILOCKS.
- It can be set in master.

```
USER_PW = testPW
```

## USER\_ENCRYPT\_PW

- It sets the user password which is required for the access to GOLDILOCKS by encrypting.
- It is used instead of USER\_PW.
- Encrypted user password is created by `[logmirror --encrypt user password --key the key to be encrypted]`.
- If this value is used, then `--key` option should be used when executing logmirror. (In this case, the key value as same as that created with `--encrypt` should be used.

```
USER_ENCRYPT_PW = 't33KImiqvhqNyfN+uZmFrw=='
```

## LOG\_PATH

- It sets the path in which the replicated redo log file is to be stored.
  - The set path should be an absolute path.
  - The path is set by using a single quote (').
- It can be set in slave.

```
LOG_PATH = '/data/wal'
```

## MASTER\_IP

- It sets the IP address of the device of which LOGMIRROR master is operating.
- It can be set in slave.

```
MASTER_IP = 192.168.0.100
```

## HEARTBEAT\_TIMEOUT

- It can be set in master and slave.
- It sets the maximum time (second) maintaining connection if the connection is not smooth due to network disconnection or system error after replication connection between master and slave.
- The default value is 30 (seconds).
  - The minimum value is 10 (seconds).

```
HEARTBEAT_TIMEOUT = 40
```



## TCP\_NODELAY

- It is used only in master.
- It sets TCP\_NODELAY option for the LogMirror transfer socket.
  - 0: It offs the socket TCP\_NODELAY option.
  - 1: It ons the socket TCP\_NODELAY option. (Default)

■ TCP\_NODELAY = 1

## 51.4 Operating

The executing environment of master/ slave of LOGMIRROR is as follows.

**Table 51-2** Executing environment

Item	Whether to operate GOLDILOCKS	Description
Master	O	When operating as master, LOGMIRROR should be operated at the device in which GOLDILOCKS is operated.
Slave	X	When operating as slave, GOLDILOCKS is not required to be operated and the storage space in the disk is required to store the redo log file.

The operating contents during the execution can be viewed through a trace log.

Item	File
Master	\$GOLDILOCKS_DATA/trc/LogMirror_master.trc
Slave	\$GOLDILOCKS_DATA/trc/LogMirror_slave.trc



For more information about the error messages and handlings stored in the trace log, refer to **Troubleshooting of LOGMIRROR**.

## Operating LOGMIRROR

LOGMIRROR can normally replicate the redo log file only when the following procedures should be completed even after the GOLDILOCKS configuration, initializing and operating master/ slave.



SWITCH of the redo log file should occur to start the replication. LOGMIRROR starts the normal operation after generating the new log file. Therefore, the following step should be performed.

```
gSQL> ALTER SYSTEM SWITCH LOGFILE;
System altered.
```



The redo log file replicated by LOGMIRROR is continuously stored, and it is not automatically deleted. Therefore, the file management such as deleting or moving is regularly required according to the environment of the operating device.

## Executing Option

Table 51-3 Execution options

Option	Description	Remarks
--start   -s	It executes LOGMIRROR.	It should be used together with --master   --slave.
--stop   -t	It terminates LOGMIRROR.	It should be used together with --master   --slave.
--master   -m	It is performed in master mode.	It should be used together with --start   --stop.
--slave   -l	It is performed in slave mode.	It should be used together with --start   --stop.
--conf   -c	It sets the configuration file path.	It is input in --conf CONFIG_FILE format.
--infiniband   -f	It uses infiniband network environment.	It is not input when using TCP/IP environment.
--silent   -i	It sets not to output the message.	-
--help   -h	It sets to output the help message.	-

- Execute it in master mode by using the default configuration file.

```
prompt> logmirror --master --start
```

- Terminate the LOGMIRROR which is being operated in master mode.

```
prompt> logmirror --master --stop
```

- Execute it in slave mode by using the default configuration file.

```
prompt> logmirror --slave --start
```

- Terminate the LOGMIRROR which is being operated in slave mode.

```
prompt> logmirror --slave --stop
```

- Execute it in master mode by using TEST\_CONFIG file and infiniband network.

```
prompt> logmirror --master --start --conf TEST_CONFIG --infiniband
```

- Execute it in slave mode by using TEST\_CONFIG file and infiniband network.

```
prompt> logmirror --slave --start --conf TEST_CONFIG --infiniband
```



For examples of initializing LOGMIRROR, refer to **LOGMIRROR**.

## 51.5 Examples of Interworking with CYCLONE

Interworking of CYCLONE, the CDC replication tool, with LOGMIRROR, the replication tool of the redo log file, eliminates the risk of data loss.

Tool	Function	Interworking
CYCLONE	Replication of CDC	If it is independently operated it may cause the data loss.
LOGMIRROR	Replication of REDO LOG FILE	If it is operated together it does not cause the data loss.

The following describes the examples of interworked operation, and its structure.

Figure 1 Example of operating structure

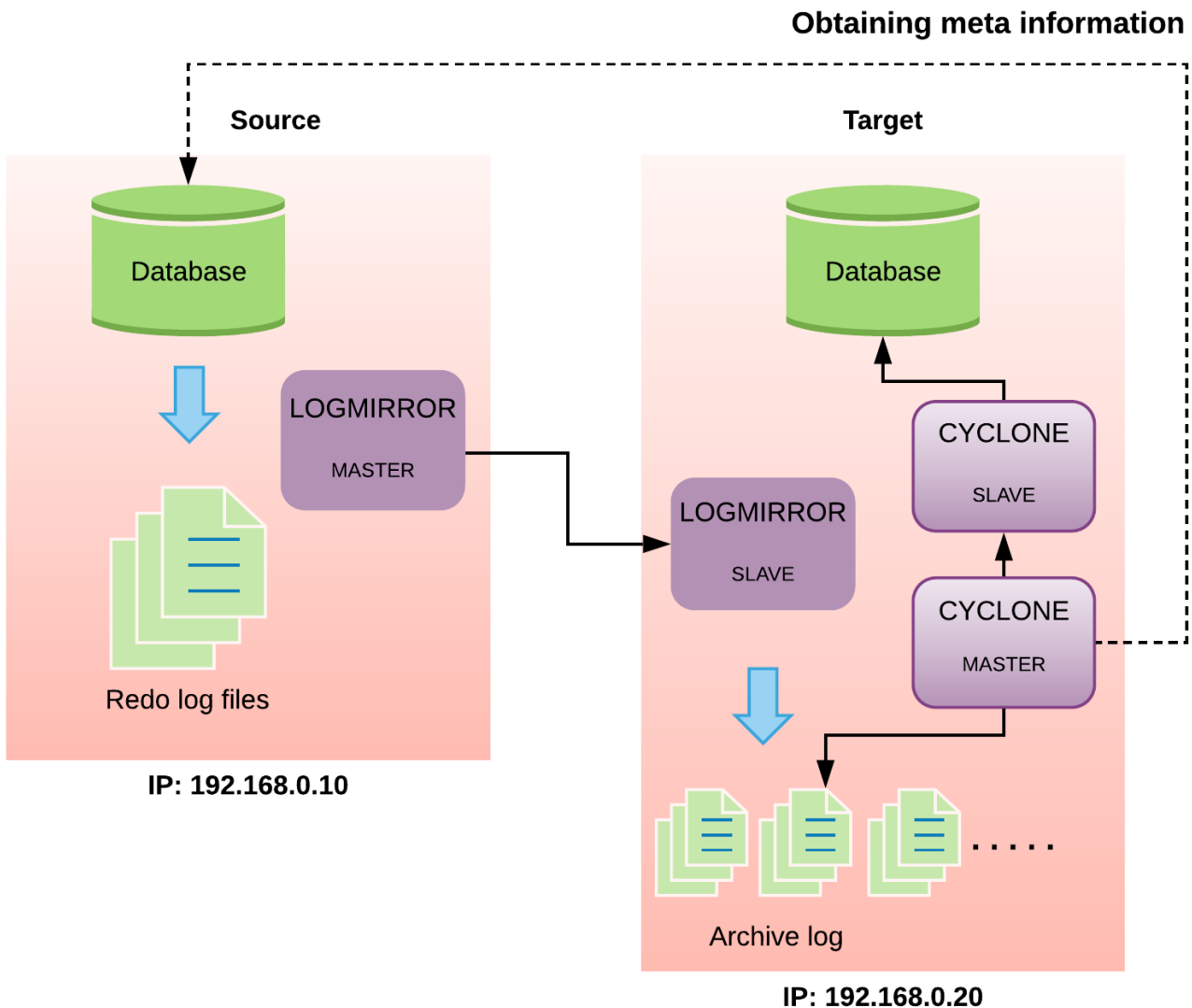

- Device structure
  - The source device which is the original data
    - IP: 192.168.0.10

- GOLDDILOCKS listen port: 22581
  - The table to be replicated: T1, T2
- The remote target device for replication
  - IP: 192.168.0.20
- Two devices executes interworking between LOGMIRROR and CYCLONE for the replication without data loss.
  - Source device: LOGMIRROR (master)
  - Target device: LOGMIRROR (slave) + CYCLONE (master, slave)

## Operating Order

1. Set the configuration of CYCLONE and LOGMIRROR in the original GOLDDILOCKS.
2. Set the configuration of LOGMIRROR MASTER/SLAVE.
3. Execute LOGMIRROR MASTER/SLAVE.
4. Perform LOG FILE SWITCH of the original GOLDDILOCKS for the normal operation of LOGMIRROR.
5. Set the remote GOLDDILOCKS configuration.
6. Set the CYCLONE MASTER/SLAVE configuration.
7. Execute CYCLONE MASTER/SLAVE.

## Configuring CYCLONE and LOGMIRROR in Original GOLDDILOCKS

Refer to the followings.

- CYCLONE configuration: **Requirements**
- LOGMIRROR configuration: **Requirements**

Create the tables T1, T2 for a test after the configuration.

```
gSQL > CREATE TABLE T1( COL1 INTEGER PRIMARY KEY, COL2 VARCHAR(20) );
gSQL > CREATE TABLE T2( COL1 INTEGER PRIMARY KEY, COL2 VARCHAR(20) );
gSQL > COMMIT;
```

## Configuring LOGMIRROR MASTER/SLAVE

- LOGMIRROR MASTER configuration file
  - Storage location: \$GOLDDILOCKS\_DATA/conf/logmirror.master.conf
  - It is the source device.



LOG MIRROR MASTER should be operated on the device in which the original GOLDILOCKS is operated.

- Enter DSN or HOST information. HOST information is entered in the following example.

```
HOST_IP = 192.168.0.10
HOST_PORT = 22581
```

- Use CYCLONE USER created in the previous step.

```
USER_ID = cdc_user
USER_PW = cdc_password
```

- Set the PORT to be used for LOGMIRROR communication.

```
PORT = 21106
```

- LOGMIRROR SLAVE configuration file
  - Storage path: \$GOLDILOCKS\_DATA/conf/logmirror.slave.conf
  - It is the target device.
- Enter the IP address of the device in which LOG MIRROR MASTER is being operated.

```
MASTER_IP = 192.168.0.10
```

- The PORT which is as same as LOGMIRROR MASTER should be entered.

```
PORT = 21106
```

- Enter the absolute path in which the replicated redo log file is to be stored.

```
LOG_PATH = '/data/LogMirrorWAL'
```

## Executing LOGMIRROR MASTER/ SLAVE

- Execute LOGMIRROR MASTER.
  - It should be executed in the source device.

```
logmirror --master --start --conf $GOLDILOCKS_DATA/conf/logmirror.master.conf
```

- Execute LOGMIRROR SLAVE.

- It should be executed in the target device.

```
logmirror --slave --start --conf $GOLDILOCKS_DATA/conf/logmirror.slave.conf
```

## Executing LOGFILE SWITCH of Original GOLDILOCKS for Normal Operation of LOGMIRROR

- LOGFILE SWITCH for starting to record LOGMIRROR file.
  - It should be executed in the source device.

```
gSQL> ALTER SYSTEM SWITCH LOGFILE;
```



When it is executed as above, the redo log file is generated in the path set in the SLAVE device. If the redo log file is not generated, a user should check the directory privilege or check whether the directory is created.

## Configuring Remote GOLDILOCKS

It is required to check the table configuration for the normal operation and replication of GOLDILOCKS operated on the target device, and check the schema information.

The tables T1, T2 are created for test as follows.

```
gSQL > CREATE TABLE T1( COL1 INTEGER PRIMARY KEY, COL2 VARCHAR(20) );
gSQL > CREATE TABLE T2( COL1 INTEGER PRIMARY KEY, COL2 VARCHAR(20) );
gSQL > COMMIT;
```

## Configuring CYCLONE MASTER/ SLAVE

- CYCLONE MASTER configuration file
  - Storage path: \$GOLDILOCKS\_DATA/conf/cyclone.master.conf
  - It is the target device.
- Enter DSN or HOST information of the source device. HOST information is entered in the following example.

```
HOST_IP    = 192.168.0.10
HOST_PORT  = 22581
```

- Use CYCLONE USER

```

USER_ID = cdc_user
USER_PW = cdc_password
GROUP_NAME = GROUP1
{
    PORT = 21102
    CAPTURE_TABLE =
    (
        T1,
        T2
    )
}

```

- CYCLONE SLAVE configuration file
  - Storage path: \$GOLDILOCKS\_DATA/conf/cyclone.slave.conf
  - It is the target device.
- Connect to GOLDILOCKS which is operated in the target device with D/A. (Therefore, DSN and HOST information does not exist.)

```

USER_ID = cdc_user
USER_PW = cdc_password

```

- CYCLONE master is being operated on the same device.

```

MASTER_IP = 192.168.0.20
GROUP_NAME = GROUP1
{

```

- Enter the path set by LogMirror slave.

```

LOG_PATH = '/data/LogMirrorWAL'
    PORT = 21102
    APPLY_TABLE =
    (
        T1 TO T1,
        T2 TO T2
    )
}

```



## Executing CYCLONE MASTER/ SLAVE

- Execute CYCLONE MASTER.
  - It should be executed in the target device when it is connected with D/A.

```
| cyclonet --master --start --conf $GOLDILOCKS_DATA/conf/cyclone.master.conf
```

- Execute CYCLONE SLAVE.
  - It should be executed in the target device when it is connected with D/A.

```
| cyclone --slave --start --conf $GOLDILOCKS_DATA/conf/cyclone.slave.conf
```



**52.**

---

**CYFILE**

## 52.1 CYFILE

CYFILE is a tool which uses Change Data Capture (CDC) method to store the altered data in Comma-Separated Values (CSV) format file.

### Overview

It analyzes the redo log file in real time and stores the transaction executed in the database in CSV format file. It can replicate the transaction file which is recorded in an async way and in near real time to database by using the 3rd party tool, or converts it to another format.

### Operational Features

- It should be operated in the device in which the database is being operated.
- A single file is stored per a group.
- It can be started or terminated in groups.
- Storing CSV file can be set in a unit of table, and one or more tables can be included in a group.
- A table can be included in multiple groups.
- The redo log file should exist in the original database. In other words, DATA\_STORE\_MODE should be operated in TDS.
- SUPPLEMENTAL LOGGING should exist in the original database.
  - SUPPLEMENTAL LOGGING adds an additional information to the redo log file.
- The database should be operated in ARCHIVE LOG mode.
- Its process is independent from that of GOLDILOCKS, so terminating the tool does not affect GOLDILOCKS.

### Operational Restrictions

- The table to capture should have PRIMARY KEY.
- It captures the committed transaction only. Therefore, it is unable to see the contents in CSV file before commitment
- It does not support the primary key update.
  - When the primary key value is updated, then the table is given up and is not captured any more.
- The table to capture can not use a column which has Generated Always As Identity property.
- When Data Definition Language (DDL) was performed on the table to capture, then it is given up.

- It does not affect the replication of another table.
- It is same for the truncate table.
- Only the table which was given up with --reset TABLE\_NAME among give up tables can be reset.
- The table stored in the trash bin can not be a target to capture.
- It does not support long varchar, long varbinary.



The server property **DISABLE\_DDL\_CDC\_GIVEUP** can disable the DDL statement which causes the replication give up to avoid user created errors. Also, the server property **DISABLE\_UPDATE\_PRIMARY\_KEY\_CDC\_GIVEUP** can disable primary key update.

## Others

It stores the file at the following moment.

- It stores the file from the moment when TX occurs at the first running.
- It stores the file in succession from the terminated moment even when run it again after it is terminated during the operation.
- Use --reset option to give up the old file and restart from the current time.

## 52.2 Requirements

It is required to perform GOLDILOCKS preparations, user registration and privilege settings.

### GOLDILOCKS Requirements

The followings should be set in GOLDILOCKS before starting CYFILE.

#### SUPPLEMENTAL LOGGING

SUPPLEMENTAL LOGGING stores an additional information together in the redo log file. The database should be restarted to change the settings of operating database, but restarting is not needed when setting SUPPLEMENTAL LOGGING only in the specific table.

#### Setting SUPPLEMENTAL LOGGING in Database

- When setting SUPPLEMENTAL LOGGING as GOLDILOCKS property, SUPPLEMENTAL LOGGING is recorded for all tables.
- Restart GOLDILOCKS.
- Add or update the contents in the property file.
  - Property file: goldilocks.properties.conf
  - Property setting: SUPPLEMENTAL LOG\_DATA\_PRIMARY\_KEY = YES

#### Setting SUPPLEMENTAL LOGGING in Specific Table Participating in the Replication

```
<add table supplemental log statement> ::=  
ALTER TABLE table_name  
    ADD SUPPLEMENTAL LOG DATA ( PRIMARY KEY ) COLUMNS  
;
```

#### ARCHIVE LOG

GOLDILOCKS reuses the redo log files recursively. When GOLDILOCKS reuses the redo log file being processed by CYFILE, then CYFILE does not proceed and is terminated. GOLDILOCKS should be operated in ARCHIVE LOG mode to ensure the continuous replication operation.

## Changing Database in Operation to ARCHIVE LOG Mode

- Restart GOLDILOCKS.
- After database is shutdown, connect with sysdba and change it to ARCHIVE LOG mode in MOUNT phase.

```
gSQL> \startup mount
Startup success
gSQL> alter database archivelog;
Database altered.
```

## Setting ARCHIVE LOG Mode When Creating Database

- Update the property file before creating the database.
  - Property file: goldilocks.properties.conf
  - Property setting: ARCHIVELOG\_MODE = 1



The path in which ARCHIVE LOG file is stored can be viewed and updated with 'ARCHIVELOG\_DIR'.

## DATA\_STORE\_MODE

CYFILE performs the replication by reading the redo log files of GOLDILOCKS. Therefore, GOLDILOCKS should be operated in Transactional Data Store (TDS) mode.

## Changing DATA\_STORE\_MODE

- Restart the database.
- Add or update the corresponding information in the property file.
  - Property file: goldilocks.properties.conf
  - Property setting: DATA\_STORE\_MODE = 2



If the value of DATA\_STORE\_MODE is 1, it indicates Concurrent Data Store (CDS), and if it is 2, it indicates Transactional Data Store (TDS).

## Registering User and Setting Privileges

CYFILE retrieves and manipulates the required information during the operation. The user operating CYFILE and the proper privileges for the user are required.

### Creating Database User

A specific user should be added to operate CYFILE.

```
<user definition> ::=  
    CREATE USER user_identifier IDENTIFIED BY password  
    [ DEFAULT TABLESPACE tablespace_name ]  
    [ TEMPORARY TABLESPACE tablespace_name ]  
    [ INDEX TABLESPACE {tablespace_name|NULL} ]  
    [ <schema clause> ]  
    ;  
<schema clause> ::=  
    WITH SCHEMA [schema_name]  
    | WITHOUT SCHEMA
```

The following is an example of creating the user `cyfile_user` and the password `cyfile_password`.

```
gSQL> CREATE USER cyfile_user IDENTIFIED BY cyfile_password;
```

### Database Privileges

#### Granting User Access Privilege

The following is an example for granting the access privilege to `cyfile_user`.

```
gSQL> GRANT CREATE SESSION ON DATABASE TO cyfile_user;
```



## 52.3 Configuration

### Configuration File

When performing CYFILE, the information and options required for operating are set by using the configuration file.

- When a specific configuration file is not set by using the `--conf` option, `$GOLDILOCKS_DATA/conf/cyfile.conf` file is read.

**Table 52-1** Configuration file options

Name	Description
DSN	It sets Data Source Name.
GROUP_NAME	It sets the group name.
HOST_IP	It sets the host IP address of which GOLDILOCKS operates.
HOST_PORT	It sets the host port of which GOLDILOCKS operates.
USER_ID	It sets the user name.
USER_PW	It sets the user password.
USER_ENCRYPT_PW	It sets the encrypted password for a user.
CAPTURE_TABLE	It sets the table to be replicated.
PROTOCOL	It sets the connection type which is to be connected to GOLDILOCKS. (DA or TCP)
READ_LOG_BLOCK_COUNT	It sets the amount of data to be read at a time when operating CAPTURE.
TRANS_SORT_AREA_SIZE	It sets the size of the BUFFER to be allocated to CAPTURE.
TRANS_FILE_PATH	It sets the location in which the temporarily generated file is to be stored when operating CAPTURE.
LOG_CAPTURE_INTERVAL_1	It sets the execution cycle of capture. If the value is not changed after executing 10 times with that value, then it is converted to the value of LOG_CAPTURE_INTERVAL_2 and performs capture. (The default value is 0.2 seconds.)
LOG_CAPTURE_INTERVAL_2	It sets the execution cycle of capture. If the value is not changed after executing with the value of LOG_CAPTURE_INTERVAL_1, then it sets the execution cycle of capture. (The default value is 1 second.)
DATA_FILE_PATH	It sets the path to store CSV file. (It should be an absolute path.)
DATA_FILE_PREFIX	It sets the prefix of CSV file name.
DATA_FILE_SIZE	It sets the maximum size of CSV file. (It is an approximate size and it is not always set to the specified value.)
UPDATE_BEFORE_VALUE	It sets whether to store the value before the update in CSV when processing update SQL. (The default value is 0.)

# Configuration Options

## DSN

- It sets the data source name required for the access to GOLDILOCKS.
- It can be set in master and slave.
- The default value is GOLDILOCKS.
- Settings applied to all groups

```
DSN=GOLDILOCKS
```

- Settings applied to a specific group

```
GROUP_NAME = testGROUP
{
    DSN=GOLDILOCKS
    ....
    ....
}
```

## GROUP\_NAME

- It is necessary for distinguishing the CYFILE operation within the equipment and it is a unit of generating the operation process.
- It is the delimiter of when starting or terminating CYFILE in group unit.
- After it is set, it should not be changed. If changed, it is regarded as a new group.
- GROUP\_NAME should be unique in the same equipment.
- The braces {} should be used.

```
GROUP_NAME = testGROUP
{
    ....
    ....
}
```

## HOST\_IP

- It sets the IP address of GOLDILOCKS in which CYFILE accesses to.
- It is valid only when PROTOCOL is set to TCP.

- Settings applied to all groups

```
HOST_IP = 127.0.0.1
```

- Settings applied to a specific group

```
GROUP_NAME = testGROUP
{
    HOST_IP = 127.0.0.1
    ....
    ....
}
```

## HOST\_PORT

- It sets port of GOLDDILOCKS in which CYFILE accesses to.
- It should be set together with HOST\_IP.

- Settings applied to all groups

```
HOST_PORT = 22531
```

- Settings applied to a specific group

```
GROUP_NAME = testGROUP
{
    HOST_PORT = 22531
    ....
    ....
}
```

## USER\_ID

It sets the user ID required for the access to GOLDDILOCKS.

- Settings applied to all groups

```
USER_ID = testID
```

- Settings applied to a specific group

```
GROUP_NAME = testGROUP
{
    USER_ID = testID
    ....
    ....
}
```

## USER\_PW

It sets the user password required for the access to GOLDILOCKS.

- Settings applied to all groups

```
USER_PW = testPW
```

- Settings applied to a specific group

```
GROUP_NAME = testGROUP
{
    USER_PW = testPW
    ....
    ....
}
```

## USER\_ENCRYPT\_PW

- It sets the user password which is required for the access to GOLDILOCKS by encrypting.
- It is used instead of USER\_PW.
- Encrypted user password is created by `[cyfile --encrypt user password --key the key to be encrypted]`.
- If this value is used, then `--key` option should be used when executing cyfile. (In this case, the key value as same as that created with `--encrypt` should be used.
- Settings applied to all groups

```
USER_ENCRYPT_PW = 't33KImiqvhqNyfN+uZmFrw=='
```

- Settings applied to a specific group

```
GROUP_NAME = testGROUP
{
    USER_ENCRYPT_PW = 't33KImiqvhqNyfN+uZmFrw=='
    ....
}
```

```

    ....
}

```

## CAPTURE\_TABLE

- It sets the table to capture.
  - It is set in *schema name.table name* format.
- It can be set only within a group.
- When specifying several tables, the parentheses ( ) should be used.
- The table stored in the recycle bin can not be set to be replicated.

```

GROUP_NAME = testGROUP
{
    CAPTURE_TABLE =
    (
        testSchema1.testTable1,
        testSchema1.testTable2,
        testSchema2.testTable1
    )
}

```

## PROTOCOL

- It sets the type to connect to GOLDDILOCKS in operation.
  - It can be set to DA or TCP.
  - If PROTOCOL is set to DA, neither HOST\_IP nor is HOST\_PORT used when accessing to GOLDDILOCKS.
  - The default value is DA.
- Settings applied to all groups

```

PROTOCOL = DA

```

- Settings applied to a specific group

```

GROUP_NAME = testGROUP
{
    PROTOCOL = DA
    ....
    ....
}

```

## READ\_LOG\_BLOCK\_COUNT

- It sets the number of the log blocks to be read at a time when capturing redo log file.
- The size of a log block is 512 bytes.
- The default value is 40960, and the actual read size is 20 MBytes.
  - The minimum value is 100.
- Settings applied to all groups

```
READ_LOG_BLOCK_COUNT = 1024
```

- Settings applied to a specific group

```
GROUP_NAME = testGROUP
{
    READ_LOG_BLOCK_COUNT = 1024
    ....
    ....
}
```

## TRANS\_SORT\_AREA\_SIZE

- It sets the memory space required for capturing the redo log files.
- The unit is MB (megabytes).
- The default value is 500 MB.
  - The minimum value is 10 MB.
- If the value is set too small, the performance becomes poor.
- Settings applied to all groups

```
TRANS_SORT_AREA_SIZE = 300
```

- Settings applied to a specific group

```
GROUP_NAME = testGROUP
{
    TRANS_SORT_AREA_SIZE = 300
    ....
    ....
}
```

## TRANS\_FILE\_PATH

- If a space bigger than TRANS\_SORT\_AREA\_SIZE is required, the temporary file is created. It sets the path in which the temporary file is to be stored.
  - The absolute path should be used.
  - The path should be specified by using single quote (').
- Settings applied to all groups

```
TRANS_FILE_PATH = '/data/TmpTrans'
```

- Settings applied to a specific group

```
GROUP_NAME = testGROUP
{
    TRANS_FILE_PATH = '/data/TmpTrans'
    ....
    ....
}
```

## LOG\_CAPTURE\_INTERVAL\_1

- It sets the execution cycle of capture in millisecond.
- It is used to quickly detect the changes of the redo log file.
- If the value of redo log file is not changed after executing 10 times with that value, then it is converted to the value of LOG\_CAPTURE\_INTERVAL\_2 and performs capture.
- The default value is 200 (0.2 seconds), and the unit is millisecond.
- Settings applied to all groups

```
LOG_CAPTURE_INTERVAL_1 = 200
```

- Settings applied to a specific group

```
GROUP_NAME = testGROUP
{
    LOG_CAPTURE_INTERVAL_1 = 200
    ....
    ....
}
```

## LOG\_CAPTURE\_INTERVAL\_2

- It sets the execution cycle of capture in millisecond.
- It is used to quickly detect the changes of the redo log file.
- If the value of redo log file is not changed after executing 10 times with the value of LOG\_CAPTURE\_INTERVAL\_1, then it is converted to the corresponding value and performs capture.
- The default value is 1000(1 second), and the unit is millisecond.
- Settings applied to all groups

```
LOG_CAPTURE_INTERVAL_2 = 1000
```

- Settings applied to a specific group

```
GROUP_NAME = testGROUP
{
    LOG_CAPTURE_INTERVAL_2 = 1000
    ....
    ....
}
```

## DATA\_FILE\_PATH

- It sets the path to store CSV file.
  - The absolute path should be used.
  - The path should be specified by using single quote (').
- If it is not set, then the location in which cyfile is run becomes the default path.
- The following files are stored.
  - Data file (.dat)
  - Control file (.ctl)
  - Control mirror file (.ctl\_0)
- Settings applied to all groups

```
DATA_FILE_PATH = '/home/goldilocks/dat'
```

- Settings applied to a specific group

```
GROUP_NAME = testGROUP
{
    DATA_FILE_PATH = '/home/goldilocks/dat'
    ....
}
```



```

    ....
}

```

## DATA\_FILE\_PREFIX

- It sets the prefix of the name to be used when storing CSV file.
- If it is not set, then the prefix is 'cyfile'.
- Settings applied to all groups

```
DATA_FILE_PREFIX = 'SET_PREFIX'
```

- Settings applied to a specific group

```

GROUP_NAME = testGROUP
{
    DATA_FILE_PREFIX = 'SET_PREFIX'
    ....
    ....
}

```

## DATA\_FILE\_SIZE

- It sets the approximate maximum size of CSV file.
  - The size can be maximum 16 M bigger than the input size.
- The input value is in megabytes.
  - Input 1024 for 1 giga.
- The default value is 100 M.
  - The minimum value is 30 M and the maximum value is 4096 M (4G).
- Settings applied to all groups

```
DATA_FILE_SIZE = 200
```

- Settings applied to a specific group

```

GROUP_NAME = testGROUP
{
    DATA_FILE_SIZE = 200
    ....
    ....
}

```

```
}  
}
```

## UPDATE\_BEFORE\_VALUE

- It sets whether to store the value before the update in CSV when processing UPDATE SQL.
  - Set it to 1 to preserve the previous value.
  - Set it to 0 not to preserve the previous value.
- The default value is 0 which does not preserve the previous value.
- Settings applied to all groups

```
UPDATE_BEFORE_VALUE = 1
```

- Settings applied to a specific group

```
GROUP_NAME = testGROUP  
{  
    UPDATE_BEFORE_VALUE = 1  
    ....  
    ....  
}
```

## 52.4 Operating

CYFILE can be operated in D/A or C/S environment of GOLDDILOCKS.

CONFIG file or PROTOCOL configuration of ODBC.INI should be used according to the environments as follows. CONFIG configuration takes precedence over ODBC.INI configuration.

**Table 52-2** CONFIG, ODBC.INI

Configuration	Description
PROTOCOL=DA	It is used in D/A environment. (Default)
PROTOCOL=TCP	It is used in C/S environment.

The running contents during the operation can be viewed through trace log.

Item	File
Cyfile	\$GOLDDILOCKS_DATA/trc/cyfile_(groupName).trc

## Executing Option

CYFILE should be used with the following options at run-time.

**Table 52-3** Executing options

Option	Description	Remarks
--start   -s	It starts CYFILE.	-
--stop   -t	It stops CYFILE.	-
--status   -u	It displays the status of CYFILE.	-
--conf   -c	It sets the path of configuration file which is required when executing CYFILE.	It is input in --conf CONFIG_FILE format. It should be used together with --start. If it is not explicitly set, \$GOLDDILOCKS_DATA/conf/cyfile.conf is used.
--silent   -i	It sets not to output messages.	-
--reset   -r	It resets the information about capture.	It is input in --reset TABLE_NAME or --reset all format. It should be described within a single quote (') when resetting multiple tables.
--group   -g	It sets a specific group.	It is input in --group GROUP_NAME format.
--help   -h	It outputs the help message.	-
--encrypt   -e	It encrypts the user password with the given key.	-

Option	Description	Remarks
--key   -k	It sets the encryption key when performing the --encrypt option. If USER_ENCRYPT_PW is used in the config, it sets the decryption key.	-
--info   -o	It displays the status of currently running table.	It should be used together with --group.

- It executes all groups by using the default environment file.

```
prompt> cyfile --start
```

- It stops all groups.

```
prompt> cyfile --stop
```

- It executes TEST\_GROUP group only.

```
prompt> cyfile --start --group TEST_GROUP
```

- It stops only TEST\_GROUP group among operating groups.

```
prompt> cyfile --stop --group TEST_GROUP
```

- The encrypts GOLDILOCKS user password.

```
prompt> cyfile --encrypt test --key 1234
Cyfile Encrypted Passwd : '73LsLxss6lk='
```

- USER\_ENCRYPT\_PW is set in the config.

```
prompt> cyfile --start --key 1234
```

- It deletes the existing operational information and newly starts it.

```
prompt> cyfile --start --reset all
```

- It deletes the existing operational information of the tables T1, T2, and starts it newly from the current point.

```
prompt> cyfile --start --reset 'T1, T2'
```

- It displays the current operational information per each table.

```
prompt> cyfile --info --group GROUP1
```

```
=====
GROUP NAME = GROUP1
=====
```

```
SCHEMA NAME      : PUBLIC
TABLE NAME       : TEST_TABLE_02 (ACTIVE (CAPTURE-START-LSN:217368))
PHYSICAL ID      : 36313948487680
STATUS           : ONLINE
=====
```

```
SCHEMA NAME      : PUBLIC
TABLE NAME       : TEST_TABLE_01 (ACTIVE (CAPTURE-START-LSN:217602))
PHYSICAL ID      : 36322538422272
STATUS           : ONLINE
=====
```

```
TOTAL COUNT : 2
GIVE-UP COUNT : 0
NODE        : TRUST
=====
```

## 52.5 Files

CYFILE stores the information about insert/ update/ delete and capture table in CSV format. It uses async method but it is operated in near real-time.

There are two types of file for storage when operating CYFILE, which are the data file and the control file. The data file stores the transaction in CSV format and the control file stores the storage information about the data file. The control file creates and operates the mirror file in preparation for data loss or damage.

**Table 52-4** CYFILE

File	Name information
Data file	It is stored in CSV format, and the extension is dat.
Control file	The extension is ctl. The extension of mirror file is ctl_0.

### Data File

It records I/D/U information which is performed in transaction unit and in CSV format, the information about the column of the table participating in capture and give up table information. Those files are not automatically deleted unless a user deletes them.

### File Name

The location and name of the stored file is determined by `DATA_FILE_PREFIX`, `DATA_FILE_PATH`. The extension is `.dat` and it is created according to the following rules.

- Data file format
  - `(DATA_FILE_PREFIX).(GROUP_NAME).(FILE_SEQUENCE).dat`
    - e.g. `CYFILE.GROUP1_1.dat`, `CYFILE.GROUP1_2.dat`

When a new file is created because the data file size becomes bigger than `DATA_FILE_SIZE`, then the value is determined by adding 1 to `FILE_SEQUENCE`.



`DATA_FILE_PATH`, `DATA_FILE_PREFIX` should not be changed after it starts the operation.

## INSERT Storage Format

- In case of INSERT, T standing for table and I standing for insert are described as delimiters, and the schema name and the table name of the table in which the insert is performed are described.
- The actual data is a pair of the column name and the column value, and the information about the entire column is described in it.

Figure 1 INSERT expression

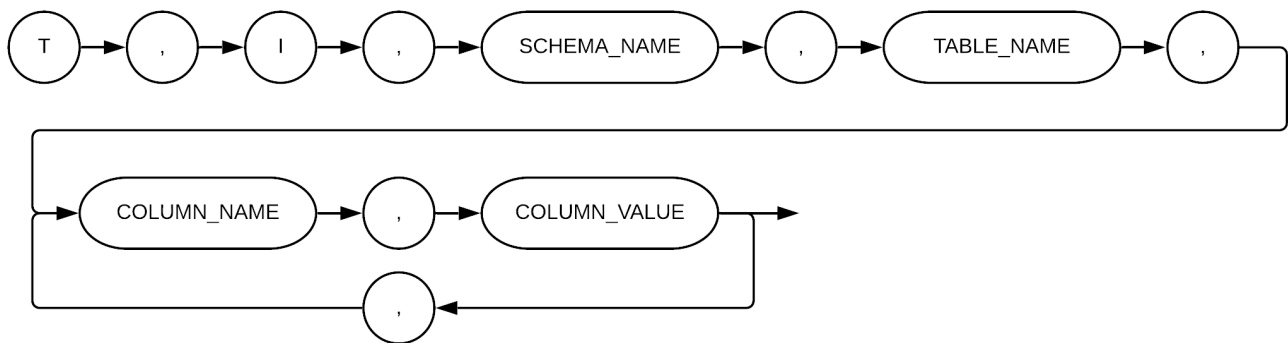

Query: INSERT INTO PUBLIC.TEST(C1, C2, C3) VALUES( 1, 2, 'ABC' );

CSV storage: T, I, "PUBLIC", "TEST", "C1", "1", "C2", "2", "C3", "ABC"

Query: INSERT INTO PUBLIC.TEST(C1, C3) VALUES( 1, ABC );

CSV storage: T, I, "PUBLIC", "TEST", "C1", "1", "C2", NULL, "C3", "ABC"

## DELETE Storage Format

- In case of DELETE, T standing for table and D standing for delete are described as delimiters, and the schema name and the table name of the table in which the delete is performed are described.
- The primary key information of the deleted data is described, and if it is a composite key, then the primary key count becomes 2 or bigger and repeatedly described as many times as the count.

Figure 2 DELETE expression

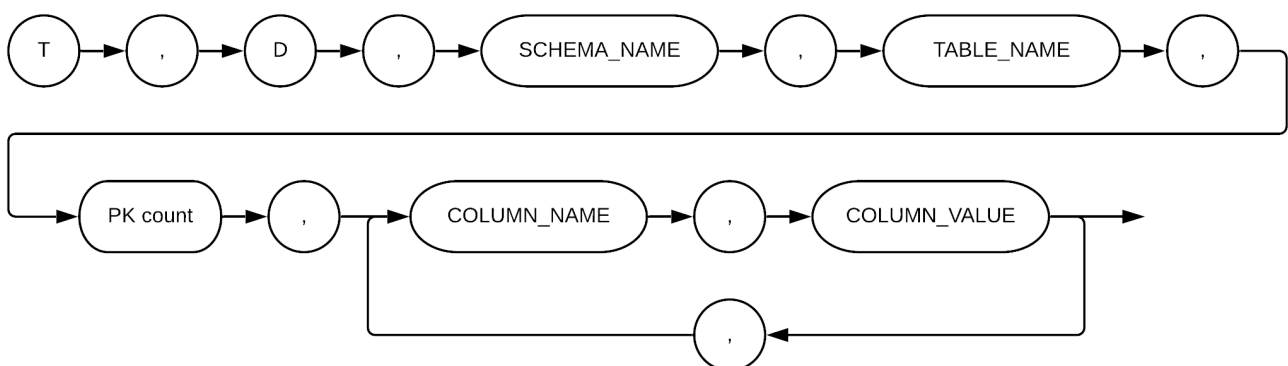

Sample: When there is one primary key

Query: DELETE FROM PUBLIC.TEST WHERE C1=1;

CSV storage: T, D, "PUBLIC", "TEST", 1, "C1", "1"

Sample: When there are two or more primary keys

Query: DELETE FROM PUBLIC.TEST WHERE C1=1 AND C2=2;

CSV storage: T, D, "PUBLIC", "TEST", 2, "C1", "1", "C2", "2"

## UPDATE Storage Format

- In case of UPDATE, T standing for table and U standing for update are described as delimiters, and the schema name and the table name of the table in which the update is performed are described.
- The primary key information of the updated data is described, and if it is a composite key, then the primary key count becomes 2 or bigger and repeatedly described as many times as the count.
- The information of actually updated column is repeatedly described.
  - When UPDATE\_BEFORE\_VALUE is set to 1, the value before the update is described together.

Figure 3 UPDATE expression

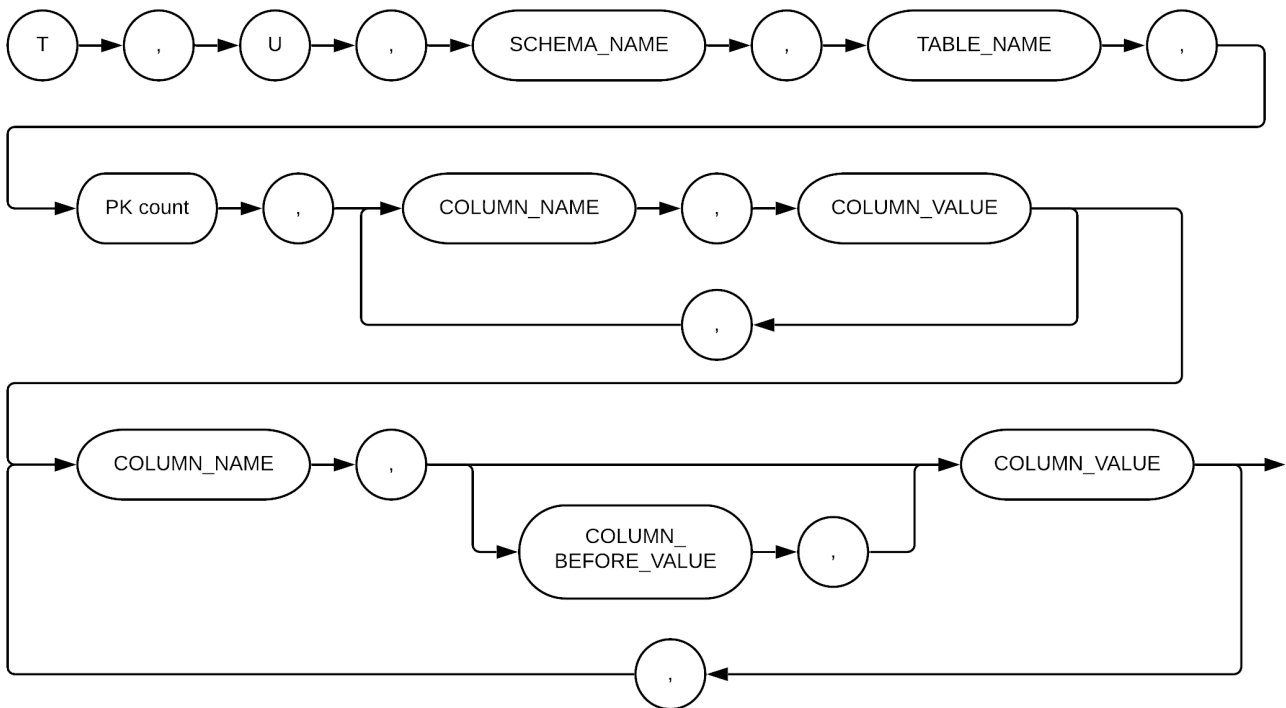

Sample: C2 value in the record whose primary key is only c1 is changed from 1 to 2.

Query: UPDATE PUBLIC.TEST SET C2=2 WHERE C1=1;

\* When UPDATE\_BEFORE\_VALUE is not set

CSV storage: T, U, "PUBLIC", "TEST", 1, "C1", "1", "C2", "2"

\* When UPDATE\_BEFORE\_VALUE is set

CSV storage: T, U, "PUBLIC", "TEST", 1, "C1", "1", "C2", "1", "2"



Sample: Change C3 value from 'ABC' to 'BCD', and C4 value from 3 to 4 in the record whose primary keys are C1, C2.

Query: UPDATE PUBLIC.TEST SET C3='BCD', C4=4 WHERE C1=1 AND C2=2;

\* When UPDATE\_BEFORE\_VALUE is not set

CSV storage: T, U, "PUBLIC", "TEST", 2, "C1", "1", "C2", "2", "C3", "BCD", "C4", "4"

\* When UPDATE\_BEFORE\_VALUE is set

CSV storage: T, U, "PUBLIC", "TEST", 2, "C1", "1", "C2", "2", "C3", "ABC", "BCD", "C4", "3", "4"

## Transaction Information

- begin stands for the beginning of the transaction.
  - Additional information: Transaction ID
    - For cluster environment (Global transaction ID)
- Transaction commit
  - Additional information: Commit SCN (System Change Number)
    - For cluster environment (Global SCN)

Figure 4 Transaction begin expression

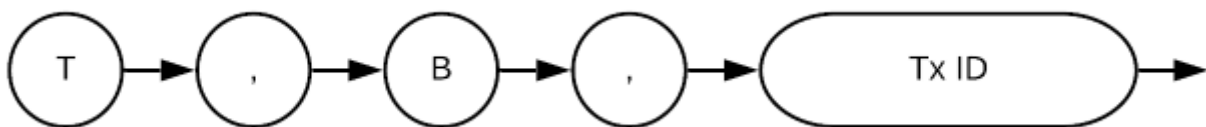
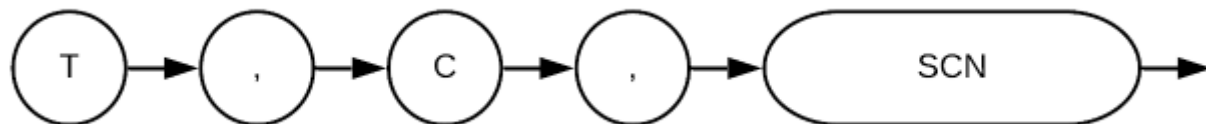

Figure 5 Transaction commit expression



## Table Information

- It records the information about the table and column to replicate.
  - The information about N columns per one table information are consecutively recorded.
  - It is repeatedly recorded as many times as the number of tables to replicate.
- It is recorded only once.
  - It is recorded for the first time when starting the program.
  - It is not recorded when restarting the program.
- When resetting or the table is added, then the information is recorded again.
- It records the information about the give up table.
  - The give up table is not captured any more.

- It can make the table to participate in the replication again by using reset option.

**Figure 6** Table expression

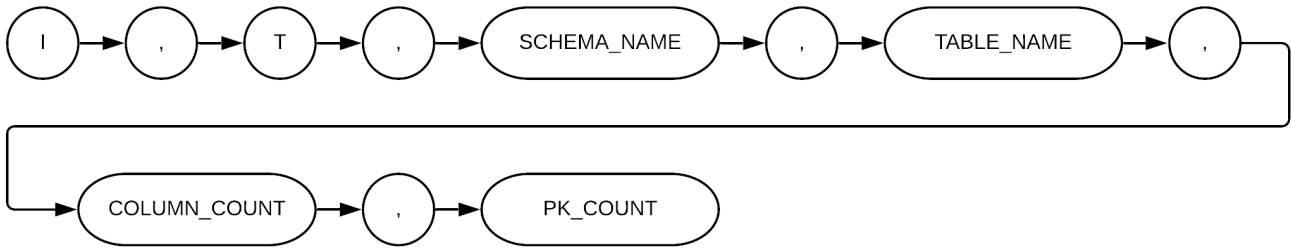

**Figure 7** COLUMN expression

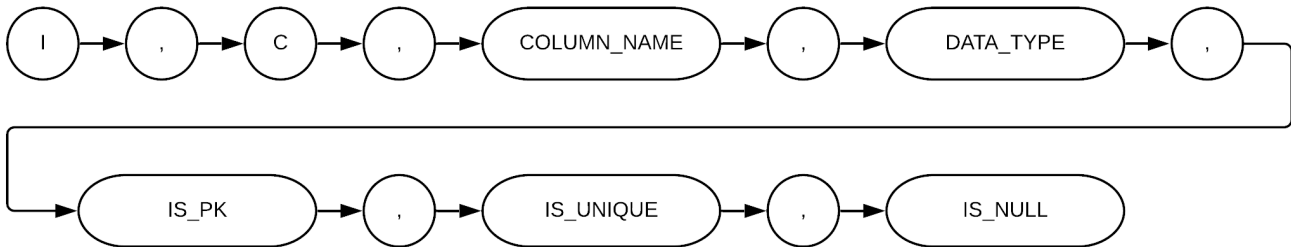

- Information about table TEST, TEST2

```

I,T,"PUBLIC", "TEST", 3, 1
I,C,"C1", "NUMBER(10,0)", 1, 0, 0
I,C,"C2", "VARCHAR(20)", 0, 0, 1
I,C,"C3", "VARCHAR(10)", 0, 0, 1
I,T,"PUBLIC", "TEST2", 2, 1
I,C,"C1", "NUMBER(10,0)", 1, 0, 0
I,C,"C2", "VARCHAR(20)", 0, 0, 1
  
```

## Meta Information

- The following information is recorded at the front line when creating the data file.
  - Version information
    - 8 byte version information
    - It is used to check the compatibility of the data file.
  - Date information
    - The point of when the file is created is recorded.
  - Control file path
    - It records the path of the control file in which the information of the data file is recorded.

Figure 8 Version expression

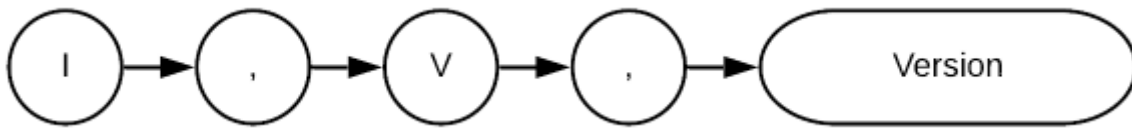

Figure 9 Date information expression



Figure 10 Control file information expression



```
I,V, 00000000
```

```
I,D,"2022-12-24 00:01:00.000000"
```

```
I,M, "/home/cyfile/ctrl_file/cyfile.GROUP1.ctl"
```

## Command Information

- EOF is recorded at the end of the existing file when the data file is stored in a new file because its size exceeds the maximum size.
  - Process it by reading the following file when that information is recorded.

Figure 11 EOF expression

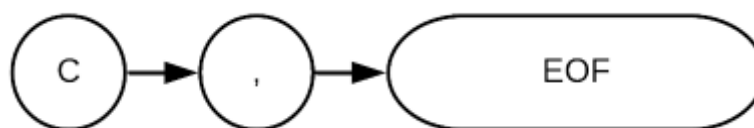

## Control File

- It records the valid information about the data file.
  - The data file is restarted and restored, so the stored value is not always valid.
  - If the information in the control file is used, then the value is always valid even when it is restarted and restored.

- The control file size is 512 Bytes.
  - It should be used by offsetting the data or defining the structure.

```
typedef struct ctrlFileStr
{
    char          mVersion[8];
    unsigned int  mFileInfoCrc; //mFileSeq + mFileOffset CRC
    unsigned int  mDummy;       //Not Used.

    signed long   mFileSeq;
    signed long   mFileOffset; //Valid Offset
} ctrlFileStr;
```

- mVersion: Checking the compatibility
- mFileInfoCRC: CRC information of mFileSeq and mFileOffset
- mDummy: It is not used.
- mFileSeq: The current data file number
- mFileSeq: The valid location in the data file number including mFileSeq (Offset)

# Appendix A.

---

## Error Codes

GOLDILOCKS provides user error codes as follows. The error messages can be viewed with `V$ERROR_CODE`.

## A.1 OS Related Error

- Error code: GOLDILOCKS-specific error code
- SQLSTATE: SQL standard state code
- Message: Error message

**Table A-1** OS related error

Error code	SQLSTATE	Message
11000	HY000	Invalid argument
11001	HY000	The operation was incomplete although some processing was performed and the results are partially valid
11002	HY000	Permission denied '%s'
11003	HY000	Standard Layer has encountered the end of the file
11004	HY000	Unable to duplicate a file
11005	HY000	File Lock Error
11006	HY000	File Unlock Error
11007	HY000	Unable to open the file '%s'
11008	HY000	Unable to close the file
11009	HY000	Unable to remove the file
11010	HY000	Unable to link the file
11011	HY000	Unable to read the file
11012	HY000	Unable to write the file
11013	HY000	Unable to sync the file
11014	HY000	Unable to seek the file
11015	HY000	Unable to truncate the file
11016	HY000	Unable to get the status of the file
11017	HY000	Unable to create a pipe
11018	HY000	Unable to wait for the given process
11019	HY000	Insufficient resource
11020	HY000	Unable to send signal to given process
11021	HY000	Unable to set a signal handler
11022	HY000	Unable to block a signal
11023	HY000	Unable to set thread attribute
11024	HY000	Unable to create a thread
11025	HY000	Unable to join with a terminated thread
11026	HY000	Unable to set thread once code
11027	HY000	Truncation occurred on I/O operation
11028	HY000	The given name(%s) is too long
11029	HY000	shared memory segment exists
11030	HY000	Unable to allocate a shared memory segment

Error code	SQLSTATE	Message
11031	HY000	Unable to attach the shared memory segment
11032	HY000	Unable to detach the shared memory segment
11033	HY000	Unable to destroy the shared memory segment
11034	HY000	Unable to create a semaphore
11035	HY000	Unable to acquire the given semaphore
11036	HY000	Unable to release the given semaphore
11037	HY000	Unable to destroy the given semaphore
11038	HY000	The given object was busy
11039	HY000	Operation timed out
11040	HY000	No such object (%s)
11041	HY000	Two objects do not match
11042	HY000	Not enough memory
11043	HY000	File system is full
11044	HY000	Unable to execute the program
11045	HY000	not supported function
11046	HY000	given buffer does not have enough space
11047	HY000	invalid network address
11048	HY000	sendto() system call returned failure
11049	HY000	recvfrom() system call returned failure
11050	HY000	fail to get address from socket with getsockname()
11051	HY000	fail to get peer address from socket with getpeername()
11052	HY000	fail to manipulate file descriptor with fcntl()
11053	HY000	fail to manipulate socket descriptor with setsockopt()
11054	HY000	not implemented feature
11055	HY000	fail to manipulate device parameters of special file with ioctl()
11056	HY000	fail to get hostname
11057	HY000	fail to close a socket
11058	HY000	fail to shutdown a socket
11059	HY000	fail to create a socket
11060	HY000	fail to get property of a file descriptor
11061	HY000	fail to set property of a file descriptor
11062	HY000	fail to bind a socket to address
11063	HY000	fail to listen on a socket
11064	HY000	fail to accept a connection request with a socket
11065	HY000	system call was interrupted by a signal
11066	HY000	fail to get options of a socket
11067	HY000	fail to connect to an host with a socket
11068	HY000	fail to wait for some file descriptors with poll()
11069	HY000	internal error
11070	HY000	sendmsg() system call returned failure

Error code	SQLSTATE	Message
11071	HY000	recvmsg() system call returned failure
11072	HY000	socketpair() system call returned failure
11073	HY000	converted value is out of range (overflow or underflow)
11074	HY000	given string is not number
11075	HY000	not a valid file descriptor
11076	HY000	resource temporarily unavailable
11077	HY000	given address is already in use
11078	HY000	fail to initialize communication context
11079	HY000	fail to finalize communication context
11080	HY000	fail to connect communication context
11081	HY000	fail to poll communication context
11082	HY000	fail to write packet through communication context
11083	HY000	fail to read packet through communication context
11084	HY000	fail to send descriptor through communication context
11085	HY000	fail to receive descriptor through communication context
11086	HY000	fail to get current file path
11087	HY000	fail to open library (%s)
11088	HY000	fail to close library
11089	HY000	fail to get symbol address (%s)
11090	HY000	not supported query
11091	HY000	fail to check file (%s)
11092	HY000	input is too long
11093	HY000	system call error (function : %s, error no : %d)
11094	HY000	divide zero
11095	HY000	Unable to open a semaphore
11096	HY000	Unable to close the given semaphore
11097	HY000	Unable to unlink the given semaphore
11098	HY000	permission denied - '%s'
11099	HY000	not supported os
11100	HY000	Environment Variable "%s" is not defined.
11101	HY000	License file(%s) is not exist
11102	HY000	License is out of date. License is valid after %4d-%02d-%02d
11103	HY000	License date is expired. License is expired in %4d-%02d-%02d
11104	HY000	License core count mismatch.
11105	HY000	License key is corrupted.
11106	HY000	License host name mismatch.
11107	HY000	failed to set thread affinity.
11108	HY000	failed to create timer.
11109	HY000	failed to set timer.
11110	HY000	failed to destroy timer.



Error code	SQLSTATE	Message
11111	HY000	address is not given.
11112	HY000	Unable to access the message queue.
11113	HY000	A message queue exists.
11114	HY000	Unable to create a message queue.
11115	HY000	The message queue was removed.
11116	HY000	Unable to destroy the message queue.
11117	HY000	Unable to send message.
11118	HY000	Unable to receive message.
11119	HY000	No message was available in the message queue.
11120	HY000	fail to get property of a file status
11121	HY000	fail to set property of a file status
11122	HY000	infiniband ibv/rdma interface returned error
11123	HY000	no infiniband device was found
11124	HY000	cannot find specified infiniband device
11125	HY000	cannot find suitable Memory Region for specified ptr and size
11126	HY000	fail to get semaphore value
11127	HY000	fail to control pollset
11128	HY000	fail to create pollset
11129	HY000	overflow fd
11130	HY000	invalid INI file format
11131	HY000	path '%s' does not exist
11132	HY000	Unable to get maximum undo semaphores per array
11133	HY000	Unable to create a undo semaphore
11134	HY000	Unable to bind the given undo semaphore
11135	HY000	Unable to unbind the given undo semaphore
11136	HY000	Unable to get the given undo semaphore state
11137	HY000	Unable to destroy the given undo semaphore
11138	HY000	Unable to suspend asynchronous io
11139	HY000	Unable to control the shared memory segment
11140	HY000	Unable to detach a thread
11141	O8S01	Communication link failure
11142	HY000	No such process
11143	HY000	getaddrinfo() system call returned failure
11144	HY000	address is unavailable
11145	HY000	semaphore set exists
11146	HY000	unable to create a semaphore set
11147	HY000	unable to return a semaphore set
11148	HY000	unable to set value a semnum-th semaphore
11149	HY000	unable to performs operations on selected semaphores
11150	HY000	unable to remove a semaphore set

## A.2 Datatype and Operation Related Error

- Error code: GOLDILOCKS-specific error code
- SQLSTATE: SQL standard state code
- Message: Error message

**Table A-2** Datatype and operation related error

Error code	SQLSTATE	Message
12000	HY000	failed to initialize datatype layer
12001	HYC00	not implemented feature, in a function %s
12002	22001	byte length of data greater than column length
12003	22001	character length of data greater than column length
12004	22001	data converted with truncation of fractional digits
12005	22001	conversion of data would result in loss of whole digits
12006	22018	data value is not a numeric literal
12007	22003	data is outside the range of the data type to which the number is being converted
12008	22001	data is greater than 0, less than 2, and not equal to 1
12009	22003	data is less than 0 or greater than or equal to 2
12010	22001	(byte length of data)/2 is greater than column byte length
12011	22003	data value is not a hexadecimal value
12012	22008	data value is a valid timestamp literal; time portion is nonzero
12013	22018	data value is not a valid date literal or timestamp literal
12014	22008	data value is a valid timestamp literal; fractional seconds portion is nonzero
12015	22018	data value is not a valid time literal or timestamp literal
12016	22008	data value is a valid timestamp literal; fractional seconds portion truncated
12017	22018	data value is not a valid date literal or time literal or timestamp literal
12018	22015	data value is a valid interval value; the value in one of the fields is truncated
12019	22018	data value is not a valid interval literal
12020	22001	number of digits greater than column byte length
12021	22001	number of characters greater than column byte length
12022	22003	data converted with truncation of whole digits
12023	22003	data is outside the range of the data type to which the number is being converted
12024	22001	data is greater than 0, less than 2, and not equal to 1
12025	22003	data is less than 0 or greater than or equal to 2
12026	22015	interval data truncated
12027	22001	byte length of data greater than column length
12028	22001	character length of data greater than column length
12029	22003	byte length of data not equal to SQL data length

Error code	SQLSTATE	Message
12030	22001	column byte length is less than %d
12031	22008	data value is not a valid date
12032	22007	data value is not a valid date format
12033	22001	column byte length is less than %d
12034	22018	data value is not a valid GUID
12035	22001	column byte length is less than %d
12036	22001	data value is not a valid time
12037	22007	data value is not a valid time format
12038	22001	column byte length is between %d and character byte length
12039	22001	column byte length is less than %d
12040	22008	data value is not a valid timestamp
12041	22008	time fields are nonzero
12042	22007	data value does not contain a valid date
12043	22008	fractional seconds fields are nonzero
12044	22007	data value does not contain a valid time
12045	22008	fractional seconds fields are truncated
12046	22007	data value does not contain a valid timestamp
12047	22001	column byte length is less than character byte length
12048	22015	data value is not a valid interval literal
12049	22003	conversion resulted in truncation of whole digits
12050	22015	one or more fields of data value were truncated during conversion
12051	22001	column byte length is less than character byte length
12052	22015	data value is not a valid interval literal
12053	22003	conversion resulted in truncation of whole digits
12054	22015	one or more fields of data value were truncated during conversion
12055	01004	byte length of data greater equal than buffer length
12056	01004	character length of data greater equal than buffer length
12057	01S07	data converted with truncation of fractional digits
12058	22003	conversion of data would result in loss of whole digits
12059	22018	data is not numeric literal
12060	22003	data is outside the range of the data type to which the number is being converted
12061	01S07	data is greater than 0, less than 2, and not equal to 1
12062	22003	data is less than 0 or greater than or equal to 2
12063	01S07	data value is a valid timestamp-value; time portion is nonzero
12064	22018	data value is not a valid date-value or timestamp-value
12065	01S07	data value is a valid timestamp-value; fractional seconds portion is nonzero
12066	22018	data value is not a valid time-value or timestamp-value
12067	22018	data value is not a valid date-value or time-value or timestamp-value
12068	01S07	data value is a valid interval value;truncation of one or more trailing fields

Error code	SQLSTATE	Message
12069	22015	data value is a valid interval; leading field significant precision is lost
12070	22018	data value is not a valid interval value
12071	01004	number of whole digits is less than buffer length
12072	22003	number of whole digits is greater than buffer length
12073	01S07	data converted with truncation of fractional digits
12074	22003	conversion of data would result in loss of whole digits
12075	22003	data is outside the range of the data type to which the number is being converted
12076	01S07	data is greater than 0, less than 2, and not equal to 1
12077	22003	data is less than 0 or greater than or equal to 2
12078	22003	byte length of data is greater than buffer length
12079	01S07	fractional seconds portion truncated
12080	22015	whole part of number truncated
12081	22003	buffer length is less equal than 1
12082	22003	buffer length is less than 1
12083	01004	(byte length of data)/2 is greater equal than buffer length
12084	01004	(character length of data)/2 is greater equal than buffer length
12085	01004	byte length of data is greater than buffer length
12086	01004	buffer length is between %d and character byte length
12087	22003	buffer length is less than %d
12088	22003	byte length of data is greater than buffer length
12089	22003	buffer length is less than %d
12090	22003	byte length of data is greater than buffer length
12091	01004	buffer length is between %d and character byte length
12092	22003	buffer length is less than %d
12093	22003	byte length of data is greater than buffer length
12094	01004	buffer length is between %d and character byte length
12095	22003	buffer length is less than %d
12096	01004	buffer length is between %d and character length
12097	22003	byte length of data is greater than buffer length
12098	01S07	time portion of timestamp is nonzero
12099	01S07	fractional seconds portion of timestamp is nonzero
12100	01S07	fractional seconds portion of timestamp is truncated
12101	01S07	trailing fields portion truncated
12102	22015	leading precision of target is not big enough to hold data from source
12103	22003	interval precision was a single field and truncated whole
12104	22015	interval precision was not a single field
12105	22003	byte length of data is greater than buffer length
12106	01004	number of whole digits is less than buffer length
12107	22003	number of whole digits is greater equal than buffer length

Error code	SQLSTATE	Message
12108	01S07	trailing fields portion truncated
12109	22015	leading precision of target is not big enough to hold data from source
12110	01S07	interval precision was a single field and truncated fractional
12111	22003	interval precision was a single field and truncated whole
12112	07006	interval precision was not a single field
12113	22003	byte length of data is greater than buffer length
12114	01004	number of whole digits is less than buffer length
12115	22003	number of whole digits is greater equal than buffer length
12116	22009	invalid time zone displacement value
12117	42000	invalid number of arguments
12118	42000	inconsistent datatype of function parameters: %s
12119	42000	comparison is not applicable: %s and %s
12120	42000	conversion is not applicable: from %s to %s
12121	22021	invalid character value in character set repertoire
12122	22012	divisor is equal to zero
12123	22018	data is not boolean literal
12124	HY000	invalid argument for factorial function
12125	22027	trim set should have only one character
12126	22008	datetime field overflow
12127	HY000	invalid ROWID
12128	22019	invalid escape character
12129	HY000	invalid character set identifier
12130	HY000	invalid extract field for extract source
12131	42000	inconsistent datatypes: argument[%d] expected %s
12132	HY000	date format value exceeds maximum length (%d)
12133	HY000	date format not recognized
12134	HY000	format code appears twice
12135	HY000	%s conflicts with %s
12136	HY000	literal does not match format string
12137	HY000	input value not long enough for date format
12138	HY000	date format picture ends before converting entire input string
12139	HY000	year must be between %s and %s, and not be 0
12140	2200C	missing or illegal character following the escape character
12141	HY000	not a valid month
12142	HY000	a non-numeric character was found where a numeric was expected
12143	HY000	day of month must be between 1 and last day of month
12144	HY000	not a valid day of the week
12145	HY000	day of year must be between 1 and 365 (366 for leap year)
12146	HY000	format code cannot appear in date input format
12147	HY000	BC/B.C. or AD/A.D. required

Error code	SQLSTATE	Message
12148	HY000	julian date must be between 0 and 5373484
12149	HY000	%s may only be specified once
12150	HY000	Julian date precludes use of day of year
12151	HY000	Not enough format info buffer
12152	HY000	hour must be between %d and %d
12153	HY000	minute must be between 0 and 59
12154	HY000	second must be between 0 and 59
12155	HY000	the fractional seconds must be between 0 and 999999
12156	HY000	time zone hour must be between -14 and 14
12157	HY000	time zone minute must be between 0 and 59
12158	HY000	seconds in day must be between 0 and 86399
12159	HY000	AM/A.M. or PM/P.M. required
12160	HY000	HH24 precludes use of meridian indicator
12161	HY000	%s conflicts with use of %s
12162	HY000	invalid XID string
12163	HY000	date not valid for month specified
12164	HY000	signed year precludes use of BC/AD
12165	HY000	number format value exceeds maximum length (%d)
12166	HY000	invalid number format model
12167	HY000	cannot use %s twice
12168	HY000	cannot use %s and %s together
12169	22001	string data, right truncation
12170	HY000	argument '%d' is out of range
12171	HY000	invalid datepart for data type %s
12172	42000	maximum number of arguments exceeded
12173	42000	invalid char length units(%s): use OCTETS or CHARACTERS
12174	22023	The argument of %s function is invalid
12175	22023	The argument [%d] of %s function is invalid
12176	HY000	internal error, in a function %s
12177	HY000	not supported data type ( %s )
12178	HY000	data type specifier is out of range ( type : %d, range : %d to %d )
12179	HY000	precision specifier is out of range( type : %s, precision : %d, range : %d to %d )
12180	HY000	leading precision specifier is out of range( type : %s, precision : %d, range : %d to %d )
12181	HY000	scale specifier is out of range( type : %s, scale : %d, range : %d to %d )
12182	HY000	fractional second precision specifier is out of range( type : %s, precision : %d, range : %d to %d )
12183	HY000	character length unit specifier is out of range( type : %s, character length unit : %d, range : %d to %d )

Error code	SQLSTATE	Message
12184	HY000	interval indicator specifier is out of range( type : %s, indicator : %d, range : %d to %d )
12185	42000	%s and %s cannot be matched
12186	0A000	not supported function %s
12187	39000	failed to open customer built-in function library (%s)

## A.3 Resource Management Related Error

- Error code: GOLDILOCKS-specific error code
- SQLSTATE: SQL standard state code
- Message: Error message

**Table A-3** Resource management related error

Error code	SQLSTATE	Message
13000	HY000	Failed to initialize kernel layer
13001	HY000	kernel layer is not initialized yet
13002	HY000	Invalid argument
13003	HY000	Invalid shared memory segment type
13004	HY000	static shared memory segment is corrupted
13005	HY000	maximum number of shared memory segment num exceeded
13006	HY000	kernel layer internal error - %s
13007	42000	identifier is too long
13008	HY000	comment is too long
13009	42S02	fixed table does not exist
13010	HY000	Insufficient static area
13011	HY000	Unable to extend memory: [MAX: %ld, TOTAL: %ld, ALLOC: %ld] DESC: %s
13012	HY000	too many files are opened
13013	HY000	Property(%s) does not exist
13014	HY000	Unable to change property at this startup phase.(%s)
13015	0U000	Unable to change read-only property.(%s)
13016	22000	Invalid property value.(%s)
13017	0U000	Specified property cannot be modified.(%s)
13018	22000	Specified property cannot be modified with this SCOPE option.(%s)
13019	22000	Specified property cannot be modified.(%s)
13020	22000	Invalid GOLDILOCKS_DATA Directory
13021	22000	Invalid SID
13022	HY004	Invalid property data type
13023	22000	Invalid Property ID
13024	HY000	exceeded maximum number of processes
13025	HY000	File does not exist (%s)
13026	HY000	File exist (%s)
13027	HY000	File Process Error
13028	HY000	Property is not ReadOnly
13029	HY000	ReadOnly Property Already Setted
13030	HY000	Property File Parsing Error Line (%d)
13031	0A000	Unsupported return type is used



Error code	SQLSTATE	Message
13032	0A000	Function does not exist
13033	HY000	It can not make range
13034	08S01	Service is not available
13035	HY000	Specified Breakpoint name is not registered yet
13036	HY000	General abort error of Breakpoint
13037	HY000	Invalid Session Name
13038	HYT00	Exceeded maximum idle time
13039	HYT00	Exceeded maximum query time
13040	08S01	Communication link failure
13041	RD000	User session ID does not exist
13042	08004	Server rejected the connection
13043	HY008	operation canceled
13044	RD000	invalid process identifier
13045	08004	mismatched binary version - server(%s.%d.%d.%d), client(%s.%d.%d.%d.%d)
13046	HY000	session cannot be killed now
13047	22003	data is outside the range of the data type to which the number is being converted
13048	22015	one or more fields of data value were truncated during conversion
13049	HYC00	not implemented feature, in a function
13050	HY000	insufficient plan cache memory
13051	HY000	Unable to attach the shared memory segment. File does not exist(%s)
13052	42000	invalid dump option string: %s
13053	42000	dump object modified by concurrent statement
13054	42000	invalid numa map (%s)
13055	HY000	AS ADMIN must be executed in dedicated session
13056	HY000	unable to create file '%s' - already in use
13057	HY000	Property(%s) is desupported
13058	HY000	memory alloc size is too large: [MAX: %ld, ALLOC: %ld] DESC: (%d)%s
13059	HYT00	Exceeded maximum packet allocation time

## A.4 Storage Management Related Error

- Error code: GOLDLOCKS-specific error code
- SQLSTATE: SQL standard state code
- Message: Error message

**Table A-4** Storage management related error

Error code	SQLSTATE	Message
14000	HY000	Failed to initialize storage manager layer
14001	HY000	storage manager layer is not initialized yet
14002	HY000	Tablespace(%d) exceed datafile limit
14003	HY000	Tablespace(%d) is full
14004	HY000	Tablespace(%d) is already dropped
14005	HY000	System Tablespace is exists
14006	42000	Table is mutating, trigger/function may not see it
14007	RD000	deadlock detected
14008	24000	fetch out of sequence
14009	2200H	sequence generator limit exceeded
14010	22023	MAXVALUE cannot be made to be less than the current value
14011	22023	MINVALUE cannot be made to exceed the current value
14012	22023	cannot be made to be less than the current value
14013	22023	cannot be made to exceed the current value
14014	HY000	Fail to extend datafile(%u) of tablespace(%u) in Transaction(%ld)
14015	HY000	there is no extendible datafile in tablespace '%s'
14016	23001	some rows of base table violate uniqueness of index
14017	42000	invalid operation on fixed table or dump table
14018	42000	the operation is disallowed before %s startup phase
14019	HY000	log stream number string is invalid
14020	HY000	log stream %d already exists
14021	HY000	log group number string is invalid
14022	HY000	log group state must be INACTIVE or UNUSED
14023	HY000	log group %d already exists
14024	HY000	log member %s already exists
14025	42000	invalid dump option string: %s
14026	HYT00	resource busy or timeout expired
14027	HY000	datafile(%d,%d) is already dropped
14028	HY000	file '%s' is already exist
14029	HY000	sequence is not yet defined
14030	RD000	maximum index depth(%d) exceeded
14031	HY000	maximum key length(%d) exceeds

Error code	SQLSTATE	Message
14032	42000	can't serialize access for this transaction
14033	42000	unable to checkpoint in cds mode
14034	42000	unable to recover database in cds mode
14035	42000	some rows of base table violate not null constraint
14036	42000	invalid ROWID
14037	42000	Database is READ ONLY
14038	42000	unable to recover database in READ ONLY mode
14039	HY000	exceed segment MAXSIZE(%ld)
14040	HY000	Target object of dump table is mutating
14041	42000	cannot access the OFFLINE tablespace '%s'
14042	42000	cannot find the row (%ld)
14043	42000	file is already used in database '%s'
14044	42000	datafile not empty
14045	42000	cannot drop datafile of OFFLINE tablespace '%s'
14046	42000	file does not exist - '%s'
14047	42000	file is READ ONLY - '%s'
14048	42000	file is invalid or old version - '%s'
14049	42000	tablespace is not online - '%s'
14050	42000	tablespace is not offline - '%s'
14051	42000	media recovery required - '%s'
14052	42000	segment is unusable ( physical id : %ld )
14053	RD000	insufficient resource for sort
14054	HY000	internal error ( %s, %d )
14055	HY000	segment is corrupted ( physical id : %ld )
14056	HY000	failed to apply redo log ( lsn : %ld, lpsn : %d, physical id : %ld )
14057	HY000	dropping log group makes total log group count less than minimum log group count(%d)
14058	42000	log member is not exist - '%s'
14059	42000	log member is already used - '%s'
14060	HY000	CURRENT logfile is empty - '%s'
14061	HY000	next logfile to switch should be INACTIVE or UNUSED - '%s'
14062	42000	INITRANS must be less equal than MAXTRANS
14063	42000	cannot be added log member to exceed maximum log member count(%d)
14064	42000	the operation is disallowed at %s phase
14065	RD000	the instant table row length is too large
14066	RD000	the sort instant table key row length is too large
14067	HY000	cannot media recover; archive log mode not enabled
14068	HY000	logfile does not exist - '%s'
14069	HY000	cannot support ARCHIVELOG in cds mode
		control file is not recent; do media recovery with USING BACKUP CONTROLFILE

Error code	SQLSTATE	Message
14070	HY000	option
14071	HY000	cannot BACKUP; tablespace(%s) is offline
14072	HY000	cannot BACKUP; tablespace(%s) is temporary
14073	HY000	cannot BACKUP; tablespace is dropped
14074	HY000	cannot BACKUP; tablespace(%s) is already in backup
14075	HY000	cannot execute; tablespace(%s) is proceeding backup
14076	HY000	cannot END BACKUP; tablespace(%s) is not in backup
14077	HY000	cannot END BACKUP; none of the tablespaces are in backup
14078	HY000	cannot BACKUP; tablespace(%s) is proceeding other operation '%s'
14079	HY000	cannot BACKUP; database is already in backup
14080	HY000	cannot END BACKUP; database is not in backup
14081	HY000	cannot BACKUP; database is going shutdown
14082	HY000	(%s) is not an appropriate logfile to recover
14083	HY000	must use RESETLOGS option for database open
14084	HY000	must use NORESETLOGS option for database open
14085	HY000	(%s) was not a sufficiently old backup
14086	HY000	media recovery canceled
14087	HY000	cannot SHUTDOWN; backup in progress
14088	HY000	control file is corrupted
14089	HY000	LEVEL 0 INCREMENTAL BACKUP does not exist
14090	HY000	cannot flush logs; disabled log flushing
14091	HY000	(%s) is not valid logfile
14092	HY000	not exist incremental backup
14093	HY000	not exist valid incremental backup for tablespace(%s)
14094	HY000	datafile recovery required - datafile(%s) of tablespace(%s) corrupted
14095	HY000	backup file(%s) is corrupted
14096	23001	fail to build index ( %ld )
14097	HY000	control file is corrupted - '%s'
14098	HY000	maximum record length(%d) exceeds
14099	HY000	log member state must be UNUSED or INACTIVE
14100	HY000	dropping log member makes log member count of group(%d) less than minimum log member count(%d)
14101	HY000	log group id does not exist - '%d'
14102	HY000	cannot execute; recovery is in progress
14103	01000	Warning: media recovery needs a logfile including log (Lsn %ld)
14104	01000	Warning: suggestion '%s'
14105	HY000	control file '%s' is inconsistent with primary
14106	HY000	tablespace (%s) is taken offline as the result of a write error
14107	HY000	given LOG_BLOCK_SIZE(%d) is not a suitable value for a size of log block; LOG_BLOCK_SIZE should be one of 512, 1024, 2048 or 4096.

Error code	SQLSTATE	Message
14108	HY000	cannot disable archivelog - exist tablespace needed media recovery.
14109	HY000	OFFLINE NORMAL disallowed; cannot be taken offline consistently.
14110	HY000	OFFLINE IMMEDIATE disallowed; noarchivelog mode
14111	HY000	cannot create COLUMNAR TABLE; given MIN ROW COUNT is too big to put into one page
14112	HY000	record size is too large for columnar table
14113	HY000	datafile '%s' is corrupted
14114	HY000	datafile '%s' is more recent than redo logfile
14115	HY000	transaction undo limit exceeded
14116	HY000	failed to journal log
14117	HY000	cannot end incomplete recovery; incomplete recovery never been begun
14118	HY000	property TRANSACTION_TABLE_SIZE value must be equal to or greater than '%d'
14119	HY000	property UNDO_RELATION_COUNT value must be equal to or greater than '%ld'
14120	HY000	sequence is dropped
14121	HY000	file '%s' does not match with database - file signature '%s', database signature '%s'
14122	HY000	there is a possibility that a deadlock occurs
14123	22023	INCREMENTBY sign cannot be changed in the cluster system
14124	HY000	RESTORE in progress
14125	HY000	exceed maximum journal file size
14126	HY000	there must be at least one recoverable member in the group
14127	HY000	object no longer exists
14128	HY000	invalid remote view scn
14129	HYT00	transaction allocation time exceeded
14130	HYT00	undo relation allocation time exceeded
14131	42000	unable to enable change tracking in cds mode
14132	42000	unable to enable change tracking in noarchivelog mode
14133	HY000	change tracking is already enabled
14134	HY000	change tracking is not enabled
14135	HY000	change tracking file is corrupted - '%s'
14136	HY000	failed to backup incremental because change tracking is being altered
14137	HY000	failed to disable change tracking because incremental backup is in progress
14138	HY000	exceed maximum insertable records ( %lu ) by transaction
14139	HY000	transaction(%ld) is timed out for waiting to resolve cluster deadlock
14140	HY000	the value of MAXTRANS to be changed must be equal to or greater than the current MAXTRANS '%d'
14141	HY000	shard '%d' exceeds maximum shard sequence
14142	HY000	cannot recover; database is going shutdown

Error code	SQLSTATE	Message
14143	HY000	cannot backup; database is proceeding other operation '%s'

## A.5 Dictionary Cash Related Error

- Error code: GOLDILOCKS-specific error code
- SQLSTATE: SQL standard state code
- Message: Error message

**Table A-5** Dictionary cash related error

Error code	SQLSTATE	Message
15000	HY000	failed to initialize execution library layer
15001	HY000	execution library layer is not initialized yet
15002	42000	%s: schema does not exist
15003	42000	%s: table or view does not exist
15004	42000	%s: index does not exist
15005	42000	%s: column does not exist
15006	23000	%s: dictionary integrity constraint violation by concurrent DDL execution
15007	HY090	not enough stack space to add entries
15008	HY000	table related objects are modified while validation
15009	HY000	Invalid argument
15010	42000	object modified by concurrent DDL execution
15011	HYC00	not implemented feature, in a function %s
15012	42000	user dropped by other session
15013	42000	user default schema dropped
15014	42000	user default data tablespace dropped
15015	42000	user default temporary tablespace dropped
15016	0Y002	limit(%d) on the number of named cursor exceeded
15017	42000	DDL not allowed for supplemental log table
15018	42000	cluster member '%s' has already joined in an other cluster system
15019	42000	the %s of cluster member '%s' is not compatible with the cluster system
15020	42000	tablespace '%s' of the cluster system does not exist at cluster member '%s'
15021	42000	tablespace '%s' of the cluster member '%s' does not exist at the cluster system
15022	42000	the %s of the tablespace '%s' at cluster member '%s' is not compatible with the cluster system
15023	HY000	limit(%d) on the number of named instant table exceeded
15024	42000	the cluster member '%s' does not join in a cluster system
15025	42000	startup phase of new cluster member should be OPEN
15026	HY000	internal error, in a function %s
15027	42000	attempt to create, alter or drop an index on temporary table already in use
15028	42000	user default index tablespace dropped
15029	2F000	limit(%d) on the number of package instance exceeded

## A.6 SQL Handling Related Error

- Error code: GOLDILOCKS-specific error code
- SQLSTATE: SQL standard state code
- Message: Error message

**Table A-6** SQL handling related error (16000~16099)

Error code	SQLSTATE	Message
16000	HY000	failed to initialize sql processor layer
16001	HYC00	not implemented feature, in a function %s
16002	HY000	invalid function sequence of sql processor layer
16003	42000	identifier is too long
16004	28000	invalid username/password; logon denied
16005	42000	name '%s.%s' is already used by an existing object
16006	42000	schema '%s' does not exist
16007	42000	schema '%s' is not writable
16008	42000	tablespace '%s' does not exist
16009	42000	tablespace '%s' is not writable
16010	42000	invalid value for PCTFREE or PCTUSED
16011	42000	invalid INITRANS option value
16012	42000	duplicate column name
16013	HY000	invalid value is prevented in validation step
16014	22023	INCREMENT must be a non-zero integer
16015	22023	START WITH cannot be less than MINVALUE
16016	22023	START WITH cannot be more than MAXVALUE
16017	22023	the number of values to CACHE must be greater than 1
16018	22023	number to CACHE must be less than one cycle
16019	22023	MINVALUE must be less than MAXVALUE
16020	22023	INCREMENT must be less than MAXVALUE minus MINVALUE
16021	22023	descending sequences that CYCLE must specify MINVALUE
16022	22023	ascending sequences that CYCLE must specify MAXVALUE
16023	22023	duplicate or conflicting CACHE/NO CACHE specifications
16024	42000	numeric precision specifier is out of range( %d to %d )
16025	42000	numeric scale specifier is out of range( %d to %d )
16026	42000	character length specifier is out of range( 1 to %d )
16027	42000	character varying length specifier is out of range( 1 to %d )
16028	42000	binary length specifier is out of range( 1 to %d )
16029	42000	binary varying length specifier is out of range( 1 to %d )
16030	42000	name already used by an existing constraint
		auto-generated name already used by an existing constraint, specify unique con...



Error code	SQLSTATE	Message
16031	42000	straint name
16032	42000	table can have only one primary key
16033	42000	such unique or primary key already exists in the table
16034	42000	name already used by an existing index
16035	42000	auto-generated name already used by an existing index, specify non-duplicate index name
16036	42000	'%s': invalid identifier
16037	42000	maximum number of key columns exceeded
16038	23000	integrity constraint violation
16039	3B000	savepoint '%s' never established in this session or is invalid
16040	42000	table or view does not exist
16041	42000	table '%s' is not writable
16042	42000	unique/primary keys in table referenced by foreign keys
16043	42000	table referenced by views
16044	42000	sequence does not exist
16045	42000	duplicate options
16046	42000	such column list already indexed
16047	22003	numeric value out of range
16048	42000	specified index does not exist
16049	42000	index '%s' is not writable
16050	42000	cannot modify index used for enforcement of unique/primary/foreign key
16051	HY000	not applicable
16052	42000	column not allowed here
16053	42000	not enough values
16054	42000	too many values
16055	22004	NULL value not allowed
16056	22004	cannot insert NULL into "%s"."%s"."%s"
16057	23000	unique constraint (%s.%s) violated
16058	42000	not applicable hint
16059	42000	not applicable datatype
16060	07002	bind variable does not exist
16061	22004	cannot update ("%s"."%s"."%s") to NULL
16062	42000	syntax error
16063	42000	fractional seconds precision specifier is out of range( %d to %d )
16064	42000	invalid interval indicator
16065	42000	interval leading precision specifier is out of range( %d to %d )
16066	42000	interval fractional seconds precision specifier is out of range( %d to %d )
16067	42000	invalid INITIAL storage option value
16068	42000	invalid NEXT storage option value
16069	42000	invalid MINSIZE storage option value

Error code	SQLSTATE	Message
16070	42000	invalid MAXSIZE storage option value
16071	42000	storage option MAXSIZE is less than MINSIZE
16072	42000	duplicate or conflicting NULL and/or NOT NULL specifications
16073	42000	duplicate UNIQUE/PRIMARY KEY specifications
16074	42000	sequence number not allowed here
16075	42000	inconsistent datatypes : expected %s
16076	42000	invalid DATAFILE clause for alter of %s %s TABLESPACE
16077	42000	invalid DATAFILE clause for alter of %s %s TABLESPACE
16078	42000	invalid TEMPFILE clause for alter of %s %s TABLESPACE
16079	42000	file path is too long ( < %d )
16080	RD000	file size is out of range( %ld to %ld )
16081	42000	failed to open database : system threads are already exist.
16082	42000	invalid MAXTRANS option value
16083	42000	INITRANS must be less equal than MAXTRANS
16084	42000	result OFFSET must be 0 or positive numeric value
16085	42000	result LIMIT/FETCH must be positive numeric value
16086	42000	related objects are modified by concurrent DDL execution
16087	42000	boolean expression expected on where clause
16088	HY000	session cannot be killed now
16089	28000	built-in authorization(user or role) '%s' is not modifiable
16090	42000	built-in tablespace '%s' is not modifiable
16091	42000	built-in schema '%s' is not modifiable
16092	42000	built-in table or view '%s' is not modifiable
16093	42000	built-in index '%s' is not modifiable
16094	42000	built-in constraint '%s' is not modifiable
16095	42000	built-in sequence '%s' is not modifiable
16096	28000	authorization(user or role) '%s' does not exist
16097	42000	constraint '%s' does not exist
16098	07006	bind type mismatch of parameter number (%d)
16099	42000	the number of elements in the INTO list is mismatch

**Table A-7** SQL handling related error (16100~16199)

Error code	SQLSTATE	Message
16100	HY000	single-row subquery returns more than one row
16101	42000	parallel factor is out of range( 0 to %d )
16102	42000	invalid MEMORY clause for alter of %s %s TABLESPACE
16103	3C000	cursor '%s' is already declared
16104	42000	invalid cursor query: '%s'
16105	42000	invalid cursor property

Error code	SQLSTATE	Message
16106	34000	cursor '%s' does not exist
16107	34000	cursor '%s' is already open
16108	34000	cursor '%s' is not open
16109	42000	invalid use: cursor '%s' is not a declared cursor
16110	42000	invalid use: cursor '%s' is not an ODBC/JDBC cursor
16111	42000	cursor '%s' is not scrollable
16112	42000	query expression is not updatable
16113	42000	invalid phase(%s): executable phase of '%s' is between %s and %s
16114	42000	database is already mounted
16115	42000	database is already local opened
16116	42000	transaction is READ ONLY
16117	42000	database not mounted
16118	42000	supplemental logging attribute primary key exists
16119	42000	cannot drop nonexistent primary key supplemental logging
16120	42000	column referenced by views
16121	42000	column has a check constraint defined
16122	42000	pseudo column not allowed here
16123	42000	cannot select ROWID from not writable table
16124	42000	table can have only one identity column
16125	42000	column being added already exists in table
16126	42000	table must be empty to add mandatory (%s) column ('%s')
16127	42000	cannot modify INITIAL storage option
16128	42000	name '%s' is already used by an existing tablespace
16129	42000	duplicate datafile name
16130	42000	file is already exist - '%s'
16131	42000	cannot rename the built-in tablespace
16132	42000	cannot rename the OFFLINE tablespace
16133	42000	cannot drop tablespace: %s
16134	42000	cannot drop constraint - nonexistent constraint
16135	42000	cannot drop constraint - nonexistent primary key
16136	42000	cannot drop constraint - nonexistent unique key
16137	42000	the CDS database cannot be closed with ABORT option
16138	42000	the DS database can be closed with NORMAL option - deprecated
16139	42000	multiple ORDER BY clauses not allowed
16140	42000	multiple OFFSET clauses not allowed
16141	42000	multiple LIMIT clauses not allowed
16142	42000	column ambiguously defined
16143	42000	column part of USING clause cannot have qualifier
16144	42000	invalid OFFSET option value
16145	42000	invalid LIMIT option value

Error code	SQLSTATE	Message
16146	42000	common column name '%s' appears more than once in %s table
16147	42000	file is already used in database
16148	42000	tablespace not empty, use INCLUDING CONTENTS option
16149	42000	datafile does not exist in tablespace
16150	42000	cannot drop datafile of OFFLINE tablespace
16151	42000	cannot drop first datafile of tablespace
16152	42000	memory is already used in database
16153	42000	memory does not exist in tablespace
16154	42000	cannot drop first memory of tablespace
16155	42000	tablespace '%s' is not writable for logging index
16156	42000	tablespace '%s' is not writable for nologging index
16157	42000	ORDER BY item must be the number of a SELECT-list expression
16158	42000	group function is not allowed here
16159	42000	invalid number of arguments
16160	42000	group function is nested too deeply
16161	42000	not a single-group group function
16162	42000	mismatched datafile pairs
16163	42000	cannot rename datafile of ONLINE tablespace
16164	42000	file does not exist
16165	42000	tablespace is not online
16166	42000	tablespace is not offline
16167	42000	cannot offline temporary tablespace
16168	42000	cannot offline dictionary tablespace
16169	42000	cannot offline undo tablespace
16170	42000	invalid WAIT interval
16171	42000	column is not updatable
16172	22003	data is outside the range of the data type to which the number is being converted
16173	22015	one or more fields of data value were truncated during conversion
16174	42000	system session cannot be killed
16175	42000	hint not allowed in positioned DELETE
16176	42000	hint not allowed in positioned UPDATE
16177	34000	cursor '%s' is not updatable
16178	34000	cursor cannot identify the underlying table
16179	HY109	cursor was not positioned on a certain row
16180	HY109	cursor was positioned on a row that had been deleted
16181	42000	the CDS database cannot be closed with OPERATIONAL option
16182	42000	invalid segment identifier
16183	42000	FETCH position must be numeric value
16184	42000	cannot drop all columns in a table

Error code	SQLSTATE	Message
16185	42000	column already has a NOT NULL constraint
16186	42000	column does not have a NOT NULL constraint
16187	42000	null values found
16188	HY000	result set does not exist
16189	42000	column is not an identity column
16190	42000	column cannot be cast to incompatible type
16191	42000	column cannot be cast to decrease precision or scale
16192	42000	column cannot be cast to decrease string length
16193	42000	column cannot be cast to incompatible char length unit
16194	42000	column cannot be cast to incompatible interval indicator
16195	42000	float precision specifier is out of range( %d to %d )
16196	42000	file is already used in log stream - '%s'
16197	42000	duplicate logfile name
16198	42000	size of log file is smaller than minimum size of log file(%ld bytes).
16199	42000	can not find specified log member.

**Table A-8** SQL handling related error (16200~16299)

Error code	SQLSTATE	Message
16200	42000	the number of source logfiles is different from the number of targets
16201	42000	can not find specified log file.
16202	42000	name '%s' is already used by an existing schema
16203	42000	schema not empty, use CASCADE option
16204	RD000	another checkpoint is in progress
16205	42000	boolean expression expected
16206	RD000	maximum number of arguments exceeded
16207	42000	%s and %s cannot be matched
16208	42000	insufficient privileges
16209	42000	user %s lacks CREATE SESSION privilege; logon denied
16210	42000	lacks privilege (%s ON DATABASE)
16211	42000	lacks privilege (%s ON TABLESPACE "%s")
16212	42000	lacks privilege (%s ON SCHEMA "%s")
16213	42000	user name '%s' conflicts with another user or role name
16214	42000	tablespace '%s' is not data tablespace
16215	42000	tablespace '%s' is not temporary tablespace
16216	28000	user '%s' does not exist
16217	42000	user has own schema: DROP SCHEMA first
16218	42000	CASCADE must be specified to drop user '%s'
16219	42000	you may not GRANT/REVOKE privileges to/from yourself
16220	42000	duplicate authorization name in grantee/revokee list

Error code	SQLSTATE	Message
16221	42000	user default schema dropped
16222	42000	user default data tablespace dropped
16223	42000	user default temporary tablespace dropped
16224	42000	no privileges to GRANT ALL PRIVILEGES
16225	42000	insufficient privilege to GRANT
16226	42000	duplicate privilege listed
16227	42000	cannot drop a user that is currently connected
16228	42000	fixed table not grantable/revokable
16229	42000	invalid old password
16230	42000	schema element does not match schema identifier
16231	28000	cannot GRANT/REVOKE privileges to/from built-in authorization
16232	28000	cannot REVOKE privileges you did not grant to '%s'
16233	HY000	OFFLINE IMMEDIATE disallowed; noarchivelog mode
16234	HY000	OFFLINE IMMEDIATE disallowed; no logging tablespace
16235	2B000	dependent privilege descriptors still exist
16236	0A000	not supported query%s
16237	42000	a subquery block has incorrect number of result columns
16238	42000	ORDER BY item must be the number of a SELECT-list expression
16239	42000	expression must have same datatype as corresponding expression
16240	42000	subquery expressions not allowed here
16241	42000	invalid number of column names specified
16242	42000	must name this expression with a column alias
16243	01000	Warning: View definition has compilation errors
16244	42000	bind variables not allowed for data definition operations
16245	42000	view "%s.%s" has errors
16246	42000	illegal use of %s data type
16247	HY000	cannot BACKUP; noarchivelog mode
16248	HY000	cannot RECOVER TABLESPACE; tablespace is in use
16249	HY000	cannot SHUTDOWN; backup in progress
16250	HY000	RECOVER UNTIL CANCEL can be issued by directly attached session only - deprecated
16251	42000	single-row subquery returns more than one row
16252	42000	circular view definition encountered
16253	42000	only base table columns are allowed to GRANT/REVOKE
16254	42000	lacks privilege (%s ON TABLE "%s"."%s")
16255	42000	lacks privilege (USAGE ON SEQUENCE "%s"."%s")
16256	07001	wrong number of parameters
16257	HY000	argument of CASE/WHEN must be type boolean
16258	HY000	the XID does not exist
16259	HY000	the XID string is not valid

Error code	SQLSTATE	Message
16260	HY000	the global transaction is in progress
16261	42000	invalid INCREMENTAL BACKUP LEVEL specified : %d
16262	42000	INCREMENTAL BACKUP LEVEL 0 cannot have any BACKUP options
16263	HY000	cannot RESTORE TABLESPACE; tablespace is in use
16264	HY000	transaction is in progress
16265	42000	outer join operator (+) cannot be used with ANSI joins
16266	42000	outer join operator (+) not allowed in %s
16267	42000	an outer join cannot be specified on a correlation column
16268	42000	a predicate may reference only one outer-joined table
16269	42000	a table may be outer joined to at most one other table
16270	42000	two tables cannot be outer-joined to each other
16271	42000	RESTART value cannot be made to be less than the MINVALUE
16272	42000	RESTART value cannot be made to exceed the MAXVALUE
16273	42000	MINVALUE cannot be made to exceed the current value
16274	42000	MAXVALUE cannot be made to be less than the current value
16275	42000	MINVALUE cannot be made to exceed the START WITH value
16276	42000	MAXVALUE cannot be made to be less than START WITH value
16277	42000	log group id is already used
16278	42000	identity column cannot have a default value
16279	42000	DEFAULT expression has errors
16280	42000	the statement is disallowed
16281	42000	resource manager doing work outside transaction
16282	42000	MEMORY tablespace does not support an AUTOEXTEND option
16283	HY000	invalid ROWID
16284	42000	unable to execute in CDS mode
16285	RP000	failed to create system threads
16286	HY000	valid incremental backup does not exist
16287	42000	log group id does not exist
16288	42000	invalid string value specified
16289	42000	into clause can have only one row
16290	42000	SHUTDOWN must be executed in dedicated session
16291	40002	transaction rollback: integrity constraint violation
16292	42000	column length specifier is out of range( 1 to %d ) for columnar table
16293	42000	columnar table does not support LONG VARCHAR and LONG VARBINARY
16294	42000	cannot defer a constraint that is not deferrable
16295	42000	invalid NOT NULL constraint specified on an identity column
16296	42000	constraint '%s' is not deferrable
16297	42000	duplicate constraint name specified
16298	42000	cannot make primary key supplemental log data with primary key constraint violation

Error code	SQLSTATE	Message
16299	42000	datafile does not exist in database

**Table A-9** SQL handling related error (16300 ~ 16399)

Error code	SQLSTATE	Message
16300	42000	too many SQL resource
16301	42000	name '%s' is already used by an existing public synonym
16302	42000	private synonym '%s' to be dropped does not exist
16303	42000	public synonym '%s' to be dropped does not exist
16304	42000	looping chain of synonyms
16305	42000	synonym translation is no longer valid
16306	42000	expression is out of iteration time scope
16307	42000	constant value expression expected
16308	42000	invalid or redundant resource
16309	42000	the account is locked
16310	42000	the password will expire in %ld days
16311	42000	the password will expire soon
16312	42000	the password has expired
16313	42000	the password cannot be reused
16314	42000	cannot lock "SYS" account
16315	42000	profile '%s' already exists
16316	42000	function '%s' not found
16317	42000	profile '%s' has users assigned, cannot drop without CASCADE
16318	42000	profile '%s' does not exist
16319	42000	cannot assign PROFILE to "SYS" account
16320	42000	cannot assign DEFAULT parameter value to "DEFAULT" profile
16321	42000	password length less than '%d'
16322	42000	password must contain at least '%d' letter(s)
16323	42000	password must contain at least uppercase '%d' character(s)
16324	42000	password must contain at least lowercase '%d' character(s)
16325	42000	password must contain at least '%d' digit(s)
16326	42000	password must contain at least '%d' special character(s)
16327	42000	password same as or similar to user name
16328	42000	password contains the user name reversed
16329	42000	password same as or similar to database name
16330	42000	password too simple
16331	42000	Password should differ from the old password by at least '%d' characters
16332	42000	constant value does not support LONG VARCHAR and LONG VARBINARY
16333	42000	value of parameter number (%d) must be consistent datatype
16334	42000	invalid value is prevented in parameter number (%d)



Error code	SQLSTATE	Message
16335	42000	UPDATE primary key not allowed for supplemental log table
16336	42000	cluster group '%s' does not exist
16337	42000	duplicate cluster object listed
16338	42000	cluster domain '%s' does not exist
16339	42000	invalid hash shard count (must between %d and %d)
16340	42000	not found available sharding key column
16341	42000	cannot specify sharding strategy and placement for a table on dictionary schema '%s'
16342	HYC00	not implemented feature for cluster system, in a function %s
16343	42000	invalid syntax for a stand-alone system
16344	42000	database is not local opened
16345	42000	database is already opened
16346	42000	name '%s' is already used by an existing cluster object
16347	42000	cluster port is out of range( %d to %d )
16348	42000	duplicate cluster connection listed
16349	42000	the first cluster group does not contain local cluster member '%s'
16350	42000	maximum number of cluster members exceeded
16351	HY000	failed to connect to the cluster member '%s'
16352	42000	mismatch local cluster member with location file
16353	42000	conflict between new cluster member and location file
16354	HY000	connection of member '%s' is broken
16355	42000	non-deterministic function not allowed here
16356	42000	version conflict
16357	42000	must be accessible to at least one member of group '%s'
16358	42000	accessible member does not exist
16359	42000	no inactive members
16360	42000	cloned table "%s"."%s" must be accessible to at least one member
16361	42000	sharded table "%s"."%s" must be accessible to at least one member of group '%s'
16362	42000	NODE SHARDED table cannot be rebalanced
16363	42000	the cluster member '%s' does not join in a cluster system
16364	42000	cluster group has sharded data
16365	42000	schema name of instant table must be SESSION_SCHEMA
16366	42000	hash shard count smaller than AT CLUSTER GROUP list
16367	42000	cannot drop sharding key column
16368	42000	not a fixed table
16369	42000	not a statistics table
16370	42000	have to create one or more datafiles to each member
16371	42000	conversion is not applicable
16372	42000	duplicate shard name

Error code	SQLSTATE	Message
16373	42000	the number of elements in shard bound mismatch the sharding key columns
16374	42000	range shard bound value must be one of: valid constant or MAXVALUE
16375	42000	only MAXVALUE allowed after MAXVALUE
16376	42000	multiple MAX shard defined
16377	42000	MAX shard not defined
16378	42000	duplicate shard bound value
16379	42000	failed to rebalance some tables
16380	HYC00	UNIQUE or PRIMARY KEY must include all sharding key columns for cluster system
16381	42000	invalid shard count (must between %d and %d)
16382	42000	cluster member '%s' does not exist
16383	42000	domain '%s' is unknown
16384	42000	multiple DEFAULT shard defined
16385	42000	DEFAULT shard not defined
16386	42000	DEFAULT cannot be specified with other values
16387	42000	list shard bound value must be one of: valid constant or NULL or DEFAULT
16388	HYC00	does not support deferrable constraints in the cluster system
16389	42000	domain names of the datafile for renaming don't mismatch
16390	42000	invalid table for sharding strategy and placement specified
16391	42000	the number of sharding key in function is mismatch
16392	HYC00	does not support ROWID in the cluster system
16393	01000	Warning: accessible member does not exist
16394	01000	Warning: connection of member '%s' is broken
16395	01000	Warning: must be accessible to at least one member of group '%s'
16396	42000	exceeds the maximum number of nodes
16397	42000	exceeds the maximum number of groups
16398	42000	the domain of property does not match with domain '%s'
16399	42000	cannot insert or update a generated always identity column, value shall be a DEFAULT

**Table A-10** SQL handling related error (16400 ~ 16499)

Error code	SQLSTATE	Message
16400	HY000	cannot RECOVER UNTIL CHANGE SCN; invalid SCN format
16401	42000	invalid SAMPLE size specified
16402	42000	duplicate index name
16403	42000	failed to join some of nodes to the global database
16404	42000	cannot execute the statement with OS user permissions
16405	42000	some tables in the database need to be rebalanced
16406	42000	invalid routine name
16407	42000	procedure or function does not exist

Error code	SQLSTATE	Message
16408	42000	bind variables not allowed for procedures or functions
16409	01000	Warning: Routine definition has compilation errors
16410	42000	Startup driver node must have the latest data - a suitable startup driver node is '%s' member
16411	42000	maximum number of recursive SQL levels (%d) exceeded.
16412	42000	all of shards in a table must be online.
16413	42000	LOCAL_OFFLINE domain must be specified to base table
16414	42000	domain option not allowed here
16415	42000	LOCAL_OFFLINE domain cannot be used with other domains
16416	42000	lacks privilege (EXECUTE ON PROCEDURE "%s"."%s")
16417	42000	active member '%s' cannot be offlined
16418	42000	cluster member '%s' does not exist in cluster group '%s'
16419	42000	object identifier not allowed here
16420	0A000	does not support adding identity column in the cluster system
16421	0A000	does not support deferred unique integrity in the cluster system
16422	0A000	does not support SERIALIZABLE in the cluster system
16423	42000	does not support non-deterministic DML in the cluster system : global secondary index expected
16424	42000	function generating different values is not allowed here
16425	42000	procedure, function, package, or type is not allowed here
16426	42000	does not support ADD COLUMN DEFAULT generating different values in the cluster system
16427	42000	invalid events (%s)
16428	42000	cluster system is modified by concurrent cluster DDL execution
16429	42000	does not support cursor in the cluster system : global secondary index expected
16430	42000	the cluster database can be closed only with ABORT or NORMAL option
16431	42000	non-deterministic expression not allowed here : may lead to a replica synchronization failure
16432	42000	global secondary index already exists in table
16433	42000	global secondary index does not exist in table
16434	HY000	invalid grid is prevented in cluster operation, in a function %s
16435	HY000	duplicate source datafile name
16436	HY000	duplicate target datafile name
16437	HY000	cannot execute on cloned tables
16438	HY000	invalid shard name - '%s'
16439	HY000	cannot move shard to the same group
16440	HY000	cannot execute on cluster wide sharded tables
16441	42000	not analyzed table
16442	42000	invalid analyzed file format (%s)
16443	42000	old plan

Error code	SQLSTATE	Message
16444	42000	invalid cluster group name
16445	42000	REBALANCE EXCLUDE can be executed only on cluster wide sharded tables
16446	42000	REBALANCE EXCLUDE target group is empty
16447	HY000	internal error ( %s, %d )
16448	42000	of the total '%d' tables, '%d' tables failed to move shard
16449	42000	cluster group does not have sharded data
16450	42000	exceeded global property lock timeout
16451	42000	rownum not allowed here
16452	42000	rownum not allowed in sensitive cursor
16453	42000	rownum not allowed in positioned UPDATE
16454	42000	function '%s' not allowed here
16455	42000	routine "%s.%s" has errors
16456	42000	the startup phase '%s' of cluster member '%s' is mismatch with the required startup phase '%s'
16457	42000	the connection map of cluster member '%s' is mismatch with local connection map
16458	42000	reserved domain cannot be used with other domains
16459	42000	cannot execute on hash sharded tables
16460	42000	cannot execute on range sharded tables
16461	42000	invalid shard values
16462	42000	cannot split shard - source shard cannot be empty
16463	42000	first CREATE CLUSTER GROUP must include only one cluster member
16464	HY000	unsupported feature with temporary table
16465	42000	cannot drop local cluster group
16466	42000	cannot execute with SERIALIZABLE
16467	42000	table '%s' is READ ONLY
16468	HY000	cannot create TEMPORARY object in a NON-TEMPORARY tablespace
16469	0A000	cannot execute on global connection
16470	42000	datafile size specified is smaller than minimum required '%ld'
16471	42000	audit policy '%s' does not exists
16472	42000	audit policy cannot be dropped as it is currently enabled
16473	42000	audit policy '%s' already exists
16474	42000	not auditable option
16475	42000	audit policy already applied with the BY clause
16476	42000	audit policy already applied with the EXCEPT clause
16477	42000	not auditable object
16478	42000	tablespace '%s' is not temporary tablespace or data tablespace
16479	42000	failed to update system version - %s
16480	42000	cannot set irrecoverable on the local cluster member
16481	42000	global tempory table segment no longer exists

Error code	SQLSTATE	Message
16482	42000	database is not accessible; '%s' has detached from the cluster
16483	42000	of the total '%d' sequences, '%d' sequences failed to synchronize
16484	42000	of the total '%d' identity columns, '%d' identity columns failed to synchronize
16485	42000	table does not have an identity column
16486	RD000	maximum file size is out of range( %ld to %ld )
16487	42000	only range sharded table is allowed
16488	42000	shards being merged are not adjacent
16489	42000	cluster group name must be specified
16490	42000	mismatch the group name of the source shard '%s'
16491	42000	exceed the maximum number of shards (%d)
16492	42000	can not perform DDL/DML over objects in Recycle Bin
16493	42000	object not in Recycle Bin
16494	42000	original name is used by an existing object
16495	HY000	package or package body does not exist
16496	42000	built-in package '%s' is not modifiable
16497	42000	lacks privilege (EXECUTE ON PACKAGE "%s"."%s")
16498	42000	Only Btree indexes can be rebuilt
16499	42000	operation is not allowed on immutable table '%s'

**Table A-11** SQL handling related error (16500 ~ 16599)

Error code	SQLSTATE	Message
16500	0A000	cannot execute on global session
16501	42000	size of log file is larger than maximum size of log file(%ld bytes).
16502	42000	recursive WITH clause must reference itself directly in one of the UNION ALL branches
16503	42000	recursive WITH clause must reference itself in the last UNION ALL branch
16504	42000	recursive WITH clause must use UNION ALL operation
16505	42000	recursive WITH clause must have column alias list
16506	42000	unsupported join in recursive WITH query
16507	42000	cycle mark value and non-cycle mark value must be one byte character
16508	42000	only recursive WITH element can have recursive search clause
16509	42000	unsupported operation in recursive branch of recursive WITH clause
16510	42000	unsupported use of WITH clause
16511	42000	cycle detected while executing recursive WITH query
16512	42000	CONNECT BY clause required in this query block
16513	42000	hierarchy function not allowed here
16514	42000	cycle detected while executing CONNECT BY Clause
16515	42000	ORDER SIBLINGS BY requires specific target expressions
16516	42000	invalid argument expressions for SYS_CONNECT_BY_PATH

Error code	SQLSTATE	Message
16517	42000	NOCYCLE keyword is required with CONNECT_BY_ISCYCLE
16518	42000	LOCAL_OFFLINE domain expected
16519	42000	global secondary index expected in cluster DML
16520	42000	long varying memory manager does not exist
16521	42000	invalid hash bucket count (must between 1 and %ld)
16522	42000	invalid cluster member position
16523	08S01	the database system is shutting down
16524	42000	package specification '%s' does not exist. package body requires its package specification
16525	42000	duplicate name found in WITH name list for WITH clause
16526	42000	only recursive WITH element can have recursive search clause
16527	42000	only recursive WITH element can have recursive cycle clause
16528	42000	illegal reference of a query name in WITH clause
16529	42000	recursive query name referenced more than once in recursive branch of recursive WITH clause element
16530	42000	number of WITH clause column names does not match number of elements in select list
16531	42000	sequence column name for SEARCH clause must not be part of the column alias list
16532	42000	cycle mark column name for CYCLE clause must not be part of the column alias list
16533	42000	sequence column for SEARCH clause must be different from the cycle mark column for CYCLE clause
16534	42000	element in sort specification list of SEARCH clause did not appear in the column alias list of the WITH clause element
16535	42000	element in cycle column list of CYCLE clause must appear in the column alias list of the WITH clause element
16536	42000	duplicate name found in search column list for SEARCH clause of WITH clause
16537	42000	duplicate name found in cycle column list for CYCLE clause of WITH clause
16538	42000	cycle mark value and non-cycle mark value must be one byte character string values
16539	42000	cycle value for CYCLE clause must be different from the non-cycle value
16540	42000	multiple WITH clauses not allowed
16541	42000	cannot affect row a second time
16542	42000	upsert not allowed for the row that caused more than one unique constraint violation
16543	42000	upsert is not allowed for the table with a deferrable constraint (%s.%s)
16544	01000	Warning: Package '%s.%s' has compilation errors
16545	42000	cloned table "%s"."%s" must have at least one online replica
16546	42000	sharded table "%s"."%s" must have at least one online replica of group '%s'
16547	01000	of the total '%d' tables in the database, '%d' tables have offline replica

Error code	SQLSTATE	Message
16548	01000	of the total '%d' tables in the member to be dropped, %d' tables have offline r eplica
16549	42000	invalid bind parameter
16550	HY000	failed to offline the already dropped cluster member
16551	HY000	shutdown cannot be performed on ipc
16583	42000	cannot transactional service: %s

## A.7 PSM Related Error

- Error code: GOLDILOCKS-specific error code
- SQLSTATE: SQL standard state code
- Message: Error message

**Table A-12** PSM related error

Error code	SQLSTATE	Message
17000	2F000	failed to initialize PSM processor layer
17001	2F000	not implemented feature (%s)
17002	2F000	duplicated label name
17003	2F000	duplicated exception name
17004	2F000	duplicated variable name
17005	2F000	not applicable expression type
17006	2F000	unknown variable or column name (%s)
17007	2F000	invalid expression
17008	2F000	wrong number of parameters
17009	2F000	NOT NULL constraint violation
17010	2F000	can not find label name
17011	2F000	duplicated field name
17012	2F000	unknown type name
17013	2F000	the type of record field should be scalar
17014	2F000	target host parameter of assignment is not bound in OUT mode
17015	2F000	cannot set constraint or initial value on non-scalar-type variable
17016	2F000	variables which have NOT NULL constraint should have initial values
17017	2F000	unhandled user exception
17018	2F000	pre-defined exception name not allowed in declare section
17019	2F000	OTHERS exception must be last among the exceptions of a block
17020	2F000	unknown exception
17021	2F000	Invalid error number for PRAGMA EXCEPTION_INIT
17022	2F000	A CASE statement must either list all possible cases or have an else clause
17023	2F000	duplicated error-code in same exception handler
17024	2F000	(%s) cannot be used as assignment target
17025	2F000	The command cannot be executed when global transaction is in the ACTIVE state
17026	2F000	Transaction is READ ONLY
17027	2F000	duplicated identifier
17028	2F000	out of scope
17029	2F000	too many depths of scope (limit=%d)
17030	2F000	invalid reference field (%s)



Error code	SQLSTATE	Message
17031	2F000	mismatch identifier type
17032	2F000	PSM compilation error
17033	2F000	duplicated cursor name
17034	2F000	return type of cursor is invalid
17035	2F000	invalid expression type
17036	2F000	cursor is not defined
17037	2F000	cursor is already open
17038	2F000	cursor is not open
17039	2F000	unknown cursor
17040	2F000	fetch target count mismatch
17041	2F000	execution fail
17042	2F000	bind variables not allowed for data definition operations
17043	2F000	no target-list for into clause
17044	2F000	returning-into need to bind variable with returning-into or using OUT clause
17045	2F000	no data found
17046	2F000	variables of record type can not be mixed with other variable
17047	2F000	only record-type variable allowed
17048	2F000	can not be used with INTO-clause and USING clause having OUT-modes
17049	2F000	can not use a expression in USING OUT binding
17050	2F000	query need to bind with INTO-clause for targets
17051	2F000	invalid statement-type
17052	2F000	Alias required in list of cursor to avoid duplicated target names
17053	2F000	schema or table object does not exist
17054	2F000	only record-type variable allowed
17055	2F000	this cursor must be declared with FOR-UPDATE to use with CURRENT OF
17056	2F000	invalid syntax error
17057	2F000	only select-into statement allowed
17058	2F000	source-name of return-type is not record-type or record-type variable
17059	2F000	source-name of rowtype must be a table, view, cursor, cursor-variable
17060	2F000	a cursor-variable with having return-type cannot be used in OPEN FOR dynamic-sql
17061	2F000	it can be allowed with only IN-Binding type
17062	2F000	duplicated routine name
17063	2F000	unknown routine name
17064	2F000	invalid routine name
17065	2F000	invalid routine object status
17066	2F000	a RAISE statement with no exception name must be inside an exception handler
17067	2F000	return types of Result Set variables or query do not match
17068	2F000	wrong number or types of arguments
17069	2F000	invalid variable usage

Error code	SQLSTATE	Message
17070	2F000	return statement in procedures or anonymous blocks cannot have <value> clause
17071	2F000	return statement in functions should have <value> clause
17072	2F000	existing state of routine has been discarded
17073	2F003	DDLs or DCLs cannot be invoked during DMLs or SELECT statements are executing in <code>W"%sW".W"%sW"</code>
17074	2F003	cannot begin transaction inside a query in <code>W"%sW".W"%sW"</code>
17075	2F003	cannot commit or rollback transaction inside a query or DML in <code>W"%sW".W"%sW"</code>
17076	2F000	application error <code>W"%sW"</code>
17077	2F000	the argument of collection type variable is not a constant expression
17078	2F000	a function with OUT-Parameter not allowed in expression
17079	2F000	a nested function not allowed in executing SQL
17080	2F002	cannot execute DML jobs inside a query
17081	2F000	program body of the routine is not defined
17082	2F000	bind parameter in target or return clause is not allowed
17083	2F000	Function "%s" returned without value
17084	2F000	The argument "%s" of routine "%s" is invalid
17085	2F000	a cursor (%s) already defined in package spec
17086	2F000	a cursor or routine (%s) declared in spec must be defined in package body
17087	2F000	existing state of package has been discarded
17088	2F000	invalid package object status
17089	2F000	cannot drop packages in use
17090	2F000	Cursor Variables cannot be declared as part of a package
17091	2F000	cannot perform nested updatable statements on cluster database
17092	2F000	invalid package name
17093	2F000	unsupported element data type
17094	2F000	IN cursor cannot be OPENed
17095	2F000	mismatch parameter count of routine(%s)
17096	2F000	mismatch parameter type of routine(%s)
17097	2F000	mismatch return type of function(%s)
17098	2F000	mismatch record field count of routine(%s)
17099	2F000	cycle detected when initialize package instance(%s)
17100	2F000	PSM(%s) compilation error
17101	2F000	PACKAGE(%s) Specification has compilation errors
17102	2F000	PACKAGE(%s) Body has compilation errors
17103	2F000	cannot use function in the same package

## A.8 Session Related Error

- Error code: GOLDILOCKS-specific error code
- SQLSTATE: SQL standard state code
- Message: Error message

**Table A-13** Session related error

Error code	SQLSTATE	Message
18000	HY000	Invalid Statement
18001	HY024	Invalid attribute value
18002	HY092	Invalid attribute/option identifier
18003	42000	Transaction is READ ONLY
18004	42000	Statement cannot execute as atomic action
18005	42000	Preparable phase is open phase
18006	08S01	Communication link failure
18007	HYC00	not implemented feature, in a function %s
18008	HY014	Limit on the number of SQL statement exceeded
18009	42000	The command cannot be executed when global transaction is in the ACTIVE state
18010	07009	Invalid descriptor index
18011	HY000	Character set not equal(%s and %s)
18012	HY010	fetch out of sequence
18013	HYC00	Optional feature not implemented
18014	07001	Wrong number of parameters
18015	24000	Invalid cursor state
18016	42000	remote xa transaction (%d.%ld) already exists
18017	42000	remote xa transaction (%d.%ld) does not exist

## A.9 ODBC Related Error

- Error code: GOLDILOCKS-specific error code
- SQLSTATE: SQL standard state code
- Message: Error message

**Table A-14** ODBC related error

Error code	SQLSTATE	Message
19000	HY009	Invalid use of null pointer
19001	HY092	Invalid attribute/option identifier
19002	08003	Connection not open
19003	IM001	Driver does not support this function
19004	IM004	Driver's SQLAllocHandle on SQL_HANDLE_ENV failed
19005	IM005	Driver's SQLAllocHandle on SQL_HANDLE_DBC failed
19006	08002	Connection name in use
19007	HY090	Invalid string or buffer length
19008	28000	Invalid authorization specification
19009	HY010	Function sequence error
19010	24000	Invalid cursor state
19011	HY012	Invalid transaction operation code
19012	HYC00	Optional feature not implemented
19013	HY003	Invalid application buffer type
19014	07009	Invalid descriptor index
19015	HY004	Invalid SQL data type
19016	HY105	Invalid parameter type
19017	HY009	Invalid argument value
19018	HY011	Attribute cannot be set now
19019	HY024	Invalid attribute value
19020	25000	Invalid transaction state
19021	HY000	General error
19022	07005	Prepared statement not a cursor-specification
19023	22001	String data, right truncated
19024	HY007	Associated statement is not prepared
19025	HY092	Option type out of range
19026	22002	Indicator variable required but not supplied
19027	01S01	Error in row
19028	HY016	Cannot modify an implementation row descriptor
19029	HY091	Invalid descriptor field identifier
19030	07006	Restricted parameter value violation
19031	22015	Interval field overflow

Error code	SQLSTATE	Message
19032	22003	Numeric value out of range
19033	01004	String data, right truncated
19034	22018	Invalid character value for cast specification
19035	01S07	Fractional truncation
19036	22008	Datetime field overflow
19037	22007	Invalid datetime format
19038	08S01	Communication link failure
19039	HY000	An invalid SQL type has occurred
19040	34000	Invalid cursor name
19041	HY000	Failed to atomic execution
19042	HY110	Invalid driver completion
19043	IM012	DRIVER keyword syntax error
19044	08001	Client unable to establish connection
19045	HY096	Information type out of range
19046	IM002	Data source not found and no default driver specified
19047	HY106	Fetch type out of range
19048	HY100	Uniqueness option type out of range
19049	HY101	Accuracy option type out of range
19050	HY097	Column type out of range
19051	HY098	Scope type out of range
19052	HY099	Nullable type out of range
19053	HY021	Inconsistent descriptor information
19054	01S02	Option value changed
19055	HY109	Invalid cursor position
19056	HY107	Row value out of range
19057	HYT00	Timeout expired
19058	2C000	Invalid or unknown NLS parameter value specified
19059	HY020	Attempt to concatenate a null value
19060	HY019	Non-character and non-binary data sent in pieces
19061	HY000	Invalid 'odbc.ini' specification, property : [%s]
19062	IM008	Dialog failed
19063	40001	Transaction rollback
19064	40003	Statement completion unknown
19065	08S01	Communication link failure
19066	01000	General warning
19067	HY104	Invalid precision or scale value
19068	40003	Retry the transactional operations
19069	08S01	Failed to communicate with locator
19070	08006	Unable to get cluster system information
19071	HY000	startup cannot be performed on ipc

## A.10 JDBC Related Error

- Error code: GOLDILOCKS-specific error code
- SQLSTATE: SQL standard state code
- Message: Error message

**Table A-15** JDBC related error

Error code	SQLSTATE	Message
21000	HV000	Not used error
21001	46001	Invalid connection url[%s]: [%s]
21002	46110	Unsupported feature: [%s]
21003	08S01	Invalid protocol: [%s]
21004	HV000	Invalid method call for read-only ResultSet
21005	08003	The Connection is already closed
21006	08003	The Statement is already closed
21007	08003	The ResultSet is already closed
21008	HV000	Invalid method call for forward-only ResultSet
21009	HV000	Invalid Wrapper type: [%s]
21010	HV000	Invalid argument: [%s]
21011	08000	Cannot connect to the server: %s
21012	08S01	Communication link failure: %s
21013	HV000	A mandatory property is omitted: [%s]
21014	HV000	Not a select query for executeQuery method
21015	HV000	The statement has produced a ResultSet
21016	HV000	This method cannot be called for a PreparedStatement
21017	HV000	Parameter type[%s] is mismatch with previous type[%s] during batch
21018	HV000	Lack of parameter: [%s]'th parameter
21019	HV000	No batch job added
21020	HV000	Batch job added
21021	22003	The value[%s] is out of range of [%s] type
21022	22026	The value length is mismatch[%s != %s]
21023	HV000	The value(%s type) cannot be converted to [%s] type
21024	08000	The connection timeout expired: [%s millis]
21025	HV000	The column is not found: [%s]
21026	3B000	Savepoint error: %s
21027	HV000	Cannot execute the query in auto-commit mode
21028	24000	Invalid cursor position
21029	HV000	No column has been read
21030	HV000	Encoding error: [%s]
21031	HV000	Decoding error: [%s]

Error code	SQLSTATE	Message
21032	HV000	Stream error: [%s]
21033	HV000	Trying to read the deleted row
21034	HV000	Invalid interval format string: [%s]
21035	HV000	The Statement has an opened ResultSet
21036	HV000	The RowId object is unknown
21037	08000	The failover failed
21038	07009	The parameterIndex is not valid: [%s]
21039	HY000	No data read
21040	HY000	Invalid locator protocol version
21041	HY000	not matched locator protocol command sequence number
21042	HY000	Unable to open the file '%s'
21043	HY000	Unable to read the file '%s'
21044	HY000	Unable to close the file '%s'
21045	HY000	invalid INI file format
21046	HY000	Parameter[%s]'s input data type is mismatched with output data type
21047	40001	Retry the transactional operations again
21048	08006	Unable to get cluster system information
21049	HY000	The Statement does not have a ResultSet
21050	08006	Unable to get location information
21051	HY000	Not exist node information - %s
21052	HY000	Operation on freed LOB

## A.11 Embedded SQL Related Error

- Error code: GOLDILOCKS-specific error code
- SQLSTATE: SQL standard state code
- Message: Error message

**Table A-16** Embedded SQL run-time library related error

Error code	SQLSTATE	Message
23000	42000	syntax error
23001	0A000	feature not supported
23002	HY000	Bind variable "%s" was not declared
23003	HY000	Application can't be initialized
23004	HY000	Application can't be finalized
23005	RD000	Service is not available
23006	RD000	Statement did not prepared
23007	08001	Client can't establish SQL-connection
23008	HY000	cursor "%s" is not open
23009	HY000	Application can't create semaphore
23010	HY000	Application can't destroy semaphore
23011	HY000	Application can't create allocator
23012	HY000	Application can't destroy allocator
23013	HY000	Application can't create symbol table
23014	HY000	Application can't destroy symbol table
23015	IM004	Driver's SQLAllocHandle on SQL_HANDLE_ENV failed
23016	IM001	Driver does not support ODBC 3.0
23017	HY000	Application can't allocate memory
23018	42000	Statement "%s" was not prepared
23019	42000	Descriptor name is too long
23020	HYC00	Not implemented feature, in a function %s
23021	07004	USING clause required for dynamic parameters
23022	07001	USING clause: illegal variable name/number
23023	07001	USING clause: not all variables bound
23024	07007	INTO clause required for result fields
23025	07001	INTO clause: illegal variable name/number
23026	07001	INTO clause: not all variables bound
23027	22002	null value, no indicator parameter
23028	07005	cursor "%s" statement is not a query
23029	08003	connection not open
23030	34000	cursor "%s" is not updatable
23031	08002	connection name "%s" in use



Error code	SQLSTATE	Message
23032	08002	duplicate connection context
23033	HY000	GROUPID type is only available with global connection
23034	42000	SELECT INTO returns too many rows
23035	24000	cursor "%s" is not declared
23036	24000	cursor "%s" is not closed
23037	24000	cursor "%s" is already opened
23038	24000	cursor "%s" is not a dynamic cursor

**Table A-17** Embedded SQL precompile related error

Error code	SQLSTATE	Message
41000	42000	syntax error
41001	0A000	feature not supported
41002	42000	Host variable "%s" not declared
41003	42000	Cursor "%s" not declared
41004	42000	"%s": file not exist
41005	42000	expression type does not match usage
41006	42000	Fatal error while doing embedded SQL preprocessing
41007	HY000	Precompiler can't create symbol table
41008	HY000	Precompiler can't destroy symbol table
41009	42000	identifier is too long
41010	42000	token "%s" is not valid in preprocessor expressions
41011	42000	multi-character character constant
41012	42000	floating constant in preprocessor expression
41013	42000	invalid suffix "%s" on integer constant
41014	42000	cursor name "%s" already declared
41015	07004	cursor "%s" is not a dynamic cursor
41016	42000	"%s" has no member named "%s"
41017	42000	storage size of "%s" isn't known
41018	42000	variable "%s" must be integer type
41019	42000	variable "%s" must be string type
41020	42000	invalid indicator variable type: indicator variable "%s" must have numeric type(c har/short/int/long)
41021	42000	duplicate "%s"
41022	42000	both "%s" and "%s" in declaration specifiers
41023	42000	two or more data types in declaration specifiers
41024	42000	C++ punctuation sequences are not permitted
41025	42000	host variable expression has invalid type
41026	42000	typedef "%s" has invalid
41027	42000	too many 'define' macro (%d)

Error code	SQLSTATE	Message
41028	42000	'%s' macro is already defined at line %d, in file %s
41029	42000	missing host variable
41030	42000	invalid getting groupid variable type: variable "%s" must have signed numeric type
41031	42000	invalid sql statement: getting groupid is available with select/update/delete/insert statement

## A.12 Communication Related Error

- Error code: GOLDILOCKS-specific error code
- SQLSTATE: SQL standard state code
- Message: Error message

**Table A-18** Communication related error

Error code	SQLSTATE	Message
24000	08S01	Communication link failure
24001	08S01	Invalid communication protocol
24002	22000	Invalid GOLDILOCKS_DATA Directory
24003	22000	not supported function
24004	22000	Invalid interprocess protocol
24005	22000	Unable to attach the shared memory segment. unable to access the file '%s'
24006	HV090	Invalid string length or buffer length
24007	22000	not matched command sequence number

**Table A-19** Server communication related error

Error code	SQLSTATE	Message
52000	08S01	Communication link failure
52001	08000	Invalid communication protocol
52002	HY000	Not enough cm unit memory
52003	HY000	exceeded maximum packet allocation timeout
52004	08001	exceeded maximum number of ipc channels
52005	HY000	Timeout expired

## A.13 ServerLibrary Related Error

- Error code: GOLDILOCKS-specific error code
- SQLSTATE: SQL standard state code
- Message: Error message

**Table A-20** ServerLibrary related error

Error code	SQLSTATE	Message
25000	0A000	feature not supported
25001	08001	Server is not running
25002	HY000	Environment Variable "%s" is not defined
25003	08000	Invalid protocol
25004	HY000	STARTUP must be executed in dedicated session
25005	HY000	session killed
25006	HY000	remote session is not opened
25007	42000	the property '%s' of cluster member '%s' is not compatible with the cluster system
25008	42000	the scn '%s' of cluster member '%s' is mismatch
25009	HY000	number of shared servers must be greater than or equal to number of request queues
25010	42000	invalid startup phase
25011	HY000	startup cannot be performed on ipc

## A.14 gsql/ gsqlnet Related Error

- Error code: GOLDILOCKS-specific error code
- SQLSTATE: SQL standard state code
- Message: Error message

**Table A-21** gsql/ gsqlnet related error

Error code	SQLSTATE	Message
40000	42000	syntax error
40001	0A000	feature not supported
40002	HY000	Bind variable "%s" not declared
40003	42000	"%s": table or view does not exist.
40004	42000	"%s": index does not exist.
40005	RD000	Service is not available
40006	RD000	Statement did not prepared
40007	42000	'%s': duplicate statement
40008	42000	'%s': statement does not exist
40009	42000	'%s': statement is not prepared
40010	42000	insufficient privileges
40011	42000	driver does not support %s function
40012	42000	invalid object for describe
40013	42000	driver does not support the requested connection mode( %s )
40014	HY000	the rollback was caused by an unspecified reason
40015	HY000	the rollback was caused by a communication failure
40016	HY000	a deadlock was detected
40017	HY000	a condition that violates the integrity of the resources was detected
40018	HY000	the resource manager rolled back the transaction branch for a reason not on this list
40019	HY000	a protocol error occurred in the resource manager
40020	HY000	a transaction branch took too long
40021	HY000	may retry the transaction branch
40022	HY000	the inclusive upper bound of the rollback codes
40023	HY000	resumption must occur where suspension occurred
40024	HY000	the transaction branch may have been heuristically completed
40025	HY000	the transaction branch has been heuristically committed
40026	HY000	the transaction branch has been heuristically rolled back
40027	HY000	the transaction branch has been heuristically committed and rolled back
40028	HY000	routine returned with no effect and may be re-issued
40029	HY000	the transaction branch was read-only and has been committed
40030	HY000	asynchronous operation already outstanding

Error code	SQLSTATE	Message
40031	HY000	a resource manager error occurred in the transaction branch
40032	HY000	the XID is not valid
40033	HY000	invalid arguments were given
40034	HY000	routine invoked in an improper context
40035	HY000	resource manager unavailable
40036	HY000	the XID already exists
40037	HY000	resource manager doing work outside transaction
40038	HY000	unknown xa error
40039	HY000	marked the transaction branch rollback-only for unspecified reason
40040	HY000	cannot open the resource
40041	HY000	cannot close the resource
40042	HY000	the sql is empty
40043	HY000	invalid host variable type
40044	08003	connection does not exist
40045	HY000	invalid NUMSIZE value: NUMSIZE must be between %d and %d
40046	HY000	invalid PAGESIZE value: PAGESIZE must be between %d and %d
40047	HY000	invalid LINESIZE value: LINESIZE must be between %d and %d
40048	HY000	invalid COLSIZE value: COLSIZE must be between %d and %d
40049	HY000	invalid HISTORY value: HISTORY must be less equal than %d
40050	HY000	invalid DDLSIZE value: DDLSIZE must be between %d and %d
40051	HY000	invalid object identifier
40052	HY000	not enough DDLSIZE. use command: Wset ddlsiz {n}
40053	HY000	confirmation password mismatch
40054	HY000	invalid locator ini property - '%s'
40055	HY000	not exist member '%s' in file - '%s'
40056	HY000	some of nodes were failed to startup
40057	HY000	not specified valid location information
40058	HY000	some of nodes were failed to shutdown
40059	HY000	failed to connect to original driver node '%s' after startup
40060	HY000	cannot execute 'cstartup' or 'cshutdown' command in DA mode
40061	HY000	currently connected node is inactive
40062	HY000	file not exist -'%s'

## A.15 gloader/ gloadernet Related Error

- Error code: GOLDILOCKS-specific error code
- SQLSTATE: SQL standard state code
- Message: Error message

**Table A-22** gloader/ gloadernet related error

Error code	SQLSTATE	Message
42000	RD000	Service is not available
42001	HY000	invalid control file format
42002	HY000	buffer exceeded overflow area
42003	HY000	open same file(%s)
42004	HY000	occur invalid handle error
42005	HY000	occur error while operating SQLGetDiagRec/SQLGetDiagField
42006	HY000	using same character for delimiter and qualifier
42007	HY000	invalid thread unit count.(1~32)
42008	HY000	invalid array size.(1~65535)
42009	HY000	unavailable multithreading in export mode.
42010	08S01	Communication link failure
42011	HY000	invalid file size (minimum size : %d)
42012	HY000	unavailable file size in text mode.
42013	HY000	invalid column type.
42014	HY000	invalid column count.
42015	HY000	invalid data size.
42016	HY000	invalid header of binary file.
42017	HY000	file is empty.
42018	HY000	Qualifier must be 1 length character.
42019	HY000	LF and CR can not be used for delimiter or qualifier.
42020	HY000	qualifiers and terminators must not be subsets of each other
42021	HY000	table name must be given in case of absence of control file.
42022	HY000	can not fetch schema name.
42023	22001	byte length of data greater than column length.
42024	HY000	invalid direct io size

## A.16 gmaster Related Error

- Error code: GOLDILOCKS-specific error code
- SQLSTATE: SQL standard state code
- Message: Error message

**Table A-23** gmaster related error

Error code	SQLSTATE	Message
44000	HY000	database is already mounted
44001	HY000	database is already local opened
44002	HY000	database is already opened
44003	HY000	system thread is already created
44004	HY000	failed to create system threads (%s)
44005	HY000	member '%s' does not exist
44006	HY000	fail to send packet through communication context
44007	HY000	failed to start up a process '%s'



## A.17 glsnr Related Error

- Error code: GOLDILOCKS-specific error code
- SQLSTATE: SQL standard state code
- Message: Error message

**Table A-24** glsnr related error

Error code	SQLSTATE	Message
45000	HY000	Listener configuration file "%s" doesn't exist.
45001	HY000	Environment Variable "%s" is not defined.
45002	HY000	Listener is already started.
45003	HY000	overflow fd
45004	08000	Invalid communication protocol
45005	08004	access denied
45006	HY000	Operation timed out
45007	HY000	shared mode inactive
45008	HY000	Invalid property value [ DEDICATED   SHARED ] : %s
45009	HY000	Invalid property value [ NO   INVITED   EXCLUDED ] : %s
45010	HY000	Invalid property value [ YES   NO   1   0 ]: %s
45011	HY000	Invalid property value [ %ld ~ %ld ]: %s
45012	HY000	Invalid property value [ %ld ~ %ld ]: %s
45013	HY000	buffer over flow %s

## A.18 cyclone Related Error

- Error code: GOLDILOCKS-specific error code
- SQLSTATE: SQL standard state code
- Message: Error message

**Table A-25** cyclone related error

Error code	SQLSTATE	Message
46000	RD000	Service is not available
46001	HY000	"%s": file does not exist
46002	HY000	configure file processing error
46003	HY000	"%s": table does not exist
46004	HY000	"%s": schema does not exist
46005	HY000	"%s.%s": previously Added. Maybe duplicated
46006	HY000	"%s%s": table must have a primary key
46007	HY000	internal error occurred (%s)
46008	HY000	invalid Datatype(%d)
46009	HY000	"%s.%s" table must set supplemental log or primary key.
46010	HY000	group [%s] is already running
46011	HY000	cyclone is not running
46012	HY000	GOLDILOCKS_DATA system environment is invalid
46013	HY000	"%s" log file reused or invalid. restart cyclone with '--reset' option
46014	HY000	fail to analyze flow[%s]
46015	HY000	Invalid Port Number (1024 ~ 49151) [%s]
46016	HY000	Communication link failure
46017	HY000	Invalid Protocol value (%s)
46018	HY000	Master disconnect abnormally
46019	HY000	Protocol Error Occurred (%s)
46020	HY000	Already Slave Connected
46021	HY000	Invalid Transaction Slot Id
46022	HY000	Invalid Supplemental Log (%d)
46023	HY000	Invalid operation for DDL
46024	HY000	Invalid value to analyze
46025	HY000	Invalid group name
46026	HY000	Not set master ip
46027	HY000	Invalid capture information
46028	HY000	There is no group in configure
46029	HY000	Duplicate group name (%s)
46030	HY000	Invalid Value : %s(%ld)
46031	HY000	Too low value : %s(%ld)

Error code	SQLSTATE	Message
46032	HY000	Invalid Host Port(%d)
46033	HY000	Redo Log file Read Timeout (%s)
46034	HY000	Invalid Archive Log File (%s)
46035	HY000	Invalid Temporary File (%s)
46036	HY000	Fail to write file (%s)
46037	HY000	Fail to Update State (%s)
46038	HY000	Fail to set Propagate mode at Session
46039	HY000	There is no active redo log file.
46040	HY000	There is no restart information. Master Database must be started first.
46041	HY000	Can Not Add New Table. Master Database must be started first.(%s.%s)
46042	HY000	Master Database must be started for the first time.
46043	HY000	Invalid Meta File(%s).
46044	HY000	Redo Log File does not exist(%s).
46045	HY000	USER_ID or USER_PW does not exist.
46046	HY000	Slave is not running with --sync option.
46047	HY000	Invalid Connect Information for sync (%s)
46048	HY000	(%s) value is too long
46049	HY000	Invalid encrypt/decrypt key
46050	HY000	no '--key' option
46051	HY000	password already exists (use one of USER_PW or USER_ENCRYPT_PW)
46052	HY000	reset or sync table (%s.%s) has never participated in replication
46053	HY000	reset or sync argument is invalid (%s)
46054	HY000	Table meta file has broken. please restart with '--reset all'
46055	HY000	protocol timeout
46056	HY000	Slave stopped normally
46057	HY000	Cannot use reset and sync option at the same time.
46058	HY000	There is no (%s.%s) table to sync (--sync option)
46059	HY000	(%s.%s) table (%s) column is not acceptable(GENERATED ALWAYS AS IDENTITY)
46060	HY000	driver does not support %s function
46061	HY000	data type is not supported.
46062	HY000	Cluster information does not matched( before groupid(%d), memberid(%d)/current groupid(%d), memberid(%d) )
46063	HY000	Invalid cluster information at configure file( %s )
46064	HY000	Fail to rollback transaction
46065	HY000	Slave is running with --sync option
46066	HY000	MYSQL_DATABASE configuration must needed to connect MySQL/MariaDB

## A.19 LogMirror Related Error

- Error code: GOLDILOCKS-specific error code
- SQLSTATE: SQL standard state code
- Message: Error message

**Table A-26** LogMirror related error

Error code	SQLSTATE	Message
47000	RD000	Service is not available
47001	HY000	Invalid Protocol value (%s)
47002	HY000	"%s": file does not exist
47003	HY000	configure file processing error
47004	HY000	invalid Control file
47005	HY000	Communication link failure
47006	HY000	LogMirror is already running
47007	HY000	GOLDILOCKS_DATA system environment is invalid
47008	HY000	There is no Shared Memory Area for LogMirror
47009	HY000	Invalid Value : %s(%s)
47010	HY000	Invalid port : (%d)
47011	HY000	Master disconnect abnormally
47012	HY000	Invalid Log File(%s)
47013	HY000	Archive Log File does not exist
47014	HY000	Archive Log file Read Timeout (%s)
47015	HY000	LogMirror is not running
47016	HY000	Connection Information does not exist
47017	HY000	Infiniband Receive Fail. (%ld)
47018	HY000	GOLDILOCKS Shutdown or Give-up LogMirror Service.
47019	HY000	Invalid encrypt/decrypt key
47020	HY000	no '--key' option
47021	HY000	password already exists(use one of USER_PW or USER_ENCRYPT_PW)
47022	HY000	protocol heartbeat timeout

## A.20 cymon Related Error

- Error code: GOLDILOCKS-specific error code
- SQLSTATE: SQL standard state code
- Message: Error message

**Table A-27** cymon related error

Error code	SQLSTATE	Message
48000	HY000	GOLDILOCKS_DATA system environment is invalid
48001	HY000	"%s": file does not exist
48002	RD000	Service is not available
48003	HY000	configure file processing error
48004	HY000	Duplicate group name (%s)
48005	HY000	Invalid Value : %s(%ld)
48006	HY000	Invalid group name
48007	HY000	Invalid Port Number (1 ~ 65535)
48008	HY000	There is no group in configure
48009	HY000	cymon is already running
48010	HY000	Communication link failure
48011	HY000	Protocol Error Occurred (%s)
48012	HY000	Already Monitor Connected
48013	HY000	cymon is not running
48014	HY000	internal error occurred (%s)
48015	HY000	Fail to update monitoring info
48016	HY000	USER_ID or USER_PW does not exist.
48017	HY000	Invalid encrypt/decrypt key
48018	HY000	no '--key' option
48019	HY000	password already exists(use one of USER_PW or USER_ENCRYPT_PW)

## A.21 gdispatcher Related Error

- Error code: GOLDILOCKS-specific error code
- SQLSTATE: SQL standard state code
- Message: Error message

**Table A-28** gdispatcher related error

Error code	SQLSTATE	Message
50000	HY000	Dispatcher is already started
50001	HY000	overflow fd

## A.22 gbalancer Related Error

- Error code: GOLDILOCKS-specific error code
- SQLSTATE: SQL standard state code
- Message: Error message

**Table A-29** gbalancer related error

Error code	SQLSTATE	Message
51000	HY000	overflow fd

## A.23 gsyncher Related Error

- Error code: GOLDILOCKS-specific error code
- SQLSTATE: SQL standard state code
- Message: Error message

**Table A-30** gsyncher related error

Error code	SQLSTATE	Message
53000	HY000	invalid phase(%s): executable phase is %s
53001	HY000	GOLDILOCKS_DATA system environment is invalid
53002	HY000	gmaster is active
53003	HY000	gsyncher is already running
53004	HY000	Shared memory is cleared



## A.24 Cluster Related Error

- Error code: GOLDILOCKS-specific error code
- SQLSTATE: SQL standard state code
- Message: Error message

**Table A-31** Cluster related error

Error code	SQLSTATE	Message
56000	HY000	location information of member '%s' already exists
56001	HY000	location information of member '%s' does not exist
56002	HY000	location information of member '%s' is modified by concurrent execution
56003	HY000	has inactive member ( %s )
56004	HY000	location file is corrupted - '%s'
56005	HY000	connections of some cluster members are broken
56006	40000	transaction rollback: failed to prepare global transaction
56007	HY000	must be accessible to at least one of replicas
56008	40000	transaction rollback: failed to synchronize replicas
56009	HY000	remote server ( member ID: %ld ) is abnormally terminated
56010	40000	transaction rollback: remote session is abnormally terminated
56011	HY000	a shared session cannot modify NUMA property
56012	HY000	no connection was established to recover in-doubt transactions
56013	HY000	cannot resolve in-doubt transaction
56014	HY000	MAX_NODE_COUNT property value '%d' must be equal to or less than '%d'
56015	HY000	'%s' property value must be greater than or equal to '%s' property value '%d'
56016	HY000	all members affected by the transaction are inactive - cannot guarantee durability of the transaction
56017	40000	transaction rollback: failed to open remote session
56018	HY000	protocol payload size(%ld) exceed maximum packet size(%ld)
56019	HY000	failover busy
56020	HY000	internal error ( %s, %d )
56021	HY000	exceeded maximum response timeout
56022	HY000	failed to connect to an host
56023	HY000	invalid cluster communication protocol
56024	HY000	sequence '%s' is offline
56025	HY000	cannot synchronize because some members were disconnected
56026	HY000	identity column '%s' of table '%s' is offline
56027	HY000	cannot resolve in-doubt transaction '%d.%d.%ld' because the transaction remains unfinished
56028	HY000	the property '%s' is not compatible with the cluster system
56029	HY000	unable to open a remote session for read only statement

Error code	SQLSTATE	Message
56030	HY000	total cdispatcher threads '%d' must be equal to or less than '%d'
56031	HY000	startup of remote database '%s' is in progress

## A.25 cserver Related Error

- Error code: GOLDILOCKS-specific error code
- SQLSTATE: SQL standard state code
- Message: Error message

**Table A-32** cserver related error

Error code	SQLSTATE	Message
57000	HY000	sample error

## A.26 cdispatcher Related Error

- Error code: GOLDILOCKS-specific error code
- SQLSTATE: SQL standard state code
- Message: Error message

**Table A-33** cdispatcher related error

Error code	SQLSTATE	Message
58000	HY000	the sender failed to connect to the member(%d)
58001	HY000	the socket of target member '%s' is already disconnected
58002	HY000	the location information for member '%s' is not found
58003	HY000	the connection information is invalid; %s %d is either equal to or greater than %d
58004	HY000	the connection timeout from remote(%d)
58005	HY000	the disconnection timeout from remote(%d)
58006	HY000	invalid connection state transition
58007	HY000	dispatcher thread counts of two hosts do not match
58008	HY000	failed to start '%s' thread of cluster dispatcher
58009	HY000	internal error ( %s, %d )
58010	HY000	broken socket
58011	HY000	old cluster connection is still alive
58012	HY000	failover event is in progress
58013	HY000	the connection can be established at LOCAL OPEN or OPEN phase
58014	HY000	old cluster sessions are still alive

## A.27 gtrclogger Related Error

- Error code: GOLDILOCKS-specific error code
- SQLSTATE: SQL standard state code
- Message: Error message

**Table A-34** gtrclogger related error

Error code	SQLSTATE	Message
59000	HY000	exceeded port cnt
59001	HY000	gtrclogger is already running
59002	HY000	gtrclogger is not running
59003	HY000	Operation timed out
59004	22000	Invalid GOLDILOCKS_DATA directory

## A.28 glocator Related Error

- Error code: GOLDILOCKS-specific error code
- SQLSTATE: SQL standard state code
- Message: Error message

**Table A-35** glocator related error

Error code	SQLSTATE	Message
60000	HY000	syntax error
60001	HY000	file does not exist - '%s'
60002	HY000	GOLDILOCKS_DATA system environment is invalid
60003	HY000	Invalid value - %s(%s)
60004	HY000	file name is too long - '%s'
60005	HY000	glocator is already started.
60006	HY000	Location file is corrupted - '%s'
60007	HY000	Property value is out of length - '%s'
60008	HY000	Invalid property value [ YES   NO   1   0 ] - '%s'
60009	HY000	Invalid property value [ %ld ~ %ld ] - '%s'
60010	HY000	Invalid property value [ %ld ~ %ld ] - '%s'
60011	HY000	File is already exist - '%s'
60012	HY000	Location file exceeded max size(%ld) - over size(%ld)
60013	HY000	Not exist node information - '%s'
60014	HY000	Exceeded response time for failover.
60015	HY000	Node is on failover - '%s'
60016	HY000	Need more alternate locator host information.
60017	HY000	Invalid configure file specification - property:[%s]
60018	HY000	Failed to propagate - '%s:%d'
60019	HY000	Not exist service information - '%s'
60020	HY000	'%s' node is already connected.
60021	HY000	overflow fd.

## A.29 gloctl Related Error

- Error code: GOLDILOCKS-specific error code
- SQLSTATE: SQL standard state code
- Message: Error message

**Table A-36** gloctl related error

Error code	SQLSTATE	Message
61000	HY000	Syntax error
61001	HY000	File is not exist - '%s'
61002	HY000	Can not find any ini object in file - '%s'
61003	HY000	Dsn is not exist - '%s'
61004	HY000	ADD MEMBER keyword syntax is error - '%s'
61005	HY000	ADD SERVICE keyword syntax is error - '%s'
61006	HY000	Invalid property value [ YES   NO   1   0 ] - '%s'
61007	HY000	Invalid property value [ %ld ~ %ld ] - '%s'
61008	HY000	Invalid property value [ %ld ~ %ld ] - '%s'
61009	HY000	STL_ENV_DB_DATA system environment is invalid
61010	HY000	Keyword syntax is invalid - '%s'
61011	HY000	Data value is invalid - '%s'

## A.30 gmon Related Error

- Error code: GOLDILOCKS-specific error code
- SQLSTATE: SQL standard state code
- Message: Error message

**Table A-37** gmon related error

Error code	SQLSTATE	Message
62000	HY000	gmon is already running
62001	HY000	process(%ld) did not respond signal
62002	HY000	GOLDILOCKS_DATA system environment is invalid



## A.31 gagent Related Error

- Error code: GOLDILOCKS-specific error code
- SQLSTATE: SQL standard state code
- Message: Error message

**Table A-38** gagent related error

Error code	SQLSTATE	Message
63000	HY000	GOLDILOCKS_DATA system environment is invalid
63001	HY000	Property value is out of length - '%s'
63002	HY000	Invalid property value [ YES   NO   1   0 ] - '%s'
63003	HY000	Invalid property value [ %ld ~ %ld ] - '%s'
63004	HY000	Invalid property value [ %ld ~ %ld ] - '%s'
63005	HY000	gagent is already started.
63006	HY000	file name is too long - '%s'
63007	HY000	file does not exist - '%s'
63008	HY000	Database is not cluster.
63009	HY000	Invalid configure file specification - property:[%s]
63010	HY000	Invalid phase(%s): executable phase is between %s and %s
63011	HY000	Property PORT of dsn(%s) is not set in file 'odbc.ini'
63012	08000	Timeout expired.
63013	HYT00	Unable to establish connection.



## **Appendix B.**

---

### **Wait Event**

## B.1 Wait Event

Performance views which is related to the wait event is as follows.

- v\$system\_event **V\$SYSTEM\_EVENT**
- v\$session\_event **V\$SESSION\_EVENT**
- v\$session\_wait **V\$SESSION\_WAIT**
- v\$wait\_event\_name **V\$WAIT\_EVENT\_NAME**
- v\$wait\_event\_class\_name **V\$WAIT\_EVENT\_CLASS\_NAME**

## B.2 Class of Wait Event

- Administrative: Waits resulting from DBA commands that cause users to wait (for example, an index rebuild)
- Application: Waits resulting from user application code (for example, lock waits caused by row level locking or explicit lock commands)
- Cluster: Waits related to cluster resources (for example, global cache resources )
- Commit: This wait class only comprises one wait event - wait for redo log write confirmation after a commit (that is, 'log file sync')
- Concurrency: Waits for internal database resources (for example, latches)
- Configuration: Waits caused by inadequate configuration of database or instance resources (for example, undersized log file sizes, shared pool size)
- Idle: Waits that signify the session is inactive, waiting for work (for example, 'gsq message from client')
- Network: Waits related to network messaging
- Other: Waits which should not typically occur on a system
- Scheduler: Resource manager related waits
- System IO: Waits for background process IO
- User IO: Waits for user IO

## B.3 Item of Wait Event

### ENQUEUE: GDISPATCHER REQUEST

It is the time of which GDISPATCHER enqueues a request in a shared mode.

Parameter: None

### ENQUEUE: SHARED-SERVER RESPONSE

It is the time of which a shared server enqueues a response in a shared mode.

Parameter: None

### DEQUEUE: SHARED-SERVER REQUEST

It is the time of which a shared server dequeues a request in a shared mode.

Parameter: None

### DEQUEUE: GDISPATCHER RESPONSE

It is the time of which GDISPATCHER dequeues a response in a shared mode.

Parameter: None

### SEND: DEDICATE-SERVER SPOOLED RESPONSE

It is the time of which a dedicate server sends the spooled response to the client in a dedicate mode.

Parameter	Description
send data size	Bytes of the data to be sent

## SEND: DEDICATE-SERVER RESPONSE

It is the time of which a dedicate server sends a response to the client in a dedicate mode.

Parameter	Description
send data size	Bytes of the data to be sent

## RECV: DEDICATE-SERVER REQUEST

It is the time of which a dedicate server receives a request from the client in a dedicate mode.

Parameter: None

## SEND: GDISPATCHER RESPONSE

It is the time of which GDISPATCHER sends a response to a client in a shared mode.

Parameter	Description
send data size	Bytes of the data to be sent

## RECV: GDISPATCHER REQUEST

It is the time of which GDISPATCHER receives a request from a client in a shared mode.

Parameter: None

## ENQUEUE: CLUSTER REQUEST

It is the time of enqueueing a request of cluster.

Parameter: None

## **ENQUEUE: CLUSTER BROADCAST REQUEST**

It is the time of enqueueing a broadcast request of cluster.

Parameter: None

## **DEQUEUE: CLUSTER RESPONSE**

It is the time of dequeuing a response of cluster.

Parameter: None

## **SEND: CDISPATCHER**

It is the time of sending in cluster CDISPATCHER.

Parameter: None

## **RECV: CDISPATCHER**

It is the time of receiving in cluster CDISPATCHER.

Parameter: None

## **GMASTER: ARCHIVE LOG**

It is the time of processing archive logs in gmaster.

Parameter: None

## **GMASTER: CHECKPOINT**

It is the time of processing checkpoints in gmaster.

Parameter: None

## **GMASTER: IO SLAVE**

It is the time of processing IO slave in gmaster.

Parameter: None

## **GMASTER: LOG FLUSH**

It is the time of processing archive logs in gmaster.

Parameter: None

## **GMASTER: PAGE FLUSH**

It is the time of processing page flush in gmaster.

Parameter: None

## **WRITE: TRACE LOG**

It is the time of writing trace logs.

Parameter: None

## **WRITE: COPY ARCHIVING LOG**

It is the time of copying archiving logs.

Parameter: None

## **WRITE: BACKUP CTRL FILE**

It is the time of backing up control files.

Parameter: None



## **WRITE: RESTORE CTRL FILE**

It is the time of restoring the control file.

Parameter: None

## **READ: ARCHIVE LOG**

It is the time of reading archive log files.

Parameter: None

## **READ: CTRL FILE**

It is the time of reading the control file.

Parameter: None

## **WRITE: LOG FILE**

It is the time of writing log files.

Parameter: None

## **WRITE: PAGE FILE**

It is the time of writing page files.

Parameter: None

## **WRITE: CTRL FILE**

It is the time of writing the control file.

Parameter: None

## WRITE: REMOVE DATA FILE

It is the time of removing the data file.

Parameter: None

## WRITE: JOURNAL BUFFER

It is the time of writing journal buffers.

Parameter: None

## READ: JOURNAL BUFFER

It is the time of reading journal buffers.

Parameter: None

## WAIT TRANSACTION

It is the time of waiting for transactions.

Parameter	Description
wait transaction id	Transaction id for which to wait

## WAIT OTHER TRANSACTION

It is the time of waiting for other transactions to be terminated.

Parameter	Description
wait transaction id	ID of the waiting transaction
target transaction id	ID of the transaction to be terminated

## WAIT ENABLE LOGGING

It is the time of waiting until when the logging is available.

Parameter: None

## WAIT LOG FLUSHER

It is the time of waiting for the log flusher.

Parameter	Description
send data size	Bytes of the data to be sent

## WAIT PAGE FLUSHER

It is the time of waiting for the page flusher.

Parameter	Description
send data size	Bytes of the data to be sent

## WAIT XA CONTEXT

It is the time of waiting for the XA context.

Parameter: None

## LATCH: LOG BUFFER

It is the time of waiting for the log buffer latch.

Parameter	Description
address	The address of the latch for which the process is waiting
tries	A count of the number of times the process tried to get the latch

## LATCH: PROCESS MANAGER

It is the time of waiting for the process manager latch.

Parameter	Description
address	The address of the latch for which the process is waiting
tries	A count of the number of times the process tried to get the latch

## LATCH: ENV MGR

It is the time of waiting for the env manager latch.

Parameter	Description
address	The address of the latch for which the process is waiting
tries	A count of the number of times the process tried to get the latch

## LATCH: SESSION ENV MGR

It is the time of waiting for the session env manager latch.

Parameter	Description
address	The address of the latch for which the process is waiting
tries	A count of the number of times the process tried to get the latch

## LATCH: PCH

It is the time of waiting for the Page Control Header (PCH) latch.

Parameter	Description
address	The address of the latch for which the process is waiting
tries	A count of the number of times the process tried to get the latch

## LATCH: PAGE

It is the time of waiting for the page latch.

Parameter	Description
address	The address of the latch for which the process is waiting
tries	A count of the number of times the process tried to get the latch

## LATCH: PENDING LOG

It is the time of waiting for the pending log latch.

Parameter	Description
address	The address of the latch for which the process is waiting
tries	A count of the number of times the process tried to get the latch

## LATCH: ALLOC TRANS

It is the time of waiting for the allocate transaction latch.

Parameter	Description
address	The address of the latch for which the process is waiting
tries	A count of the number of times the process tried to get the latch

## LATCH: UNDO SEGMENT

It is the time of waiting for the undo segment latch.

Parameter	Description
address	The address of the latch for which the process is waiting
tries	A count of the number of times the process tried to get the latch

## LATCH: CLUSTER LOCATION

It is the time of waiting for the cluster location latch.

Parameter	Description
address	The address of the latch for which the process is waiting
tries	A count of the number of times the process tried to get the latch

## LATCH: DICT HASH ELEMENT AGING

It is the time of waiting for the dict hash element aging latch.

Parameter	Description
address	The address of the latch for which the process is waiting
tries	A count of the number of times the process tried to get the latch

## LATCH: DICT HASH RELATED AGING

It is the time of waiting for the dict hash related aging latch.

Parameter	Description
address	The address of the latch for which the process is waiting
tries	A count of the number of times the process tried to get the latch

## LATCH: FILE MANAGER

It is the time of waiting for the file manager latch.

Parameter	Description
address	The address of the latch for which the process is waiting
tries	A count of the number of times the process tried to get the latch

## LATCH: TRACE LOG

It is the time of waiting for the trace log latch.

Parameter	Description
address	The address of the latch for which the process is waiting
tries	A count of the number of times the process tried to get the latch

## LATCH: STATIC HASH

It is the time of waiting for the static hash latch.

Parameter	Description
address	The address of the latch for which the process is waiting
tries	A count of the number of times the process tried to get the latch

## LATCH: STATIC HASH BUCKET

It is the time of waiting for the static hash bucket latch.

Parameter	Description
address	The address of the latch for which the process is waiting
tries	A count of the number of times the process tried to get the latch

## LATCH: SQL HANDLE

It is the time of waiting for SQL handle latch.

Parameter	Description
address	The address of the latch for which the process is waiting
tries	A count of the number of times the process tried to get the latch

## LATCH: XA CONTEXT HASH

It is the time of waiting for XA context hash latch.

Parameter	Description
address	The address of the latch for which the process is waiting
tries	A count of the number of times the process tried to get the latch

## LATCH: PLAN CLOCK

It is the time of waiting for the plan clock latch.

Parameter	Description
address	The address of the latch for which the process is waiting
tries	A count of the number of times the process tried to get the latch

## LATCH: XA CONTEXT

It is the time of waiting for XA context latch.

Parameter	Description
address	The address of the latch for which the process is waiting
tries	A count of the number of times the process tried to get the latch

## LATCH: MEM CONTROLLER

It is the time of waiting for the memory controller latch.

Parameter	Description
address	The address of the latch for which the process is waiting
tries	A count of the number of times the process tried to get the latch



## LATCH: DYNAMIC MEM

It is the time of waiting for the dynamic memory latch.

Parameter	Description
address	The address of the latch for which the process is waiting
tries	A count of the number of times the process tried to get the latch

## LATCH: PROPERTY

It is the time of waiting for the property latch.

Parameter	Description
address	The address of the latch for which the process is waiting
tries	A count of the number of times the process tried to get the latch

## LATCH: ATTACH SHM

It is the time of waiting for the attack shared memory latch.

Parameter	Description
address	The address of the latch for which the process is waiting
tries	A count of the number of times the process tried to get the latch

## LATCH: BACKUP TBS

It is the time of waiting for the backup tablespace latch.

Parameter	Description
address	The address of the latch for which the process is waiting
tries	A count of the number of times the process tried to get the latch

## LATCH: DATABASE COMPONENT

It is the time of waiting for the database component latch.

Parameter	Description
address	The address of the latch for which the process is waiting
tries	A count of the number of times the process tried to get the latch

## LATCH: TABLESPACE

It is the time of waiting for the tablespace latch.

Parameter	Description
address	The address of the latch for which the process is waiting
tries	A count of the number of times the process tried to get the latch

## LATCH: BACKUP DATABASE

It is the time of waiting for the backup database latch.

Parameter	Description
address	The address of the latch for which the process is waiting
tries	A count of the number of times the process tried to get the latch

## LATCH: JOURNAL BUFFER

It is the time of waiting for the journal buffer latch.

Parameter	Description
address	The address of the latch for which the process is waiting
tries	A count of the number of times the process tried to get the latch

## LATCH: JOURNAL BUFFER ENTRY

It is the time of waiting for the journal buffer entry latch.

Parameter	Description
address	The address of the latch for which the process is waiting
tries	A count of the number of times the process tried to get the latch

## LATCH: JOURNAL WRITE BUFFER

It is the time of waiting for the journal write buffer latch.

Parameter	Description
address	The address of the latch for which the process is waiting
tries	A count of the number of times the process tried to get the latch

## LATCH: LOCK ITEM

It is the time of waiting for the lock item latch.

Parameter	Description
address	The address of the latch for which the process is waiting
tries	A count of the number of times the process tried to get the latch

## LATCH: RECORD HASH

It is the time of waiting for the record hash latch.

Parameter	Description
address	The address of the latch for which the process is waiting
tries	A count of the number of times the process tried to get the latch

## LATCH: DEADLOCK

It is the time of waiting for the deadlock latch.

Parameter	Description
address	The address of the latch for which the process is waiting
tries	A count of the number of times the process tried to get the latch

## LATCH: SEQUENCE

It is the time of waiting for the sequence latch.

Parameter	Description
address	The address of the latch for which the process is waiting
tries	A count of the number of times the process tried to get the latch

## LATCH: LOG STREAM

It is the time of waiting for the log stream latch.

Parameter	Description
address	The address of the latch for which the process is waiting
tries	A count of the number of times the process tried to get the latch

## LATCH: BUILD AGABLE SCN

It is the time of waiting for the build agable SCN latch.

Parameter	Description
address	The address of the latch for which the process is waiting
tries	A count of the number of times the process tried to get the latch

## LATCH: TRANSACTION TABLE

It is the time of waiting for the transaction table latch.

Parameter	Description
address	The address of the latch for which the process is waiting
tries	A count of the number of times the process tried to get the latch

## LATCH: SESSION LINK HASH

It is the time of waiting for the session link hash latch.

Parameter	Description
address	The address of the latch for which the process is waiting
tries	A count of the number of times the process tried to get the latch

## LATCH: ALLOC XA CONTEXT

It is the time of waiting for the allocate XA context latch.

Parameter	Description
address	The address of the latch for which the process is waiting
tries	A count of the number of times the process tried to get the latch

## LATCH: SEQUENCE GLOBALX

It is the time of waiting for the sequence global latch X.

Parameter	Description
address	The address of the latch for which the process is waiting
tries	A count of the number of times the process tried to get the latch

## LATCH: SEQUENCE GLOBALY

It is the time of waiting for the sequence global latch Y.

Parameter	Description
address	The address of the latch for which the process is waiting
tries	A count of the number of times the process tried to get the latch

## LATCH: TRANSACTION LOG FILE

It is the time of waiting for the transaction logfile latch.

Parameter	Description
address	The address of the latch for which the process is waiting
tries	A count of the number of times the process tried to get the latch

## **Appendix C.**

---

### **Open Source License**

## Apache License, Version 2.0

Apache License

Version 2.0, January 2004

<http://www.apache.org/licenses/>

### TERMS AND CONDITIONS FOR USE, REPRODUCTION, AND DISTRIBUTION

#### 1. Definitions.

"License" shall mean the terms and conditions for use, reproduction, and distribution as defined by Sections 1 through 9 of this document.

"Licensor" shall mean the copyright owner or entity authorized by the copyright owner that is granting the License.

"Legal Entity" shall mean the union of the acting entity and all other entities that control, are controlled by, or are under common control with that entity. For the purposes of this definition, "control" means (i) the power, direct or indirect, to cause the direction or management of such entity, whether by contract or otherwise, or (ii) ownership of fifty percent (50%) or more of the outstanding shares, or (iii) beneficial ownership of such entity.

"You" (or "Your") shall mean an individual or Legal Entity exercising permissions granted by this License.

"Source" form shall mean the preferred form for making modifications, including but not limited to software source code, documentation source, and configuration files.

"Object" form shall mean any form resulting from mechanical transformation or translation of a Source form, including but not limited to compiled object code, generated documentation, and conversions to other media types.

"Work" shall mean the work of authorship, whether in Source or Object form, made available under the License, as indicated by a copyright notice that is included in or attached to the work (an example is provided in the Appendix below).

"Derivative Works" shall mean any work, whether in Source or Object form, that is based on (or derived from) the Work and for which the editorial revisions, annotations, elaborations, or other modifications represent, as a whole, an original work of authorship. For the purposes of this License, Derivative Works shall not include works that remain separable from, or merely link (or bind by name) to the interfaces of, the Work and Derivative Works thereof.

"Contribution" shall mean any work of authorship, including the original version of the Work and any modifications or additions to that Work or Derivative Works thereof, that is intentionally submitted to Licensor or for inclusion in the Work by the copyright owner or by an individual or Legal Entity authorized to submit it on behalf of the copyright owner. For the purposes of this definition, "submitted" means any form of electronic, verbal, or written communication sent to the Licensor or its representatives, including but not li



mitted to communication on electronic mailing lists, source code control systems, and issue tracking systems that are managed by, or on behalf of, the Licensor for the purpose of discussing and improving the Work, but excluding communication that is conspicuously marked or otherwise designated in writing by the copyright owner as "Not a Contribution."

"Contributor" shall mean Licensor and any individual or Legal Entity on behalf of whom a Contribution has been received by Licensor and subsequently incorporated within the Work.

## **2. Grant of Copyright License.**

Subject to the terms and conditions of this License, each Contributor hereby grants to You a perpetual, worldwide, non-exclusive, no-charge, royalty-free, irrevocable copyright license to reproduce, prepare Derivative Works of, publicly display, publicly perform, sublicense, and distribute the Work and such Derivative Works in Source or Object form.

## **3. Grant of Patent License.**

Subject to the terms and conditions of this License, each Contributor hereby grants to You a perpetual, worldwide, non-exclusive, no-charge, royalty-free, irrevocable (except as stated in this section) patent license to make, have made, use, offer to sell, sell, import, and otherwise transfer the Work, where such license applies only to those patent claims licensable by such Contributor that are necessarily infringed by their Contribution(s) alone or by combination of their Contribution(s) with the Work to which such Contribution(s) was submitted. If You institute patent litigation against any entity (including a cross-claim or counter claim in a lawsuit) alleging that the Work or a Contribution incorporated within the Work constitutes direct or contributory patent infringement, then any patent licenses granted to You under this License for that Work shall terminate as of the date such litigation is filed.

## **4. Redistribution.**

You may reproduce and distribute copies of the Work or Derivative Works thereof in any medium, with or without modifications, and in Source or Object form, provided that You meet the following conditions:

1. You must give any other recipients of the Work or Derivative Works a copy of this License; and
2. You must cause any modified files to carry prominent notices stating that You changed the files; and
3. You must retain, in the Source form of any Derivative Works that You distribute, all copyright, patent, trademark, and attribution notices from the Source form of the Work, excluding those notices that do not pertain to any part of the Derivative Works; and
4. If the Work includes a "NOTICE" text file as part of its distribution, then any Derivative Works that You distribute must include a readable copy of the attribution notices contained within such NOTICE file, excluding those notices that do not pertain to any part of the Derivative Works, in at least one of the following places: within a NOTICE text file distributed as part of the Derivative Works; within the Source form or documentation, if provided along with the Derivative Works; or, within a display gen

erated by the Derivative Works, if and wherever such third-party notices normally appear. The contents of the NOTICE file are for informational purposes only and do not modify the License. You may add Your own attribution notices within Derivative Works that You distribute, alongside or as an addendum to the NOTICE text from the Work, provided that such additional attribution notices cannot be construed as modifying the License.

You may add Your own copyright statement to Your modifications and may provide additional or different license terms and conditions for use, reproduction, or distribution of Your modifications, or for any such Derivative Works as a whole, provided Your use, reproduction, and distribution of the Work otherwise complies with the conditions stated in this License.

## **5. Submission of Contributions.**

Unless You explicitly state otherwise, any Contribution intentionally submitted for inclusion in the Work by You to the Licensor shall be under the terms and conditions of this License, without any additional terms or conditions. Notwithstanding the above, nothing herein shall supersede or modify the terms of any separate license agreement you may have executed with Licensor regarding such Contributions.

## **6. Trademarks.**

This License does not grant permission to use the trade names, trademarks, service marks, or product names of the Licensor, except as required for reasonable and customary use in describing the origin of the Work and reproducing the content of the NOTICE file.

## **7. Disclaimer of Warranty.**

Unless required by applicable law or agreed to in writing, Licensor provides the Work (and each Contributor or provides its Contributions) on an "AS IS" BASIS, WITHOUT WARRANTIES OR CONDITIONS OF ANY KIND, either express or implied, including, without limitation, any warranties or conditions of TITLE, NON-INFRINGEMENT, MERCHANTABILITY, or FITNESS FOR A PARTICULAR PURPOSE. You are solely responsible for determining the appropriateness of using or redistributing the Work and assume any risks associated with Your exercise of permissions under this License.

## **8. Limitation of Liability.**

In no event and under no legal theory, whether in tort (including negligence), contract, or otherwise, unless required by applicable law (such as deliberate and grossly negligent acts) or agreed to in writing, shall any Contributor be liable to You for damages, including any direct, indirect, special, incidental, or consequential damages of any character arising as a result of this License or out of the use or inability to use the Work (including but not limited to damages for loss of goodwill, work stoppage, computer failure or malfunction, or any and all other commercial damages or losses), even if such Contributor has been advised of the possibility of such damages.

## 9. Accepting Warranty or Additional Liability.

While redistributing the Work or Derivative Works thereof, You may choose to offer, and charge a fee for, acceptance of support, warranty, indemnity, or other liability obligations and/or rights consistent with this License. However, in accepting such obligations, You may act only on Your own behalf and on Your sole responsibility, not on behalf of any other Contributor, and only if You agree to indemnify, defend, and hold each Contributor harmless for any liability incurred by, or claims asserted against, such Contributor by reason of your accepting any such warranty or additional liability.

Copyright 2019-2022 SUNJESoft Inc.

Licensed under the Apache License, Version 2.0 (the "License");

you may not use this file except in compliance with the License. You may obtain a copy of the License at <http://www.apache.org/licenses/LICENSE-2.0>

Unless required by applicable law or agreed to in writing, software distributed under the License is distributed on an "AS IS" BASIS, WITHOUT WARRANTIES OR CONDITIONS OF ANY KIND, either express or implied. See the License for the specific language governing permissions and limitations under the License.

